

Sensorless Motor Control IC for Appliances

Features

- **MCE™ (Motion Control Engine) - Hardware based computation engine for high efficiency sinusoidal sensorless control of permanent magnet AC motor**
- **Supports both interior and surface permanent magnet motors**
- **Built-in hardware peripheral for single shunt current feedback reconstruction**
- **No external current or voltage sensing operational amplifier required**
- **Three/two-phase Space Vector PWM**
- **Three-channel analog output (PWM)**
- **Embedded 8-bit high speed microcontroller (8051) for flexible I/O and man-machine control**
- **JTAG programming port for emulation/debugger**
- **Serial communication interface (UART)**
- **I²C/SPI serial interface**
- **Watchdog timer with independent analog clock**
- **Three general purpose timers/counters**
- **Two special timers: periodic timer, capture timer**
- **External EEPROM and internal RAM facilitate debugging and code development**
- **Pin compatible with IRMCK341, OTP-ROM version**
- **1.8V/3.3V CMOS**

Product Summary

| | |
|---|-----------------|
| Maximum crystal frequency | 60 MHz |
| Maximum internal clock (SYSCLK) frequency | 128 MHz |
| Sensorless control computation time | 11 µsec typ |
| MCE™ computation data range | 16 bit signed |
| Program RAM loaded from external EEPROM | 48K bytes |
| Data RAM | 8K bytes |
| GateKill latency (digital filtered) | 2 µsec |
| PWM carrier frequency counter | 16 bits/ SYSCLK |
| A/D input channels | 8 |
| A/D converter resolution | 12 bits |
| A/D converter conversion speed | 2 µsec |
| 8051 instruction execution speed | 2 SYSCLK |
| Analog output (PWM) resolution | 8 bits |
| UART baud rate (typ) | 57.6K bps |
| Number of I/O (max) | 24 |
| Package (lead-free) | QFP64 |

Description

IRMCF341 is a high performance RAM based motion control IC designed primarily for appliance applications. IRMCF341 is designed to achieve low cost and high performance control solutions for advanced inverterized appliance motor control. IRMCF341 contains two computation engines. One is Motion Control Engine (MCE™) for sensorless control of permanent magnet motors; the other is an 8-bit high-speed microcontroller (8051). Both computation engines are integrated into one monolithic chip. The MCE™ contains a collection of control elements such as Proportional plus Integral, Vector rotator, Angle estimator, Multiply/Divide, Low loss SVPWM, Single Shunt IFB. The user can program a motion control algorithm by connecting these control elements using a graphic compiler. Key components of the sensorless control algorithms, such as the Angle Estimator, are provided as complete pre-defined control blocks implemented in hardware. A unique analog/digital circuit and algorithm to fully support single shunt current reconstruction is also provided. The 8051 microcontroller performs 2-cycle instruction execution (60MIPS at 120MHz). The MCE and 8051 microcontroller are connected via dual port RAM to process signal monitoring and command input. An advanced graphic compiler for the MCE™ is seamlessly integrated into the MATLAB/Simulink environment, while third party JTAG based emulator tools are supported for 8051 developments. IRMCF341 comes with a small QFP64 pin lead-free package.

TABLE OF CONTENTS

| | | |
|-------|--|----|
| 1 | Overview | 4 |
| 2 | IRMCF341 Block Diagram and Main Functions | 5 |
| 3 | Pinout | 7 |
| 4 | Input/Output of IRMCF341 | 8 |
| 4.1 | 8051 Peripheral Interface Group | 8 |
| 4.2 | Motion Peripheral Interface Group | 10 |
| 4.3 | Analog Interface Group | 10 |
| 4.4 | Power Interface Group | 11 |
| 4.5 | Test Interface Group | 11 |
| 5 | Application Connections | 12 |
| 6 | DC Characteristics | 13 |
| 6.1 | Absolute Maximum Ratings | 13 |
| 6.2 | System Clock Frequency and Power Consumption | 13 |
| 6.3 | Digital I/O DC Characteristics | 14 |
| 6.4 | PLL and Oscillator DC characteristics | 15 |
| 6.5 | Analog I/O DC Characteristics | 15 |
| 6.6 | Under Voltage Lockout DC characteristics | 16 |
| 6.7 | CMEXT and AREF Characteristics | 16 |
| 7 | AC Characteristics | 17 |
| 7.1 | PLL AC Characteristics | 17 |
| 7.2 | Analog to Digital Converter AC Characteristics | 18 |
| 7.3 | Op amp AC Characteristics | 19 |
| 7.4 | SYNC to SVPWM and A/D Conversion AC Timing | 20 |
| 7.5 | GATEKILL to SVPWM AC Timing | 21 |
| 7.6 | Interrupt AC Timing | 21 |
| 7.7 | I ² C AC Timing | 22 |
| 7.8 | SPI AC Timing | 23 |
| 7.8.1 | SPI Write AC timing | 23 |
| 7.8.2 | SPI Read AC Timing | 24 |
| 7.9 | UART AC Timing | 25 |
| 7.10 | CAPTURE Input AC Timing | 26 |
| 7.11 | JTAG AC Timing | 27 |
| 8 | Pin List | 28 |
| 9 | Package Dimensions | 31 |
| 10 | Part Marking Information | 32 |

TABLE OF FIGURES

| | |
|--|----|
| Figure 1. Typical Application Block Diagram Using IRMCF341 | 4 |
| Figure 2. IRMCF341 Internal Block Diagram | 5 |
| Figure 3. IRMCF341 Pin Configuration | 7 |
| Figure 4. Input/Output of IRMCF341 | 8 |
| Figure 5. Application Connection of IRMCF341 | 12 |
| Figure 6. Clock Frequency vs. Power Consumption | 13 |

TABLE OF TABLES

| | |
|---|----|
| Table 1. Absolute Maximum Ratings | 13 |
| Table 2. System Clock Frequency | 13 |
| Table 3. Digital I/O DC Characteristics | 14 |
| Table 4. PLL DC Characteristics | 15 |
| Table 5. Analog I/O DC Characteristics | 15 |
| Table 6. UVcc DC Characteristics | 16 |
| Table 7. CMEXT and AREF DC Characteristics | 16 |
| Table 8. PLL AC Characteristics | 17 |
| Table 9. A/D Converter AC Characteristics | 18 |
| Table 10. Current Sensing OP Amp AC Characteristics | 19 |
| Table 11. SYNC AC Characteristics | 20 |
| Table 12. GATEKILL to SVPWM AC Timing | 21 |
| Table 13. Interrupt AC Timing | 21 |
| Table 14. I ² C AC Timing | 22 |
| Table 15. SPI Write AC Timing | 23 |
| Table 16. SPI Read AC Timing | 24 |
| Table 17. UART AC Timing | 25 |
| Table 18. CAPTURE AC Timing | 26 |
| Table 19. JTAG AC Timing | 27 |
| Table 20. Pin List | 30 |

1 Overview

IRMCF341 is a new International Rectifier integrated circuit device primarily designed as a one-chip solution for complete inverter controlled appliance motor control applications. Unlike a traditional microcontroller or DSP, the IRMCF341 provides a built-in closed loop sensorless control algorithm using the unique Motion Control Engine (MCE™) for permanent magnet motors. The MCE™ consists of a collection of control elements, motion peripherals, a dedicated motion control sequencer and dual port RAM to map internal signal nodes. IRMCF341 also employs a unique single shunt current reconstruction circuit to eliminate additional analog/digital circuitry and enables a direct shunt resistor interface to the IC. Motion control programming is achieved using a dedicated graphical compiler integrated into the MATLAB/Simulink™ development environment. Sequencing, user interface, host communication, and upper layer control tasks can be implemented in the 8051 high-speed 8-bit microcontroller. The 8051 microcontroller is equipped with a JTAG port to facilitate emulation and debugging tools. Figure 1 shows a typical application schematic using the IRMCF341.

IRMCF341 is intended for development purpose and contains 48K bytes of RAM, which can be loaded from external EEPROM for 8051 program execution. For high volume production, IRMCK341 contains OTP ROM in place of program RAM to reduce the cost. Both IRMCF341 and IRMCK341 come in the same 64-pin QFP package with identical pin configuration to facilitate PC board layout and transition to mass production

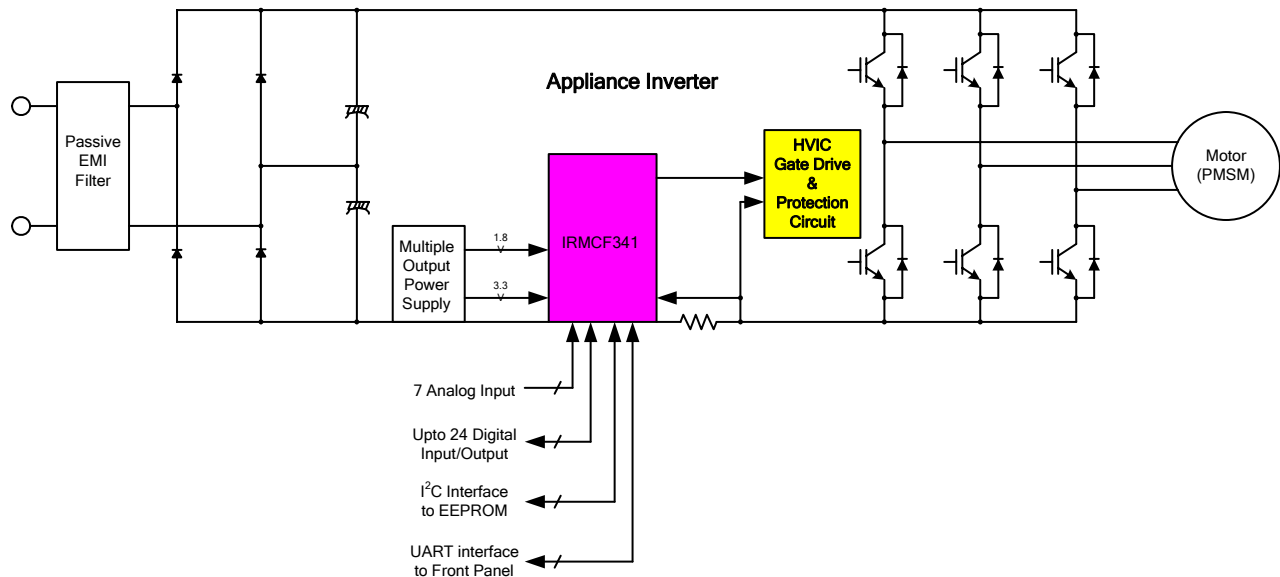

Figure 1. Typical Application Block Diagram Using IRMCF341

2 IRMCF341 Block Diagram and Main Functions

IRMCF341 block diagram is shown in Figure 2.

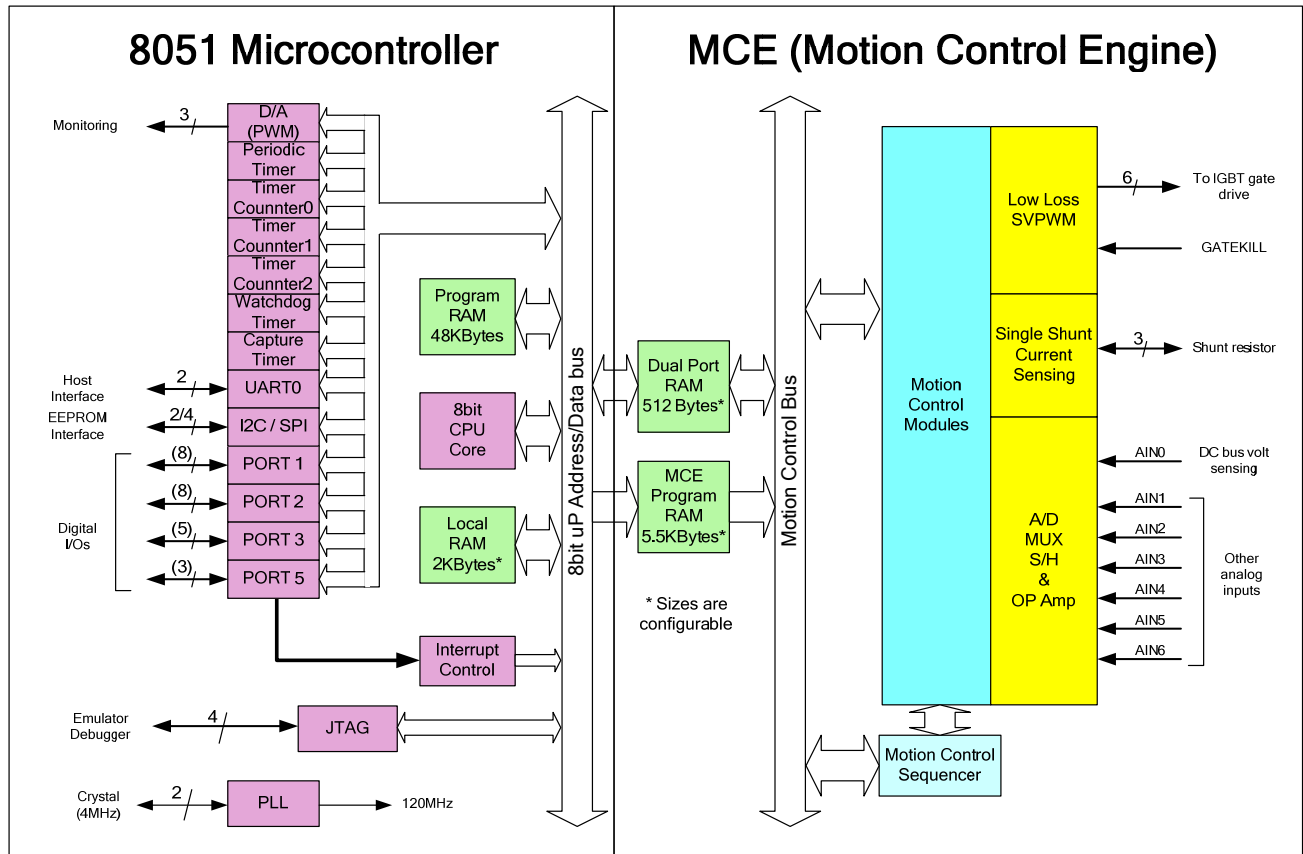

Figure 2. IRMCF341 Internal Block Diagram

IRMCF341 contains the following functions for sensorless AC motor control applications:

- Motion Control Engine (MCE™)
 - Proportional plus Integral block
 - Low pass filter
 - Differentiator and lag (high pass filter)
 - Ramp
 - Limit
 - Angle estimate (sensorless control)
 - Inverse Clark transformation
 - Vector rotator
 - Bit latch
 - Peak detect

- Transition
 - Multiply-divide (signed and unsigned)
 - Divide (signed and unsigned)
 - Adder
 - Subtractor
 - Comparator
 - Counter
 - Accumulator
 - Switch
 - Shift
 - ATAN (arc tangent)
 - Function block (any curve fitting, nonlinear function)
 - 16-bit wide Logic operations (AND, OR, XOR, NOT, NEGATE)
 - MCE™ program and data memory (6K byte). ^{Note 1}
 - MCE™ control sequencer
- 8051 microcontroller
 - Three 16-bit timer/counters
 - 16-bit periodic timer
 - 16-bit analog watchdog timer
 - 16-bit capture timer
 - Up to 24 discrete I/Os
 - Eight-channel 12-bit A/D
 - One buffered channel for current sensing (0 – 1.2V input)
 - Seven unbuffered channels (0 – 1.2V input)
 - JTAG port (4 pins)
 - Up to three channels of analog output (8-bit PWM)
 - UART
 - I²C/SPI port
 - 48K byte program RAM loaded from external EEPROM
 - 2K byte data RAM. ^{Note 1}

Note 1: Total size of RAM is 8K byte including MCE program, MCE data, and 8051 data. Different sizes can be allocated depending on applications.

3 Pinout

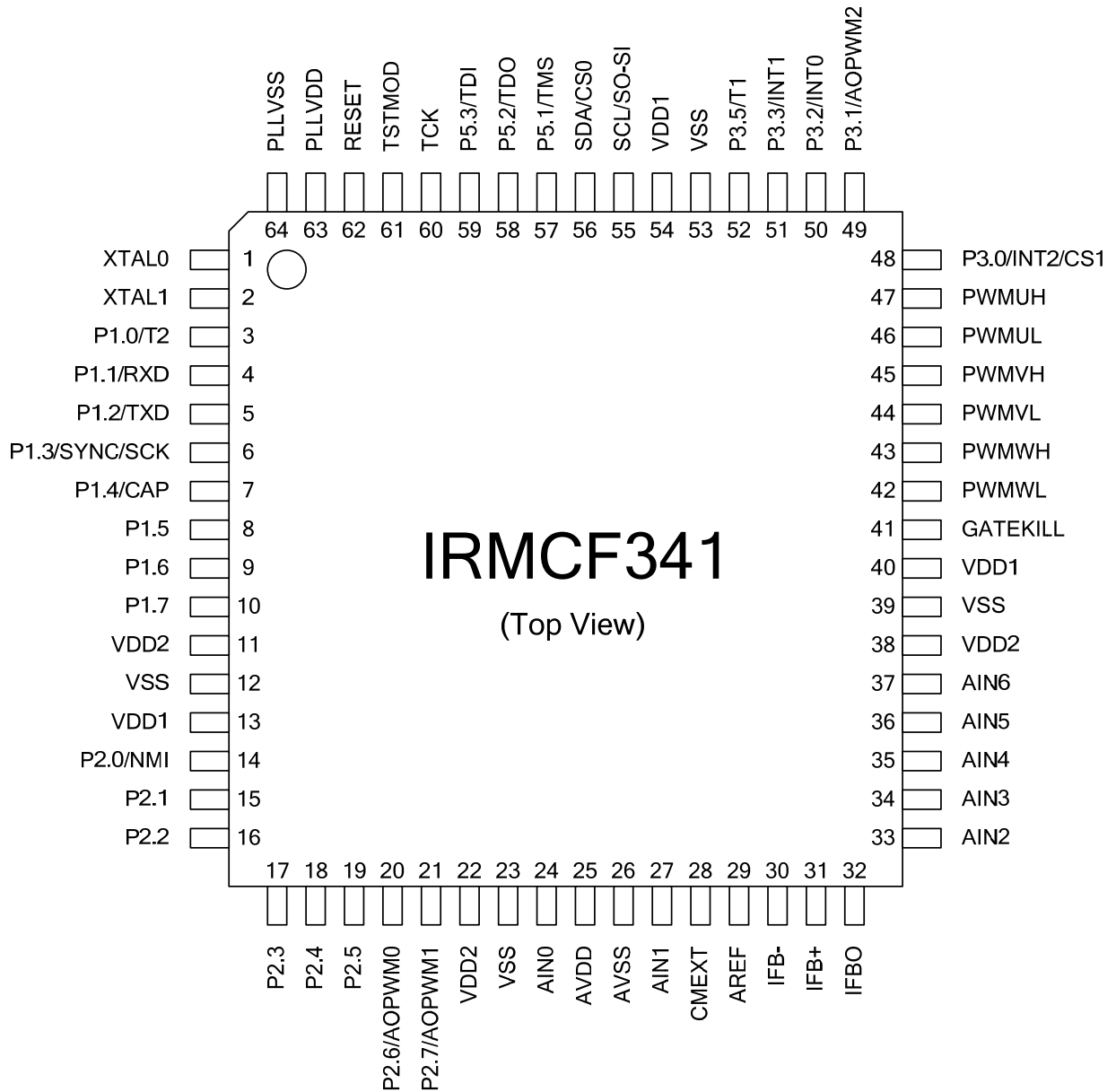

Figure 3. IRMCF341 Pin Configuration

4 Input/Output of IRMCF341

All I/O signals of IRMCF341 are shown in Figure 4. All I/O pins are 3.3V logic interface except A/D interface pins.

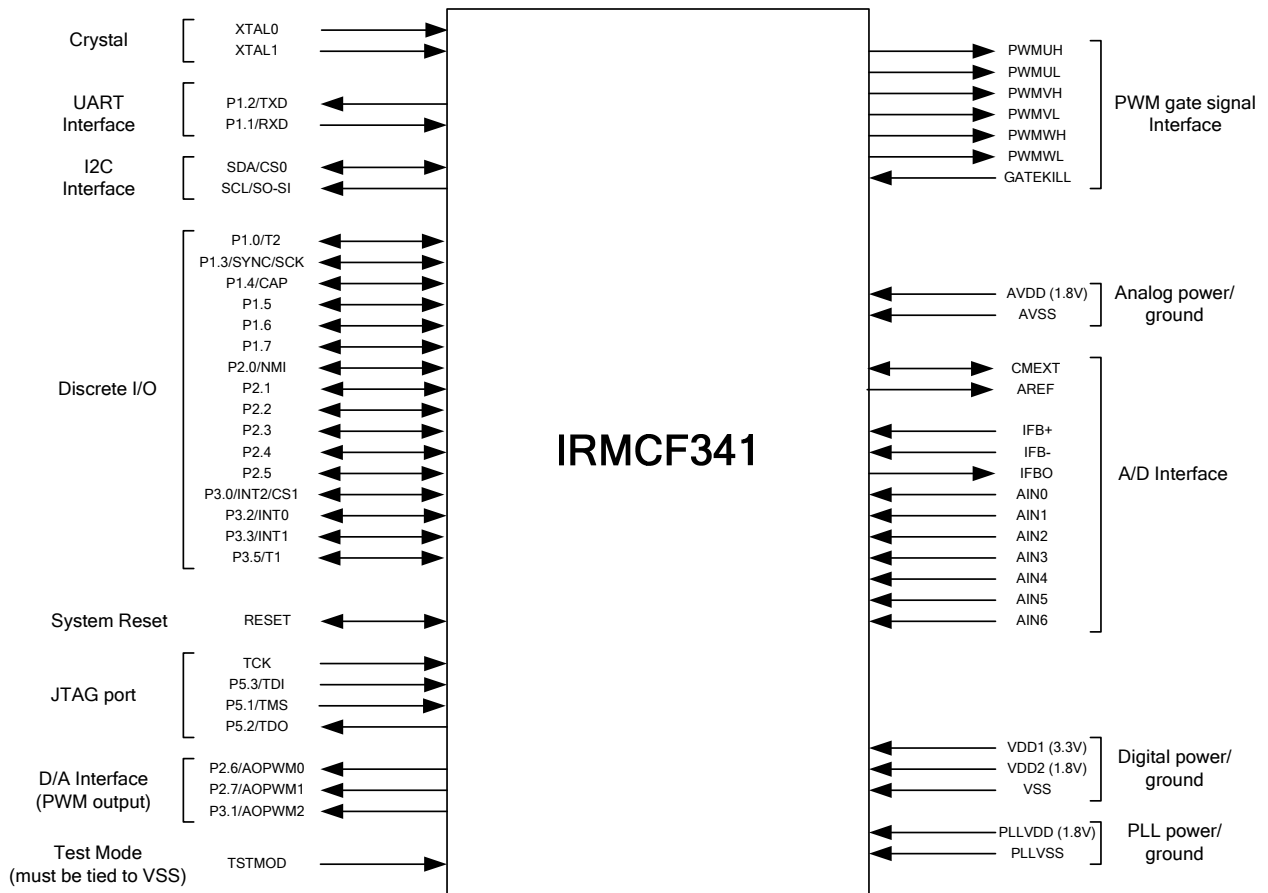

Figure 4. Input/Output of IRMCF341

4.1 8051 Peripheral Interface Group

UART Interface

TXD Output, Transmit data from IRMCF341
RXD Input, Receive data to IRMCF341

Discrete I/O Interface

P1.0/T2 Input/output port 1.0, can be configured as Timer/Counter 2 input
P1.1/RXD Input/output port 1.1, can be configured as RXD input
P1.2/TXD Input/output port 1.2, can be configured as TXD output

| | |
|---------------|--|
| P1.3/SYNC/SCK | Input/output port 1.3, can be configured as SYNC output or SPI clock output, needs to be pulled up to VDD1 in order to boot from I ² C EEPROM |
| P1.4/CAP | Input/output port 1.4, can be configured as Capture Timer input |
| P1.5 | Input/output port 1.5 |
| P1.6 | Input/output port 1.6 |
| P1.7 | Input/output port 1.7 |
| P2.0/NMI | Input/output port 2.0, can be configured as non-maskable interrupt input |
| P2.1 | Input/output port 2.1 |
| P2.2 | Input/output port 2.2 |
| P2.3 | Input/output port 2.3 |
| P2.4 | Input/output port 2.4 |
| P2.5 | Input/output port 2.5 |
| P2.6/AOPWM0 | Input/output port 2.6, can be configured as AOPWM0 output |
| P2.7/AOPWM1 | Input/output port 2.7, can be configured as AOPWM1 output |
| P3.0/INT2/CS1 | Input/output port 3.0, can be configured as INT2 input or SPI chip select 1 |
| P3.1/AOPWM2 | Input/output port 3.1, can be configured as AOPWM2 output |
| P3.2/NINT0 | Input/output port 3.2, can be configured as INT0 input |
| P3.3/NINT1 | Input/output port 3.3, can be configured as INT1 input |
| P3.5/T1 | Input/output port 3.5, can be configured as Timer/Counter 1 input |
| P5.1/TSM | Input/output port 5.1, configured as JTAG port by default |
| P5.2/TDO | Input/output port 5.2, configured as JTAG port by default |
| P5.3/TDI | Input/output port 5.3, configured as JTAG port by default |

Analog Output Interface

| | |
|-------------|---|
| P2.6/AOPWM0 | Input/output, can be configured as 8-bit PWM output 0 with programmable carrier frequency |
| P2.7/AOPWM1 | Input/output, can be configured as 8-bit PWM output 1 with programmable carrier frequency |
| P3.1/AOPWM2 | Input/output, can be configured as 8-bit PWM output 2 with programmable carrier frequency |

Crystal Interface

| | |
|-------|------------------------------|
| XTAL0 | Input, connected to crystal |
| XTAL1 | Output, connected to crystal |

Reset Interface

| | |
|-------|--|
| RESET | Inout, system reset, needs to be pulled up to VDD1 but doesn't require external RC time constant |
|-------|--|

I²C Interface

| | |
|-----------|---|
| SCL/SO-SI | Output, I ² C clock output, or SPI data |
| SDA/CS0 | Input/output, I ² C Data line or SPI chip select 0 |

I²C/SPI Interface

| | |
|-----------|---|
| SCL/SO-SI | Output, I ² C clock output, or SPI data |
| SDA/CS0 | Input/output, I ² C data line or SPI chip select 0 |

| | |
|---------------|--|
| P1.3/SYNC/SCK | Input/output port 1.3, can be configured as SYNC output or SPI clock output, needs to be pulled up to VDD1 in order to boot from I ² C EEPROM |
| P3.0/INT2/CS1 | Input/output port 3.0, can be configured as INT2 input or SPI chip select 1 |

4.2 Motion Peripheral Interface Group

PWM

| | |
|-------|---|
| PWMUH | Output, PWM phase U high side gate signal |
| PWMUL | Output, PWM phase U low side gate signal |
| PWMVH | Output, PWM phase V high side gate signal |
| PWMVL | Output, PWM phase V low side gate signal |
| PWMWH | Output, PWM phase W high side gate signal |
| PWMWL | Output, PWM phase W low side gate signal |

Fault

| | |
|----------|---|
| GATEKILL | Input, upon assertion, this negates all six PWM signals, programmable logic sense |
|----------|---|

4.3 Analog Interface Group

| | |
|-------|---|
| AVDD | Analog power (1.8V) |
| AVSS | Analog power return |
| AREF | 0.6V buffered output |
| CMEXT | Unbuffered 0.6V, input to the AREF buffer, capacitor needs to be connected. |
| IFB+ | Input, Operational amplifier positive input for shunt resistor current sensing |
| IFB- | Input, Operational amplifier negative input for shunt resistor current sensing |
| IFBO | Output, Operational amplifier output for shunt resistor current sensing |
| AIN0 | Input, Analog input channel 0 (0 – 1.2V), typically configured for DC bus voltage input |
| AIN1 | Input, Analog input channel 1 (0 – 1.2V), needs to be pulled down to AVSS if unused |
| AIN2 | Input, Analog input channel 2 (0 – 1.2V), needs to be pulled down to AVSS if unused |
| AIN3 | Input, Analog input channel 3 (0 – 1.2V), needs to be pulled down to AVSS if unused |
| AIN4 | Input, Analog input channel 4 (0 – 1.2V), needs to be pulled down to AVSS if unused |
| AIN5 | Input, Analog input channel 5 (0 – 1.2V), needs to be pulled down to AVSS if unused |
| AIN6 | Input, Analog input channel 6 (0 – 1.2V), needs to be pulled down to AVSS if unused |

4.4 Power Interface Group

| | |
|--------|-------------------------------------|
| VDD1 | Digital power for I/O (3.3V) |
| VDD2 | Digital power for core logic (1.8V) |
| VSS | Digital common |
| PLLVD | PLL power (1.8V) |
| PLLVSS | PLL ground return |

4.5 Test Interface Group

| | |
|----------|---|
| TSTMOD | Must be tied to VSS, used only for factory testing. |
| P5.1/TSM | Input/output port 5.1, configured as JTAG port by default |
| P5.2/TDO | Input/output port 5.2, configured as JTAG port by default |
| P5.3/TDI | Input/output port 5.3, configured as JTAG port by default |
| TCK | Input, JTAG test clock |

5 Application Connections

Typical application connection is shown in Figure 5. All components necessary to implement a complete sensorless drive control algorithm are shown connected to IRMCF341.

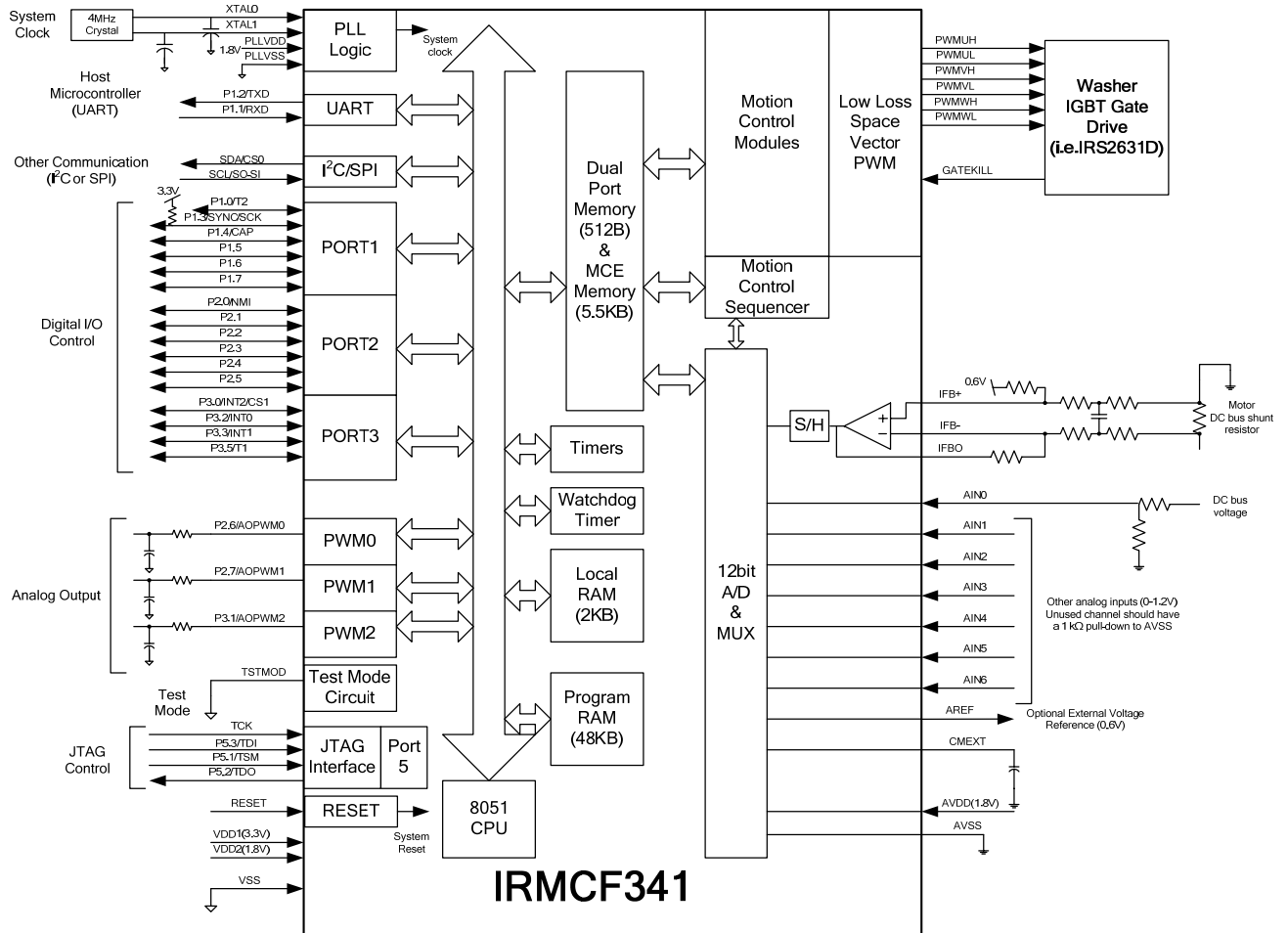

Figure 5. Application Connection of IRMCF341

6 DC Characteristics

6.1 Absolute Maximum Ratings

| Symbol | Parameter | Min | Typ | Max | Condition |
|------------------|-----------------------|--------|-----|--------|-----------------|
| V _{DD1} | Supply Voltage | -0.3 V | - | 3.6 V | Respect to VSS |
| V _{DD2} | Supply Voltage | -0.3 V | - | 1.98 V | Respect to VSS |
| V _{IA} | Analog Input Voltage | -0.3 V | - | 1.98 V | Respect to AVSS |
| V _{ID} | Digital Input Voltage | -0.3 V | - | 3.65 V | Respect to VSS |
| T _A | Ambient Temperature | -40 °C | - | 85 °C | |
| T _S | Storage Temperature | -65 °C | - | 150 °C | |

Table 1. Absolute Maximum Ratings

Caution: Stresses beyond those listed in “Absolute Maximum Ratings” may cause permanent damage to the device. These are stress ratings only and function of the device at these or any other conditions beyond those indicated in the operational sections of the specifications are not implied.

6.2 System Clock Frequency and Power Consumption

| Symbol | Parameter | Min | Typ | Max | Unit |
|--------|--------------|-----|-----|-----|------|
| SYSCLK | System Clock | 32 | - | 128 | MHz |

Table 2. System Clock Frequency

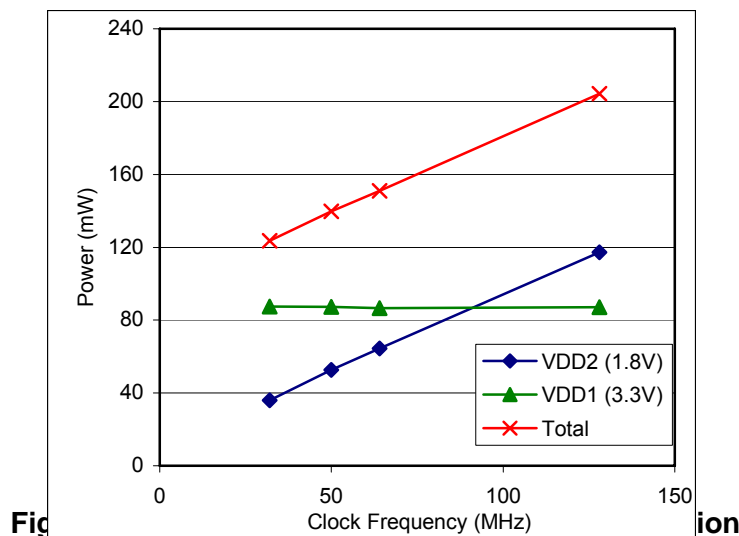

6.3 Digital I/O DC Characteristics

| Symbol | Parameter | Min | Typ | Max | Condition |
|---------------------------------|---------------------------|---------|---------|---------|--------------------------------|
| V _{DD1} | Supply Voltage | 3.0 V | 3.3 V | 3.6 V | Recommended |
| V _{DD2} | Supply Voltage | 1.62 V | 1.8 V | 1.98 V | Recommended |
| V _{IL} | Input Low Voltage | -0.3 V | - | 0.8 V | Recommended |
| V _{IH} | Input High Voltage | 2.0 V | | 3.6 V | Recommended |
| C _{IN} | Input capacitance | - | 3.6 pF | - | (1) |
| I _L | Input leakage current | | ±10 nA | ±1 µA | V _O = 3.3 V or 0 V |
| I _{OL1} ⁽²⁾ | Low level output current | 8.9 mA | 13.2 mA | 15.2 mA | V _{OL} = 0.4 V (1) |
| I _{OH1} ⁽²⁾ | High level output current | 12.4 mA | 24.8 mA | 38 mA | V _{OH} = 2.4 V (1) |
| I _{OL2} ⁽³⁾ | Low level output current | 17.9 mA | 26.3 mA | 33.4 mA | V _{OL} = 0.4 V (1) |
| I _{OH2} ⁽³⁾ | High level output current | 24.6 mA | 49.5 mA | 81 mA | V _{OH} = 2.4 V (1) |

Table 3. Digital I/O DC Characteristics

Note:

- (1) Data guaranteed by design.
- (2) Applied to SCL/SO-SI, SDA/CS0 pins.
- (3) Applied to P1.0/T2, P1.1/RXD, P1.2/TXD, P1.3/SYNC/SCK, P1.4/CAP, P1.5, P1.6, P1.7, P2.0/NMI, P2.1, P2.2, P2.3, P2.4, P2.5, P2.6/AOPWM0, P2.7/AOPWM1, P3.0/INT2/CS1, P3.1/AOPWM2, P3.2/INT0, P3.3/INT1, P3.5/T1, P3.6/RXD1, P3.7/TXD1, P5.1/TMS, P5.2/TDO, P5.3/TDI, GATEKILL, PWMUL, PWMUH, PWMVL, PWMVH, PWMWL, and PWMWH pins.

6.4 PLL and Oscillator DC characteristics

| Symbol | Parameter | Min | Typ | Max | Condition |
|---------------------|-------------------------------|----------------------------|-------|----------------------------|-----------------------------------|
| V _{PLLVD} | Supply Voltage | 1.62 V | 1.8 V | 1.92 V | Recommended |
| V _{IL OSC} | Oscillator Input Low Voltage | V _{PLLSS} | - | 0.2* V _{PLLVD} | V _{PLLVD} = 1.8 V (1) |
| V _{IH OSC} | Oscillator Input High Voltage | 0.8* V _{PLLVD} | | V _{PLLVD} | V _{PLLVD} = 1.8 V (1) |

Table 4. PLL DC Characteristics

Note:

(1) Data guaranteed by design.

6.5 Analog I/O DC Characteristics

- OP amp for current sensing (IFB+, IFB-, IFBO)

C_{AREF} = 1nF, C_{MEXT} = 100nF. Unless specified, Ta = 25°C.

| Symbol | Parameter | Min | Typ | Max | Condition |
|----------------------|-------------------------------|--------------|--------|--------|---------------------------------|
| V _{AVDD} | Supply Voltage | 1.71 V | 1.8 V | 1.89 V | Recommended |
| V _{OFFSET} | Input Offset Voltage | - | - | 26 mV | V _{AVDD} = 1.8 V |
| V _I | Input Voltage Range | 0 V | | 1.2 V | Recommended |
| V _{OUTSW} | OP amp output operating range | 50 mV (1) | - | 1.2 V | V _{AVDD} = 1.8 V |
| C _{IN} | Input capacitance | - | 3.6 pF | - | (1) |
| R _{FDBK} | OP amp feedback resistor | 5 kΩ | - | 20 kΩ | Requested between IFBO and IFB- |
| OP _{GAINCL} | Operating Close loop Gain | 80 db | - | - | (1) |
| CMRR | Common Mode Rejection Ratio | - | 80 db | - | (1) |
| I _{SRC} | Op amp output source current | - | 1 mA | - | V _{OUT} = 0.6 V (1) |
| I _{SNK} | Op amp output sink current | - | 100 μA | - | V _{OUT} = 0.6 V (1) |

Table 5. Analog I/O DC Characteristics

Note:

(1) Data guaranteed by design.

6.6 Under Voltage Lockout DC characteristics

- Based on AVDD (1.8V)

Unless specified, $T_a = 25^\circ\text{C}$.

| Symbol | Parameter | Min | Typ | Max | Condition |
|------------|-------------------------------|--------|--------|--------|--------------------------|
| UV_{CC+} | UVcc positive going Threshold | 1.53 V | 1.66 V | 1.71 V | $V_{DD1} = 3.3\text{ V}$ |
| UV_{CC-} | UVcc negative going Threshold | 1.52 V | 1.62 V | 1.71 V | $V_{DD1} = 3.3\text{ V}$ |
| UV_{CCH} | UVcc Hysteresys | - | 40 mV | - | |

Table 6. UVcc DC Characteristics

6.7 CMEXT and AREF Characteristics

$C_{AREF} = 1\text{nF}$, $C_{MEXT} = 100\text{nF}$. Unless specified, $T_a = 25^\circ\text{C}$.

| Symbol | Parameter | Min | Typ | Max | Condition |
|--------------|----------------------------------|--------|--------|--------|---------------------------|
| V_{CM} | CMEXT voltage | 495 mV | 600 mV | 700 mV | $V_{AVDD} = 1.8\text{ V}$ |
| V_{AREF} | Buffer Output Voltage | 495 mV | 600 mV | 700 mV | $V_{AVDD} = 1.8\text{ V}$ |
| ΔV_o | Load regulation ($V_{DC}-0.6$) | - | 1 mV | - | ⁽¹⁾ |
| PSRR | Power Supply Rejection Ratio | - | 75 db | - | ⁽¹⁾ |

Table 7. CMEXT and AREF DC Characteristics

7 AC Characteristics

7.1 PLL AC Characteristics

| Symbol | Parameter | Min | Typ | Max | Condition |
|-------------|-----------------------------|----------------------|----------|---------------|--------------------------------------|
| F_{CLKIN} | Crystal input frequency | 3.2 MHz | 4 MHz | 60 MHz | ⁽¹⁾ (see figure below) |
| F_{PLL} | Internal clock frequency | 32 MHz | 50 MHz | 128 MHz | ⁽¹⁾ |
| F_{LWPW} | Sleep mode output frequency | $F_{CLKIN} \div 256$ | - | - | ⁽¹⁾ |
| J_S | Short time jitter | - | 200 psec | - | ⁽¹⁾ |
| D | Duty cycle | - | 50 % | - | ⁽¹⁾ |
| T_{LOCK} | PLL lock time | - | - | 500 μ sec | ⁽¹⁾ |

Table 8. PLL AC Characteristics

Note:

(1) Data guaranteed by design.

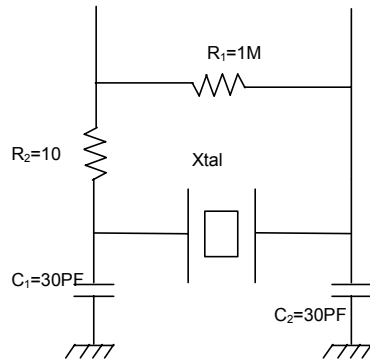

7.2 Analog to Digital Converter AC Characteristics

Unless specified, $T_a = 25^\circ\text{C}$.

| Symbol | Parameter | Min | Typ | Max | Condition |
|-------------------|-------------------------------|-----|-----|----------------------|---|
| T_{CONV} | Conversion time | - | - | 2.05 μsec | ⁽¹⁾ |
| T_{HOLD} | Sample/Hold maximum hold time | - | - | 10 μsec | Voltage droop \leq 15 LSB (see figure below) |

Table 9. A/D Converter AC Characteristics

Note:

(1) Data guaranteed by design.

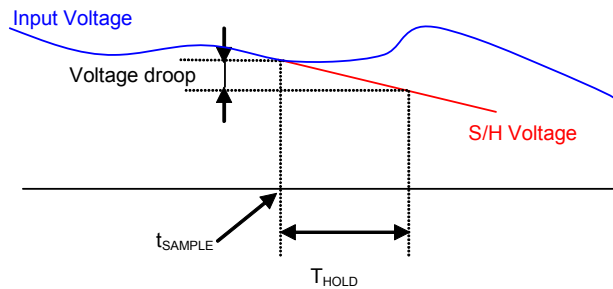

7.3 Op amp AC Characteristics

- OP amp for current sensing (IFB+, IFB-, IFBO)

Unless specified, Ta = 25°C.

| Symbol | Parameter | Min | Typ | Max | Condition |
|-------------------|--------------------|-----|-------------------|-----|--|
| OP _{SR} | OP amp slew rate | - | 10 V/μsec | - | V _{AVDD} = 1.8 V, CL = 33 pF ⁽¹⁾ |
| OP _{IMP} | OP input impedance | - | 10 ⁸ Ω | - | (1) |
| T _{SET} | Settling time | - | 400 ns | - | V _{AVDD} = 1.8 V, CL = 33 pF ⁽¹⁾ |

Table 10. Current Sensing OP Amp AC Characteristics

Note:

(1) Data guaranteed by design.

7.4 SYNC to SVPWM and A/D Conversion AC Timing

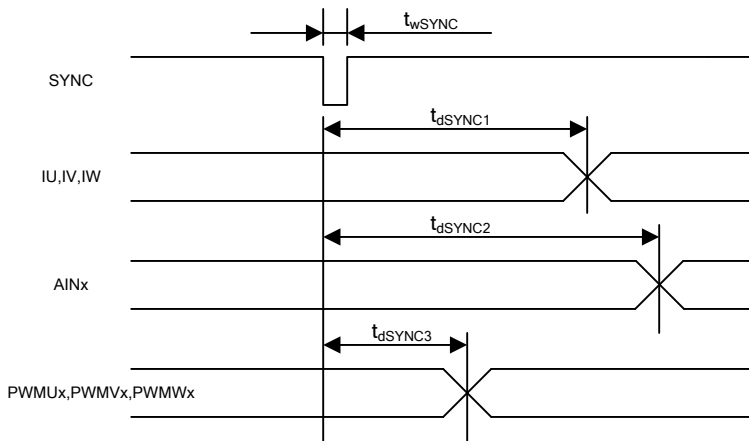

Unless specified, $T_a = 25^\circ\text{C}$.

| Symbol | Parameter | Min | Typ | Max | Unit |
|---------------------|---|-----|-----|-----|-----------------------|
| $t_{w\text{SYNC}}$ | SYNC pulse width | - | 32 | - | SYSClk |
| $t_{d\text{SYNC}1}$ | SYNC to current feedback conversion time | - | - | 100 | SYSClk |
| $t_{d\text{SYNC}2}$ | SYNC to AIN0-6 analog input conversion time | - | - | 200 | SYSClk ⁽¹⁾ |
| $t_{d\text{SYNC}3}$ | SYNC to PWM output delay time | - | - | 2 | SYSClk |

Table 11. SYNC AC Characteristics

Note:

(1) AIN1 through AIN6 channels are converted once every 6 SYNC events

7.5 GATEKILL to SVPWM AC Timing

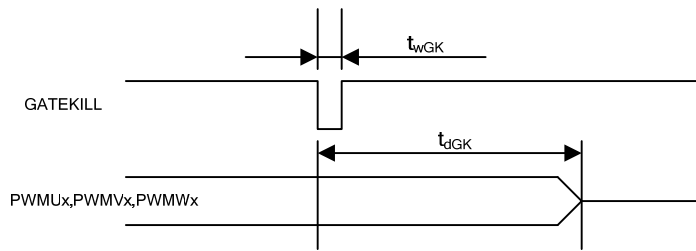

Unless specified, Ta = 25°C.

| Symbol | Parameter | Min | Typ | Max | Unit |
|-----------|------------------------------|-----|-----|-----|--------|
| t_{wGK} | GATEKILL pulse width | 32 | - | - | SYSClk |
| t_{dGK} | GATEKILL to PWM output delay | - | - | 100 | SYSClk |

Table 12. GATEKILL to SVPWM AC Timing

7.6 Interrupt AC Timing

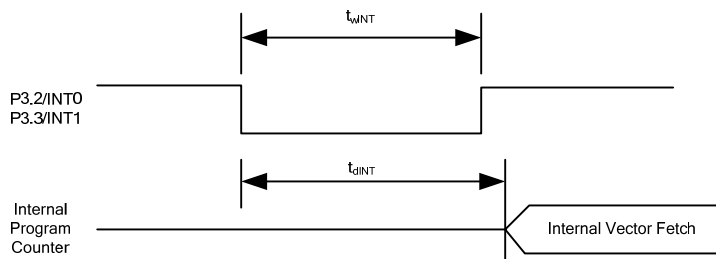

Unless specified, Ta = 25°C.

| Symbol | Parameter | Min | Typ | Max | Unit |
|------------|-------------------------------------|-----|-----|-----|--------|
| t_{wINT} | INT0, INT1 Interrupt Assertion Time | 4 | - | - | SYSClk |
| t_{dINT} | INT0, INT1 latency | - | - | 4 | SYSClk |

Table 13. Interrupt AC Timing

7.7 I²C AC Timing

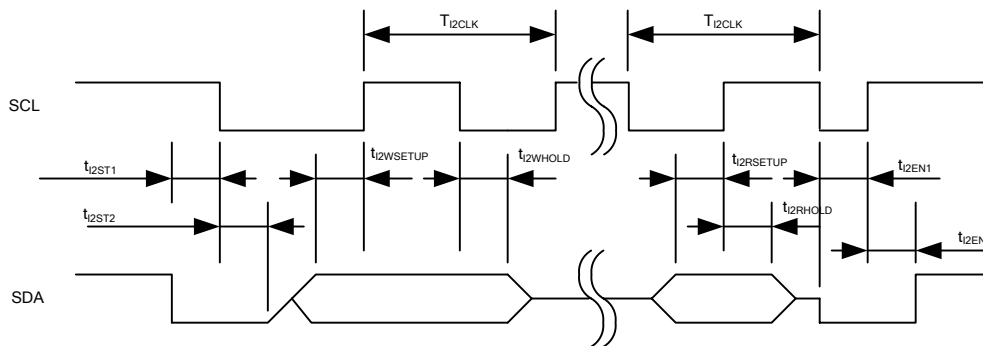

Unless specified, $T_a = 25^\circ\text{C}$.

| Symbol | Parameter | Min | Typ | Max | Unit |
|----------------|-----------------------------------|---|-----|------|-------------|
| T_{I2CLK} | I ² C clock period | 10 | - | 8192 | SYCLK |
| t_{I2ST1} | I ² C SDA start time | 0.25 | - | - | T_{I2CLK} |
| t_{I2ST2} | I ² C SCL start time | 0.25 | - | - | T_{I2CLK} |
| $t_{I2WSETUP}$ | I ² C write setup time | 0.25 | - | - | T_{I2CLK} |
| $t_{I2WHOLD}$ | I ² C write hold time | 0.25 | - | - | T_{I2CLK} |
| $t_{I2RSETUP}$ | I ² C read setup time | I ² C filter time ⁽¹⁾ | - | - | SYCLK |
| $t_{I2RHOLD}$ | I ² C read hold time | 1 | - | - | SYCLK |

Table 14. I²C AC Timing

Note:

- (1) I²C read setup time is determined by the programmable filter time applied to I²C communication.

7.8 SPI AC Timing

7.8.1 SPI Write AC timing

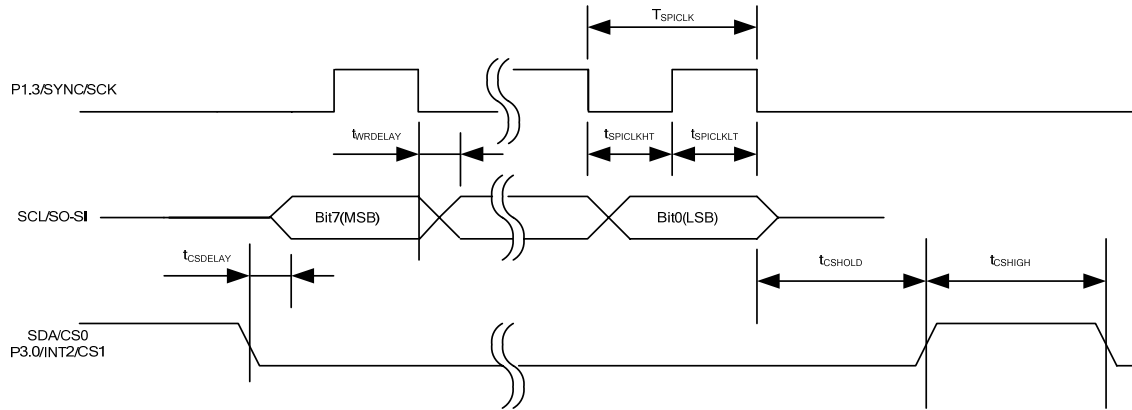

Unless specified, $T_a = 25^\circ\text{C}$.

| Symbol | Parameter | Min | Typ | Max | Unit |
|-----------------------|--|-----|-----|-----|---------------------|
| T_{SPICLK} | SPI clock period | 4 | - | - | SYSCLK |
| t_{SPICLKHT} | SPI clock high time | - | 1/2 | - | T_{SPICLK} |
| t_{SPICLKLT} | SPI clock low time | - | 1/2 | - | T_{SPICLK} |
| t_{CSDELAY} | CS to data delay time | - | - | 10 | nsec |
| t_{WRDELAY} | CLK falling edge to data delay time | - | - | 10 | nsec |
| t_{CSHIGH} | CS high time between two consecutive byte transfer | 1 | - | - | T_{SPICLK} |
| t_{CSHOLD} | CS hold time | - | 1 | - | T_{SPICLK} |

Table 15. SPI Write AC Timing

7.8.2 SPI Read AC Timing

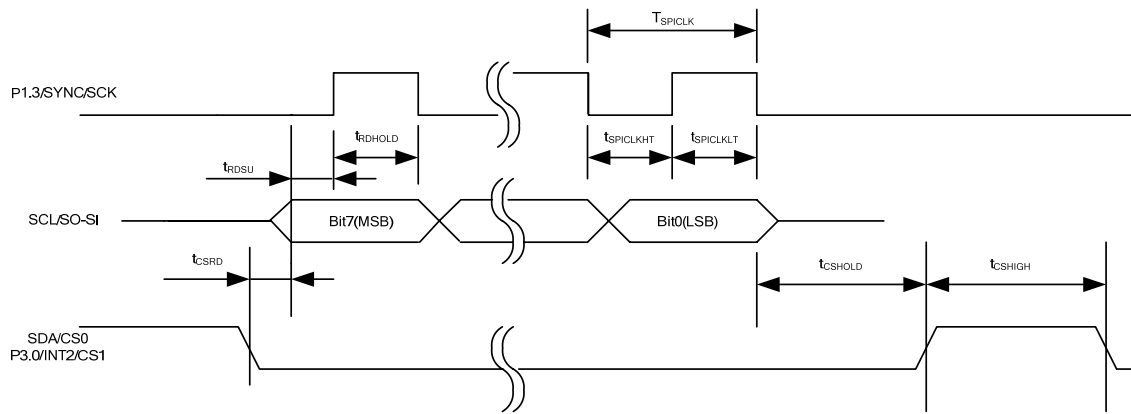

Unless specified, $T_a = 25^\circ\text{C}$.

| Symbol | Parameter | Min | Typ | Max | Unit |
|-----------------------|--|-----|-----|-----|---------------------|
| T_{SPICLK} | SPI clock period | 4 | - | - | SYSCCLK |
| t_{SPICLKHT} | SPI clock high time | - | 1/2 | - | T_{SPICLK} |
| t_{SPICLKLT} | SPI clock low time | - | 1/2 | - | T_{SPICLK} |
| t_{CSRDL} | CS to data delay time | - | - | 10 | nsec |
| t_{RDSU} | SPI read data setup time | 10 | - | - | nsec |
| t_{RDHOLD} | SPI read data hold time | 10 | - | - | nsec |
| t_{CSHIGH} | CS high time between two consecutive byte transfer | 1 | - | - | T_{SPICLK} |
| t_{CSHOLD} | CS hold time | - | 1 | - | T_{SPICLK} |

Table 16. SPI Read AC Timing

7.9 UART AC Timing

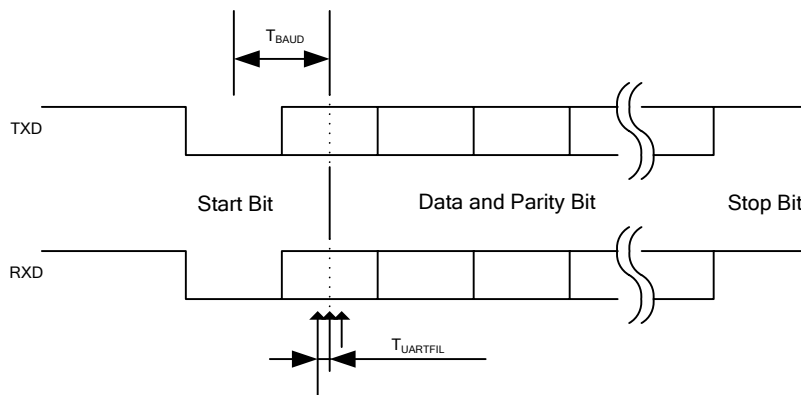

Unless specified, $T_a = 25^\circ\text{C}$.

| Symbol | Parameter | Min | Typ | Max | Unit |
|---------------|--|-----|-------|-----|------------|
| T_{BAUD} | Baud Rate Period | - | 57600 | - | bit/sec |
| $T_{UARTFIL}$ | UART sampling filter period ⁽¹⁾ | - | 1/16 | - | T_{BAUD} |

Table 17. UART AC Timing

Note:

- (1) Each bit including start and stop bit is sampled three times at center of a bit at an interval of $1/16 T_{BAUD}$. If three sampled values do not agree, then UART noise error is generated.

7.10 CAPTURE Input AC Timing

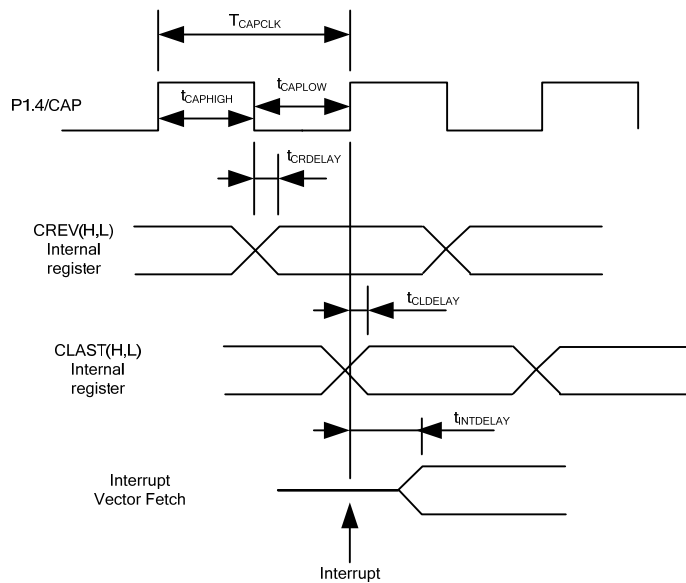

Unless specified, $T_a = 25^\circ\text{C}$.

| Symbol | Parameter | Min | Typ | Max | Unit |
|----------------|---|-----|-----|-----|-------|
| T_{CAPCLK} | CAPTURE input period | 8 | - | - | SYCLK |
| $t_{CAPHIGH}$ | CAPTURE input high time | 4 | - | - | SYCLK |
| t_{CAPLOW} | CAPTURE input low time | 4 | - | - | SYCLK |
| $t_{CRDELAY}$ | CAPTURE falling edge to capture register latch time | - | - | 4 | SYCLK |
| $t_{CLDELAY}$ | CAPTURE rising edge to capture register latch time | - | - | 4 | SYCLK |
| $t_{INTDELAY}$ | CAPTURE input interrupt latency time | - | - | 4 | SYCLK |

Table 18. CAPTURE AC Timing

7.11 JTAG AC Timing

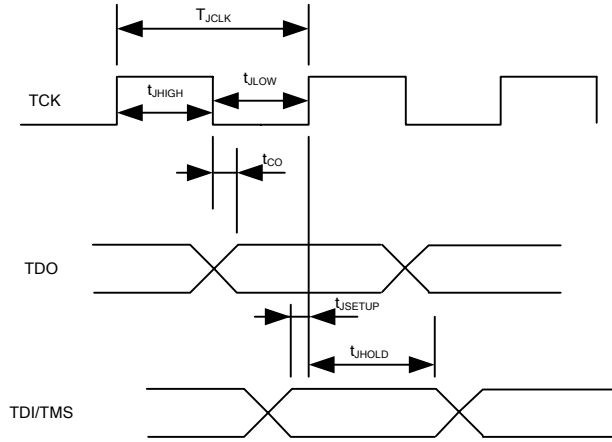

Unless specified, $T_a = 25^\circ\text{C}$.

| Symbol | Parameter | Min | Typ | Max | Unit |
|--------------|-----------------------------------|-----|-----|-----|------|
| T_{JCLK} | TCK Period | - | - | 50 | MHz |
| t_{JHIGH} | TCK High Period | 10 | - | - | nsec |
| t_{JLOW} | TCK Low Period | 10 | - | - | nsec |
| t_{CO} | TCK to TDO propagation delay time | 0 | - | 5 | nsec |
| t_{JSETUP} | TDI/TMS setup time | 4 | - | - | nsec |
| t_{JHOLD} | TDI/TMS hold time | 0 | - | - | nsec |

Table 19. JTAG AC Timing

8 Pin List

| Pin Number | Pin Name | Internal Pull-up /Pull-down | Pin Type | Description |
|------------|---------------|-----------------------------|----------|---|
| 1 | XTAL0 | | I | Crystal input |
| 2 | XTAL1 | | O | Crystal output |
| 3 | P1.0/T2 | | I/O | Discrete programmable I/O or Timer/Counter 2 input |
| 4 | P1.1/RXD | | I/O | Discrete programmable I/O or UART receive input |
| 5 | P1.2/TXD | | I/O | Discrete programmable I/O or UART transmit output |
| 6 | P1.3/SYNC/SCK | | I/O | Discrete programmable I/O or SYNC output or SPI clock output, needs to be pulled up to VDD1 in order to boot from I ² C EEPROM |
| 7 | P1.4/CAP | | I/O | Discrete programmable I/O or Capture timer input |
| 8 | P1.5 | | I/O | Discrete programmable I/O |
| 9 | P1.6 | | I/O | Discrete programmable I/O |
| 10 | P1.7 | | I/O | Discrete programmable I/O |
| 11 | VDD2 | | P | 1.8V digital power |
| 12 | VSS | | P | Digital common |
| 13 | VDD1 | | P | 3.3V digital power |
| 14 | P2.0/NMI | | I/O | Discrete programmable I/O or Non-maskable Interrupt input |
| 15 | P2.1 | | I/O | Discrete programmable I/O |
| 16 | P2.2 | | I/O | Discrete programmable I/O |
| 17 | P2.3 | | I/O | Discrete programmable I/O |
| 18 | P2.4 | | I/O | Discrete programmable I/O |
| 19 | P2.5 | | I/O | Discrete programmable I/O |
| 20 | P2.6/AOPWM0 | | I/O | Discrete programmable I/O or PWM 0 digital output |
| 21 | P2.7/AOPWM1 | | I/O | Discrete programmable I/O or PWM 1 digital output |
| 22 | VDD2 | | P | 1.8V digital power |
| 23 | VSS | | P | Digital common |
| 24 | AIN0 | | I | Analog input channel 0, 0-1.2V range, needs to be pulled down to AVSS if unused |
| 25 | AVDD | | P | 1.8V analog power |
| 26 | AVSS | | P | Analog common |
| 27 | AIN1 | | I | Analog input channel 1, 0-1.2V range, needs to be pulled down to AVSS if unused |
| 28 | CMEXT | | O | Unbuffered 0.6V output. Capacitor needs to be connected. |
| 29 | AREF | | O | Analog reference voltage output (0.6V) |
| 30 | IFB- | | I | Single shunt current sensing OP amp input (-) |
| 31 | IFB+ | | I | Single shunt current sensing OP amp input (+) |
| 32 | IFBO | | O | Single shunt current sensing OP amp output |

| Pin Number | Pin Name | Internal Pull-up /Pull-down | Pin Type | Description |
|------------|---------------|-----------------------------|----------|--|
| 33 | AIN2 | | I | Analog input channel 2, 0-1.2V range, needs to be pulled down to AVSS if unused |
| 34 | AIN3 | | I | Analog input channel 3, 0-1.2V range, needs to be pulled down to AVSS if unused |
| 35 | AIN4 | | I | Analog input channel 4, 0-1.2V range, needs to be pulled down to AVSS if unused |
| 36 | AIN5 | | I | Analog input channel 5, 0-1.2V range, needs to be pulled down to AVSS if unused |
| 37 | AIN6 | | I | Analog input channel 6, 0-1.2V range, needs to be pulled down to AVSS if unused |
| 38 | VDD2 | | P | 1.8V digital power |
| 39 | VSS | | P | Digital common |
| 40 | VDD1 | | P | 3.3V digital power |
| 41 | GATEKILL | | I | PWM shutdown input, 2- μ sec digital filter, configurable either high or low true. |
| 42 | PWMWL | 70 k Ω Pull up | O | PWM gate drive for phase W low side, configurable either high or low true |
| 43 | PWMWH | 70 k Ω Pull up | O | PWM gate drive for phase W high side, configurable either high or low true |
| 44 | PWMVL | 70 k Ω Pull up | O | PWM gate drive for phase V low side, configurable either high or low true |
| 45 | PWMVH | 70 k Ω Pull up | O | PWM gate drive for phase V high side, configurable either high or low true |
| 46 | PWMUL | 70 k Ω Pull up | O | PWM gate drive for phase U low side, configurable either high or low true |
| 47 | PWMUH | 70 k Ω Pull up | O | PWM gate drive for phase U high side, configurable either high or low true |
| 48 | P3.0/INT2/CS1 | | I/O | Discrete programmable I/O or external interrupt 2 input or SPI Chip Select 1 |
| 49 | P3.1/AOPWM2 | | I/O | Discrete programmable I/O or PWM 2 digital output |
| 50 | P3.2/INT0 | | I/O | Discrete programmable I/O or Interrupt 0 input |
| 51 | P3.3/INT1 | | I/O | Discrete programmable I/O or Interrupt 1 input |
| 52 | P3.5/T1 | | I/O | Discrete programmable I/O or Timer/Counter 1 |
| 53 | VSS | | P | Digital common |
| 54 | VDD1 | | P | 3.3V digital power |
| 55 | SCL/SO-SI | | I/O | I ² C clock output (open drain, need pull up) or SPI data |
| 56 | SDA/CS0 | | I/O | I ² C data (open drain, need pull up) or SPI Chip Select 0 |
| 57 | P5.1/TMS | | I/O | JTAG test mode select |
| 58 | P5.2/TDO | | I/O | JTAG test data output |
| 59 | P5.3/TDI | | I/O | JTAG test data input |
| 60 | TCK | | I | JTAG test clock |

| Pin Number | Pin Name | Internal Pull-up /Pull-down | Pin Type | Description |
|------------|----------|-----------------------------|----------|--|
| 61 | TSTMOD | 58 kΩ pull down | I | Test mode. Must be tied to VSS. Factory use only |
| 62 | RESET | | I/O | Reset, low true, Schmitt trigger input |
| 63 | PLLVDD | | P | 1.8V PLL power |
| 64 | PLLVSS | | P | PLL ground |

Table 20. Pin List

9 Package Dimensions

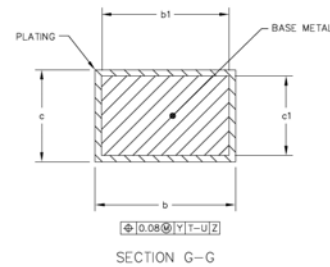
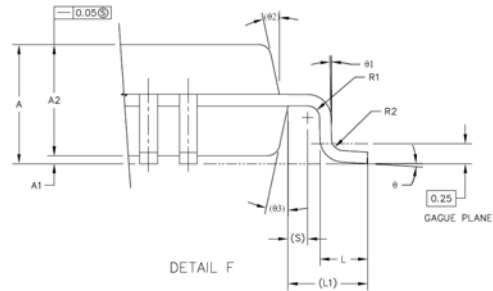
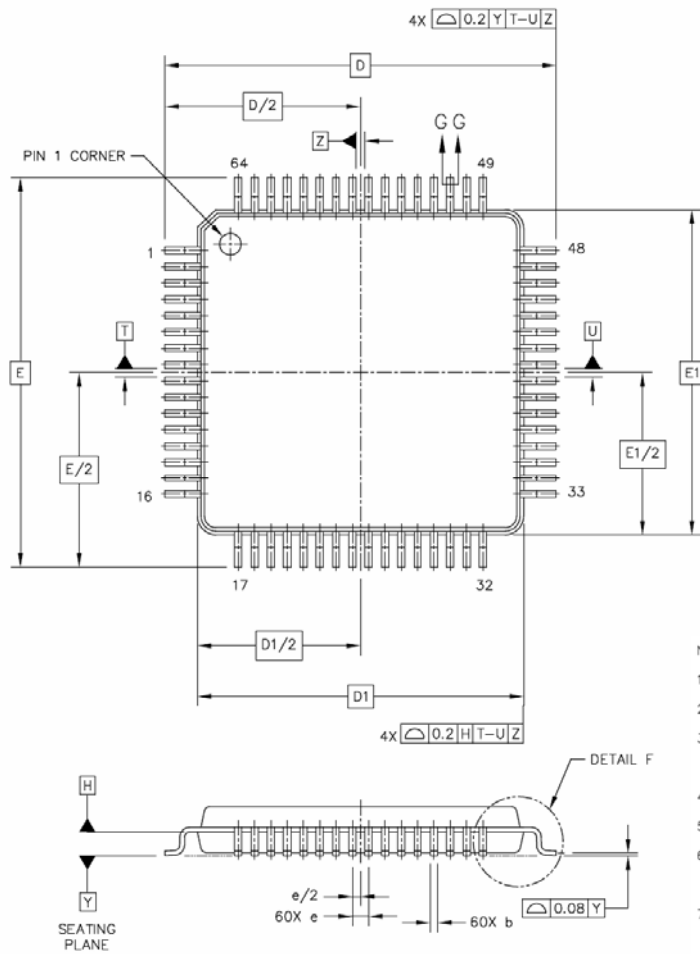

NOTES:

1. DIMENSIONS ARE IN MILLIMETERS.
2. INTERPRET DIMENSIONS AND TOLERANCES PER ASME Y14.5M-1994.
3. DATUM PLANE DATUM H IS LOCATED AT BOTTOM OF LEAD AND IS COINCIDENT WITH THE LEAD WHERE THE LEAD EXITS THE PLASTIC BODY AT THE BOTTOM OF THE PARTING LINE.
4. DATUM T, U, AND Z TO BE DETERMINED AT DATUM PLANE H.
5. DIMENSIONS D AND E TO BE DETERMINED AT SEATING PLANE DATUM Y.
6. DIMENSIONS D1 AND E1 DO NOT INCLUDE MOLD PROTRUSION. ALLOWABLE PROTRUSION IS 0.25 PER SIDE. DIMENSIONS D1 AND E1 DO INCLUDE MOLD MISMATCH AND ARE DETERMINED AT DATUM PLANE DATUM H.
7. DIMENSION b DOES NOT INCLUDE DAMBAR PROTRUSION. DAMBAR PROTRUSION SHALL NOT CAUSE THE b DIMENSION TO EXCEED 0.35. MINIMUM SPACE BETWEEN PROTRUSION AND ADJACENT LEAD OR PROTRUSION 0.07.

| DIM | MIN | MAX | DIM | MIN | MAX | DIM | MIN | MAX |
|-----|------|---------|-----|---------|-----|-----|-----|-----|
| A | --- | 1.6 | L1 | 1 REF | | | | |
| A1 | 0.05 | 0.15 | R1 | 0.1 | 0.2 | | | |
| A2 | 1.35 | 1.45 | R2 | 0.1 | 0.2 | | | |
| b | 0.17 | 0.27 | S | 0.2 REF | | | | |
| b1 | 0.17 | 0.23 | θ | 0° | 7° | | | |
| c | 0.09 | 0.2 | θ1 | 0° | --- | | | |
| c1 | 0.09 | 0.16 | θ2 | 12° REF | | | | |
| D | | 12 BSC | θ3 | 12° REF | | | | |
| D1 | | 10 BSC | | | | | | |
| e | | 0.5 BSC | | | | | | |
| E | | 12 BSC | | | | | | |
| E1 | | 10 BSC | | | | | | |
| L | 0.45 | 0.75 | | | | | | |

10 Part Marking Information

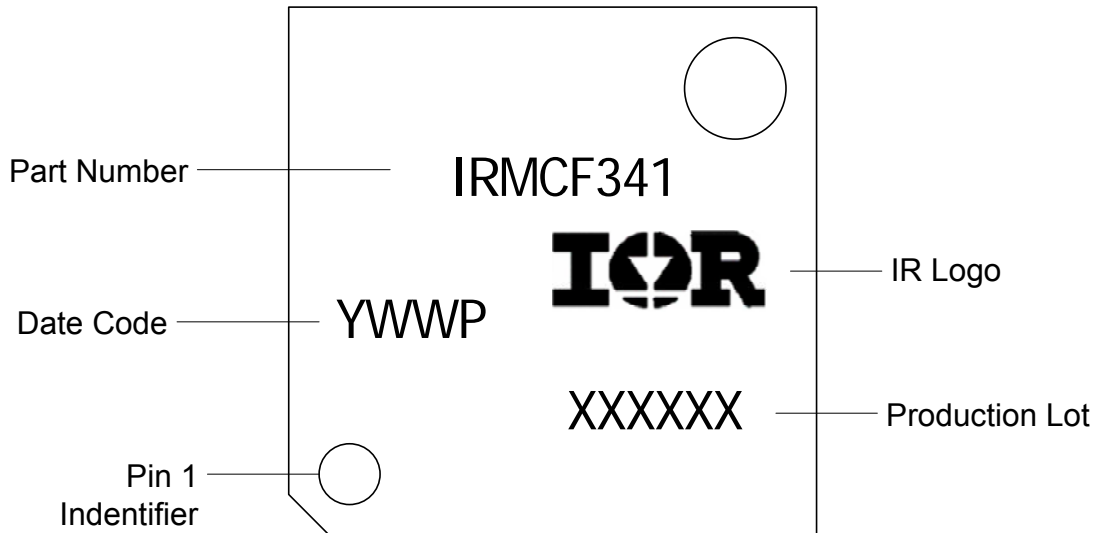

Order Information

Lead-Free Part in 64-lead QFP
Moisture sensitivity rating – MSL3

| Part number | Order quantities |
|-------------|--|
| IRMCF341TR | 1500 parts on tape and reel in dry pack |
| IRMCF341TY | 1600 parts on trays (160 parts per tray) in dry pack |

International
IOR Rectifier

The LQFP-64 is MSL3 qualified
 This product has been designed and qualified for the industrial level
 Qualification standards can be found at www.irf.com <<http://www.irf.com>>
 IR WORLD HEADQUARTERS: 233 Kansas St., El Segundo, California 90245, Tel: (310) 252-7105
 Data and specifications subject to change without notice. 12/05/2006