

R8C/33G Group, R8C/33H Group

User's Manual: Hardware

RENESAS MCU
R8C Family / R8C/3x Series

All information contained in these materials, including products and product specifications, represents information on the product at the time of publication and is subject to change by Renesas Electronics Corp. without notice. Please review the latest information published by Renesas Electronics Corp. through various means, including the Renesas Electronics Corp. website (<http://www.renesas.com>).

Notice

1. Descriptions of circuits, software and other related information in this document are provided only to illustrate the operation of semiconductor products and application examples. You are fully responsible for the incorporation of these circuits, software, and information in the design of your equipment. Renesas Electronics assumes no responsibility for any losses incurred by you or third parties arising from the use of these circuits, software, or information.
2. Renesas Electronics has used reasonable care in preparing the information included in this document, but Renesas Electronics does not warrant that such information is error free. Renesas Electronics assumes no liability whatsoever for any damages incurred by you resulting from errors in or omissions from the information included herein.
3. Renesas Electronics does not assume any liability for infringement of patents, copyrights, or other intellectual property rights of third parties by or arising from the use of Renesas Electronics products or technical information described in this document. No license, express, implied or otherwise, is granted hereby under any patents, copyrights or other intellectual property rights of Renesas Electronics or others.
4. You should not alter, modify, copy, or otherwise misappropriate any Renesas Electronics product, whether in whole or in part. Renesas Electronics assumes no responsibility for any losses incurred by you or third parties arising from such alteration, modification, copy or otherwise misappropriation of Renesas Electronics product.
5. Renesas Electronics products are classified according to the following two quality grades: "Standard" and "High Quality". The recommended applications for each Renesas Electronics product depends on the product's quality grade, as indicated below.
"Standard": Computers; office equipment; communications equipment; test and measurement equipment; audio and visual equipment; home electronic appliances; machine tools; personal electronic equipment; and industrial robots etc.
"High Quality": Transportation equipment (automobiles, trains, ships, etc.); traffic control systems; anti-disaster systems; anti-crime systems; and safety equipment etc.

Renesas Electronics products are neither intended nor authorized for use in products or systems that may pose a direct threat to human life or bodily injury (artificial life support devices or systems, surgical implantations etc.), or may cause serious property damages (nuclear reactor control systems, military equipment etc.). You must check the quality grade of each Renesas Electronics product before using it in a particular application. You may not use any Renesas Electronics product for any application for which it is not intended. Renesas Electronics shall not be in any way liable for any damages or losses incurred by you or third parties arising from the use of any Renesas Electronics product for which the product is not intended by Renesas Electronics.
6. You should use the Renesas Electronics products described in this document within the range specified by Renesas Electronics, especially with respect to the maximum rating, operating supply voltage range, movement power voltage range, heat radiation characteristics, installation and other product characteristics. Renesas Electronics shall have no liability for malfunctions or damages arising out of the use of Renesas Electronics products beyond such specified ranges.
7. Although Renesas Electronics endeavors to improve the quality and reliability of its products, semiconductor products have specific characteristics such as the occurrence of failure at a certain rate and malfunctions under certain use conditions. Further, Renesas Electronics products are not subject to radiation resistance design. Please be sure to implement safety measures to guard them against the possibility of physical injury, and injury or damage caused by fire in the event of the failure of a Renesas Electronics product, such as safety design for hardware and software including but not limited to redundancy, fire control and malfunction prevention, appropriate treatment for aging degradation or any other appropriate measures. Because the evaluation of microcomputer software alone is very difficult, please evaluate the safety of the final products or systems manufactured by you.
8. Please contact a Renesas Electronics sales office for details as to environmental matters such as the environmental compatibility of each Renesas Electronics product. Please use Renesas Electronics products in compliance with all applicable laws and regulations that regulate the inclusion or use of controlled substances, including without limitation, the EU RoHS Directive. Renesas Electronics assumes no liability for damages or losses occurring as a result of your noncompliance with applicable laws and regulations.
9. Renesas Electronics products and technology may not be used for or incorporated into any products or systems whose manufacture, use, or sale is prohibited under any applicable domestic or foreign laws or regulations. You should not use Renesas Electronics products or technology described in this document for any purpose relating to military applications or use by the military, including but not limited to the development of weapons of mass destruction. When exporting the Renesas Electronics products or technology described in this document, you should comply with the applicable export control laws and regulations and follow the procedures required by such laws and regulations.
10. It is the responsibility of the buyer or distributor of Renesas Electronics products, who distributes, disposes of, or otherwise places the product with a third party, to notify such third party in advance of the contents and conditions set forth in this document, Renesas Electronics assumes no responsibility for any losses incurred by you or third parties as a result of unauthorized use of Renesas Electronics products.
11. This document may not be reproduced or duplicated in any form, in whole or in part, without prior written consent of Renesas Electronics.
12. Please contact a Renesas Electronics sales office if you have any questions regarding the information contained in this document or Renesas Electronics products, or if you have any other inquiries.

(Note 1) "Renesas Electronics" as used in this document means Renesas Electronics Corporation and also includes its majority-owned subsidiaries.

(Note 2) "Renesas Electronics product(s)" means any product developed or manufactured by or for Renesas Electronics.

General Precautions in the Handling of MPU/MCU Products

The following usage notes are applicable to all MPU/MCU products from Renesas. For detailed usage notes on the products covered by this document, refer to the relevant sections of the document as well as any technical updates that have been issued for the products.

1. Handling of Unused Pins

Handle unused pins in accordance with the directions given under Handling of Unused Pins in the manual.

- The input pins of CMOS products are generally in the high-impedance state. In operation with an unused pin in the open-circuit state, extra electromagnetic noise is induced in the vicinity of LSI, an associated shoot-through current flows internally, and malfunctions occur due to the false recognition of the pin state as an input signal become possible. Unused pins should be handled as described under Handling of Unused Pins in the manual.

2. Processing at Power-on

The state of the product is undefined at the moment when power is supplied.

- The states of internal circuits in the LSI are indeterminate and the states of register settings and pins are undefined at the moment when power is supplied.
In a finished product where the reset signal is applied to the external reset pin, the states of pins are not guaranteed from the moment when power is supplied until the reset process is completed. In a similar way, the states of pins in a product that is reset by an on-chip power-on reset function are not guaranteed from the moment when power is supplied until the power reaches the level at which resetting has been specified.

3. Prohibition of Access to Reserved Addresses

Access to reserved addresses is prohibited.

- The reserved addresses are provided for the possible future expansion of functions. Do not access these addresses; the correct operation of LSI is not guaranteed if they are accessed.

4. Clock Signals

After applying a reset, only release the reset line after the operating clock signal has become stable. When switching the clock signal during program execution, wait until the target clock signal has stabilized.

- When the clock signal is generated with an external resonator (or from an external oscillator) during a reset, ensure that the reset line is only released after full stabilization of the clock signal. Moreover, when switching to a clock signal produced with an external resonator (or by an external oscillator) while program execution is in progress, wait until the target clock signal is stable.

5. Differences between Products

Before changing from one product to another, i.e. to a product with a different part number, confirm that the change will not lead to problems.

- The characteristics of an MPU or MCU in the same group but having a different part number may differ in terms of the internal memory capacity, layout pattern, and other factors, which can affect the ranges of electrical characteristics, such as characteristic values, operating margins, immunity to noise, and amount of radiated noise. When changing to a product with a different part number, implement a system-evaluation test for the given product.

How to Use This Manual

1. Purpose and Target Readers

This manual is designed to provide the user with an understanding of the hardware functions and electrical characteristics of the MCU. It is intended for users designing application systems incorporating the MCU. A basic knowledge of electric circuits, logical circuits, and MCUs is necessary in order to use this manual.

The manual comprises an overview of the product; descriptions of the CPU, system control functions, peripheral functions, and electrical characteristics; and usage notes.

Particular attention should be paid to the precautionary notes when using the manual. These notes occur within the body of the text, at the end of each section, and in the Usage Notes section.

The revision history summarizes the locations of revisions and additions. It does not list all revisions. Refer to the text of the manual for details.

The following documents apply to the R8C/33G Group, R8C/33H Group. Make sure to refer to the latest versions of these documents. The newest versions of the documents listed may be obtained from the Renesas Electronics Web site.

Document Type	Description	Document Title	Document No.
Datasheet	Hardware overview and electrical characteristics	R8C/33G Group, R8C/33H Group Datasheet	R01DS0091EJ0100
User's manual: Hardware	Hardware specifications (pin assignments, memory maps, peripheral function specifications, electrical characteristics, timing charts) and operation description Note: Refer to the application notes for details on using peripheral functions.	R8C/33G Group, R8C/33H Group User's manual: Hardware	This User's manual
User's manual: Software	Description of CPU instruction set	R8C/Tiny Series Software Manual	REJ09B0001
Application note	Information on using peripheral functions and application examples Sample programs Information on writing programs in assembly language and C	Available from Renesas Electronics Web site.	
Renesas technical update	Product specifications, updates on documents, etc.		

2. Notation of Numbers and Symbols

The notation conventions for register names, bit names, numbers, and symbols used in this manual are described below.

(1) Register Names, Bit Names, and Pin Names

Registers, bits, and pins are referred to in the text by symbols. The symbol is accompanied by the word “register,” “bit,” or “pin” to distinguish the three categories.

Examples the PM03 bit in the PM0 register
 P3_5 pin, VCC pin

(2) Notation of Numbers

The indication “b” is appended to numeric values given in binary format. However, nothing is appended to the values of single bits. The indication “h” is appended to numeric values given in hexadecimal format. Nothing is appended to numeric values given in decimal format.

Examples Binary: 11b
 Hexadecimal: EFA0h
 Decimal: 1234

3. Register Notation

The symbols and terms used in register diagrams are described below.

x.x.x XXX Register (Symbol)

Address XXXXh

Bit	b7	b6	b5	b4	b3	b2	b1	b0	
Symbol	XXX7	XXX6	XXX5	XXX4	—	—	XXX1	XXX0	*1
After Reset	0	0	0	0	0	0	0	0	

Bit	Symbol	Bit Name	Function	R/W
b0	XXX0	XXX bit	b1 b0 0 0: XXX 0 1: XXX 1 0: Do not set. 1 1: XXX	R/W
b1	XXX1			R/W
b2	—	Nothing is assigned. If necessary, set to 0. When read, the content is undefined.		—
b3	—	Reserved bit	Set to 0.	R/W
b4	XXX4	XXX bit	Function varies according to the operating mode.	R/W
b5	XXX5			W
b6	XXX6			R/W
b7	XXX7	XXX bit	0: XXX 1: XXX	R

*1

- R/W: Read and write.
- R: Read only.
- W: Write only.
- : Nothing is assigned.

*2

- Reserved bit
Reserved bit. Set to specified value.

*3

- Nothing is assigned.
Nothing is assigned to the bit. As the bit may be used for future functions, if necessary, set to 0.
- Do not set to a value.
Operation is not guaranteed when a value is set.
- Function varies according to the operating mode.
The function of the bit varies with the peripheral function mode. Refer to the register diagram for information on the individual modes.

4. List of Abbreviations and Acronyms

Abbreviation	Full Form
ACIA	Asynchronous Communication Interface Adapter
bps	bits per second
CRC	Cyclic Redundancy Check
DMA	Direct Memory Access
DMAC	Direct Memory Access Controller
GSM	Global System for Mobile Communications
Hi-Z	High Impedance
IEBus	Inter Equipment Bus
I/O	Input/Output
IrDA	Infrared Data Association
LSB	Least Significant Bit
MSB	Most Significant Bit
NC	Non-Connect
PLL	Phase Locked Loop
PWM	Pulse Width Modulation
SIM	Subscriber Identity Module
UART	Universal Asynchronous Receiver/Transmitter
VCO	Voltage Controlled Oscillator

Table of Contents

SFR Page Reference	B - 1
1. Overview	1
1.1 Features	1
1.1.1 Applications	1
1.1.2 Specifications	2
1.2 Product List	6
1.3 Block Diagram	8
1.4 Pin Assignment	9
1.5 Pin Functions	11
2. Central Processing Unit (CPU)	13
2.1 Data Registers (R0, R1, R2, and R3)	14
2.2 Address Registers (A0 and A1)	14
2.3 Frame Base Register (FB)	14
2.4 Interrupt Table Register (INTB)	14
2.5 Program Counter (PC)	14
2.6 User Stack Pointer (USP) and Interrupt Stack Pointer (ISP)	14
2.7 Static Base Register (SB)	14
2.8 Flag Register (FLG)	14
2.8.1 Carry Flag (C)	14
2.8.2 Debug Flag (D)	14
2.8.3 Zero Flag (Z)	14
2.8.4 Sign Flag (S)	14
2.8.5 Register Bank Select Flag (B)	14
2.8.6 Overflow Flag (O)	14
2.8.7 Interrupt Enable Flag (I)	15
2.8.8 Stack Pointer Select Flag (U)	15
2.8.9 Processor Interrupt Priority Level (IPL)	15
2.8.10 Reserved Bit	15
3. Memory	16
3.1 R8C/33G Group	16
3.2 R8C/33H Group	17
4. Special Function Registers (SFRs)	18
5. Resets	30
5.1 Registers	32
5.1.1 Processor Mode Register 0 (PM0)	32
5.1.2 Reset Source Determination Register (RSTFR)	32
5.1.3 Option Function Select Register (OFS)	33
5.1.4 Option Function Select Register 2 (OFS2)	34
5.2 Hardware Reset	35
5.2.1 When Power Supply is Stable	35
5.2.2 Power On	35
5.3 Power-On Reset Function	37
5.4 Voltage Monitor 0 Reset	38
5.5 Watchdog Timer Reset	39

5.6	Software Reset	39
5.7	Cold Start-Up/Warm Start-Up Determination Function	40
5.8	Reset Source Determination Function	40
6.	Voltage Detection Circuit	41
6.1	Overview	41
6.2	Registers	45
6.2.1	Voltage Monitor Circuit Control Register (CMPA)	45
6.2.2	Voltage Monitor Circuit Edge Select Register (VCAC)	46
6.2.3	Voltage Detect Register 1 (VCA1)	46
6.2.4	Voltage Detect Register 2 (VCA2)	47
6.2.5	Voltage Detection 1 Level Select Register (VD1LS)	48
6.2.6	Voltage Monitor 0 Circuit Control Register (VW0C)	49
6.2.7	Voltage Monitor 1 Circuit Control Register (VW1C)	50
6.2.8	Voltage Monitor 2 Circuit Control Register (VW2C)	51
6.2.9	Option Function Select Register (OFS)	52
6.3	VCC Input Voltage	53
6.3.1	Monitoring Vdet0	53
6.3.2	Monitoring Vdet1	53
6.3.3	Monitoring Vdet2	53
6.4	Voltage Monitor 0 Reset	54
6.5	Voltage Monitor 1 Interrupt	55
6.6	Voltage Monitor 2 Interrupt	57
7.	I/O Ports	59
7.1	Functions of I/O Ports	59
7.2	Effect on Peripheral Functions	60
7.3	Pins Other than I/O Ports	61
7.4	Registers	71
7.4.1	Port Pi Direction Register (PDi) (i = 0 to 1, 3 to 5)	71
7.4.2	Port Pi Register (Pi) (i = 0 to 1, 3 to 5)	72
7.4.3	Timer RA Pin Select Register (TRASR)	73
7.4.4	Timer RB/RC Pin Select Register (TRBRCSR)	73
7.4.5	Timer RC Pin Select Register 0 (TRCPSR0)	74
7.4.6	Timer RC Pin Select Register 1 (TRCPSR1)	75
7.4.7	Timer RD Pin Select Register 0 (TRDPSR0)	76
7.4.8	Timer RD Pin Select Register 1 (TRDPSR1)	76
7.4.9	UART0 Pin Select Register (U0SR)	77
7.4.10	UART2 Pin Select Register 0 (U2SR0)	78
7.4.11	UART2 Pin Select Register 1 (U2SR1)	78
7.4.12	SSU Pin Select Register (SSUICSR)	79
7.4.13	INT Interrupt Input Pin Select Register (INTSR)	80
7.4.14	I/O Function Pin Select Register (PINSR)	81
7.4.15	Pull-Up Control Register 0 (PUR0)	82
7.4.16	Pull-Up Control Register 1 (PUR1)	82
7.4.17	Input Threshold Control Register 0 (VLT0)	83
7.4.18	Input Threshold Control Register 1 (VLT1)	84
7.5	Port Settings	85
7.6	Unassigned Pin Handling	100

8.	Bus	101
9.	Clock Generation Circuit	103
9.1	Overview	103
9.2	Registers	106
9.2.1	System Clock Control Register 0 (CM0)	106
9.2.2	System Clock Control Register 1 (CM1)	107
9.2.3	System Clock Control Register 3 (CM3)	108
9.2.4	Oscillation Stop Detection Register (OCD)	110
9.2.5	High-Speed On-Chip Oscillator Control Register 7 (FRA7)	110
9.2.6	High-Speed On-Chip Oscillator Control Register 0 (FRA0)	111
9.2.7	High-Speed On-Chip Oscillator Control Register 1 (FRA1)	111
9.2.8	High-Speed On-Chip Oscillator Control Register 2 (FRA2)	112
9.2.9	High-Speed On-Chip Oscillator Control Register 4 (FRA4)	113
9.2.10	High-Speed On-Chip Oscillator Control Register 5 (FRA5)	113
9.2.11	High-Speed On-Chip Oscillator Control Register 6 (FRA6)	113
9.2.12	High-Speed On-Chip Oscillator Control Register 3 (FRA3)	113
9.2.13	Voltage Detect Register 2 (VCA2)	114
9.3	XIN Clock	115
9.4	On-Chip Oscillator Clock	116
9.4.1	Low-Speed On-Chip Oscillator Clock	116
9.4.2	High-Speed On-Chip Oscillator Clock	116
9.5	CPU Clock and Peripheral Function Clock	117
9.5.1	System Clock	117
9.5.2	CPU Clock	117
9.5.3	Peripheral Function Clock (f1, f2, f4, f8, and f32)	117
9.5.4	fOCO	117
9.5.5	fOCO40M	117
9.5.6	fOCO-F	117
9.5.7	fOCO-S	118
9.5.8	fOCO128	118
9.5.9	fOCO-WDT	118
9.6	Power Control	119
9.6.1	Standard Operating Mode	119
9.6.2	Wait Mode	121
9.6.3	Stop Mode	125
9.7	Oscillation Stop Detection Function	128
9.7.1	How to Use Oscillation Stop Detection Function	129
9.8	Notes on Clock Generation Circuit	132
9.8.1	Stop Mode	132
9.8.2	Wait Mode	132
9.8.3	Reducing Internal Power Using VCA20 Bit	133
9.8.4	Oscillation Stop Detection Function	133
9.8.5	Oscillation Circuit Constants	133
10.	Protection	134
10.1	Register	134
10.1.1	Protect Register (PRCR)	134

11.	Interrupts	135
11.1	Overview	135
11.1.1	Types of Interrupts	135
11.1.2	Software Interrupts	136
11.1.3	Special Interrupts	137
11.1.4	Peripheral Function Interrupts	137
11.1.5	Interrupts and Interrupt Vectors	138
11.2	Registers	140
11.2.1	Interrupt Control Register (S2TIC, S2RIC, KUPIC, ADIC, S0TIC, S0RIC, TRAIC, TRBIC, U2BCNIC, VCMP1IC, VCMP2IC)	140
11.2.2	Interrupt Control Register (FMRDYIC, TRCIC, TRD0IC, TRD1IC, SSUIC)	141
11.2.3	INT _i Interrupt Control Register (INT _i IC) (i = 0 to 1, 3)	142
11.3	Interrupt Control	143
11.3.1	I Flag	143
11.3.2	IR Bit	143
11.3.3	Bits ILVL2 to ILVL0, IPL	143
11.3.4	Interrupt Sequence	144
11.3.5	Interrupt Response Time	145
11.3.6	IPL Change when Interrupt Request is Acknowledged	145
11.3.7	Saving Registers	146
11.3.8	Returning from Interrupt Routine	148
11.3.9	Interrupt Priority	148
11.3.10	Interrupt Priority Level Selection Circuit	149
11.4	$\overline{\text{INT}}$ Interrupt	150
11.4.1	$\overline{\text{INT}}_i$ Interrupt (i = 0 to 1, 3)	150
11.4.2	INT Interrupt Input Pin Select Register (INTSR)	150
11.4.3	External Input Enable Register 0 (INTEN)	151
11.4.4	INT Input Filter Select Register 0 (INTF)	152
11.4.5	$\overline{\text{INT}}_i$ Input Filter (i = 0 to 1, 3)	153
11.5	Key Input Interrupt	154
11.5.1	Key Input Enable Register 0 (KIEN)	155
11.6	Address Match Interrupt	156
11.6.1	Address Match Interrupt Enable Register i (AIER _i) (i = 0 or 1)	157
11.6.2	Address Match Interrupt Register i (RMAD _i) (i = 0 or 1)	157
11.7	Timer RC Interrupt, Timer RD Interrupt, Synchronous Serial Communication Unit Interrupt, and Flash Memory Interrupt (Interrupts with Multiple Interrupt Request Sources).....	158
11.8	Notes on Interrupts	160
11.8.1	Reading Address 00000h	160
11.8.2	SP Setting	160
11.8.3	External Interrupt and Key Input Interrupt	160
11.8.4	Changing Interrupt Sources	161
11.8.5	Rewriting Interrupt Control Register	162
12.	ID Code Areas	163
12.1	Overview	163
12.2	Functions	164
12.3	Forced Erase Function	165
12.4	Standard Serial I/O Mode Disabled Function	165

12.5	Notes on ID Code Areas	166
12.5.1	Setting Example of ID Code Areas	166
13.	Option Function Select Area	167
13.1	Overview	167
13.2	Registers	168
13.2.1	Option Function Select Register (OFS)	168
13.2.2	Option Function Select Register 2 (OFS2)	169
13.3	Notes on Option Function Select Area	170
13.3.1	Setting Example of Option Function Select Area	170
14.	Watchdog Timer	171
14.1	Overview	171
14.2	Registers	173
14.2.1	Processor Mode Register 1 (PM1)	173
14.2.2	Watchdog Timer Reset Register (WDTR)	173
14.2.3	Watchdog Timer Start Register (WDTS)	173
14.2.4	Watchdog Timer Control Register (WDTC)	174
14.2.5	Count Source Protection Mode Register (CSPR)	174
14.2.6	Option Function Select Register (OFS)	175
14.2.7	Option Function Select Register 2 (OFS2)	176
14.3	Functional Description	177
14.3.1	Common Items for Multiple Modes	177
14.3.2	Count Source Protection Mode Disabled	178
14.3.3	Count Source Protection Mode Enabled	179
15.	DTC	180
15.1	Overview	180
15.2	Registers	181
15.2.1	DTC Control Register j (DTCCRj) (j = 0 to 23)	182
15.2.2	DTC Block Size Register j (DTBLSj) (j = 0 to 23)	182
15.2.3	DTC Transfer Count Register j (DTCCTj) (j = 0 to 23)	183
15.2.4	DTC Transfer Count Reload Register j (DTRLdj) (j = 0 to 23)	183
15.2.5	DTC Source Address Register j (DTSARj) (j = 0 to 23)	183
15.2.6	DTC Destination Address Register j (DTDARj) (j = 0 to 23)	183
15.2.7	DTC Activation Enable Register i (DTCENi) (i = 0 to 4, 6)	184
15.2.8	DTC Activation Control Register (DTCTL)	185
15.3	Function Description	186
15.3.1	Overview	186
15.3.2	Activation Sources	186
15.3.3	Control Data Allocation and DTC Vector Table	188
15.3.4	Normal Mode	193
15.3.5	Repeat Mode	194
15.3.6	Chain Transfers	195
15.3.7	Interrupt Sources	195
15.3.8	Operation Timings	196
15.3.9	Number of DTC Execution Cycles	197
15.3.10	DTC Activation Source Acknowledgement and Interrupt Source Flags	198
15.4	Notes on DTC	200

15.4.1	DTC activation source	200
15.4.2	DTCENi (i = 0 to 4, 6) Registers	200
15.4.3	Peripheral Modules	200
15.4.4	Interrupt Request	200
15.4.5	DTC Activation	200
15.4.6	DTC Chain Transfers	200
16.	General Overview of Timers	201
17.	Timer RA	202
17.1	Overview	202
17.2	Registers	203
17.2.1	Timer RA Control Register (TRACR)	203
17.2.2	Timer RA I/O Control Register (TRAIOC)	203
17.2.3	Timer RA Mode Register (TRAMR)	204
17.2.4	Timer RA Prescaler Register (TRAPRE)	204
17.2.5	Timer RA Register (TRA)	205
17.2.6	Timer RA Pin Select Register (TRASR)	205
17.3	Timer Mode	206
17.3.1	Timer RA I/O Control Register (TRAIOC) in Timer Mode	206
17.3.2	Timer Write Control during Count Operation	207
17.4	Pulse Output Mode	208
17.4.1	Timer RA I/O Control Register (TRAIOC) in Pulse Output Mode	209
17.5	Event Counter Mode	210
17.5.1	Timer RA I/O Control Register (TRAIOC) in Event Counter Mode	211
17.6	Pulse Width Measurement Mode	212
17.6.1	Timer RA I/O Control Register (TRAIOC) in Pulse Width Measurement Mode	213
17.6.2	Operating Example	214
17.7	Pulse Period Measurement Mode	215
17.7.1	Timer RA I/O Control Register (TRAIOC) in Pulse Period Measurement Mode	216
17.7.2	Operating Example	217
17.8	Notes on Timer RA	218
18.	Timer RB	219
18.1	Overview	219
18.2	Registers	220
18.2.1	Timer RB Control Register (TRBCR)	220
18.2.2	Timer RB One-Shot Control Register (TRBOCR)	220
18.2.3	Timer RB I/O Control Register (TRBIOC)	221
18.2.4	Timer RB Mode Register (TRBMR)	221
18.2.5	Timer RB Prescaler Register (TRBPRES)	222
18.2.6	Timer RB Secondary Register (TRBSC)	222
18.2.7	Timer RB Primary Register (TRBPR)	223
18.2.8	Timer RB/RC Pin Select Register (TRBRCSR)	223
18.3	Timer Mode	224
18.3.1	Timer RB I/O Control Register (TRBIOC) in Timer Mode	224
18.3.2	Timer Write Control during Count Operation	225
18.4	Programmable Waveform Generation Mode	227
18.4.1	Timer RB I/O Control Register (TRBIOC) in Programmable Waveform Generation Mode	228

18.4.2	Operating Example	229
18.5	Programmable One-shot Generation Mode	230
18.5.1	Timer RB I/O Control Register (TRBIOC) in Programmable One-Shot Generation Mode	231
18.5.2	Operating Example	232
18.5.3	One-Shot Trigger Selection	233
18.6	Programmable Wait One-Shot Generation Mode	234
18.6.1	Timer RB I/O Control Register (TRBIOC) in Programmable Wait One-Shot Generation Mode ...	235
18.6.2	Operating Example	236
18.7	Notes on Timer RB	237
18.7.1	Timer Mode	237
18.7.2	Programmable Waveform Generation Mode	237
18.7.3	Programmable One-shot Generation Mode	238
18.7.4	Programmable Wait One-shot Generation Mode	238
19.	Timer RC	239
19.1	Overview	239
19.2	Registers	241
19.2.1	Module Standby Control Register (MSTCR)	242
19.2.2	Timer RC Mode Register (TRCMR)	242
19.2.3	Timer RC Control Register 1 (TRCCR1)	243
19.2.4	Timer RC Interrupt Enable Register (TRCIER)	243
19.2.5	Timer RC Status Register (TRCSR)	244
19.2.6	Timer RC I/O Control Register 0 (TRCIOR0)	245
19.2.7	Timer RC I/O Control Register 1 (TRCIOR1)	245
19.2.8	Timer RC Counter (TRC)	246
19.2.9	Timer RC General Registers A, B, C, and D (TRCGRA, TRCGRB, TRCGRC, TRCGRD)	246
19.2.10	Timer RC Control Register 2 (TRCCR2)	247
19.2.11	Timer RC Digital Filter Function Select Register (TRCDF)	247
19.2.12	Timer RC Output Master Enable Register (TRCOER)	248
19.2.13	Timer RC Trigger Control Register (TRCADCR)	248
19.2.14	Timer RB/RC Pin Select Register (TRBRCR)	249
19.2.15	Timer RC Pin Select Register 0 (TRCPSR0)	250
19.2.16	Timer RC Pin Select Register 1 (TRCPSR1)	251
19.3	Common Items for Multiple Modes	252
19.3.1	Count Source	252
19.3.2	Buffer Operation	253
19.3.3	Digital Filter	255
19.3.4	Forced Cutoff of Pulse Output	256
19.4	Timer Mode (Input Capture Function)	258
19.4.1	Timer RC I/O Control Register 0 (TRCIOR0) for Input Capture Function	260
19.4.2	Timer RC I/O Control Register 1 (TRCIOR1) for Input Capture Function	261
19.4.3	Operating Example	262
19.5	Timer Mode (Output Compare Function)	263
19.5.1	Timer RC Control Register 1 (TRCCR1) for Output Compare Function	265
19.5.2	Timer RC I/O Control Register 0 (TRCIOR0) for Output Compare Function	266
19.5.3	Timer RC I/O Control Register 1 (TRCIOR1) for Output Compare Function	267
19.5.4	Timer RC Control Register 2 (TRCCR2) for Output Compare Function	268
19.5.5	Operating Example	269
19.5.6	Changing Output Pins in Registers TRCGRC and TRCGRD	270

19.6	PWM Mode	272
19.6.1	Timer RC Control Register 1 (TRCCR1) in PWM Mode	274
19.6.2	Timer RC Control Register 2 (TRCCR2) in PWM Mode	275
19.6.3	Operating Example	276
19.7	PWM2 Mode	278
19.7.1	Timer RC Control Register 1 (TRCCR1) in PWM2 Mode	280
19.7.2	Timer RC Control Register 2 (TRCCR2) in PWM2 Mode	281
19.7.3	Timer RC Digital Filter Function Select Register (TRCDF) in PWM2 Mode	282
19.7.4	Operating Example	283
19.8	Timer RC Interrupt	286
19.9	Notes on Timer RC	287
19.9.1	TRC Register	287
19.9.2	TRCSR Register	287
19.9.3	TRCCR1 Register	287
19.9.4	Count Source Switching	287
19.9.5	Input Capture Function	288
19.9.6	TRCMR Register in PWM2 Mode	288
20.	Timer RD	289
20.1	Overview	289
20.2	Common Items for Multiple Modes	291
20.2.1	Count Sources	291
20.2.2	Buffer Operation	292
20.2.3	Synchronous Operation	294
20.2.4	Pulse Output Forced Cutoff	295
20.3	Timer Mode (Input Capture Function)	297
20.3.1	Module Standby Control Register (MSTCR)	299
20.3.2	Timer RD Start Register (TRDSTR) [Timer Mode (in Input Capture Function)].....	299
20.3.3	Timer RD Mode Register (TRDMR) [Timer Mode (in Input Capture Function)].....	300
20.3.4	Timer RD PWM Mode Register (TRDPMR) [Timer Mode (in Input Capture Function)].....	300
20.3.5	Timer RD Function Control Register (TRDFCR) [Timer Mode (in Input Capture Function)].....	301
20.3.6	Timer RD Digital Filter Function Select Register i (TRDDFi) (i = 0 or 1) [Timer Mode (in Input Capture Function)].....	301
20.3.7	Timer RD Control Register i (TRDCRi) (i = 0 or 1) [Timer Mode (in Input Capture Function)].....	302
20.3.8	Timer RD I/O Control Register Ai (TRDIORAi) (i = 0 or 1) [Timer Mode (in Input Capture Function)].....	303
20.3.9	Timer RD I/O Control Register Ci (TRDIORCi) (i = 0 or 1) [Timer Mode (in Input Capture Function)].....	304
20.3.10	Timer RD Status Register i (TRDSRi) (i = 0 or 1) [Timer Mode (in Input Capture Function)].....	305
20.3.11	Timer RD Interrupt Enable Register i (TRDIERi) (i = 0 or 1) [Timer Mode (in Input Capture Function)].....	306
20.3.12	Timer RD Counter i (TRDi) (i = 0 or 1) [Timer Mode (in Input Capture Function)].....	306
20.3.13	Timer RD General Registers Ai, Bi, Ci, and Di (TRDGRAi, TRDGRBi, TRDGRCi, TRDGRDi) (i = 0 or 1) [Timer Mode (in Input Capture Function)]	307

20.3.14	Timer RD Pin Select Register 0 (TRDPSR0)	308
20.3.15	Timer RD Pin Select Register 1 (TRDPSR1)	308
20.3.16	Operating Example	309
20.3.17	Digital Filter	310
20.4	Timer Mode (Output Compare Function)	311
20.4.1	Module Standby Control Register (MSTCR)	313
20.4.2	Timer RD Trigger Control Register (TRDADCR)	314
20.4.3	Timer RD Start Register (TRDSTR) [Timer Mode (in Output Compare Function)]	315
20.4.4	Timer RD Mode Register (TRDMR) [Timer Mode (in Output Compare Function)]	316
20.4.5	Timer RD PWM Mode Register (TRDPMR) [Timer Mode (in Output Compare Function)]	317
20.4.6	Timer RD Function Control Register (TRDFCR) [Timer Mode (in Output Compare Function)]	317
20.4.7	Timer RD Output Master Enable Register 1 (TRDOER1) [Timer Mode (in Output Compare Function)]	318
20.4.8	Timer RD Output Master Enable Register 2 (TRDOER2) [Timer Mode (in Output Compare Function)]	318
20.4.9	Timer RD Output Control Register (TRDOCR) [Timer Mode (in Output Compare Function)]	319
20.4.10	Timer RD Control Register i (TRDCRi) (i = 0 or 1) [Timer Mode (in Output Compare Function)]	320
20.4.11	Timer RD I/O Control Register Ai (TRDIORAi) (i = 0 or 1) [Timer Mode (in Output Compare Function)]	321
20.4.12	Timer RD I/O Control Register Ci (TRDIORCi) (i = 0 or 1) [Timer Mode (in Output Compare Function)]	322
20.4.13	Timer RD Status Register i (TRDSRi) (i = 0 or 1) [Timer Mode (in Output Compare Function)]	323
20.4.14	Timer RD Interrupt Enable Register i (TRDIERi) (i = 0 or 1) [Timer Mode (in Output Compare Function)]	324
20.4.15	Timer RD Counter i (TRDi) (i = 0 or 1) [Timer Mode (in Output Compare Function)]	324
20.4.16	Timer RD General Registers Ai, Bi, Ci, and Di (TRDGRAi, TRDGRBi, TRDGRCi, TRDGRDi) (i = 0 or 1) [Timer Mode (in Output Compare Function)]	325
20.4.17	Timer RD Pin Select Register 0 (TRDPSR0)	326
20.4.18	Timer RD Pin Select Register 1 (TRDPSR1)	326
20.4.19	Operating Example	327
20.4.20	Changing Output Pins in Registers TRDGRCi (i = 0 or 1) and TRDGRDi	328
20.4.21	A/D Trigger Generation	330
20.5	PWM Mode	331
20.5.1	Module Standby Control Register (MSTCR)	333
20.5.2	Timer RD Trigger Control Register (TRDADCR)	334
20.5.3	Timer RD Start Register (TRDSTR) in PWM Mode	335
20.5.4	Timer RD Mode Register (TRDMR) in PWM Mode	335
20.5.5	Timer RD PWM Mode Register (TRDPMR) in PWM Mode	336
20.5.6	Timer RD Function Control Register (TRDFCR) in PWM Mode	336
20.5.7	Timer RD Output Master Enable Register 1 (TRDOER1) in PWM Mode	337
20.5.8	Timer RD Output Master Enable Register 2 (TRDOER2) in PWM Mode	337
20.5.9	Timer RD Output Control Register (TRDOCR) in PWM Mode	338
20.5.10	Timer RD Control Register i (TRDCRi) (i = 0 or 1) in PWM Mode	338

20.5.11	Timer RD Status Register i (TRDSRi) (i = 0 or 1) in PWM Mode	339
20.5.12	Timer RD Interrupt Enable Register i (TRDIERi) (i = 0 or 1) in PWM Mode	340
20.5.13	Timer RD PWM Mode Output Level Control Register i (TRDPOCRi) (i = 0 or 1) in PWM Mode	340
20.5.14	Timer RD Counter i (TRDi) (i = 0 or 1) in PWM Mode	341
20.5.15	Timer RD General Registers Ai, Bi, Ci, and Di (TRDGRAi, TRDGRBi, TRDGRCi, TRDGRDi) (i = 0 or 1) in PWM Mode	341
20.5.16	Timer RD Pin Select Register 0 (TRDPSR0)	342
20.5.17	Timer RD Pin Select Register 1 (TRDPSR1)	342
20.5.18	Operating Example	343
20.5.19	A/D Trigger Generation	345
20.6	Reset Synchronous PWM Mode	346
20.6.1	Module Standby Control Register (MSTCR)	348
20.6.2	Timer RD Trigger Control Register (TRDADCR)	349
20.6.3	Timer RD Start Register (TRDSTR) in Reset Synchronous PWM Mode	350
20.6.4	Timer RD Mode Register (TRDMR) in Reset Synchronous PWM Mode	350
20.6.5	Timer RD Function Control Register (TRDFCR) in Reset Synchronous PWM Mode	351
20.6.6	Timer RD Output Master Enable Register 1 (TRDOER1) in Reset Synchronous PWM Mode	352
20.6.7	Timer RD Output Master Enable Register 2 (TRDOER2) in Reset Synchronous PWM Mode	352
20.6.8	Timer RD Control Register 0 (TRDCR0) in Reset Synchronous PWM Mode	353
20.6.9	Timer RD Status Register i (TRDSRi) (i = 0 or 1) in Reset Synchronous PWM Mode	354
20.6.10	Timer RD Interrupt Enable Register i (TRDIERi) (i = 0 or 1) in Reset Synchronous PWM Mode	355
20.6.11	Timer RD Counter 0 (TRD0) in Reset Synchronous PWM Mode	355
20.6.12	Timer RD General Registers Ai, Bi, Ci, and Di (TRDGRAi, TRDGRBi, TRDGRCi, TRDGRDi) (i = 0 or 1) in Reset Synchronous PWM Mode	356
20.6.13	Timer RD Pin Select Register 0 (TRDPSR0)	357
20.6.14	Timer RD Pin Select Register 1 (TRDPSR1)	357
20.6.15	Operating Example	358
20.6.16	A/D Trigger Generation	359
20.7	Complementary PWM Mode	360
20.7.1	Module Standby Control Register (MSTCR)	362
20.7.2	Timer RD Trigger Control Register (TRDADCR) in Complementary PWM Mode	363
20.7.3	Timer RD Start Register (TRDSTR) in Complementary PWM Mode	364
20.7.4	Timer RD Mode Register (TRDMR) in Complementary PWM Mode	364
20.7.5	Timer RD Function Control Register (TRDFCR) in Complementary PWM Mode	365
20.7.6	Timer RD Output Master Enable Register 1 (TRDOER1) in Complementary PWM Mode	366
20.7.7	Timer RD Output Master Enable Register 2 (TRDOER2) in Complementary PWM Mode	366
20.7.8	Timer RD Control Register i (TRDCRi) (i = 0 or 1) in Complementary PWM Mode	367
20.7.9	Timer RD Status Register i (TRDSRi) (i = 0 or 1) in Complementary PWM Mode	368
20.7.10	Timer RD Interrupt Enable Register i (TRDIERi) (i = 0 or 1) in Complementary PWM Mode	369
20.7.11	Timer RD Counter 0 (TRD0) in Complementary PWM Mode	369
20.7.12	Timer RD Counter 1 (TRD1) in Complementary PWM Mode	370
20.7.13	Timer RD General Registers Ai, Bi, C1, and Di (TRDGRAi, TRDGRBi, TRDGRC1, TRDGRDi) (i = 0 or 1) in Complementary PWM Mode	370
20.7.14	Timer RD Pin Select Register 0 (TRDPSR0)	372
20.7.15	Timer RD Pin Select Register 1 (TRDPSR1)	372
20.7.16	Operating Example	373
20.7.17	Transfer Timing from Buffer Register	375
20.7.18	A/D Trigger Generation	375

20.8	PWM3 Mode	376
20.8.1	Module Standby Control Register (MSTCR)	378
20.8.2	Timer RD Trigger Control Register (TRDADCR)	379
20.8.3	Timer RD Start Register (TRDSTR) in PWM3 Mode	380
20.8.4	Timer RD Mode Register (TRDMR) in PWM3 Mode	380
20.8.5	Timer RD Function Control Register (TRDFCR) in PWM3 Mode	381
20.8.6	Timer RD Output Master Enable Register 1 (TRDOER1) in PWM3 Mode	382
20.8.7	Timer RD Output Master Enable Register 2 (TRDOER2) in PWM3 Mode	382
20.8.8	Timer RD Output Control Register (TRDOCR) in PWM3 Mode	383
20.8.9	Timer RD Control Register 0 (TRDCR0) in PWM3 Mode	384
20.8.10	Timer RD Status Register i (TRDSRi) (i = 0 or 1) in PWM3 Mode	385
20.8.11	Timer RD Interrupt Enable Register i (TRDIERi) (i = 0 or 1) in PWM3 Mode	386
20.8.12	Timer RD Counter 0 (TRD0) in PWM3 Mode	386
20.8.13	Timer RD General Registers Ai, Bi, Ci, and Di (TRDGRAi, TRDGRBi, TRDGRCi, TRDGRDi) (i = 0 or 1) in PWM3 Mode	387
20.8.14	Timer RD Pin Select Register 0 (TRDPSR0)	389
20.8.15	Timer RD Pin Select Register 1 (TRDPSR1)	389
20.8.16	Operating Example	390
20.8.17	A/D Trigger Generation	391
20.9	Timer RD Interrupt	392
20.10	Notes on Timer RD	393
20.10.1	TRDSTR Register	393
20.10.2	TRDi Register (i = 0 or 1)	393
20.10.3	TRDSRi Register (i = 0 or 1)	393
20.10.4	TRDCRi Register (i = 0 or 1)	393
20.10.5	Count Source Switch	394
20.10.6	Input Capture Function	394
20.10.7	Reset Synchronous PWM Mode	394
20.10.8	Complementary PWM Mode	395
20.10.9	Count Source fOCO40M	398
21.	Serial Interface (UART0)	399
21.1	Overview	399
21.2	Registers	401
21.2.1	UART0 Transmit/Receive Mode Register (UOMR)	401
21.2.2	UART0 Bit Rate Register (U0BRG)	401
21.2.3	UART0 Transmit Buffer Register (U0TB)	402
21.2.4	UART0 Transmit/Receive Control Register 0 (U0C0)	403
21.2.5	UART0 Transmit/Receive Control Register 1 (U0C1)	403
21.2.6	UART0 Receive Buffer Register (U0RB)	404
21.2.7	UART0 Pin Select Register (U0SR)	405
21.3	Clock Synchronous Serial I/O Mode	406
21.3.1	Measure for Dealing with Communication Errors	410
21.3.2	Polarity Select Function	411
21.3.3	LSB First/MSB First Select Function	411
21.3.4	Continuous Receive Mode	412
21.4	Clock Asynchronous Serial I/O (UART) Mode	413
21.4.1	Bit Rate	418
21.4.2	Measure for Dealing with Communication Errors	419

21.5	Notes on Serial Interface (UART0)	420
22.	Serial Interface (UART2)	421
22.1	Overview	421
22.2	Registers	423
22.2.1	UART2 Transmit/Receive Mode Register (U2MR)	423
22.2.2	UART2 Bit Rate Register (U2BRG)	423
22.2.3	UART2 Transmit Buffer Register (U2TB)	424
22.2.4	UART2 Transmit/Receive Control Register 0 (U2C0)	425
22.2.5	UART2 Transmit/Receive Control Register 1 (U2C1)	426
22.2.6	UART2 Receive Buffer Register (U2RB)	427
22.2.7	UART2 Digital Filter Function Select Register (URXDF)	428
22.2.8	UART2 Special Mode Register 5 (U2SMR5)	428
22.2.9	UART2 Special Mode Register 4 (U2SMR4)	429
22.2.10	UART2 Special Mode Register 3 (U2SMR3)	429
22.2.11	UART2 Special Mode Register 2 (U2SMR2)	430
22.2.12	UART2 Special Mode Register (U2SMR)	430
22.2.13	UART2 Pin Select Register 0 (U2SR0)	431
22.2.14	UART2 Pin Select Register 1 (U2SR1)	431
22.3	Clock Synchronous Serial I/O Mode	432
22.3.1	Measure for Dealing with Communication Errors	436
22.3.2	CLK Polarity Select Function	436
22.3.3	LSB First/MSB First Select Function	437
22.3.4	Continuous Receive Mode	437
22.3.5	Serial Data Logic Switching Function	438
22.3.6	CTS/RTS Function	438
22.4	Clock Asynchronous Serial I/O (UART) Mode	439
22.4.1	Bit Rate	443
22.4.2	Measure for Dealing with Communication Errors	444
22.4.3	LSB First/MSB First Select Function	444
22.4.4	Serial Data Logic Switching Function	445
22.4.5	TXD and RXD I/O Polarity Inverse Function	445
22.4.6	$\overline{\text{CTS}}/\overline{\text{RTS}}$ Function	446
22.4.7	RXD2 Digital Filter Select Function	446
22.5	Special Mode 1 (I ² C Mode)	447
22.5.1	Detection of Start and Stop Conditions	453
22.5.2	Output of Start and Stop Conditions	454
22.5.3	Transfer Clock	455
22.5.4	SDA Output	455
22.5.5	SDA Input	455
22.5.6	ACK and NACK	455
22.5.7	Initialization of Transmission/Reception	456
22.6	Special Mode 3 (IE mode)	457
22.7	Multiprocessor Communication Function	459
22.7.1	Multiprocessor Transmission	462
22.7.2	Multiprocessor Reception	463
22.7.3	RXD2 Digital Filter Select Function	465
22.8	Notes on Serial Interface (UART2)	466
22.8.1	Clock Synchronous Serial I/O Mode	466

22.8.2	Special Mode 1 (I ² C Mode)	467
22.8.3	UART2 Bit Rate Register (U2BRG)	467
22.8.4	U2TB register	467
23.	Synchronous Serial Communication Unit (SSU)	468
23.1	Overview	468
23.2	Registers	470
23.2.1	Module Standby Control Register (MSTCR)	470
23.2.2	SSU Pin Select Register (SSUICSR)	471
23.2.3	SS Bit Counter Register (SSBR)	472
23.2.4	SS Transmit Data Register (SSTDR)	472
23.2.5	SS Receive Data Register (SSRDR)	473
23.2.6	SS Control Register H (SSCRH)	473
23.2.7	SS Control Register L (SSCRL)	474
23.2.8	SS Mode Register (SSMR)	475
23.2.9	SS Enable Register (SSER)	476
23.2.10	SS Status Register (SSSR)	477
23.2.11	SS Mode Register 2 (SSMR2)	478
23.3	Common Items for Multiple Modes	479
23.3.1	Transfer Clock	479
23.3.2	SS Shift Register (SSTRSR)	481
23.3.3	Interrupt Requests	482
23.3.4	Communication Modes and Pin Functions	483
23.4	Clock Synchronous Communication Mode	484
23.4.1	Initialization in Clock Synchronous Communication Mode	484
23.4.2	Data Transmission	485
23.4.3	Data Reception	487
23.5	Operation in 4-Wire Bus Communication Mode	491
23.5.1	Initialization in 4-Wire Bus Communication Mode	492
23.5.2	Data Transmission	493
23.5.3	Data Reception	495
23.5.4	SCS Pin Control and Arbitration	497
24.	Hardware LIN	498
24.1	Overview	498
24.2	Input/Output Pins	499
24.3	Registers	500
24.3.1	LIN Control Register 2 (LINCR2)	500
24.3.2	LIN Control Register (LINCR)	501
24.3.3	LIN Status Register (LINST)	501
24.4	Function Description	502
24.4.1	Master Mode	502
24.4.2	Slave Mode	505
24.4.3	Bus Collision Detection Function	509
24.4.4	Hardware LIN End Processing	510
24.5	Interrupt Requests	511
24.6	Notes on Hardware LIN	512

25.	A/D Converter	513
25.1	Overview	513
25.2	Registers	515
25.2.1	On-Chip Reference Voltage Control Register (OCVREFCR)	515
25.2.2	A/D Register i (ADi) (i = 0 to 7)	516
25.2.3	A/D Mode Register (ADMOD)	517
25.2.4	A/D Input Select Register (ADINSEL)	518
25.2.5	A/D Control Register 0 (ADCON0)	519
25.2.6	A/D Control Register 1 (ADCON1)	520
25.3	Common Items for Multiple Modes	521
25.3.1	Input/Output Pins	521
25.3.2	A/D Conversion Cycles	521
25.3.3	A/D Conversion Start Condition	523
25.3.4	A/D Conversion Result	525
25.3.5	Low Current Consumption Function	525
25.3.6	On-Chip Reference Voltage (OCVREF)	525
25.3.7	A/D Open-Circuit Detection Assist Function	525
25.4	One-Shot Mode	527
25.5	Repeat Mode 0	528
25.6	Repeat Mode 1	529
25.7	Single Sweep Mode	531
25.8	Repeat Sweep Mode	533
25.9	Output Impedance of Sensor under A/D Conversion	535
25.10	Notes on A/D Converter	536
26.	D/A Converter	537
26.1	Overview	537
26.2	Registers	539
26.2.1	D/Ai Register (DAi) (i = 0 or 1)	539
26.2.2	D/A Control Register (DACON)	539
27.	Comparator B	540
27.1	Overview	540
27.2	Registers	542
27.2.1	Comparator B Control Register 0 (INTCMP)	542
27.2.2	External Input Enable Register 0 (INTEN)	542
27.2.3	INT Input Filter Select Register 0 (INTF)	543
27.3	Functional Description	544
27.3.1	Comparator Bi Digital Filter (i = 1 or 3)	545
27.4	Comparator B1 and Comparator B3 Interrupts	546
28.	Flash Memory	547
28.1	Overview	547
28.2	Memory Map	549
28.3	Functions to Prevent Flash Memory from being Rewritten	550
28.3.1	ID Code Check Function	550
28.3.2	ROM Code Protect Function	551
28.3.3	Option Function Select Register (OFS)	551
28.4	CPU Rewrite Mode	552

28.4.1	Flash Memory Status Register (FST)	553
28.4.2	Flash Memory Control Register 0 (FMR0)	555
28.4.3	Flash Memory Control Register 1 (FMR1) [R8C/33G Group]	558
28.4.4	Flash Memory Control Register 1 (FMR1) [R8C/33H Group]	560
28.4.5	Flash Memory Control Register 2 (FMR2) [R8C/33G Group]	561
28.4.6	Flash Memory Control Register 2 (FMR2) [R8C/33H Group]	563
28.4.7	EW0 Mode	565
28.4.8	EW1 Mode	565
28.4.9	Suspend Operation	566
28.4.10	How to Set and Exit Each Mode	567
28.4.11	BGO (BackGround Operation) Function [R8C/33G Group]	568
28.4.12	Data Protect Function	569
28.4.13	Software Commands	570
28.4.14	Full Status Check	580
28.5	Standard Serial I/O Mode	582
28.5.1	ID Code Check Function	582
28.6	Parallel I/O Mode	585
28.6.1	ROM Code Protect Function	585
28.7	Notes on Flash Memory	586
28.7.1	CPU Rewrite Mode	586
29.	Reducing Power Consumption	590
29.1	Overview	590
29.2	Key Points and Processing Methods for Reducing Power Consumption	590
29.2.1	Voltage Detection Circuit	590
29.2.2	Ports	590
29.2.3	Clocks	590
29.2.4	Wait Mode, Stop Mode	590
29.2.5	Stopping Peripheral Function Clocks	590
29.2.6	Timers	590
29.2.7	A/D Converter	590
29.2.8	Clock Synchronous Serial Interface	590
29.2.9	Reducing Internal Power Consumption Using VCA20 Bit	591
29.2.10	Stopping Flash Memory	593
29.2.11	Low-Current-Consumption Read Mode	594
30.	Electrical Characteristics	595
31.	Usage Notes	619
31.1	Notes on Clock Generation Circuit	619
31.1.1	Stop Mode	619
31.1.2	Wait Mode	619
31.1.3	Reducing Internal Power Using VCA20 Bit	620
31.1.4	Oscillation Stop Detection Function	620
31.1.5	Oscillation Circuit Constants	620
31.2	Notes on Interrupts	621
31.2.1	Reading Address 00000h	621
31.2.2	SP Setting	621
31.2.3	External Interrupt and Key Input Interrupt	621

31.2.4	Changing Interrupt Sources	622
31.2.5	Rewriting Interrupt Control Register	623
31.3	Notes on ID Code Areas	624
31.3.1	Setting Example of ID Code Areas	624
31.4	Notes on Option Function Select Area	624
31.4.1	Setting Example of Option Function Select Area	624
31.5	Notes on DTC	625
31.5.1	DTC activation source	625
31.5.2	DTCENi (i = 0 to 4, 6) Registers	625
31.5.3	Peripheral Modules	625
31.5.4	Interrupt Request	625
31.5.5	DTC Activation	625
31.5.6	DTC Chain Transfers	625
31.6	Notes on Timer RA	626
31.7	Notes on Timer RB	627
31.7.1	Timer Mode	627
31.7.2	Programmable Waveform Generation Mode	627
31.7.3	Programmable One-shot Generation Mode	628
31.7.4	Programmable Wait One-shot Generation Mode	628
31.8	Notes on Timer RC	629
31.8.1	TRC Register	629
31.8.2	TRCSR Register	629
31.8.3	TRCCR1 Register	629
31.8.4	Count Source Switching	629
31.8.5	Input Capture Function	630
31.8.6	TRCMR Register in PWM2 Mode	630
31.9	Notes on Timer RD	631
31.9.1	TRDSTR Register	631
31.9.2	TRDi Register (i = 0 or 1)	631
31.9.3	TRDSRi Register (i = 0 or 1)	631
31.9.4	TRDCRi Register (i = 0 or 1)	631
31.9.5	Count Source Switch	632
31.9.6	Input Capture Function	632
31.9.7	Reset Synchronous PWM Mode	632
31.9.8	Complementary PWM Mode	633
31.9.9	Count Source fOCO40M	636
31.10	Notes on Serial Interface (UART0)	637
31.11	Notes on Serial Interface (UART2)	638
31.11.1	Clock Synchronous Serial I/O Mode	638
31.11.2	Special Mode 1 (I ² C Mode)	639
31.11.3	UART2 Bit Rate Register (U2BRG)	639
31.11.4	U2TB register	639
31.12	Notes on Hardware LIN	639
31.13	Notes on A/D Converter	639
31.14	Notes on Flash Memory	640
31.14.1	CPU Rewrite Mode	640
31.15	Notes on Noise	644
31.15.1	Inserting a Bypass Capacitor between VCC and VSS Pins as a Countermeasure against Noise and Latch-up	644

31.15.2 Countermeasures against Noise Error of Port Control Registers	644
31.16 Note on Supply Voltage Fluctuation	644
32. Notes on On-Chip Debugger	645
33. Notes on Emulator Debugger	646
Appendix 1. Package Dimensions	647
Appendix 2. Connection Examples between Serial Programmer and On-Chip Debugging Emulator ..	648
Appendix 3. Example of Oscillation Evaluation Circuit	649
Index	650

SFR Page Reference

Address	Register	Symbol	Page
0000h			
0001h			
0002h			
0003h			
0004h	Processor Mode Register 0	PM0	32
0005h	Processor Mode Register 1	PM1	173
0006h	System Clock Control Register 0	CM0	106
0007h	System Clock Control Register 1	CM1	107
0008h	Module Standby Control Register	MSTCR	242, 299, 313, 333, 348, 362, 378, 470
0009h	System Clock Control Register 3	CM3	108
000Ah	Protect Register	PRCR	134
000Bh	Reset Source Determination Register	RSTFR	32
000Ch	Oscillation Stop Detection Register	OCD	110
000Dh	Watchdog Timer Reset Register	WDTR	173
000Eh	Watchdog Timer Start Register	WDTS	173
000Fh	Watchdog Timer Control Register	WDTC	174
0010h			
0011h			
0012h			
0013h			
0014h			
0015h	High-Speed On-Chip Oscillator Control Register 7	FRA7	110
0016h			
0017h			
0018h			
0019h			
001Ah			
001Bh			
001Ch	Count Source Protection Mode Register	CSPR	174
001Dh			
001Eh			
001Fh			
0020h			
0021h			
0022h			
0023h	High-Speed On-Chip Oscillator Control Register 0	FRA0	111
0024h	High-Speed On-Chip Oscillator Control Register 1	FRA1	111
0025h	High-Speed On-Chip Oscillator Control Register 2	FRA2	112
0026h	On-Chip Reference Voltage Control Register	OCVREFCR	515
0027h			
0028h			
0029h	High-Speed On-Chip Oscillator Control Register 4	FRA4	113
002Ah	High-Speed On-Chip Oscillator Control Register 5	FRA5	113
002Bh	High-Speed On-Chip Oscillator Control Register 6	FRA6	113
002Ch			
002Dh			
002Eh			
002Fh	High-Speed On-Chip Oscillator Control Register 3	FRA3	113
0030h	Voltage Monitor Circuit Control Register	CMPA	45
0031h	Voltage Monitor Circuit Edge Select Register	VCAC	46
0032h			
0033h	Voltage Detect Register 1	VCA1	46
0034h	Voltage Detect Register 2	VCA2	47, 114
0035h			
0036h	Voltage Detection 1 Level Select Register	VD1LS	48
0037h			
0038h	Voltage Monitor 0 Circuit Control Register	VW0C	49
0039h	Voltage Monitor 1 Circuit Control Register	VW1C	50
003Ah	Voltage Monitor 2 Circuit Control Register	VW2C	51
003Bh			
003Ch			
003Dh			
003Eh			
003Fh			

Address	Register	Symbol	Page
0040h			
0041h	Flash Memory Ready Interrupt Control Register	FMRDYIC	141
0042h			
0043h			
0044h			
0045h			
0046h			
0047h	Timer RC Interrupt Control Register	TRCIC	141
0048h	Timer RD0 Interrupt Control Register	TRD0IC	141
0049h	Timer RD1 Interrupt Control Register	TRD1IC	141
004Ah			
004Bh	UART2 Transmit Interrupt Control Register	S2TIC	140
004Ch	UART2 Receive Interrupt Control Register	S2RIC	140
004Dh	Key Input Interrupt Control Register	KUPIC	140
004Eh	A/D Conversion Interrupt Control Register	ADIC	140
004Fh	SSU Interrupt Control Register	SSUIC	141
0050h			
0051h	UART0 Transmit Interrupt Control Register	S0TIC	140
0052h	UART0 Receive Interrupt Control Register	S0RIC	140
0053h			
0054h			
0055h			
0056h	Timer RA Interrupt Control Register	TRAIC	140
0057h			
0058h	Timer RB Interrupt Control Register	TRBIC	140
0059h	INT1 Interrupt Control Register	INT1IC	142
005Ah	INT3 Interrupt Control Register	INT3IC	142
005Bh			
005Ch			
005Dh	INT0 Interrupt Control Register	INT0IC	142
005Eh	UART2 Bus Collision Detection Interrupt Control Register	U2BCNIC	140
005Fh			
0060h			
0061h			
0062h			
0063h			
0064h			
0065h			
0066h			
0067h			
0068h			
0069h			
006Ah			
006Bh			
006Ch			
006Dh			
006Eh			
006Fh			
0070h			
0071h			
0072h	Voltage Monitor 1 Interrupt Control Register	VCMP1IC	140
0073h	Voltage Monitor 2 Interrupt Control Register	VCMP2IC	140
0074h			
0075h			
0076h			
0077h			
0078h			
0079h			
007Ah			
007Bh			
007Ch			
007Dh			
007Eh			
007Fh			

Note:

1. The blank regions are reserved. Do not access locations in these regions.

Address	Register	Symbol	Page
0080h	DTC Activation Control Register	DTCTL	185
0081h			
0082h			
0083h			
0084h			
0085h			
0086h			
0087h			
0088h	DTC Activation Enable Register 0	DTCEN0	184
0089h	DTC Activation Enable Register 1	DTCEN1	184
008Ah	DTC Activation Enable Register 2	DTCEN2	184
008Bh	DTC Activation Enable Register 3	DTCEN3	184
008Ch	DTC Activation Enable Register 4	DTCEN4	184
008Dh			
008Eh	DTC Activation Enable Register 6	DTCEN6	184
008Fh			
0090h			
0091h			
0092h			
0093h			
0094h			
0095h			
0096h			
0097h			
0098h			
0099h			
009Ah			
009Bh			
009Ch			
009Dh			
009Eh			
009Fh			
00A0h	UART0 Transmit/Receive Mode Register	U0MR	401
00A1h	UART0 Bit Rate Register	U0BRG	401
00A2h	UART0 Transmit Buffer Register	U0TB	402
00A3h			
00A4h	UART0 Transmit/Receive Control Register 0	U0C0	403
00A5h	UART0 Transmit/Receive Control Register 1	U0C1	403
00A6h	UART0 Receive Buffer Register	U0RB	404
00A7h			
00A8h	UART2 Transmit/Receive Mode Register	U2MR	423
00A9h	UART2 Bit Rate Register	U2BRG	423
00AAh	UART2 Transmit Buffer Register	U2TB	424
00ABh			
00ACh	UART2 Transmit/Receive Control Register 0	U2C0	425
00ADh	UART2 Transmit/Receive Control Register 1	U2C1	426
00AEh	UART2 Receive Buffer Register	U2RB	427
00AFh			
00B0h	UART2 Digital Filter Function Select Register	URXDF	428
00B1h			
00B2h			
00B3h			
00B4h			
00B5h			
00B6h			
00B7h			
00B8h			
00B9h			
00BAh			
00BBh	UART2 Special Mode Register 5	U2SMR5	428
00BCh	UART2 Special Mode Register 4	U2SMR4	429
00BDh	UART2 Special Mode Register 3	U2SMR3	429
00BEh	UART2 Special Mode Register 2	U2SMR2	430
00BFh	UART2 Special Mode Register	U2SMR	430

Address	Register	Symbol	Page
00C0h	A/D Register 0	AD0	516
00C1h			
00C2h	A/D Register 1	AD1	516
00C3h			
00C4h	A/D Register 2	AD2	516
00C5h			
00C6h	A/D Register 3	AD3	516
00C7h			
00C8h	A/D Register 4	AD4	516
00C9h			
00CAh	A/D Register 5	AD5	516
00CBh			
00CCh	A/D Register 6	AD6	516
00CDh			
00CEh	A/D Register 7	AD7	516
00CFh			
00D0h			
00D1h			
00D2h			
00D3h			
00D4h	A/D Mode Register	ADMOD	517
00D5h	A/D Input Select Register	ADINSEL	518
00D6h	A/D Control Register 0	ADCON0	519
00D7h	A/D Control Register 1	ADCON1	520
00D8h	D/A0 Register	DA0	539
00D9h	D/A1 Register	DA1	539
00DAh			
00DBh			
00DCh	D/A Control Register	DACON	539
00DDh			
00DEh			
00DFh			
00E0h	Port P0 Register	P0	72
00E1h	Port P1 Register	P1	72
00E2h	Port P0 Direction Register	PD0	71
00E3h	Port P1 Direction Register	PD1	71
00E4h			
00E5h	Port P3 Register	P3	72
00E6h			
00E7h	Port P3 Direction Register	PD3	71
00E8h	Port P4 Register	P4	72
00E9h	Port P5 Register	P5	72
00EAh	Port P4 Direction Register	PD4	71
00EBh	Port P5 Direction Register	PD5	71
00ECh			
00EDh			
00EEh			
00EFh			
00F0h			
00F1h			
00F2h			
00F3h			
00F4h			
00F5h			
00F6h			
00F7h			
00F8h			
00F9h			
00FAh			
00FBh			
00FCh			
00FDh			
00FEh			
00FFh			

Note:

1. The blank regions are reserved. Do not access locations in these regions.

Address	Register	Symbol	Page
0100h	Timer RA Control Register	TRACR	203
0101h	Timer RA I/O Control Register	TRAIOC	203, 206, 209, 211, 213, 216
0102h	Timer RA Mode Register	TRAMR	204
0103h	Timer RA Prescaler Register	TRAPRE	204
0104h	Timer RA Register	TRA	205
0105h	LIN Control Register 2	LINCR2	500
0106h	LIN Control Register	LINCR	501
0107h	LIN Status Register	LINST	501
0108h	Timer RB Control Register	TRBCR	220
0109h	Timer RB One-Shot Control Register	TRBOCR	220
010Ah	Timer RB I/O Control Register	TRBIOC	221, 224, 228, 231, 235
010Bh	Timer RB Mode Register	TRBMR	221
010Ch	Timer RB Prescaler Register	TRBPRE	222
010Dh	Timer RB Secondary Register	TRBSC	222
010Eh	Timer RB Primary Register	TRBPR	223
010Fh			
0110h			
0111h			
0112h			
0113h			
0114h			
0115h			
0116h			
0117h			
0118h			
0119h			
011Ah			
011Bh			
011Ch			
011Dh			
011Eh			
011Fh			
0120h	Timer RC Mode Register	TRCMR	242
0121h	Timer RC Control Register 1	TRCCR1	243, 265, 274, 280
0122h	Timer RC Interrupt Enable Register	TRCIER	243
0123h	Timer RC Status Register	TRCSR	244
0124h	Timer RC I/O Control Register 0	TRCIOR0	245, 260, 266
0125h	Timer RC I/O Control Register 1	TRCIOR1	245, 261, 267
0126h	Timer RC Counter	TRC	246
0127h			
0128h	Timer RC General Register A	TRCGRA	246
0129h			
012Ah	Timer RC General Register B	TRCGRB	246
012Bh			
012Ch	Timer RC General Register C	TRCGRC	246
012Dh			
012Eh	Timer RC General Register D	TRCGRD	246
012Fh			

Note:

- The blank regions are reserved. Do not access locations in these regions.

Address	Register	Symbol	Page
0130h	Timer RC Control Register 2	TRCCR2	247, 268, 275, 281
0131h	Timer RC Digital Filter Function Select Register	TRCDF	247, 282
0132h	Timer RC Output Master Enable Register	TRCOER	248
0133h	Timer RC Trigger Control Register	TRCADCR	248
0134h			
0135h			
0136h	Timer RD Trigger Control Register	TRDADCR	314, 334, 349, 363, 379
0137h	Timer RD Start Register	TRDSTR	299, 315, 335, 350, 364, 380
0138h	Timer RD Mode Register	TRDMR	300, 316, 335, 350, 364, 380
0139h	Timer RD PWM Mode Register	TRDPMR	300, 317, 336
013Ah	Timer RD Function Control Register	TRDFCR	301, 317, 336, 351, 365, 381
013Bh	Timer RD Output Master Enable Register 1	TRDOER1	318, 337, 352, 366, 382
013Ch	Timer RD Output Master Enable Register 2	TRDOER2	318, 337, 352, 366, 382
013Dh	Timer RD Output Control Register	TRDOCR	319, 338, 383
013Eh	Timer RD Digital Filter Function Select Register 0	TRDDF0	301
013Fh	Timer RD Digital Filter Function Select Register 1	TRDDF1	301
0140h	Timer RD Control Register 0	TRDCR0	302, 320, 338, 353, 367, 384
0141h	Timer RD I/O Control Register A0	TRDIORA0	303, 321
0142h	Timer RD I/O Control Register C0	TRDIORC0	304, 322
0143h	Timer RD Status Register 0	TRDSR0	305, 323, 339, 354, 368, 385
0144h	Timer RD Interrupt Enable Register 0	TRDIER0	306, 324, 340, 355, 369, 386
0145h	Timer RD PWM Mode Output Level Control Register 0	TRDPOCR0	340
0146h	Timer RD Counter 0	TRD0	306, 324, 341, 355, 369, 386
0147h			
0148h	Timer RD General Register A0	TRDGRA0	307, 325, 341, 356, 370, 387
0149h			
014Ah	Timer RD General Register B0	TRDGRB0	307, 325, 341, 356, 370, 387
014Bh			
014Ch	Timer RD General Register C0	TRDGRC0	307, 325, 341, 356, 387
014Dh			
014Eh	Timer RD General Register D0	TRDGRD0	307, 325, 341, 356, 370, 387
014Fh			
0150h	Timer RD Control Register 1	TRDCR1	302, 320, 338, 367
0151h	Timer RD I/O Control Register A1	TRDIORA1	303, 321
0152h	Timer RD I/O Control Register C1	TRDIORC1	304, 322
0153h	Timer RD Status Register 1	TRDSR1	305, 323, 339, 354, 368, 385
0154h	Timer RD Interrupt Enable Register 1	TRDIER1	306, 324, 340, 355, 369, 386
0155h	Timer RD PWM Mode Output Level Control Register 1	TRDPOCR1	340
0156h	Timer RD Counter 1	TRD1	306, 324, 341, 370
0157h			
0158h	Timer RD General Register A1	TRDGRA1	307, 325, 341, 356, 370, 387
0159h			
015Ah	Timer RD General Register B1	TRDGRB1	307, 325, 341, 356, 370, 387
015Bh			
015Ch	Timer RD General Register C1	TRDGRC1	307, 325, 341, 356, 370, 387
015Dh			
015Eh	Timer RD General Register D1	TRDGRD1	307, 325, 341, 356, 370, 387
015Fh			

Address	Register	Symbol	Page
0160h			
0161h			
0162h			
0163h			
0164h			
0165h			
0166h			
0167h			
0168h			
0169h			
016Ah			
016Bh			
016Ch			
016Dh			
016Eh			
016Fh			
0170h			
0171h			
0172h			
0173h			
0174h			
0175h			
0176h			
0177h			
0178h			
0179h			
017Ah			
017Bh			
017Ch			
017Dh			
017Eh			
017Fh			
0180h	Timer RA Pin Select Register	TRASR	73, 205
0181h	Timer RB/RC Pin Select Register	TRBRCR	73, 223, 249
0182h	Timer RC Pin Select Register 0	TRCPSR0	74, 250
0183h	Timer RC Pin Select Register 1	TRCPSR1	75, 251
0184h	Timer RD Pin Select Register 0	TRDPSR0	76, 308, 326, 342, 357, 372, 389
0185h	Timer RD Pin Select Register 1	TRDPSR1	76, 308, 326, 342, 357, 372, 389
0186h			
0187h			
0188h	UART0 Pin Select Register	U0SR	77, 405
0189h			
018Ah	UART2 Pin Select Register 0	U2SR0	78, 431
018Bh	UART2 Pin Select Register 1	U2SR1	78, 431
018Ch	SSU Pin Select Register	SSUICSR	79, 471
018Dh			
018Eh	INT Interrupt Input Pin Select Register	INTSR	80, 150
018Fh	I/O Function Pin Select Register	PINSR	81
0190h			
0191h			
0192h			
0193h	SS Bit Counter Register	SSBR	472
0194h	SS Transmit Data Register L	SSTDR	472
0195h	SS Transmit Data Register H	SSTDRH	
0196h	SS Receive Data Register L	SSRDR	473
0197h	SS Receive Data Register H	SSRDRH	
0198h	SS Control Register H	SSCRH	473
0199h	SS Control Register L	SSCRL	474
019Ah	SS Mode Register	SSMR	475
019Bh	SS Enable Register	SSER	476
019Ch	SS Status Register	SSSR	477
019Dh	SS Mode Register 2	SSMR2	478
019Eh			
019Fh			

Address	Register	Symbol	Page
01A0h			
01A1h			
01A2h			
01A3h			
01A4h			
01A5h			
01A6h			
01A7h			
01A8h			
01A9h			
01AAh			
01ABh			
01ACh			
01ADh			
01AEh			
01AFh			
01B0h			
01B1h			
01B2h	Flash Memory Status Register	FST	553
01B3h			
01B4h	Flash Memory Control Register 0	FMR0	555
01B5h	Flash Memory Control Register 1	FMR1	558, 560
01B6h	Flash Memory Control Register 2	FMR2	561, 563
01B7h			
01B8h			
01B9h			
01BAh			
01BBh			
01BCh			
01BDh			
01BEh			
01C0h	Address Match Interrupt Register 0	RMAD0	157
01C1h			
01C2h			
01C3h	Address Match Interrupt Enable Register 0	AIER0	157
01C4h	Address Match Interrupt Register 1	RMAD1	157
01C5h			
01C6h			
01C7h	Address Match Interrupt Enable Register 1	AIER1	157
01C8h			
01C9h			
01CAh			
01CBh			
01CCh			
01CDh			
01CEh			
01CFh			
01D0h			
01D1h			
01D2h			
01D3h			
01D4h			
01D5h			
01D6h			
01D7h			
01D8h			
01D9h			
01DAh			
01DBh			
01DCh			
01DDh			
01DEh			
01DFh			

Note:

1. The blank regions are reserved. Do not access locations in these regions.

Address	Register	Symbol	Page
01E0h	Pull-Up Control Register 0	PUR0	82
01E1h	Pull-Up Control Register 1	PUR1	82
01E2h			
01E3h			
01E4h			
01E5h			
01E6h			
01E7h			
01E8h			
01E9h			
01EAh			
01EBh			
01ECh			
01EDh			
01EEh			
01EFh			
01F0h			
01F1h			
01F2h			
01F3h			
01F4h			
01F5h	Input Threshold Control Register 0	VLT0	83
01F6h	Input Threshold Control Register 1	VLT1	84
01F7h			
01F8h	Comparator B Control Register 0	INTCMP	542
01F9h			
01FAh	External Input Enable Register 0	INTEN	151, 542
01FBh			
01FCh	INT Input Filter Select Register 0	INTF	152, 543
01FDh			
01FEh	Key Input Enable Register 0	KIEN	155
01FFh			
2C00h	DTC Transfer Vector Area		
2C01h	DTC Transfer Vector Area		
2C02h			
2C03h	DTC Transfer Vector Area		
2C04h			
2C05h			
2C06h			
2C07h			
2C08h	DTC Transfer Vector Area		
2C09h	DTC Transfer Vector Area		
2C0Ah	DTC Transfer Vector Area		
2C0Bh	DTC Transfer Vector Area		
2C0Ch			
2C0Dh			
2C0Eh	DTC Transfer Vector Area		
2C0Fh	DTC Transfer Vector Area		
2C10h	DTC Transfer Vector Area		
2C11h	DTC Transfer Vector Area		
2C12h	DTC Transfer Vector Area		
2C13h	DTC Transfer Vector Area		
2C14h			
2C15h			
2C16h	DTC Transfer Vector Area		
2C17h	DTC Transfer Vector Area		
2C18h	DTC Transfer Vector Area		
2C19h	DTC Transfer Vector Area		
2C1Ah	DTC Transfer Vector Area		
2C1Bh	DTC Transfer Vector Area		
2C1Ch	DTC Transfer Vector Area		
2C1Dh	DTC Transfer Vector Area		
2C1Eh	DTC Transfer Vector Area		
2C1Fh	DTC Transfer Vector Area		

Note:
1. The blank regions are reserved. Do not access locations in these regions.

Address	Register	Symbol	Page
2C20h	DTC Transfer Vector Area		
2C21h	DTC Transfer Vector Area		
2C22h			
:			
:			
2C30h			
2C31h	DTC Transfer Vector Area		
2C32h			
2C33h	DTC Transfer Vector Area		
2C34h	DTC Transfer Vector Area		
2C35h			
2C36h			
2C37h			
2C38h			
2C39h			
2C3Ah			
2C3Bh			
2C3Ch			
2C3Dh			
2C3Eh			
2C3Fh			
2C40h	DTC Control Data 0	DTCD0	
2C41h			
2C42h			
2C43h			
2C44h			
2C45h			
2C46h			
2C47h			
2C48h	DTC Control Data 1	DTCD1	
2C49h			
2C4Ah			
2C4Bh			
2C4Ch			
2C4Dh			
2C4Eh			
2C4Fh			
2C50h	DTC Control Data 2	DTCD2	
2C51h			
2C52h			
2C53h			
2C54h			
2C55h			
2C56h			
2C57h			
2C58h	DTC Control Data 3	DTCD3	
2C59h			
2C5Ah			
2C5Bh			
2C5Ch			
2C5Dh			
2C5Eh			
2C5Fh			
2C60h	DTC Control Data 4	DTCD4	
2C61h			
2C62h			
2C63h			
2C64h			
2C65h			
2C66h			
2C67h			
2C68h	DTC Control Data 5	DTCD5	
2C69h			
2C6Ah			
2C6Bh			
2C6Ch			
2C6Dh			
2C6Eh			
2C6Fh			

Address	Register	Symbol	Page
2C70h	DTC Control Data 6	DTCD6	
2C71h			
2C72h			
2C73h			
2C74h			
2C75h			
2C76h			
2C77h			
2C78h	DTC Control Data 7	DTCD7	
2C79h			
2C7Ah			
2C7Bh			
2C7Ch			
2C7Dh			
2C7Eh			
2C7Fh			
2C80h	DTC Control Data 8	DTCD8	
2C81h			
2C82h			
2C83h			
2C84h			
2C85h			
2C86h			
2C87h			
2C88h	DTC Control Data 9	DTCD9	
2C89h			
2C8Ah			
2C8Bh			
2C8Ch			
2C8Dh			
2C8Eh			
2C8Fh			
2C90h	DTC Control Data 10	DTCD10	
2C91h			
2C92h			
2C93h			
2C94h			
2C95h			
2C96h			
2C97h			
2C98h	DTC Control Data 11	DTCD11	
2C99h			
2C9Ah			
2C9Bh			
2C9Ch			
2C9Dh			
2C9Eh			
2C9Fh			
2CA0h	DTC Control Data 12	DTCD12	
2CA1h			
2CA2h			
2CA3h			
2CA4h			
2CA5h			
2CA6h			
2CA7h			
2CA8h	DTC Control Data 13	DTCD13	
2CA9h			
2CAAh			
2CABh			
2CACH			
2CADh			
2CAEh			
2CAFh			
2CB0h	DTC Control Data 14	DTCD14	
2CB1h			
2CB2h			
2CB3h			
2CB4h			
2CB5h			
2CB6h			
2CB7h			

Address	Register	Symbol	Page
2CB8h	DTC Control Data 15	DTCD15	
2CB9h			
2CBAh			
2CBBh			
2CBCh			
2CBDh			
2CBEh			
2CBFh			
2CC0h	DTC Control Data 16	DTCD16	
2CC1h			
2CC2h			
2CC3h			
2CC4h			
2CC5h			
2CC6h			
2CC7h			
2CC8h	DTC Control Data 17	DTCD17	
2CC9h			
2CCAh			
2CCBh			
2CCCh			
2CCDh			
2CCEh			
2CCFh			
2CD0h	DTC Control Data 18	DTCD18	
2CD1h			
2CD2h			
2CD3h			
2CD4h			
2CD5h			
2CD6h			
2CD7h			
2CD8h	DTC Control Data 19	DTCD19	
2CD9h			
2CDAh			
2CDBh			
2CDCh			
2CDDh			
2CDEh			
2CDFh			
2CE0h	DTC Control Data 20	DTCD20	
2CE1h			
2CE2h			
2CE3h			
2CE4h			
2CE5h			
2CE6h			
2CE7h			
2CE8h	DTC Control Data 21	DTCD21	
2CE9h			
2CEAh			
2CEBh			
2CECh			
2CEDh			
2CEEh			
2CEFh			
2CF0h	DTC Control Data 22	DTCD22	
2CF1h			
2CF2h			
2CF3h			
2CF4h			
2CF5h			
2CF6h			
2CF7h			
2CF8h	DTC Control Data 23	DTCD23	
2CF9h			
2CFAh			
2CFBh			
2CFCh			
2CFDh			
2CFEh			
2CFFh			
2D00h			
2D01h			

Note:

- The blank regions are reserved. Do not access locations in these regions.

FFDBh	Option Function Select Register 2	OFS2	34, 169, 176
FFFFh	Option Function Select Register	OFS	33, 52, 168, 175, 551

1. Overview

1.1 Features

The R8C/33G Group, R8C/33H Group of single-chip MCUs incorporates the R8C CPU core, employing sophisticated instructions for a high level of efficiency. With 1 Mbyte of address space, and it is capable of executing instructions at high speed. In addition, the CPU core boasts a multiplier for high-speed operation processing.

Power consumption is low, and the supported operating modes allow additional power control. These MCUs are designed to maximize EMI/EMS performance.

Integration of many peripheral functions, including multifunction timer and serial interface, reduces the number of system components.

The R8C/33G Group has data flash (1 KB × 4 blocks) with the background operation (BGO) function.

1.1.1 Applications

Automobiles and others

1.1.2 Specifications

Tables 1.1 and 1.2 outline the Specifications for R8C/33G Group. Tables 1.3 and 1.4 outline the Specifications for R8C/33H Group.

Table 1.1 Specifications for R8C/33G Group (1)

Item	Function	Specification
CPU	Central processing unit	R8C CPU core <ul style="list-style-type: none"> • Number of fundamental instructions: 89 • Minimum instruction execution time: 50 ns ($f(XIN) = 20$ MHz, $VCC = 2.7$ to 5.5 V) • Multiplier: 16 bits \times 16 bits \rightarrow 32 bits • Multiply-accumulate instruction: 16 bits \times 16 bits + 32 bits \rightarrow 32 bits • Operation mode: Single-chip mode (address space: 1 Mbyte)
Memory	ROM, RAM, Data flash	Refer to Table 1.5 Product List for R8C/33G Group .
Power Supply Voltage Detection	Voltage detection circuit	<ul style="list-style-type: none"> • Power-on reset • Voltage detection 3 (detection level of voltage detection 1 selectable)
I/O Ports	Programmable I/O ports	<ul style="list-style-type: none"> • Input-only: 1 pin • CMOS I/O ports: 27, selectable pull-up resistor
Clock	Clock generation circuits	3 circuits: XIN clock oscillation circuit, High-speed on-chip oscillator (with frequency adjustment function), Low-speed on-chip oscillator <ul style="list-style-type: none"> • Oscillation stop detection: XIN clock oscillation stop detection function • Frequency divider circuit: Dividing selectable 1, 2, 4, 8, and 16 • Low power consumption modes: Standard operating mode (high-speed clock, high-speed on-chip oscillator, low-speed on-chip oscillator), wait mode, stop mode
Interrupts		<ul style="list-style-type: none"> • Number of interrupt vectors: 69 • External Interrupt: 7 (INT \times 3, Key input \times 4) • Priority levels: 7 levels
Watchdog Timer		<ul style="list-style-type: none"> • 14 bits \times 1 (with prescaler) • Reset start selectable • Low-speed on-chip oscillator for watchdog timer selectable
DTC (Data Transfer Controller)		<ul style="list-style-type: none"> • 1 channel • Activation sources: 28 • Transfer modes: 2 (normal mode, repeat mode)
Timer	Timer RA	8 bits \times 1 (with 8-bit prescaler) Timer mode (period timer), pulse output mode (output level inverted every period), event counter mode, pulse width measurement mode, pulse period measurement mode
	Timer RB	8 bits \times 1 (with 8-bit prescaler) Timer mode (period timer), programmable waveform generation mode (PWM output), programmable one-shot generation mode, programmable wait one-shot generation mode
	Timer RC	16 bits \times 1 (with 4 capture/compare registers) Timer mode (input capture function, output compare function), PWM mode (output 3 pins), PWM2 mode (PWM output pin)
	Timer RD (1)	16 bits \times 2 (with 4 capture/compare registers) Timer mode (input capture function, output compare function), PWM mode (output 6 pins), reset synchronous PWM mode (output three-phase waveforms (6 pins), sawtooth wave modulation), complementary PWM mode (output three-phase waveforms (6 pins), triangular wave modulation), PWM3 mode (PWM output 2 pins with fixed period)

Note:

1. Timer RD in these products does not support full-spec emulators. Use the on-chip debugging emulator for debugging.

Table 1.2 Specifications for R8C/33G Group (2)

Item	Function	Specification
Serial Interface	UART0	1 channel Clock synchronous serial I/O/UART
	UART2	1 channel Clock synchronous serial I/O/UART, I ² C mode (I ² C-bus), IE mode (IEBus), multiprocessor communication function
Synchronous Serial Communication Unit (SSU)		1 channel
LIN Module		Hardware LIN: 1 (timer RA, UART0)
A/D Converter		10-bit resolution x 12 channels, includes sample and hold function, with sweep mode
D/A Converter		8-bit resolution x 2 circuits
Comparator B		2 circuits
Flash Memory		<ul style="list-style-type: none"> • Programming and erasure voltage: VCC = 2.7 to 5.5 V • Programming and erasure endurance: 10,000 times (data flash) 1,000 times (program ROM) • Program security: ROM code protect, ID code check • Debug functions: On-chip debug, on-board flash rewrite function • Background operation (BGO) function
Operating Frequency/Supply Voltage		f(XIN) = 20 MHz (VCC = 2.7 to 5.5 V)
Current consumption		Typ. 7 mA (VCC = 5.0 V, f(XIN) = 20 MHz)
Operating Ambient Temperature		-40 to 85°C (J version) -80 to 125°C (K version) (1)
Package		32-pin LQFP Package code: PLQP0032GB-A (previous code: 32P6U-A)

Note:

1. Specify the K version if K version functions are to be used.

Table 1.3 Specifications for R8C/33H Group (1)

Item	Function	Specification
CPU	Central processing unit	R8C CPU core <ul style="list-style-type: none"> • Number of fundamental instructions: 89 • Minimum instruction execution time: 50 ns ($f(XIN) = 20$ MHz, $VCC = 2.7$ to 5.5 V) • Multiplier: 16 bits \times 16 bits \rightarrow 32 bits • Multiply-accumulate instruction: 16 bits \times 16 bits + 32 bits \rightarrow 32 bits • Operation mode: Single-chip mode (address space: 1 Mbyte)
Memory	ROM, RAM	Refer to Table 1.6 Product List for R8C/33H Group .
Power Supply Voltage Detection	Voltage detection circuit	<ul style="list-style-type: none"> • Power-on reset • Voltage detection 3 (detection level of voltage detection 1 selectable)
I/O Ports	Programmable I/O ports	<ul style="list-style-type: none"> • Input-only: 1 pin • CMOS I/O ports: 27, selectable pull-up resistor
Clock	Clock generation circuits	<p>3 circuits: XIN clock oscillation circuit, High-speed on-chip oscillator (with frequency adjustment function), Low-speed on-chip oscillator</p> <ul style="list-style-type: none"> • Oscillation stop detection: XIN clock oscillation stop detection function • Frequency divider circuit: Dividing selectable 1, 2, 4, 8, and 16 • Low power consumption modes: Standard operating mode (high-speed clock, high-speed on-chip oscillator, low-speed on-chip oscillator), wait mode, stop mode
Interrupts		<ul style="list-style-type: none"> • Number of interrupt vectors: 69 • External Interrupt: 7 ($INT \times 3$, Key input $\times 4$) • Priority levels: 7 levels
Watchdog Timer		<ul style="list-style-type: none"> • 14 bits \times 1 (with prescaler) • Reset start selectable • Low-speed on-chip oscillator for watchdog timer selectable
DTC (Data Transfer Controller)		<ul style="list-style-type: none"> • 1 channel • Activation sources: 28 • Transfer modes: 2 (normal mode, repeat mode)
Timer	Timer RA	<p>8 bits \times 1 (with 8-bit prescaler)</p> <p>Timer mode (period timer), pulse output mode (output level inverted every period), event counter mode, pulse width measurement mode, pulse period measurement mode</p>
	Timer RB	<p>8 bits \times 1 (with 8-bit prescaler)</p> <p>Timer mode (period timer), programmable waveform generation mode (PWM output), programmable one-shot generation mode, programmable wait one-shot generation mode</p>
	Timer RC	<p>16 bits \times 1 (with 4 capture/compare registers)</p> <p>Timer mode (input capture function, output compare function), PWM mode (output 3 pins), PWM2 mode (PWM output pin)</p>
	Timer RD (1)	<p>16 bits \times 2 (with 4 capture/compare registers)</p> <p>Timer mode (input capture function, output compare function), PWM mode (output 6 pins), reset synchronous PWM mode (output three-phase waveforms (6 pins), sawtooth wave modulation), complementary PWM mode (output three-phase waveforms (6 pins), triangular wave modulation), PWM3 mode (PWM output 2 pins with fixed period)</p>

Note:

1. Timer RD in these products does not support full-spec emulators. Use the on-chip debugging emulator for debugging.

Table 1.4 Specifications for R8C/33H Group (2)

Item	Function	Specification
Serial Interface	UART0	1 channel Clock synchronous serial I/O/UART
	UART2	1 channel Clock synchronous serial I/O/UART, I ² C mode (I ² C-bus), IE mode (IEBus), multiprocessor communication function
Synchronous Serial Communication Unit (SSU)		1 channel
LIN Module		Hardware LIN: 1 (timer RA, UART0)
A/D Converter		10-bit resolution × 12 channels, includes sample and hold function, with sweep mode
D/A Converter		8-bit resolution × 2 circuits
Comparator B		2 circuits
Flash Memory		<ul style="list-style-type: none"> • Programming and erasure voltage: VCC = 2.7 to 5.5 V • Programming and erasure endurance: 100 times (program ROM) • Program security: ROM code protect, ID code check • Debug functions: On-chip debug, on-board flash rewrite function
Operating Frequency/Supply Voltage		f(XIN) = 20 MHz (VCC = 2.7 to 5.5 V)
Current consumption		Typ. 7 mA (VCC = 5.0 V, f(XIN) = 20 MHz)
Operating Ambient Temperature		-40 to 85°C (J version) -80 to 125°C (K version) ⁽¹⁾
Package		32-pin LQFP Package code: PLQP0032GB-A (previous code: 32P6U-A)

Note:

1. Specify the K version if K version functions are to be used.

1.2 Product List

Table 1.5 lists Product List for R8C/33G Group and Figure 1.1 shows a Part Number, Memory Size, and Package of R8C/33G Group. Table 1.6 lists Product List for R8C/33H Group and Figure 1.2 shows a Part Number, Memory Size, and Package of R8C/33H Group.

Table 1.5 Product List for R8C/33G Group **Current of Jan 2014**

Part No.	ROM Capacity		RAM Capacity	Package Type	Remarks
	Program ROM	Data flash			
R5F21334GJFP	16 Kbytes	1 Kbyte × 4	1.5 Kbytes	PLQP0032GB-A	J version
R5F21336GJFP	32 Kbytes	1 Kbyte × 4	2.5 Kbytes	PLQP0032GB-A	
R5F21334GKFP	16 Kbytes	1 Kbyte × 4	1.5 Kbytes	PLQP0032GB-A	K version
R5F21336GKFP	32 Kbytes	1 Kbyte × 4	2.5 Kbytes	PLQP0032GB-A	

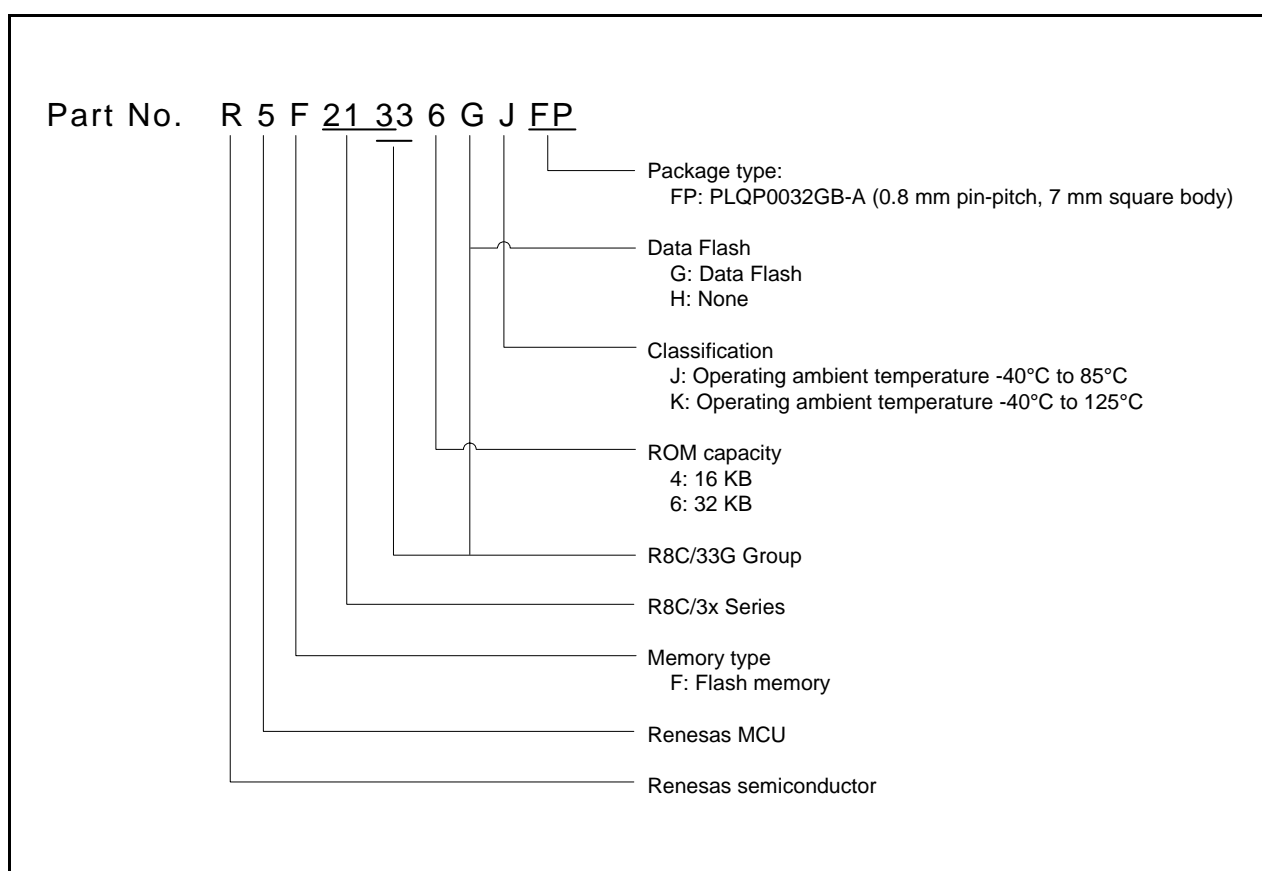

Figure 1.1 Part Number, Memory Size, and Package of R8C/33G Group

Table 1.6 Product List for R8C/33H Group **Current of Jan 2014**

Part No.	ROM Capacity		RAM Capacity	Package Type	Remarks
	Program ROM	Data flash			
R5F21334HJFP	16 Kbytes	1 Kbyte × 4	1.5 Kbytes	PLQP0032GB-A	J version
R5F21336HJFP	32 Kbytes	1 Kbyte × 4	2.5 Kbytes	PLQP0032GB-A	
R5F21334HKFP	16 Kbytes	1 Kbyte × 4	1.5 Kbytes	PLQP0032GB-A	K version
R5F21336HKFP	32 Kbytes	1 Kbyte × 4	2.5 Kbytes	PLQP0032GB-A	

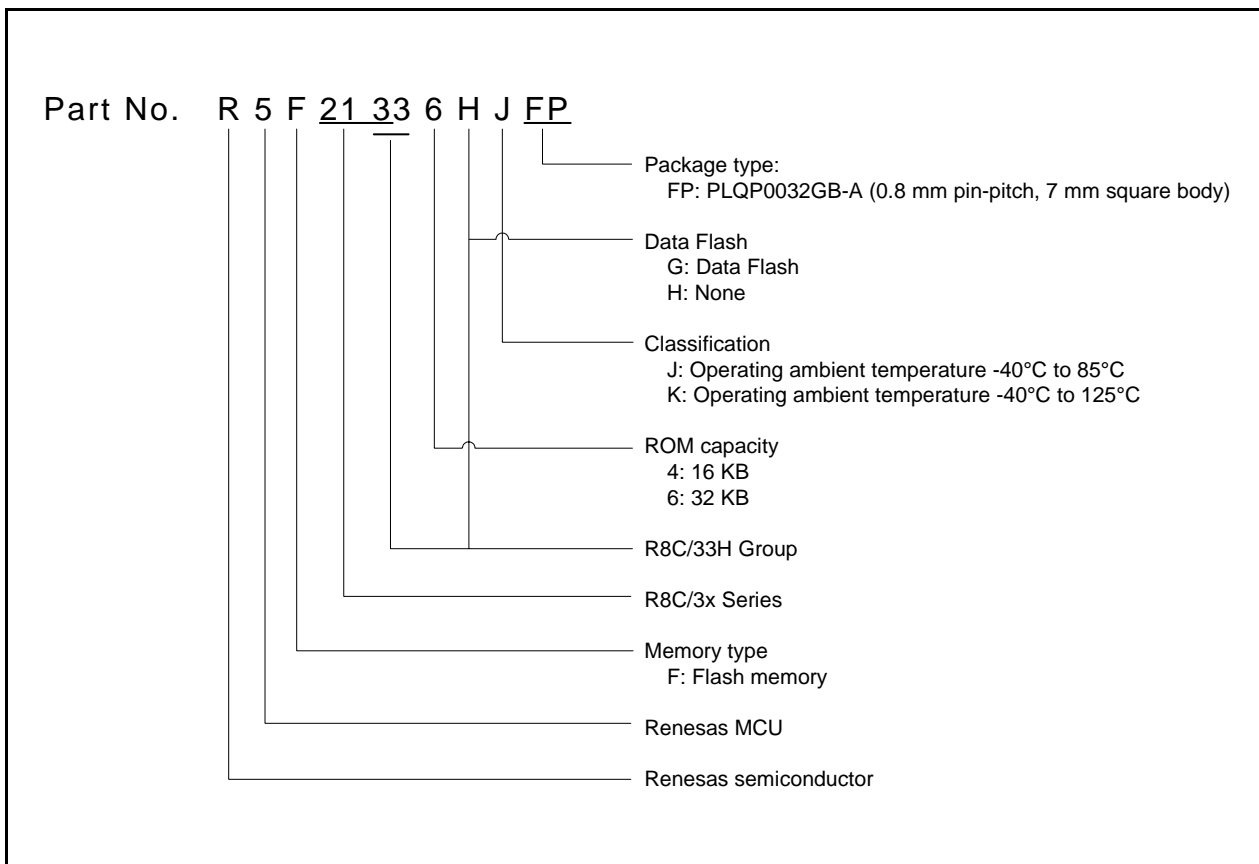

Figure 1.2 Part Number, Memory Size, and Package of R8C/33H Group

1.3 Block Diagram

Figure 1.2 shows a Block Diagram.

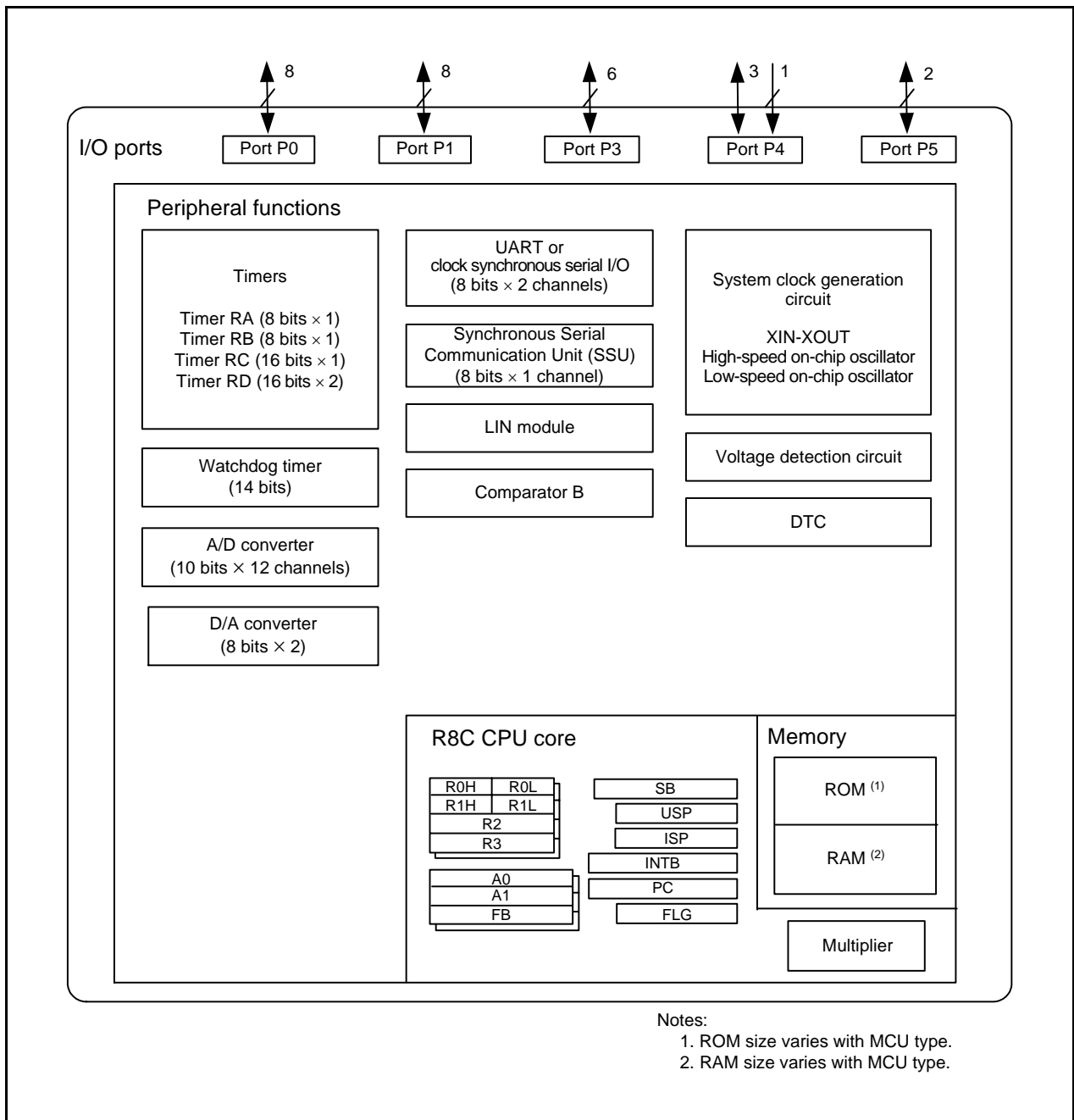

Figure 1.3 Block Diagram

1.4 Pin Assignment

Figure 1.4 shows the Pin Assignment (Top View). Table 1.7 outline the Pin Name Information by Pin Number.

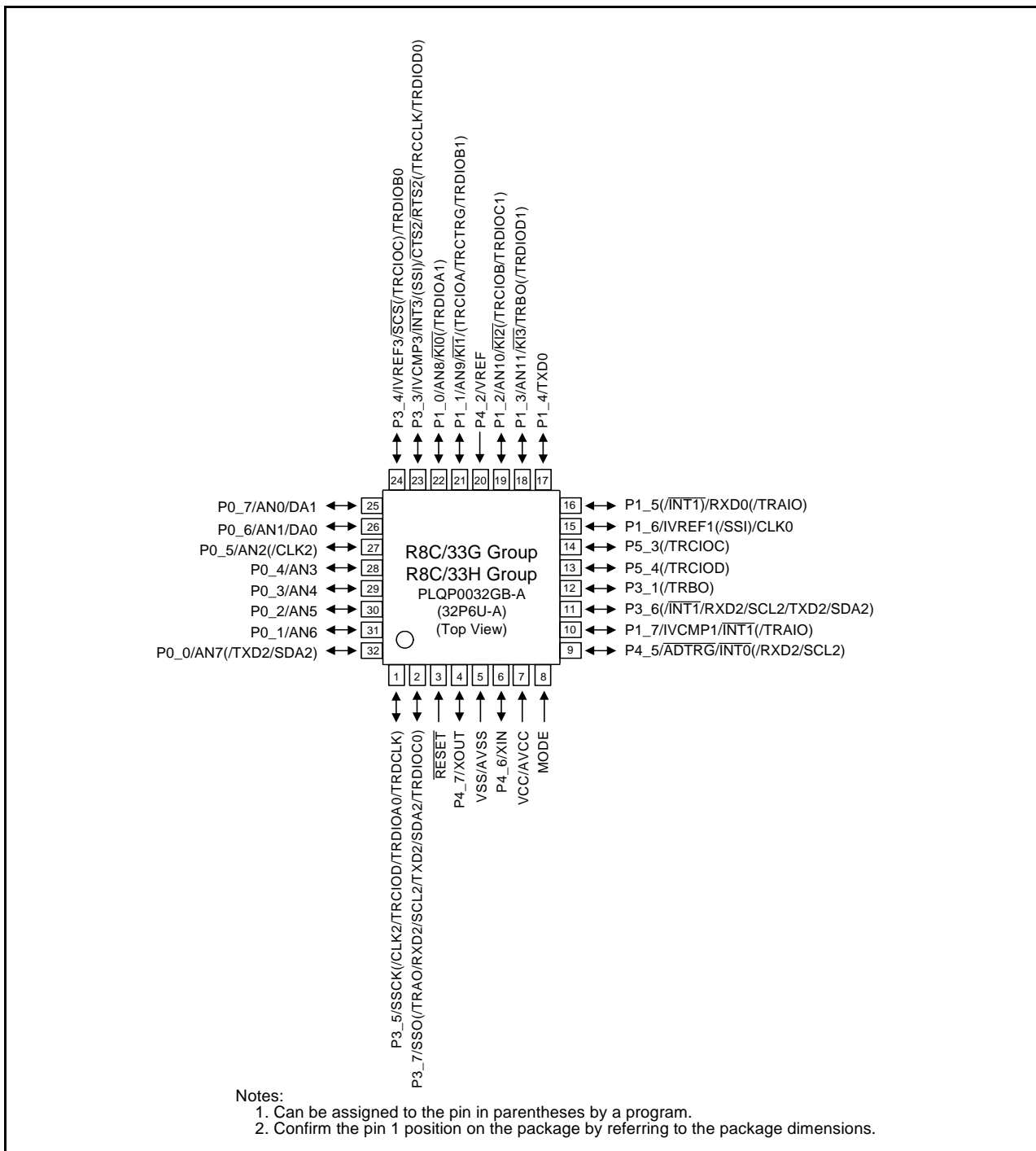

Figure 1.4 Pin Assignment (Top View)

Table 1.7 Pin Name Information by Pin Number

Pin Number	Control Pin	Port	I/O Pin Functions for Peripheral Modules				
			Interrupt	Timer	Serial Interface	SSU	A/D Converter, D/A Converter, Comparator B
1		P3_5		(TRCIOD/ TRDIOA0/ TRDCLK)	(CLK2)	SSCK	
2		P3_7		(TRAO/TRDIOC0)	(RXD2/SCL2/ TXD2/SDA2)	SSO	
3	$\overline{\text{RESET}}$						
4	XOUT	P4_7					
5	VSS/AVSS						
6	XIN	P4_6					
7	VCC/AVCC						
8	MODE						
9		P4_5	$\overline{\text{INT0}}$		(RXD2/SCL2)		$\overline{\text{ADTRG}}$
10		P1_7	$\overline{\text{INT1}}$	(TRAIO)			IVCMP1
11		P3_6	$\overline{\text{INT1}}$		(RXD2/SCL2/ TXD2/SDA2)		
12		P3_1		(TRBO)			
13		P5_4		(TRCIOD)			
14		P5_3		(TRCIOC)			
15		P1_6			CLK0	(SSI)	IVREF1
16		P1_5	$\overline{\text{INT1}}$	(TRAIO)	RXD0		
17		P1_4			TXD0		
18		P1_3	$\overline{\text{KI3}}$	TRBO/(TRDIOD1)			AN11
19		P1_2	$\overline{\text{KI2}}$	(TRCIOB/ TRDIOC1)			AN10
20		P4_2					VREF
21		P1_1	$\overline{\text{KI1}}$	(TRCIOA/ TRCTRG/ TRDIOB1)			AN9
22		P1_0	$\overline{\text{KI0}}$	(TRDIOA1)			AN8
23		P3_3	$\overline{\text{INT3}}$	(TRCCLK/ TRDIOD0)	$\overline{\text{CTS2/RTS2}}$	(SSI)	IVCMP3
24		P3_4		(TRCIOC/ TRDIOB0)		$\overline{\text{SCS}}$	IVREF3
25		P0_7					AN0/DA1
26		P0_6					AN1/DA0
27		P0_5			(CLK2)		AN2
28		P0_4					AN3
29		P0_3					AN4
30		P0_2					AN5
31		P0_1					AN6
32		P0_0			(TXD2/SDA2)		AN7

Note:

1. Can be assigned to the pin in parentheses by a program.

1.5 Pin Functions

Tables 1.8 and 1.9 list Pin Functions.

Table 1.8 Pin Functions (1)

Item	Pin Name	I/O Type	Description
Power supply input	VCC, VSS	–	Apply 2.7 V to 5.5 V to the VCC pin. Apply 0 V to the VSS pin.
Analog power supply input	AVCC, AVSS	–	Power supply for the A/D converter. Connect a capacitor between AVCC and AVSS.
Reset input	$\overline{\text{RESET}}$	I	Input “L” on this pin resets the MCU.
MODE	MODE	I	Connect this pin to VCC via a resistor.
XIN clock input	XIN	I	These pins are provided for XIN clock generation circuit I/O. Connect a ceramic resonator or a crystal oscillator between the XIN and XOUT pins ⁽¹⁾ . To use an external clock, input it to the XOUT pin and leave the XIN pin open.
XIN clock output	XOUT	I/O	
$\overline{\text{INT}}$ interrupt input	$\overline{\text{INT0}}$ to $\overline{\text{INT1}}$, $\overline{\text{INT3}}$	I	$\overline{\text{INT}}$ interrupt input pins.
Key input interrupt	$\overline{\text{KI0}}$ to $\overline{\text{KI3}}$	I	Key input interrupt input pins
Timer RA	TRAIO	I/O	Timer RA I/O pin
	TRAO	O	Timer RA output pin
Timer RB	TRBO	O	Timer RB output pin
Timer RC	TRCLK	I	External clock input pin
	TRCTR	I	External trigger input pin
	TRCIOA, TRCIOB, TRCIOC, TRCIOD	I/O	Timer RC I/O pins
Timer RD	TRDIOA0, TRDIOA1, TRDIOB0, TRDIOB1, TRDIOC0, TRDIOC1, TRDIOD0, TRDIOD1	I/O	Timer RD I/O pins
	TRDCLK	I	External clock input pin
Serial interface	CLK0, CLK2	I/O	Transfer clock I/O pins
	RXD0, RXD2	I	Serial data input pins
	TXD0, TXD2	O	Serial data output pins
	$\overline{\text{CTS2}}$	I	Transmission control input pin
	$\overline{\text{RTS2}}$	O	Reception control output pin
	SCL2	I/O	I ² C mode clock I/O pin
	SDA2	I/O	I ² C mode data I/O pin
Synchronous Serial Communication Unit (SSU)	SSI	I/O	Data I/O pin
	$\overline{\text{SCS}}$	I/O	Chip-select signal I/O pin
	SSCK	I/O	Clock I/O pin
	SSO	I/O	Data I/O pin

I: Input O: Output I/O: Input and output

Note:

1. Refer to the oscillator manufacturer for oscillation characteristics.

Table 1.9 Pin Functions (2)

Item	Pin Name	I/O Type	Description
Reference voltage input	VREF	I	Reference voltage input pin to A/D converter and D/A converter
A/D converter	AN0 to AN11	I	Analog input pins to A/D converter
	$\overline{\text{ADTRG}}$	I	A/D external trigger input pin
D/A converter	DA0, DA1	O	D/A converter output pins
Comparator B	IVCMP1, IVCMP3	I	Comparator B analog voltage input pins
	IVREF1, IVREF3	I	Comparator B reference voltage input pins
I/O port	P0_0 to P0_7, P1_0 to P1_7, P3_1, P3_3 to P3_7, P4_5 to P4_7, P5_3, P5_4	I/O	CMOS I/O ports. Each port has an I/O select direction register, allowing each pin in the port to be directed for input or output individually. Any port set to input can be set to use a pull-up resistor or not by a program.
Input port	P4_2	I	Input-only port

I: Input O: Output I/O: Input and output

2. Central Processing Unit (CPU)

Figure 2.1 shows the CPU Registers. The CPU contains 13 registers. R0, R1, R2, R3, A0, A1, and FB configure a register bank. There are two sets of register bank.

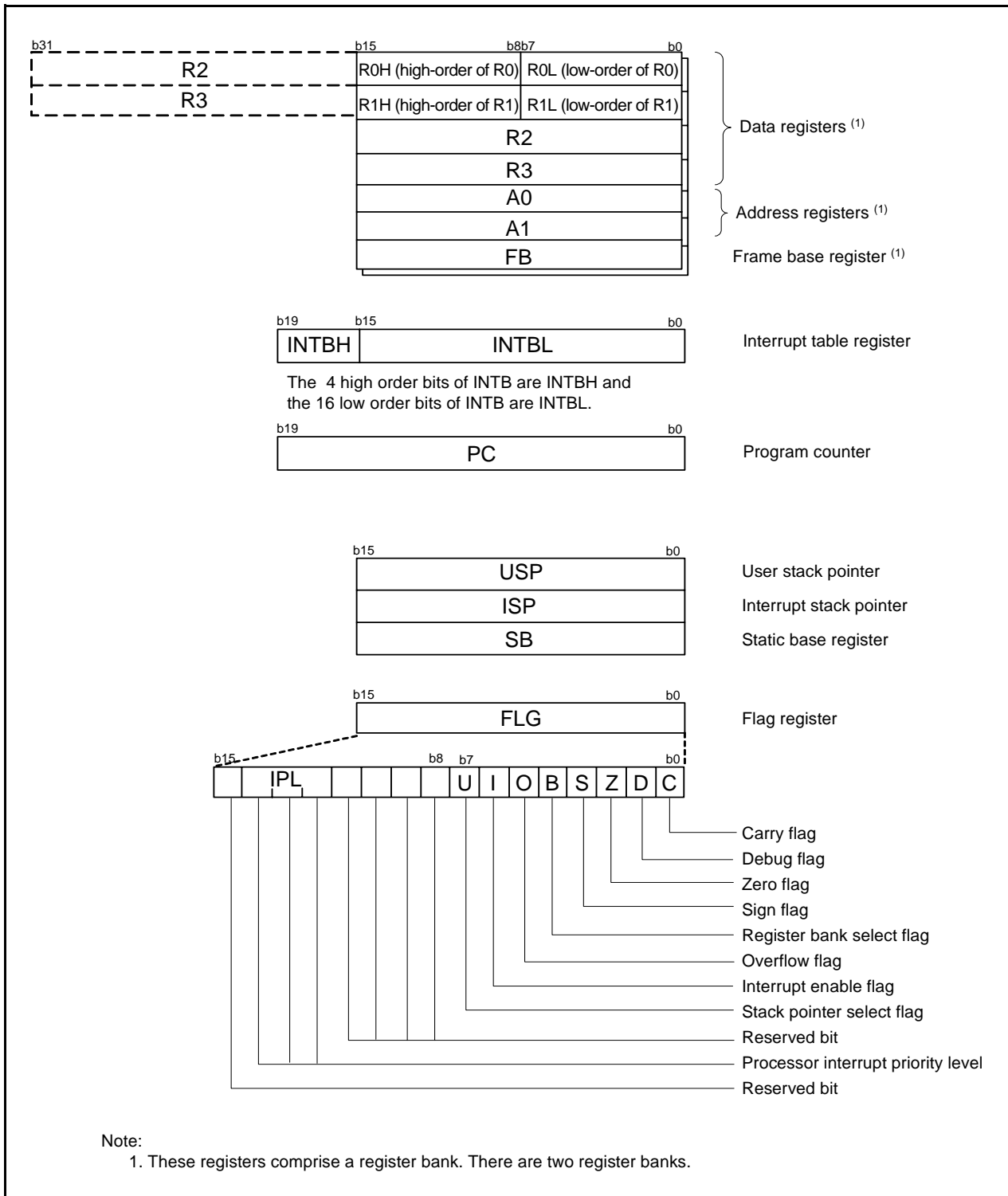

Figure 2.1 CPU Registers

2.1 Data Registers (R0, R1, R2, and R3)

R0 is a 16-bit register for transfer, arithmetic, and logic operations. The same applies to R1 to R3. R0 can be split into high-order bits (R0H) and low-order bits (R0L) to be used separately as 8-bit data registers. R1H and R1L are analogous to R0H and R0L. R2 can be combined with R0 and used as a 32-bit data register (R2R0). R3R1 is analogous to R2R0.

2.2 Address Registers (A0 and A1)

A0 is a 16-bit register for address register indirect addressing and address register relative addressing. It is also used for transfer, arithmetic, and logic operations. A1 is analogous to A0. A1 can be combined with A0 and as a 32-bit address register (A1A0).

2.3 Frame Base Register (FB)

FB is a 16-bit register for FB relative addressing.

2.4 Interrupt Table Register (INTB)

INTB is a 20-bit register that indicates the starting address of an interrupt vector table.

2.5 Program Counter (PC)

PC is 20 bits wide and indicates the address of the next instruction to be executed.

2.6 User Stack Pointer (USP) and Interrupt Stack Pointer (ISP)

The stack pointers (SP), USP and ISP, are each 16 bits wide. The U flag of FLG is used to switch between USP and ISP.

2.7 Static Base Register (SB)

SB is a 16-bit register for SB relative addressing.

2.8 Flag Register (FLG)

FLG is an 11-bit register indicating the CPU state.

2.8.1 Carry Flag (C)

The C flag retains carry, borrow, or shift-out bits that have been generated by the arithmetic and logic unit.

2.8.2 Debug Flag (D)

The D flag is for debugging only. Set it to 0.

2.8.3 Zero Flag (Z)

The Z flag is set to 1 when an arithmetic operation results in 0; otherwise to 0.

2.8.4 Sign Flag (S)

The S flag is set to 1 when an arithmetic operation results in a negative value; otherwise to 0.

2.8.5 Register Bank Select Flag (B)

Register bank 0 is selected when the B flag is 0. Register bank 1 is selected when this flag is set to 1.

2.8.6 Overflow Flag (O)

The O flag is set to 1 when an operation results in an overflow; otherwise to 0.

2.8.7 Interrupt Enable Flag (I)

The I flag enables maskable interrupts.

Interrupts are disabled when the I flag is set to 0, and are enabled when the I flag is set to 1. The I flag is set to 0 when an interrupt request is acknowledged.

2.8.8 Stack Pointer Select Flag (U)

ISP is selected when the U flag is set to 0; USP is selected when the U flag is set to 1.

The U flag is set to 0 when a hardware interrupt request is acknowledged or the INT instruction of software interrupt numbers 0 to 31 is executed.

2.8.9 Processor Interrupt Priority Level (IPL)

IPL is 3 bits wide and assigns processor interrupt priority levels from level 0 to level 7.

If a requested interrupt has higher priority than IPL, the interrupt is enabled.

2.8.10 Reserved Bit

If necessary, set to 0. When read, the content is undefined.

3. Memory

3.1 R8C/33G Group

Figure 3.1 is a Memory Map of R8C/33G Group. The R8C/33G Group has a 1-Mbyte address space from addresses 00000h to FFFFFh. For example, a 32-Kbyte internal ROM area is allocated addresses 08000h to 0FFFFh.

The fixed interrupt vector table is allocated addresses 0FFDCh to 0FFFFh. The starting address of each interrupt routine is stored here.

The internal ROM (data flash) is allocated addresses 03000h to 03FFFh.

The internal RAM is allocated higher addresses, beginning with address 00400h. For example, a 2.5-Kbyte internal RAM area is allocated addresses 00400h to 00DFFh. The internal RAM is used not only for data storage but also as a stack area when a subroutine is called or when an interrupt request is acknowledged.

Special function registers (SFRs) are allocated addresses 00000h to 002FFh and 02C00h to 02FFFh. Peripheral function control registers are allocated here. All unallocated spaces within the SFRs are reserved and cannot be accessed by users.

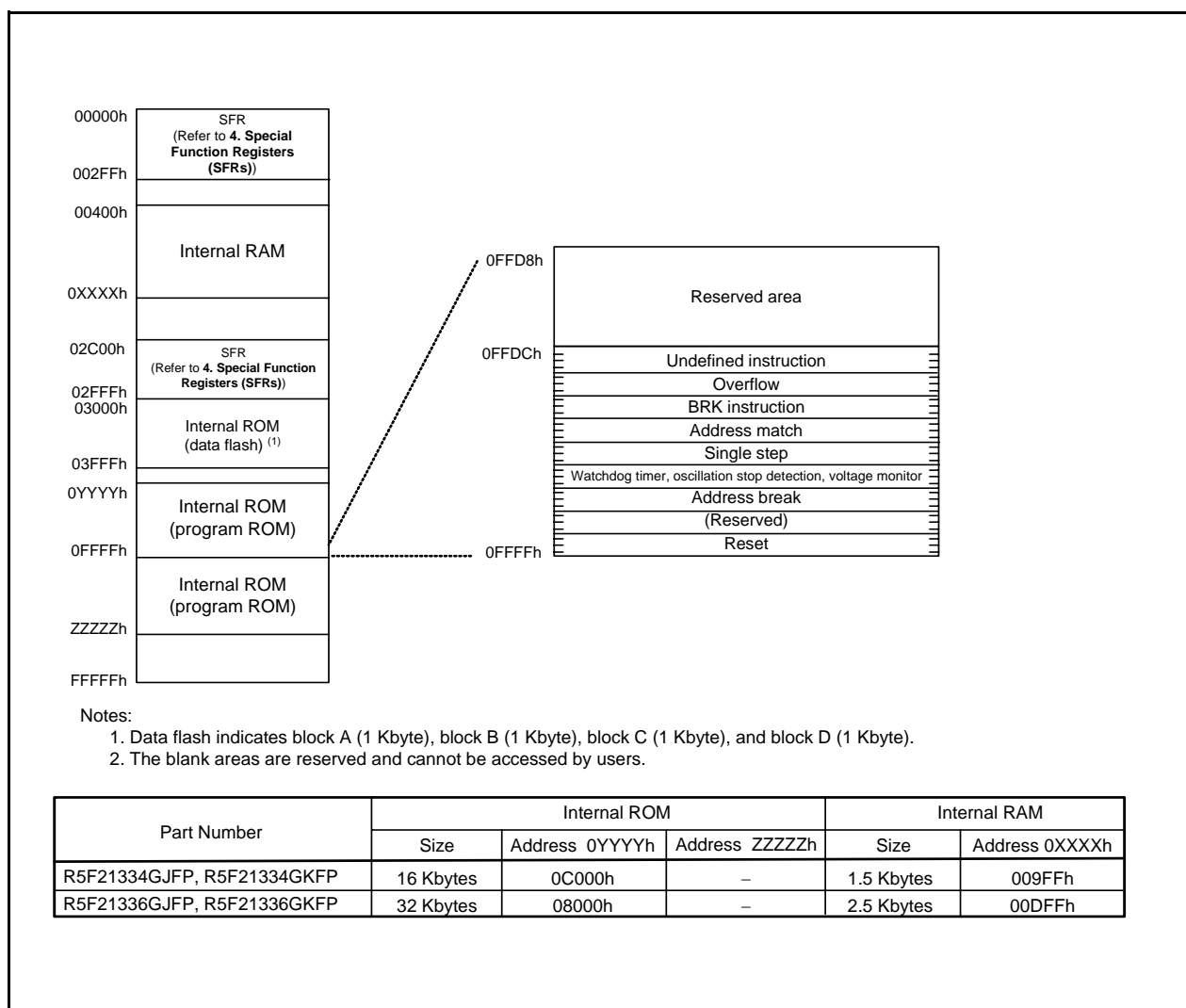

Figure 3.1 Memory Map of R8C/33G Group

3.2 R8C/33H Group

Figure 3.2 is a Memory Map of R8C/33H Group. The R8C/33H Group has a 1-Mbyte address space from addresses 00000h to FFFFFh. The internal ROM (program ROM) is allocated lower addresses, beginning with address 00FFFFh. For example, a 32-Kbyte internal ROM area is allocated addresses 08000h to 0FFFFh.

The fixed interrupt vector table is allocated addresses 0FFDCh to 0FFFFh. The starting address of each interrupt routine is stored here.

The internal RAM is allocated higher addresses, beginning with address 00400h. For example, a 2.5-Kbyte internal RAM area is allocated addresses 00400h to 00DFFh. The internal RAM is used not only for data storage but also as a stack area when a subroutine is called or when an interrupt request is acknowledged.

Special function registers (SFRs) are allocated addresses 00000h to 002FFh and 02C00h to 02FFFh. Peripheral function control registers are allocated here. All unallocated spaces within the SFRs are reserved and cannot be accessed by users.

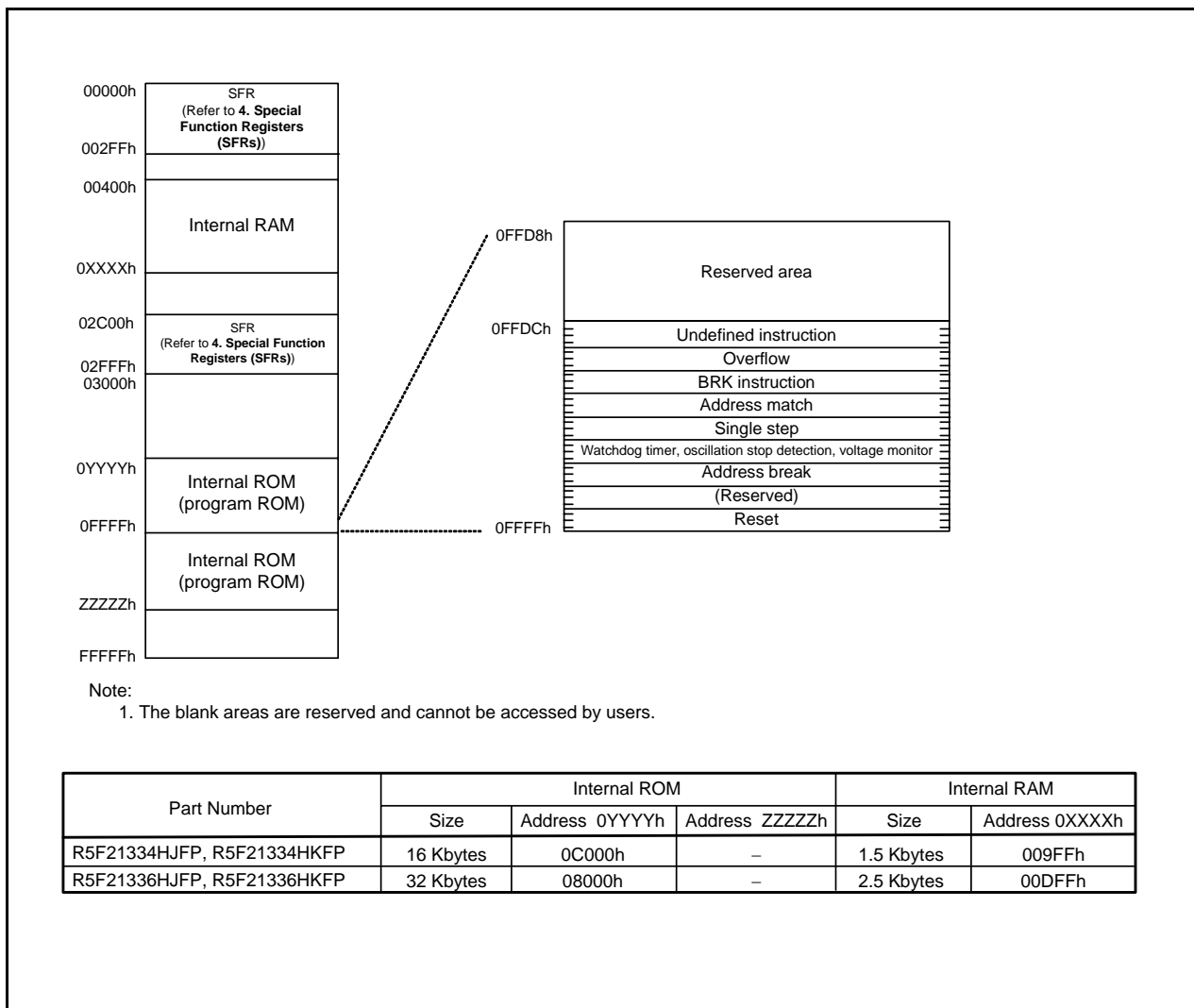

Figure 3.2 Memory Map of R8C/33H Group

4. Special Function Registers (SFRs)

An SFR (special function register) is a control register for a peripheral function. Tables 4.1 to 4.12 list the special function registers and Table 4.13 lists the ID Code Areas and Option Function Select Area.

Table 4.1 SFR Information (1) (1)

Address	Register	Symbol	After Reset
0000h			
0001h			
0002h			
0003h			
0004h	Processor Mode Register 0	PM0	00h
0005h	Processor Mode Register 1	PM1	00h
0006h	System Clock Control Register 0	CM0	00101000b
0007h	System Clock Control Register 1	CM1	00100000b
0008h	Module Standby Control Register	MSTCR	00h
0009h	System Clock Control Register 3	CM3	00h
000Ah	Protect Register	PRCR	00h
000Bh	Reset Source Determination Register	RSTFR	0XXXXXXb (2)
000Ch	Oscillation Stop Detection Register	OCD	00000100b
000Dh	Watchdog Timer Reset Register	WDTR	XXh
000Eh	Watchdog Timer Start Register	WDTS	XXh
000Fh	Watchdog Timer Control Register	WDTC	00111111b
0010h			
0011h			
0012h			
0013h			
0014h			
0015h	High-Speed On-Chip Oscillator Control Register 7	FRA7	When shipping
0016h			
0017h			
0018h			
0019h			
001Ah			
001Bh			
001Ch	Count Source Protection Mode Register	CSPR	00h 10000000b (3)
001Dh			
001Eh			
001Fh			
0020h			
0021h			
0022h			
0023h	High-Speed On-Chip Oscillator Control Register 0	FRA0	00h
0024h	High-Speed On-Chip Oscillator Control Register 1	FRA1	When shipping
0025h	High-Speed On-Chip Oscillator Control Register 2	FRA2	00h
0026h	On-Chip Reference Voltage Control Register	OCVREFCR	00h
0027h			
0028h			
0029h	High-Speed On-Chip Oscillator Control Register 4	FRA4	When Shipping
002Ah	High-Speed On-Chip Oscillator Control Register 5	FRA5	When Shipping
002Bh	High-Speed On-Chip Oscillator Control Register 6	FRA6	When Shipping
002Ch			
002Dh			
002Eh			
002Fh	High-Speed On-Chip Oscillator Control Register 3	FRA3	When shipping
0030h	Voltage Monitor Circuit Control Register	CMPA	00h
0031h	Voltage Monitor Circuit Edge Select Register	VCAC	00h
0032h			
0033h	Voltage Detect Register 1	VCA1	00001000b
0034h	Voltage Detect Register 2	VCA2	00h (4) 00100000b (5)
0035h			
0036h	Voltage Detection 1 Level Select Register	VD1LS	00000111b
0037h			
0038h	Voltage Monitor 0 Circuit Control Register	VW0C	1100X010b (4) 1100X011b (5)
0039h	Voltage Monitor 1 Circuit Control Register	VW1C	10001010b

X: Undefined

Notes:

1. The blank areas are reserved and cannot be accessed by users.
2. The CWR bit in the RSTFR register is set to 0 after power-on and voltage monitor 0 reset. Hardware reset, software reset, or watchdog timer reset does not affect this bit.
3. The CSPROINI bit in the OFS register is set to 0.
4. The LVDAS bit in the OFS register is set to 1.
5. The LVDAS bit in the OFS register is set to 0.

Table 4.2 SFR Information (2) (1)

Address	Register	Symbol	After Reset
003Ah	Voltage Monitor 2 Circuit Control Register	VW2C	10000010b
003Bh			
003Ch			
003Dh			
003Eh			
003Fh			
0040h			
0041h	Flash Memory Ready Interrupt Control Register	FMRDYIC	XXXXX000b
0042h			
0043h			
0044h			
0045h			
0046h			
0047h	Timer RC Interrupt Control Register	TRCIC	XXXXX000b
0048h	Timer RD0 Interrupt Control Register	TRD0IC	XXXXX000b
0049h	Timer RD1 Interrupt Control Register	TRD1IC	XXXXX000b
004Ah			
004Bh	UART2 Transmit Interrupt Control Register	S2TIC	XXXXX000b
004Ch	UART2 Receive Interrupt Control Register	S2RIC	XXXXX000b
004Dh	Key Input Interrupt Control Register	KUPIC	XXXXX000b
004Eh	A/D Conversion Interrupt Control Register	ADIC	XXXXX000b
004Fh	SSU Interrupt Control Register	SSUIC	XXXXX000b
0050h			
0051h	UART0 Transmit Interrupt Control Register	S0TIC	XXXXX000b
0052h	UART0 Receive Interrupt Control Register	S0RIC	XXXXX000b
0053h			
0054h			
0055h			
0056h	Timer RA Interrupt Control Register	TRAIC	XXXXX000b
0057h			
0058h	Timer RB Interrupt Control Register	TRBIC	XXXXX000b
0059h	INT1 Interrupt Control Register	INT1IC	XX00X000b
005Ah	INT3 Interrupt Control Register	INT3IC	XX00X000b
005Bh			
005Ch			
005Dh	INT0 Interrupt Control Register	INT0IC	XX00X000b
005Eh	UART2 Bus Collision Detection Interrupt Control Register	U2BCNIC	XXXXX000b
005Fh			
0060h			
0061h			
0062h			
0063h			
0064h			
0065h			
0066h			
0067h			
0068h			
0069h			
006Ah			
006Bh			
006Ch			
006Dh			
006Eh			
006Fh			
0070h			
0071h			
0072h	Voltage Monitor 1 Interrupt Control Register	VCMP1IC	XXXXX000b
0073h	Voltage Monitor 2 Interrupt Control Register	VCMP2IC	XXXXX000b
0074h			
0075h			
0076h			
0077h			
0078h			
0079h			
007Ah			
007Bh			
007Ch			
007Dh			
007Eh			
007Fh			

X: Undefined

Note:

1. The blank areas are reserved and cannot be accessed by users.

Table 4.3 SFR Information (3) (1)

Address	Register	Symbol	After Reset
0080h	DTC Activation Control Register	DTCTL	00h
0081h			
0082h			
0083h			
0084h			
0085h			
0086h			
0087h			
0088h	DTC Activation Enable Register 0	DTCEN0	00h
0089h	DTC Activation Enable Register 1	DTCEN1	00h
008Ah	DTC Activation Enable Register 2	DTCEN2	00h
008Bh	DTC Activation Enable Register 3	DTCEN3	00h
008Ch	DTC Activation Enable Register 4	DTCEN4	00h
008Dh			
008Eh	DTC Activation Enable Register 6	DTCEN6	00h
008Fh			
0090h			
0091h			
0092h			
0093h			
0094h			
0095h			
0096h			
0097h			
0098h			
0099h			
009Ah			
009Bh			
009Ch			
009Dh			
009Eh			
009Fh			
00A0h	UART0 Transmit/Receive Mode Register	U0MR	00h
00A1h	UART0 Bit Rate Register	U0BRG	XXh
00A2h	UART0 Transmit Buffer Register	U0TB	XXh
00A3h			XXh
00A4h	UART0 Transmit/Receive Control Register 0	U0C0	00001000b
00A5h	UART0 Transmit/Receive Control Register 1	U0C1	00000010b
00A6h	UART0 Receive Buffer Register	U0RB	XXh
00A7h			XXh
00A8h	UART2 Transmit/Receive Mode Register	U2MR	00h
00A9h	UART2 Bit Rate Register	U2BRG	XXh
00AAh	UART2 Transmit Buffer Register	U2TB	XXh
00ABh			XXh
00ACh	UART2 Transmit/Receive Control Register 0	U2C0	00001000b
00ADh	UART2 Transmit/Receive Control Register 1	U2C1	00000010b
00AEh	UART2 Receive Buffer Register	U2RB	XXh
00AFh			XXh
00B0h	UART2 Digital Filter Function Select Register	URXDF	00h
00B1h			
00B2h			
00B3h			
00B4h			
00B5h			
00B6h			
00B7h			
00B8h			
00B9h			
00BAh			
00BBh	UART2 Special Mode Register 5	U2SMR5	00h
00BCh	UART2 Special Mode Register 4	U2SMR4	00h
00BDh	UART2 Special Mode Register 3	U2SMR3	000X0X0Xb
00BEh	UART2 Special Mode Register 2	U2SMR2	X0000000b
00BFh	UART2 Special Mode Register	U2SMR	X0000000b

X: Undefined

Note:

1. The blank areas are reserved and cannot be accessed by users.

Table 4.4 SFR Information (4) (1)

Address	Register	Symbol	After Reset
00C0h	A/D Register 0	AD0	XXh
00C1h			000000XXb
00C2h	A/D Register 1	AD1	XXh
00C3h			000000XXb
00C4h	A/D Register 2	AD2	XXh
00C5h			000000XXb
00C6h	A/D Register 3	AD3	XXh
00C7h			000000XXb
00C8h	A/D Register 4	AD4	XXh
00C9h			000000XXb
00CAh	A/D Register 5	AD5	XXh
00CBh			000000XXb
00CCh	A/D Register 6	AD6	XXh
00CDh			000000XXb
00CEh	A/D Register 7	AD7	XXh
00CFh			000000XXb
00D0h			
00D1h			
00D2h			
00D3h			
00D4h	A/D Mode Register	ADMOD	00h
00D5h	A/D Input Select Register	ADINSEL	11000000b
00D6h	A/D Control Register 0	ADCON0	00h
00D7h	A/D Control Register 1	ADCON1	00h
00D8h	D/A0 Register	DA0	00h
00D9h	D/A1 Register	DA1	00h
00DAh			
00DBh			
00DCh	D/A Control Register	DACON	00h
00DDh			
00DEh			
00DFh			
00E0h	Port P0 Register	P0	XXh
00E1h	Port P1 Register	P1	XXh
00E2h	Port P0 Direction Register	PD0	00h
00E3h	Port P1 Direction Register	PD1	00h
00E4h			
00E5h	Port P3 Register	P3	XXh
00E6h			
00E7h	Port P3 Direction Register	PD3	00h
00E8h	Port P4 Register	P4	XXh
00E9h	Port P5 Register	P5	XXh
00EAh	Port P4 Direction Register	PD4	00h
00EBh	Port P5 Direction Register	PD5	00h
00ECh			
00EDh			
00EEh			
00EFh			
00F0h			
00F1h			
00F2h			
00F3h			
00F4h			
00F5h			
00F6h			
00F7h			
00F8h			
00F9h			
00FAh			
00FBh			
00FCh			
00FDh			
00FEh			
00FFh			

X: Undefined

Note:

1. The blank areas are reserved and cannot be accessed by users.

Table 4.5 SFR Information (5) (1)

Address	Register	Symbol	After Reset
0100h	Timer RA Control Register	TRACR	00h
0101h	Timer RA I/O Control Register	TRAIOC	00h
0102h	Timer RA Mode Register	TRAMR	00h
0103h	Timer RA Prescaler Register	TRAPRE	FFh
0104h	Timer RA Register	TRA	FFh
0105h	LIN Control Register 2	LINCR2	00h
0106h	LIN Control Register	LINCR	00h
0107h	LIN Status Register	LINST	00h
0108h	Timer RB Control Register	TRBCR	00h
0109h	Timer RB One-Shot Control Register	TRBOCR	00h
010Ah	Timer RB I/O Control Register	TRBIOC	00h
010Bh	Timer RB Mode Register	TRBMR	00h
010Ch	Timer RB Prescaler Register	TRBPRE	FFh
010Dh	Timer RB Secondary Register	TRBSC	FFh
010Eh	Timer RB Primary Register	TRBPR	FFh
010Fh			
0110h			
0111h			
0112h			
0113h			
0114h			
0115h			
0116h			
0117h			
0118h			
0119h			
011Ah			
011Bh			
011Ch			
011Dh			
011Eh			
011Fh			
0120h	Timer RC Mode Register	TRCMR	01001000b
0121h	Timer RC Control Register 1	TRCCR1	00h
0122h	Timer RC Interrupt Enable Register	TRCIER	01110000b
0123h	Timer RC Status Register	TRCSR	01110000b
0124h	Timer RC I/O Control Register 0	TRCIOR0	10001000b
0125h	Timer RC I/O Control Register 1	TRCIOR1	10001000b
0126h	Timer RC Counter	TRC	00h
0127h			00h
0128h	Timer RC General Register A	TRCGRA	FFh
0129h			FFh
012Ah	Timer RC General Register B	TRCGRB	FFh
012Bh			FFh
012Ch	Timer RC General Register C	TRCGRC	FFh
012Dh			FFh
012Eh	Timer RC General Register D	TRCGRD	FFh
012Fh			FFh
0130h	Timer RC Control Register 2	TRCCR2	00011000b
0131h	Timer RC Digital Filter Function Select Register	TRCDF	00h
0132h	Timer RC Output Master Enable Register	TRCOER	01111111b
0133h	Timer RC Trigger Control Register	TRCADCR	00h
0134h			
0135h			
0136h	Timer RD Trigger Control Register	TRDADCR	00h
0137h	Timer RD Start Register	TRDSTR	11111100b
0138h	Timer RD Mode Register	TRDMR	00001110b
0139h	Timer RD PWM Mode Register	TRDPMR	10001000b
013Ah	Timer RD Function Control Register	TRDFCR	10000000b
013Bh	Timer RD Output Master Enable Register 1	TRDOER1	FFh
013Ch	Timer RD Output Master Enable Register 2	TRDOER2	01111111b
013Dh	Timer RD Output Control Register	TRDOCR	00h
013Eh	Timer RD Digital Filter Function Select Register 0	TRDDF0	00h
013Fh	Timer RD Digital Filter Function Select Register 1	TRDDF1	00h

Note:

1. The blank areas are reserved and cannot be accessed by users.

Table 4.6 SFR Information (6) (1)

Address	Register	Symbol	After Reset
0140h	Timer RD Control Register 0	TRDCR0	00h
0141h	Timer RD I/O Control Register A0	TRDIORA0	10001000b
0142h	Timer RD I/O Control Register C0	TRDIORC0	10001000b
0143h	Timer RD Status Register 0	TRDSR0	11100000b
0144h	Timer RD Interrupt Enable Register 0	TRDIER0	11100000b
0145h	Timer RD PWM Mode Output Level Control Register 0	TRDPOCR0	11111000b
0146h	Timer RD Counter 0	TRD0	00h
0147h			00h
0148h	Timer RD General Register A0	TRDGRA0	FFh
0149h			FFh
014Ah	Timer RD General Register B0	TRDGRB0	FFh
014Bh			FFh
014Ch	Timer RD General Register C0	TRDGRC0	FFh
014Dh			FFh
014Eh	Timer RD General Register D0	TRDGRD0	FFh
014Fh			FFh
0150h	Timer RD Control Register 1	TRDCR1	00h
0151h	Timer RD I/O Control Register A1	TRDIORA1	10001000b
0152h	Timer RD I/O Control Register C1	TRDIORC1	10001000b
0153h	Timer RD Status Register 1	TRDSR1	11000000b
0154h	Timer RD Interrupt Enable Register 1	TRDIER1	11100000b
0155h	Timer RD PWM Mode Output Level Control Register 1	TRDPOCR1	11111000b
0156h	Timer RD Counter 1	TRD1	00h
0157h			00h
0158h	Timer RD General Register A1	TRDGRA1	FFh
0159h			FFh
015Ah	Timer RD General Register B1	TRDGRB1	FFh
015Bh			FFh
015Ch	Timer RD General Register C1	TRDGRC1	FFh
015Dh			FFh
015Eh	Timer RD General Register D1	TRDGRD1	FFh
015Fh			FFh
0160h			
0161h			
0162h			
0163h			
0164h			
0165h			
0166h			
0167h			
0168h			
0169h			
016Ah			
016Bh			
016Ch			
016Dh			
016Eh			
016Fh			
0170h			
0171h			
0172h			
0173h			
0174h			
0175h			
0176h			
0177h			
0178h			
0179h			
017Ah			
017Bh			
017Ch			
017Dh			
017Eh			
017Fh			

X: Undefined

Note:

1. The blank areas are reserved and cannot be accessed by users.

Table 4.7 SFR Information (7) (1)

Address	Register	Symbol	After Reset
0180h	Timer RA Pin Select Register	TRASR	00h
0181h	Timer RB/RC Pin Select Register	TRBRCSR	00h
0182h	Timer RC Pin Select Register 0	TRCPSR0	00h
0183h	Timer RC Pin Select Register 1	TRCPSR1	00h
0184h	Timer RD Pin Select Register 0	TRDPSR0	00h
0185h	Timer RD Pin Select Register 1	TRDPSR1	00h
0186h			
0187h			
0188h	UART0 Pin Select Register	U0SR	00h
0189h			
018Ah	UART2 Pin Select Register 0	U2SR0	00h
018Bh	UART2 Pin Select Register 1	U2SR1	00h
018Ch	SSU Pin Select Register	SSUICSR	00h
018Dh			
018Eh	INT Interrupt Input Pin Select Register	INTSR	00h
018Fh	I/O Function Pin Select Register	PINSR	00h
0190h			
0191h			
0192h			
0193h	SS Bit Counter Register	SSBR	11111000b
0194h	SS Transmit Data Register L	SSTDR	FFh
0195h	SS Transmit Data Register H	SSTDRH	FFh
0196h	SS Receive Data Register L	SSRDR	FFh
0197h	SS Receive Data Register H	SSRDRH	FFh
0198h	SS Control Register H	SSCRH	00h
0199h	SS Control Register L	SSCRL	01111101b
019Ah	SS Mode Register	SSMR	00010000b
019Bh	SS Enable Register	SSER	00h
019Ch	SS Status Register	SSSR	00h
019Dh	SS Mode Register 2	SSMR2	00h
019Eh			
019Fh			
01A0h			
01A1h			
01A2h			
01A3h			
01A4h			
01A5h			
01A6h			
01A7h			
01A8h			
01A9h			
01AAh			
01ABh			
01ACh			
01ADh			
01AEh			
01AFh			
01B0h			
01B1h			
01B2h	Flash Memory Status Register	FST	10000X00b
01B3h			
01B4h	Flash Memory Control Register 0	FMR0	00h
01B5h	Flash Memory Control Register 1	FMR1	00h
01B6h	Flash Memory Control Register 2	FMR2	00h
01B7h			
01B8h			
01B9h			
01BAh			
01BBh			
01BCh			
01BDh			
01BEh			
01BFh			

X: Undefined

Note:

1. The blank areas are reserved and cannot be accessed by users.

Table 4.8 SFR Information (8) (1)

Address	Register	Symbol	After Reset
01C0h	Address Match Interrupt Register 0	RMAD0	XXh
01C1h			XXh
01C2h			0000XXXXb
01C3h	Address Match Interrupt Enable Register 0	AIER0	00h
01C4h			XXh
01C5h	Address Match Interrupt Register 1	RMAD1	XXh
01C6h			XXh
01C7h			0000XXXXb
01C8h	Address Match Interrupt Enable Register 1	AIER1	00h
01C9h			
01CAh			
01CBh			
01CCh			
01CDh			
01CEh			
01CFh			
01D0h			
01D1h			
01D2h			
01D3h			
01D4h			
01D5h			
01D6h			
01D7h			
01D8h			
01D9h			
01DAh			
01DBh			
01DCh			
01DDh			
01DEh			
01DFh			
01E0h	Pull-Up Control Register 0	PUR0	00h
01E1h	Pull-Up Control Register 1	PUR1	00h
01E2h			
01E3h			
01E4h			
01E5h			
01E6h			
01E7h			
01E8h			
01E9h			
01EAh			
01EBh			
01ECh			
01EDh			
01EEh			
01EFh			
01F0h			
01F1h			
01F2h			
01F3h			
01F4h			
01F5h	Input Threshold Control Register 0	VLT0	00h
01F6h	Input Threshold Control Register 1	VLT1	00h
01F7h			
01F8h	Comparator B Control Register 0	INTCMP	00h
01F9h			
01FAh	External Input Enable Register 0	INTEN	00h
01FBh			
01FCh	INT Input Filter Select Register 0	INTF	00h
01FDh			
01FEh	Key Input Enable Register 0	KIEN	00h
01FFh			

X: Undefined

Note:

1. The blank areas are reserved and cannot be accessed by users.

Table 4.9 SFR Information (9) (1)

Address	Register	Symbol	After Reset
2C00h	DTC Transfer Vector Area		XXh
2C01h	DTC Transfer Vector Area		XXh
2C02h			XXh
2C03h	DTC Transfer Vector Area		XXh
2C04h			XXh
2C05h			XXh
2C06h			XXh
2C07h			XXh
2C08h	DTC Transfer Vector Area		XXh
2C09h	DTC Transfer Vector Area		XXh
2C0Ah	DTC Transfer Vector Area		XXh
2C0Bh	DTC Transfer Vector Area		XXh
2C0Ch			XXh
2C0Dh			XXh
2C0Eh	DTC Transfer Vector Area		XXh
2C0Fh	DTC Transfer Vector Area		XXh
2C10h	DTC Transfer Vector Area		XXh
2C11h	DTC Transfer Vector Area		XXh
2C12h	DTC Transfer Vector Area		XXh
2C13h	DTC Transfer Vector Area		XXh
2C14h			XXh
2C15h			XXh
2C16h	DTC Transfer Vector Area		XXh
2C17h	DTC Transfer Vector Area		XXh
2C18h	DTC Transfer Vector Area		XXh
2C19h	DTC Transfer Vector Area		XXh
2C1Ah	DTC Transfer Vector Area		XXh
2C1Bh	DTC Transfer Vector Area		XXh
2C1Ch	DTC Transfer Vector Area		XXh
2C1Dh	DTC Transfer Vector Area		XXh
2C1Eh	DTC Transfer Vector Area		XXh
2C1Fh	DTC Transfer Vector Area		XXh
2C20h	DTC Transfer Vector Area		XXh
2C21h	DTC Transfer Vector Area		XXh
2C22h			
:			
:			
2C30h			
2C31h	DTC Transfer Vector Area		XXh
2C32h			XXh
2C33h	DTC Transfer Vector Area		XXh
2C34h	DTC Transfer Vector Area		XXh
2C35h			XXh
2C36h			XXh
2C37h			XXh
2C38h			XXh
2C39h			XXh
2C3Ah			XXh
2C3Bh			XXh
2C3Ch			XXh
2C3Dh			XXh
2C3Eh			XXh
2C3Fh			XXh
2C40h	DTC Control Data 0	DTCD0	XXh
2C41h			XXh
2C42h			XXh
2C43h			XXh
2C44h			XXh
2C45h			XXh
2C46h			XXh
2C47h			XXh
2C48h	DTC Control Data 1	DTCD1	XXh
2C49h			XXh
2C4Ah			XXh
2C4Bh			XXh
2C4Ch			XXh
2C4Dh			XXh
2C4Eh			XXh
2C4Fh			XXh

X: Undefined

Note:

1. The blank areas are reserved and cannot be accessed by users.

Table 4.10 SFR Information (10) (1)

Address	Register	Symbol	After Reset
2C50h	DTC Control Data 2	DTCD2	XXh
2C51h			XXh
2C52h			XXh
2C53h			XXh
2C54h			XXh
2C55h			XXh
2C56h			XXh
2C57h			XXh
2C58h	DTC Control Data 3	DTCD3	XXh
2C59h			XXh
2C5Ah			XXh
2C5Bh			XXh
2C5Ch			XXh
2C5Dh			XXh
2C5Eh			XXh
2C5Fh			XXh
2C60h	DTC Control Data 4	DTCD4	XXh
2C61h			XXh
2C62h			XXh
2C63h			XXh
2C64h			XXh
2C65h			XXh
2C66h			XXh
2C67h			XXh
2C68h	DTC Control Data 5	DTCD5	XXh
2C69h			XXh
2C6Ah			XXh
2C6Bh			XXh
2C6Ch			XXh
2C6Dh			XXh
2C6Eh			XXh
2C6Fh			XXh
2C70h	DTC Control Data 6	DTCD6	XXh
2C71h			XXh
2C72h			XXh
2C73h			XXh
2C74h			XXh
2C75h			XXh
2C76h			XXh
2C77h			XXh
2C78h	DTC Control Data 7	DTCD7	XXh
2C79h			XXh
2C7Ah			XXh
2C7Bh			XXh
2C7Ch			XXh
2C7Dh			XXh
2C7Eh			XXh
2C7Fh			XXh
2C80h	DTC Control Data 8	DTCD8	XXh
2C81h			XXh
2C82h			XXh
2C83h			XXh
2C84h			XXh
2C85h			XXh
2C86h			XXh
2C87h			XXh
2C88h	DTC Control Data 9	DTCD9	XXh
2C89h			XXh
2C8Ah			XXh
2C8Bh			XXh
2C8Ch			XXh
2C8Dh			XXh
2C8Eh			XXh
2C8Fh			XXh
2C90h	DTC Control Data 10	DTCD10	XXh
2C91h			XXh
2C92h			XXh
2C93h			XXh
2C94h			XXh
2C95h			XXh
2C96h			XXh
2C97h			XXh

X: Undefined

Note:

1. The blank areas are reserved and cannot be accessed by users.

Table 4.11 SFR Information (11) (1)

Address	Register	Symbol	After Reset
2C98h	DTC Control Data 11	DTCD11	XXh
2C99h			XXh
2C9Ah			XXh
2C9Bh			XXh
2C9Ch			XXh
2C9Dh			XXh
2C9Eh			XXh
2C9Fh			XXh
2CA0h	DTC Control Data 12	DTCD12	XXh
2CA1h			XXh
2CA2h			XXh
2CA3h			XXh
2CA4h			XXh
2CA5h			XXh
2CA6h			XXh
2CA7h			XXh
2CA8h	DTC Control Data 13	DTCD13	XXh
2CA9h			XXh
2CAAh			XXh
2CABh			XXh
2CACH			XXh
2CADh			XXh
2CAEh			XXh
2CAFh			XXh
2CB0h	DTC Control Data 14	DTCD14	XXh
2CB1h			XXh
2CB2h			XXh
2CB3h			XXh
2CB4h			XXh
2CB5h			XXh
2CB6h			XXh
2CB7h			XXh
2CB8h	DTC Control Data 15	DTCD15	XXh
2CB9h			XXh
2CBAh			XXh
2CBBh			XXh
2CBCh			XXh
2CBDh			XXh
2CBEh			XXh
2CBFh			XXh
2CC0h	DTC Control Data 16	DTCD16	XXh
2CC1h			XXh
2CC2h			XXh
2CC3h			XXh
2CC4h			XXh
2CC5h			XXh
2CC6h			XXh
2CC7h			XXh
2CC8h	DTC Control Data 17	DTCD17	XXh
2CC9h			XXh
2CCAh			XXh
2CCBh			XXh
2CCCh			XXh
2CCDh			XXh
2CCEh			XXh
2CCFh			XXh
2CD0h	DTC Control Data 18	DTCD18	XXh
2CD1h			XXh
2CD2h			XXh
2CD3h			XXh
2CD4h			XXh
2CD5h			XXh
2CD6h			XXh
2CD7h			XXh
2CD8h	DTC Control Data 19	DTCD19	XXh
2CD9h			XXh
2CDAh			XXh
2CDBh			XXh
2CDCh			XXh
2CDDh			XXh
2CDEh			XXh
2CDFh			XXh

X: Undefined

Note:

1. The blank areas are reserved and cannot be accessed by users.

Table 4.12 SFR Information (12) (1)

Address	Register	Symbol	After Reset
2CE0h	DTC Control Data 20	DTCD20	XXh
2CE1h			XXh
2CE2h			XXh
2CE3h			XXh
2CE4h			XXh
2CE5h			XXh
2CE6h			XXh
2CE7h			XXh
2CE8h	DTC Control Data 21	DTCD21	XXh
2CE9h			XXh
2CEAh			XXh
2CEBh			XXh
2CECh			XXh
2CEDh			XXh
2CEEh			XXh
2CEFh			XXh
2CF0h	DTC Control Data 22	DTCD22	XXh
2CF1h			XXh
2CF2h			XXh
2CF3h			XXh
2CF4h			XXh
2CF5h			XXh
2CF6h			XXh
2CF7h			XXh
2CF8h	DTC Control Data 23	DTCD23	XXh
2CF9h			XXh
2CFAh			XXh
2CFBh			XXh
2CFCh			XXh
2CFDh			XXh
2CFEh			XXh
2CFFh			XXh
2D00h			
⋮			
2FFh			

X: Undefined

Note:

- The blank areas are reserved and cannot be accessed by users.

Table 4.13 ID Code Areas and Option Function Select Area

Address	Area Name	Symbol	After Reset
⋮			
FFDBh	Option Function Select Register 2	OFS2	(Note 1)
⋮			
FFDFh	ID1		(Note 2)
⋮			
FFE3h	ID2		(Note 2)
⋮			
FFEBh	ID3		(Note 2)
⋮			
FFEFh	ID4		(Note 2)
⋮			
FFF3h	ID5		(Note 2)
⋮			
FFF7h	ID6		(Note 2)
⋮			
FFFBh	ID7		(Note 2)
⋮			
FFFFh	Option Function Select Register	OFS	(Note 1)

Notes:

- The option function select area is allocated in the flash memory, not in the SFRs. Set appropriate values as ROM data by a program. Do not write additions to the option function select area. If the block including the option function select area is erased, the option function select area is set to FFh. When blank products are shipped, the option function select area is set to FFh. It is set to the written value after written by the user. When factory-programming products are shipped, the value of the option function select area is the value programmed by the user.
- The ID code areas are allocated in the flash memory, not in the SFRs. Set appropriate values as ROM data by a program. Do not write additions to the ID code areas. If the block including the ID code areas is erased, the ID code areas are set to FFh. When blank products are shipped, the ID code areas are set to FFh. They are set to the written value after written by the user. When factory-programming products are shipped, the value of the ID code areas is the value programmed by the user.

5. Resets

The following resets are implemented: hardware reset, power-on reset, voltage monitor 0 reset, watchdog timer reset, and software reset.

Table 5.1 lists the Reset Names and Sources. Figure 5.1 shows a Block Diagram of Reset Circuit.

Table 5.1 Reset Names and Sources

Reset Name	Source
Hardware reset	Input voltage of $\overline{\text{RESET}}$ pin is held "L"
Power-on reset	VCC rises
Voltage monitor 0 reset	VCC falls (monitor voltage: Vdet0)
Watchdog timer reset	Underflow of watchdog timer
Software reset	Write 1 to PM03 bit in PM0 register

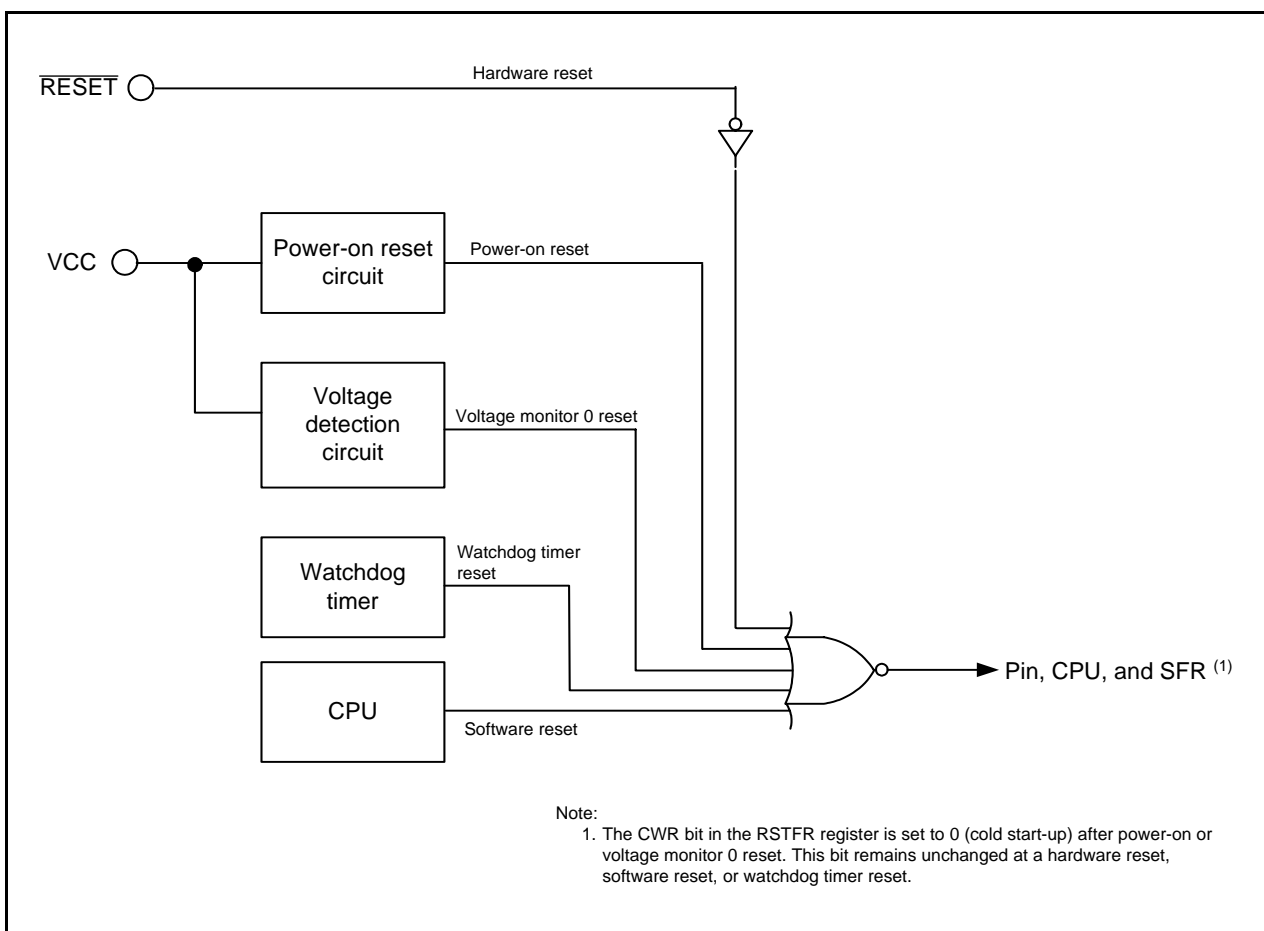

Figure 5.1 Block Diagram of Reset Circuit

Table 5.2 lists the Pin Functions while $\overline{\text{RESET}}$ Pin Level is “L”, Figure 5.2 shows the CPU Register Status after Reset, Figure 5.3 shows the Reset Sequence.

Table 5.2 Pin Functions while $\overline{\text{RESET}}$ Pin Level is “L”

Pin Name	Pin Function
P0 to P1, P3_1, P3_3 to P3_7	Input port
P4_2, P4_5 to P4_7	Input port
P5_3 to P5_4	Input port

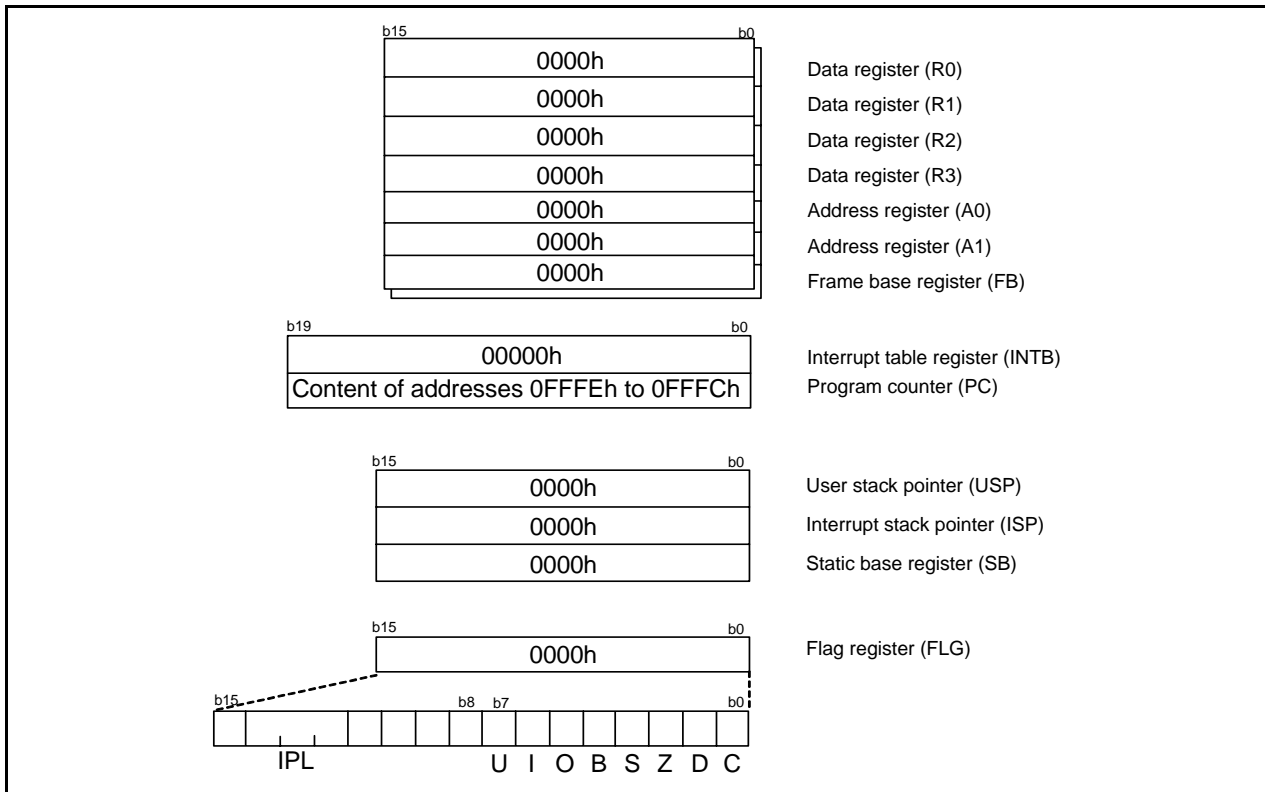

Figure 5.2 CPU Register Status after Reset

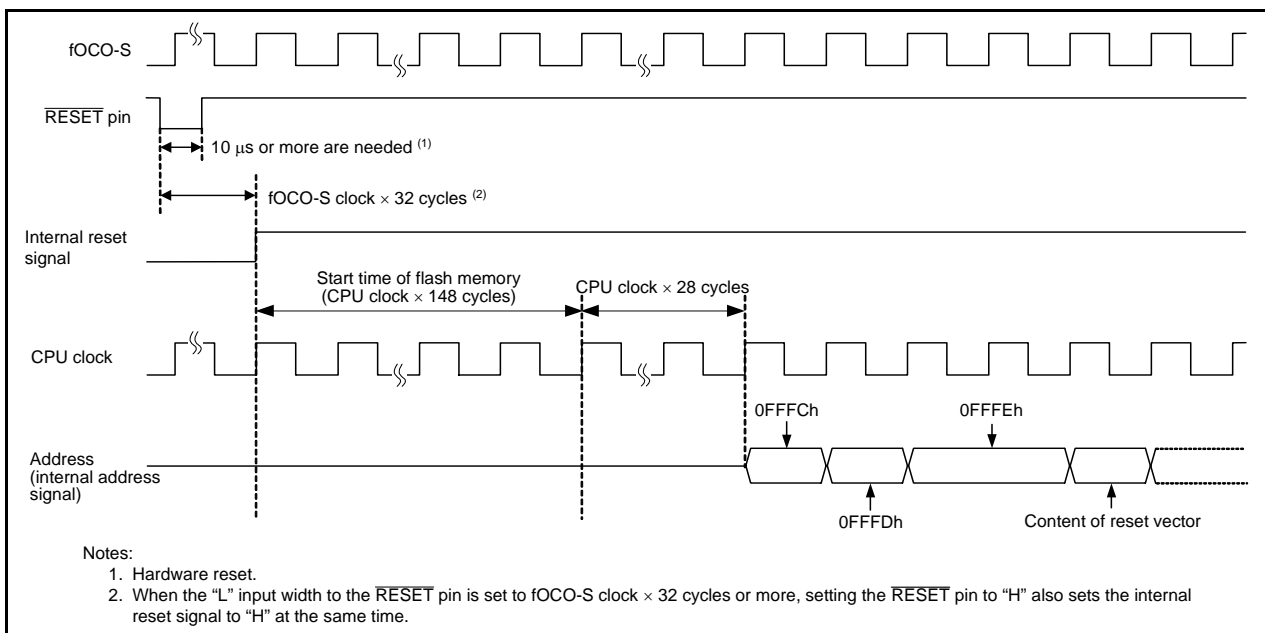

Figure 5.3 Reset Sequence

5.1 Registers

5.1.1 Processor Mode Register 0 (PM0)

Address 0004h

Bit	b7	b6	b5	b4	b3	b2	b1	b0
Symbol	—	—	—	—	PM03	—	—	—
After Reset	0	0	0	0	0	0	0	0

Bit	Symbol	Bit Name	Function	R/W
b0	—	Reserved bits	Set to 0.	R/W
b1	—			
b2	—			
b3	PM03	Software reset bit	The MCU is reset when this bit is set to 1. When read, the content is 0.	R/W
b4	—	Nothing is assigned. If necessary, set to 0. When read, the content is 0.		—
b5	—			
b6	—			
b7	—			

Set the PRC1 bit in the PRCR register to 1 (write enabled) before rewriting the PM0 register.

5.1.2 Reset Source Determination Register (RSTFR)

Address 000Bh

Bit	b7	b6	b5	b4	b3	b2	b1	b0
Symbol	—	—	—	—	WDR	SWR	HWR	CWR
After Reset	0	X	X	X	X	X	X	X

(Note 1)

Bit	Symbol	Bit Name	Function	R/W
b0	CWR	Cold start-up/warm start-up determine flag ^(2, 3)	0: Cold start-up 1: Warm start-up	R/W
b1	HWR	Hardware reset detect flag	0: Not detected 1: Detected	R
b2	SWR	Software reset detect flag	0: Not detected 1: Detected	R
b3	WDR	Watchdog timer reset detect flag	0: Not detected 1: Detected	R
b4	—	Reserved bits	When read, the content is undefined.	R
b5	—			
b6	—			
b7	—	Reserved bit	Set to 0.	R/W

Notes:

1. The CWR bit is set to 0 (cold start-up) after power-on or voltage monitor 0 reset. This bit remains unchanged at a hardware reset, software reset, or watchdog timer reset.
2. If 1 is written to the CWR bit by a program, it is set to 1. (Writing 0 does not affect this bit.)
3. When the VWOC0 bit in the VWOC register is set to 0 (voltage monitor 0 reset disabled), the CWR bit value is undefined.

5.1.3 Option Function Select Register (OFS)

Address 0FFFFh

Bit	b7	b6	b5	b4	b3	b2	b1	b0
Symbol	CSPROINI	LVDAS	—	—	ROMCP1	ROMCR	—	WDTON
After Reset	User Setting Value ⁽¹⁾							

Bit	Symbol	Bit Name	Function	R/W
b0	WDTON	Watchdog timer start select bit	0: Watchdog timer automatically starts after reset 1: Watchdog timer is stopped after reset	R/W
b1	—	Reserved bit	Set to 1.	R/W
b2	ROMCR	ROM code protect disable bit	0: ROM code protect disabled 1: ROMCP1 bit enabled	R/W
b3	ROMCP1	ROM code protect bit	0: ROM code protect enabled 1: ROM code protect disabled	R/W
b4	—	Reserved bit	Set to 1.	R/W
b5	—	Reserved bit	Set to 0.	R/W
b6	LVDAS	Voltage detection 0 circuit start bit ⁽²⁾	0: Voltage monitor 0 reset enabled after reset 1: Voltage monitor 0 reset disabled after reset	R/W
b7	CSPROINI	Count source protection mode after reset select bit	0: Count source protect mode enabled after reset 1: Count source protect mode disabled after reset	R/W

Notes:

- The OFS register is allocated in the flash memory, not in the SFRs. Set appropriate values as ROM data by a program.
Do not write additions to the OFS register. If the block including the OFS register is erased, the OFS register is set to FFh.
When blank products are shipped, the OFS register is set to FFh. It is set to the written value after written by the user.
When factory-programming products are shipped, the value of the OFS register is the value programmed by the user.
- To use power-on reset and voltage monitor 0 reset, set the LVDAS bit to 0 (voltage monitor 0 reset enabled after reset).

For a setting example of the OFS register, refer to **13.3.1 Setting Example of Option Function Select Area**.

5.1.4 Option Function Select Register 2 (OFS2)

Address 0FFDBh

Bit	b7	b6	b5	b4	b3	b2	b1	b0
Symbol	—	—	—	—	WDTRCS1	WDTRCS0	WDTUFS1	WDTUFS0
After Reset	User Setting Value ⁽¹⁾							

Bit	Symbol	Bit Name	Function	R/W
b0	WDTUFS0	Watchdog timer underflow period set bit	^{b1 b0} 0 0: 03FFh 0 1: 0FFFh 1 0: 1FFFh 1 1: 3FFFh	R/W
b1	WDTUFS1			R/W
b2	WDTRCS0	Watchdog timer refresh acknowledgement period set bit	^{b3 b2} 0 0: 25% 0 1: 50% 1 0: 75% 1 1: 100%	R/W
b3	WDTRCS1			R/W
b4	—	Reserved bits	Set to 1.	R/W
b5	—			
b6	—			
b7	—			

Note:

- The OFS2 register is allocated in the flash memory, not in the SFRs. Set appropriate values as ROM data by a program.
Do not write additions to the OFS2 register. If the block including the OFS2 register is erased, the OFS2 register is set to FFh.
When blank products are shipped, the OFS2 register is set to FFh. It is set to the written value after written by the user.
When factory-programming products are shipped, the value of the OFS2 register is the value programmed by the user.

For a setting example of the OFS2 register, refer to **13.3.1 Setting Example of Option Function Select Area**.

Bits WDTRCS0 and WDTRCS1 (Watchdog Timer Refresh Acknowledgement Period Set Bit)

Assuming that the period from when the watchdog timer starts counting until it underflows is 100%, the refresh acknowledgement period for the watchdog timer can be selected.
For details, refer to **14.3.1.1 Refresh Acknowledgement Period**.

5.2 Hardware Reset

A reset is applied using the $\overline{\text{RESET}}$ pin. When an “L” signal is applied to the $\overline{\text{RESET}}$ pin while the supply voltage meets the recommended operating conditions, pins, CPU, and SFRs are all reset (refer to **Table 5.2 Pin Functions while RESET Pin Level is “L”**, **Figure 5.2 CPU Register Status after Reset**, and **Table 4.1 to Table 4.12 SFR Information**).

When the input level applied to the $\overline{\text{RESET}}$ pin changes from “L” to “H”, a program is executed beginning with the address indicated by the reset vector. After reset, the low-speed on-chip oscillator clock with no division is automatically selected as the CPU clock.

Refer to **4. Special Function Registers (SFRs)** for the states of the SFRs after reset.

The internal RAM is not reset. If the $\overline{\text{RESET}}$ pin is pulled “L” while writing to the internal RAM is in progress, the contents of internal RAM will be undefined.

Figure 5.4 shows an Example of Hardware Reset Circuit and Operation and Figure 5.5 shows an Example of Hardware Reset Circuit (Usage Example of External Supply Voltage Detection Circuit) and Operation.

5.2.1 When Power Supply is Stable

- (1) Apply “L” to the $\overline{\text{RESET}}$ pin.
- (2) Wait for 10 μs .
- (3) Apply “H” to the $\overline{\text{RESET}}$ pin.

5.2.2 Power On

- (1) Apply “L” to the $\overline{\text{RESET}}$ pin.
- (2) Let the supply voltage increase until it meets the recommended operating conditions.
- (3) Wait for $t_{\text{d(P-R)}}$ or more to allow the internal power supply to stabilize (refer to **30. Electrical Characteristics**).
- (4) Wait for 10 μs .
- (5) Apply “H” to the $\overline{\text{RESET}}$ pin.

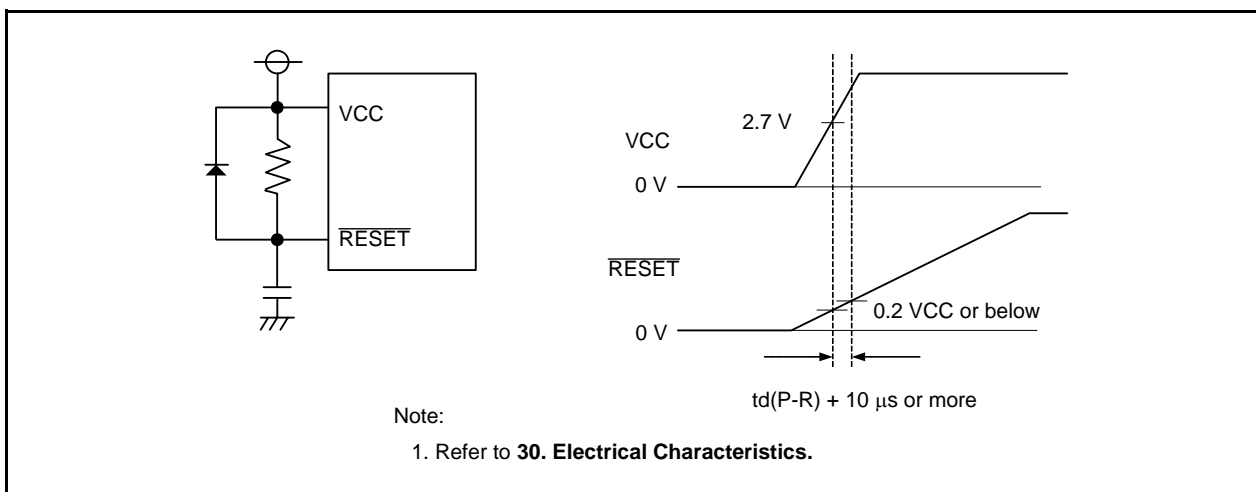

Figure 5.4 Example of Hardware Reset Circuit and Operation

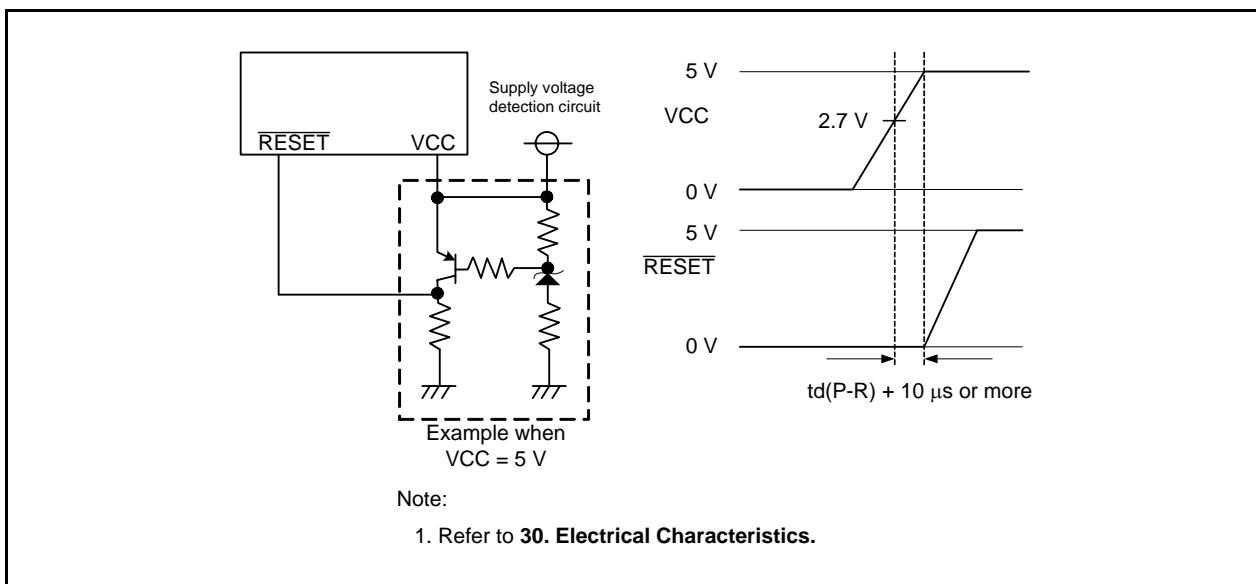

Figure 5.5 Example of Hardware Reset Circuit (Usage Example of External Supply Voltage Detection Circuit) and Operation

5.3 Power-On Reset Function

When the $\overline{\text{RESET}}$ pin is connected to the VCC pin via a pull-up resistor, and the VCC pin voltage level rises, the power-on reset function is enabled and the MCU resets its pins, CPU, and SFR. When a capacitor is connected to the $\overline{\text{RESET}}$ pin, too, always keep the voltage to the $\overline{\text{RESET}}$ pin $0.8V_{\text{CC}}$ or more.

When the input voltage to the VCC pin reaches the V_{det0} level or above, the low-speed on-chip oscillator clock starts counting. When the low-speed on-chip oscillator clock count reaches 32, the internal reset signal is held “H” and the MCU enters the reset sequence (refer to Figure 5.3). The low-speed on-chip oscillator clock with no division is automatically selected as the CPU clock after reset.

Refer to **4. Special Function Registers (SFRs)** for the states of the SFR after power-on reset.

To use the power-on reset function, enable voltage monitor 0 reset by setting the LVDAS bit in the OFS register to 0.

Figure 5.6 shows an Example of Power-On Reset Circuit and Operation.

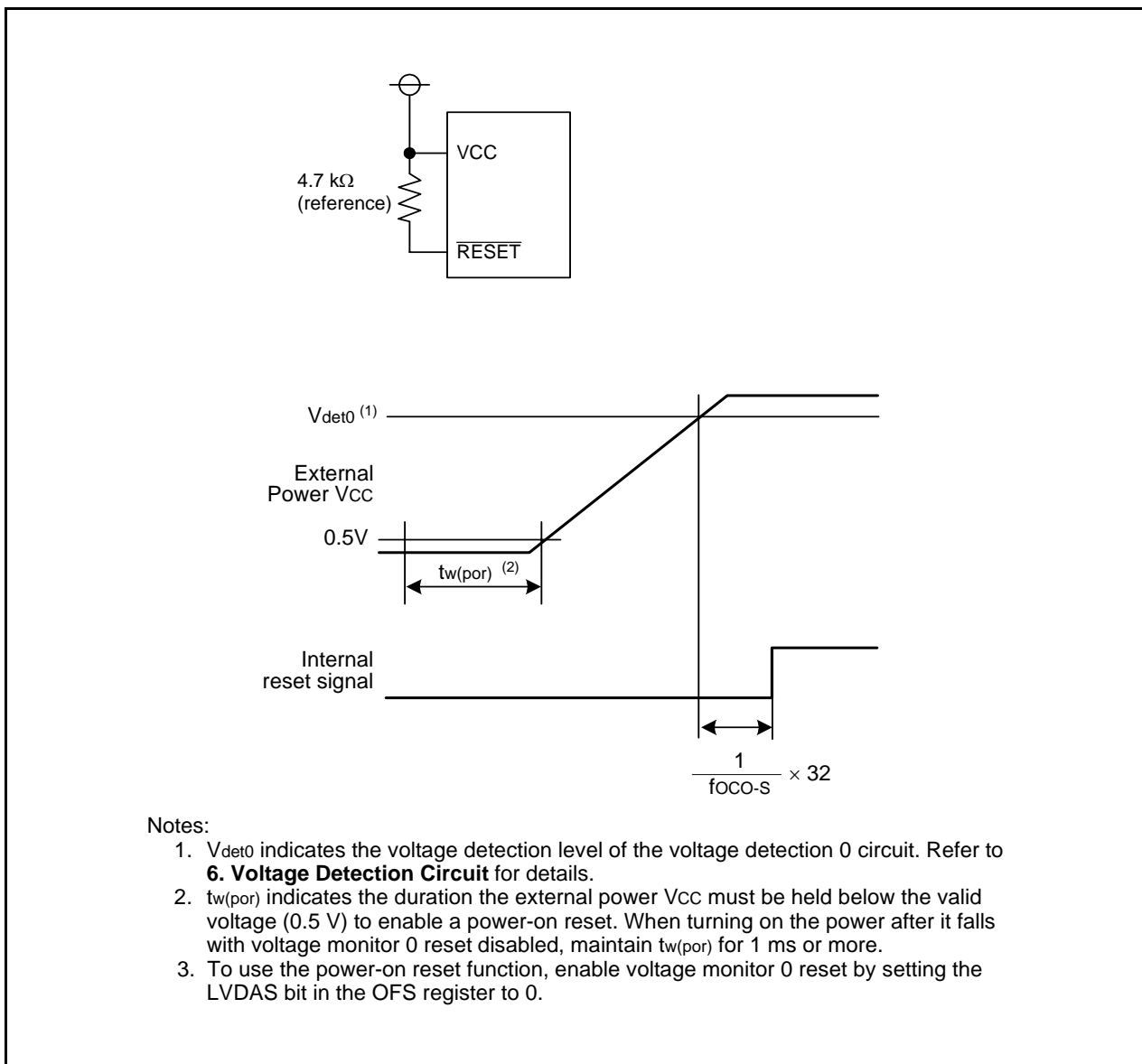

Figure 5.6 Example of Power-On Reset Circuit and Operation

5.4 Voltage Monitor 0 Reset

A reset is applied using the voltage detection 0 circuit. The voltage detection 0 circuit monitors the input voltage to the VCC pin. The voltage to be monitored is Vdet0.

To use voltage monitor 0 reset, set the LVDAS bit in the OFS register to 0.

When the VCC pin voltage reaches the Vdet0 level or below, the internal reset signal is held low. When the VCC pin voltage then reaches the Vdet0 level or above, the MCU enters the reset sequence (refer to Figure 5.3) and the low-speed on-chip oscillator clock starts counting. When the low-speed on-chip oscillator clock count reaches 32, the internal reset signal is held high.

After 176 cycles of the CPU clock has elapsed, a program is executed by reading the reset vector. The low-speed on-chip oscillator clock with no division is automatically selected as the CPU clock.

Refer to **3. Memory** for the status of internal RAM after reset and **4. Special Function Registers (SFRs)** for the status of the SFR.

If a voltage monitor 0 reset occurs while writing to internal RAM is in progress, the contents of the internal RAM are undefined. Refer to **6. Voltage Detection Circuit** for details of voltage monitor 0 reset. Refer to **5.1.3 Option Function Select Register (OFS)**.

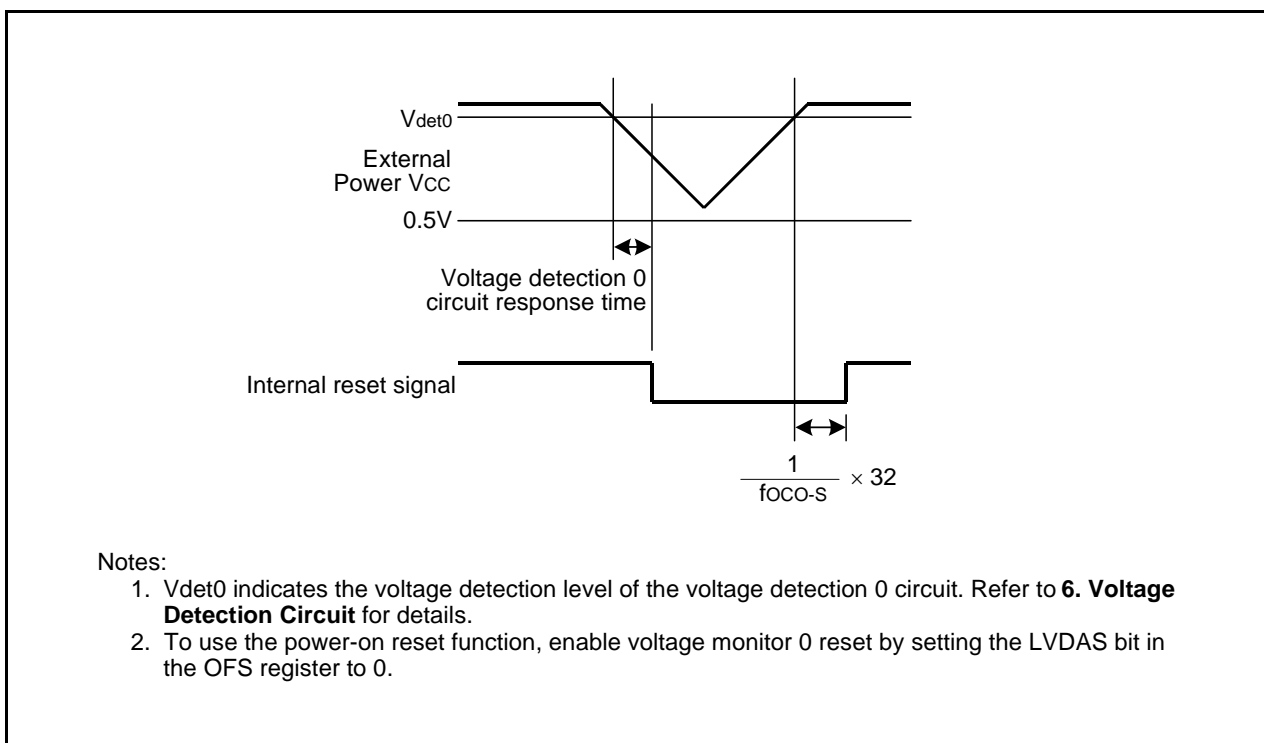

Figure 5.7 Example of Voltage Monitor 0 Reset Circuit and Operation

5.5 Watchdog Timer Reset

When the PM12 bit in the PM1 register is set to 1 (reset when watchdog timer underflows), the MCU resets its pins, CPU, and SFR if the watchdog timer underflows. Then the program beginning with the address indicated by the reset vector is executed. After reset, the low-speed on-chip oscillator clock with no division is automatically selected as the CPU clock.

Refer to **4. Special Function Registers (SFRs)** for the states of the SFRs after watchdog timer reset.

The internal RAM is not reset. When the watchdog timer underflows while writing to the internal RAM is in progress, the contents of internal RAM are undefined.

The underflow period and refresh acknowledge period for the watchdog timer can be set by bits WDTUFS0 to WDTUFS1 and bits WDTRCS0 to WDTRCS1 in the OFS2 register, respectively.

Refer to **14. Watchdog Timer** for details of the watchdog timer.

5.6 Software Reset

When the PM03 bit in the PM0 register is set to 1 (MCU reset), the MCU resets its pins, CPU, and SFR. The program beginning with the address indicated by the reset vector is executed. After reset, the low-speed on-chip oscillator clock with no division is automatically selected for the CPU clock.

Refer to **4. Special Function Registers (SFRs)** for the states of the SFRs after software reset.

The internal RAM is not reset.

5.7 Cold Start-Up/Warm Start-Up Determination Function

The cold start-up/warm start-up determination function uses the CWR bit in the RSTFR register to determine cold start-up (reset process) at power-on and warm start-up (reset process) when a reset occurred during operation.

The CWR bit is set to 0 (cold start-up) at power-on and also set to 0 at a voltage monitor 0 reset. If 1 is written to the CWR bit by a program, it is set to 1. This bit remains unchanged at a hardware reset, software reset, or watchdog timer reset.

The cold start-up/warm start-up determination function uses voltage monitor 0 reset.

Figure 5.8 shows an Operating Example of Cold Start-Up/Warm Start-Up Function

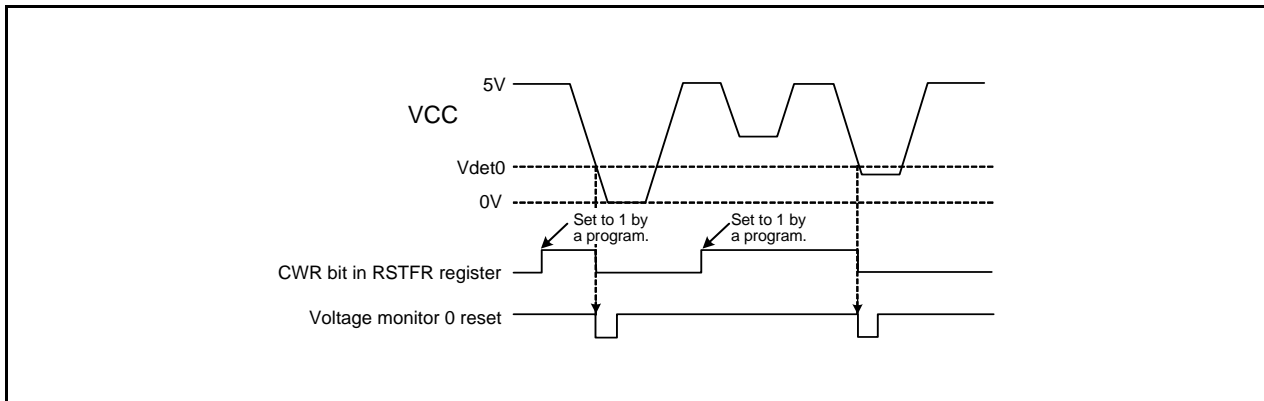

Figure 5.8 Operating Example of Cold Start-Up/Warm Start-Up Function

5.8 Reset Source Determination Function

The RSTFR register can be used to detect whether a hardware reset, software reset, or watchdog timer reset has occurred.

If a hardware reset occurs, the HWR bit is set to 1 (detected). If a software reset occurs, the SWR bit is set to 1 (detected). If a watchdog timer reset occurs, the WDR bit is set to 1 (detected).

6. Voltage Detection Circuit

The voltage detection circuit monitors the voltage input to the VCC pin. This circuit can be used to monitor the VCC input voltage by a program.

6.1 Overview

The detection voltage of voltage detection 0 is fixed level (typical 2.85 V).

The detection voltage of voltage detection 1 can be selected among 8 levels using the VD1LS register.

The detection voltage of voltage detection 2 is fixed level (typical 4.00 V).

The voltage monitor 0 reset, and voltage monitor 1 interrupt and voltage monitor 2 interrupt can also be used.

Table 6.1 Voltage Detection Circuit Specifications

Item		Voltage Monitor 0	Voltage Monitor 1	Voltage Monitor 2
VCC monitor	Voltage to monitor	Vdet0	Vdet1	Vdet2
	Detection target	Whether passing through Vdet0 by falling	Whether passing through Vdet1 by rising or falling	Whether passing through Vdet2 by rising or falling
	Detection voltage	The fixed level	Selectable among 8 levels using the VD1LS register.	The fixed level
	Monitor	None	The VW1C3 bit in the VW1C register Whether VCC is higher or lower than Vdet1	The VCA13 bit in the VCA1 register Whether VCC is higher or lower than Vdet2
Process at voltage detection	Reset	Voltage monitor 0 reset	None	None
		Reset at Vdet0 > VCC; CPU operation restarts at VCC > Vdet0		
	Interrupts	None	Voltage monitor 1 interrupt Non-maskable or maskable selectable Interrupt request at: Vdet1 > VCC and/or VCC > Vdet1	Voltage monitor 2 interrupt Non-maskable or maskable selectable Interrupt request at: Vdet2 > VCC and/or VCC > Vdet2
Digital filter	Switching enable/disable	No digital filter function	Supported	Supported
	Sampling time	—	(fOCO-S divided by n) × 2 n: 1, 2, 4, and 8	(fOCO-S divided by n) × 2 n: 1, 2, 4, and 8

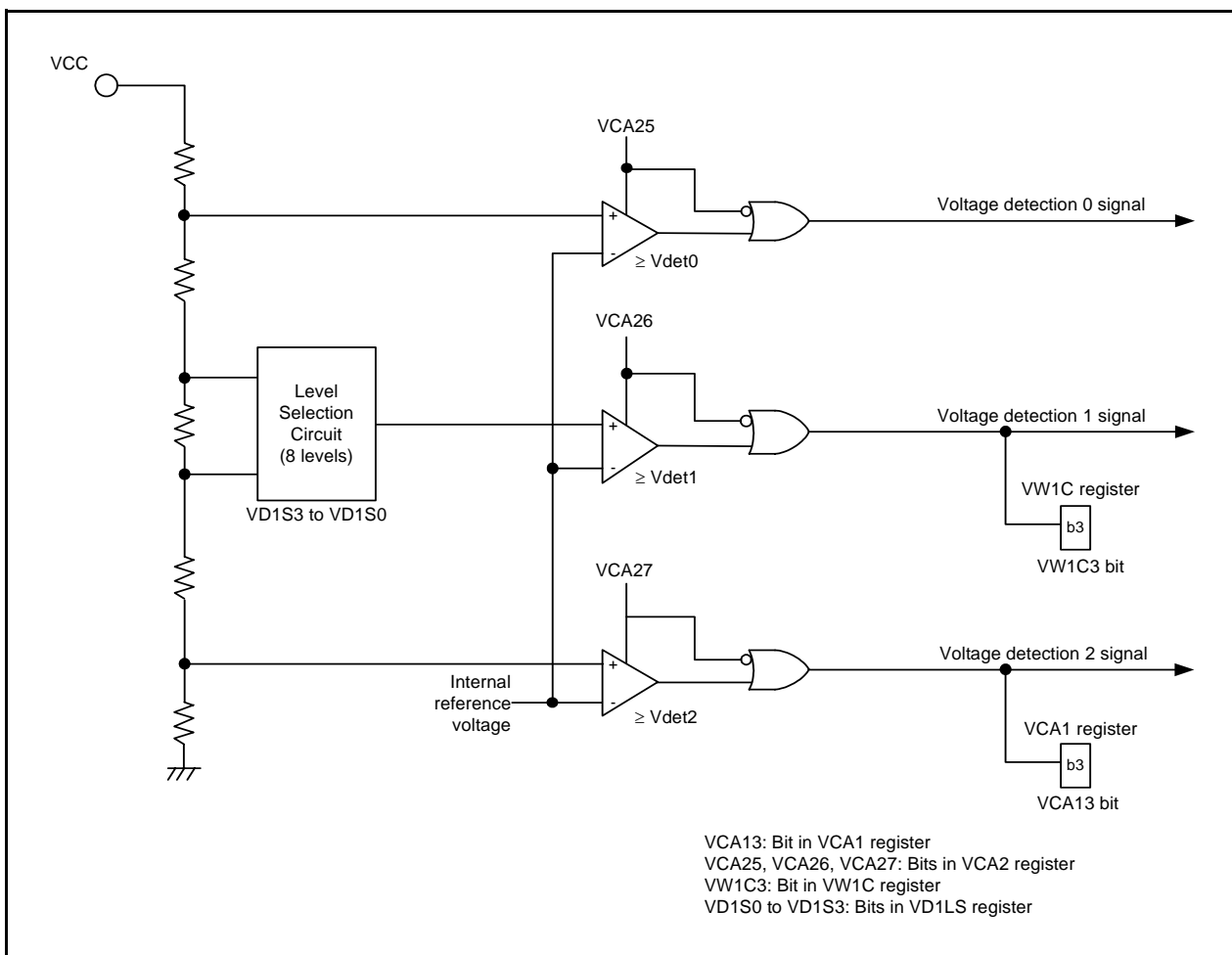

Figure 6.1 Voltage Detection Circuit Block Diagram

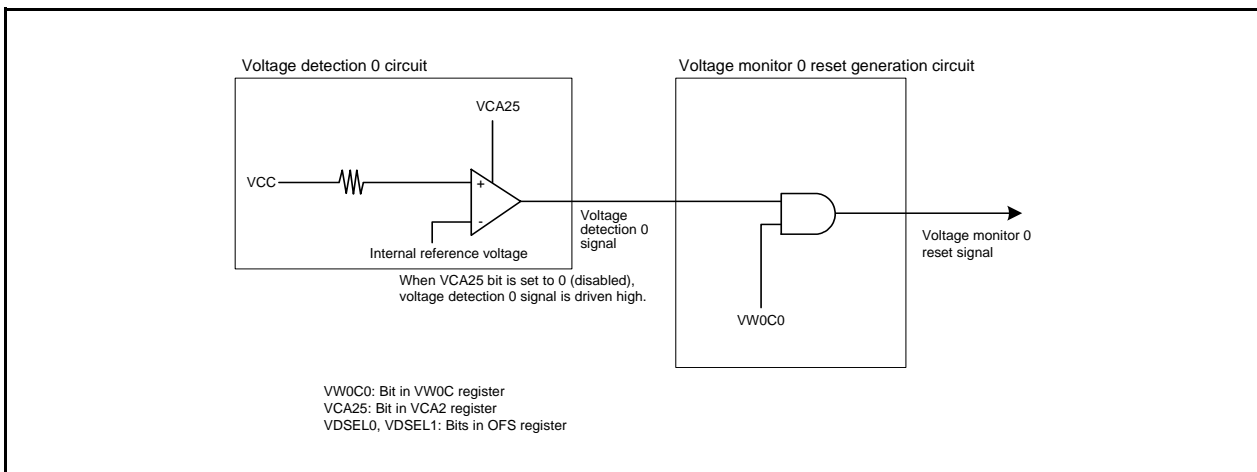

Figure 6.2 Block Diagram of Voltage Monitor 0 Reset Generation Circuit

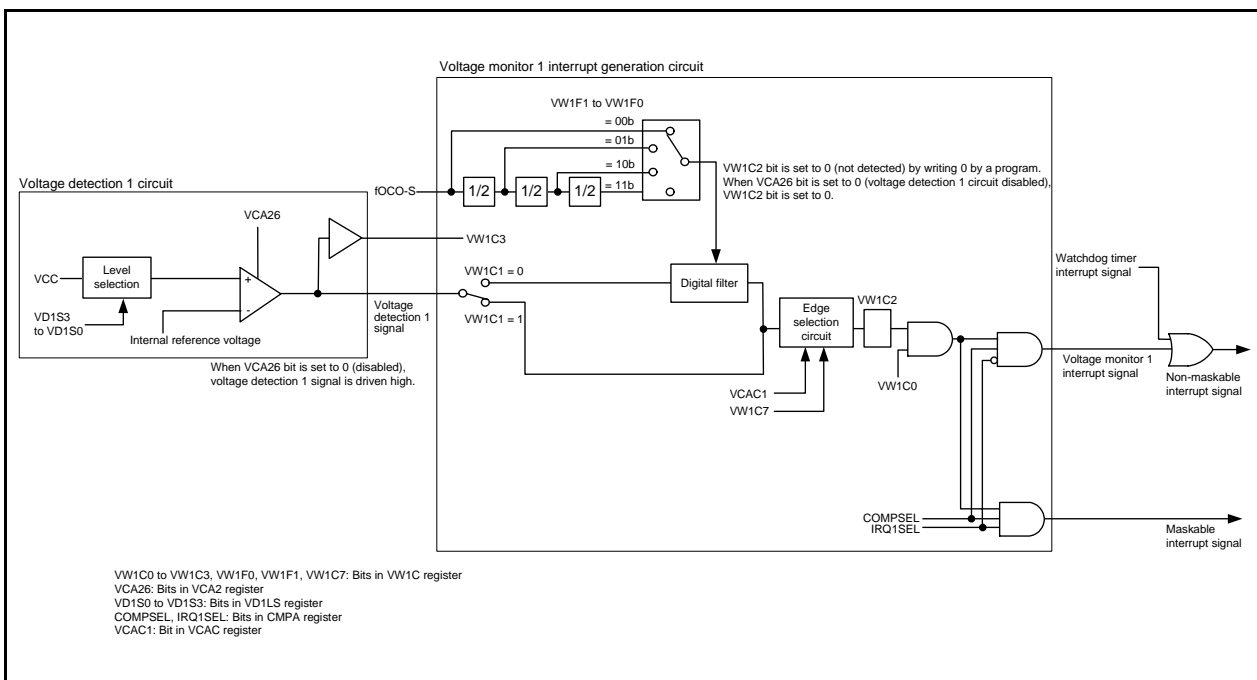

Figure 6.3 Block Diagram of Voltage Monitor 1 Interrupt Generation Circuit

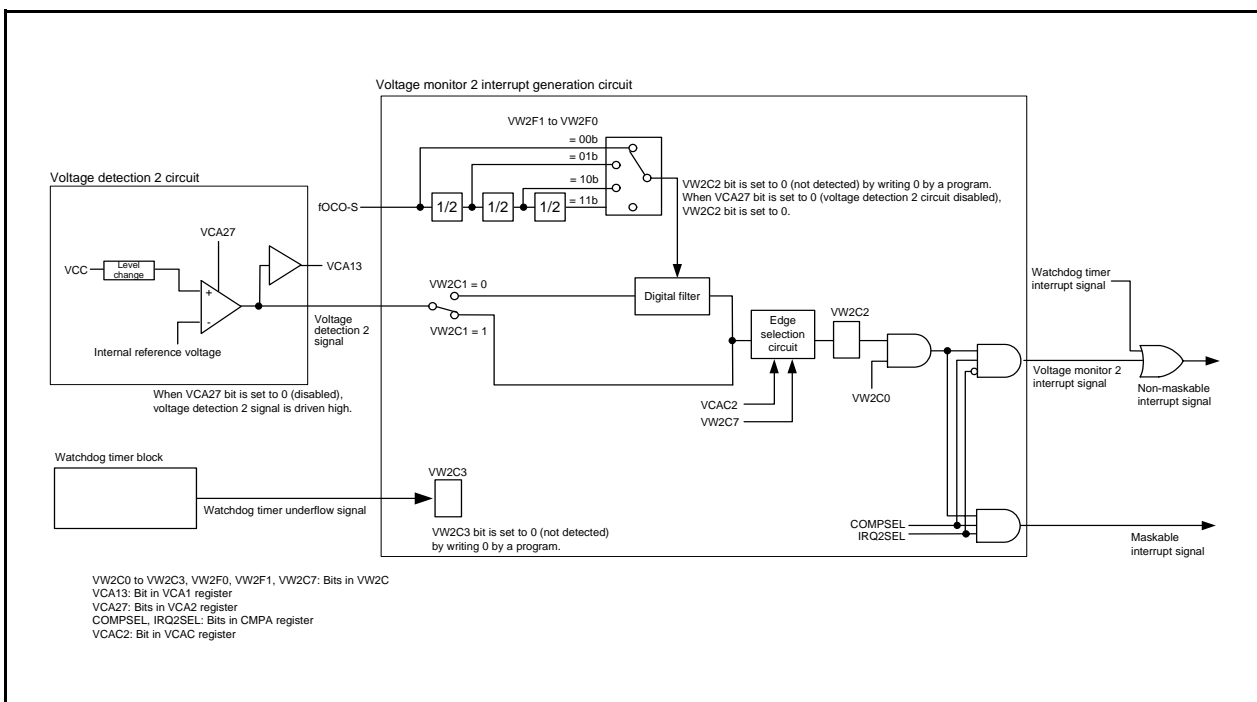

Figure 6.4 Block Diagram of Voltage Monitor 2 Interrupt Generation Circuit

6.2 Registers

6.2.1 Voltage Monitor Circuit Control Register (CMPA)

Address 0030h

Bit	b7	b6	b5	b4	b3	b2	b1	b0
Symbol	COMPSEL	—	IRQ2SEL	IRQ1SEL	—	—	—	—
After Reset	0	0	0	0	0	0	0	0

Bit	Symbol	Bit Name	Function	R/W
b0	—	Reserved bits	Set to 0.	R/W
b1	—			
b2	—			
b3	—			
b4	IRQ1SEL	Voltage monitor 1 interrupt type select bit (1)	0: Non-maskable interrupt 1: Maskable interrupt	R/W
b5	IRQ2SEL	Voltage monitor 2 interrupt type select bit (2)	0: Non-maskable interrupt 1: Maskable interrupt	R/W
b6	—	Reserved bit	Set to 0.	R/W
b7	COMPSEL	Voltage monitor interrupt type selection enable bit (1, 2)	0: Bits IRQ1SEL and IRQ2SEL disabled 1: Bits IRQ1SEL and IRQ2SEL enabled	R/W

Notes:

1. When the VW1C0 bit in the VW1C register is set to 1 (enabled), do not set bits IRQ1SEL and COMPSEL simultaneously (with one instruction).
2. When the VW2C0 bit in the VW2C register is set to 1 (enabled), do not set bits IRQ2SEL and COMPSEL simultaneously (with one instruction).

6.2.2 Voltage Monitor Circuit Edge Select Register (VCAC)

Address 0031h

Bit	b7	b6	b5	b4	b3	b2	b1	b0
Symbol	—	—	—	—	—	VCAC2	VCAC1	—
After Reset	0	0	0	0	0	0	0	0

Bit	Symbol	Bit Name	Function	R/W
b0	—	Nothing is assigned. If necessary, set to 0. When read, the content is 0.		—
b1	VCAC1	Voltage monitor 1 circuit edge select bit ⁽¹⁾	0: One edge 1: Both edges	R/W
b2	VCAC2	Voltage monitor 2 circuit edge select bit ⁽²⁾	0: One edge 1: Both edges	R/W
b3	—	Nothing is assigned. If necessary, set to 0. When read, the content is 0.		—
b4	—			
b5	—			
b6	—			
b7	—			

Notes:

- When the VCAC1 bit is set to 0 (one edge), the VW1C7 bit in the VW1C register is enabled. Set the VW1C7 bit after setting the VCAC1 bit to 0.
- When the VCAC2 bit is set to 0 (one edge), the VW2C7 bit in the VW2C register is enabled. Set the VW2C7 bit after setting the VCAC2 bit to 0.

6.2.3 Voltage Detect Register 1 (VCA1)

Address 0033h

Bit	b7	b6	b5	b4	b3	b2	b1	b0
Symbol	—	—	—	—	VCA13	—	—	—
After Reset	0	0	0	0	1	0	0	0

Bit	Symbol	Bit Name	Function	R/W
b0	—	Reserved bits	Set to 0.	R/W
b1	—			
b2	—			
b3	VCA13	Voltage detection 2 signal monitor flag ⁽¹⁾	0: VCC < Vdet2 1: VCC ≥ Vdet2 or voltage detection 2 circuit disabled	R
b4	—	Reserved bits	Set to 0.	R/W
b5	—			
b6	—			
b7	—			

Note:

- When the VCA27 bit in the VCA2 register is set to 1 (voltage detection 2 circuit enabled), the VCA13 bit is enabled.
When the VCA27 bit in the VCA2 register is set to 0 (voltage detection 2 circuit disabled), the VCA13 bit is set to 1 (VCC ≥ Vdet2).

6.2.4 Voltage Detect Register 2 (VCA2)

Address 0034h

Bit	b7	b6	b5	b4	b3	b2	b1	b0
Symbol	VCA27	VCA26	VCA25	—	—	—	—	VCA20
After Reset	0	0	0	0	0	0	0	0
	The above applies when the LVDAS bit in the OFS register is set to 1.							
After Reset	0	0	1	0	0	0	0	0
	The above applies when the LVDAS bit in the OFS register is set to 0.							

Bit	Symbol	Bit Name	Function	R/W
b0	VCA20	Internal power low consumption enable bit ⁽¹⁾	0: Low consumption disabled 1: Low consumption enabled ⁽²⁾	R/W
b1	—	Reserved bits	Set to 0.	R/W
b2	—			
b3	—			
b4	—			
b5	VCA25	Voltage detection 0 enable bit ⁽³⁾	0: Voltage detection 0 circuit disabled 1: Voltage detection 0 circuit enabled	R/W
b6	VCA26	Voltage detection 1 enable bit ⁽⁴⁾	0: Voltage detection 1 circuit disabled 1: Voltage detection 1 circuit enabled	R/W
b7	VCA27	Voltage detection 2 enable bit ⁽⁵⁾	0: Voltage detection 2 circuit disabled 1: Voltage detection 2 circuit enabled	R/W

Notes:

1. Use the VCA20 bit only when the MCU enters wait mode. To set the VCA20 bit, follow the procedure shown in **29.2.9 Reducing Internal Power Consumption Using VCA20 Bit**.
2. When the VCA20 bit is set to 1 (low consumption enabled), do not set the CM10 bit in the CM1 register to 1 (stop mode).
3. When writing to the VCA25 bit, set a value after reset.
4. To use the voltage detection 1 interrupt or the VW1C3 bit in the VW1C register, set the VCA26 bit to 1. After the VCA26 bit is set to 1 from 0, allow td(E-A) to elapse before the voltage detection 1 circuit starts operation.
5. To use the voltage detection 2 interrupt or the VCA13 bit in the VCA1 register, set the VCA27 bit to 1. After the VCA27 bit is set to 1 from 0, allow td(E-A) to elapse before the voltage detection 2 circuit starts operation.

Set the PRC3 bit in the PRCR register to 1 (write enabled) before rewriting the VCA2 register.

6.2.5 Voltage Detection 1 Level Select Register (VD1LS)

Address 0036h

Bit	b7	b6	b5	b4	b3	b2	b1	b0
Symbol	—	—	—	—	VD1S3	VD1S2	VD1S1	VD1S0
After Reset	0	0	0	0	0	1	1	1

Bit	Symbol	Bit Name	Function	R/W
b0	VD1S0	Voltage detection 1 level select bit (Reference voltage when the voltage falls)	b3 b2 b1 b0 0 0 0 0: Do not set.	R/W
b1	VD1S1		0 0 0 1: Do not set.	R/W
b2	VD1S2		0 0 1 0: Do not set.	R/W
b3	VD1S3		0 0 1 1: Do not set. 0 1 0 0: Do not set. 0 1 0 1: Do not set. 0 1 1 0: Do not set. 0 1 1 1: 3.25 V (Vdet1_7) 1 0 0 0: 3.40 V (Vdet1_8) 1 0 0 1: 3.55 V (Vdet1_9) 1 0 1 0: 3.70 V (Vdet1_A) 1 0 1 1: 3.85 V (Vdet1_B) 1 1 0 0: 4.00 V (Vdet1_C) 1 1 0 1: 4.15 V (Vdet1_D) 1 1 1 0: 4.30 V (Vdet1_E) 1 1 1 1: Do not set.	R/W
b4	—	Reserved bits	Set to 0.	R/W
b5	—			
b6	—			
b7	—			

Set the PRC3 bit in the PRCR register to 1 (write enabled) before rewriting the VD1LS register.

6.2.6 Voltage Monitor 0 Circuit Control Register (VW0C)

Address 0038h

Bit	b7	b6	b5	b4	b3	b2	b1	b0
Symbol	—	—	—	—	—	—	—	VW0C0
After Reset	1	1	0	0	X	0	1	0

The above applies when the LVDAS bit in the OFS register is set to 1.

After Reset	1	1	0	0	X	0	1	1
-------------	---	---	---	---	---	---	---	---

The above applies when the LVDAS bit in the OFS register is set to 0.

Bit	Symbol	Bit Name	Function	R/W
b0	VW0C0	Voltage monitor 0 reset enable bit ⁽¹⁾	0: Disabled 1: Enabled	R/W
b1	—	Reserved bit	Set to 1.	R/W
b2	—	Reserved bit	Set to 0.	R/W
b3	—	Reserved bit	When read, the content is undefined.	R
b4	—	Reserved bits	Set to 0.	R/W
b5	—			
b6	—	Reserved bits	Set to 1.	R/W
b7	—			

Note:

1. The VW0C0 bit is enabled when the VCA25 bit in the VCA2 register is set to 1 (voltage detection 0 circuit enabled). When writing to the VW0C0 bit, set a value after reset.

Set the PRC3 bit in the PRCR register to 1 (write enabled) before writing the VW0C register.

6.2.7 Voltage Monitor 1 Circuit Control Register (VW1C)

Address 0039h

Bit	b7	b6	b5	b4	b3	b2	b1	b0
Symbol	VW1C7	—	VW1F1	VW1F0	VW1C3	VW1C2	VW1C1	VW1C0
After Reset	1	0	0	0	1	0	1	0

Bit	Symbol	Bit Name	Function	R/W
b0	VW1C0	Voltage monitor 1 interrupt enable bit ⁽¹⁾	0: Disabled 1: Enabled	R/W
b1	VW1C1	Voltage monitor 1 digital filter disable mode select bit ^(2, 6)	0: Digital filter enabled mode (digital filter circuit enabled) 1: Digital filter disable mode (digital filter circuit disabled)	R/W
b2	VW1C2	Voltage change detection flag ^(3, 4)	0: Not detected 1: Vdet1 passing detected	R/W
b3	VW1C3	Voltage detection 1 signal monitor flag ⁽³⁾	0: VCC < Vdet1 1: VCC ≥ Vdet1 or voltage detection 1 circuit disabled	R
b4	VW1F0	Sampling clock select bit ⁽⁶⁾	b5 b4 0 0: fOCO-S divided by 1 0 1: fOCO-S divided by 2 1 0: fOCO-S divided by 4 1 1: fOCO-S divided by 8	R/W
b5	VW1F1			R/W
b6	—	Reserved bit	Set to 0.	R/W
b7	VW1C7	Voltage monitor 1 interrupt generation condition select bit ⁽⁵⁾	0: When VCC reaches Vdet1 or above. 1: When VCC reaches Vdet1 or below.	R/W

Notes:

- The VW1C0 is enabled when the VCA26 bit in the VCA2 register is set to 1 (voltage detection 1 circuit enabled). Set the VW1C0 bit to 0 (disabled) when the VCA26 bit is set to 0 (voltage detection 1 circuit disabled). To set the VW0C0 bit to 1 (enabled), follow the procedure shown in **Table 6.2 Procedure for Setting Bits Associated with Voltage Monitor 1 Interrupt**.
- When using the digital filter (while the VW1C1 bit is 0), set the CM14 bit in the CM1 register to 0 (low-speed on-chip oscillator on). To use the voltage monitor 1 interrupt to exit stop mode, set the VW1C1 bit in the VW1C register to 1 (digital filter disabled).
- Bits VW1C2 and VW1C3 are enabled when the VCA26 bit in the VCA2 register is set to 1 (voltage detection 1 circuit enabled).
- Set the VW1C2 bit to 0 by a program. When 0 is written by a program, this bit is set to 0 (and remains unchanged even if 1 is written to it).
- The VW1C7 bit is enabled when the VCAC1 bit in the VCAC register is set to 0 (one edge). After setting the VCAC1 bit to 0, set the VW1C7 bit.
- When the VW1C0 bit is set to 1 (enabled), do not set the VW1C1 bit and bits VW1F1 and VW1F0 simultaneously (with one instruction).

Set the PRC3 bit in the PRCR register to 1 (write enabled) before writing the VW1C register.

Rewriting the VW1C register may set the VW1C2 bit to 1. Set the VW1C2 bit to 0 after rewriting the VW1C register.

6.2.8 Voltage Monitor 2 Circuit Control Register (VW2C)

Address 003Ah

Bit	b7	b6	b5	b4	b3	b2	b1	b0
Symbol	VW2C7	—	VW2F1	VW2F0	VW2C3	VW2C2	VW2C1	VW2C0
After Reset	1	0	0	0	0	0	1	0

Bit	Symbol	Bit Name	Function	R/W
b0	VW2C0	Voltage monitor 2 interrupt enable bit ⁽¹⁾	0: Disabled 1: Enabled	R/W
b1	VW2C1	Voltage monitor 2 digital filter disable mode select bit ^(2, 6)	0: Digital filter enable mode (digital filter circuit enabled) 1: Digital filter disable mode (digital filter circuit disabled)	R/W
b2	VW2C2	Voltage change detection flag ^(3, 4)	0: Not detected 1: Vdet2 passing detected	R/W
b3	VW2C3	WDT detection monitor flag ⁽⁴⁾	0: Not detected 1: Detected	R/W
b4	VW2F0	Sampling clock select bit ⁽⁶⁾	b5 b4 0 0: fOCO-S divided by 1 0 1: fOCO-S divided by 2 1 0: fOCO-S divided by 4 1 1: fOCO-S divided by 8	R/W
b5	VW2F1			R/W
b6	—	Reserved bit	Set to 0.	R/W
b7	VW2C7	Voltage monitor 2 interrupt generation condition select bit ⁽⁵⁾	0: When VCC reaches Vdet2 or above. 1: When VCC reaches Vdet2 or below.	R/W

Notes:

- The VW2C0 is enabled when the VCA27 bit in the VCA2 register is set to 1 (voltage detection 2 circuit enabled). Set the VW2C0 bit to 0 (disabled) when the VCA27 bit is set to 0 (voltage detection 2 circuit disabled). To set the VW2C0 bit to 1 (enabled), follow the procedure shown in **Table 6.3 Procedure for Setting Bits Associated with Voltage Monitor 2 Interrupt**.
- When using the digital filter (while the VW2C1 bit is 0), set the CM14 bit in the CM1 register to 0 (low-speed on-chip oscillator on). To use the voltage monitor 2 interrupt to exit stop mode, set the VW2C1 bit in the VW2C register to 1 (digital filter disabled).
- The VW2C2 bit is enabled when the VCA27 bit in the VCA2 register is set to 1 (voltage detection 2 circuit enabled).
- Set this bit to 0 by a program. When 0 is written by a program, this bit is set to 0 (and remains unchanged even if 1 is written to it).
- The VW2C7 bit is enabled when the VCAC2 bit in the VCAC register is set to 0 (one edge). After setting the VCAC2 bit to 0, set the VW2C7 bit.
- When the VW2C0 bit is set to 1 (enabled), do not set the VW2C1 bit and bits VW2F1 and VW2F0 simultaneously (with one instruction).

Set the PRC3 bit in the PRCR register to 1 (write enabled) before rewriting the VW2C register.

Rewriting the VW2C register may set the VW2C2 bit to 1. After rewriting this register, set the VW2C2 bit to 0.

6.2.9 Option Function Select Register (OFS)

Address 0FFFFh

Bit	b7	b6	b5	b4	b3	b2	b1	b0
Symbol	CSPROINI	LVDAS	—	—	ROMCP1	ROMCR	—	WDTON
After Reset	User Setting Value ⁽¹⁾							

Bit	Symbol	Bit Name	Function	R/W
b0	WDTON	Watchdog timer start select bit	0: Watchdog timer automatically starts after reset 1: Watchdog timer is stopped after reset	R/W
b1	—	Reserved bit	Set to 1.	R/W
b2	ROMCR	ROM code protect disable bit	0: ROM code protect disabled 1: ROMCP1 bit enabled	R/W
b3	ROMCP1	ROM code protect bit	0: ROM code protect enabled 1: ROM code protect disabled	R/W
b4	—	Reserved bit	Set to 1.	R/W
b5	—	Reserved bit	Set to 0.	R/W
b6	LVDAS	Voltage detection 0 circuit start bit ⁽²⁾	0: Voltage monitor 0 reset enabled after reset 1: Voltage monitor 0 reset disabled after reset	R/W
b7	CSPROINI	Count source protection mode after reset select bit	0: Count source protect mode enabled after reset 1: Count source protect mode disabled after reset	R/W

Notes:

- The OFS register is allocated in the flash memory, not in the SFRs. Set appropriate values as ROM data by a program.
Do not write additions to the OFS register. If the block including the OFS register is erased, the OFS register is set to FFh.
When blank products are shipped, the OFS register is set to FFh. It is set to the written value after written by the user.
When factory-programming products are shipped, the value of the OFS register is the value programmed by the user.
- To use power-on reset and voltage monitor 0 reset, set the LVDAS bit to 0 (voltage monitor 0 reset enabled after reset).

For a setting example of the OFS register, refer to **13.3.1 Setting Example of Option Function Select Area**.

6.3 VCC Input Voltage

6.3.1 Monitoring Vdet0

Vdet0 cannot be monitored.

6.3.2 Monitoring Vdet1

Once the following settings are made, the comparison result of voltage monitor 1 can be monitored by the VW1C3 bit in the VW1C register after $t_d(E-A)$ has elapsed (refer to **30. Electrical Characteristics**).

- (1) Set bits VD1S3 to VD1S0 in the VD1LS register (voltage detection 1 detection voltage).
- (2) Set the VCA26 bit in the VCA2 register to 1 (voltage detection 1 circuit enabled).

6.3.3 Monitoring Vdet2

Once the following settings are made, the comparison result of voltage monitor 2 can be monitored by the VCA13 bit in the VCA1 register after $t_d(E-A)$ has elapsed (refer to **30. Electrical Characteristics**).

- Set the VCA27 bit in the VCA2 register to 1 (voltage detection 2 circuit enabled).

6.4 Voltage Monitor 0 Reset

To use voltage monitor 0 reset, set the LVDAS bit in the OFS register to 0 (voltage monitor 0 reset enabled after reset).

Figure 6.5 shows an Operating Example of Voltage Monitor 0 Reset.

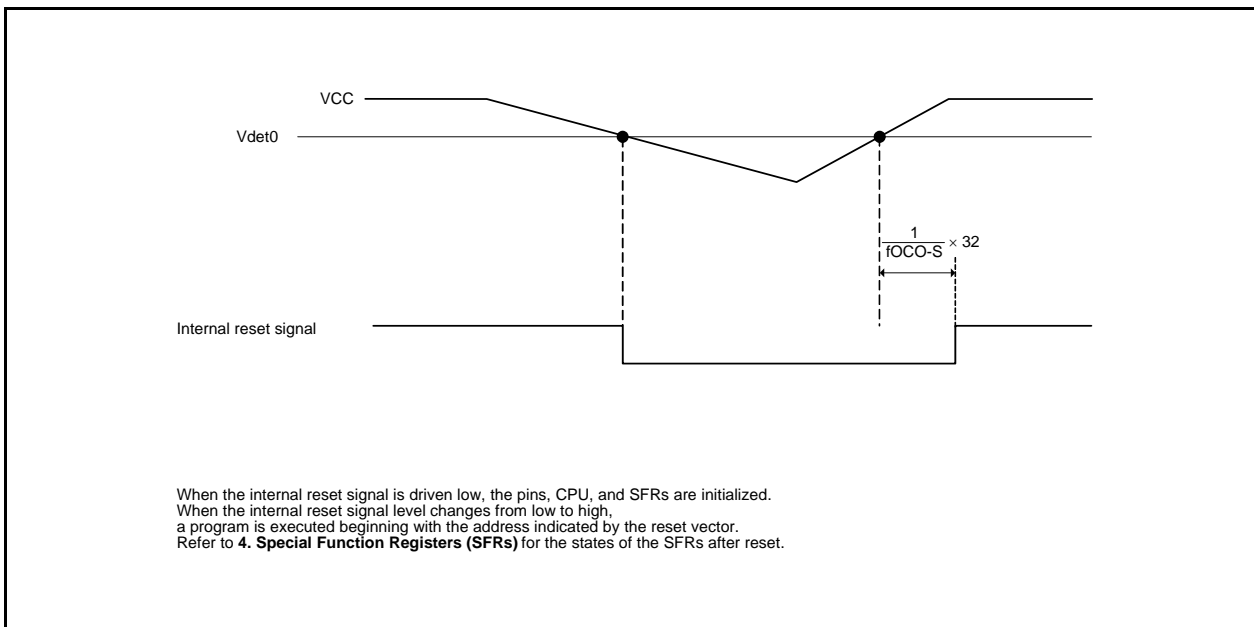

Figure 6.5 Operating Example of Voltage Monitor 0 Reset

6.5 Voltage Monitor 1 Interrupt

Table 6.2 lists the Procedure for Setting Bits Associated with Voltage Monitor 1 Interrupt. Figure 6.6 shows an Operating Example of Voltage Monitor 1 Interrupt.

To use the voltage monitor 1 interrupt to exit stop mode, set the VW1C1 bit in the VW1C register to 1 (digital filter disabled).

Table 6.2 Procedure for Setting Bits Associated with Voltage Monitor 1 Interrupt

Step	When Using Digital Filter	When Using No Digital Filter
1	Select the voltage detection 1 detection voltage by bits VD1S3 to VD1S0 in the VD1LS register.	
2	Set the VCA26 bit in the VCA2 register to 1 (voltage detection 1 circuit enabled).	
3	Wait for td(E-A).	
4	Set the COMPSEL bit in the CMPA register to 1.	
5 (1)	Select the interrupt type by the IRQ1SEL in the CMPA register.	
6	Select the sampling clock of the digital filter by bits VW1F0 and VW1F1 in the VW1C register.	Set the VW1C1 bit in the VW1C register to 1 (digital filter disabled).
7 (2)	Set the VW1C1 bit in the VW1C register to 0 (digital filter enabled).	–
8	Select the interrupt request timing by the VCAC1 bit in the VCAC register and the VW1C7 bit in the VW1C register.	
9	Set the VW1C2 bit in the VW1C register to 0.	
10	Set the CM14 bit in the CM1 register to 0 (low-speed on-chip oscillator on)	–
11	Wait for 2 cycles of the sampling clock of the digital filter	– (No wait time required)
12 (3)	Set the VW1C0 bit in the VW1C register to 1 (voltage monitor 1 interrupt enabled)	

Notes:

- When the VW1C0 bit is set to 0, steps 4 and 5 can be executed simultaneously (with one instruction).
- When the VW1C0 bit is set to 0, steps 6 and 7 can be executed simultaneously (with one instruction).
- When the voltage detection 1 circuit is enabled while the voltage monitor 1 interrupt is disabled, low voltage is detected and the VW1C2 bit becomes 1.
When low voltage is detected after the voltage detection 1 circuit is enabled until an interrupt is enabled for the setting procedure of bits associated with voltage monitor 1 interrupt, an interrupt is not generated. After an interrupt is enabled, read the VW1C2 bit. When the bit is read as 1, perform the process that occurs when low voltage is detected.

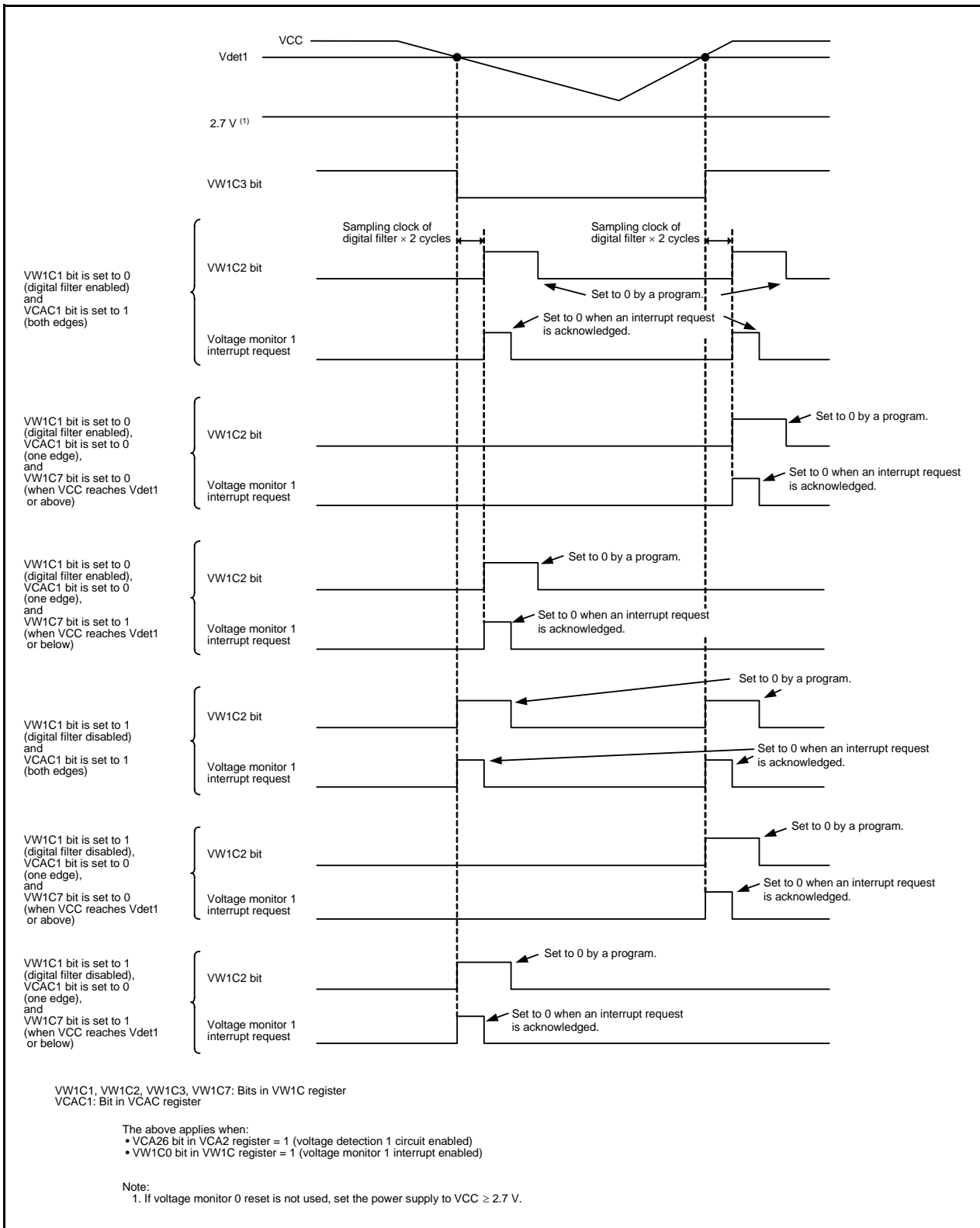

Figure 6.6 Operating Example of Voltage Monitor 1 Interrupt

6.6 Voltage Monitor 2 Interrupt

Table 6.3 lists the Procedure for Setting Bits Associated with Voltage Monitor 2 Interrupt. Figure 6.7 shows an Operating Example of Voltage Monitor 2 Interrupt.

To use the voltage monitor 2 interrupt to exit stop mode, set the VW2C1 bit in the VW2C register to 1 (digital filter disabled).

Table 6.3 Procedure for Setting Bits Associated with Voltage Monitor 2 Interrupt

Step	When Using Digital Filter	When Using No Digital Filter
1	Set the VCA27 bit in the VCA2 register to 1 (voltage detection 2 circuit enabled).	
2	Wait for $t_d(E-A)$.	
3	Set the COMPSEL bit in the CMPA register to 1.	
4 (1)	Select the interrupt type by the IRQ2SEL in the CMPA register.	
5	Select the sampling clock of the digital filter by bits VW2F0 and VW2F1 in the VW2C register.	Set the VW2C1 bit in the VW2C register to 1 (digital filter disabled).
6 (2)	Set the VW2C1 bit in the VW2C register to 0 (digital filter enabled).	–
7	Select the interrupt request timing by the VCAC2 bit in the VCAC register and the VW2C7 bit in the VW2C register.	
8	Set the VW2C2 bit in the VW2C register to 0.	
9	Set the CM14 bit in the CM1 register to 0 (low-speed on-chip oscillator on).	–
10	Wait for 2 cycles of the sampling clock of the digital filter.	– (No wait time required)
11 (3)	Set the VW2C0 bit in the VW2C register to 1 (voltage monitor 2 interrupt enabled).	

Notes:

1. When the VW2C0 bit is set to 0, steps 3 and 4 can be executed simultaneously (with one instruction).
2. When the VW2C0 bit is set to 0, steps 5 and 6 can be executed simultaneously (with one instruction).
3. When the voltage detection 2 circuit is enabled while the voltage monitor 2 interrupt is disabled, low voltage is detected and the VW2C2 bit becomes 1.

When low voltage is detected after the voltage detection 2 circuit is enabled until an interrupt is enabled for the setting procedure of bits associated with voltage monitor 2 interrupt, an interrupt is not generated. After an interrupt is enabled, read the VW2C2 bit. When the bit is read as 1, perform the process that occurs when low voltage is detected.

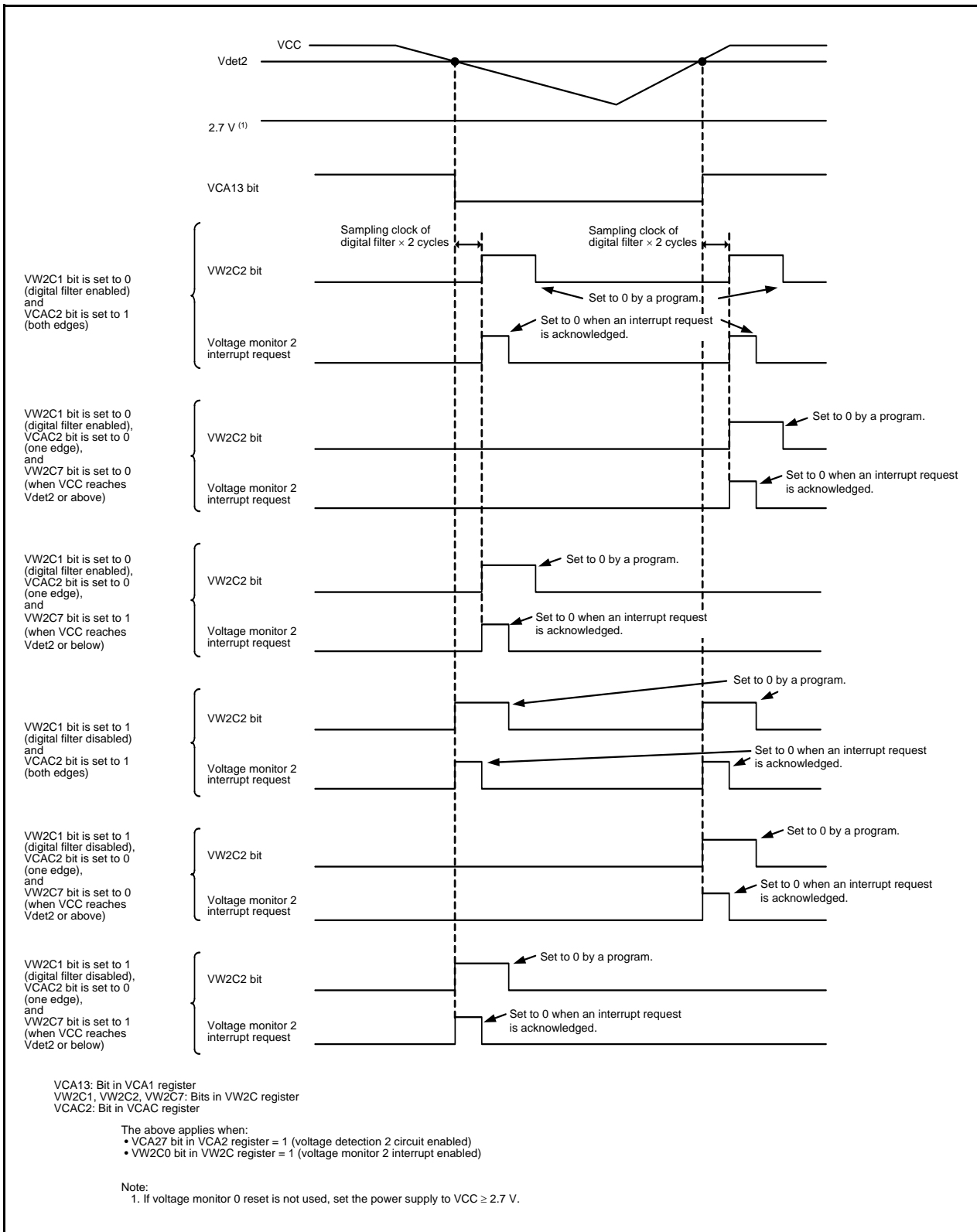

Figure 6.7 Operating Example of Voltage Monitor 2 Interrupt

7. I/O Ports

There are 27 I/O ports P0 to P1, P3_1, P3_3 to P3_7, P4_5 to P4_7, P5_3 and P5_4 (P4_6 and P4_7 can be used as I/O ports if the XIN clock oscillation circuit is not used.).

If the A/D converter and the D/A converter are not used, P4_2 can be used as an input-only port.

Table 7.1 lists an Overview of I/O Ports.

Table 7.1 Overview of I/O Ports

Ports	I/O	Type of Output	I/O Setting	Internal Pull-Up Resistor	Input Level Switch
P0	I/O	CMOS3 state	Set in 1-bit units	Set in 4-bit units (1)	Set in 8-bit units (2)
P1	I/O	CMOS3 state	Set in 1-bit units	Set in 4-bit units (1)	Set in 8-bit units (2)
P3_1, P3_3	I/O	CMOS3 state	Set in 1-bit units	Set in 2-bit units (1)	Set in 6-bit units (2)
P3_4 to P3_7	I/O	CMOS3 state	Set in 1-bit units	Set in 4-bit units (1)	
P4_5, P4_6 (3), P4_7 (3)	I/O	CMOS3 state	Set in 1-bit units	Set in 3-bit units (1)	Set in 4-bit units (2)
P4_2 (4)	I	(No output function)	None	None	
P5_3, P5_4	I/O	CMOS3 state	Set in 1-bit units	Set in 1-bit unit (1)	Set in 2-bit units (2)

Notes:

1. In input mode, whether an internal pull-up resistor is connected or not can be selected by registers PUR0 and PUR1.
2. The input threshold value can be selected among three voltage levels (0.35 VCC, 0.50 VCC, and 0.70 VCC) using registers VLT0 and VLT1.
3. When the XIN clock oscillation circuit is not used, these ports can be used as I/O ports.
4. When the A/D converter and the D/A converter are not used, this port can be used as an input-only ports.

7.1 Functions of I/O Ports

The PDi_j (j = 0 to 7) bit in the PDi (i = 0 to 1, 3 to 5) register controls I/O of the ports P0 to P1, P3_1, P3_3 to P3_7, P4_5 to P4_7, P5_3 and P5_4. The Pi register consists of a port latch to hold output data and a circuit to read pin states.

Figures 7.1 to 7.13 show the Configurations of I/O Ports. Table 7.2 lists the Functions of I/O Ports.

Table 7.2 Functions of I/O Ports

Operation When Accessing Pi Register	Value of PDi_j Bit in PDi Register (1)	
	When PDi_j Bit is Set to 0 (Input Mode)	When PDi_j Bit is Set to 1 (Output Mode)
Read	Read the pin input level.	Read the port latch.
Write	Write to the port latch.	Write to the port latch. The value written to the port latch is output from the pin.

i = 0 to 1, 3 to 5, j = 0 to 7

Note:

1. Nothing is assigned to bits PD3_2, PD4_0 to PD4_2, PD5_0 to PD5_2, and PD5_5 to PD5_7. Also, bits PD3_0, PD4_3 and PD4_4 are reserved bits.

7.2 Effect on Peripheral Functions

I/O ports function as I/O ports for peripheral functions (refer to **Table 1.7 Pin Name Information by Pin Number**).

Table 7.3 lists the Setting of PDi_j Bit when Functioning as I/O Ports for Peripheral Functions (i = 0 to 1, 3 to 5, j = 0 to 7).

Refer to the description of each function for information on how to set peripheral functions.

**Table 7.3 Setting of PDi_j Bit when Functioning as I/O Ports for Peripheral Functions
(i = 0 to 1, 3 to 5, j = 0 to 7)**

I/O of Peripheral Function	PDi_j Bit Settings for Shared Pin Function
Input	Set this bit to 0 (input mode).
Output	This bit can be set to either 0 or 1 (output regardless of the port setting).

7.3 Pins Other than I/O Ports

Figure 7.13 shows the Configuration of I/O Pins.

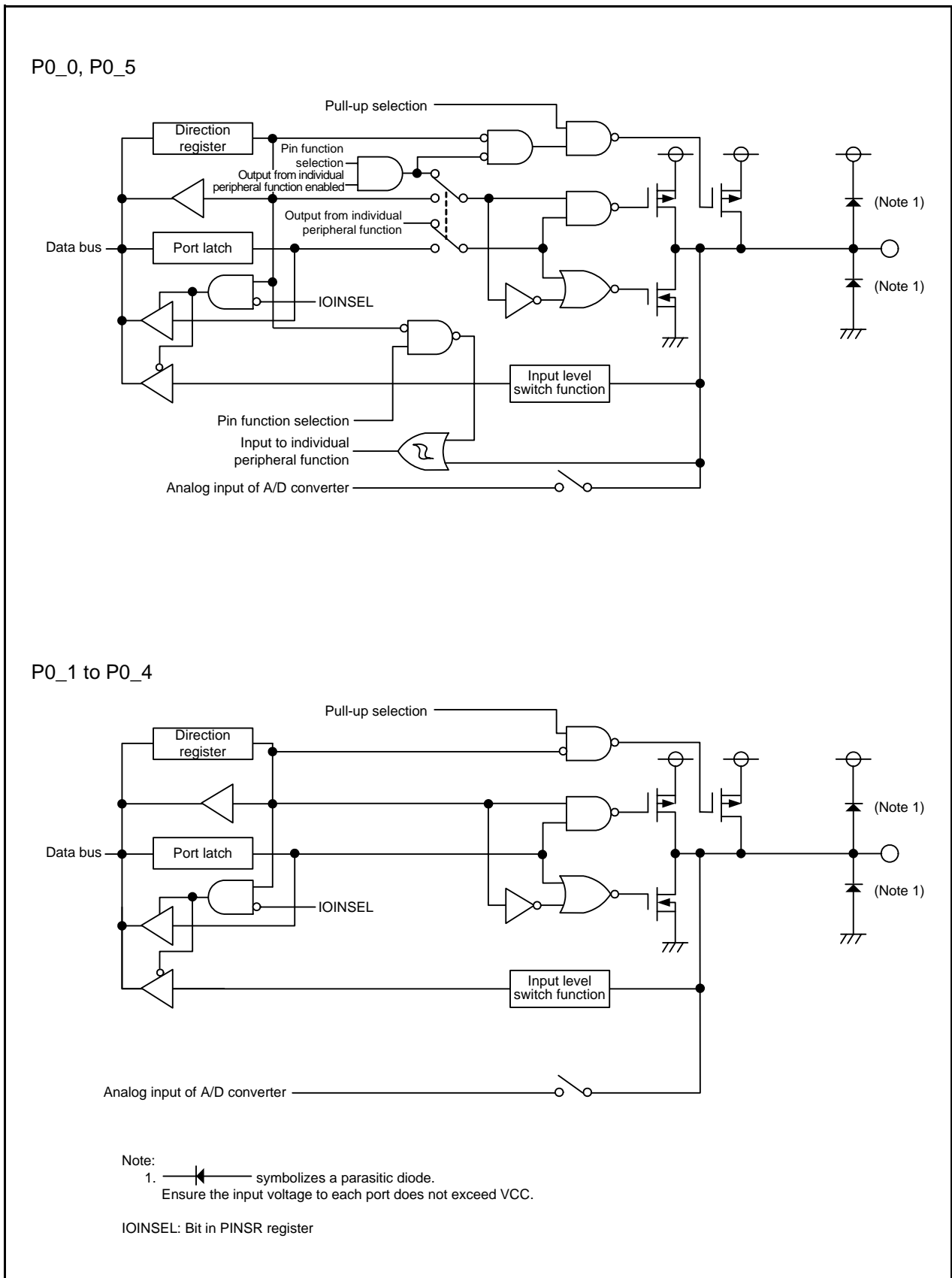

Figure 7.1 Configuration of I/O Ports (1)

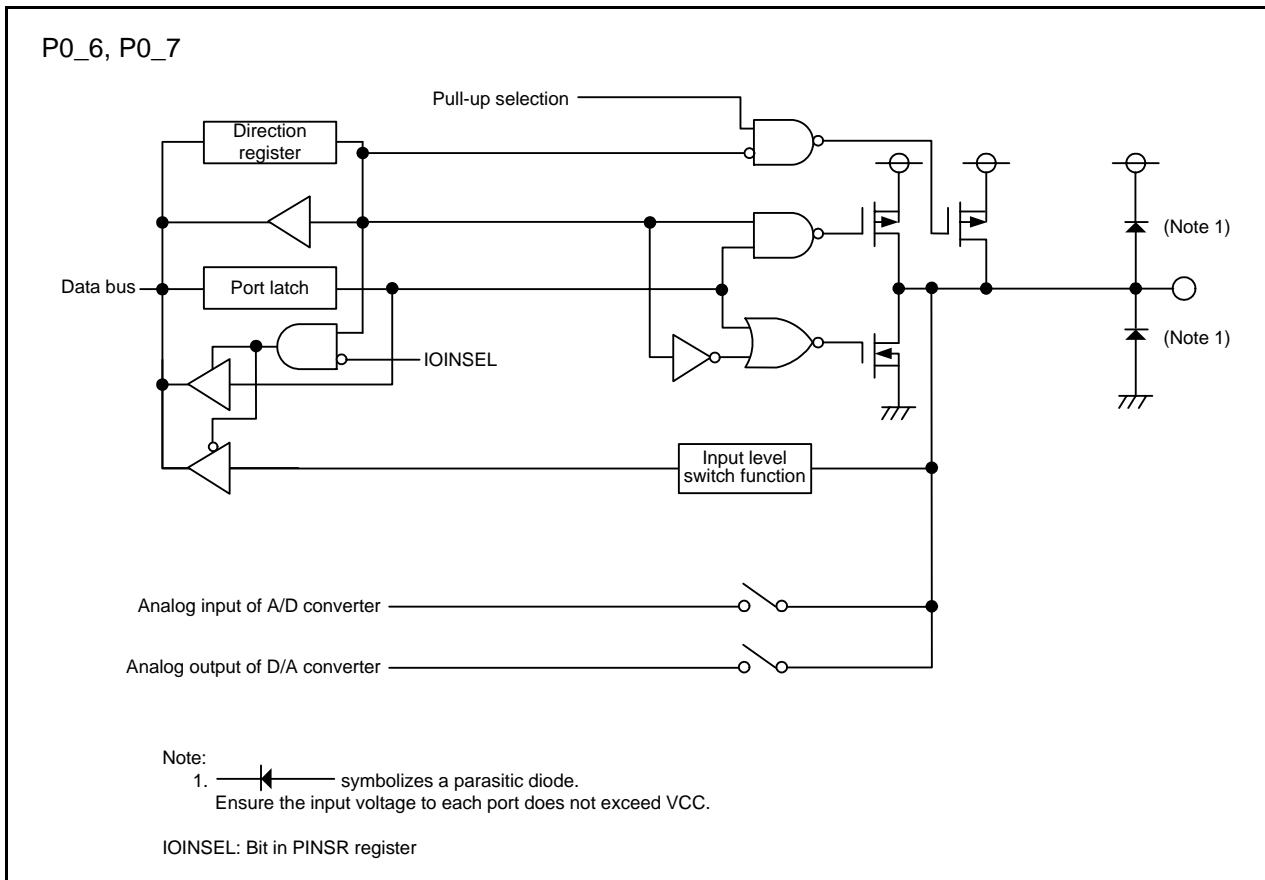

Figure 7.2 Configuration of I/O Ports (2)

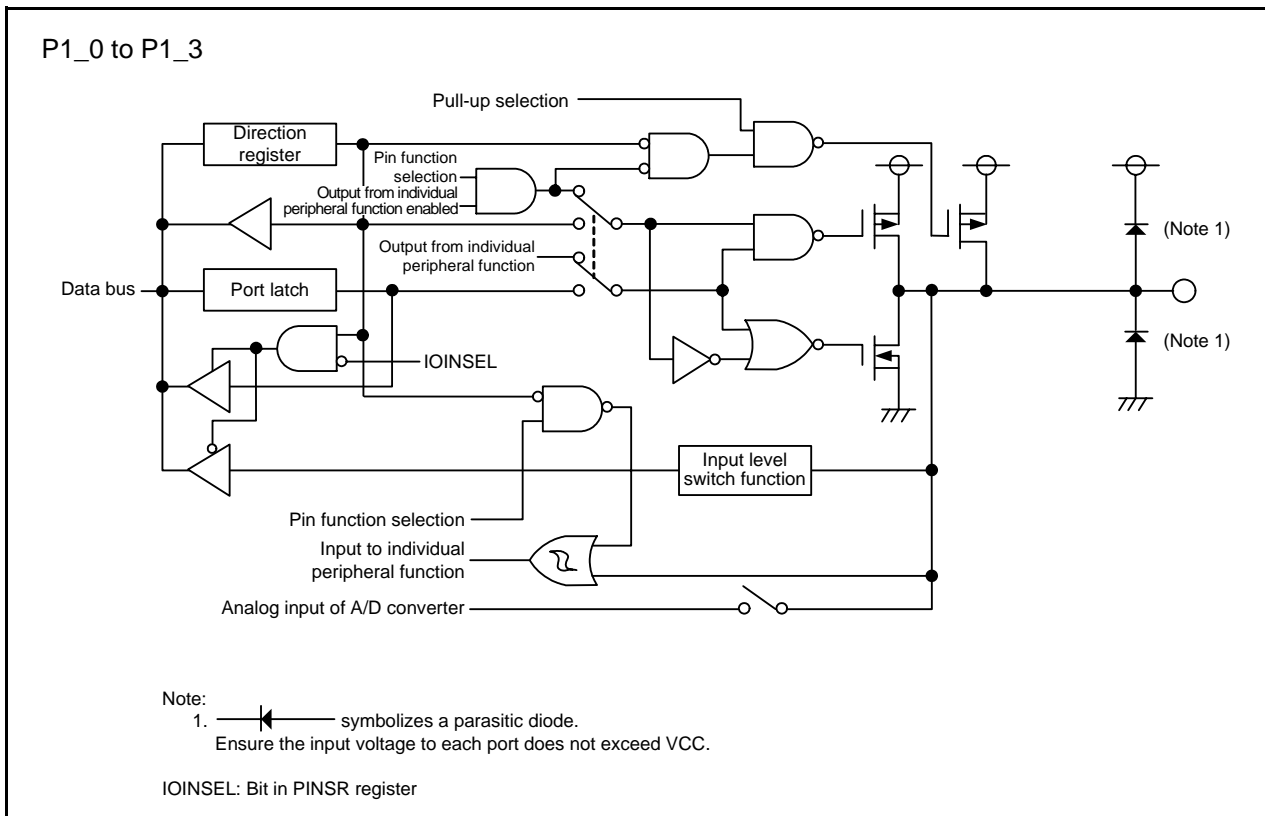

Figure 7.3 Configuration of I/O Ports (3)

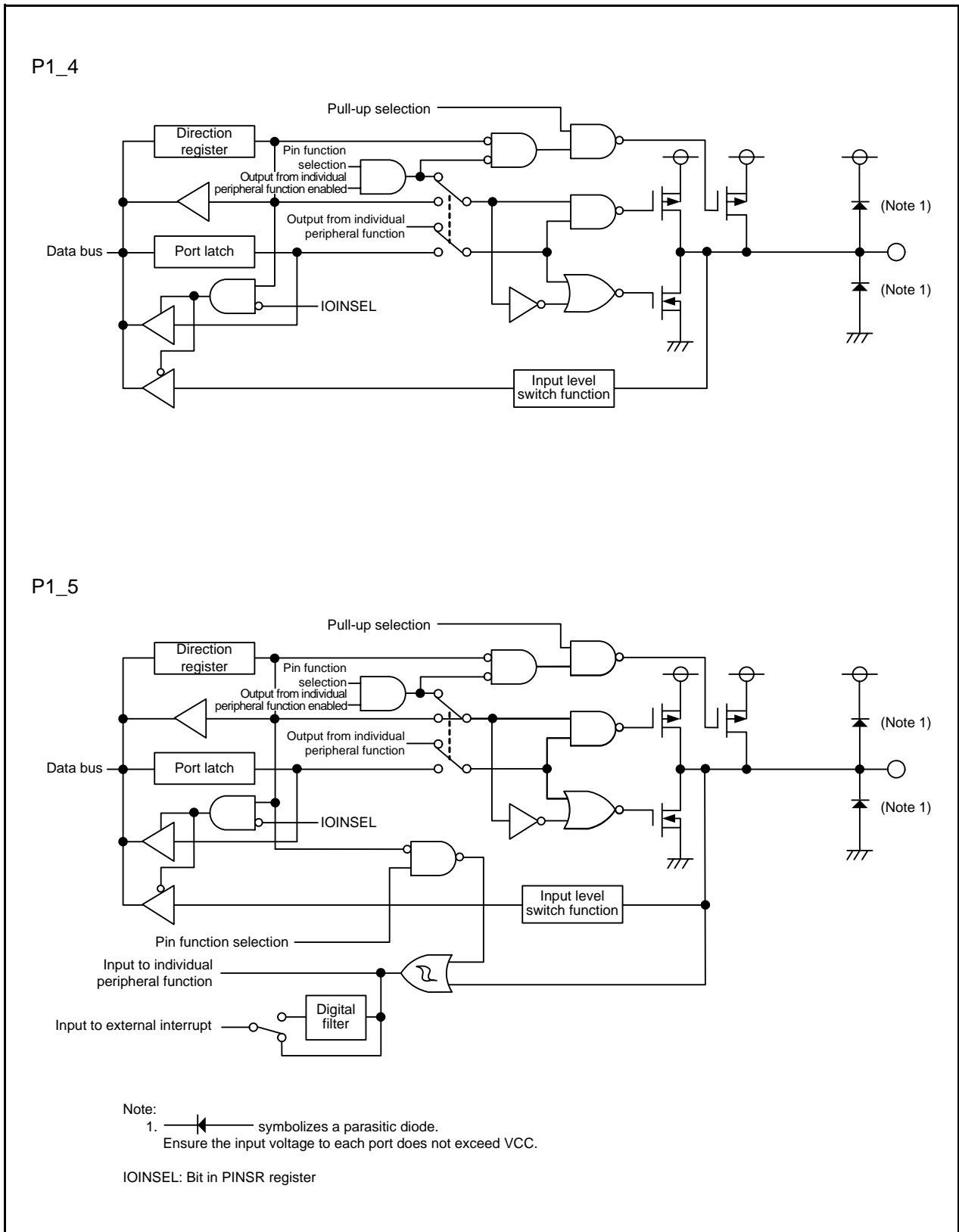

Figure 7.4 Configuration of I/O Ports (4)

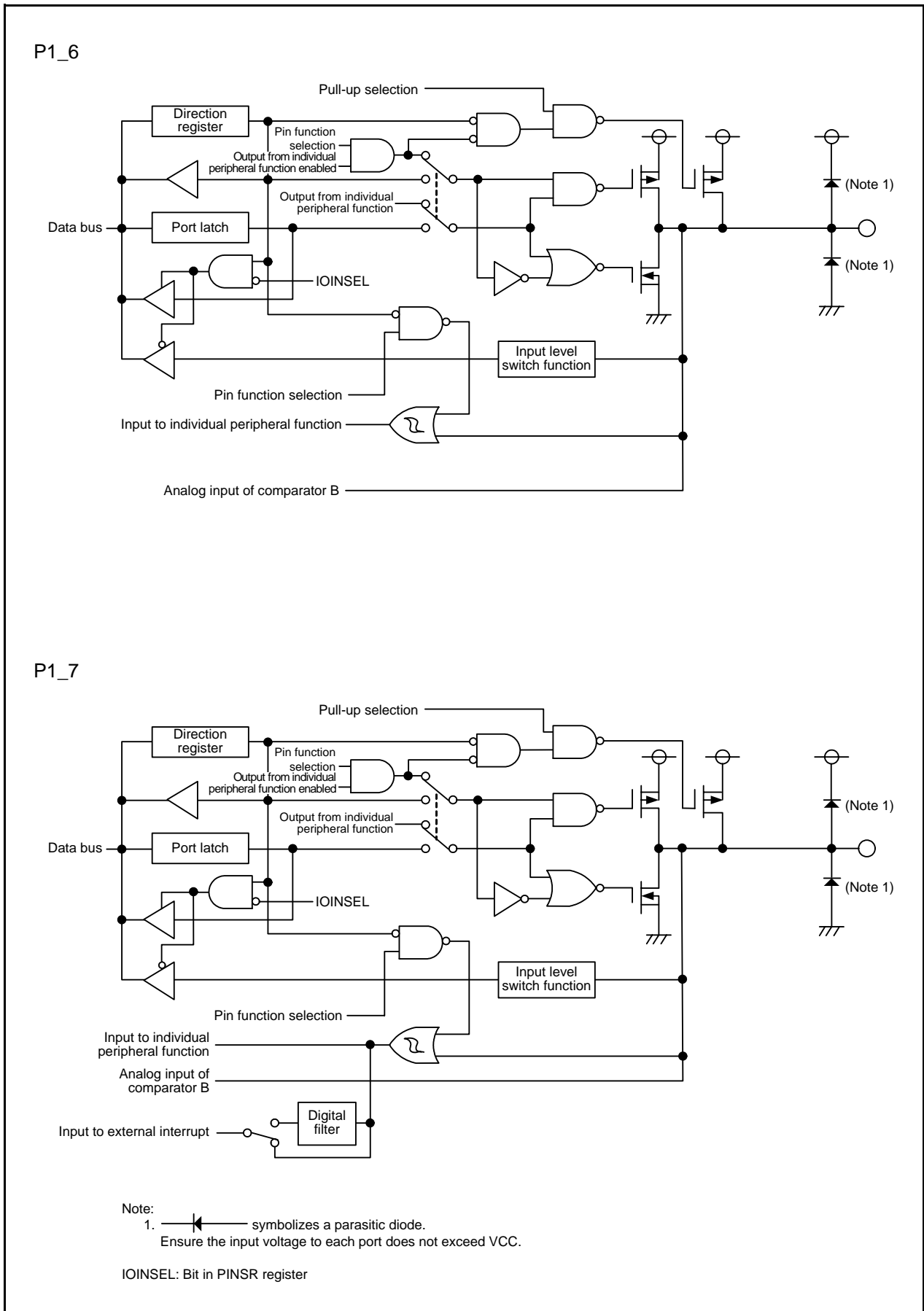

Figure 7.5 Configuration of I/O Ports (5)

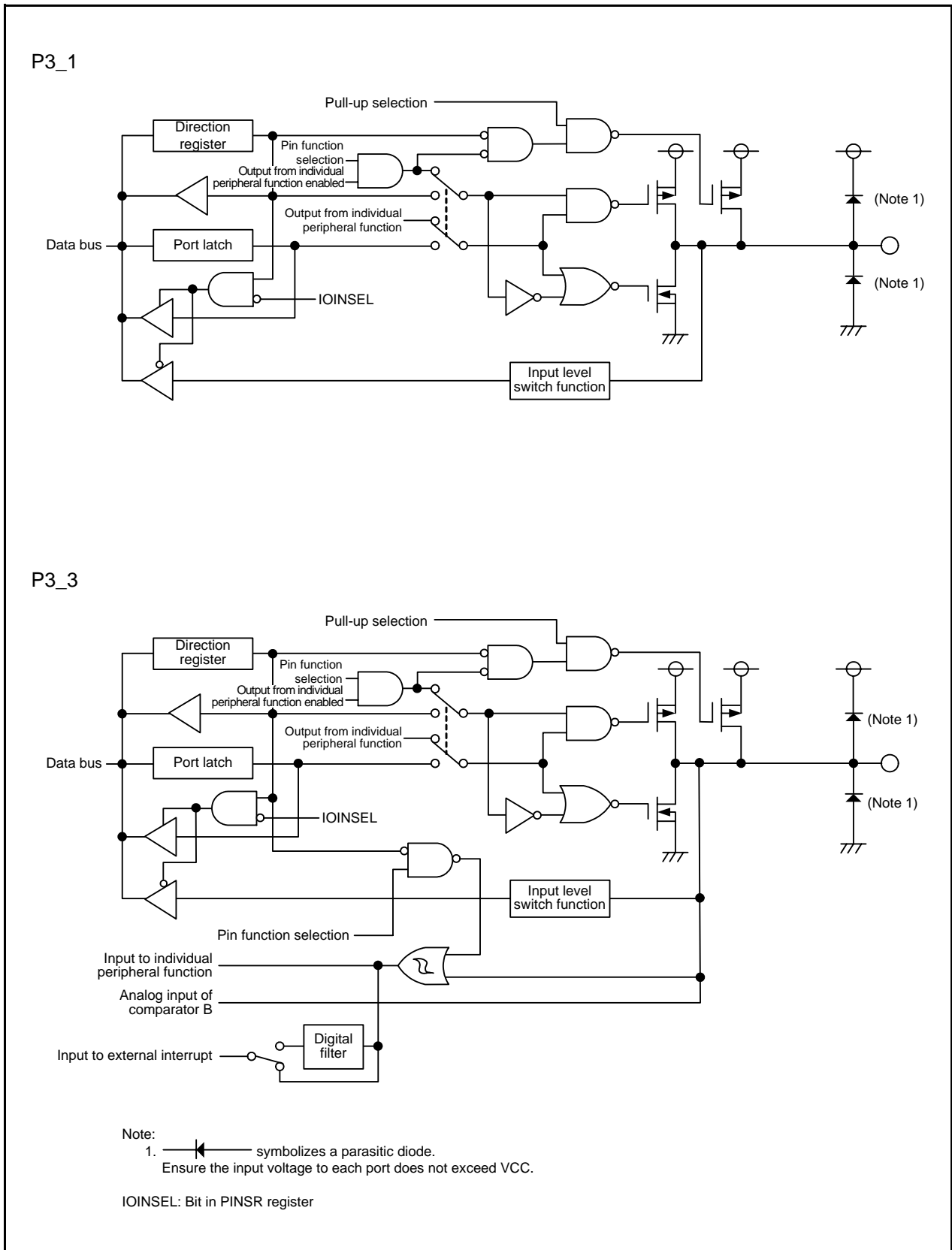

Figure 7.6 Configuration of I/O Ports (6)

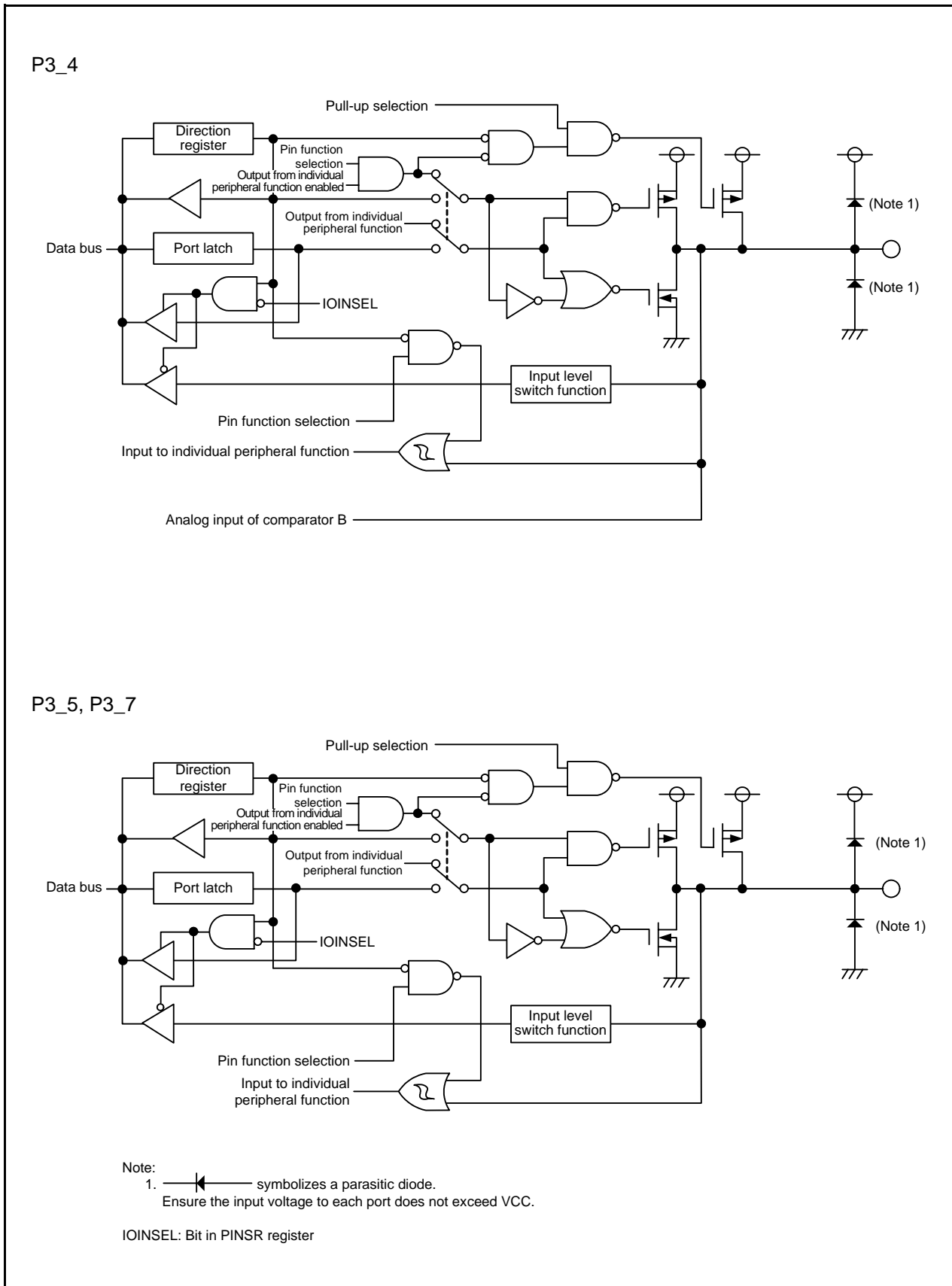

Figure 7.7 Configuration of I/O Ports (7)

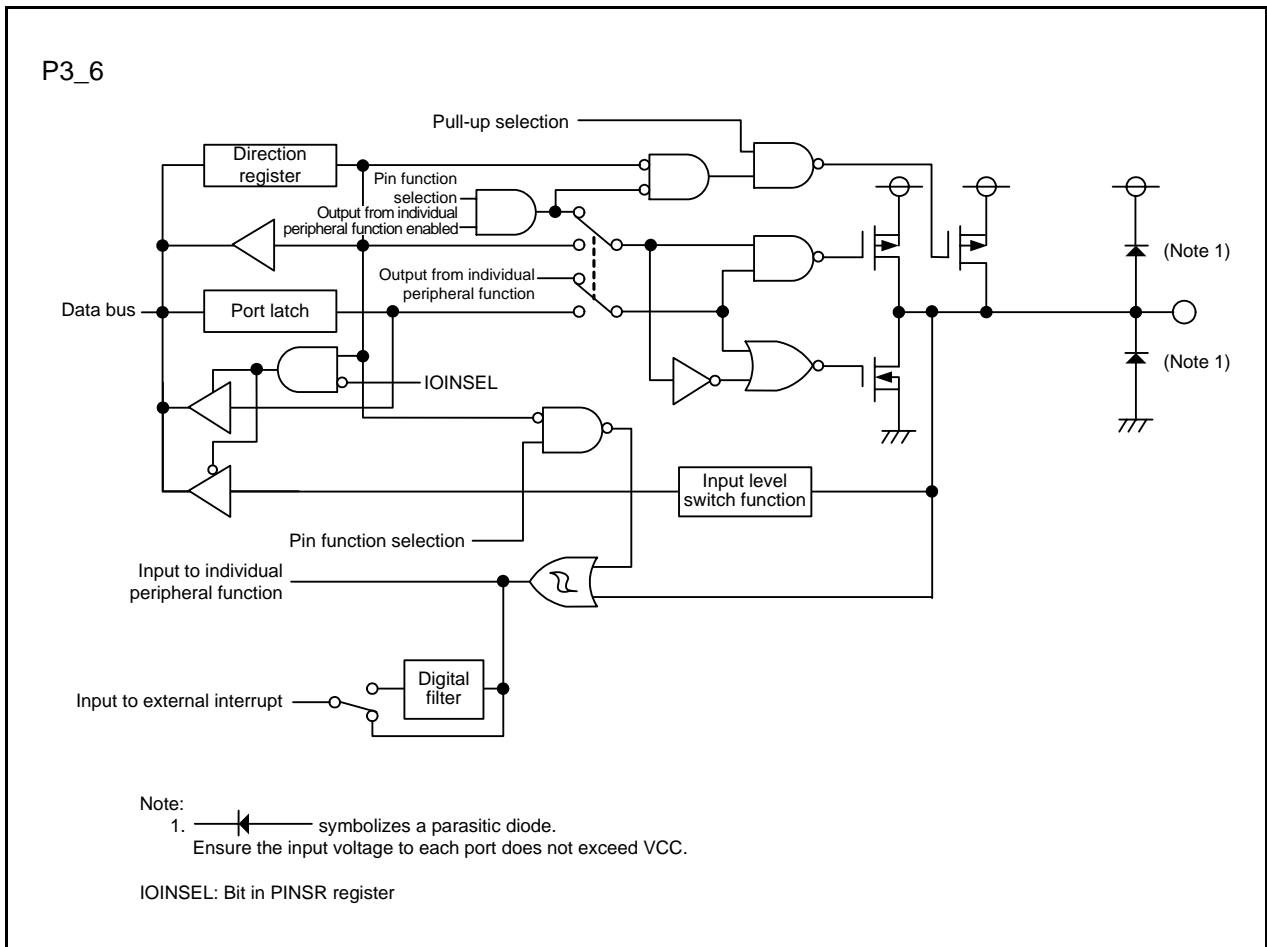

Figure 7.8 Configuration of I/O Ports (8)

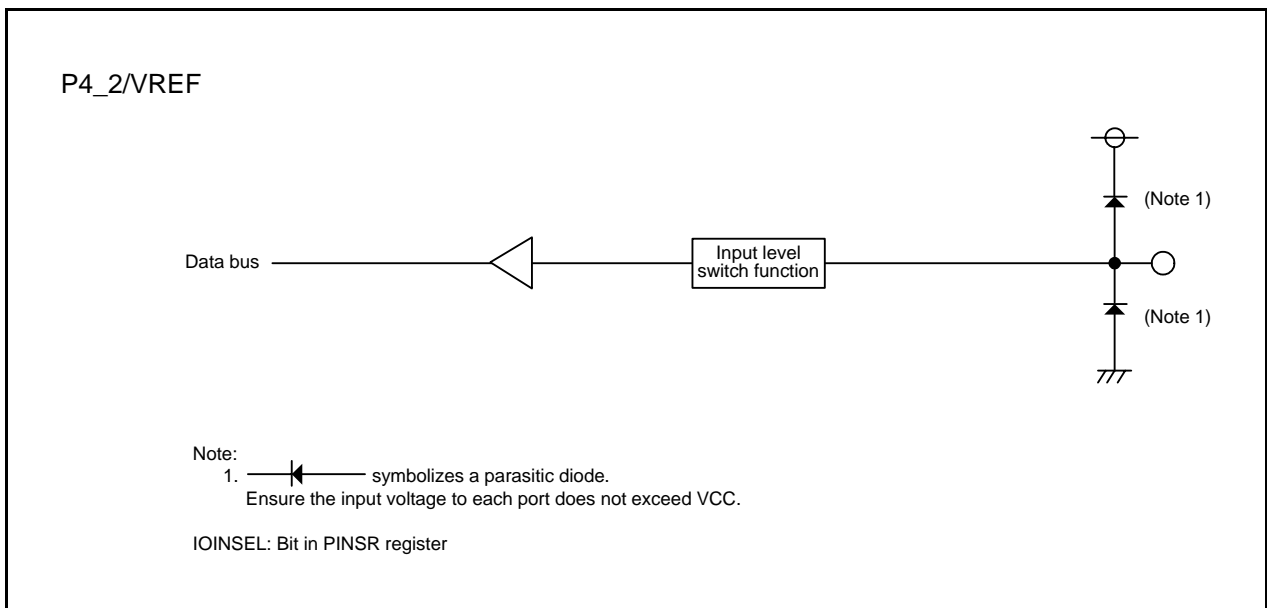

Figure 7.9 Configuration of I/O Ports (9)

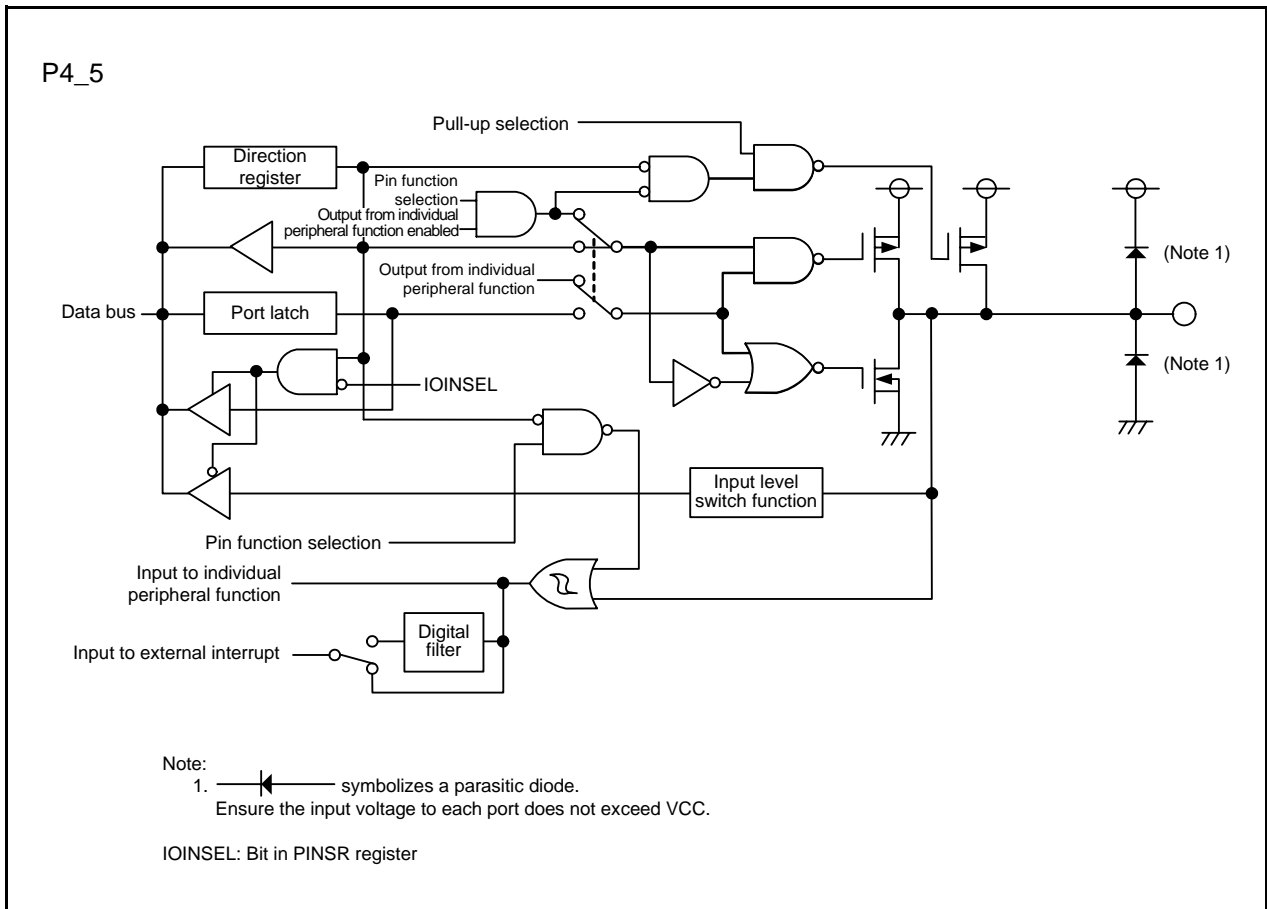

Figure 7.10 Configuration of I/O Ports (10)

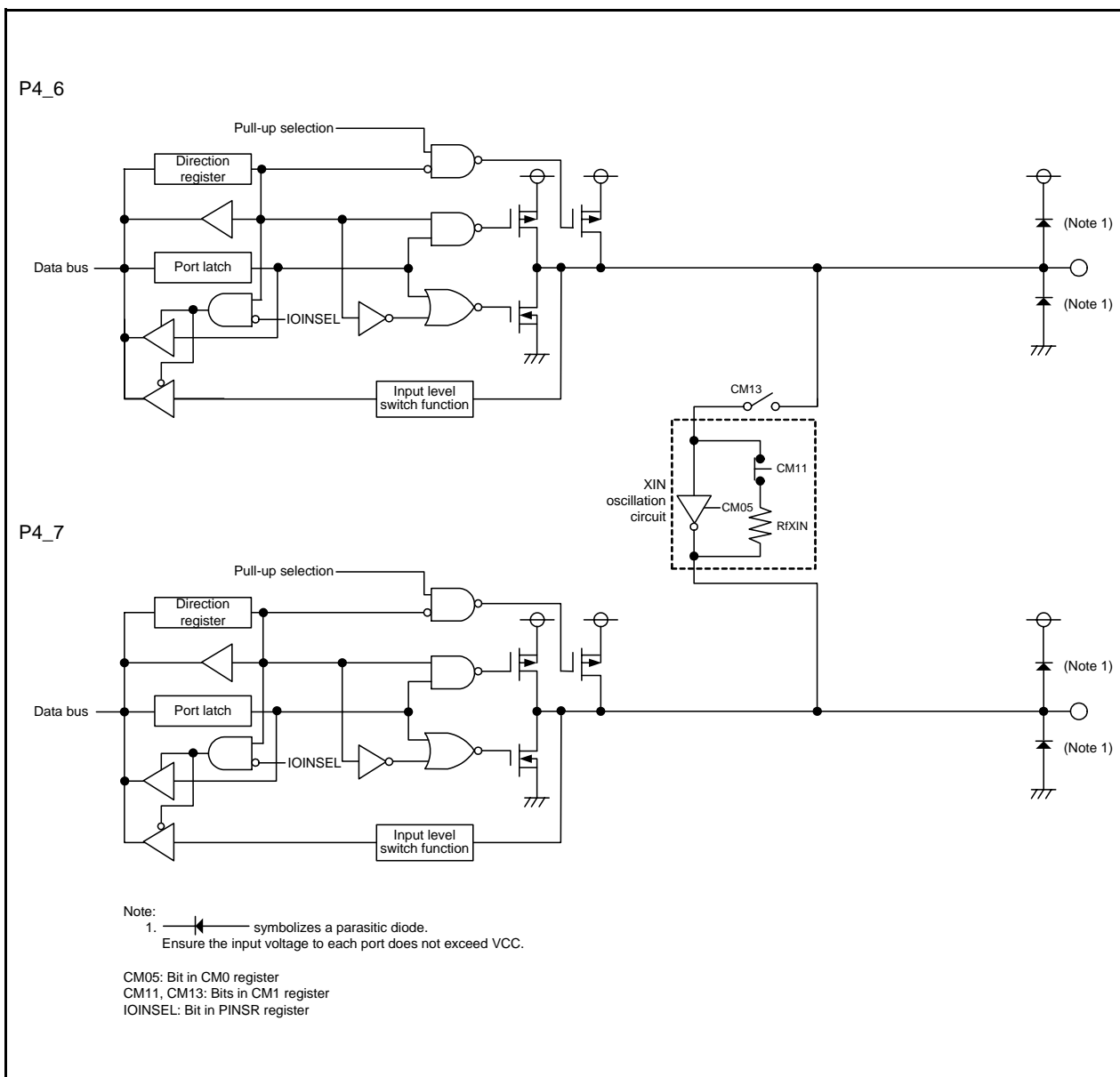

Figure 7.11 Configuration of I/O Ports (11)

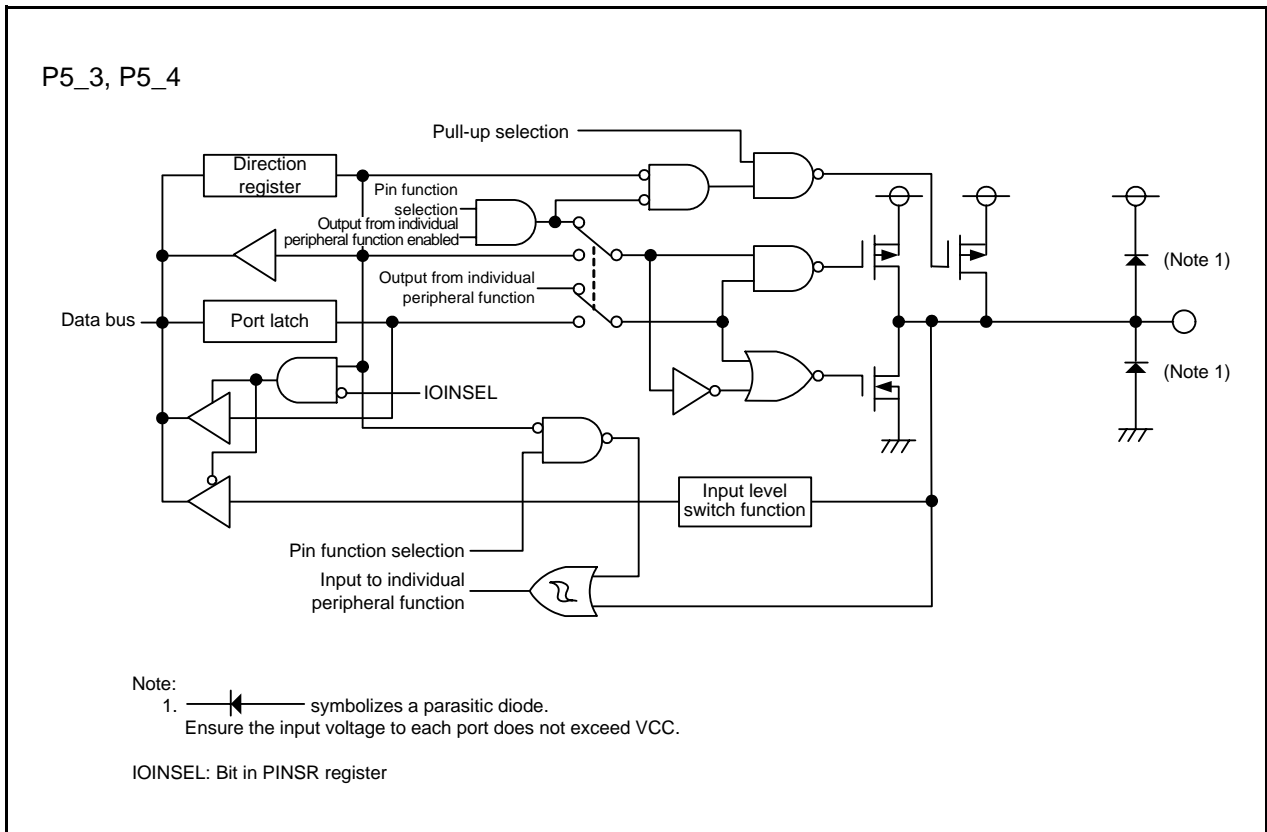

Figure 7.12 Configuration of I/O Ports (12)

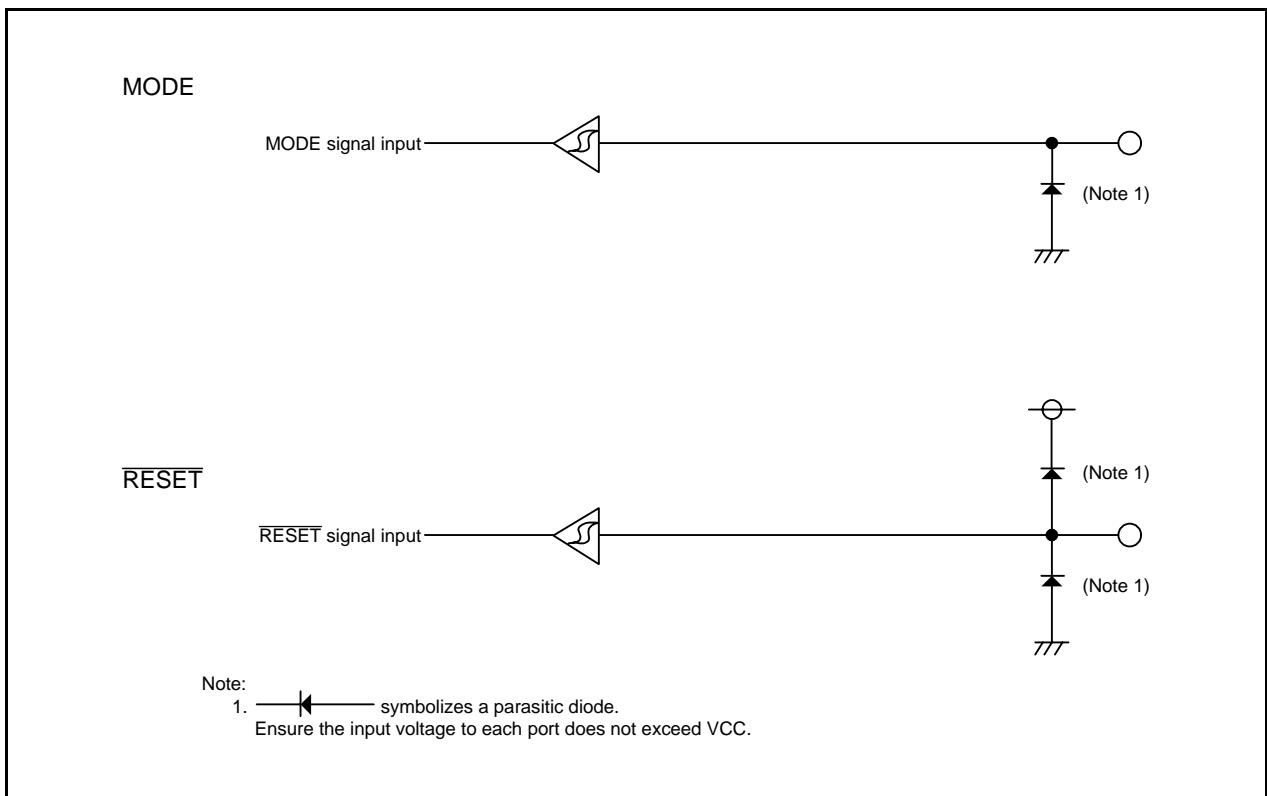

Figure 7.13 Configuration of I/O Pins

7.4 Registers

7.4.1 Port Pi Direction Register (PDi) (i = 0 to 1, 3 to 5)

Address 00E2h (PD0 ⁽¹⁾), 00E3h (PD1), 00E7h (PD3 ⁽²⁾, ⁽³⁾), 00EAh (PD4 ⁽²⁾, ⁽³⁾), 00EBh (PD5 ⁽²⁾)

Bit	b7	b6	b5	b4	b3	b2	b1	b0
Symbol	PDi_7	PDi_6	PDi_5	PDi_4	PDi_3	PDi_2	PDi_1	PDi_0
After Reset	0	0	0	0	0	0	0	0

Bit	Symbol	Bit Name	Function	R/W
b0	PDi_0	Port Pi_0 direction bit	0: Input mode (functions as an input port) 1: Output mode (functions as an output port)	R/W
b1	PDi_1	Port Pi_1 direction bit		R/W
b2	PDi_2	Port Pi_2 direction bit		R/W
b3	PDi_3	Port Pi_3 direction bit		R/W
b4	PDi_4	Port Pi_4 direction bit		R/W
b5	PDi_5	Port Pi_5 direction bit		R/W
b6	PDi_6	Port Pi_6 direction bit		R/W
b7	PDi_7	Port Pi_7 direction bit		R/W

Notes:

1. Write to the PD0 register with the next instruction after that used to set the PRC2 bit in the PRCR register to 1 (write enabled).
2. Bit PD3_2 in the PD3 register, bits PD4_0 to PD4_2 in the PD4 register, and bits PD5_0 to PD5_2 and PD5_5 to PD5_7 in the PD5 register are unavailable on this MCU. If it is necessary to set bits PD3_2, PD4_0 to PD4_2, PD5_0 to PD5_2, and PD5_5 to PD5_7 set to 0. When read, the content is 0.
3. Bits PD3_0, PD4_3 to PD4_4 in the PD3 register are reserved bits. If it is necessary to set bits PD3_0, PD4_3 to PD4_4, set to 0. When read, the content is 0.

The PDi register selects whether I/O ports are used for input or output. Each bit in the PDi register corresponds to one port.

7.4.2 Port Pi Register (Pi) (i = 0 to 1, 3 to 5)

Address 00E0h(P0), 00E1h(P1), 00E5h(P3 ⁽¹⁾), 00E8h(P4 ⁽¹⁾), 00E9h(P5 ⁽²⁾)

Bit	b7	b6	b5	b4	b3	b2	b1	b0
Symbol	Pi_7	Pi_6	Pi_5	Pi_4	Pi_3	Pi_2	Pi_1	Pi_0
After Reset	X	X	X	X	X	X	X	X

Bit	Symbol	Bit Name	Function	R/W
b0	Pi_0	Port Pi_0 bit	0: "L" level 1: "H" level	R/W
b1	Pi_1	Port Pi_1 bit		R/W
b2	Pi_2	Port Pi_2 bit		R/W
b3	Pi_3	Port Pi_3 bit		R/W
b4	Pi_4	Port Pi_4 bit		R/W
b5	Pi_5	Port Pi_5 bit		R/W
b6	Pi_6	Port Pi_6 bit		R/W
b7	Pi_7	Port Pi_7 bit		R/W

Notes:

1. Bit P3_2 in the P3 register, bits P4_0 to P4_1 in the P4 register are unavailable on this MCU. If it is necessary to set bits P3_2, P4_0 to P4_1 set to 0. When read, the content is 0.
Also, bits P3_0 in the P3 register, P4_3 to P4_4 are reserved bits. If it is necessary to set bits P3_0, P4_3 to P4_4, set to 0. When read, the content is undefined.
2. Bits P5_0 to P5_2, and P5_5 to P5_7 in the P5 register are unavailable on this MCU. If it is necessary to set bits P5_0 to P5_2, and P5_5 to P5_7, set to 0. When read, the content is 0.

Data input and output to and from external devices are accomplished by reading and writing to the Pi register. The Pi register consists of a port latch to retain output data and a circuit to read the pin status. The value written in the port latch is output from the pin. Each bit in the Pi register corresponds to one port.

Pi_j Bit (i = 0 to 1, 3 to 5, j = 0 to 7) (Port Pi_j Bit)

The pin level of any I/O port which is set to input mode can be read by reading the corresponding bit in this register. The pin level of any I/O port which is set to output mode can be controlled by writing to the corresponding bit in this register.

7.4.3 Timer RA Pin Select Register (TRASR)

Address 0180h

Bit	b7	b6	b5	b4	b3	b2	b1	b0
Symbol	—	—	—	—	—	—	TRAIOSSEL1	TRAIOSSEL0
After Reset	0	0	0	0	0	0	0	0

Bit	Symbol	Bit Name	Function	R/W
b0	TRAIOSSEL0	TRAI0 pin select bit	^{b1 b0} 0 0: TRAI0 pin not used 0 1: P1_7 assigned 1 0: P1_5 assigned 1 1: Do not set.	R/W
b1	TRAIOSSEL1			R/W
b2	—	Reserved bits	Set to 0.	R/W
b3	—			
b4	—	Nothing is assigned. If necessary, set to 0. When read, the content is 0.		—
b5	—			
b6	—			
b7	—			

The TRASR register selects which pin is assigned to the timer RA I/O. To use the I/O pin for timer RA, set this register.

Set the TRASR register before setting the timer RA associated registers. Also, do not change the setting value in this register during timer RA operation.

7.4.4 Timer RB/RC Pin Select Register (TRBRCSR)

Address 0181h

Bit	b7	b6	b5	b4	b3	b2	b1	b0
Symbol	—	—	TRCCLKSEL1	—	—	—	TRBOSEL1	TRBOSEL0
After Reset	0	0	0	0	0	0	0	0

Bit	Symbol	Bit Name	Function	R/W
b0	TRBOSEL0	TRBO pin select bit	^{b1 b0} 0 0: P1_3 assigned 0 1: P3_1 assigned 1 0: Do not set. 1 1: TRBO pin not used	R/W
b1	TRBOSEL1			R/W
b2	—	Nothing is assigned. If necessary, set to 0. When read, the content is 0.		—
b3	—			
b4	—	Reserved bit	Set to 0.	R/W
b5	TRCCLKSEL1	TRCCLK pin select bit	0: TRCCLK pin not used 1: P3_3 assigned	R/W
b6	—	Reserved bit	Set to 0.	R/W
b7	—	Nothing is assigned. If necessary, set to 0. When read, the content is 0.		—

The TRBRCSR register selects which pin is assigned to the timer RB and timer RC I/O. To use the I/O pin for timer RB and timer RC, set this register.

Set bits TRBOSEL0 and TRBOSEL1 before setting the timer RB associated registers. Set bit TRCCLKSEL1 before setting the timer RC associated registers. Also, do not change the setting values of bits TRBOSEL0 and TRBOSEL1 during timer RB operation. Do not change the setting values of bit TRCCLKSEL1 during timer RC operation.

7.4.5 Timer RC Pin Select Register 0 (TRCPSR0)

Address 0182h

Bit	b7	b6	b5	b4	b3	b2	b1	b0
Symbol	—	—	—	TRCIOBSEL0	—	—	—	TRCIOASEL0
After Reset	0	0	0	0	0	0	0	0

Bit	Symbol	Bit Name	Function	R/W
b0	TRCIOASEL0	TRCIOA/TRCTRG pin select bit	0: TRCIOA/TRCTRG pin not used 1: P1_1 assigned	R/W
b1	—	Reserved bit	Set to 0.	R/W
b2	—			
b3	—	Nothing is assigned. If necessary, set to 0. When read, the content is 0.		—
b4	TRCIOBSEL0	TRCIOB pin select bit	0: TRCIOB pin not used 1: P1_2 assigned	R/W
b5	—	Reserved bit	Set to 0.	R/W
b6	—			
b7	—	Nothing is assigned. If necessary, set to 0. When read, the content is 0.		—

The TRCPSR0 register selects which pin is assigned to the timer RC I/O. To use the I/O pin for timer RC, set this register.

Set the TRCPSR0 register before setting the timer RC associated registers. Also, do not change the setting value in this register during timer RC operation.

7.4.6 Timer RC Pin Select Register 1 (TRCPSR1)

Address 0183h

Bit	b7	b6	b5	b4	b3	b2	b1	b0
Symbol	—	TRCIODSEL2	TRCIODSEL1	—	—	TRCIOSEL2	TRCIOSEL1	—
After Reset	0	0	0	0	0	0	0	0

Bit	Symbol	Bit Name	Function	R/W
b0	—	Reserved bit	Set to 0.	R/W
b1	TRCIOSEL1	TRCIO pin select bit	^{b2 b1} 0 0: TRCIO pin not used 0 1: P3_4 assigned 1 1: P5_3 assigned Other than above: Do not set.	R/W
b2	TRCIOSEL2			R/W
b3	—	Nothing is assigned. If necessary, set to 0. When read, the content is 0.		—
b4	—	Reserved bit	Set to 0.	R/W
b5	TRCIODSEL1	TRCIOD pin select bit	^{b6 b5} 0 0: TRCIOD pin not used 0 1: P3_5 assigned 1 1: P5_4 assigned Other than above: Do not set.	R/W
b6	TRCIODSEL2			R/W
b7	—	Nothing is assigned. If necessary, set to 0. When read, the content is 0.		—

The TRCPSR1 register selects which pin is assigned to the timer RC I/O. To use the I/O pin for timer RC, set this register.

Set the TRCPSR1 register before setting the timer RC associated registers. Also, do not change the setting value in this register during timer RC operation.

7.4.7 Timer RD Pin Select Register 0 (TRDPSR0)

Address 0184h

Bit	b7	b6	b5	b4	b3	b2	b1	b0
Symbol	—	TRDIOD0SELO	—	TRDIOC0SELO	—	TRDIOB0SELO	—	TRDIOA0SELO
After Reset	0	0	0	0	0	0	0	0

Bit	Symbol	Bit Name	Function	R/W
b0	TRDIOA0SELO	TRDIOA0/TRDCLK pin select bit	0: TRDIOA0/TRDCLK pin not used 1: P3_5 assigned	R/W
b1	—	Nothing is assigned. If necessary, set to 0. When read, the content is 0.		—
b2	TRDIOB0SELO	TRDIOB0 pin select bit	0: TRDIOB0 pin not used 1: P3_4 assigned	R/W
b3	—	Reserved bit	Set to 0.	R/W
b4	TRDIOC0SELO	TRDIOC0 pin select bit	0: TRDIOC0 pin not used 1: P3_7 assigned	R/W
b5	—	Reserved bit	Set to 0.	R/W
b6	TRDIOD0SELO	TRDIOD0 pin select bit	0: TRDIOD0 pin not used 1: P3_3 assigned	R/W
b7	—	Nothing is assigned. If necessary, set to 0. When read, the content is 0.		—

The TRDPSR0 register selects which pin is assigned to the timer RD I/O. To use the I/O pin for timer RD, set this register.

Set the TRDPSR0 register before setting the timer RD associated registers. Also, do not change the setting value in this register during timer RD operation.

7.4.8 Timer RD Pin Select Register 1 (TRDPSR1)

Address 0185h

Bit	b7	b6	b5	b4	b3	b2	b1	b0
Symbol	—	TRDIOD1SELO	—	TRDIOC1SELO	—	TRDIOB1SELO	—	TRDIOA1SELO
After Reset	0	0	0	0	0	0	0	0

Bit	Symbol	Bit Name	Function	R/W
b0	TRDIOA1SELO	TRDIOA1 pin select bit	0: TRDIOA1 pin not used 1: P1_0 assigned	R/W
b1	—	Nothing is assigned. If necessary, set to 0. When read, the content is 0.		—
b2	TRDIOB1SELO	TRDIOB1 pin select bit	0: TRDIOB1 pin not used 1: P1_1 assigned	R/W
b3	—	Nothing is assigned. If necessary, set to 0. When read, the content is 0.		—
b4	TRDIOC1SELO	TRDIOC1 pin select bit	0: TRDIOC1 pin not used 1: P1_2 assigned	R/W
b5	—	Reserved bit	Set to 0.	R/W
b6	TRDIOD1SELO	TRDIOD1 pin select bit	0: TRDIOD1 pin not used 1: P1_3 assigned	R/W
b7	—	Reserved bit	Set to 0.	R/W

The TRDPSR1 register selects which pin is assigned to the timer RD I/O. To use the I/O pin for timer RD, set this register.

Set the TRDPSR1 register before setting the timer RD associated registers. Also, do not change the setting value in this register during timer RD operation.

7.4.9 UART0 Pin Select Register (U0SR)

Address 0188h

Bit	b7	b6	b5	b4	b3	b2	b1	b0
Symbol	—	—	—	CLK0SEL0	—	RXD0SEL0	—	TXD0SEL0
After Reset	0	0	0	0	0	0	0	0

Bit	Symbol	Bit Name	Function	R/W
b0	TXD0SEL0	TXD0 pin select bit	0: TXD0 pin not used 1: P1_4 assigned	R/W
b1	—	Nothing is assigned. If necessary, set to 0. When read, the content is 0.		—
b2	RXD0SEL0	RXD0 pin select bit	0: RXD0 pin not used 1: P1_5 assigned	R/W
b3	—	Nothing is assigned. If necessary, set to 0. When read, the content is 0.		—
b4	CLK0SEL0	CLK0 pin select bit	0: CLK0 pin not used 1: P1_6 assigned	R/W
b5	—	Nothing is assigned. If necessary, set to 0. When read, the content is 0.		—
b6	—			
b7	—			

The U0SR register selects which pin is assigned to the UART0 I/O. To use the I/O pin for UART0, set this register.

Set the U0SR register before setting the UART0 associated registers. Also, do not change the setting value in this register during UART0 operation.

7.4.10 UART2 Pin Select Register 0 (U2SR0)

Address 018Ah

Bit	b7	b6	b5	b4	b3	b2	b1	b0
Symbol	—	RXD2SEL2	RXD2SEL1	RXD2SEL0	—	TXD2SEL2	TXD2SEL1	TXD2SEL0
After Reset	0	0	0	0	0	0	0	0

Bit	Symbol	Bit Name	Function	R/W
b0	TXD2SEL0	TXD2/SDA2 pin select bit	b2 b1 b0 0 0 0: TXD2/SDA2 pin not used 0 0 1: P3_7 assigned 0 1 1: P0_0 assigned 1 1 0: P3_6 assigned Other than above: Do not set.	R/W
b1	TXD2SEL1			R/W
b2	TXD2SEL2			R/W
b3	—	Nothing is assigned. If necessary, set to 0. When read, the content is 0.		—
b4	RXD2SEL0	RXD2/SCL2 pin select bit	b6 b5 b4 0 0 0: RXD2/SCL2 pin not used 0 1 0: P3_7 assigned 0 1 1: P4_5 assigned 1 1 0: P3_6 assigned Other than above: Do not set.	R/W
b5	RXD2SEL1			R/W
b6	RXD2SEL2			R/W
b7	—	Nothing is assigned. If necessary, set to 0. When read, the content is 0.		—

The U2SR0 register selects which pin is assigned to the UART2 I/O. To use the I/O pin for UART2, set this register.

Set the U2SR0 register before setting the UART2 associated registers. Also, do not change the setting value in this register during UART2 operation.

7.4.11 UART2 Pin Select Register 1 (U2SR1)

Address 018Bh

Bit	b7	b6	b5	b4	b3	b2	b1	b0
Symbol	—	—	—	CTS2SEL0	—	—	CLK2SEL1	CLK2SEL0
After Reset	0	0	0	0	0	0	0	0

Bit	Symbol	Bit Name	Function	R/W
b0	CLK2SEL0	CLK2 pin select bit	b1 b0 0 0: CLK2 pin not used 0 1: P3_5 assigned 1 0: P0_5 assigned 1 1: Do not set.	R/W
b1	CLK2SEL1			R/W
b2	—	Nothing is assigned. If necessary, set to 0. When read, the content is 0.		—
b3	—			—
b4	CTS2SEL0	CTS2/RTS2 pin select bit	0: CTS2/RTS2 pin not used 1: P3_3 assigned	R/W
b5	—	Reserved bit	Set to 0.	R/W
b6	—	Nothing is assigned. If necessary, set to 0. When read, the content is 0.		—
b7	—			—

The U2SR1 register selects which pin is assigned to the UART2 I/O. To use the I/O pin for UART2, set this register.

Set the U2SR1 register before setting the UART2 associated registers. Also, do not change the setting value in this register during UART2 operation.

7.4.12 SSU Pin Select Register (SSUICSR)

Address 018Ch

Bit	b7	b6	b5	b4	b3	b2	b1	b0
Symbol	—	SCSSEL0	SSISEL1	SSISEL0	—	—	—	—
After Reset	0	0	0	0	0	0	0	0

Bit	Symbol	Bit Name	Function	R/W
b0	—	Reserved bits	Set to 0.	R/W
b1	—			R/W
b2	—	Nothing is assigned. If necessary, set to 0. When read, the content is 0.		—
b3	—			—
b4	SSISEL0	SSI pin select bit	b5 b4 0 0: SSI pin not used 0 1: P3_3 assigned 1 0: P1_6 assigned 1 1: Do not set.	R/W
b5	SSISEL1			R/W
b6	SCSSEL0	SCS pin select bit	0: SCS pin not used 1: P3_4 assigned	R/W
b7	—	Nothing is assigned. If necessary, set to 0. When read, the content is 0.		R/W

Bits SSISEL0 and SSISEL1 (SSI pin select bit)

Bits SSISEL0 and SSISEL1 select which pin is assigned to the SSU I/O. To use the I/O pin for SSU, set these bit.

Set the SSUICSR register setting the SSU associated registers. Also, do not change the setting value in this register during SSU operation.

SCSSEL0 Bit (SCS pin select bit)

The SCSSEL0 bit selects which pin is assigned to the SSU I/O. To use the I/O pin for SSU, set this bit.

Set the SSUICSR register setting the SSU associated registers. Also, do not change the setting value in this register during SSU operation.

7.4.13 INT Interrupt Input Pin Select Register (INTSR)

Address 018Eh

Bit	b7	b6	b5	b4	b3	b2	b1	b0
Symbol	—	—	—	—	—	INT1SEL1	INT1SELO	—
After Reset	0	0	0	0	0	0	0	0

Bit	Symbol	Bit Name	Function	R/W
b0	—	Nothing is assigned. If necessary, set to 0. When read, the content is 0.		—
b1	INT1SELO	INT1 pin select bit	^{b2 b1} 0 0: P1_7 assigned 0 1: P1_5 assigned 1 1: P3_6 assigned Other than above: Do not set.	R/W
b2	INT1SEL1			R/W
b3	—	Reserved bit	Set to 0.	R/W
b4	—			R/W
b5	—			R/W
b6	—			R/W
b7	—			R/W

The INTSR register selects which pin is assigned to the $\overline{\text{INT1}}$ input. To use $\overline{\text{INT1}}$, set this register. Set the INTSR register before setting the $\overline{\text{INT1}}$ associated registers. Also, do not change the setting values in this register during $\overline{\text{INT1}}$ operation.

7.4.14 I/O Function Pin Select Register (PINSR)

Address 018Fh

Bit	b7	b6	b5	b4	b3	b2	b1	b0
Symbol	—	—	—	—	IOINSEL	—	—	—
After Reset	0	0	0	0	0	0	0	0

Bit	Symbol	Bit Name	Function	R/W
b0	—	Nothing is assigned. If necessary, set to 0. When read, the content is 0.		—
b1	—	Reserved bits	Set to 0.	R/W
b2	—	Nothing is assigned. If necessary, set to 0. When read, the content is 0.		—
b3	IOINSEL	I/O port input function select bit	0: The I/O port input function depends on the PDi (i = 0 to 1, 3 to 5) register. When the PDi_j (j = 0 to 7) bit in the PDi register is set to 0 (input mode), the pin input level is read. When the PDi_j bit in the PDi register is set to 1 (output mode), the port latch is read. 1: The I/O port input function reads the pin input level regardless of the PDi register.	R/W
b4	—	Reserved bits	Set to 0.	R/W
b5	—			
b6	—			
b7	—			

IOINSEL Bit (I/O port input function select bit)

The IOINSEL bit is used to select the pin level of an I/O port when the PDi_j (j = 0 to 7) bit in the PDi (i = 0 to 1, 3 to 5) register is set to 1 (output mode). When this bit is set to 1, the I/O port input function reads the pin input level regardless of the PDi register.

Table 7.4 lists I/O Port Values Read by Using IOINSEL Bit. The IOINSEL bit can be used to change the input function of all I/O ports except P4_2.

Table 7.4 I/O Port Values Read by Using IOINSEL Bit

PDi_j bit in PDi register	0 (input mode)		1 (output mode)		
	IOINSEL bit	0	1	0	1
I/O port values read		Pin input level	Port latch value	Pin input level	

7.4.15 Pull-Up Control Register 0 (PUR0)

Address 01E0h

Bit	b7	b6	b5	b4	b3	b2	b1	b0
Symbol	PU07	PU06	—	—	PU03	PU02	PU01	PU00
After Reset	0	0	0	0	0	0	0	0

Bit	Symbol	Bit Name	Function	R/W
b0	PU00	P0_0 to P0_3 pull-up	0: Not pulled up 1: Pulled up ⁽¹⁾	R/W
b1	PU01	P0_4 to P0_7 pull-up		R/W
b2	PU02	P1_0 to P1_3 pull-up		R/W
b3	PU03	P1_4 to P1_7 pull-up		R/W
b4	—	Reserved bits	Set to 0.	R/W
b5	—			
b6	PU06	P3_1, P3_3 pull-up	0: Not pulled up 1: Pulled up ⁽¹⁾	R/W
b7	PU07	P3_4 to P3_7 pull-up		R/W

Note:

- When this bit is set to 1 (pulled up), the pin whose port direction bit is set to 0 (input mode) is pulled up.

For pins used as input, the setting values in the PUR0 register are valid.

7.4.16 Pull-Up Control Register 1 (PUR1)

Address 01E1h

Bit	b7	b6	b5	b4	b3	b2	b1	b0
Symbol	—	—	—	—	PU13	PU12	PU11	—
After Reset	0	0	0	0	0	0	0	0

Bit	Symbol	Bit Name	Function	R/W
b0	—	Reserved bit	Set to 0.	R/W
b1	PU11	P4_5 to P4_7 pull-up	0: Not pulled up 1: Pulled up ⁽¹⁾	R/W
b2	PU12	P5_3 pull-up		R/W
b3	PU13	P5_4 pull-up		R/W
b4	—	Reserved bits	Set to 0.	R/W
b5	—			
b6	—	Nothing is assigned. If necessary, set to 0. When read, the content is undefined.		—
b7	—			

Note:

- When this bit is set to 1 (pulled up), the pin whose port direction bit is set to 0 (input mode) is pulled up.

For pins used as input, the setting values in the PUR1 register are valid.

7.4.17 Input Threshold Control Register 0 (VLT0)

Address 01F5h

Bit	b7	b6	b5	b4	b3	b2	b1	b0
Symbol	VLT07	VLT06	—	—	VLT03	VLT02	VLT01	VLT00
After Reset	0	0	0	0	0	0	0	0

Bit	Symbol	Bit Name	Function	R/W
b0	VLT00	P0 input level select bit	^{b1 b0} 0 0: 0.50 × VCC 0 1: 0.35 × VCC 1 0: 0.70 × VCC 1 1: Do not set.	R/W
b1	VLT01			R/W
b2	VLT02	P1 input level select bit	^{b3 b2} 0 0: 0.50 × VCC 0 1: 0.35 × VCC 1 0: 0.70 × VCC 1 1: Do not set.	R/W
b3	VLT03			R/W
b4	—	Reserved bits	Set to 0.	R/W
b5	—			R/W
b6	VLT06	P3_1, P3_3 to P3_7 input level select bit	^{b7 b6} 0 0: 0.50 × VCC 0 1: 0.35 × VCC 1 0: 0.70 × VCC 1 1: Do not set.	R/W
b7	VLT07			R/W

The VLT0 register selects the voltage level of the input threshold values for ports P0 to P1, P3_1, P3_3 to P3_7. Bits VLT00 to VLT03 and VLT06 to VLT07 are used to select the input threshold values among three voltage levels (0.35 VCC, 0.50 VCC, and 0.70 VCC).

7.4.18 Input Threshold Control Register 1 (VLT1)

Address 01F6h

Bit	b7	b6	b5	b4	b3	b2	b1	b0
Symbol	—	—	—	—	VLT13	VLT12	VLT11	VLT10
After Reset	0	0	0	0	0	0	0	0

Bit	Symbol	Bit Name	Function	R/W
b0	VLT10	P4_2, P4_5 to P4_7 input level select bit	^{b1 b0} 0 0: 0.50 × VCC 0 1: 0.35 × VCC 1 0: 0.70 × VCC 1 1: Do not set.	R/W
b1	VLT11			R/W
b2	VLT12	P5_3 and P5_4 input level select bit	^{b3 b2} 0 0: 0.50 × VCC 0 1: 0.35 × VCC 1 0: 0.70 × VCC 1 1: Do not set.	R/W
b3	VLT13			R/W
b4	—	Reserved bits	Set to 0.	R/W
b5	—			R/W
b6	—	Nothing is assigned. If necessary, set to 0. When read, the content is 0.		—
b7	—			—

The VLT1 register selects the voltage level of the input threshold values for ports P4_2, P4_5 to P4_7, P5_3, and P5_4. Bits VLT10 to VLT13 are used to select the input threshold values among three voltage levels (0.35 VCC, 0.50 VCC, and 0.70 VCC).

7.5 Port Settings

Tables 7.5 to 7.45 list the port settings.

Table 7.5 Port P0_0/AN7/TXD2/SDA2

Register	PD0	ADINSEL					U2SR0			U2MR			U2SMR	Function	
Bit	PD0_0	CH			ADGSEL		TXD2SEL			SMD			IICM		
		2	1	0	1	0	2	1	0	2	1	0			
Setting Value	0	X	X	X	X	X	Other than 011b			X	X	X	X	Input port ⁽¹⁾	
	1	X	X	X	X	X	Other than 011b			X	X	X	X	Output port	
	0	1	1	1	0	0	Other than 011b			X	X	X	X	A/D converter input (AN7) ⁽¹⁾	
	X	X	X	X	X	X	0	1	1	1	0	0	1	X	TXD2 output ⁽²⁾
											0		0	X	
											1		0	X	
0	X	X	X	X	X	0	1	1	0	1	0	1	SDA2 input/output ⁽²⁾		

X: 0 or 1

Notes:

1. Pulled up by setting the PU00 bit in the PUR0 register to 1.
2. N-channel open-drain output by setting the NCH bit in the U2C0 register to 1.

Table 7.6 Port P0_1/AN6

Register	PD0	ADINSEL					Function
Bit	PD0_1	CH			ADGSEL		
		2	1	0	1	0	
Setting Value	0	X	X	X	X	X	Input port ⁽¹⁾
	1	X	X	X	X	X	Output port
	0	1	1	0	0	0	A/D converter input (AN6) ⁽¹⁾

X: 0 or 1

Note:

1. Pulled up by setting the PU00 bit in the PUR0 register to 1.

Table 7.7 Port P0_2/AN5

Register	PD0	ADINSEL					Function
Bit	PD0_2	CH			ADGSEL		
		2	1	0	1	0	
Setting Value	0	X	X	X	X	X	Input port ⁽¹⁾
	1	X	X	X	X	X	Output port
	0	1	0	1	0	0	A/D converter input (AN5) ⁽¹⁾

X: 0 or 1

Note:

1. Pulled up by setting the PU00 bit in the PUR0 register to 1.

Table 7.8 Port P0_3/AN4

Register	PD0	ADINSEL					Function
Bit	PD0_3	CH			ADGSEL		
		2	1	0	1	0	
Setting Value	0	X	X	X	X	X	Input port ⁽¹⁾
	1	X	X	X	X	X	Output port
	0	1	0	0	0	0	A/D converter input (AN4) ⁽¹⁾

X: 0 or 1

Note:

1. Pulled up by setting the PU00 bit in the PUR0 register to 1.

Table 7.9 Port P0_4/AN3

Register	PD0	ADINSEL					Function
Bit	PD0_4	CH			ADGSEL		
		2	1	0	1	0	
Setting Value	0	X	X	X	X	X	Input port ⁽¹⁾
	1	X	X	X	X	X	Output port
	0	0	1	1	0	0	A/D converter input (AN3) ⁽¹⁾

X: 0 or 1

Note:

1. Pulled up by setting the PU01 bit in the PUR0 register to 1.

Table 7.10 Port P0_5/AN2/CLK2

Register	PD0	ADINSEL					USR1	U2MR				Function	
Bit	PD0_5	CH			ADGSEL		CLK2SEL		SMD				CKDIR
		2	1	0	1	0	1	0	2	1	0		0
Setting Value	0	X	X	X	X	X	Other than 10b		X	X	X	X	Input port ⁽¹⁾
	1	X	X	X	X	X	Other than 10b		X	X	X	X	Output port
	0	0	1	0	0	0	Other than 10b		X	X	X	X	A/D converter input (AN2) ⁽¹⁾
	0	X					1	0	X	X	X	1	CLK2 input (external clock) ⁽¹⁾
	X	X					1	0	0	0	1	0	CLK2 output (internal clock) ⁽²⁾

X: 0 or 1

Notes:

1. Pulled up by setting the PU01 bit in the PUR0 register to 1.
2. N-channel open-drain output by setting the NODC bit in the U2SMR3 register to 1.

Table 7.11 Port P0_6/AN1/DA0

Register	PD0	ADINSEL					DACON	Function
Bit	PD0_6	CH			ADGSEL		DA0E	
		2	1	0	1	0		
Setting Value	0	X	X	X	X	X	0	Input port ⁽¹⁾
	1	X	X	X	X	X	0	Output port
	0	0	0	1	0	0	0	A/D converter input (AN1) ⁽¹⁾
	0	X	X	X	X	X	1	D/A converter output (DA0) ⁽¹⁾

X: 0 or 1

Note:

1. Pulled up by setting the PU01 bit in the PUR0 register to 1.

Table 7.12 Port P0_7/AN0/DA1

Register	PD0	ADINSEL					DACON	Function
Bit	PD0_7	CH			ADGSEL		DA1E	
		2	1	0	1	0		
Setting Value	0	X	X	X	X	X	0	Input port ⁽¹⁾
	1	X	X	X	X	X	0	Output port
	0	0	0	0	0	0	0	A/D converter input (AN0) ⁽¹⁾
	0	X	X	X	X	X	1	D/A converter output (DA1) ⁽¹⁾

X: 0 or 1

Note:

1. Pulled up by setting the PU01 bit in the PUR0 register to 1.

Table 7.13 Port P1_0/KI0/AN8/TRDIOA1

Register	PD1	KIEN	ADINSEL						TRDPSR1	Timer RD Setting	Function
Bit	PD1_0	KI0EN	CH			ADGSEL		TRDIOA1SEL0	—		
			2	1	0	1	0	0			
Setting Value	0	X	X	X	X	X	X	0	X	Input port ⁽¹⁾	
	1	X	X	X	X	X	X	0	X	Output port	
	0	1	X	X	X	X	X	0	X	$\overline{KI0}$ input ⁽¹⁾	
	0	0	0	0	0	0	1	0	X	A/D converter input (AN8) ⁽¹⁾	
	0	X	X	X	X	X	X	1	Refer to Table 7.42 TRDIOA1 Pin Setting	TRDIOA1 input ⁽¹⁾	
	X	X	X	X	X	X	X	1	Refer to Table 7.42 TRDIOA1 Pin Setting	TRDIOA1 output	

X: 0 or 1

Note:

1. Pulled up by setting the PU02 bit in the PUR0 register to 1.

Table 7.14 Port P1_1/KI1/AN9/TRCIOA/TRCTR/GR/TRDIOB1

Register	PD1	KIEN	ADINSEL						TRCPSR0	Timer RC Setting	TRDPSR1	Timer RD Setting	Function
Bit	PD1_1	KI1EN	CH			ADGSEL		TRCIOASEL	—	TRDIOB1SEL0	—		
			2	1	0	1	0	0					
Setting Value	0	X	X	X	X	X	X	0	X	0	X	Input port ⁽¹⁾	
	1	X	X	X	X	X	X	0	X	0	X	Output port	
	0	1	X	X	X	X	X	0	X	0	X	$\overline{KI1}$ input ⁽¹⁾	
	0	0	0	0	1	0	1	0	X	0	X	A/D converter input (AN9) ⁽¹⁾	
	0	X	X	X	X	X	X	1	Refer to Table 7.34 TRCIOA Pin Setting	0	X	TRCIOA input ⁽¹⁾	
	X	X	X	X	X	X	X	1	Refer to Table 7.34 TRCIOA Pin Setting	0	X	TRCIOA output	
	0	X	X	X	X	X	X	0	X	1	Refer to Table 7.43 TRDIOB1 Pin Setting	TRDIOB1 input ⁽¹⁾	
	X	X	X	X	X	X	X	0	X	1	Refer to Table 7.43 TRDIOB1 Pin Setting	TRDIOB1 output	

X: 0 or 1

Note:

1. Pulled up by setting the PU02 bit in the PUR0 register to 1.

Table 7.15 Port P1_2/KI2/AN10/TRCIOB/TRDIOC1

Register	PD1	KIEN	ADINSEL						TRCPSR0	Timer RC Setting	TRDPSR1	Timer RD Setting	Function
Bit	PD1_2	KI2EN	CH			ADGSEL			TRCIOBSEL	—	TRDIOC1SEL0	—	
			2	1	0	1	0	0					
Setting Value	0	X	X	X	X	X	X	0	X	0	X	Input port ⁽¹⁾	
	1	X	X	X	X	X	X	0	X	0	X	Output port	
	0	1	X	X	X	X	X	0	X	0	X	$\overline{\text{KI2}}$ input ⁽¹⁾	
	0	0	0	1	0	0	1	0	X	0	X	A/D converter input (AN10) ⁽¹⁾	
	0	X	X	X	X	X	X	1	Refer to Table 7.35 TRCIOB Pin Setting	0	X	TRCIOB input ⁽¹⁾	
	X	X	X	X	X	X	X	1	Refer to Table 7.35 TRCIOB Pin Setting	0	X	TRCIOB output	
	0	X	X	X	X	X	X	0	X	1	Refer to Table 7.44 TRDIOC1 Pin Setting	TRDIOC1 input ⁽¹⁾	
	X	X	X	X	X	X	X	0	X	1	Refer to Table 7.44 TRDIOC1 Pin Setting	TRDIOC1 output	

X: 0 or 1

Note:

1. Pulled up by setting the PU02 bit in the PUR0 register to 1.

Table 7.16 Port P1_3/KI3/AN11/TRBO/TRDIOD1

Register	PD1	KIEN	ADINSEL					TRBRCSR		Timer RB Setting	TRDPSR1	Timer RD Setting	Function	
Bit	PD1_3	KI3EN	CH			ADGSEL		TRBOSEL0		—	TRDIOD1SEL0	—		
			2	1	0	1	0	1	0					
Setting Value	0	X	X	X	X	X	X	X	1	0	X	0	X	Input port (1, 2)
									0	1				
									0	0				
	1	X	X	X	X	X	X	X	1	X	X	0	X	Output port
									0	1				
									0	0				
	0	1	X	X	X	X	X	X	1	X	X	0	X	$\overline{\text{KI3}}$ input (1)
									0	1				
									0	0				
	0	0	0	1	1	0	1	1	1	X	X	0	X	A/D converter input (AN11) (1)
									0	1				
									0	0				
	X	X	X	X	X	X	X	X	0	0	Refer to Table 7.33 TRBO Pin Setting	0	X	TRBO output
	0	X	X	X	X	X	X	X	1	1	X	1	Refer to Table 7.45 TRDIOD1 Pin Setting	TRDIOD1 input (1)
0									1					
0									0	Other than TRBO usage conditions				
X	X	X	X	X	X	X	X	1	X	X	1	Refer to Table 7.45 TRDIOD1 Pin Setting	TRDIOD1 output	
								0	1					
								0	0					Other than TRBO usage conditions

X: 0 or 1

Notes:

1. Pulled up by setting the PU02 bit in the PUR0 register to 1.
2. Do not set bits TRBOSEL1 to TRBOSEL0 in the TRBRCSR register to 10b.

Table 7.17 Port P1_4/TXD0

Register	PD1	U0SR	U0MR			Function
Bit	PD1_4	TXD0SELO	SMD			
			2	1	0	
Setting Value	0	0	X	X	X	Input port ⁽¹⁾
	1	0	X	X	X	Output port
	X	1	0	0	1	TXD0 output ⁽²⁾
			1		0	
			1	1	0	

X: 0 or 1

Notes:

1. Pulled up by setting the PU03 bit in the PUR0 register to 1.
2. N-channel open-drain output by setting the NCH bit in the UOC0 register to 1.

Table 7.18 Port P1_5/RXD0/TRAI0/ $\overline{\text{INT1}}$

Register	PD1	U0SR	TRASR		TRAI0C	TRAMR			INTSR		INTEN	INTCMP	Function
Bit	PD1_5	RXD0SELO	TRAI0SEL		TOPCR	TMOD			INT1SEL		INT1EN	INT1CP0	
			1	0		2	1	0	1	0			
Setting Value	0	X	Other than 10b		X	X	X	X	X	X	X	X	Input port ⁽¹⁾
	1	X	Other than 10b		X	X	X	X	X	X	X	X	Output port
	0	1	Other than 10b		X	X	X	X	X	X	X	X	RXD0 input ⁽¹⁾
	0	X	1	0	0	Other than 000b, 001b			X	X	X	X	TRAI0 input ⁽¹⁾
	0	X	Other than 10b		X	X	X	X	0	1	1	0	$\overline{\text{INT1}}$ input ⁽¹⁾
	0	X	1	0	0	Other than 000b, 001b			0	1	1	0	TRAI0/ $\overline{\text{INT1}}$ input ⁽¹⁾
	X	X	1	0	0	0	0	1	X	X	X	X	TRAI0 pulse output
	0	1	1	0	0	Master mode: 000b Slave mode: 011b			X	X	X	X	TRAI0/RXD0 input (Hardware LIN)
	0	1	1	0	0				0	1	1	0	0

X: 0 or 1

Note:

1. Pulled up by setting the PU03 bit in the PUR0 register to 1.

Table 7.19 Port P1_6/CLK0/SSI/IVREF1

Register	PD1	U0SR	U0MR			INTCMP	SSUICSR		Synchronous Serial Communication Unit (Refer to Table 23.4 Association between Communication Modes and I/O Pins.)		Function	
			Bit	PD1_6	CLK0SEL0		SMD			INT1CP0		SSISEL1
2	1	0										
Setting Value	0	0	X	X	X	X	X	Other than 10b		X	X	Input port ⁽¹⁾
	1	0	X	X	X	X	X	Other than 10b		X	X	Output port
	0	1	X	X	X	1	X	Other than 10b		X	X	CLK0 (external clock) input ⁽¹⁾
	X	1	0	0	1	0	X	Other than 10b		X	X	CLK0 (internal clock) output
	0	0	X	X	X	X	1	Other than 10b		X	X	Comparator B1 reference voltage input (IVREF1) ⁽¹⁾
	X	0	X	X	X	X	X	1	0	0	1	SSI input ⁽¹⁾
	X	0	X	X	X	X	X	1	0	1	0	SSI output ⁽²⁾

X: 0 or 1

Notes:

1. Pulled up by setting the PU03 bit in the PUR0 register to 1.
2. N-channel open-drain output by setting the SOOS bit in the SSMR2 register to 1 (N-channel open-drain output) and setting the BIDE bit in the SSMR2 register to 0 (standard mode).

Table 7.20 Port P1_7/ $\overline{\text{INT1}}$ /TRAIO/IVCMP1

Register	PD1	TRASR		TRAIOC	TRAMR			INTSR		INTEN	INTCMP	Function
		TRAIOSEL			TMOD			INT1SEL				
Bit	PD1_7	1	0	TOPCR	2	1	0	1	0	INT1EN	INT1CP0	
Setting Value	0	Other than 01b		X	X	X	X	X	X	X	X	Input port ⁽¹⁾
	1	Other than 01b		X	X	X	X	X	X	X	X	Output port
	0	0	1	0	Other than 000b, 001b			X	X	X	X	TRAIO input ⁽¹⁾
	0	Other than 01b		X	X	X	X	0	0	1	0	$\overline{\text{INT1}}$ input ⁽¹⁾
	0	0	1	0	Other than 000b, 001b			0	0	1	X	TRAIO/ $\overline{\text{INT1}}$ input ⁽¹⁾
	X	0	1	0	0	0	1	X	X	X	X	TRAIO pulse output
	0	Other than 01b		X	X	X	X	X	X	X	1	1

X: 0 or 1

Note:

1. Pulled up by setting the PU03 bit in the PUR0 register to 1.

Table 7.21 Port P3_1/TRBO

Register	PD3	TRBRCSR		Timer RB Setting	Function
		TRBOSEL			
Bit	PD3_1	1	0		
Setting Value	0	1	1	X	Input port ^(1, 2)
		0	0		
		0	1		
	1	1	X	X	Output port
		0	0		
		0	1		
X	0	1	Refer to Table 7.33 TRBO Pin Setting		TRBO output

X: 0 or 1

Notes:

1. Pulled up by setting the PU06 bit in the PUR0 register to 1.
2. Do not set bits TRBOSEL1 to TRBOSEL0 in the TRBRCSR register to 10b.

Table 7.22 Port P3_3/INT3/(SSI)/CTS2/RTS2/TRCCLK/IVCMP3/TRDIOD0

Register	PD3	INT EN	TRBRCSR	TRCCR1	U2 SR1	U2MR	U2CO	SSUII CSR	Synchronous Serial Communication Unit (Refer to Table 23.4 Association between Communication Modes and I/O Pins.)				TRDPSR0	Timer RD Setting	INT CMP	Function	
Bit	PD3_3	INT3 EN	TRCCLKSEL	TCK	CTS2 SEL0	SMD	CRS	CRD	SSI SEL 1	SSI SEL 0	SSI output control	SSI input control	TRDIOD OSEL0	—	INT3 CP0		
Setting Value	0	X	X	X X X	0	X X X	X	X	Other than 01b		X	X	0	X	X	Input port (1)	
	1	X	X	X X X	0	X X X	X	X	Other than 01b		X	X	0	X	X	Output port	
	0	1	X	X X X	0	X X X	X	X	Other than 01b		X	X	0	X	0	INT3 input (1)	
	0	X	1	1 0 1	0	X X X	X	X	Other than 01b		X	X	0	X	X	TRCCLK input (1)	
	0	X	X	X X X	1	Other than 000b		0	0	Other than 01b		X	X	0	X	X	CTS2 input (1)
	X	X	X	X X X	1	Other than 000b		1	0	Other than 01b		X	X	0	X	X	RTS2 output
	0	X	0	X X X	0	X X X	X	X	Other than 01b		X	X	0	X	1	Comparator B3 input (IVCMP3) (1)	
	X	X	0	X X X	0	X X X	X	X	0	1	0	1	0	X	X	SSI input (1)	
	X	X	0	X X X	0	X X X	X	X	0	1	1	0	0	X	X	SSI output (2)	
	0	X	0	X X X	0	X X X	X	X	Other than 01b		X	X	1	Refer to Table 7.41 TRDIOD0 Pin Setting		X	TRDIOD0 input (1)
X	X	0	X X X	0	X X X	X	X	Other than 01b		X	X	1	Refer to Table 7.41 TRDIOD0 Pin Setting		X	TRDIOD0 output	

X: 0 or 1

Notes:

1. Pulled up by setting the PU06 bit in the PUR0 register to 1.
2. N-channel open-drain output by setting the CSOS bit in the SSMR2 register to 1 (N-channel open-drain output) and setting the BIDE bit in the SSMR2 register to 0 (standard mode).

Table 7.23 Port P3_4/SCS/(TRCIOC)/IVREF3/TRDIOB0

Register	PD3	SSUIICSR	SSMR2	TRCPSR1	Timer RC Setting	TRDPSR0	Timer RD Setting	INTCMP	Function		
Bit	PD3_4	SCSSEL0	CSS	TRCIOC SEL	—	TRDIOB0SEL0	—	INT3CP0			
			1 0	2 1							
Setting Value	0	0	X X	Other than 01b		X	0	X	X	Input port (1)	
	1	0	X X	Other than 01b		X	0	X	X	Output port	
	0	0	X X	0	1	Refer to Table 7.36 TRCIOC Pin Setting		0	X	X	TRCIOC input (1)
	X	0	X X	0	1	Refer to Table 7.36 TRCIOC Pin Setting		0	X	X	TRCIOC output
	0	0	X X	Other than 01b		X	1	Refer to Table 7.39 TRDIOB0 Pin Setting		X	TRDIOB0 input (1)
	X	0	X X	Other than 01b		X	1	Refer to Table 7.39 TRDIOB0 Pin Setting		X	TRDIOB0 output
	X	1	0	1	Other than 01b		X	0	X	X	SCS input (1)
	X	1	1	0	Other than 01b		X	0	X	X	SCS output (2)
	X	1	1	1	Other than 01b		X	0	X	X	Comparator B3 input (IVCMP3) (1)
	0	0	X X	Other than 01b		X	0	X	1		

X: 0 or 1

Notes:

1. Pulled up by setting the PU07 bit in the PUR0 register to 1.
2. N-channel open-drain output by setting the SOOS bit in the SSMR2 register to 1 (N-channel open-drain output).

Table 7.24 Port P3_5/(SSCK)/(TRCIOD)/(CLK2)/TRDIOA0/TRDCLK

Register	PD3	U2SR1		U2MR		Synchronous Serial Communication Unit (Refer to Table 23.4 Association between Communication Modes and I/O Pins.)		TRCPSR1	Timer RC Setting	TRDPSR0	Timer RD Setting	Function			
		CLK2SEL	SMD	CKDIR	SSCK output control	SSCK input control	TRCIODSEL								
Bit	PD3_5	1	0	2	1	0	0	2	1	TRDIOB0 SEL	—	—			
Setting Value	0	Other than 01b		X	X	X	X	0	0	Other than 01b	X	0	X	Input port (1)	
	1	Other than 01b		X	X	X	X	0	0	Other than 01b	X	0	X	Output port	
	0	Other than 01b		X	X	X	X	0	0	0	1	Refer to Table 7.37 TRCIOD Pin Setting	0	X	TRCIOD input (1)
	X	Other than 01b		X	X	X	X	0	0	0	1	Refer to Table 7.37 TRCIOD Pin Setting	0	X	TRCIOD output
	0	0	1	X	X	X	1	0	0	Other than 01b	X	0	X	CLK2 input (1)	
	X	0	1	0	0	1	0	0	0	Other than 01b	X	0	X	CLK2 output (3)	
	X	Other than 01b		X	X	X	X	0	1	Other than 01b	X	0	X	SSCK input (1)	
	X	Other than 01b		X	X	X	X	1	0	Other than 01b	X	0	X	SSCK output (2)	
	0	Other than 01b		X	X	X	X	0	0	Other than 01b	X	1	Refer to Table 7.38 TRDIOA0 Pin Setting	1	TRDIOA0 input (1)
	X	Other than 01b		X	X	X	X	0	0	Other than 01b	X	1	Refer to Table 7.38 TRDIOA0 Pin Setting	1	TRDIOA0 output

X: 0 or 1

Notes:

1. Pulled up by setting the PU07 bit in the PUR0 register to 1.
2. N-channel open-drain output by setting the SCKOS bit in the SSMR2 register to 1 (N-channel open-drain output).
3. N-channel open-drain output by setting the NODC bit in the U2SMR3 register to 1.

Table 7.25 Port P3_6/(TXD2/SDA2)/(RXD2/SCL2)/(INT1)

Register	PD3	INTSR		INTEN	INTCMP	U2SR0						U2MR			U2SMR	Function					
		INT1SEL	INT1EN			INT1CP0	RXD2SEL			TXD2SEL			SMD				IICM				
Bit	PD3_6	1	0	INT1EN	INT1CP0	2	1	0	2	1	0	2	1	0	2	1	0	IICM			
Setting Value	0	X	X	X	X	Other than 110b			Other than 110b			X	X	X	X	X	X	X	Input port (1)		
	1	X	X	X	X	Other than 110b			Other than 110b			X	X	X	X	X	X	X	Output port		
	0	1	1	1	0	Other than 110b			Other than 110b			X	X	X	X	X	X	X	$\overline{\text{INT1}}$ input (1)		
	0	X	X	X	X	1	1	0	Other than 110b			X	X	X	X	X	X	X	X	RXD2 input (1)	
	0	X	X	X	X	1	1	0	Other than 110b			0	1	0	1	0	1	0	1	SCL2 input/output (2)	
	X	X	X	X	X	X	X	X	X	1	1	0	0	0	1	X	X	X	X	X	TXD2 output (2)
													1	0	0						
													1	0	1						
													1	1	0						
	0	X	X	X	X	X	X	X	X	1	1	0	0	1	0	1	0	1	1	SDA2 input/output (2)	

X: 0 or 1

Notes:

1. Pulled up by setting the PU07 bit in the PUR0 register to 1.
2. N-channel open-drain output by setting the NCH bit in the U2C0 register to 1.

Table 7.26 Port P3_7/TRAO/SSO/(RXD2/SCL2)/(TXD2/SDA2)/TRDIOC0

Register	PD3	Synchronous Serial Communication Unit (Refer to Table 23.4 Association between Communication Modes and I/O Pins.)		U2SR0			U2MR			U2SMR	TRAIOC	TRDPSR0	Timer RD Setting	Function				
Bit	PD3_7	SSO output control	SSO input control	RXD2SEL			TXD2SEL			SMD			IICM	TOENA	TRDIOC0SEL0	—		
				2	1	0	2	1	0	2	1	0						
Setting Value	0	0	0	Other than 010b			Other than 001b			X	X	X	X	0	0	X	Input port (1)	
	1	0	0	Other than 010b			Other than 001b			X	X	X	X	0	0	X	Output port	
	X	0	1	X	X	X	X	X	X	X	X	X	X	X	0	X	SSO input (1)	
	X	1	0	X	X	X	X	X	X	X	X	X	X	X	0	X	SSO output (2)	
	0	0	0	0	1	0	Other than 001b			X	X	X	X	0	0	X	RXD2 input (1)	
	0	0	0	0	1	0	Other than 001b			0	1	0	1	X	0	X	SCL2 input (3)	
	X	0	0	X	X	X	0	0	1	0	1	X	X	0	X	X	X	TXD2 output (3)
										0	0							
										1	0							
										1	0							
	0	0	0	X	X	X	0	0	1	0	1	0	1	X	0	X	SDA2 input/output (3)	
X	0	0	Other than 010b			Other than 001b			X	X	X	X	1	0	X	TRAO output		
0	0	0	Other than 010b			Other than 001b			X	X	X	X	0	1	Refer to Table 7.40 TRDIOC0 Pin Setting	TRDIOC0 input (1)		
X	0	0	Other than 010b			Other than 001b			X	X	X	X	0	1	Refer to Table 7.40 TRDIOC0 Pin Setting	TRDIOC0 output		

X: 0 or 1

Notes:

1. Pulled up by setting the PU07 bit in the PUR0 register to 1.
2. N-channel open-drain output by setting the SOOS bit in the SSMR2 register to 1 (N-channel open-drain output).
3. N-channel open-drain output by setting the NCH bit in the U2C0 register to 1.

Table 7.27 Port P4_2/VREF

Register	ADCON1	DACON		Function
Bit	ADSTBY	DA0E	DA1E	
Setting Value	0	0	0	Input port
	Other than 000b			Input port/VREF input

Table 7.28 Port P4_5/INT0/RXD2/SCL2/ADTRG

Register	PD4	INTEN	U2SR0			U2MR			U2SMR	ADMOD		Function
Bit	PD4_5	INT0EN	RXD2SEL			SMD			IICM	ADCAP		
			2	1	0	2	1	0		1	0	
Setting Value	0	X	Other than 011b			X	X	X	X	X	X	Input port (1)
	1	X	Other than 011b			X	X	X	X	X	X	Output port
	0	1	Other than 011b			X	X	X	X	X	X	INT0 input (1)
	0	X	0	1	1	X	X	X	X	X	X	RXD2 input (1)
	0	X	0	1	1	0	1	0	1	X	X	SCL2 input/output (2)
	0	1	Other than 011b			X	X	X	X	1	1	ADTRG input (1)

X: 0 or 1

Notes:

1. Pulled up by setting the PU11 bit in the PUR1 register to 1.
2. N-channel open-drain output by setting the NCH bit in the U2C0 register to 1.

Table 7.29 Port P4_6/XIN

Register	PD4	CM0	CM1			Circuit specifications		Function	
Bit	PD4_6	CM05	CM10	CM11	CM13	Oscillation buffer	Feedback resistor		
Setting Value	0	X	0	X	0	OFF	OFF	Input port ⁽¹⁾	
	1	X	0	X	0	OFF	OFF	Output port	
	X	0	0	0	1	1	ON	ON	XIN-XOUT oscillation (on-chip feedback resistor enabled)
				1			ON	OFF	XIN-XOUT oscillation (on-chip feedback resistor disabled)
		1		0			OFF	ON	XIN-XOUT oscillation stop (on-chip feedback resistor enabled)
				1			OFF	OFF	XIN-XOUT oscillation stop (on-chip feedback resistor disabled)
	X	X	1	X	X	OFF	OFF	Oscillation stop (STOP mode)	

X: 0 or 1

Note:

1. Pulled up by setting the PU11 bit in the PUR1 register to 1.

Table 7.30 Port P4_7/XOUT

Register	PD4	CM0	CM1			Circuit specifications		Function	
Bit	PD4_7	CM05	CM10	CM11	CM13	Oscillation buffer	Feedback resistor		
Setting Value	0	X	0	X	0	OFF	OFF	Input port ⁽¹⁾	
	1	X	0	X	0	OFF	OFF	Output port	
	X	0	0	0	1	1	ON	ON	XIN-XOUT oscillation (on-chip feedback resistor enabled)
				1			ON	OFF	XIN-XOUT oscillation (on-chip feedback resistor disabled)
		1		0			OFF	ON	XIN-XOUT oscillation stop (on-chip feedback resistor enabled)
				1			OFF	OFF	XIN-XOUT oscillation stop (on-chip feedback resistor disabled)
	X	X	1	X	X	OFF	OFF	Oscillation stop (STOP mode)	

X: 0 or 1

Note:

1. Pulled up by setting the PU11 bit in the PUR1 register to 1.

Table 7.31 Port P5_3/TRCIOC

Register	PD5	TRCPSR0		Timer RC Setting	Function
Bit	PD5_3	TRCIOCSEL		—	
		2	1		
Setting Value	0	Other than 11b		X	Input port ⁽¹⁾
	1	Other than 11b		X	Output port
	0	1	1	Refer to Table 7.36 TRCIOC Pin Setting	TRCIOC input ⁽¹⁾
	X	1	1	Refer to Table 7.36 TRCIOC Pin Setting	TRCIOC output

X: 0 or 1

Note:

1. Pulled up by setting the PU12 bit in the PUR1 register to 1.

Table 7.32 Port P5_4/TRCIOD

Register	PD5	TRCPSR0		Timer RC Setting	Function
Bit	PD5_4	TRCIODSEL		—	
		2	1		
Setting Value	0	Other than 11b		X	Input port ⁽¹⁾
	1	Other than 11b		X	Output port
	0	1	1	Refer to Table 7.37 TRCIOD Pin Setting	TRCIOD input ⁽¹⁾
	X	1	1	Refer to Table 7.37 TRCIOD Pin Setting	TRCIOD output

X: 0 or 1

Note:

1. Pulled up by setting the PU13 bit in the PUR1 register to 1.

Table 7.33 TRBO Pin Setting

Register	TRBIOC	TRBMR		Function
Bit	TOCNT	TMOD1	TMOD0	
Setting Value	0	0	1	Programmable waveform generation mode (pulse output)
	1	0	1	Programmable waveform generation mode (programmable output)
	0	1	0	Programmable one-shot generation mode
	0	1	1	Programmable wait one-shot generation mode

Table 7.34 TRCIOA Pin Setting

Register	TRCOER	TRCMR	TRCIOR0			TRCCR2		Function
Bit	EA	PWM2	IOA2	IOA1	IOA0	TCEG1	TCEG0	
Setting Value	0	1	0	0	1	X	X	Timer waveform output (output compare function)
				1	X			
	1	1	1	X	X	X	X	Timer mode (input capture function)
				0	1			PWM2 mode TRCTRIG input
1	0	X	X	X	0	1		
						1	X	

X: 0 or 1

Table 7.35 TRCIOB Pin Setting

Register	TRCOER	TRCMR		TRCIOR0			Function
Bit	EB	PWM2	PWMB	IOB2	IOB1	IOB0	
Setting Value	0	0	X	X	X	X	PWM2 mode waveform output
	0	1	1	X	X	X	PWM mode waveform output
	0	1	0	0	0	1	Timer waveform output (output compare function)
					1	X	
	1	1	0	1	X	X	Timer mode (input capture function)

X: 0 or 1

Table 7.36 TRCIOC Pin Setting

Register	TRCOER	TRCMR		TRCIOR1			Function
Bit	EC	PWM2	PWMC	IOC2	IOC1	IOC0	
Setting Value	0	1	1	X	X	X	PWM mode waveform output
	0	1	0	0	0	1	Timer waveform output (output compare function)
					1	X	
	0	1	0	1	X	X	Timer mode (input capture function)
1							

X: 0 or 1

Table 7.37 TRCIOD Pin Setting

Register	TRCOER	TRCMR		TRCIOR1			Function
Bit	ED	PWM2	PWMD	IOD2	IOD1	IOD0	
Setting Value	0	1	1	X	X	X	PWM mode waveform output
	0	1	0	0	0	1	Timer waveform output (output compare function)
					1	X	
	0	1	0	1	X	X	Timer mode (input capture function)
1							

X: 0 or 1

Table 7.38 TRDIOA0 Pin Setting

Register	TRDOER1	TRDFCR				TRDIORA0			Function
Bit	EA0	CMD1	CMD0	STCLK	PWM3	IOA2	IOA1	IOA0	
Setting Value	X	0	0	0	1	1	X	X	Timer mode (input capture function)
	X	X	X	1	1	0	0	0	External clock input (TRDCLK)
	0	0	0	0	0	X	X	X	PWM3 mode waveform output
	0	0	0	0	1	0	0	1	Timer mode waveform output (output compare function)
1							X		

X: 0 or 1

Table 7.39 TRDIOB0 Pin Setting

Register	TRDOER1	TRDFCR			TRDPMR	TRDIORA0			Function
Bit	EB0	CMD1	CMD0	PWM3	PWMB0	IOB2	IOB1	IOB0	
Setting Value	X	0	0	1	0	1	X	X	Timer mode (input capture function)
	0	1	0	X	X	X	X	X	Complementary PWM mode waveform output
			1						
	0	0	1	X	X	X	X	X	Reset synchronous PWM mode waveform output
	0	0	0	0	X	X	X	X	PWM3 mode waveform output
	0	0	0	1	1	X	X	X	PWM mode waveform output
0	0	0	1	0	0	0	1	X	Timer mode waveform output (output compare function)
						1	X		

X: 0 or 1

Table 7.40 TRDIOC0 Pin Setting

Register	TRDOER1	TRDFCR			TRDPMR	TRDIORC0			Function
Bit	EC0	CMD1	CMD0	PWM3	PWMC0	IOC2	IOC1	IOC0	
Setting Value	X	0	0	1	0	1	X	X	Timer mode (input capture function)
	0	1	0	X	X	X	X	X	Complementary PWM mode waveform output
			1						
	0	0	1	X	X	X	X	X	Reset synchronous PWM mode waveform output
	0	0	0	1	1	X	X	X	PWM mode waveform output
	0	0	0	1	0	0	0	1	X
1							X		

X: 0 or 1

Table 7.41 TRDIOD0 Pin Setting

Register	TRDOER1	TRDFCR			TRDPMR	TRDIORC0			Function
Bit	ED0	CMD1	CMD0	PWM3	PWMD0	IOD2	IOD1	IOD0	
Setting Value	X	0	0	1	0	1	X	X	Timer mode (input capture function)
	0	1	0	X	X	X	X	X	Complementary PWM mode waveform output
			1						
	0	0	1	X	X	X	X	X	Reset synchronous PWM mode waveform output
	0	0	0	1	1	X	X	X	PWM mode waveform output
	0	0	0	1	0	0	0	1	X
1							X		

X: 0 or 1

Table 7.42 TRDIOA1 Pin Setting

Register	TRDOER1	TRDFCR			TRDIOA1			Function
Bit	EA1	CMD1	CMD0	PWM3	IOA2	IOA1	IOA0	
Setting Value	X	0	0	1	1	X	X	Timer mode (input capture function)
	0	1	0	X	X	X	X	Complementary PWM mode waveform output
			1					
	0	0	1	X	X	X	X	Reset synchronous PWM mode waveform output
	0	0	0	1	0	0	1	X
1						X		

X: 0 or 1

Table 7.43 TRDIOB1 Pin Setting

Register	TRDOER1	TRDFCR			TRDPMR	TRDIORA1			Function
Bit	EB1	CMD1	CMD0	PWM3	PWMB1	IOB2	IOB1	IOB0	
Setting Value	X	0	0	1	0	1	X	X	Timer mode (input capture function)
	0	1	0	X	X	X	X	X	Complementary PWM mode waveform output
			1						
	0	0	1	X	X	X	X	X	Reset synchronous PWM mode waveform output
	0	0	0	1	1	X	X	X	PWM mode waveform output
0	0	0	1	0	0	0	1	X	Timer mode waveform output (output compare function)
						1	X		

X: 0 or 1

Table 7.44 TRDIOC1 Pin Setting

Register	TRDOER1	TRDFCR			TRDPMR	TRDIORC1			Function
Bit	EC1	CMD1	CMD0	PWM3	PWMC1	IOC2	IOC1	IOC0	
Setting Value	X	0	0	1	0	1	X	X	Timer mode (input capture function)
	0	1	0	X	X	X	X	X	Complementary PWM mode waveform output
			1						
	0	0	1	X	X	X	X	X	Reset synchronous PWM mode waveform output
	0	0	0	1	1	X	X	X	PWM mode waveform output
0	0	0	1	0	0	0	1	X	Timer mode waveform output (output compare function)
						1	X		

X: 0 or 1

Table 7.45 TRDIOD1 Pin Setting

Register	TRDOER1	TRDFCR			TRDPMR	TRDIORC1			Function
Bit	ED1	CMD1	CMD0	PWM3	PWMD1	IOD2	IOD1	IOD0	
Setting Value	X	0	0	1	0	1	X	X	Timer mode (input capture function)
	0	1	0	X	X	X	X	X	Complementary PWM mode waveform output
			1						
	0	0	1	X	X	X	X	X	Reset synchronous PWM mode waveform output
	0	0	0	1	1	X	X	X	PWM mode waveform output
0	0	0	1	0	0	0	1	X	Timer mode waveform output (output compare function)
						1	X		

X: 0 or 1

7.6 Unassigned Pin Handling

Table 7.46 lists Unassigned Pin Handling.

Table 7.46 Unassigned Pin Handling

Pin Name	Connection
Ports P0 to P1, P3_1, P3_3 to P3_7, P4_5 to P4_7, P5_3, P5_4	<ul style="list-style-type: none"> • After setting to input mode, connect each pin to VSS via a resistor (pull-down) or connect each pin to VCC via a resistor (pull-up). (2) • After setting to output mode, leave these pins open. (1, 2)
Port P4_2/VREF	Connect to VCC
RESET (3)	Connect to VCC via a pull-up resistor (2)

Notes:

1. If these ports are set to output mode and left open, they remain in input mode until they are switched to output mode by a program. The voltage level of these pins may be undefined and the power current may increase while the ports remain in input mode. The content of the direction registers may change due to noise or program runaway caused by noise. In order to enhance program reliability, the program should periodically repeat the setting of the direction registers.
2. Connect these unassigned pins to the MCU using the shortest wire length (2 cm or less) possible.
3. When the power-on reset function is in use.

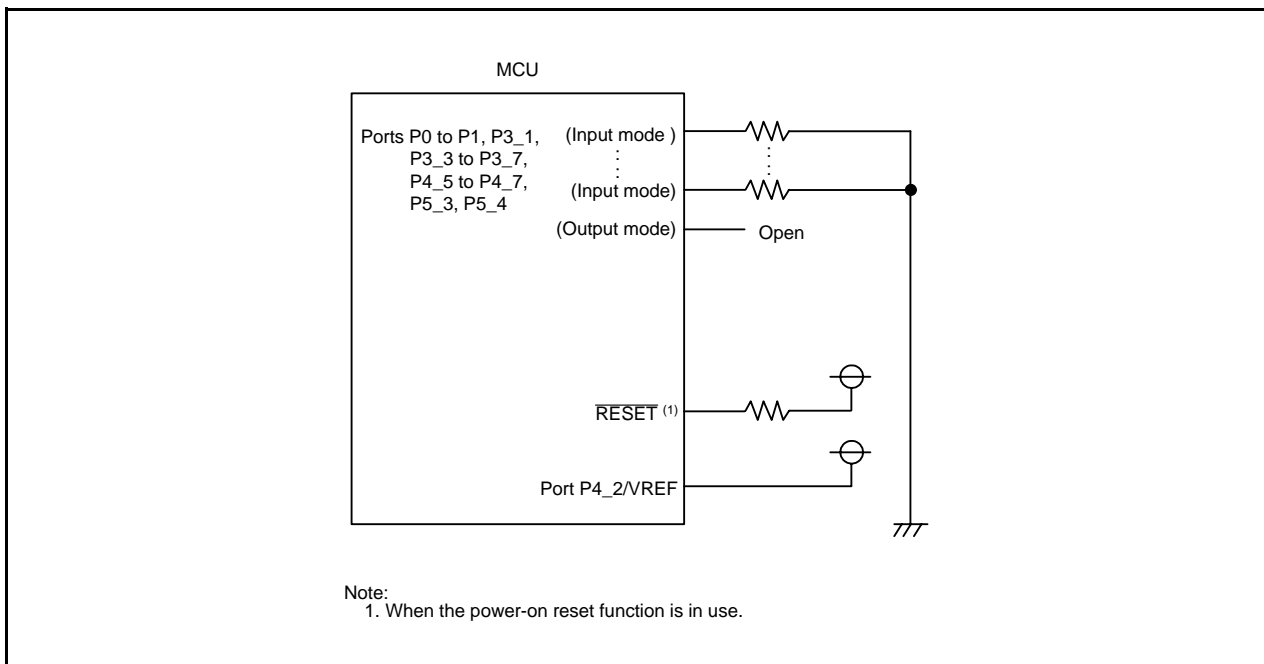

Figure 7.14 Unassigned Pin Handling

8. Bus

The bus cycles differ when accessing ROM, RAM, DTC vector area, DTC control data and when accessing SFR.

Table 8.1 lists Bus Cycles by Access Area of R8C/33G Group, R8C/33H Group.













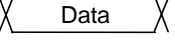



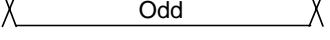
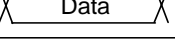

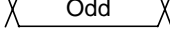

ROM, RAM, DTC vector area, DTC control data and SFR are connected to the CPU by an 8-bit bus. When accessing in word (16-bit) units, these areas are accessed twice in 8-bit units.

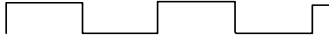
Table 8.2 shows Access Units and Bus Operations.

Table 8.1 Bus Cycles by Access Area of R8C/33G Group, R8C/33H Group

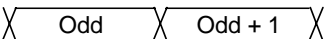
Access Area	Bus Cycle
SFR/Data flash	2 cycles of CPU clock
Program ROM/RAM	1 cycle of CPU clock

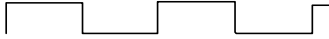
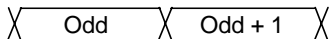
Table 8.2 Access Units and Bus Operations

Area	SFR, Data flash	ROM (program ROM), RAM, DTC vector area, DTC control data
Even address Byte access	CPU clock  Address  Data 	CPU clock  Address  Data 
Odd address Byte access	CPU clock  Address  Data 	CPU clock  Address  Data 
Even address Word access	CPU clock  Address  Data 	CPU clock  Address  Data 
Odd address Word access	CPU clock  Address  Data 	CPU clock  Address  Data 

To use the data flash with more than 16 MHz CPU clock, set the FMR23 bit in the FMR2 register (data flash access cycle selection bit) to 1 (4 cycles of the CPU clock). Table 8.3 shows the Access Unit and Bus Operations for accessing the data flash area.

Table 8.3 Access Units and Bus Operations for Accessing Data Flash Area (FMR32 = 1)

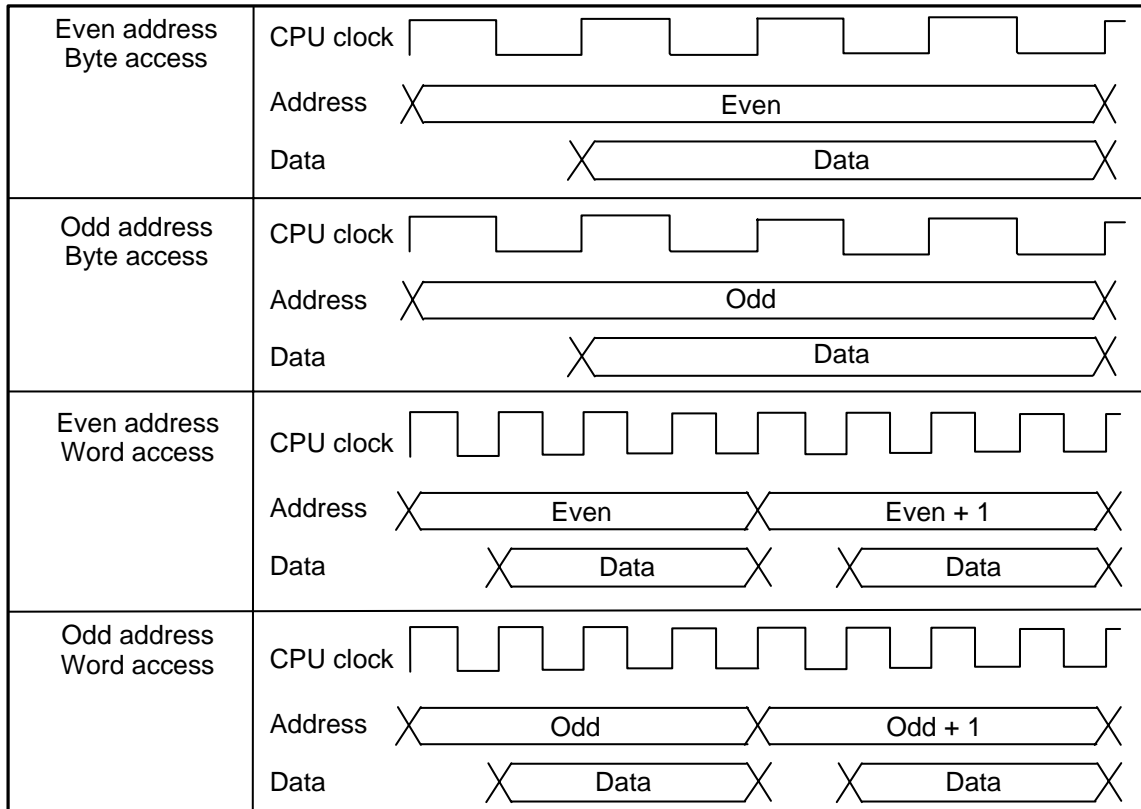

However, only the following SFRs are connected with the 16-bit bus:

Interrupts: Each interrupt control register

Timer RC: Registers TRC, TRCGRA, TRCGRB, TRCGRC, and TRCGRD

Timer RD: Registers TRDi (i = 0, 1), TRDGRAi, TRDGRBi, TRDGRCi, and TRDGRDi

SSU: Registers SSTDR, SSTDRH, SSRDR, and SSRDRH

UART2: Registers U2MR, U2BRG, U2TB, U2C0, U2C1, U2RB, U2SMR5, U2SMR4, U2SMR3, U2SMR2, and U2SMR

A/D converter: Registers AD0, AD1, AD2, AD3, AD4, AD5, AD6, AD7, ADMOD, ADINSEL, ADCON0, and ADCON1

D/A converter: Registers DA0 and DA1

Address match interrupt: Registers RMAD0, AIER0, RMAD1, and AIER1

Therefore, they are accessed once in 16-bit units. The bus operation is the same as “Area: SFR, Data flash, Even address Byte Access” in Table 8.2 Access Units and Bus Operations, and 16-bit data is accessed at a time.

9. Clock Generation Circuit

The following four circuits are incorporated in the clock generation circuit:

- XIN clock oscillation circuit
- Low-speed on-chip oscillator
- High-speed on-chip oscillator
- Low-speed on-chip oscillator for watchdog timer

9.1 Overview

Table 9.1 lists the Specification Overview of Clock Generation Circuit. Figure 9.1 shows a Clock Generation Circuit, Figure 9.2 shows a Peripheral Function Clock.

Table 9.1 Specification Overview of Clock Generation Circuit

Item	XIN Clock Oscillation Circuit	On-Chip Oscillator		Low-Speed On-Chip Oscillator for Watchdog Timer
		High-Speed On-Chip Oscillator	Low-Speed On-Chip Oscillator	
Applications	<ul style="list-style-type: none"> • CPU clock source • Peripheral function clock source 	<ul style="list-style-type: none"> • CPU clock source • Peripheral function clock source • CPU and peripheral function clock source when XIN clock stops oscillating 	<ul style="list-style-type: none"> • CPU clock source • Peripheral function clock source • CPU and peripheral function clock source when XIN clock stops oscillating 	<ul style="list-style-type: none"> • Watchdog timer clock source
Clock frequency	0 to 20 MHz	Approx. 40 MHz ⁽³⁾	Approx. 125 kHz	Approx. 125 kHz
Connectable oscillator	<ul style="list-style-type: none"> • Ceramic resonator • Crystal oscillator 	–	–	–
Oscillator connect pins	XIN, XOUT ⁽¹⁾	– ⁽¹⁾	– ⁽¹⁾	–
Oscillation stop, restart function	Usable	Usable	Usable	Usable
Oscillator status after reset	Stop	Stop	Oscillate	Stop ⁽⁴⁾ Oscillate ⁽⁵⁾
Others	Externally generated clock can be input ⁽²⁾	–	–	–

Notes:

1. These pins can be used as P4_6 and P4_7 when using the on-chip oscillator clock as the CPU clock while the XIN clock oscillation circuit is not used.
2. To input an external clock, set the CM05 bit in the CM0 register to 1 (XIN clock stops), the CM11 bit in the CM1 register to 1 (internal feedback resistor disabled), and the CM13 bit to 1 (XIN-XOUT pin).
3. The clock frequency is automatically set to up to approx.20 MHz by a divider when using the high-speed on-chip oscillator as the CPU clock source.
4. This applies when the CSPROINI bit in the OFS register is set to 1 (count source protection mode disabled after reset).
5. This applies when the CSPROINI bit in the OFS register is set to 0 (count source protection mode enabled after reset).

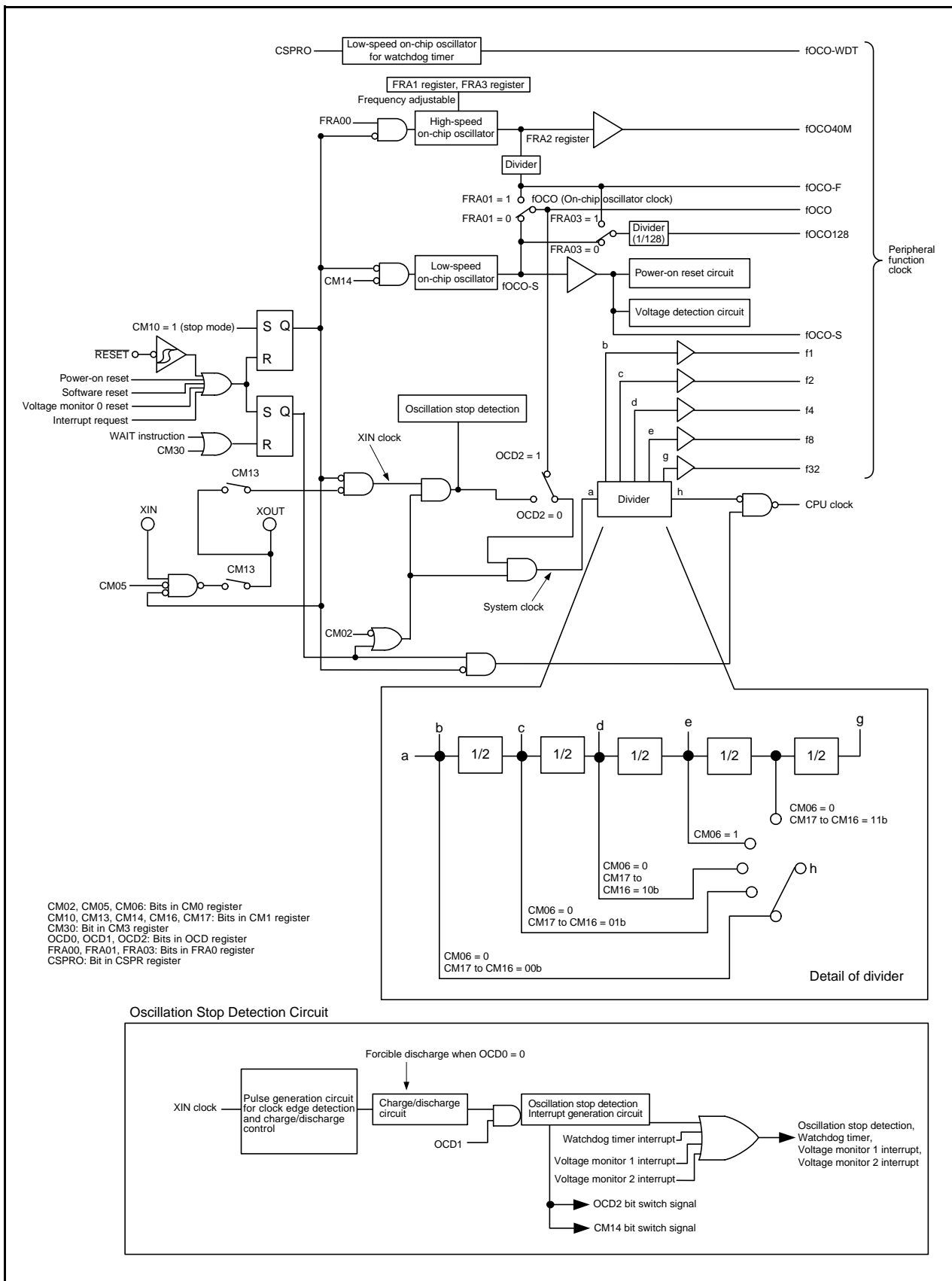

Figure 9.1 Clock Generation Circuit

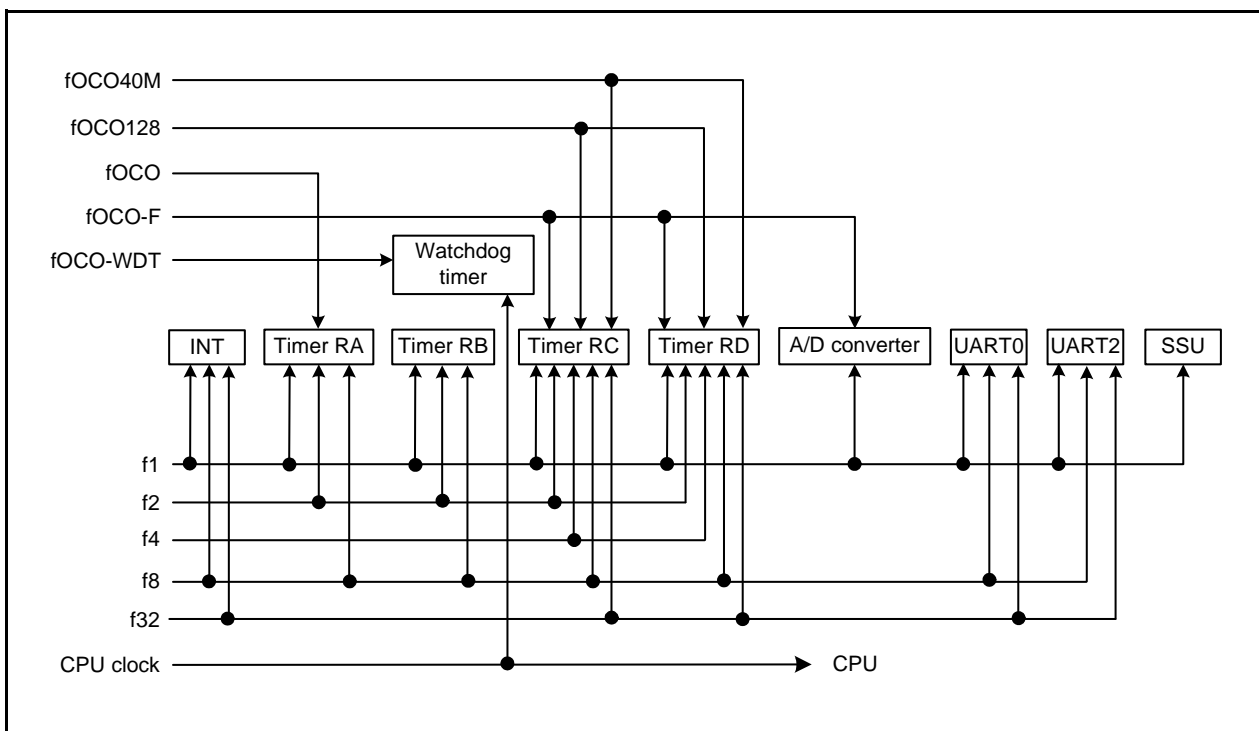

Figure 9.2 Peripheral Function Clock

9.2 Registers

9.2.1 System Clock Control Register 0 (CM0)

Address 0006h

Bit	b7	b6	b5	b4	b3	b2	b1	b0
Symbol	—	CM06	CM05	—	—	CM02	—	—
After Reset	0	0	1	0	1	0	0	0

Bit	Symbol	Bit Name	Function	R/W
b0	—	Reserved bits	Set to 0.	R/W
b1	—			
b2	CM02	Wait mode peripheral function clock stop bit	0: Peripheral function clock does not stop in wait mode 1: Peripheral function clock stops in wait mode	R/W
b3	—	Reserved bit	Set to 1.	R/W
b4	—	Reserved bit	Set to 0.	R/W
b5	CM05	XIN clock (XIN-XOUT) stop bit (1, 3)	0: XIN clock oscillates 1: XIN clock stops (2)	R/W
b6	CM06	CPU clock division select bit 0 (4)	0: Bits CM16 and CM17 in CM1 register enabled 1: Divide-by-8 mode	R/W
b7	—	Reserved bit	Set to 0.	R/W

Notes:

- The CM05 bit stops the XIN clock when the high-speed on-chip oscillator mode or low-speed on-chip oscillator mode is selected. This bit cannot be used to detect whether the XIN clock has stopped. To stop the XIN clock, set the bits in the following order:
 - Set bits OCD1 to OCD0 in the OCD register to 00b.
 - Set the OCD2 bit to 1 (on-chip oscillator clock selected).
- During external clock input, only the clock oscillation buffer stops and clock input is acknowledged.
- Only when the CM05 bit is set to 1 (XIN clock stops) and the CM13 bit in the CM1 register is set to 0 (P4_6 and P4_7), P4_6 and P4_7 can be used as I/O ports.
- When the MCU enters stop mode, the CM06 bit is set to 1 (divide-by-8 mode).

Set the PRC0 bit in the PRCR register to 1 (write enabled) before rewriting the CM0 register.

9.2.2 System Clock Control Register 1 (CM1)

Address 0007h

Bit	b7	b6	b5	b4	b3	b2	b1	b0
Symbol	CM17	CM16	—	CM14	CM13	—	CM11	CM10
After Reset	0	0	1	0	0	0	0	0

Bit	Symbol	Bit Name	Function	R/W
b0	CM10	All clock stop control bit ^(2, 6)	0: Clock oscillates 1: All clocks stop (stop mode)	R/W
b1	CM11	XIN-XOUT on-chip feedback resistor select bit	0: On-chip feedback resistor enabled 1: On-chip feedback resistor disabled	R/W
b2	—	Reserved bit	Set to 0.	R/W
b3	CM13	Port/XIN-XOUT switch bit ⁽⁵⁾	0: I/O ports P4_6 and P4_7 1: XIN-XOUT pin	R/W
b4	CM14	Low-speed on-chip oscillator stop bit ^(3, 4)	0: Low-speed on-chip oscillator on 1: Low-speed on-chip oscillator off	R/W
b5	—	Reserved bit	Set to 1.	R/W
b6	CM16	CPU clock division select bit 1 ⁽¹⁾	^{b7 b6} 0 0: No division mode 0 1: Divide-by-2 mode 1 0: Divide-by-4 mode 1 1: Divide-by-16 mode	R/W
b7	CM17			R/W

Notes:

- When the CM06 bit is set to 0 (bits CM16 and CM17 enabled), bits CM16 and CM17 are enabled.
- If the CM10 bit is set to 1 (stop mode), the on-chip feedback resistor is disabled.
- When the OCD2 bit is set to 0 (XIN clock selected), the CM14 bit can be set to 1 (low-speed on-chip oscillator off). When the OCD2 bit is set to 1 (on-chip oscillator clock selected), the CM14 bit is set to 0 (low-speed on-chip oscillator on). It remains unchanged even if 1 is written to it.
- To use the voltage monitor 1 interrupt or voltage monitor 2 interrupt (when the digital filter is used), set the CM14 bit to 0 (low-speed on-chip oscillator on).
- Once the CM13 bit is set to 1 by a program, it cannot be set to 0.
- Do not set the CM10 bit to 1 (stop mode) when the VCA20 bit in the VCA2 register to 1 (low consumption enabled).

Set the PRC0 bit in the PRCR register to 1 (write enabled) before rewriting the CM1 register.

9.2.3 System Clock Control Register 3 (CM3)

Address 0009h

Bit	b7	b6	b5	b4	b3	b2	b1	b0
Symbol	CM37	CM36	CM35	—	—	—	—	CM30
After Reset	0	0	0	0	0	0	0	0

Bit	Symbol	Bit Name	Function	R/W
b0	CM30	Wait control bit ⁽¹⁾	0: Other than wait mode 1: MCU enters wait mode	R/W
b1	—	Nothing is assigned. If necessary, set to 0. When read, the content is 0.		—
b2	—			
b3	—	Reserved bits	Set to 0.	R/W
b4	—			
b5	CM35	CPU clock division when exiting wait mode select bit ⁽²⁾	0: Following settings are enabled: CM06 bit in CM0 register Bits CM16 and CM17 in CM1 register 1: No division	R/W
b6	CM36	System clock when exiting wait mode or stop mode select bit	^{b7 b6} 0 0: MCU exits with the CPU clock immediately before entering wait or stop mode. 0 1: Do not set. 1 0: High-speed on-chip oscillator clock selected ⁽³⁾ 1 1: XIN clock selected ⁽⁴⁾	R/W
b7	CM37			R/W

Notes:

- When the MCU exits wait mode by a peripheral function interrupt, the CM30 bit is set to 0 (other than wait mode).
- Set the CM35 bit to 0 in stop mode. When the MCU enters wait mode, if the CM35 bit is set to 1 (no division), the CM06 bit in the CM0 register is set to 0 (bits CM16 and CM17 enabled) and bits CM17 and CM16 in the CM1 register is set to 00b (no division mode).
- When bits CM37 and CM36 are set to 10b (high-speed on-chip oscillator clock selected), the following will be set when the MCU exits wait mode or stop mode.
 - OCD2 bit in OCD register = 1 (on-chip oscillator selected)
 - FRA00 bit in FRA0 register = 1 (high-speed on-chip oscillator on)
 - FRA01 bit in FRA0 register = 1 (high-speed on-chip oscillator selected)
- When bits CM37 and CM36 are set to 11b (XIN clock selected), the following will be set when the MCU exits wait mode or stop mode.
 - OM05 bit in OM0 register = 0 (XIN clock oscillates)
 - OM13 bit in OM1 register = 1 (XIN-XOUT pin)
 - OCD2 bit in OCD register = 0 (XIN clock selected)

When the MCU enters wait mode while the CM05 bit in the CM0 register is 1 (XIN clock stops), if the XIN clock is selected as the CPU clock when exiting wait mode, set the CM06 bit to 1 (divide-by-8 mode) and the CM35 bit to 0.

However, if an externally generated clock is used as the XIN clock, do not set bits CM37 to CM36 to 11b (XIN clock selected).

Set the PRC0 bit in the PRCR register to 1 (write enabled) before rewriting the CM3 register.

CM30 bit (Wait Control Bit)

When the CM30 bit is set to 1 (MCU enters wait mode), the CPU clock stops (wait mode). Since the XIN clock and the on-chip oscillator clock do not stop, the peripheral functions using these clocks continue operating. To set the CM30 bit to 1, set the I flag to 0 (maskable interrupt disabled).

The MCU exits wait mode by a reset or peripheral function interrupt. When the MCU exits wait mode by a peripheral function interrupt, it resumes executing the instruction immediately after the instruction to set the CM30 bit to 1.

When the MCU enters wait mode with the WAIT instruction, make sure to set the I flag to 1 (maskable interrupt enabled). With this setting, interrupt handling is performed by the CPU when the MCU exits wait mode.

9.2.4 Oscillation Stop Detection Register (OCD)

Address 000Ch

Bit	b7	b6	b5	b4	b3	b2	b1	b0
Symbol	—	—	—	—	OCD3	OCD2	OCD1	OCD0
After Reset	0	0	0	0	0	1	0	0

Bit	Symbol	Bit Name	Function	R/W
b0	OCD0	Oscillation stop detection enable bit ⁽⁶⁾	0: Oscillation stop detection function disabled ⁽¹⁾ 1: Oscillation stop detection function enabled	R/W
b1	OCD1	Oscillation stop detection interrupt enable bit	0: Disabled ⁽¹⁾ 1: Enabled	R/W
b2	OCD2	System clock select bit ⁽³⁾	0: XIN clock selected ⁽⁶⁾ 1: On-chip oscillator clock selected ⁽²⁾	R/W
b3	OCD3	Clock monitor bit ^(4, 5)	0: XIN clock oscillates 1: XIN clock stops	R
b4	—	Reserved bits	Set to 0.	R/W
b5	—			
b6	—			
b7	—			

Notes:

1. Set bits OCD1 to OCD0 to 00b before the MCU enters stop mode, high-speed on-chip oscillator mode, or low-speed on-chip oscillator mode (XIN clock stops).
2. If the OCD2 bit is set to 1 (on-chip oscillator clock selected), the CM14 bit is set to 0 (low-speed on-chip oscillator on).
3. The OCD2 bit is automatically set to 1 (on-chip oscillator clock selected) if XIN clock oscillation stop is detected while bits OCD1 to OCD0 are set to 11b. If the OCD3 bit is set to 1 (XIN clock stops), the OCD2 bit remains unchanged even when set to 0 (XIN clock selected).
4. The OCD3 bit is enabled when the OCD0 bit is set to 1 (oscillation stop detection function enabled). In addition, the OCD3 bit cannot be used to confirm whether the XIN clock oscillation is stable.
5. The OCD3 bit remains 0 (XIN clock oscillates) if bits OCD1 to OCD0 are set to 00b.
6. Refer to **Figure 9.8 Procedure for Switching to XIN Clock when XIN Clock Re-Oscillates after Oscillation Stop is Detected** for the switching procedure when the XIN clock re-oscillates after detecting oscillation stop.

Set the PRC0 bit in the PRCR register to 1 (write enabled) before rewriting the OCD register.

9.2.5 High-Speed On-Chip Oscillator Control Register 7 (FRA7)

Address 0015h

Bit	b7	b6	b5	b4	b3	b2	b1	b0
Symbol	—	—	—	—	—	—	—	—
After Reset	When shipping							

Bit	Function	R/W
b7-b0	32 MHz frequency correction data is stored. The frequency can be adjusted by transferring this value to the FRA3 register and by transferring the correction value in the FRA6 register to the FRA1 register.	R

9.2.6 High-Speed On-Chip Oscillator Control Register 0 (FRA0)

Address 0023h

Bit	b7	b6	b5	b4	b3	b2	b1	b0
Symbol	—	—	—	—	FRA03	—	FRA01	FRA00
After Reset	0	0	0	0	0	0	0	0

Bit	Symbol	Bit Name	Function	R/W
b0	FRA00	High-speed on-chip oscillator enable bit	0: High-speed on-chip oscillator off 1: High-speed on-chip oscillator on	R/W
b1	FRA01	High-speed on-chip oscillator select bit ⁽¹⁾	0: Low-speed on-chip oscillator selected ⁽²⁾ 1: High-speed on-chip oscillator selected ⁽³⁾	R/W
b2	—	Reserved bit	Set to 0.	R/W
b3	FRA03	fOCO128 clock select bit	0: fOCO-S divided by 128 selected 1: fOCO-F divided by 128 selected	R/W
b4	—	Nothing is assigned. If necessary, set to 0. When read, the content is 0.		—
b5	—			
b6	—			
b7	—			

Notes:

- Change the FRA01 bit in the following conditions.
 - FRA00 = 1 (high-speed on-chip oscillator on)
 - The CM14 bit in the CM1 register = 0 (low-speed on-chip oscillator on)
- When setting the FRA01 bit to 0 (low-speed on-chip oscillator selected), do not set the FRA00 bit to 0 (high-speed on-chip oscillator off) at the same time. Set the FRA00 bit to 0 after setting the FRA01 bit to 0.
- When setting the FRA01 bit to 1 (high-speed on-chip oscillator selected) and stopping the low-speed on-chip oscillator, wait for one or more cycles of the low-speed on-chip oscillator and then set the CM14 bit in the CM1 register to 1 (low-speed on-chip oscillator off).

Set the PRC0 bit in the PRCR register to 1 (write enabled) before rewriting the FRA0 register.

9.2.7 High-Speed On-Chip Oscillator Control Register 1 (FRA1)

Address 0024h

Bit	b7	b6	b5	b4	b3	b2	b1	b0
Symbol	—	—	—	—	—	—	—	—
After Reset	When shipping							

Bit	Function	R/W
b7-b0	The frequency of the high-speed on-chip oscillator can be adjusted by setting as follows: 40 MHz: FRA1 = value after reset, FRA3 = value after reset 36.864 MHz: Transfer the value in the FRA4 register to the FRA1 register and the value in the FRA5 register to the FRA3 register. 32 MHz: Transfer the value in the FRA6 register to the FRA1 register and the value in the FRA7 register to the FRA3 register.	R/W

Set the PRC0 bit in the PRCR register to 1 (write enabled) before rewriting the FRA1 register.

Also, rewrite the FRA1 register when the FRA00 bit in the FRA0 register is set 0 (high-speed on-chip oscillator off).

9.2.8 High-Speed On-Chip Oscillator Control Register 2 (FRA2)

Address 0025h

Bit	b7	b6	b5	b4	b3	b2	b1	b0
Symbol	—	—	—	—	—	FRA22	FRA21	FRA20
After Reset	0	0	0	0	0	0	0	0

Bit	Symbol	Bit Name	Function	R/W
b0	FRA20	High-speed on-chip oscillator frequency switching bit	Division selection These bits select the division ratio for the high-speed on-chip oscillator clock. b2 b1 b0 0 0 0: Divide-by-2 mode 0 0 1: Divide-by-3 mode 0 1 0: Divide-by-4 mode 0 1 1: Divide-by-5 mode 1 0 0: Divide-by-6 mode 1 0 1: Divide-by-7 mode 1 1 0: Divide-by-8 mode 1 1 1: Divide-by-9 mode	R/W
b1	FRA21			R/W
b2	FRA22			R/W
b3	—	Reserved bits	Set to 0.	R/W
b4	—			
b5	—			
b6	—			
b7	—			

Set the PRC0 bit in the PRCR register to 1 (write enabled) before rewriting the FRA2 register.

9.2.9 High-Speed On-Chip Oscillator Control Register 4 (FRA4)

Address 0029h

Bit	b7	b6	b5	b4	b3	b2	b1	b0
Symbol	—	—	—	—	—	—	—	—
After Reset	When shipping							

Bit	Function	R/W
b7-b0	36.864 MHz frequency correction data is stored. The frequency can be adjusted by transferring this value to the FRA1 register and by transferring the correction value in the FRA5 register to the FRA3 register.	R

9.2.10 High-Speed On-Chip Oscillator Control Register 5 (FRA5)

Address 002Ah

Bit	b7	b6	b5	b4	b3	b2	b1	b0
Symbol	—	—	—	—	—	—	—	—
After Reset	When shipping							

Bit	Function	R/W
b7-b0	36.864 MHz frequency correction data is stored. The frequency can be adjusted by transferring this value to the FRA3 register and by transferring the correction value in the FRA4 register to the FRA1 register.	R

9.2.11 High-Speed On-Chip Oscillator Control Register 6 (FRA6)

Address 002Bh

Bit	b7	b6	b5	b4	b3	b2	b1	b0
Symbol	—	—	—	—	—	—	—	—
After Reset	When shipping							

Bit	Function	R/W
b7-b0	32 MHz frequency correction data is stored. The frequency can be adjusted by transferring this value to the FRA1 register and by transferring the correction value in the FRA7 register to the FRA3 register.	R

9.2.12 High-Speed On-Chip Oscillator Control Register 3 (FRA3)

Address 002Fh

Bit	b7	b6	b5	b4	b3	b2	b1	b0
Symbol	—	—	—	—	—	—	—	—
After Reset	When shipping							

Bit	Function	R/W
b7-b0	The frequency of the high-speed on-chip oscillator can be adjusted by setting as follows: 40 MHz: FRA1 = value after reset, FRA3 = value after reset 36.864 MHz: Transfer the value in the FRA4 register to the FRA1 register and the value in the FRA5 register to the FRA3 register. 32 MHz: Transfer the value in the FRA6 register to the FRA1 register and the value in the FRA7 register to the FRA3 register.	R/W

Set the PRC0 bit in the PRCR register to 1 (write enabled) before rewriting the FRA3 register.

Also, rewrite the FRA3 register when the FRA00 bit in the FRA0 register is set 0 (high-speed on-chip oscillator off).

9.2.13 Voltage Detect Register 2 (VCA2)

Address 0034h

Bit	b7	b6	b5	b4	b3	b2	b1	b0
Symbol	VCA27	VCA26	VCA25	—	—	—	—	VCA20
After Reset	0	0	0	0	0	0	0	0

The above applies when the LVDAS bit in the OFS register is set to 1.

After Reset	0	0	1	0	0	0	0	0
-------------	---	---	---	---	---	---	---	---

The above applies when the LVDAS bit in the OFS register is set to 0.

Bit	Symbol	Bit Name	Function	R/W
b0	VCA20	Internal power low consumption enable bit ⁽¹⁾	0: Low consumption disabled 1: Low consumption enabled ⁽²⁾	R/W
b1	—	Reserved bits	Set to 0.	R/W
b2	—			
b3	—			
b4	—			
b5	VCA25	Voltage detection 0 enable bit ⁽³⁾	0: Voltage detection 0 circuit disabled 1: Voltage detection 0 circuit enabled	R/W
b6	VCA26	Voltage detection 1 enable bit ⁽⁴⁾	0: Voltage detection 1 circuit disabled 1: Voltage detection 1 circuit enabled	R/W
b7	VCA27	Voltage detection 2 enable bit ⁽⁵⁾	0: Voltage detection 2 circuit disabled 1: Voltage detection 2 circuit enabled	R/W

Notes:

1. Use the VCA20 bit only when the MCU enters wait mode. To set the VCA20 bit, follow the procedure shown in **29.2.9 Reducing Internal Power Consumption Using VCA20 Bit**.
2. When the VCA20 bit is set to 1 (low consumption enabled), do not set the CM10 bit in the CM1 register to 1 (stop mode).
3. When writing to the VCA25 bit, set a value after reset.
4. To use the voltage detection 1 interrupt or the VW1C3 bit in the VW1C register, set the VCA26 bit to 1. After the VCA26 bit is set to 1 from 0, allow td(E-A) to elapse before the voltage detection 1 circuit starts operation.
5. To use the voltage detection 2 interrupt or the VCA13 bit in the VCA1 register, set the VCA27 bit to 1. After the VCA27 bit is set to 1 from 0, allow td(E-A) to elapse before the voltage detection 2 circuit starts operation.

Set the PRC3 bit in the PRCR register to 1 (write enabled) before rewriting the VCA2 register.

The clocks generated by the clock generation circuits are described below.

9.3 XIN Clock

The XIN clock is supplied by the XIN clock oscillation circuit. This clock is used as the clock source for the CPU and peripheral function clocks. The XIN clock oscillation circuit is configured by connecting a resonator between pins XIN and XOUT. The XIN clock oscillation circuit includes an on-chip feedback resistor, which is disconnected from the oscillation circuit in stop mode in order to reduce the amount of power consumed by the chip. The XIN clock oscillation circuit may also be configured by feeding an externally generated clock to the XOUT pin.

Figure 9.3 shows Examples of XIN Clock Connection Circuit.

During and after a reset, the XIN clock stops.

After setting the CM13 bit in the CM1 register to 1 (XIN-XOUT pin), the XIN clock starts oscillating when the CM05 bit in the CM0 register is set to 0 (XIN clock oscillates). After the XIN clock oscillation stabilizes, the XIN clock is used as the CPU clock source when the OCD2 bit in the OCD register is set to 0 (XIN clock selected).

The power consumption can be reduced by setting the CM05 bit in the CM0 register to 1 (XIN clock stops) if the OCD2 bit is set to 1 (on-chip oscillator clock selected).

When an externally generated clock is input to the XOUT pin, the XIN clock does not stop even if the CM05 bit is set to 1. If necessary, use an external circuit to stop the clock.

In stop mode, all clocks including the XIN clock stop. Refer to **9.6 Power Control** for details.

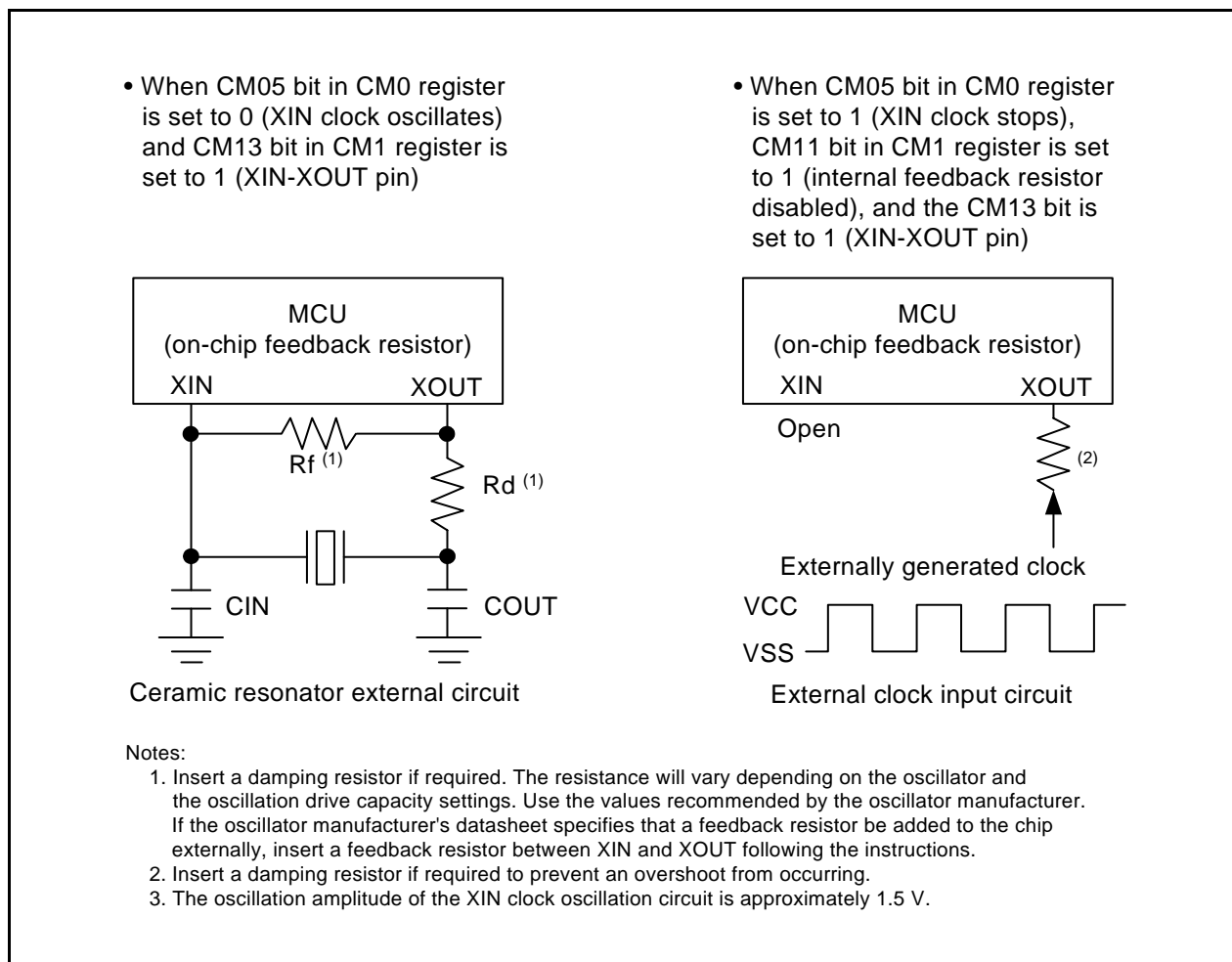

Figure 9.3 Examples of XIN Clock Connection Circuit

9.4 On-Chip Oscillator Clock

The on-chip oscillator clock is supplied by the on-chip oscillator (high-speed on-chip oscillator or low-speed on-chip oscillator). This clock is selected by the FRA01 bit in the FRA0 register.

9.4.1 Low-Speed On-Chip Oscillator Clock

The clock generated by the low-speed on-chip oscillator is used as the clock source for the CPU clock, peripheral function clock, fOCO, fOCO-S, and fOCO128.

After a reset, the on-chip oscillator clock generated by the low-speed on-chip oscillator divided by 1 (no division) is selected as the CPU clock.

If the XIN clock stops oscillating when bits OCD1 to OCD0 in the OCD register are set to 11b, the low-speed on-chip oscillator automatically starts operating and supplies the necessary clock for the MCU.

The frequency of the low-speed on-chip oscillator varies depending on the supply voltage and the operating ambient temperature. Application products must be designed with sufficient margin to allow for frequency changes.

9.4.2 High-Speed On-Chip Oscillator Clock

The clock generated by the high-speed on-chip oscillator is used as the clock source for the CPU clock, peripheral function clock, fOCO, fOCO-F, fOCO40M, and fOCO128.

After a reset, the on-chip oscillator clock generated by the high-speed on-chip oscillator stops. Oscillation is started by setting the FRA00 bit in the FRA0 register to 1 (high-speed on-chip oscillator on).

Frequency correction data is stored in registers FRA4 to FRA7.

To adjust the frequency of the high-speed on-chip oscillator clock to 36.864 MHz, first transfer the correction value in the FRA4 register to the FRA1 register and the correction value in the FRA5 register to the FRA3 register before using the values. This enables the setting errors of bit rates such as 9600 bps and 38400 bps to be 0% when the serial interface is used in UART mode (refer to **Tables 21.8** and **22.8 Bit Rate Setting Example in UART Mode**).

To adjust the frequency of the high-speed on-chip oscillator clock to 32 MHz, first transfer the correction value in the FRA6 register to the FRA1 register and the correction value in the FRA7 register to the FRA3 register before using the values.

9.5 CPU Clock and Peripheral Function Clock

There are a CPU clock to operate the CPU and a peripheral function clock to operate the peripheral functions. Refer to **Figure 9.1 Clock Generation Circuit**.

9.5.1 System Clock

The system clock is the clock source for the CPU and peripheral function clocks. The XIN clock or the on-chip oscillator clock can be selected.

9.5.2 CPU Clock

The CPU clock is an operating clock for the CPU and the watchdog timer.

The system clock divided by 1 (no division), 2, 4, 8, or 16 is used as the CPU clock. Use the CM06 bit in the CM0 register and bits CM16 and CM17 in the CM1 register to select the value of the division.

After a reset, the low-speed on-chip oscillator clock divided by 1 (no division) is used as the CPU clock.

When the MCU enters stop mode, the CM06 bit is set to 1 (divide-by-8 mode). To enter stop mode, set the CM35 bit in the CM3 register to 0 (settings of CM06 in CM0 register and bits CM16 and CM17 in CM1 register enabled).

9.5.3 Peripheral Function Clock (f1, f2, f4, f8, and f32)

The peripheral function clock is an operating clock for the peripheral functions.

The f_i ($i = 1, 2, 4, 8, \text{ and } 32$) clock is generated by the system clock divided by i . It is used for timers RA, RB, RC, RD, the serial interface, and the A/D converter.

If the MCU enters wait mode after the CM02 bit in the CM0 register is set to 1 (peripheral function clock stops in wait mode), the f_i clock stops.

9.5.4 fOCO

fOCO is an operating clock for the peripheral functions.

The frequency of fOCO is the frequency of the on-chip oscillator clock selected by the FRA01 bit in the FRA0 register.

For the high-speed on-chip oscillator, its frequency is the frequency divided by the divide ratio selected by bits FRA20 to FRA22 in the FRA2 register. fOCO can be used for timer RA.

In wait mode, the fOCO clock does not stop.

9.5.5 fOCO40M

fOCO40M is used as the count source for timers RC and RD.

This clock is generated by the high-speed on-chip oscillator and supplied by setting the FRA00 bit to 1.

In wait mode, the fOCO40M clock does not stop.

This clock can be used with supply voltage $VCC = 2.7$ to 5.5 V.

9.5.6 fOCO-F

fOCO-F is used as the count source for timers RC, RD and the A/D converter.

fOCO-F is a clock generated by the high-speed on-chip oscillator and divided by i ($i = 2, 3, 4, 5, 6, 7, 8, \text{ and } 9$; divide ratio selected by the FRA2 register). This clock is supplied by setting the FRA00 bit to 1.

In wait mode, the fOCO-F clock does not stop.

9.5.7 fOCO-S

fOCO-S is an operating clock for the voltage detection circuit.

This clock is generated by the low-speed on-chip oscillator and supplied by setting the CM14 bit to 0 (low-speed on-chip oscillator on).

In wait mode, the fOCO-S clock does not stop.

9.5.8 fOCO128

fOCO128 is a clock generated by dividing fOCO-S or fOCO-F by 128. When the FRA03 bit is set to 0, fOCO-S divided by 128 is selected. When this bit is set to 1, fOCO-F divided by 128 is selected.

fOCO128 is configured as the capture signal used in the TRCGRA register for timer RC and timer RD0 for timer RD.

9.5.9 fOCO-WDT

fOCO-WDT is an operating clock for the watchdog timer.

This clock is generated by the low-speed on-chip oscillator for the watchdog timer and supplied by setting the CSPRO bit in the CSPR register to 1 (count source protect mode enabled).

In count source protection mode for the watchdog timer, the fOCO-WDT clock does not stop.

9.6 Power Control

There are three power control modes. All modes other than wait mode and stop mode are referred to as standard operating mode.

9.6.1 Standard Operating Mode

Standard operating mode is further separated into three modes.

In standard operating mode, the CPU and peripheral function clocks are supplied to operate the CPU and the peripheral functions. Power consumption control is enabled by controlling the CPU clock frequency. The higher the CPU clock frequency, the more processing power increases. The lower the CPU clock frequency, the more power consumption decreases. If unnecessary oscillator circuits stop, power consumption is further reduced.

Before the clock sources for the CPU clock can be switched over, the new clock source needs to be oscillating and stable. Allow sufficient wait time in a program until oscillation stabilizes before switching the clock.

Table 9.2 Settings and Modes of Clock Associated Bits

Modes		OCD Register	CM1 Register			CM0 Register		FRA0 Register	
		OCD2	CM17,C M16	CM14	CM13	CM06	CM05	FRA01	FRA00
High-speed clock mode	No division	0	00b	–	1	0	0	–	–
	Divide-by-2	0	01b	–	1	0	0	–	–
	Divide-by-4	0	10b	–	1	0	0	–	–
	Divide-by-8	0	–	–	1	1	0	–	–
	Divide-by-16	0	11b	–	1	0	0	–	–
High-speed on-chip oscillator mode	No division	1	00b	–	–	0	–	1	1
	Divide-by-2	1	01b	–	–	0	–	1	1
	Divide-by-4	1	10b	–	–	0	–	1	1
	Divide-by-8	1	–	–	–	1	–	1	1
	Divide-by-16	1	11b	–	–	0	–	1	1
Low-speed on-chip oscillator mode	No division	1	00b	0	–	0	–	0	–
	Divide-by-2	1	01b	0	–	0	–	0	–
	Divide-by-4	1	10b	0	–	0	–	0	–
	Divide-by-8	1	–	0	–	1	–	0	–
	Divide-by-16	1	11b	0	–	0	–	0	–

–: Indicates that either 0 or 1 can be set.

9.6.1.1 High-Speed Clock Mode

The XIN clock divided by 1 (no division), 2, 4, 8, or 16 is used as the CPU clock. If the CM14 bit is set to 0 (low-speed on-chip oscillator on) or the FRA00 bit in the FRA0 register is set to 1 (high-speed on-chip oscillator on), fOCO can be used for timer RA.

Also, if the FRA00 bit is set to 1, fOCO40M can be used for timer RC and timer RD.

If the CM14 bit is set to 0 (low-speed on-chip oscillator on), fOCO-S can be used for the voltage detection circuit.

9.6.1.2 High-Speed On-Chip Oscillator Mode

The high-speed on-chip oscillator is used as the on-chip oscillator clock when the FRA00 bit in the FRA0 register is set to 1 (high-speed on-chip oscillator on) and the FRA01 bit in the FRA0 register is set to 1. The on-chip oscillator divided by 1 (no division), 2, 4, 8, or 16 is used as the CPU clock. If the FRA00 bit is set to 1, fOCO40M can be used for timer RC and timer RD.

Also, if the CM14 bit is set to 0 (low-speed on-chip oscillator on), fOCO-S can be used for the voltage detection circuit.

9.6.1.3 Low-Speed On-Chip Oscillator Mode

If the CM14 bit in the CM1 register is set to 0 (low-speed on-chip oscillator on) and the FRA01 bit in the FRA0 register is set to 0, the low-speed on-chip oscillator is used as the on-chip oscillator clock. At this time, the on-chip oscillator clock divided by 1 (no division), 2, 4, 8 or 16 is used as the CPU clock. The on-chip oscillator clock is also the clock source for the peripheral function clocks. If the FRA00 bit is set to 1, fOCO40M can be used for timer RC and timer RD.

Also, if the CM14 bit is set to 0 (low-speed on-chip oscillator on), fOCO-S can be used for the voltage detection circuit.

In this mode, low consumption operation is enabled by stopping the XIN clock and the high-speed on-chip oscillator, and by setting the FMR27 bit in the FMR2 register to 1 (low-current-consumption read mode enabled). When the CPU clock is set to the low-speed on-chip oscillator clock divided by 4, 8, or 16, low-current-consumption read mode can be used. After setting the divide ratio of the CPU clock, set the FMR27 bit to 1.

To enter wait mode from low-speed clock mode, lower consumption current in wait mode is enabled by setting the VCA20 bit in the VCA2 register to 1 (internal power low consumption enabled).

To reduce the power consumption, refer to **29. Reducing Power Consumption**.

9.6.2 Wait Mode

Since the CPU clock stops in wait mode, the CPU operating with the CPU clock and the watchdog timer when count source protection mode is disabled stop. Since the XIN clock and on-chip oscillator clock do not stop, the peripheral functions using these clocks continue operating.

9.6.2.1 Peripheral Function Clock Stop Function

If the CM02 bit is set to 1 (peripheral function clock stops in wait mode), the f1, f2, f4, f8, and f32 clocks stop in wait mode. This reduces power consumption.

9.6.2.2 Entering Wait Mode

The MCU enters wait mode by executing the WAIT instruction or setting the CM30 bit in the CM3 register to 1 (MCU enters wait mode).

When the OCD2 bit in the OCD register is set to 1 (on-chip oscillator selected as system clock), set the OCD1 bit in the OCD register to 0 (oscillation stop detection interrupt disabled) before executing the WAIT instruction or setting the CM30 bit in the CM3 register to 1 (MCU enters wait mode).

If the MCU enters wait mode while the OCD1 bit is set to 1 (oscillation stop detection interrupt enabled), current consumption is not reduced because the CPU clock does not stop.

When entering wait mode, set the FMR01 bit in the FMR0 register to 0 (CPU rewrite mode disabled) and the FMR27 bit to 0 (low-current-consumption read mode disabled) before entering the mode.

Do not enter wait mode while the FMR01 bit is 1 (CPU rewrite mode enabled) or the FMR27 bit is 1 (lowcurrent-consumption read mode enabled).

To enter wait mode by setting the CM30 bit to 1, set the I flag to 0 (maskable interrupt disabled). To enter wait mode using the WAIT instruction, set the I flag to 1 (maskable interrupt enabled).

9.6.2.3 Reducing Internal Power Using VCA20 Bit

When the MCU enters wait mode using low-speed clock mode or low-speed on-chip oscillator mode, internal power consumption can be reduced using the VCA20 bit in the VCA2 register. To enable internal power consumption using the VCA20 bit, follow the procedure shown in 29.2.9 Reducing Internal Power Consumption Using VCA20 Bit.

9.6.2.4 Pin Status in Wait Mode

The I/O port retains the status immediately before the MCU enters wait mode.

9.6.2.5 Exiting Wait Mode

The MCU exits wait mode by a reset or peripheral function interrupt.

The peripheral function interrupts are affected by the CM02 bit. When the CM02 bit is set to 0 (peripheral function clock does not stop in wait mode), the peripheral function interrupts other than A/D conversion interrupts can be used to exit wait mode. When the CM02 bit is set to 1 (peripheral function clock stops in wait mode), the peripheral functions using the peripheral function clock stop and the peripheral functions operating with external signals or the on-chip oscillator clock can be used to exit wait mode.

Table 9.3 lists Interrupts to Exit Wait Mode and Usage Conditions.

Table 9.3 Interrupts to Exit Wait Mode and Usage Conditions

Interrupt	CM02 = 0	CM02 = 1
Serial interface interrupt	Usable when operating with internal or external clock	Usable when operating with external clock
Synchronous serial communication unit interrupt	Usable in all modes	(Do not use)
Key input interrupt	Usable	Usable
A/D conversion interrupt	(Do not enter wait mode during A/D conversion)	(Do not enter wait mode during A/D conversion)
Timer RA interrupt	Usable in all modes	Usable if there is no filter in event counter mode. Usable by selecting fOCO as count source.
Timer RB interrupt	Usable in all modes	Usable by selecting fOCO as timer RA count source and timer RA underflow as timer RB count source
Timer RC interrupt	Usable in all modes	(Do not use)
Timer RD interrupt	Usable in all modes	Usable by selecting fOCO40M as count source
$\overline{\text{INT}}$ interrupt	Usable	Usable ($\overline{\text{INT0}}$ to $\overline{\text{INT1}}$, $\overline{\text{INT3}}$ can be used if there is no filter.)
Voltage monitor 1 interrupt	Usable	Usable
Voltage monitor 2 interrupt	Usable	Usable
Oscillation stop detection interrupt	Usable	(Do not use)

9.6.2.6 Exiting Wait Mode after CM30 Bit in CM3 Register is Set to 1 (MCU Enters Wait Mode)

Figure 9.4 shows the Time from Wait Mode to First Instruction Execution following Exit after CM30 Bit in CM3 Register is Set to 1 (MCU Enters Wait Mode).

To use a peripheral function interrupt to exit wait mode, set up the following before setting the CM30 bit to 1.

- (1) Set the I flag to 0 (maskable interrupt disabled).
- (2) Set the interrupt priority level in bits ILVL2 to ILVL0 in the interrupt control registers of the peripheral function interrupts to be used for exiting wait mode. Set bits ILVL2 to ILVL0 of the peripheral function interrupts that are not to be used for exiting wait mode to 000b (interrupt disabled).
- (3) Operate the peripheral function to be used for exiting wait mode.

When the MCU exits by a peripheral function interrupt, the time (number of cycles) between interrupt request generation and interrupt routine execution is determined by the settings of the FMSTP bit in the FMR0 register and the VCA20 bit in the VCA2 register, as shown in Figure 9.4.

The clock set by bits CM35, CM36, and CM37 in the CM3 register is used as the CPU clock when the MCU exits wait mode by a peripheral function interrupt. At this time, the CM06 bit in the CM0 register and bits CM16 and CM17 in the CM1 register automatically change.

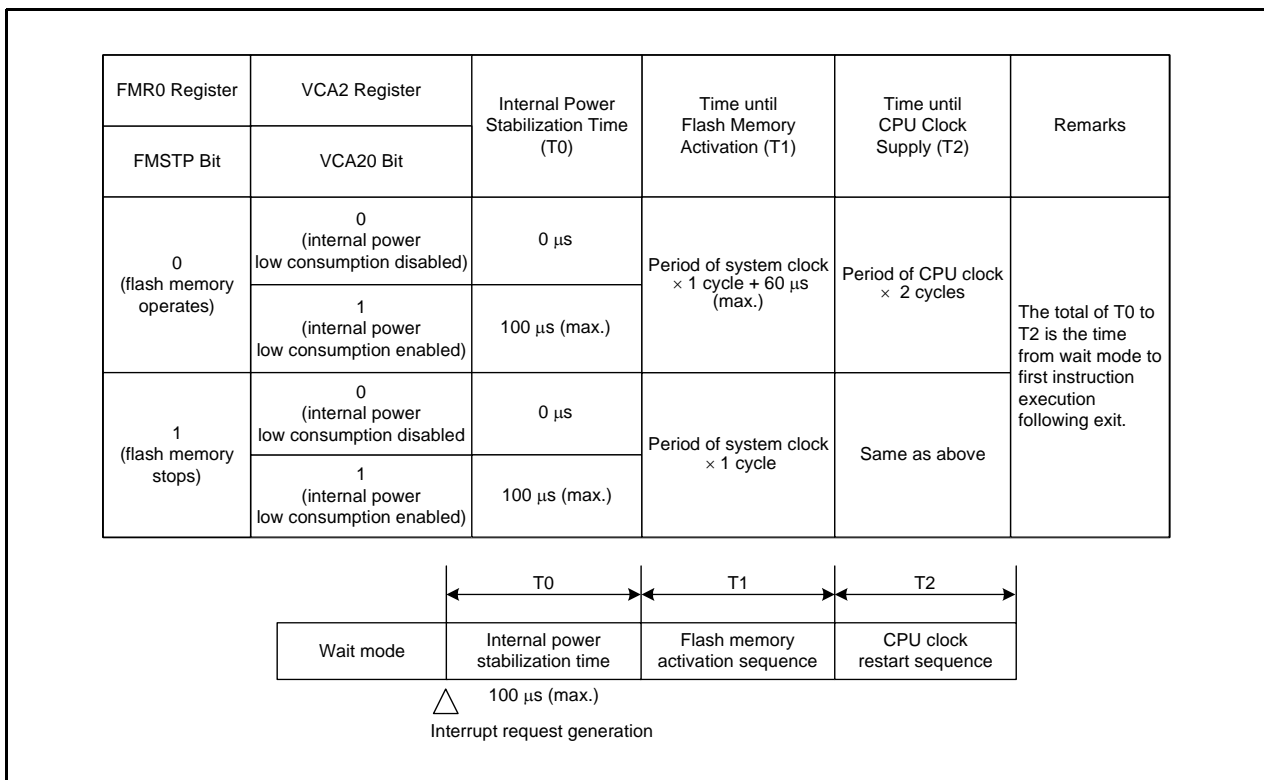

Figure 9.4 Time from Wait Mode to First Instruction Execution following Exit after CM30 Bit in CM3 Register is Set to 1 (MCU Enters Wait Mode)

9.6.2.7 Exiting Wait Mode after WAIT Instruction is Executed

Figure 9.5 shows the Time from Wait Mode to Interrupt Routine Execution after WAIT instruction is Executed. To use a peripheral function interrupt to exit wait mode, set up the following before executing the WAIT instruction.

- (1) Set the interrupt priority level in bits ILVL2 to ILVL0 of the peripheral function interrupts to be used for exiting stop mode. Set bits ILVL2 to ILVL0 of the peripheral function interrupts that are not to be used for exiting stop mode to 000b (interrupt disabled).
- (2) Set the I flag to 1.
- (3) Operate the peripheral function to be used for exiting stop mode.

When the MCU exits by a peripheral function interrupt, the time (number of cycles) between interrupt request generation and interrupt routine execution is determined by the settings of the FMSTP bit in the FMR0 register and the VCA20 bit in the VCA2 register, as shown in Figure 9.5.

The clock set by bits CM35, CM36, and CM37 in the CM3 register is used as the CPU clock when the MCU exits wait mode by a peripheral function interrupt. At this time, the CM06 bit in the CM0 register and bits CM16 and CM17 in the CM1 register automatically change.

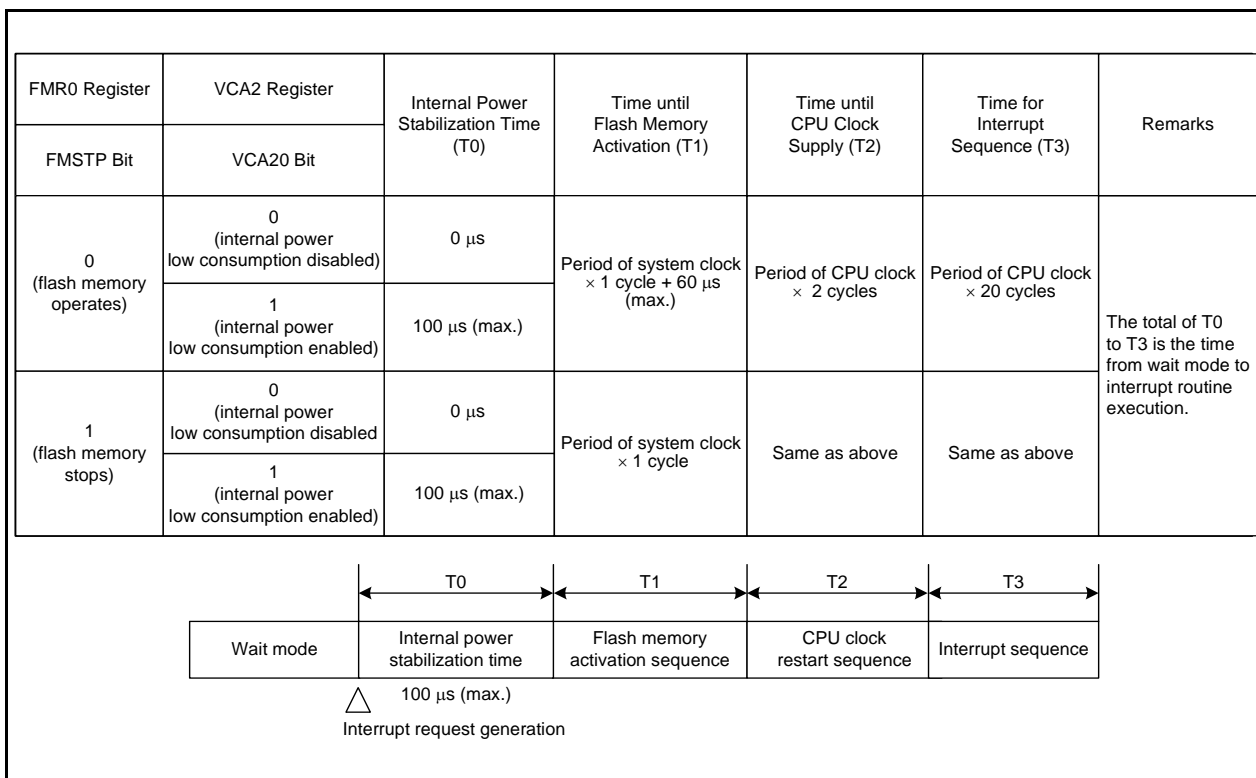

Figure 9.5 Time from Wait Mode to Interrupt Routine Execution after WAIT instruction is Executed

9.6.3 Stop Mode

Since all oscillator circuits except fOCO-WDT stop in stop mode, the CPU and peripheral function clocks stop and the CPU and the peripheral functions operating with these clocks also stop. The least power required to operate the MCU is in stop mode. If the voltage applied to the VCC pin is VRAM or more, the contents of internal RAM is retained.

The peripheral functions clocked by external signals continue operating.

Table 9.4 lists Interrupts to Exit Stop Mode and Usage Conditions.

Table 9.4 Interrupts to Exit Stop Mode and Usage Conditions

Interrupt	Usage Conditions
Key input interrupt	Usable
$\overline{\text{INT0}}$ to $\overline{\text{INT1}}$, $\overline{\text{INT3}}$ interrupt	Usable if there is no filter
Timer RA interrupt	Usable if there is no filter when external pulse is counted in event counter mode
Serial interface interrupt	When external clock selected
Voltage monitor 1 interrupt	Usable in digital filter disabled mode (VW1C1 bit in VW1C register is set to 1)
Voltage monitor 2 interrupt	Usable in digital filter disabled mode (VW2C1 bit in VW2C register is set to 1)

9.6.3.1 Entering Stop Mode

The MCU enters stop mode when the CM10 bit in the CM1 register is set to 1 (all clocks stop). At the same time, the CM06 bit in the CM0 register is set to 1 (divide-by-8 mode).

To use stop mode, set the following before the MCU enters stop mode:

- Bits OCD1 to OCD0 in the OCD register = 00b
- CM35 bit in CM3 register = 0 (settings of CM06 bit in CM0 register and bits CM16 and CM17 in CM1 register enabled)

Enter stop mode after setting the FMR27 bit to 0 (low-current-consumption read mode disabled). Do not enter stop mode while the FMR27 bit is 1 (low-current-consumption read mode enabled).

9.6.3.2 Pin Status in Stop Mode

The I/O port retains the status immediately before the MCU enters stop mode.

However, when the CM13 bit in the CM1 register is set to 1 (XIN-XOUT pin), pins XIN (P4_6) and XOUT (P4_7) are set to high impedance.

9.6.3.3 Exiting Stop Mode

The MCU exits stop mode by a reset or peripheral function interrupt.

Figure 9.6 shows the Time from Stop Mode to Interrupt Routine Execution.

To use a peripheral function interrupt to exit stop mode, set up the following before setting the CM10 bit to 1.

- (1) Set the interrupt priority level in bits ILVL2 to ILVL0 of the peripheral function interrupts to be used for exiting stop mode. Set bits ILVL2 to ILVL0 of the peripheral function interrupts that are not to be used for exiting stop mode to 000b (interrupt disabled).
- (2) Set the I flag to 1.
- (3) Operate the peripheral function to be used for exiting stop mode.

When the MCU exits stop mode by a peripheral function interrupt, the interrupt sequence is executed when an interrupt request is generated and the CPU clock supply starts.

The clock used immediately before stop mode divided by 8 is used as the CPU clock when the MCU exits stop mode by a peripheral function interrupt. To enter stop mode, set the CM35 bit in the CM3 register to 0 (settings of CM06 bit in CM0 register and bits CM16 and CM17 in CM1 register enabled)

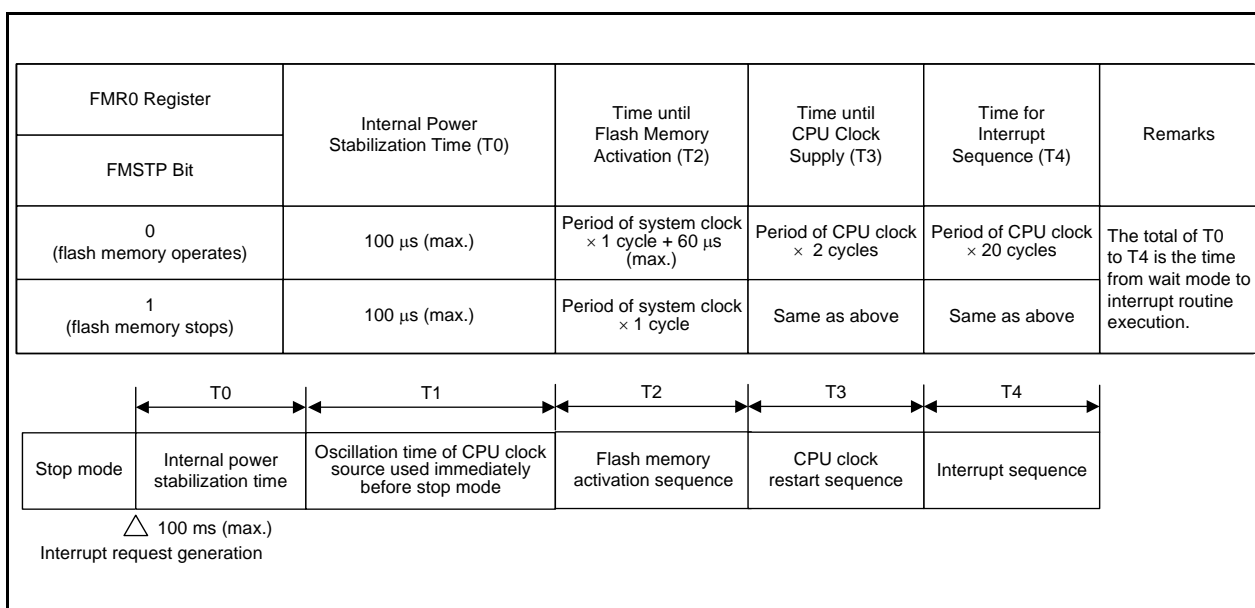

Figure 9.6 Time from Stop Mode to Interrupt Routine Execution

Figure 9.7 shows the State Transitions in Power Control Mode.

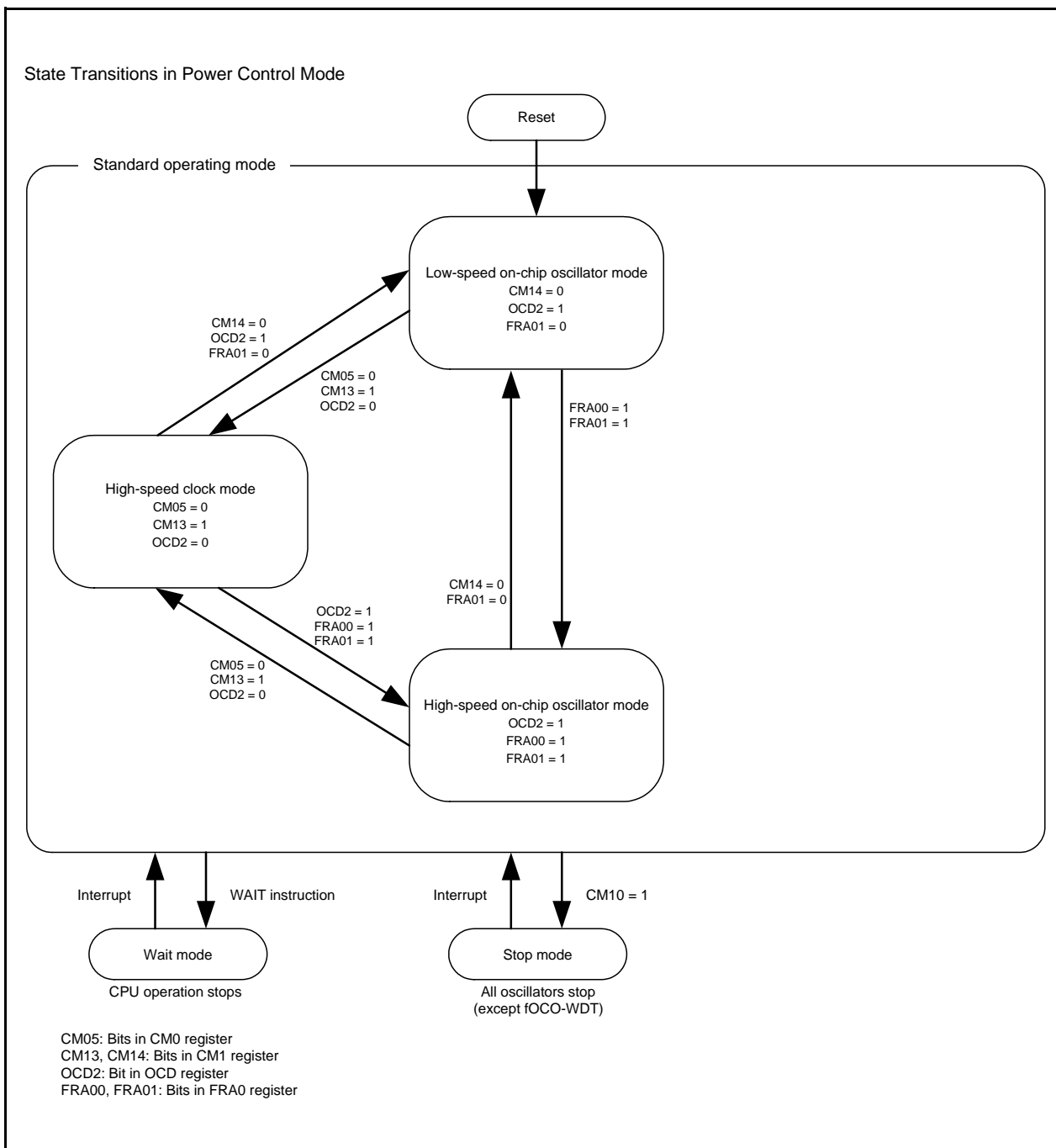

Figure 9.7 State Transitions in Power Control Mode

9.7 Oscillation Stop Detection Function

The oscillation stop detection function detects the stop of the XIN clock oscillating circuit.

The oscillation stop detection function can be enabled and disabled by the OCD0 bit in the OCD register.

Table 9.5 lists the Specifications of Oscillation Stop Detection Function.

When the XIN clock is the CPU clock source and bits OCD1 to OCD0 are set to 11b, the MCU is placed in the following state if the XIN clock stops.

- OCD2 bit in OCD register = 1 (on-chip oscillator clock selected)
- OCD3 bit in OCD register = 1 (XIN clock stops)
- CM14 bit in CM1 register = 0 (low-speed on-chip oscillator oscillates)
- Oscillation stop detection interrupt request is generated

Table 9.5 Specifications of Oscillation Stop Detection Function

Item	Specification
Oscillation stop detection clock and frequency bandwidth	$f(\text{XIN}) \geq 2 \text{ MHz}$
Enabled condition for oscillation stop detection function	Bits OCD1 to OCD0 set to 11b
Operation at oscillation stop detection	Oscillation stop detection interrupt generated

9.7.1 How to Use Oscillation Stop Detection Function

- The oscillation stop detection interrupt shares a vector with the voltage monitor 1 interrupt, the voltage monitor 2 interrupt, and the watchdog timer interrupt. To use the oscillation stop detection interrupt and watchdog timer interrupt, the interrupt source needs to be determined.
Table 9.6 lists the Determination of Interrupt Sources for Oscillation Stop Detection, Watchdog Timer, Voltage Monitor 1, or Voltage Monitor 2 Interrupt. Figure 9.9 shows an Example of Determining Interrupt Sources for Oscillation Stop Detection, Watchdog Timer, Voltage Monitor 1, or Voltage Monitor 2 Interrupt.
- When the XIN clock restarts after oscillation stop, switch the XIN clock to the clock source for the CPU clock and the peripheral functions by a program.
Figure 9.8 shows the Procedure for Switching to XIN Clock when XIN Clock Re-Oscillates after Oscillation Stop is Detected.
- To enter wait mode while the oscillation stop detection function is used, set the CM02 bit to 0 (peripheral function clock does not stop in wait mode).
- Since the oscillation stop detection function is a function for cases where the XIN clock is stopped by an external cause, set bits OCD1 to OCD0 to 00b to stop or start the XIN clock by a program (select stop mode or change the CM05 bit).
- This function cannot be used when the XIN clock frequency is below 2 MHz. In this case, set bits OCD1 to OCD0 to 00b.
- To use the low-speed on-chip oscillator clock as the clock source for the CPU clock and the peripheral functions after detecting the oscillation stop, set the FRA01 bit in the FRA0 register to 0 (low-speed on-chip oscillator selected) and bits OCD1 to OCD0 to 11b.
To use the high-speed on-chip oscillator clock as the clock source for the CPU clock and the peripheral functions after detecting the oscillation stop, first set the FRA00 bit to 1 (high-speed on-chip oscillator oscillates) and the FRA01 bit to 1 (high-speed on-chip oscillator selected). Then set bits OCD1 to OCD0 to 11b.

Table 9.6 Determination of Interrupt Sources for Oscillation Stop Detection, Watchdog Timer, Voltage Monitor 1, or Voltage Monitor 2 Interrupt

Generated Interrupt Source	Bit Indicating Interrupt Source
Oscillation stop detection ((a) or (b))	(a) OCD3 bit in OCD register = 1
	(b) OCD1 to OCD0 bits in OCD register = 11b and OCD2 bit = 1
Watchdog timer	VW2C3 bit in VW2C register = 1
Voltage monitor 1	VW1C2 bit in VW1C register = 1
Voltage monitor 2	VW2C2 bit in VW2C register = 1

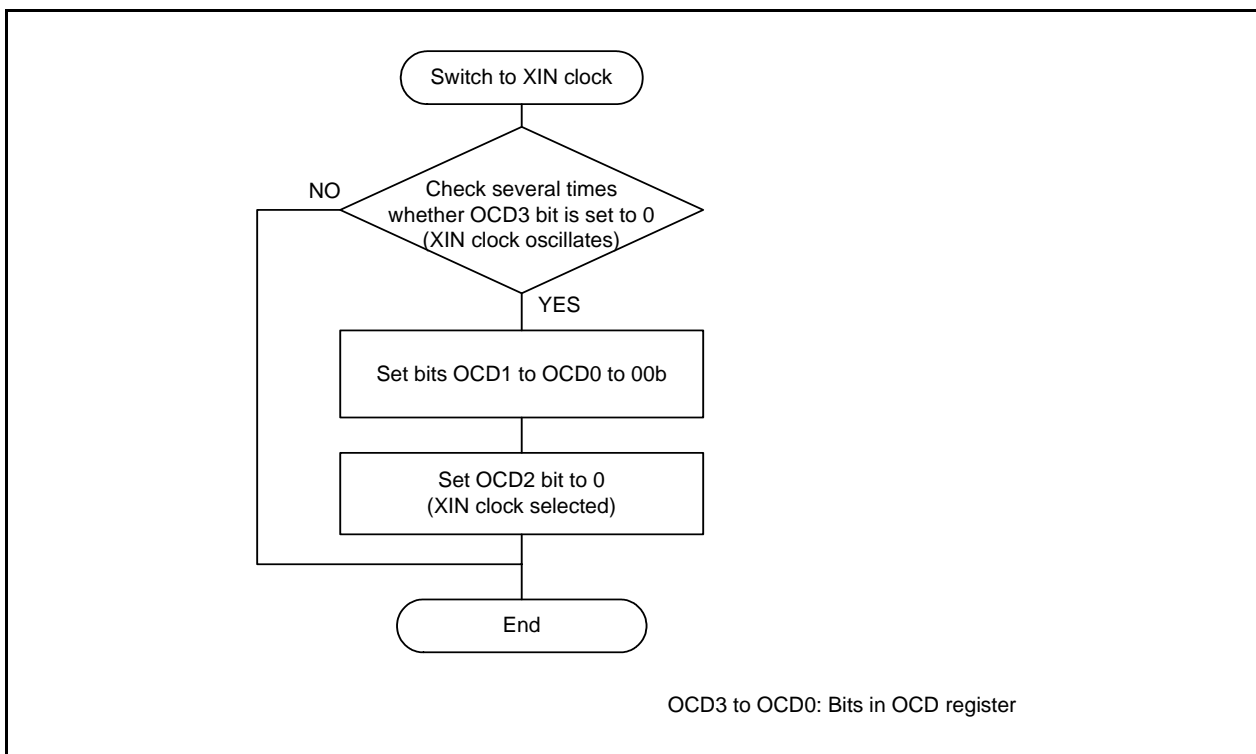

Figure 9.8 Procedure for Switching to XIN Clock when XIN Clock Re-Oscillates after Oscillation Stop is Detected

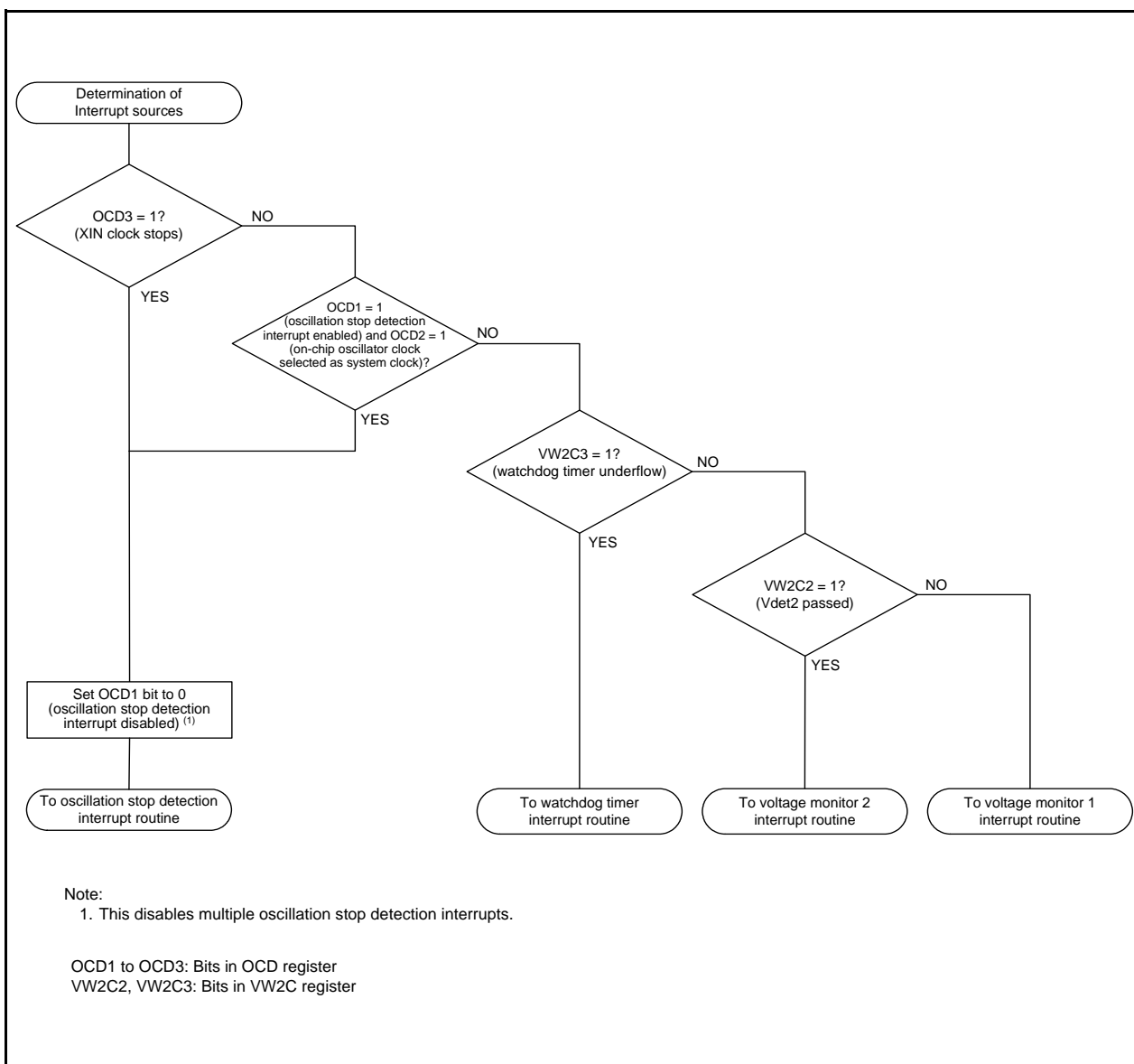

Figure 9.9 Example of Determining Interrupt Sources for Oscillation Stop Detection, Watchdog Timer, Voltage Monitor 1, or Voltage Monitor 2 Interrupt

9.8 Notes on Clock Generation Circuit

9.8.1 Stop Mode

To enter stop mode, set the FMR01 bit in the FMR0 register to 0 (CPU rewrite mode disabled) and then the CM10 bit in the CM1 register to 1 (stop mode). An instruction queue pre-reads 4 bytes from the instruction which sets the CM10 bit to 1 (stop mode) and the program stops.

Insert at least four NOP instructions following the JMP.B instruction after the instruction which sets the CM10 bit to 1.

- Program example to enter stop mode

```

BCLR      1,FMR0      ; CPU rewrite mode disabled
BCLR      7,FMR2      ; Low-current-consumption read mode disabled
BSET      0,PRCR      ; Writing to CM1 register enabled
FSET      I           ; Interrupt enabled
BSET      0,CM1       ; Stop mode
JMP.B     LABEL_001
LABEL_001:
NOP
NOP
NOP
NOP

```

9.8.2 Wait Mode

When entering wait mode, set the FMR01 bit in the FMR0 register to 0 (CPU rewrite mode disabled) and the FMR27 bit to 0 (low-current-consumption read mode disabled) before entering the mode. Do not enter wait mode while the FMR01 bit is 1 (CPU rewrite mode enabled) or the FMR27 bit is 1 (low-current-consumption read mode enabled).

To enter wait mode by setting the CM30 bit to 1, set the I flag to 0 (maskable interrupt disabled).

To enter wait mode using the WAIT instruction, set the I flag to 1 (maskable interrupt enabled). An instruction queue pre-reads 4 bytes from the instruction to set the CM30 bit to 1 (MCU enters wait mode) or the WAIT instruction, and then the program stops. Insert at least four NOP instructions after the instruction to set the CM30 bit to 1 (MCU enters wait mode) or the WAIT instruction.

- Program example to execute the WAIT instruction

```

BCLR      1,FMR0      ; CPU rewrite mode disabled
BCLR      7,FMR2      ; Low-current-consumption read mode disabled
FSET      I           ; Interrupt enabled
WAIT      ; Wait mode
NOP
NOP
NOP
NOP

```

- Program example to execute the instruction to set the CM30 bit to 1

```

BCLR      1, FMR0     ; CPU rewrite mode disabled
BCLR      7, FMR2     ; Low-current-consumption read mode disabled
BSET      0, PRCR     ; Writing to CM3 register enabled
FCLR      I           ; Interrupt disabled
BSET      0, CM3      ; Wait mode
NOP
NOP
NOP
NOP
BCLR      0, PRCR     ; Writing to CM3 register disabled
FSET      I           ; Interrupt enabled

```

9.8.3 Reducing Internal Power Using VCA20 Bit

Set the VCA20 bit to 1 in low-speed clock mode or low-speed on-chip oscillator mode before entering wait mode.

To enter wait mode by setting the CM30 bit in the CM3 register to 1 (MCU enters wait mode), follow the procedure shown in Figure 9.1 to set the procedure for reducing internal power consumption using the VCA20 bit.

To enter wait mode by executing WAIT instruction, follow the procedure shown in Figure 9.2 to set the procedure for reducing internal power consumption using the VCA20 bit.

9.8.4 Oscillation Stop Detection Function

Since the oscillation stop detection function cannot be used if the XIN clock frequency is below 2 MHz, set bits OCD1 to OCD0 to 00b. In addition, the OCD3 bit cannot be used to confirm whether the XIN clock oscillation is stable.

9.8.5 Oscillation Circuit Constants

Consult the oscillator manufacturer to determine the optimal oscillation circuit constants for the user system.

10. Protection

The protection function protects important registers from being easily overwritten if a program runs out of control.

The registers protected by the PRCR register are as follows:

- Registers protected by PRC0 bit: Registers CM0, CM1, CM3, OCD, FRA0, FRA1, FRA2, and FRA3
- Registers protected by PRC1 bit: Registers PM0 and PM1
- Registers protected by PRC2 bit: PD0 register
- Registers protected by PRC3 bit: Registers OCVREFCR, VCA2, VD1LS, VW0C, VW1C, and VW2C

10.1 Register

10.1.1 Protect Register (PRCR)

Address 000Ah

Bit	b7	b6	b5	b4	b3	b2	b1	b0
Symbol	—	—	—	—	PRC3	PRC2	PRC1	PRC0
After Reset	0	0	0	0	0	0	0	0

Bit	Symbol	Bit Name	Function	R/W
b0	PRC0	Protect bit 0	Enables writing to registers CM0, CM1, CM3, OCD, FRA0, FRA1, FRA2, and FRA3. 0: Write disabled 1: Write enabled (2)	R/W
b1	PRC1	Protect bit 1	Enables writing to registers PM0 and PM1. 0: Write disabled 1: Write enabled (2)	R/W
b2	PRC2	Protect bit 2	Enables writing to the PD0 register. 0: Write disabled 1: Write enabled (1)	R/W
b3	PRC3	Protect bit 3	Enables writing to registers OCVREFCR, VCA2, VD1LS, VW0C, VW1C, and VW2C. 0: Write disabled 1: Write enabled (2)	R/W
b4	—	Reserved bits	Set to 0.	R/W
b5	—			
b6	—			
b7	—	Nothing is assigned. If necessary, set to 0. When read, the content is 0.		—

Notes:

1. The PRC2 bit is set to 0 after setting it to 1 (write enabled) and writing to the SFR area. Change the register protected by the PRC2 bit with the next instruction after that used to set the PRC2 bit to 1. Do not allow interrupts or DTC activation between the instruction to set to the PRC2 bit to 1 and the next instruction.
2. Bits PRC0, PRC1, and PRC3 are not set to 0 even after setting them to 1 (write enabled) and writing to the SFR areas. Set these bits to 0 by a program.

11. Interrupts

11.1 Overview

11.1.1 Types of Interrupts

Figure 11.1 shows the Types of Interrupts.

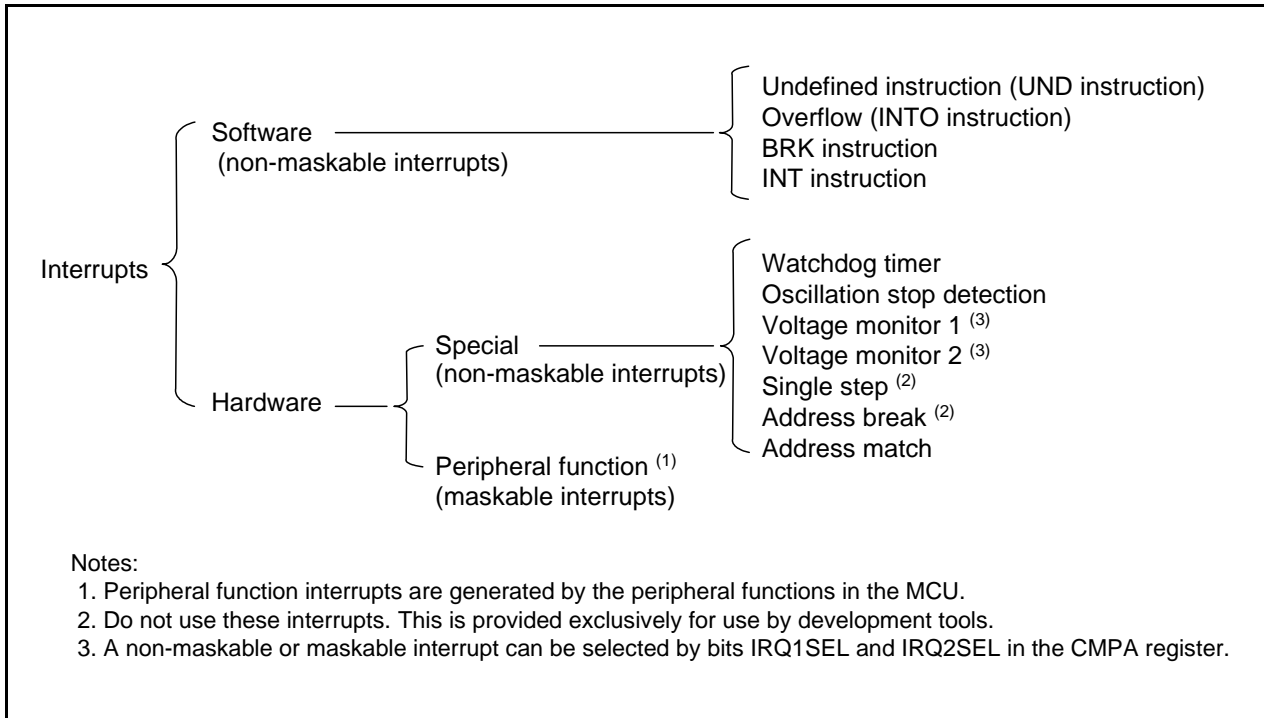

Figure 11.1 Types of Interrupts

- Maskable interrupts: These interrupts are enabled or disabled by the interrupt enable flag (I flag). The interrupt priority **can be changed** based on the interrupt priority level.
- Non-maskable interrupts: These interrupts are not enabled or disabled by the interrupt enable flag (I flag). The interrupt priority **cannot be changed** based on the interrupt priority level.

11.1.2 Software Interrupts

A software interrupt is generated when an instruction is executed. Software interrupts are non-maskable.

11.1.2.1 Undefined Instruction Interrupt

An undefined instruction interrupt is generated when the UND instruction is executed.

11.1.2.2 Overflow Interrupt

An overflow interrupt is generated when the O flag is set to 1 (arithmetic operation overflow) and the INTO instruction is executed. Instructions that set the O flag are as follows:

ABS, ADC, ADCF, ADD, CMP, DIV, DIVU, DIVX, NEG, RMPA, SBB, SHA, and SUB.

11.1.2.3 BRK Interrupt

A BRK interrupt is generated when the BRK instruction is executed.

11.1.2.4 INT Instruction Interrupt

An INT instruction interrupt is generated when the INT instruction is executed. Software interrupt numbers 0 to 63 can be specified with the INT instruction. Because some software interrupt numbers are assigned to peripheral function interrupts, the same interrupt routine as for peripheral function interrupts can be executed by executing the INT instruction.

For software interrupt numbers 0 to 31, the U flag is saved on the stack during instruction execution and the U flag is set to 0 (ISP selected) before the interrupt sequence is executed. The U flag is restored from the stack when returning from the interrupt routine. For software interrupt numbers 32 to 63, the U flag does not change state during instruction execution, and the selected SP is used.

11.1.3 Special Interrupts

Special interrupts are non-maskable.

11.1.3.1 Watchdog Timer Interrupt

A watchdog timer interrupt is generated by the watchdog timer. For details, refer to **14. Watchdog Timer**.

11.1.3.2 Oscillation Stop Detection Interrupt

An oscillation stop detection interrupt is generated by the oscillation stop detection function. For details of the oscillation stop detection function, refer to **9. Clock Generation Circuit**.

11.1.3.3 Voltage Monitor 1 Interrupt

A voltage monitor 1 interrupt is generated by the voltage detection circuit. A non-maskable or maskable interrupt can be selected by IRQ1SEL bit in the CMPA register. For details of the voltage detection circuit, refer to **6. Voltage Detection Circuit**.

11.1.3.4 Voltage Monitor 2 Interrupt

A voltage monitor 2 interrupt is generated by the voltage detection circuit. A non-maskable or maskable interrupt can be selected by IRQ2SEL bit in the CMPA register. For details of the voltage detection circuit, refer to **6. Voltage Detection Circuit**.

11.1.3.5 Single-Step Interrupt, and Address Break Interrupt

Do not use these interrupts. They are provided exclusively for use by development tools.

11.1.3.6 Address Match Interrupt

An address match interrupt is generated immediately before executing an instruction that is stored at an address indicated by registers RMAD0 to RMAD1 if the AIER00 bit in the AIER0 register or the AIER10 bit in the AIER1 register is set to 1 (address match interrupt enabled).

For details of the address match interrupt, refer to **11.6 Address Match Interrupt**.

11.1.4 Peripheral Function Interrupts

A peripheral function interrupt is generated by a peripheral function in the MCU. Peripheral function interrupts are maskable. Refer to **Table 11.2 Relocatable Vector Tables** for sources of the corresponding peripheral function interrupt. For details of peripheral functions, refer to the descriptions of individual peripheral functions.

11.1.5 Interrupts and Interrupt Vectors

There are 4 bytes in each vector. Set the starting address of an interrupt routine in each interrupt vector. When an interrupt request is acknowledged, the CPU branches to the address set in the corresponding interrupt vector. Figure 11.2 shows an Interrupt Vector.



Figure 11.2 Interrupt Vector

11.1.5.1 Fixed Vector Tables

The fixed vector tables are allocated addresses 0FFDCh to 0FFFFh.

Table 11.1 lists the Fixed Vector Tables. The vector addresses (H) of fixed vectors are used by the ID code check function. For details, refer to **28.3 Functions to Prevent Flash Memory from being Rewritten**.

Table 11.1 Fixed Vector Tables

Interrupt Source	Vector Addresses Address (L) to (H)	Remarks	Reference
Undefined instruction	0FFDCh to 0FFDFh	Interrupt with UND instruction	R8C/Tiny Series Software Manual
Overflow	0FFE0h to 0FFE3h	Interrupt with INTO instruction	
BRK instruction	0FFE4h to 0FFE7h	If the content of address 0FFE6h is FFh, program execution starts from the address shown by the vector in the relocatable vector table.	
Address match	0FFE8h to 0FFEBh		11.6 Address Match Interrupt
Single step ⁽¹⁾	0FFEC h to 0FFEFh		
Watchdog timer, Oscillation stop detection, Voltage monitor 1 ⁽²⁾ , Voltage monitor 2 ⁽³⁾	0FFF0h to 0FFF3h		14. Watchdog Timer 9. Clock Generation Circuit 6. Voltage Detection Circuit
Address break ⁽¹⁾	0FFF4h to 0FFF7h		
(Reserved)	0FFF8h to 0FFFBh		
Reset	0FFFCh to 0FFFFh		5. Resets

Notes:

1. Do not use these interrupts. They are provided exclusively for use by development tools.
2. Voltage monitor 1 interrupt is selected when the IRQ1SEL bit in the CMPA register is set to 0 (nonmaskable interrupt).
3. Voltage monitor 2 interrupt is selected when the IRQ2SEL bit in the CMPA register is set to 0 (nonmaskable interrupt).

11.1.5.2 Relocatable Vector Tables

The relocatable vector tables occupy 256 bytes beginning from the starting address set in the INTB register. Table 11.2 lists the Relocatable Vector Tables.

Table 11.2 Relocatable Vector Tables

Interrupt Source	Vector Addresses ⁽¹⁾ Address (L) to Address (H)	Software Interrupt Number	Interrupt Control Register	Reference
BRK instruction ⁽²⁾	+0 to +3 (0000h to 0003h)	0	–	R8C/Tiny Series Software Manual
Flash memory ready	+4 to +7 (0004h to 0007h)	1	FMRDYIC	28. Flash Memory
(Reserved)		2 to 5	–	–
(Reserved)		6	–	–
Timer RC	+28 to +31 (001Ch to 001Fh)	7	TRCIC	19. Timer RC
Timer RD0	+32 to +35 (0020h to 0023h)	8	TRD0IC	20. Timer RD
Timer RD1	+36 to +39 (0024h to 0027h)	9	TRD1IC	
(Reserved)		10	–	–
UART2 transmit/NACK2	+44 to +47 (002Ch to 002Fh)	11	S2TIC	22. Serial Interface (UART2)
UART2 receive/ACK2	+48 to +51 (0030h to 0033h)	12	S2RIC	
Key input	+52 to +55 (0034h to 0037h)	13	KUPIC	11.5 Key Input Interrupt
A/D conversion	+56 to +59 (0038h to 003Bh)	14	ADIC	25. A/D Converter
Synchronous serial communication unit	+60 to +63 (003Ch to 003Fh)	15	SSUIC	23. Synchronous Serial Communication Unit (SSU)
(Reserved)		16	–	–
UART0 transmit	+68 to +71 (0044h to 0047h)	17	S0TIC	21. Serial Interface (UART0)
UART0 receive	+72 to +75 (0048h to 004Bh)	18	S0RIC	
(Reserved)		19	–	
(Reserved)		20	–	
(Reserved)		21	–	
Timer RA	+88 to +91 (0058h to 005Bh)	22	TRAIC	17. Timer RA
(Reserved)		23	–	–
Timer RB	+96 to +99 (0060h to 0063h)	24	TRBIC	18. Timer RB
$\overline{\text{INT}}1$	+100 to +103 (0064h to 0067h)	25	INT1IC	11.4 $\overline{\text{INT}}$ Interrupt
$\overline{\text{INT}}3$	+104 to +107 (0068h to 006Bh)	26	INT3IC	
(Reserved)		27	–	–
(Reserved)		28	–	–
$\overline{\text{INT}}0$	+116 to +119 (0074h to 0077h)	29	INT0IC	11.4 $\overline{\text{INT}}$ Interrupt
UART2 bus collision detection	+120 to +123 (0078h to 007Bh)	30	U2BCNIC	22. Serial Interface (UART2)
(Reserved)		31	–	–
Software ⁽²⁾	+128 to +131 (0080h to 0083h) to +164 to +167 (00A4h to 00A7h)	32 to 41	–	R8C/Tiny Series Software Manual
(Reserved)		42 to 49	–	–
Voltage monitor 1 ⁽³⁾	+200 to +203 (00C8h to 00CBh)	50	VCMP1IC	6. Voltage Detection Circuit
Voltage monitor 2 ⁽⁴⁾	+204 to +207 (00CCh to 00CFh)	51	VCMP2IC	
(Reserved)		52 to 55	–	–
Software ⁽²⁾	+224 to +227 (00E0h to 00E3h) to +252 to +255 (00FCh to 00FFh)	56 to 63	–	R8C/Tiny Series Software Manual

Notes:

1. These addresses are relative to those in the INTB register.
2. These interrupts are not disabled by the I flag.
3. Voltage monitor 1 interrupt is selected when the IRQ1SEL bit in the CMPA register is set to 1 (maskable interrupt).
4. Voltage monitor 2 interrupt is selected when the IRQ2SEL bit in the CMPA register is set to 1 (maskable interrupt).

11.2 Registers

11.2.1 Interrupt Control Register (S2TIC, S2RIC, KUPIC, ADIC, S0TIC, S0RIC, TRAIC, TRBIC, U2BCNIC, VCMP1IC, VCMP2IC)

Address 004Bh (S2TIC), 004Ch (S2RIC), 004Dh (KUPIC), 004Eh (ADIC), 0051h (S0TIC), 0052h (S0RIC), 0056h (TRAIC), 0058h (TRBIC), 005Eh (U2BCNIC), 0072h (VCMP1IC), 0073h (VCMP2IC)

Bit	b7	b6	b5	b4	b3	b2	b1	b0
Symbol	—	—	—	—	IR	ILVL2	ILVL1	ILVL0
After Reset	X	X	X	X	X	0	0	0

Bit	Symbol	Bit Name	Function	R/W
b0	ILVL0	Interrupt priority level select bit	^{b2 b1 b0} 0 0 0: Level 0 (interrupt disabled) 0 0 1: Level 1 0 1 0: Level 2 0 1 1: Level 3 1 0 0: Level 4 1 0 1: Level 5 1 1 0: Level 6 1 1 1: Level 7	R/W
b1	ILVL1			R/W
b2	ILVL2			R/W
b3	IR	Interrupt request bit	0: No interrupt requested 1: Interrupt requested	R/W (1)
b4	—	Nothing is assigned. If necessary, set to 0. When read, the content is undefined.		—
b5	—			
b6	—			
b7	—			

Note:

- Only 0 can be written to the IR bit. Do not write 1 to this bit.

Rewrite the interrupt control register when an interrupt request corresponding to the register is not generated. Refer to **11.8.5 Rewriting Interrupt Control Register**.

11.2.2 Interrupt Control Register (FMRDYIC, TRCIC, TRD0IC, TRD1IC, SSUIC)

Address 0041h (FMRDYIC), 0047h (TRCIC), 0048h (TRD0IC), 0049h (TRD1IC), 004Fh (SSUIC)

Bit	b7	b6	b5	b4	b3	b2	b1	b0
Symbol	—	—	—	—	IR	ILVL2	ILVL1	ILVL0
After Reset	X	X	X	X	X	0	0	0

Bit	Symbol	Bit Name	Function	R/W
b0	ILVL0	Interrupt priority level select bit	b2 b1 b0 0 0 0: Level 0 (interrupt disabled) 0 0 1: Level 1 0 1 0: Level 2 0 1 1: Level 3 1 0 0: Level 4 1 0 1: Level 5 1 1 0: Level 6 1 1 1: Level 7	R/W
b1	ILVL1			R/W
b2	ILVL2			R/W
b3	IR			Interrupt request bit
b4	—	Nothing is assigned. If necessary, set to 0.		—
b5	—	When read, the content is undefined.		—
b6	—			—
b7	—			—

Rewrite the interrupt control register when an interrupt request corresponding to the register is not generated. Refer to **11.8.5 Rewriting Interrupt Control Register**.

11.2.3 INT_i Interrupt Control Register (INT_iIC) (i = 0 to 1, 3)

Address 005Ah (INT3IC), 005Dh (INT0IC)

Bit	b7	b6	b5	b4	b3	b2	b1	b0
Symbol	—	—	—	POL	IR	ILVL2	ILVL1	ILVL0
After Reset	X	X	0	0	X	0	0	0

Bit	Symbol	Bit Name	Function	R/W
b0	ILVL0	Interrupt priority level select bit	b2 b1 b0 0 0 0: Level 0 (interrupt disabled) 0 0 1: Level 1 0 1 0: Level 2 0 1 1: Level 3 1 0 0: Level 4 1 0 1: Level 5 1 1 0: Level 6 1 1 1: Level 7	R/W
b1	ILVL1			R/W
b2	ILVL2			R/W
b3	IR	Interrupt request bit	0: No interrupt requested 1: Interrupt requested	R/W (1)
b4	POL	Polarity switch bit ⁽³⁾	0: Falling edge selected 1: Rising edge selected ⁽²⁾	R/W
b5	—	Reserved bit	Set to 0.	R/W
b6	—	Nothing is assigned. If necessary, set to 0.		—
b7	—	When read, the content is undefined.		—

Notes:

1. Only 0 can be written to the IR bit. (Do not write 1 to this bit.)
2. If the INT_iPL bit in the INTEN register is set to 1 (both edges), set the POL bit to 0 (falling edge selected).
3. The IR bit may be set to 1 (interrupt requested) when the POL bit is rewritten. Refer to **11.8.4 Changing Interrupt Sources**.

Rewrite the interrupt control register when an interrupt request corresponding to the register is not generated. Refer to **11.8.5 Rewriting Interrupt Control Register**.

11.3 Interrupt Control

The following describes enabling and disabling maskable interrupts and setting the acknowledgement priority. This description does not apply to non-maskable interrupts.

Use the I flag in the FLG register, IPL, and bits ILVL2 to ILVL0 in the corresponding interrupt control register to enable or disable a maskable interrupt. Whether an interrupt is requested or not is indicated by the IR bit in the corresponding interrupt control register.

11.3.1 I Flag

The I flag enables or disables maskable interrupts. Setting the I flag to 1 (enabled) enables maskable interrupts. Setting the I flag to 0 (disabled) disables all maskable interrupts.

11.3.2 IR Bit

The IR bit is set to 1 (interrupt requested) when an interrupt request is generated. After the interrupt request is acknowledged and the CPU branches to the corresponding interrupt vector, the IR bit is set to 0 (no interrupt requested).

The IR bit can be set to 0 by a program. Do not write 1 to this bit.

However, the IR bit operations of the timer RC interrupt, the timer RD interrupt, the synchronous serial communication unit interrupt and the flash memory interrupt are different. Refer to **11.7 Timer RC Interrupt, Timer RD Interrupt, Synchronous Serial Communication Unit Interrupt, and Flash Memory Interrupt (Interrupts with Multiple Interrupt Request Sources)**.

11.3.3 Bits ILVL2 to ILVL0, IPL

Interrupt priority levels can be set using bits ILVL2 to ILVL0.

Table 11.3 lists the Settings of Interrupt Priority Levels and Table 11.4 lists the Interrupt Priority Levels Enabled by IPL.

The following are the conditions when an interrupt is acknowledged:

- I flag = 1
- IR bit = 1
- Interrupt priority level > IPL

The I flag, IR bit, bits ILVL2 to ILVL0, and IPL are independent of each other. They do not affect one another.

Table 11.3 Settings of Interrupt Priority Levels

Bits ILVL2 to ILVL0	Interrupt Priority Level	Priority
000b	Level 0 (interrupt disabled)	–
001b	Level 1	Low  High
010b	Level 2	
011b	Level 3	
100b	Level 4	
101b	Level 5	
110b	Level 6	
111b	Level 7	

Table 11.4 Interrupt Priority Levels Enabled by IPL

IPL	Enabled Interrupt Priority Level
000b	Interrupt level 1 and above
001b	Interrupt level 2 and above
010b	Interrupt level 3 and above
011b	Interrupt level 4 and above
100b	Interrupt level 5 and above
101b	Interrupt level 6 and above
110b	Interrupt level 7 and above
111b	All maskable interrupts are disabled

11.3.4 Interrupt Sequence

The following describes an interrupt sequence which is performed from when an interrupt request is acknowledged until the interrupt routine is executed.

When an interrupt request is generated while an instruction is being executed, the CPU determines its interrupt priority level after the instruction is completed. The CPU starts the interrupt sequence from the following cycle. However, for the SMOVB, SMOVF, SSTR, or RMPA instruction, if an interrupt request is generated while the instruction is being executed, the MCU suspends the instruction to start the interrupt sequence. The interrupt sequence is performed as indicated below.

Figure 11.3 shows the Time Required for Executing Interrupt Sequence.

- (1) The CPU obtains interrupt information (interrupt number and interrupt request level) by reading address 00000h. The IR bit for the corresponding interrupt is set to 0 (no interrupt requested). ⁽²⁾
- (2) The FLG register is saved to a temporary register ⁽¹⁾ in the CPU immediately before entering the interrupt sequence.
- (3) The I, D and U flags in the FLG register are set as follows:
 The I flag is set to 0 (interrupts disabled).
 The D flag is set to 0 (single-step interrupt disabled).
 The U flag is set to 0 (ISP selected).
 However, the U flag does not change state if an INT instruction for software interrupt number 32 to 63 is executed.
- (4) The CPU internal temporary register ⁽¹⁾ is saved on the stack.
- (5) The PC is saved on the stack.
- (6) The interrupt priority level of the acknowledged interrupt is set in the IPL.
- (7) The starting address of the interrupt routine set in the interrupt vector is stored in the PC.

After the interrupt sequence is completed, instructions are executed from the starting address of the interrupt routine.

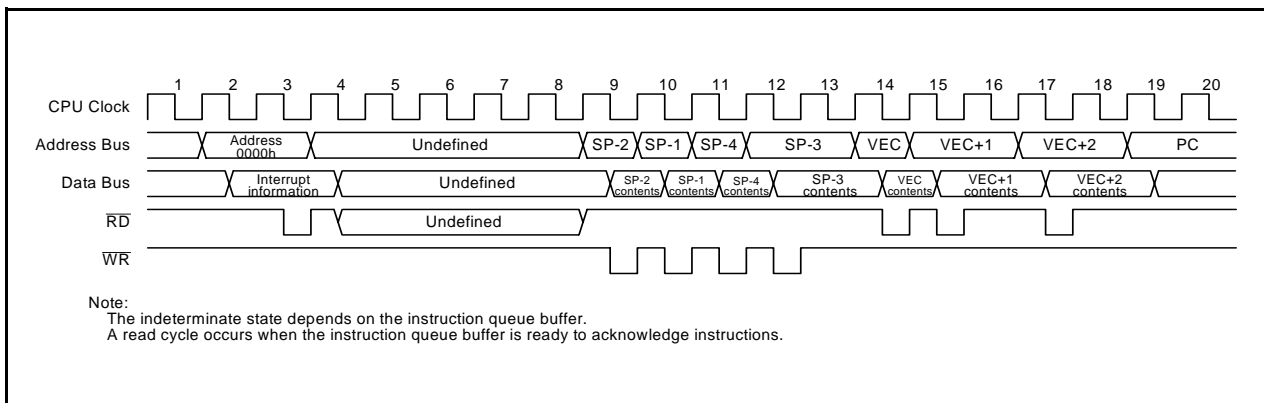

Figure 11.3 Time Required for Executing Interrupt Sequence

Notes:

1. These registers cannot be accessed by the user.
2. Refer to **11.7 Timer RC Interrupt, Timer RD Interrupt, Synchronous Serial Communication Unit Interrupt, and Flash Memory Interrupt (Interrupts with Multiple Interrupt Request Sources)** for the IR bit operations of the timer RC Interrupt, timer RD Interrupt, and Synchronous Serial Communication unit Interrupt.

11.3.5 Interrupt Response Time

Figure 11.4 shows the Interrupt Response Time. The interrupt response time is the period from when an interrupt request is generated until the first instruction in the interrupt routine is executed. The interrupt response time includes the period from when an interrupt request is generated until the currently executing instruction is completed (refer to (a) in Figure 11.4) and the period required for executing the interrupt sequence (20 cycles, refer to (b) in Figure 11.4).

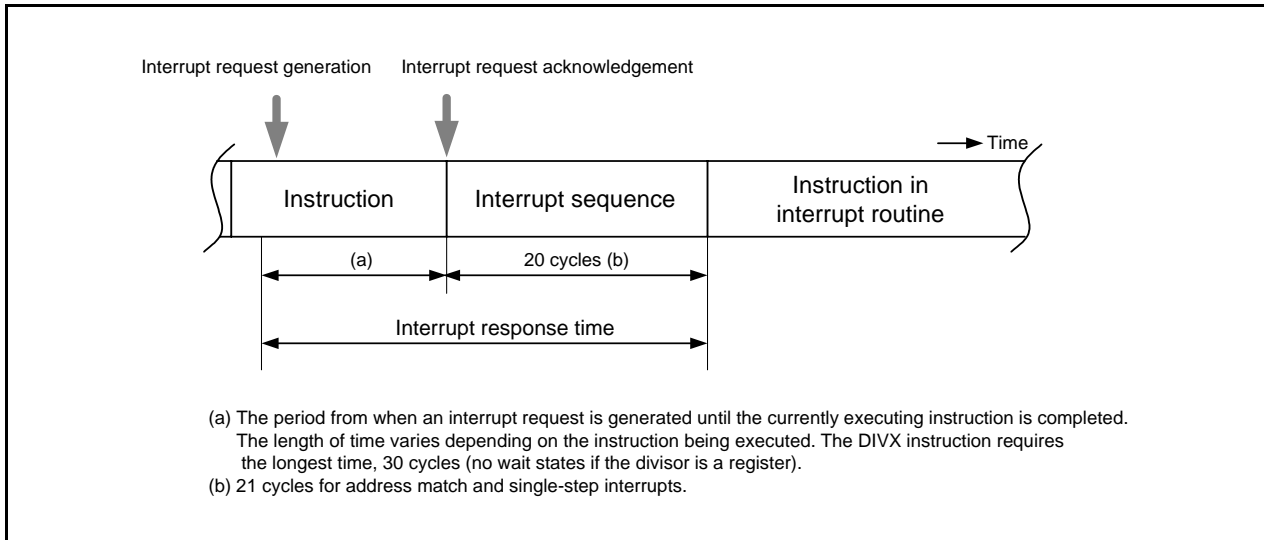

Figure 11.4 Interrupt Response Time

11.3.6 IPL Change when Interrupt Request is Acknowledged

When a maskable interrupt request is acknowledged, the interrupt priority level of the acknowledged interrupt is set in the IPL.

When a software interrupt or special interrupt request is acknowledged, the level listed in Table 11.5 is set in the IPL.

Table 11.5 lists the IPL Value When Software or Special Interrupt is Acknowledged.

Table 11.5 IPL Value When Software or Special Interrupt is Acknowledged

Interrupt Source without Interrupt Priority Level	Value Set in IPL
Watchdog timer, oscillation stop detection, voltage monitor 1, voltage monitor 2, address break	7
Software, address match, single-step	Not changed

11.3.7 Saving Registers

In the interrupt sequence, the FLG register and PC are saved on the stack.

After an extended 16 bits, 4 high-order bits in the PC and 4 high-order (IPL) and 8 low-order bits in the FLG register, are saved on the stack, the 16 low-order bits in the PC are saved.

Figure 11.5 shows the Stack State Before and After Acknowledgement of Interrupt Request.

The other necessary registers should be saved by a program at the beginning of the interrupt routine. The PUSHM instruction can save several registers in the register bank being currently used ⁽¹⁾ with a single instruction.

Note:

1. Selectable from registers R0, R1, R2, R3, A0, A1, SB, and FB.

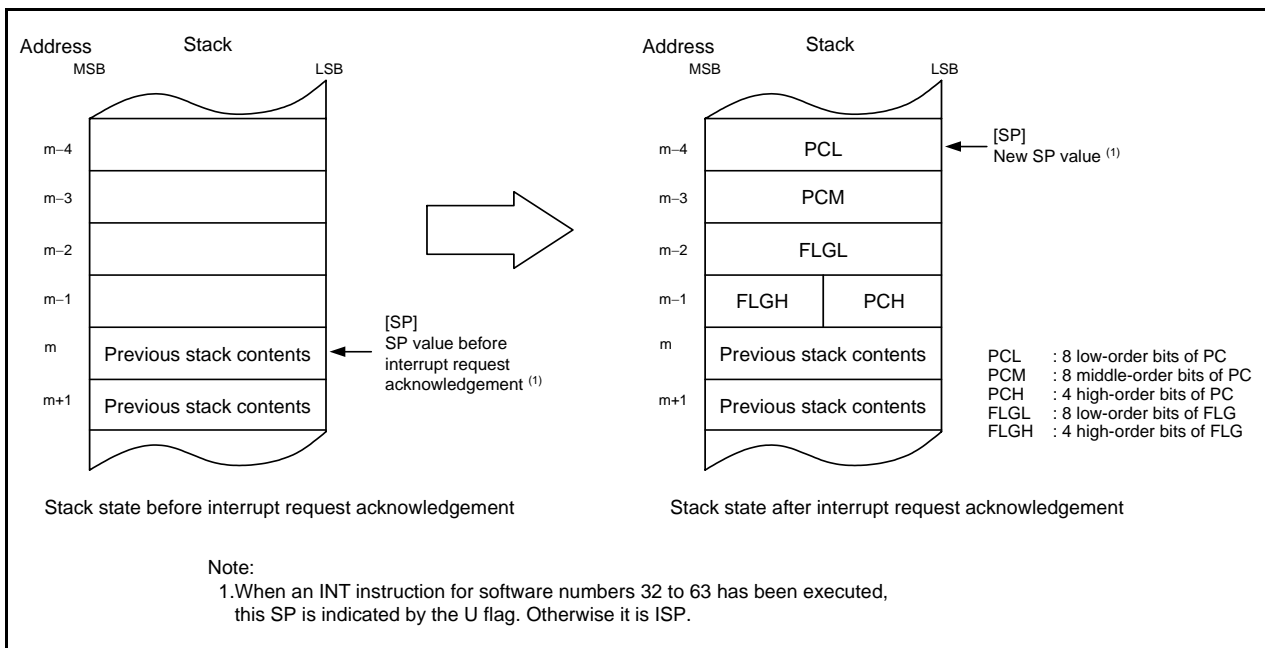

Figure 11.5 Stack State Before and After Acknowledgement of Interrupt Request

The register saving operation, which is performed as part of the interrupt sequence, saved in 8 bits at a time in four steps.

Figure 11.6 shows the Register Saving Operation.

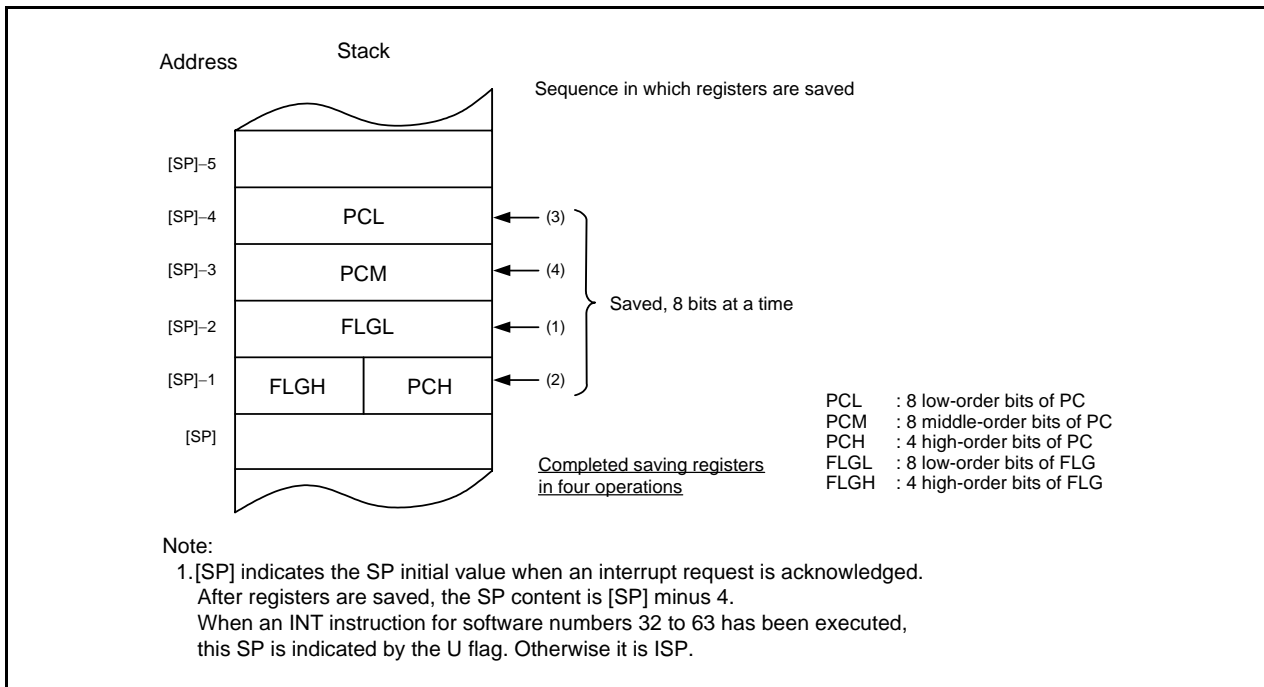

Figure 11.6 Register Saving Operation

11.3.8 Returning from Interrupt Routine

When the REIT instruction is executed at the end of an interrupt routine, the FLG register and PC, which have been saved on the stack, are automatically restored. The program, that was running before the interrupt request was acknowledged, starts running again.

Registers saved by a program in an interrupt routine should be saved using the POPM instruction or a similar instruction before executing the REIT instruction.

11.3.9 Interrupt Priority

If two or more interrupt requests are generated while a single instruction is being executed, the interrupt with the higher priority is acknowledged.

Set bits ILVL2 to ILVL0 to select any priority level for maskable interrupts (peripheral function). However, if two or more maskable interrupts have the same priority level, their interrupt priority is resolved by hardware, with the higher priority interrupts acknowledged.

The priority of watchdog timer and other special interrupts is set by hardware.

Figure 11.7 shows the Hardware Interrupt Priority.

Software interrupts are not affected by the interrupt priority. If an instruction is executed, the MCU executes the interrupt routine.

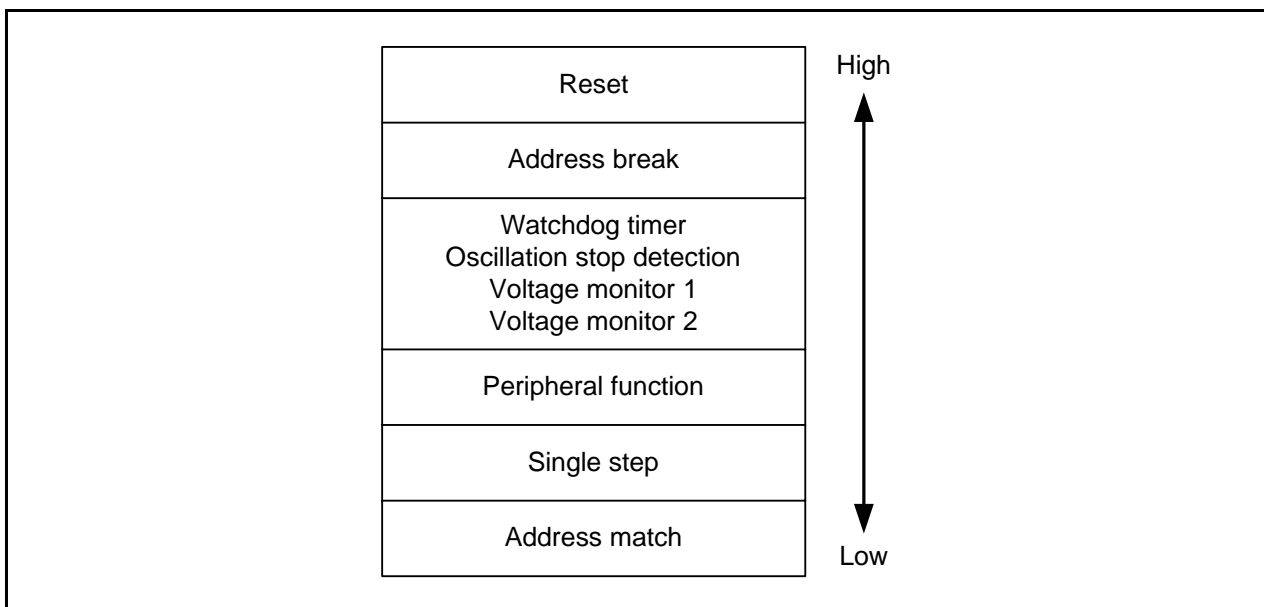

Figure 11.7 Hardware Interrupt Priority

11.3.10 Interrupt Priority Level Selection Circuit

The interrupt priority level selection circuit is used to select the highest priority interrupt. Figure 11.8 shows the Interrupt Priority Level Selection Circuit.

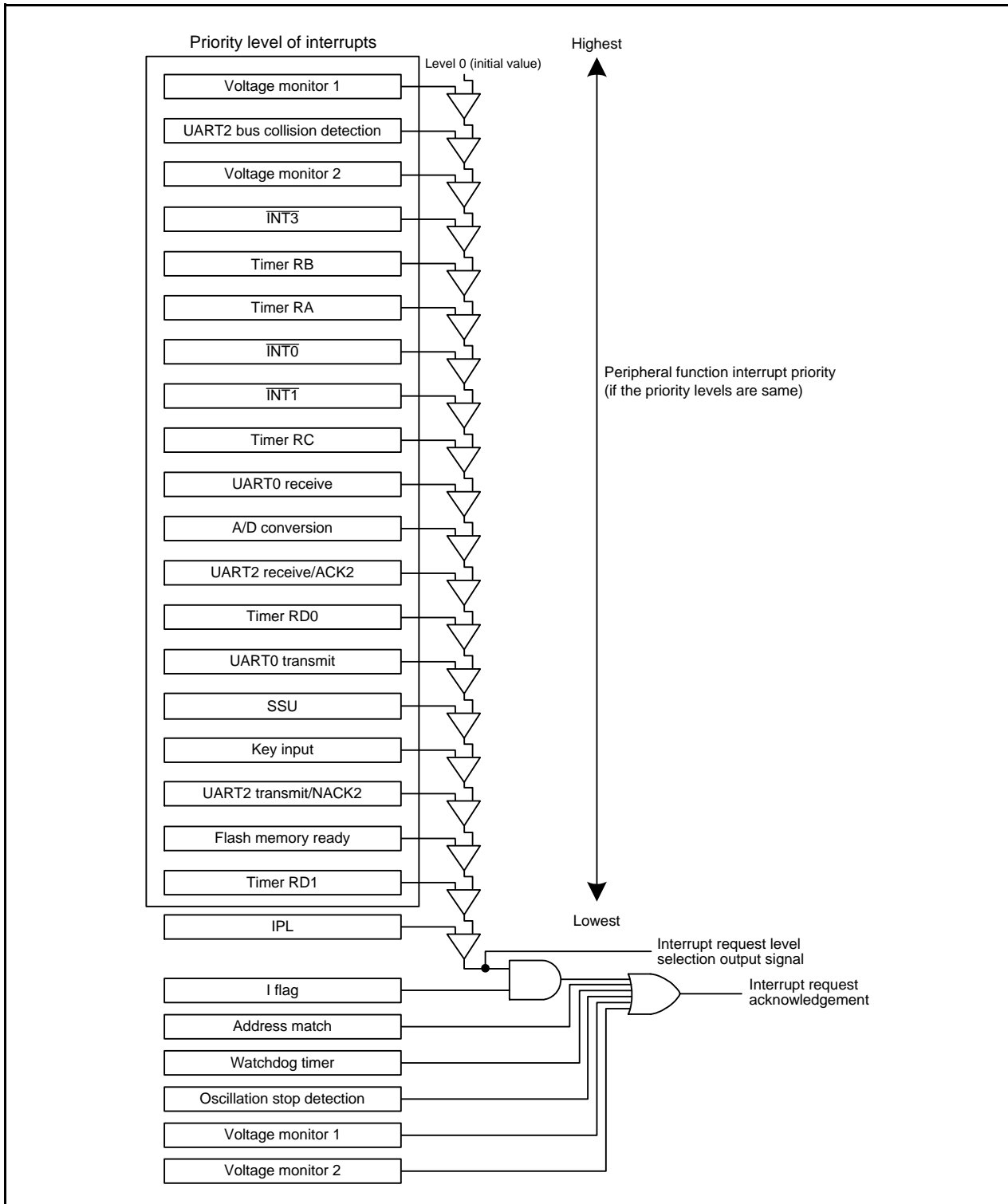

Figure 11.8 Interrupt Priority Level Selection Circuit

11.4 $\overline{\text{INT}}$ Interrupt

11.4.1 $\overline{\text{INT}}_i$ Interrupt ($i = 0$ to $1, 3$)

The $\overline{\text{INT}}_i$ interrupt is generated by an $\overline{\text{INT}}_i$ input. To use the $\overline{\text{INT}}_i$ interrupt, set the INT_iEN bit in the INTEN register is to 1 (enabled). The edge polarity is selected using the INT_iPL bit in the INTEN register and the POL bit in the INT_iIC register. The input pins used as the $\overline{\text{INT}}_i$ input can be selected.

Also, inputs can be passed through a digital filter with three different sampling clocks.

The $\overline{\text{INT}}_0$ pin is shared with the pulse output forced cutoff input of timer RC, and the external trigger input of timer RB.

Table 11.6 lists the Pin Configuration of $\overline{\text{INT}}$ Interrupt.

Table 11.6 Pin Configuration of $\overline{\text{INT}}$ Interrupt

Pin Name	Assigned Pin	I/O	Function
$\overline{\text{INT}}_0$	P4_5	Input	$\overline{\text{INT}}_0$ interrupt input, timer RB external trigger input, timer RC pulse output forced cutoff input
$\overline{\text{INT}}_1$	P1_5, P1_7, or P3_6	Input	$\overline{\text{INT}}_1$ interrupt input
$\overline{\text{INT}}_3$	P3_3	Input	$\overline{\text{INT}}_3$ interrupt input

11.4.2 $\overline{\text{INT}}$ Interrupt Input Pin Select Register (INTSR)

Address 018Eh

Bit	b7	b6	b5	b4	b3	b2	b1	b0
Symbol	—	—	—	—	—	INT1SEL1	INT1SELO	—
After Reset	0	0	0	0	0	0	0	0

Bit	Symbol	Bit Name	Function	R/W
b0	—	Nothing is assigned. If necessary, set to 0. When read, the content is 0.		—
b1	INT1SELO	$\overline{\text{INT}}_1$ pin select bit	^{b2 b1} 0 0: P1_7 assigned 0 1: P1_5 assigned 1 1: P3_6 assigned Other than above: Do not set.	R/W
b2	INT1SEL1			R/W
b3	—	Reserved bit	Set to 0.	R/W
b4	—			R/W
b5	—			R/W
b6	—			R/W
b7	—			R/W

The INTSR register selects which pin is assigned to the $\overline{\text{INT}}_1$ input. To use $\overline{\text{INT}}_1$, set this register.

Set the INTSR register before setting the $\overline{\text{INT}}_1$ associated registers. Also, do not change the setting values in this register during $\overline{\text{INT}}_1$ operation.

11.4.3 External Input Enable Register 0 (INTEN)

Address 01FAh

Bit	b7	b6	b5	b4	b3	b2	b1	b0
Symbol	INT3PL	INT3EN	—	—	INT1PL	INT1EN	INT0PL	INT0EN
After Reset	0	0	0	0	0	0	0	0

Bit	Symbol	Bit Name	Function	R/W
b0	INT0EN	$\overline{\text{INT0}}$ input enable bit	0: Disabled 1: Enabled	R/W
b1	INT0PL	$\overline{\text{INT0}}$ input polarity select bit (1, 2)	0: One edge 1: Both edges	R/W
b2	INT1EN	$\overline{\text{INT1}}$ input enable bit	0: Disabled 1: Enabled	R/W
b3	INT1PL	$\overline{\text{INT1}}$ input polarity select bit (1, 2)	0: One edge 1: Both edges	R/W
b4	—	Reserved bits	Set to 0.	R/W
b5	—			
b6	INT3EN	$\overline{\text{INT3}}$ input enable bit	0: Disabled 1: Enabled	R/W
b7	INT3PL	$\overline{\text{INT3}}$ input polarity select bit (1, 2)	0: One edge 1: Both edges	R/W

Notes:

1. To set the INTiPL bit (i = 0 to 1, 3) to 1 (both edges), set the POL bit in the INTiIC register to 0 (falling edge selected).
2. The IR bit in the INTiIC register may be set to 1 (interrupt requested) if the INTEN register is rewritten. Refer to **11.8.4 Changing Interrupt Sources**.

11.4.4 INT Input Filter Select Register 0 (INTF)

Address 01FCh

Bit	b7	b6	b5	b4	b3	b2	b1	b0
Symbol	INT3F1	INT3F0	—	—	INT1F1	INT1F0	INT0F1	INT0F0
After Reset	0	0	0	0	0	0	0	0

Bit	Symbol	Bit Name	Function	R/W
b0	INT0F0	INT0 input filter select bit	^{b1 b0} 0 0: No filter 0 1: Filter with f1 sampling 1 0: Filter with f8 sampling 1 1: Filter with f32 sampling	R/W
b1	INT0F1			R/W
b2	INT1F0	INT1 input filter select bit	^{b3 b2} 0 0: No filter 0 1: Filter with f1 sampling 1 0: Filter with f8 sampling 1 1: Filter with f32 sampling	R/W
b3	INT1F1			R/W
b4	—	Reserved bits	Set to 0.	R/W
b5	—			R/W
b6	INT3F0	INT3 input filter select bit	^{b7 b6} 0 0: No filter 0 1: Filter with f1 sampling 1 0: Filter with f8 sampling 1 1: Filter with f32 sampling	R/W
b7	INT3F1			R/W

11.4.5 $\overline{\text{INT}}_i$ Input Filter (i = 0 to 1, 3)

The $\overline{\text{INT}}_i$ input contains a digital filter. The sampling clock is selected using bits INTiF1 and INTiF0 in INTF register. The $\overline{\text{INT}}_i$ level is sampled every sampling clock cycle and if the sampled input level matches three times, the IR bit in the INTiIC register is set to 1 (interrupt requested).

Figure 11.9 shows the $\overline{\text{INT}}_i$ Input Filter Configuration. Figure 11.10 shows an Operating Example of $\overline{\text{INT}}_i$ Input Filter.

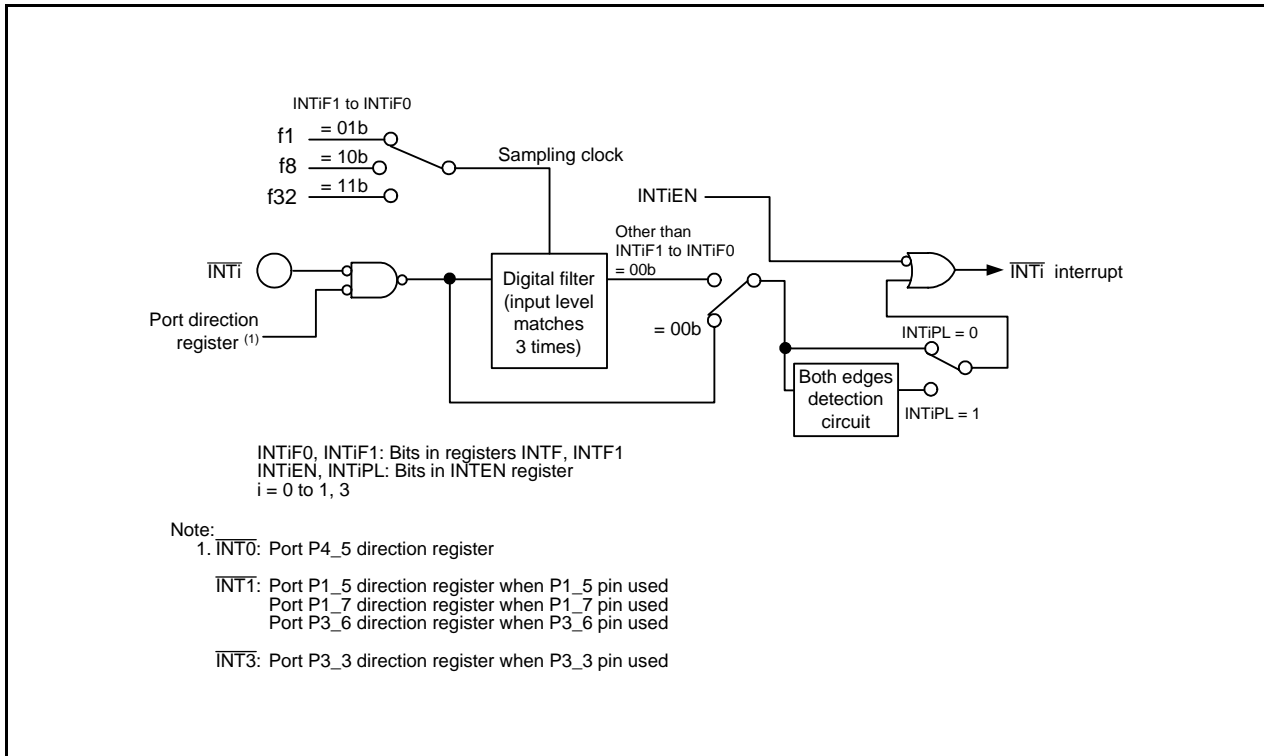

Figure 11.9 $\overline{\text{INT}}_i$ Input Filter Configuration

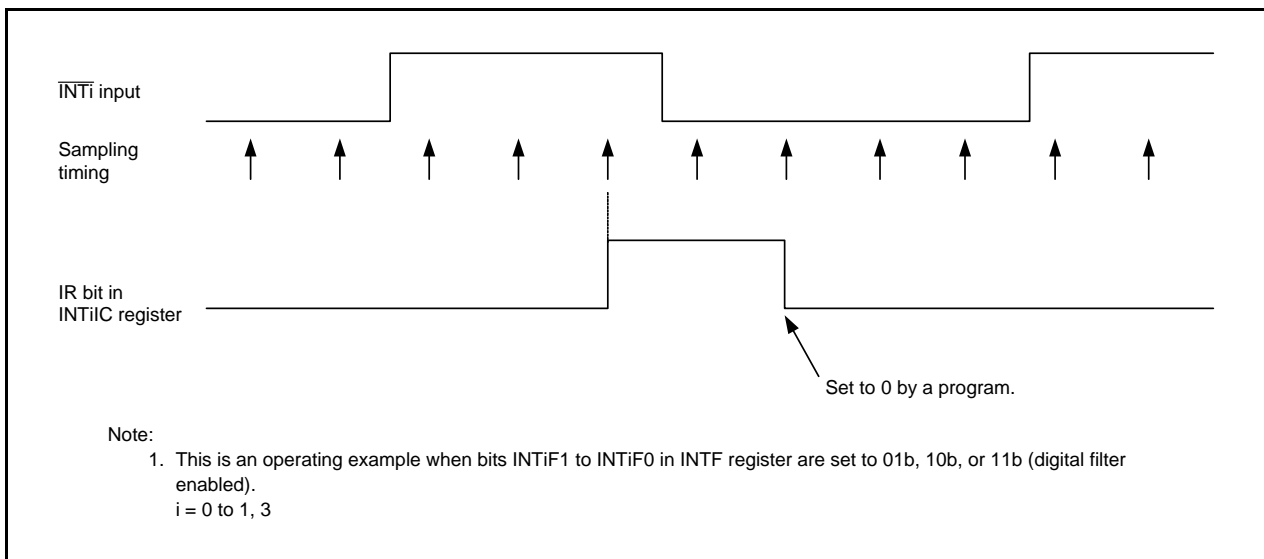

Figure 11.10 Operating Example of $\overline{\text{INT}}_i$ Input Filter

11.5 Key Input Interrupt

A key input interrupt request is generated by one of the input edges of pins $\overline{KI0}$ to $\overline{KI3}$. The key input interrupt can be used as a key-on wake-up function to exit wait or stop mode.

The $KIiEN$ ($i = 0$ to 3) bit in the $KIEN$ register is used to select whether or not the pins are used as the \overline{KIi} input. The $KIiPL$ bit in the $KIEN$ register is also used to select the input polarity.

When inputting “L” to the \overline{KIi} pin, which sets the $KIiPL$ bit to 0 (falling edge), the input to the other pins $\overline{KI0}$ to $\overline{KI3}$ is not detected as interrupts. When inputting “H” to the \overline{KIi} pin, which sets the $KIiPL$ bit to 1 (rising edge), the input to the other pins $\overline{KI0}$ to $\overline{KI3}$ is not also detected as interrupts.

Figure 11.11 shows a Block Diagram of Key Input Interrupt. Table 11.7 lists the Pin Configuration of Key Input Interrupt.

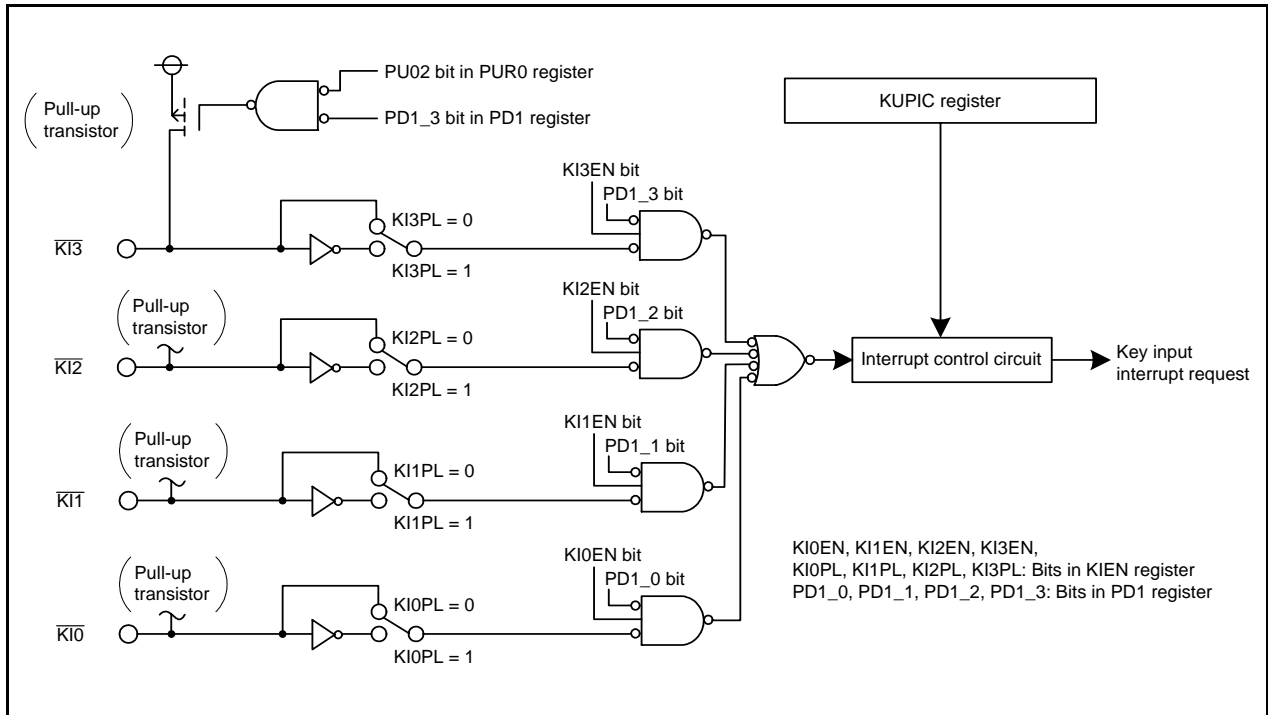

Figure 11.11 Block Diagram of Key Input Interrupt

Table 11.7 Pin Configuration of Key Input Interrupt

Pin Name	I/O	Function
$\overline{KI0}$	Input	$\overline{KI0}$ interrupt input
$\overline{KI1}$	Input	$\overline{KI1}$ interrupt input
$\overline{KI2}$	Input	$\overline{KI2}$ interrupt input
$\overline{KI3}$	Input	$\overline{KI3}$ interrupt input

11.5.1 Key Input Enable Register 0 (KIEN)

Address 01FEh

Bit	b7	b6	b5	b4	b3	b2	b1	b0
Symbol	KI3PL	KI3EN	KI2PL	KI2EN	KI1PL	KI1EN	KI0PL	KI0EN
After Reset	0	0	0	0	0	0	0	0

Bit	Symbol	Bit Name	Function	R/W
b0	KI0EN	KI0 input enable bit	0: Disabled 1: Enabled	R/W
b1	KI0PL	KI0 input polarity select bit	0: Falling edge 1: Rising edge	R/W
b2	KI1EN	KI1 input enable bit	0: Disabled 1: Enabled	R/W
b3	KI1PL	KI1 input polarity select bit	0: Falling edge 1: Rising edge	R/W
b4	KI2EN	KI2 input enable bit	0: Disabled 1: Enabled	R/W
b5	KI2PL	KI2 input polarity select bit	0: Falling edge 1: Rising edge	R/W
b6	KI3EN	KI3 input enable bit	0: Disabled 1: Enabled	R/W
b7	KI3PL	KI3 input polarity select bit	0: Falling edge 1: Rising edge	R/W

The IR bit in the KUPIC register may be set to 1 (interrupt requested) when the KIEN register is rewritten. Refer to **11.8.4 Changing Interrupt Sources**.

11.6 Address Match Interrupt

An address match interrupt request is generated immediately before execution of the instruction at the address indicated by the RMADi register (i = 0 or 1). This interrupt is used as a break function by the debugger. When the on-chip debugger is used, do not set an address match interrupt (registers AIER0, AIER1, RMAD0, and RMAD1, and fixed vector tables) in the user system.

Set the starting address of any instruction in the RMADi register (i = 0 or 1). The AIERi0 bit in the AIERi register can be used to select enable or disable the interrupt. The address match interrupt is not affected by the I flag and IPL.

The PC value (refer to **11.3.7 Saving Registers**) which is saved on the stack when an address match interrupt request is acknowledged varies depending on the instruction at the address indicated by the RMADi register. (The appropriate return address is not saved on the stack.) When returning from the address match interrupt, follow one of the following means:

- Rewrite the contents of the stack and use the REIT instruction to return.
- Use an instruction such as POP to restore the stack to its previous state before the interrupt request was acknowledged. Then use a jump instruction to return.

Table 11.8 lists the PC Value Saved on Stack When Address Match Interrupt Request is Acknowledged.

Table 11.8 PC Value Saved on Stack When Address Match Interrupt Request is Acknowledged

Address Indicated by RMADi Register (i = 0 or 1)	PC Value Saved ⁽¹⁾
<ul style="list-style-type: none"> • Instruction with 2-byte operation code ⁽²⁾ • Instruction with 1-byte operation code ⁽²⁾ ADD.B:S #IMM8,dest SUB.B:S #IMM8,dest AND.B:S #IMM8,dest OR.B:S #IMM8,dest MOV.B:S #IMM8,dest STZ #IMM8,dest STNZ #IMM8,dest STZX #IMM81,#IMM82,dest CMP.B:S #IMM8,dest PUSHM src POPM dest JMPS #IMM8 JSRS #IMM8 MOV.B:S #IMM,dest (however, dest = A0 or A1)	Address indicated by RMADi register + 2
Instructions other than above	Address indicated by RMADi register + 1

Notes:

1. Refer to **11.3.7 Saving Registers**.
2. Operation code: Refer to the **R8C/Tiny Series Software Manual (REJ09B0001)**.

Chapter 4. Instruction Code/Number of Cycles contains diagrams showing operation code below each syntax. Operation code is shown in the bold frame in the diagrams.

Table 11.9 Correspondence Between Address Match Interrupt Sources and Associated Registers

Address Match Interrupt Source	Address Match Interrupt Enable Bit	Address Match Interrupt Register
Address match interrupt 0	AIER00	RMAD0
Address match interrupt 1	AIER10	RMAD1

11.6.1 Address Match Interrupt Enable Register i (AIERi) (i = 0 or 1)

Address 01C3h (AIER0), 01C7h (AIER1)

Bit	b7	b6	b5	b4	b3	b2	b1	b0	
Symbol	—	—	—	—	—	—	—	AIER00	AIER0 register
After Reset	0	0	0	0	0	0	0	0	

Symbol	—	—	—	—	—	—	—	AIER10	AIER1 register
After Reset	0	0	0	0	0	0	0	0	

Bit	Symbol	Bit Name	Function	R/W
b0	AIERi0	Address match interrupt i enable bit	0: Disabled 1: Enabled	R/W
b1	—	Nothing is assigned. If necessary, set to 0. When read, the content is 0.		—
b2	—			
b3	—			
b4	—			
b5	—			
b6	—			
b7	—			

11.6.2 Address Match Interrupt Register i (RMADi) (i = 0 or 1)

Address 01C2h to 01C0h (RMAD0), 01C6h to 01C4h (RMAD1)

Bit	b7	b6	b5	b4	b3	b2	b1	b0
Symbol	—	—	—	—	—	—	—	—
After Reset	X	X	X	X	X	X	X	X

Bit	b15	b14	b13	b12	b11	b10	b9	b8
Symbol	—	—	—	—	—	—	—	—
After Reset	X	X	X	X	X	X	X	X

Bit	b23	b22	b21	b20	b19	b18	b17	b16
Symbol	—	—	—	—	—	—	—	—
After Reset	0	0	0	0	X	X	X	X

Bit	Symbol	Function	Setting Range	R/W
b19 to b0	—	Address setting register for address match interrupt	00000h to FFFFFh	R/W
b20	—	Nothing is assigned. If necessary, set to 0. When read, the content is 0.		—
b21	—			
b22	—			
b23	—			

11.7 Timer RC Interrupt, Timer RD Interrupt, Synchronous Serial Communication Unit Interrupt, and Flash Memory Interrupt (Interrupts with Multiple Interrupt Request Sources)

The timer RC interrupt, timer RD (timer RD0) interrupt, timer RD (timer RD1) interrupt, synchronous serial communication unit interrupt, and flash memory interrupt each have multiple interrupt request sources. An interrupt request is generated by the logical OR of several interrupt request sources and is reflected in the IR bit in the corresponding interrupt control register. Therefore, each of these peripheral functions has its own interrupt request source status register (status register) and interrupt request source enable register (enable register) to control the generation of interrupt requests (change of the IR bit in the interrupt control register). Table 11.10 lists the Registers Associated with Timer RC Interrupt, Timer RD Interrupt, Synchronous Serial Communication Unit Interrupt, and Flash Memory Interrupt and Figure 11.12 shows a Block Diagram of Timer RD Interrupt.

Table 11.10 Registers Associated with Timer RC Interrupt, Timer RD Interrupt, Synchronous Serial Communication Unit Interrupt, and Flash Memory Interrupt

Peripheral Function Name	Status Register of Interrupt Request Source	Enable Register of Interrupt Request Source	Interrupt Control Register
Timer RC	TRCSR	TRCIER	TRCIC
Timer RD	Timer RD0	TRDSR0	TRD0IC
	Timer RD1	TRDSR1	TRD1IC
Synchronous serial communication unit	SSSR	SSER	SSUIC
Flash memory	RDYSTI	RDYSTIE	FMRDYIC
	BSYAEI	BSYAEIE	
		CMDERIE	

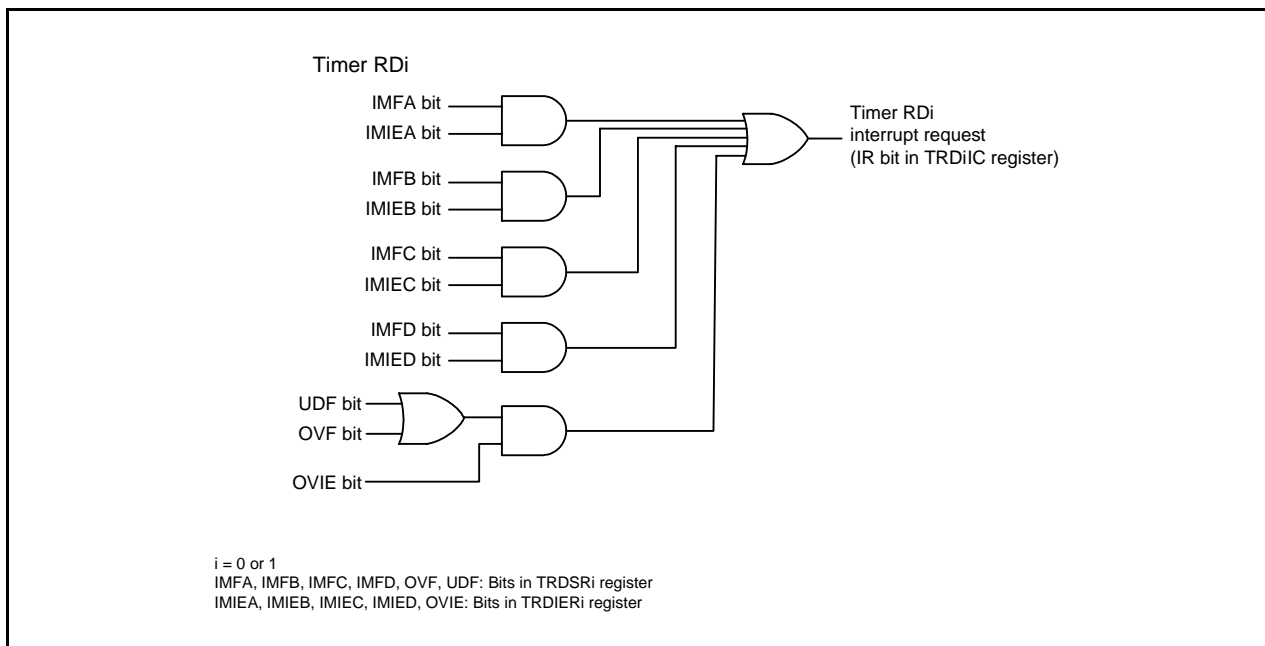

Figure 11.12 Block Diagram of Timer RD Interrupt

As with other maskable interrupts, the timer RC interrupt, timer RD (timer RD0) interrupt, timer RD (timer RD1) interrupt, synchronous serial communication unit interrupt, and flash memory interrupt are controlled by the combination of the I flag, IR bit, bits ILVL0 to ILVL2, and IPL. However, since each interrupt source is generated by a combination of multiple interrupt request sources, the following differences from other maskable interrupts apply:

- When bits in the enable register are set to 1 and the corresponding bits in the status register are set to 1 (interrupt enabled), the IR bit in the interrupt control register is set to 1 (interrupt requested).
- When either bits in the status register or the corresponding bits in the enable register, or both are set to 0, the IR bit is set to 0 (no interrupt requested).
That is, even if the interrupt is not acknowledged after the IR bit is set to 1, the interrupt request will not be retained.
Also, the IR bit is not set to 0 even if 0 is written to this bit.
- Individual bits in the status register are not automatically set to 0 even if the interrupt is acknowledged.
The IR bit is also not automatically set to 0 when the interrupt is acknowledged.
Set individual bits in the status register to 0 in the interrupt routine. Refer to the status register figure for how to set individual bits in the status register to 0.
- When multiple bits in the enable register are set to 1 and other request sources are generated after the IR bit is set to 1, the IR bit remains 1.
- When multiple bits in the enable register are set to 1, use the status register to determine which request source causes an interrupt.

Refer to chapters of the individual peripheral functions (**19. Timer RC**, **20. Timer RD**, **23. Synchronous Serial Communication Unit (SSU)**, and **28. Flash Memory**) for the status register and enable register.

For the interrupt control register, refer to **11.3 Interrupt Control**.

11.8 Notes on Interrupts

11.8.1 Reading Address 00000h

Do not read address 00000h by a program. When a maskable interrupt request is acknowledged, the CPU reads interrupt information (interrupt number and interrupt request level) from 00000h in the interrupt sequence. At this time, the IR bit for the acknowledged interrupt is set to 0.

If address 00000h is read by a program, the IR bit for the interrupt which has the highest priority among the enabled interrupts is set to 0. This may cause the interrupt to be canceled, or an unexpected interrupt to be generated.

11.8.2 SP Setting

Set a value in the SP before an interrupt is acknowledged. The SP is set to 0000h after a reset. If an interrupt is acknowledged before setting a value in the SP, the program may run out of control.

11.8.3 External Interrupt and Key Input Interrupt

Either the “L” level width or “H” level width shown in the Electrical Characteristics is required for the signal input to pins $\overline{\text{INT0}}$ to $\overline{\text{INT1}}$, $\overline{\text{INT3}}$ and pins $\overline{\text{KI0}}$ to $\overline{\text{KI3}}$, regardless of the CPU clock.

For details, refer to **Table 30.23** (VCC = 5V), **Table 30.30** (VCC = 3V) **External Interrupt $\overline{\text{INTi}}$ (i = 0 to 1, 3) Input, Key Input Interrupt $\overline{\text{KIi}}$ (i = 0 to 3)**.

11.8.4 Changing Interrupt Sources

The IR bit in the interrupt control register may be set to 1 (interrupt requested) when the interrupt source changes. To use an interrupt, set the IR bit to 0 (no interrupt requested) after changing interrupt sources. Changing interrupt sources as referred to here includes all factors that change the source, polarity, or timing of the interrupt assigned to a software interrupt number. Therefore, if a mode change of a peripheral function involves the source, polarity, or timing of an interrupt, set the IR bit to 0 (no interrupt requested) after making these changes. Refer to the descriptions of the individual peripheral functions for related interrupts. Figure 11.13 shows a Procedure Example for Changing Interrupt Sources.

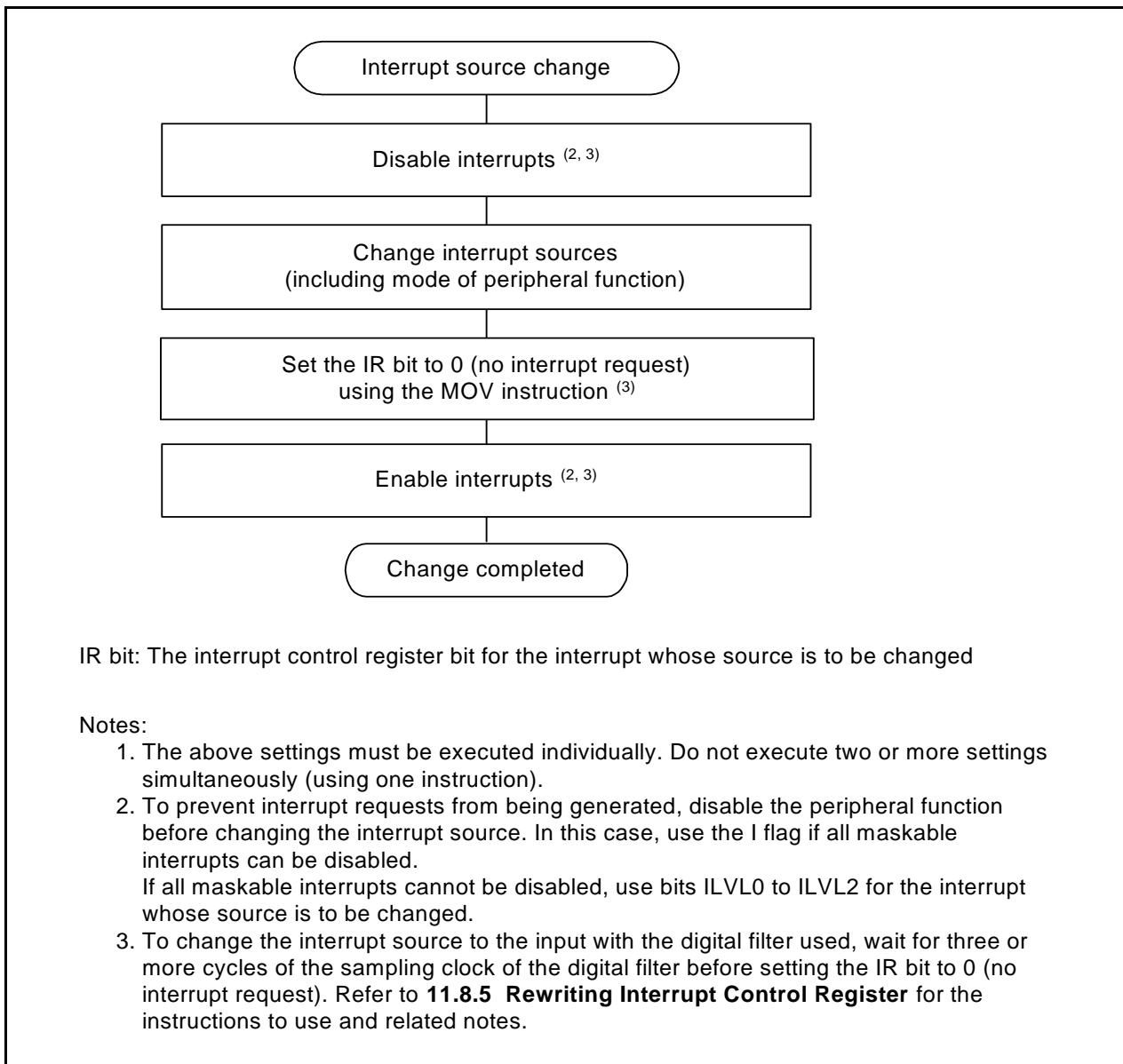

Figure 11.13 Procedure Example for Changing Interrupt Sources

11.8.5 Rewriting Interrupt Control Register

- (a) The contents of the interrupt control register can be rewritten only while no interrupt requests corresponding to that register are generated. If an interrupt request may be generated, disable the interrupt before rewriting the contents of the interrupt control register.
- (b) When rewriting the contents of the interrupt control register after disabling the interrupt, be careful to choose appropriate instructions.

Changing any bit other than the IR bit

If an interrupt request corresponding to the register is generated while executing the instruction, the IR bit may not be set to 1 (interrupt requested), and the interrupt may be ignored. If this causes a problem, use one of the following instructions to rewrite the contents of the register: AND, OR, BCLR, and BSET.

Changing the IR bit

Depending on the instruction used, the IR bit may not be set to 0 (no interrupt requested). Use the MOV instruction to set the IR bit to 0.

- (c) When using the I flag to disable an interrupt, set the I flag as shown in the sample programs below. Refer to (b) regarding rewriting the contents of interrupt control registers using the sample programs.

Examples 1 to 3 shows how to prevent the I flag from being set to 1 (interrupts enabled) before the contents of the interrupt control register are rewritten for the effects of the internal bus and the instruction queue buffer.

Example 1: Use the NOP instructions to pause program until the interrupt control register is rewritten

```
INT_SWITCH1:
  FCLR   I           ; Disable interrupts
  AND.B  #00H,0056H ; Set the TRAIC register to 00h
  NOP                    ;
  NOP                    ;
  FSET   I           ; Enable interrupts
```

Example 2: Use a dummy read to delay the FSET instruction

```
INT_SWITCH2:
  FCLR   I           ; Disable interrupts
  AND.B  #00H,0056H ; Set the TRAIC register to 00h
  MOV.W  MEM,R0      ; Dummy read
  FSET   I           ; Enable interrupts
```

Example 3: Use the POPC instruction to change the I flag

```
INT_SWITCH3:
  PUSHC  FLG
  FCLR   I           ; Disable interrupts
  AND.B  #00H,0056H ; Set the TRAIC register to 00h
  POPC   FLG         ; Enable interrupts
```

12. ID Code Areas

The ID code areas are used to implement a function that prevents the flash memory from being rewritten in standard serial I/O mode. This function prevents the flash memory from being read, rewritten, or erased.

12.1 Overview

The ID code areas are assigned to 0FFDFh, 0FFE3h, 0FFEb, 0FFEf, 0FFF3h, 0FFF7h, and 0FFFBh of the respective vector highest-order addresses of the fixed vector table. Figure 12.1 shows the ID Code Areas.

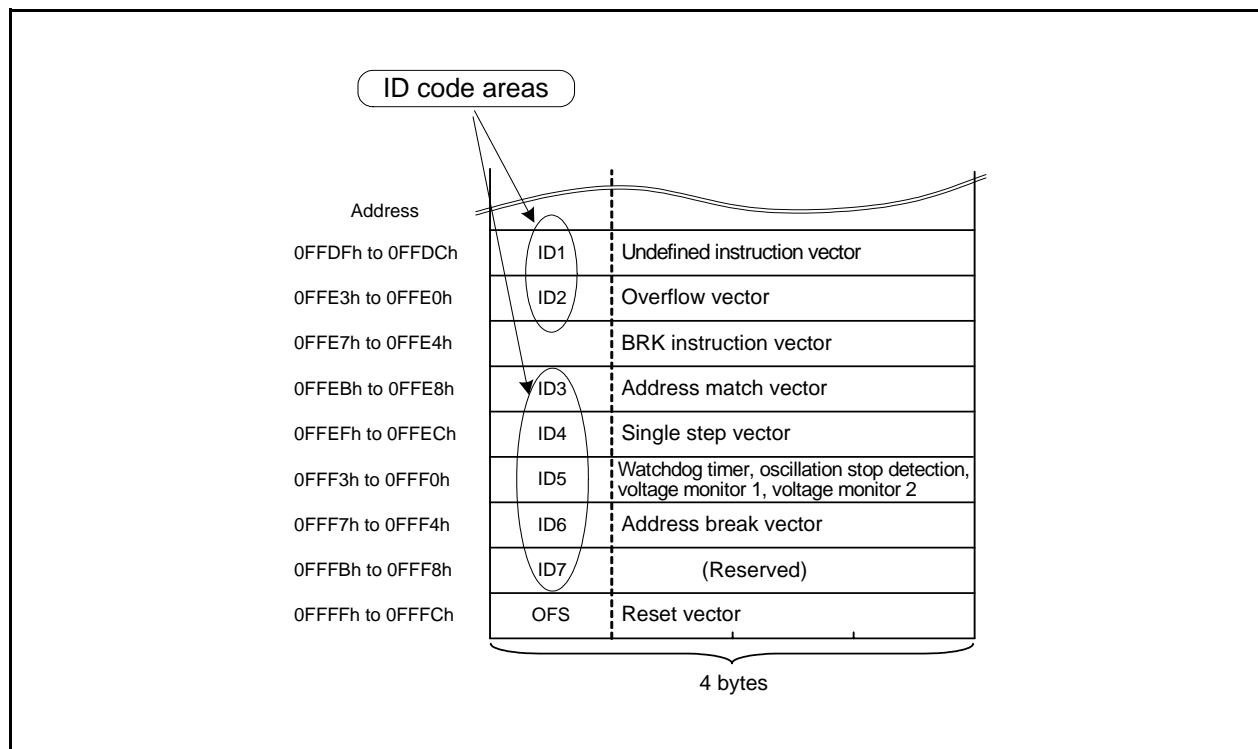

Figure 12.1 ID Code Areas

12.2 Functions

The ID code areas are used in standard serial I/O mode. Unless 3 bytes (addresses 0FFFCh to 0FFFEh) of the reset vector are set to FFFFFFFh, the ID codes stored in the ID code areas and the ID codes sent from the serial programmer or the on-chip debugging emulator are checked to see if they match. If the ID codes match, the commands sent from the serial programmer or the on-chip debugging emulator are acknowledged. If the ID codes do not match, the commands are not acknowledged. To use the serial programmer or the on-chip debugging emulator, first write predetermined ID codes to the ID code areas.

If 3 bytes (addresses 0FFFCh to 0FFFEh) of the reset vector are set to FFFFFFFh, the ID codes are not checked and all commands are accepted.

The ID code areas are allocated in the flash memory, not in the SFRs. Set appropriate values as ROM data by a program.

The character sequence of the ASCII codes “ALeRASE” is the reserved word used for the forced erase function. The character sequence of the ASCII codes “Protect” is the reserved word used for the standard serial I/O mode disabled function. Table 12.1 shows the ID Code Reserved Word. The reserved word is a set of reserved characters when all the addresses and data in the ID code storage addresses sequentially match Table 12.1. When the forced erase function or standard serial I/O mode disabled function is not used, use another character sequence of the ASCII codes.

Table 12.1 ID Code Reserved Word

ID Code Storage Address		ID Code Reserved Word (ASCII) ⁽¹⁾	
		ALeRASE	Protect
0FFDFh	ID1	41h (upper-case “A”)	50h (upper-case “P”)
0FFE3h	ID2	4Ch (upper-case “L”)	72h (lower-case “r”)
0FFEbH	ID3	65h (lower-case “e”)	6Fh (lower-case “o”)
0FFEFh	ID4	52h (upper-case “R”)	74h (lower-case “t”)
0FFF3h	ID5	41h (upper-case “A”)	65h (lower-case “e”)
0FFF7h	ID6	53h (upper-case “S”)	63h (lower-case “c”)
0FFFBh	ID7	45h (upper-case “E”)	74h (lower-case “t”)

Note:

1. Reserve word: A set of characters when all the addresses and data in the ID code storage addresses sequentially match Table 12.1.

12.3 Forced Erase Function

This function is used in standard serial I/O mode. When the ID codes sent from the serial programmer or the on-chip debugging emulator are “ALeRASE” in ASCII code, the content of the user ROM area will be erased at once. However, if the contents of the ID code addresses are set to other than “ALeRASE” (other than **Table 12.1 ID Code Reserved Word**) when the ROMCR bit in the OFS register is set to 1 and the ROMCP1 bit is set to 0 (ROM code protect enabled), forced erasure is not executed and the ID codes are checked with the ID code check function. Table 12.2 lists the Conditions and Operations of Forced Erase Function.

Also, when the contents of the ID code addresses are set to “ALeRASE” in ASCII code, if the ID codes sent from the serial programmer or the on-chip debugging emulator are “ALeRASE”, the content of the user ROM area will be erased. If the ID codes sent from the serial programmer are other than “ALeRASE”, the ID codes do not match and no command is acknowledged, thus the user ROM area remains protected.

Table 12.2 Conditions and Operations of Forced Erase Function

Condition			Operation
ID code from serial programmer or the on-chip debugging emulator	ID code in ID code storage address	Bits ROMCP1 and ROMCR in OFS register	
ALeRASE	ALeRASE	–	All erasure of user ROM area (forced erase function)
	Other than ALeRASE (1)	Other than 01b (ROM code protect disabled)	
		01b (ROM code protect enabled)	ID code check (ID code check function)
Other than ALeRASE	ALeRASE	–	ID code check (ID code check function. No ID code match.)
	Other than ALeRASE (1)	–	ID code check (ID code check function)

Note:

1. For “Protect”, refer to **12.4 Standard Serial I/O Mode Disabled Function**.

12.4 Standard Serial I/O Mode Disabled Function

This function is used in standard serial I/O mode. When the I/D codes in the ID code storage addresses are set to the reserved character sequence of the ASCII codes “Protect” (refer to **Table 12.1 ID Code Reserved Word**), communication with the serial programmer or the on-chip debugging emulator is not performed. This does not allow the flash memory to be read, rewritten, or erased using the serial programmer or the on-chip debugging emulator.

Also, if the ID codes are also set to the reserved character sequence of the ASCII codes “Protect” when the ROMCR bit in the OFS register is set to 1 and the ROMCP1 bit is set to 0 (ROM code protect enabled), ROM code protection cannot be disabled using the serial programmer or the on-chip debugging emulator. This prevents the flash memory from being read, rewritten, or erased using the serial programmer, the on-chip debugging emulator, or parallel programmer.

12.5 Notes on ID Code Areas

12.5.1 Setting Example of ID Code Areas

The ID code areas are allocated in the flash memory, not in the SFRs. Set appropriate values as ROM data by a program. The following shows a setting example.

- To set 55h in all of the ID code areas

```
.org 00FFDCH
.word dummy | (55000000h) ; UND
.word dummy | (55000000h) ; INTO
.word dummy ; BREAK
.word dummy | (55000000h) ; ADDRESS MATCH
.word dummy | (55000000h) ; SET SINGLE STEP
.word dummy | (55000000h) ; WDT
.word dummy | (55000000h) ; ADDRESS BREAK
.word dummy | (55000000h) ; RESERVE
```

(Programming formats vary depending on the compiler. Check the compiler manual.)

13. Option Function Select Area

13.1 Overview

The option function select area is used to select the MCU state after a reset, the function to prevent rewriting in parallel I/O mode, or the watchdog timer operation. The reset vector highest-order-address, 0FFFFh and 0FFDBh, are assigned as the option function select area. Figure 13.1 shows the Option Function Select Area.

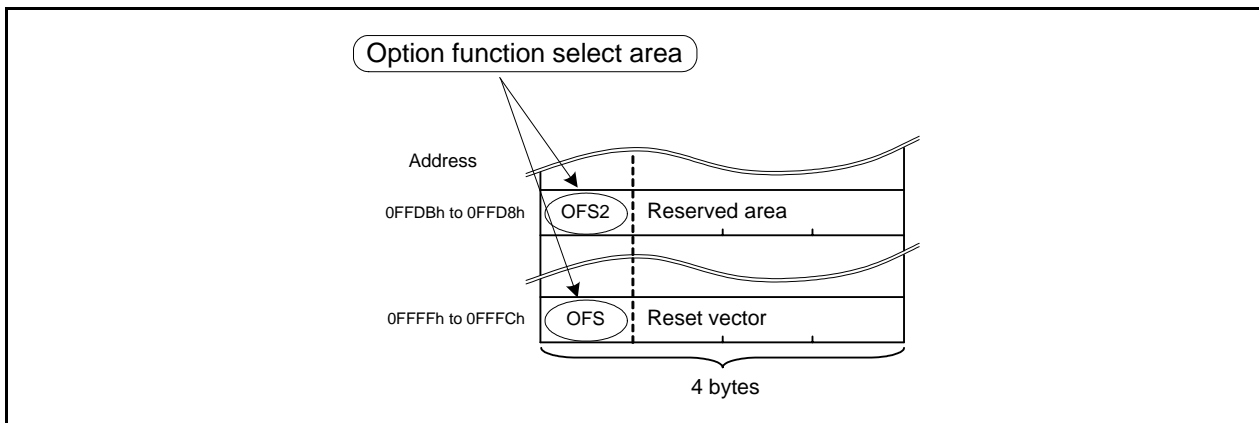

Figure 13.1 Option Function Select Area

13.2 Registers

Registers OFS and OFS2 are used to select the MCU state after a reset, the function to prevent rewriting in parallel I/O mode, or the watchdog timer operation.

13.2.1 Option Function Select Register (OFS)

Address 0FFFFh								
Bit	b7	b6	b5	b4	b3	b2	b1	b0
Symbol	CSPROINI	LVDAS	—	—	ROMCP1	ROMCR	—	WDTON
After Reset	User Setting Value ⁽¹⁾							

Bit	Symbol	Bit Name	Function	R/W
b0	WDTON	Watchdog timer start select bit	0: Watchdog timer automatically starts after reset 1: Watchdog timer is stopped after reset	R/W
b1	—	Reserved bit	Set to 1.	R/W
b2	ROMCR	ROM code protect disable bit	0: ROM code protect disabled 1: ROMCP1 bit enabled	R/W
b3	ROMCP1	ROM code protect bit	0: ROM code protect enabled 1: ROM code protect disabled	R/W
b4	—	Reserved bit	Set to 1.	R/W
b5	—	Reserved bit	Set to 0.	R/W
b6	LVDAS	Voltage detection 0 circuit start bit ⁽²⁾	0: Voltage monitor 0 reset enabled after reset 1: Voltage monitor 0 reset disabled after reset	R/W
b7	CSPROINI	Count source protection mode after reset select bit	0: Count source protect mode enabled after reset 1: Count source protect mode disabled after reset	R/W

Notes:

- The OFS register is allocated in the flash memory, not in the SFRs. Set appropriate values as ROM data by a program.
Do not write additions to the OFS register. If the block including the OFS register is erased, the OFS register is set to FFh.
When blank products are shipped, the OFS register is set to FFh. It is set to the written value after written by the user.
When factory-programming products are shipped, the value of the OFS register is the value programmed by the user.
- To use power-on reset and voltage monitor 0 reset, set the LVDAS bit to 0 (voltage monitor 0 reset enabled after reset).

For a setting example of the OFS register, refer to **13.3.1 Setting Example of Option Function Select Area**.

13.2.2 Option Function Select Register 2 (OFS2)

Address 0FFDBh	Bit	b7	b6	b5	b4	b3	b2	b1	b0
Symbol	—	—	—	—	WDTRCS1	WDTRCS0	WDTUFS1	WDTUFS0	
After Reset	User Setting Value ⁽¹⁾								

Bit	Symbol	Bit Name	Function	R/W
b0	WDTUFS0	Watchdog timer underflow period set bit	^{b1 b0} 0 0: 03FFh 0 1: 0FFFh 1 0: 1FFFh 1 1: 3FFFh	R/W
b1	WDTUFS1			R/W
b2	WDTRCS0	Watchdog timer refresh acknowledgement period set bit	^{b3 b2} 0 0: 25% 0 1: 50% 1 0: 75% 1 1: 100%	R/W
b3	WDTRCS1			R/W
b4	—	Reserved bits	Set to 1.	R/W
b5	—			
b6	—			
b7	—			

Note:

- The OFS2 register is allocated in the flash memory, not in the SFRs. Set appropriate values as ROM data by a program.
Do not write additions to the OFS2 register. If the block including the OFS2 register is erased, the OFS2 register is set to FFh.
When blank products are shipped, the OFS2 register is set to FFh. It is set to the written value after written by the user.
When factory-programming products are shipped, the value of the OFS2 register is the value programmed by the user.

For a setting example of the OFS2 register, refer to **13.3.1 Setting Example of Option Function Select Area**.

Bits WDTRCS0 and WDTRCS1 (Watchdog Timer Refresh Acknowledgement Period Set Bit)

Assuming that the period from when the watchdog timer starts counting until it underflows is 100%, the refresh acknowledgement period for the watchdog timer can be selected.
For details, refer to **14.3.1.1 Refresh Acknowledgement Period**.

13.3 Notes on Option Function Select Area

13.3.1 Setting Example of Option Function Select Area

The option function select area is allocated in the flash memory, not in the SFRs. Set appropriate values as ROM data by a program. The following shows a setting example.

- To set FFh in the OFS register

```
.org 00FFFCH
```

```
.lword reset | (0FF00000h) ; RESET
```

(Programming formats vary depending on the compiler. Check the compiler manual.)

- To set FFh in the OFS2 register

```
.org 00FFDBH
```

```
.byte 0FFh
```

(Programming formats vary depending on the compiler. Check the compiler manual.)

14. Watchdog Timer

The watchdog timer is a function that detects when a program is out of control. Use of the watchdog timer is recommended to improve the reliability of the system.

14.1 Overview

The watchdog timer contains a 14-bit counter and allows selection of count source protection mode enable or disable.

Table 14.1 lists the Watchdog Timer Specifications.

Refer to **5.5 Watchdog Timer Reset** for details of the watchdog timer reset.

Figure 14.1 shows a Watchdog Timer Block Diagram.

Table 14.1 Watchdog Timer Specifications

Item	Count Source Protection Mode Disabled	Count Source Protection Mode Enabled
Count source	CPU clock	Low-speed on-chip oscillator clock for the watchdog timer
Count operation	Decrement	
Count start condition	Either of the following can be selected: <ul style="list-style-type: none"> • After a reset, count starts automatically • Count starts by writing to the WDTS register 	
Count stop condition	Stop mode, wait mode	None
Watchdog timer initialization conditions	<ul style="list-style-type: none"> • Reset • Write 00h and then FFh to the WDTR register (with acknowledgement period setting) ⁽¹⁾ • Underflow 	
Operations at underflow	Watchdog timer interrupt or watchdog timer reset	Watchdog timer reset
Selectable functions	<ul style="list-style-type: none"> • Division ratio of the prescaler Selected by the WDTC7 bit in the WDTC register. • Count source protection mode Whether count source protection mode is enabled or disabled after a reset can be selected by the CSPROINI bit in the OFS register (flash memory). If count source protection mode is disabled after a reset, it can be enabled or disabled by the CSPRO bit in the CSPR register (program). • Start or stop of the watchdog timer after a reset Selected by the WDTON bit in the OFS register (flash memory). • Initial value of the watchdog timer Selectable by bits WDTUFS0 and WDTUFS1 in the OFS2 register. • Refresh acknowledgement period for the watchdog timer Selectable by bits WDTRCS0 and WDTRCS1 in the OFS2 register. 	

Note:

1. Write the WDTR register during the count operation of the watchdog timer.

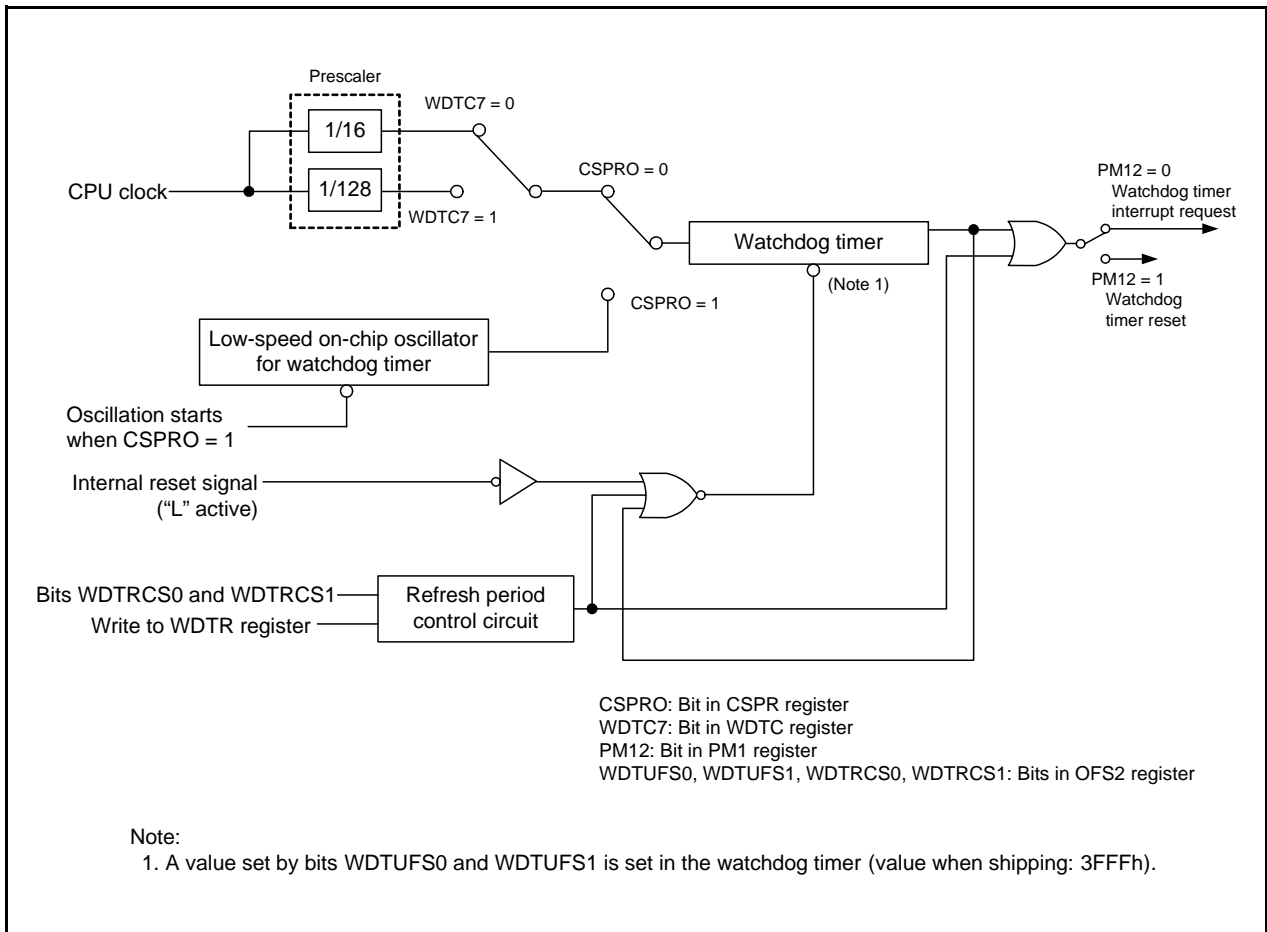

Figure 14.1 Watchdog Timer Block Diagram

14.2 Registers

14.2.1 Processor Mode Register 1 (PM1)

Address 0005h

Bit	b7	b6	b5	b4	b3	b2	b1	b0
Symbol	—	—	—	—	—	PM12	—	—
After Reset	0	0	0	0	0	0	0	0

Bit	Symbol	Bit Name	Function	R/W
b0	—	Reserved bits	Set to 0.	R/W
b1	—			
b2	PM12	WDT interrupt/reset switch bit	0: Watchdog timer interrupt 1: Watchdog timer reset ⁽¹⁾	R/W
b3	—	Nothing is assigned. If necessary, set to 0. When read, the content is 0.		—
b4	—			
b5	—			
b6	—			
b7	—	Reserved bit	Set to 0.	R/W

Note:

- The PM12 bit is set to 1 when 1 is written by a program (and remains unchanged even if 0 is written to it). This bit is automatically set to 1 when the CSPRO bit in the CSPR register is set to 1 (count source protection mode enabled).

Set the PRC1 bit in the PRCR register to 1 (write enabled) before rewriting the PM1 register.

14.2.2 Watchdog Timer Reset Register (WDTR)

Address 000Dh

Bit	b7	b6	b5	b4	b3	b2	b1	b0
Symbol	—	—	—	—	—	—	—	—
After Reset	X	X	X	X	X	X	X	X

Bit	Function	R/W
b7 to b0	Writing 00h and then FFh to this register initializes the watchdog timer. The initial value of the watchdog timer is specified by bits WDTUFS0 and WDTUF1 in the OFS2 register. ⁽¹⁾	W

Note:

- Write the WDTR register during the count operation of the watchdog timer.

14.2.3 Watchdog Timer Start Register (WDTs)

Address 000Eh

Bit	b7	b6	b5	b4	b3	b2	b1	b0
Symbol	—	—	—	—	—	—	—	—
After Reset	X	X	X	X	X	X	X	X

Bit	Function	R/W
b7 to b0	A write instruction to this register starts the watchdog timer.	W

14.2.4 Watchdog Timer Control Register (WDTC)

Address 000Fh

Bit	b7	b6	b5	b4	b3	b2	b1	b0
Symbol	WDTC7	—	—	—	—	—	—	—
After Reset	0	0	1	1	1	1	1	1

Bit	Symbol	Bit Name	Function	R/W
b0	—	The following bits of the watchdog timer can be read.		R
b1	—	When bits WDTUFS1 to WDTUFS0 in the OFS2 register are		R
b2	—	00b (03FFh): b5 to b0		R
b3	—	01b (0FFFh): b7 to b2		R
b4	—	10b (1FFFh): b8 to b3		R
b5	—	11b (3FFFh): b9 to b4		R
b6	—	Reserved bit	When read, the content is 0.	R
b7	WDTC7	Prescaler select bit	0: Divided-by-16 1: Divided-by-128	R/W

14.2.5 Count Source Protection Mode Register (CSPR)

Address 001Ch

Bit	b7	b6	b5	b4	b3	b2	b1	b0
Symbol	CSPRO	—	—	—	—	—	—	—
After Reset	0	0	0	0	0	0	0	0

The above applies when the CSPROINI bit in the OFS register is set to 1.

After Reset	1	0	0	0	0	0	0	0
-------------	---	---	---	---	---	---	---	---

The above applies when the CSPROINI bit in the OFS register is set to 0.

Bit	Symbol	Bit Name	Function	R/W
b0	—	Reserved bits		Set to 0.
b1	—			
b2	—			
b3	—			
b4	—			
b5	—			
b6	—			
b7	CSPRO	Count source protection mode select bit ⁽¹⁾	0: Count source protection mode disabled 1: Count source protection mode enabled	R/W

Note:

- To set the CSPRO bit to 1, write 0 and then 1 to it. This bit cannot be set to 0 by a program. Disable interrupts and DTC activation between writing 0 and writing 1.

14.2.6 Option Function Select Register (OFS)

Address 0FFFFh	Bit	b7	b6	b5	b4	b3	b2	b1	b0
Symbol	CSPROINI	LVDAS	—	—	ROMCP1	ROMCR	—	WDTON	
After Reset	User Setting Value ⁽¹⁾								

Bit	Symbol	Bit Name	Function	R/W
b0	WDTON	Watchdog timer start select bit	0: Watchdog timer automatically starts after reset 1: Watchdog timer is stopped after reset	R/W
b1	—	Reserved bit	Set to 1.	R/W
b2	ROMCR	ROM code protect disable bit	0: ROM code protect disabled 1: ROMCP1 bit enabled	R/W
b3	ROMCP1	ROM code protect bit	0: ROM code protect enabled 1: ROM code protect disabled	R/W
b4	—	Reserved bit	Set to 1.	R/W
b5	—	Reserved bit	Set to 0.	R/W
b6	LVDAS	Voltage detection 0 circuit start bit ⁽²⁾	0: Voltage monitor 0 reset enabled after reset 1: Voltage monitor 0 reset disabled after reset	R/W
b7	CSPROINI	Count source protection mode after reset select bit	0: Count source protect mode enabled after reset 1: Count source protect mode disabled after reset	R/W

Notes:

1. The OFS register is allocated in the flash memory, not in the SFRs. Set appropriate values as ROM data by a program.
Do not write additions to the OFS register. If the block including the OFS register is erased, the OFS register is set to FFh.
When blank products are shipped, the OFS register is set to FFh. It is set to the written value after written by the user.
When factory-programming products are shipped, the value of the OFS register is the value programmed by the user.
2. To use power-on reset and voltage monitor 0 reset, set the LVDAS bit to 0 (voltage monitor 0 reset enabled after reset).

For a setting example of the OFS register, refer to **13.3.1 Setting Example of Option Function Select Area**.

14.2.7 Option Function Select Register 2 (OFS2)

Address 0FFDBh								
Bit	b7	b6	b5	b4	b3	b2	b1	b0
Symbol	—	—	—	—	WDTRCS1	WDTRCS0	WDTUFS1	WDTUFS0
After Reset	User Setting Value ⁽¹⁾							

Bit	Symbol	Bit Name	Function	R/W
b0	WDTUFS0	Watchdog timer underflow period set bit	^{b1 b0} 0 0: 03FFh 0 1: 0FFFh 1 0: 1FFFh 1 1: 3FFFh	R/W
b1	WDTUFS1			R/W
b2	WDTRCS0	Watchdog timer refresh acknowledgement period set bit	^{b3 b2} 0 0: 25% 0 1: 50% 1 0: 75% 1 1: 100%	R/W
b3	WDTRCS1			R/W
b4	—	Reserved bits	Set to 1.	R/W
b5	—			
b6	—			
b7	—			

Note:

- The OFS2 register is allocated in the flash memory, not in the SFRs. Set appropriate values as ROM data by a program.
Do not write additions to the OFS2 register. If the block including the OFS2 register is erased, the OFS2 register is set to FFh.
When blank products are shipped, the OFS2 register is set to FFh. It is set to the written value after written by the user.
When factory-programming products are shipped, the value of the OFS2 register is the value programmed by the user.

For a setting example of the OFS2 register, refer to **13.3.1 Setting Example of Option Function Select Area**.

Bits WDTRCS0 and WDTRCS1 (Watchdog Timer Refresh Acknowledgement Period Set Bit)

Assuming that the period from when the watchdog timer starts counting until it underflows is 100%, the refresh acknowledgement period for the watchdog timer can be selected.

For details, refer to **14.3.1.1 Refresh Acknowledgement Period**.

14.3 Functional Description

14.3.1 Common Items for Multiple Modes

14.3.1.1 Refresh Acknowledgement Period

The period for acknowledging refreshment operation to the watchdog timer (write to the WDTR register) can be selected by bits WDTRCS0 and WDTRCS1 in the OFS2 register. Figure 14.2 shows the Refresh Acknowledgement Period for Watchdog Timer.

Assuming that the period from when the watchdog timer starts counting until it underflows is 100%, a refresh operation executed during the refresh acknowledgement period is acknowledged. Any refresh operation executed during the period other than the above is processed as an incorrect write, and a watchdog timer interrupt or watchdog timer reset (selectable by the PM12 bit in the PM1 register) is generated.

Do not execute any refresh operation while the count operation of the watchdog timer is stopped.

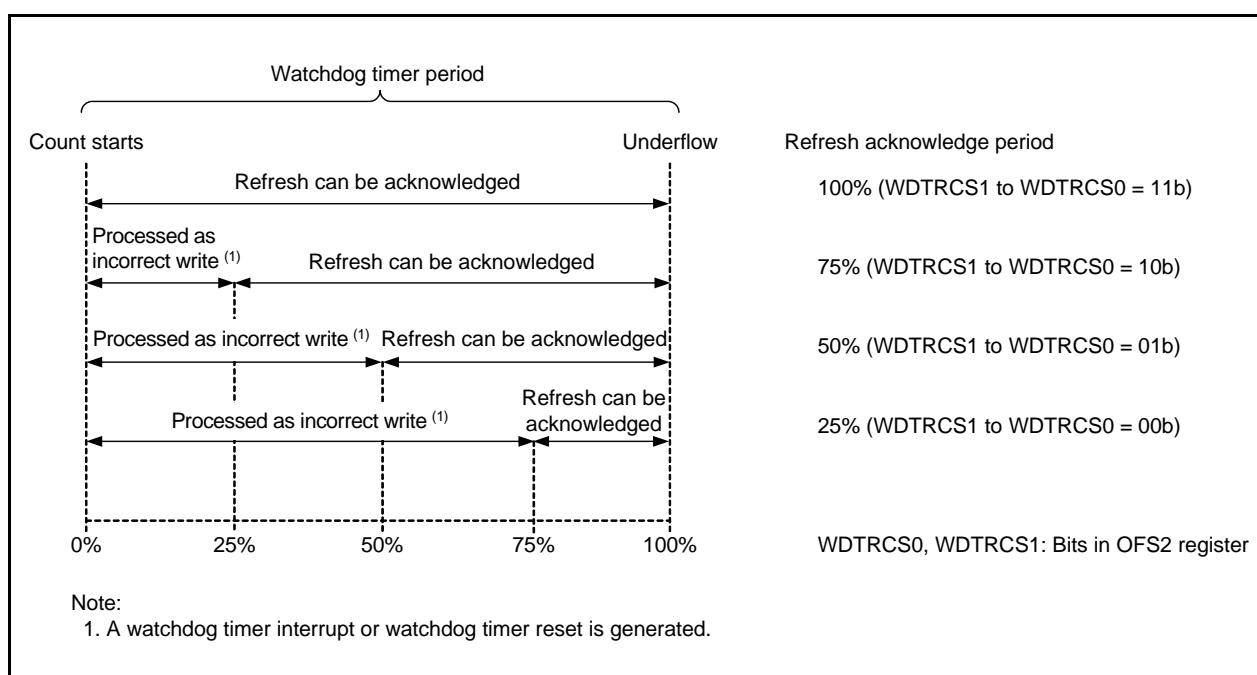

Figure 14.2 Refresh Acknowledgement Period for Watchdog Timer

14.3.2 Count Source Protection Mode Disabled

The count source for the watchdog timer is the CPU clock when count source protection mode is disabled. Table 14.2 lists the Watchdog Timer Specifications (Count Source Protection Mode Disabled).

Table 14.2 Watchdog Timer Specifications (Count Source Protection Mode Disabled)

Item	Specification
Count source	CPU clock
Count operation	Decrement
Period	$\frac{\text{Division ratio of prescaler (n)} \times \text{count value of watchdog timer (m)}^{(1)}}{\text{CPU clock}}$ <p>n: 16 or 128 (selected by the WDTC7 bit in the WDTC register) m: Value set by bits WDTUFS0 and WDTUFS1 in the OFS2 register Example: The period is approximately 13.1 ms when: - The CPU clock frequency is set to 20 MHz. - The prescaler is divided by 16. - Bits WDTUFS1 to WDTUFS0 are set to 11b (3FFFh).</p>
Watchdog timer initialization conditions	<ul style="list-style-type: none"> • Reset • Write 00h and then FFh to the WDTR register. ⁽³⁾ • Underflow
Count start conditions	<p>The operation of the watchdog timer after a reset is selected by the WDTON bit ⁽²⁾ in the OFS register (address 0FFFFh).</p> <ul style="list-style-type: none"> • When the WDTON bit is set to 1 (watchdog timer is stopped after reset). The watchdog timer and prescaler are stopped after a reset and start counting when the WDTS register is written to. • When the WDTON bit is set to 0 (watchdog timer starts automatically after reset). The watchdog timer and prescaler start counting automatically after a reset.
Count stop condition	Stop mode, wait mode (Count resumes from the retained value after exiting.)
Operations at underflow	<ul style="list-style-type: none"> • When the PM12 bit in the PM1 register is set to 0. Watchdog timer interrupt • When the PM12 bit in the PM1 register is set to 1. Watchdog timer reset (refer to 5.5 Watchdog Timer Reset)

Notes:

1. The watchdog timer is initialized when 00h and then FFh is written to the WDTR register. The prescaler is initialized after a reset. This may cause some errors due to the prescaler during the watchdog timer period.
2. The WDTON bit cannot be changed by a program. To set this bit, write 0 to bit 0 of address 0FFFFh with a flash programmer.
3. Write the WDTR register during the count operation of the watchdog timer.

14.3.3 Count Source Protection Mode Enabled

The count source for the watchdog timer is the low-speed on-chip oscillator clock for the watchdog timer when count source protection mode is enabled. If the CPU clock stops when a program is out of control, the clock can still be supplied to the watchdog timer.

Table 14.3 lists the Watchdog Timer Specifications (Count Source Protection Mode Enabled).

Table 14.3 Watchdog Timer Specifications (Count Source Protection Mode Enabled)

Item	Specification
Count source	Low-speed on-chip oscillator clock
Count operation	Decrement
Period	<p style="text-align: center;">Count value of watchdog timer (m)</p> <p>Low-speed on-chip oscillator clock for the watchdog timer</p> <p>m: Value set by bits WDTUFS0 and WDTUFS1 in the OFS2 register Example: The period is approximately 8.2 ms when: - The on-chip oscillator clock for the watchdog timer is set to 125 kHz. - Bits WDTUFS1 to WDTUFS0 are set to 00b (03FFh).</p>
Watchdog timer initialization conditions	<ul style="list-style-type: none"> • Reset • Write 00h and then FFh to the WDTR register. ⁽³⁾ • Underflow
Count start conditions	<p>The operation of the watchdog timer after a reset is selected by the WDTON bit ⁽¹⁾ in the OFS register (address 0FFFFh).</p> <ul style="list-style-type: none"> • When the WDTON bit is set to 1 (watchdog timer is stopped after reset). The watchdog timer and prescaler are stopped after a reset and start counting when the WDTS register is written to. • When the WDTON bit is set to 0 (watchdog timer starts automatically after reset). The watchdog timer and prescaler start counting automatically after a reset.
Count stop condition	None (Count does not stop even in wait mode and stop mode once it starts.)
Operation at underflow	Watchdog timer reset (Refer to 5.5 Watchdog Timer Reset.)
Registers, bits	<ul style="list-style-type: none"> • When the CSPPRO bit in the CSPR register is set to 1 (count source protection mode enabled) ⁽²⁾, the following are set automatically: <ul style="list-style-type: none"> - The low-speed on-chip oscillator for the watchdog timer is on. - The PM12 bit in the PM1 register is set to 1 (watchdog timer reset when the watchdog timer underflows).

Notes:

1. The WDTON bit cannot be changed by a program. To set this bit, write 0 to bit 0 of address 0FFFFh with a flash programmer.
2. Even if 0 is written to the CSPROINI bit in the OFS register, the CSPRO bit is set to 1. The CSPROINI bit cannot be changed by a program. To set this bit, write 0 to bit 7 of address 0FFFFh with a flash programmer.
3. Write the WDTR register during the count operation of the watchdog timer.

15. DTC

The DTC (data transfer controller) is a function that transfers data between the SFR and on-chip memory without using the CPU. This chip incorporates one DTC channel. The DTC is activated by a peripheral function interrupt to perform data transfers. The DTC and CPU use the same bus, and the DTC takes priority over the CPU in using the bus.

To control DTC data transfers, control data comprised of a transfer source address, a transfer destination address, and operating modes are allocated in the DTC control data area. Each time the DTC is activated, the DTC reads control data to perform data transfers.

15.1 Overview

Table 15.1 shows the DTC Specifications.

Table 15.1 DTC Specifications

Item		Specification
Activation sources		28 sources
Allocatable control data		24 sets
Address space which can be transferred		64 Kbytes (00000h to 0FFFFh)
Maximum number of transfer times	Normal mode	256 times
	Repeat mode	255 times
Maximum size of block to be transferred	Normal mode	256 bytes
	Repeat mode	255 bytes
Unit of transfers		Byte
Transfer mode	Normal mode	Transfers end on completion of the transfer causing the DTCCTj register value to change from 1 to 0.
	Repeat mode	On completion of the transfer causing the DTCCTj register value to change from 1 to 0, the repeat area address is initialized and the DTRLDj register value is reloaded to the DTCCTj register to continue transfers.
Address control	Normal mode	Fixed or incremented
	Repeat mode	Addresses of the area not selected as the repeat area are fixed or incremented.
Priority of activation sources		Refer to Table 15.5 DTC Activation Sources and DTC Vector Addresses .
Interrupt request	Normal mode	When the data transfer causing the DTCCTj register value to change from 1 to 0 is performed, the activation source interrupt request is generated for the CPU, and interrupt handling is performed on completion of the data transfer.
	Repeat mode	When the data transfer causing the DTCCTj register value to change from 1 to 0 is performed while the RPTINT bit in the DTCCRj register is 1 (interrupt generation enabled), the activation source interrupt request is generated for the CPU, and interrupt handling is performed on completion of the transfer.
Transfer start		When bits DTCENi0 to DTCENi7 in the DTCENi registers are 1 (activation enabled), data transfer is started each time the corresponding DTC activation sources are generated.
Transfer stop	Normal mode	<ul style="list-style-type: none"> • When bits DTCENi0 to DTCENi7 are set to 0 (activation disabled). • When the data transfer causing the DTCCTj register value to change from 1 to 0 is completed.
	Repeat mode	<ul style="list-style-type: none"> • When bits DTCENi0 to DTCENi7 are set to 0 (activation disabled). • When the data transfer causing the DTCCTj register value to change from 1 to 0 is completed while the RPTINT bit is 1 (interrupt generation enabled).

i = 0 to 4, 6, j = 0 to 23

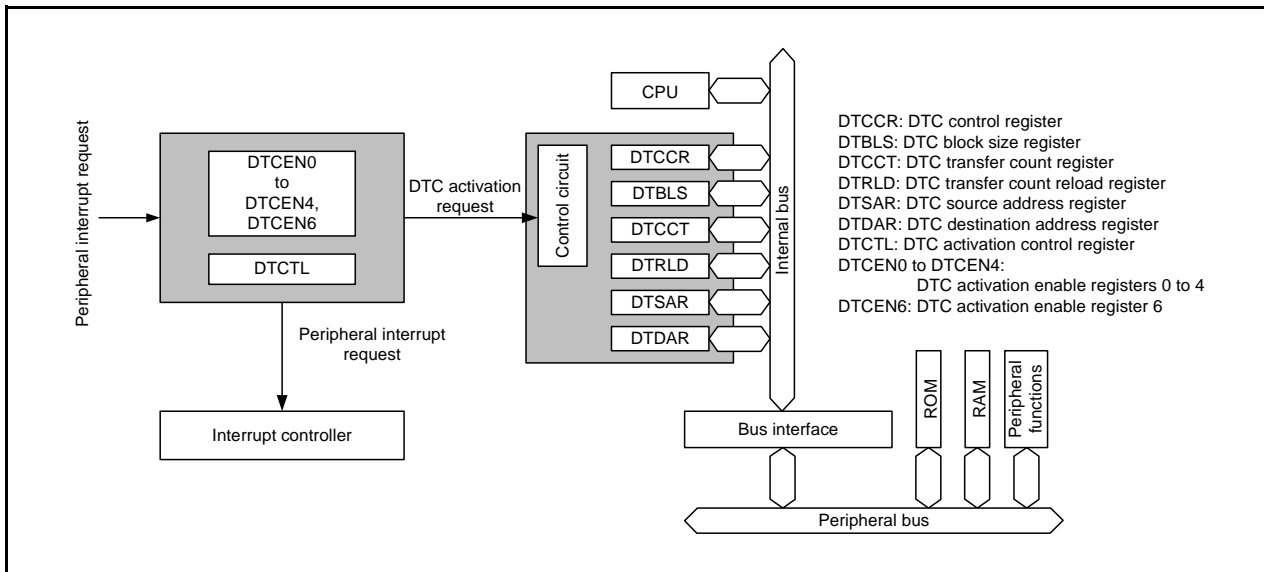

Figure 15.1 DTC Block Diagram

15.2 Registers

When the DTC is activated, control data (DTCCR_j, DTBLS_j, DTCCT_j, DTRLD_j, DTSAR_j, and DTDAR_j, $j = 0$ to 23) allocated in the control data area is read, and then transferred to the control registers (DTCCR, DTBLS, DTCCT, DTRLD, DTSAR, and DTDAR) in the DTC. On completion of the DTC data transfer, the contents of the DTC control registers are written back to the control data area.

Each DTCCR, DTBLS, DTCCT, DTRLD, DTSAR, and DTDAR register cannot be directly read or written to. DTCCR_j, DTBLS_j, DTCCT_j, DTRLD_j, DTSAR_j, and DTDAR_j are allocated as control data at addresses from 2C40h to 2CFFh in the DTC control data area, and can be directly accessed. Also, registers DTCTL and DTCEN_i ($i = 0$ to 4, 6) can be directly accessed.

15.2.1 DTC Control Register j (DTCCRj) (j = 0 to 23)

Address Refer to **Table 15.4 Control Data Allocation Addresses**.

Bit	b7	b6	b5	b4	b3	b2	b1	b0
Symbol	—	—	RPTINT	CHNE	DAMOD	SAMOD	RPTSEL	MODE
After Reset	X	X	X	X	X	X	X	X

Bit	Symbol	Bit Name	Function	R/W
b0	MODE	Transfer mode select bit	0: Normal mode 1: Repeat mode	R/W
b1	RPTSEL	Repeat area select bit ⁽¹⁾	0: Transfer destination is the repeat area. 1: Transfer source is the repeat area.	R/W
b2	SAMOD	Source address control bit ⁽²⁾	0: Fixed 1: Incremented	R/W
b3	DAMOD	Destination address control bit ⁽²⁾	0: Fixed 1: Incremented	R/W
b4	CHNE	Chain transfer enable bit ⁽³⁾	0: Chain transfers disabled 1: Chain transfers enabled	R/W
b5	RPTINT	Repeat mode interrupt enable bit ⁽¹⁾	0: Interrupt generation disabled 1: Interrupt generation enabled	R/W
b6	—	Reserved bits	Set to 0.	R/W
b7	—			

Notes:

1. This bit is valid when the MODE bit is 1 (repeat mode).
2. Settings of bits SAMOD and DAMOD are invalid for the repeat area.
3. Set the CHNE bit in the DTCCR23 register to 0 (chain transfers disabled).

15.2.2 DTC Block Size Register j (DTBLSj) (j = 0 to 23)

Address Refer to **Table 15.4 Control Data Allocation Addresses**.

Bit	b7	b6	b5	b4	b3	b2	b1	b0
Symbol	—	—	—	—	—	—	—	—
After Reset	X	X	X	X	X	X	X	X

Bit	Function	Setting Range	R/W
b7 to b0	These bits specify the size of the data block to be transferred by one activation.	00h to FFh ⁽¹⁾	R/W

Note:

1. When the DTBLS register is set to 00h, the block size is 256 bytes.

15.2.3 DTC Transfer Count Register j (DTCCTj) (j = 0 to 23)

Address Refer to **Table 15.4 Control Data Allocation Addresses**.

Bit	b7	b6	b5	b4	b3	b2	b1	b0
Symbol	—	—	—	—	—	—	—	—
After Reset	X	X	X	X	X	X	X	X

Bit	Function	Setting Range	R/W
b7 to b0	These bits specify the number of times of DTC data transfers.	00h to FFh ⁽¹⁾	R/W

Note:

- When the DTCCT register is set to 00h, the number of transfer times is 256. Each time the DTC is activated, the DTCCT register is decremented by 1.

15.2.4 DTC Transfer Count Reload Register j (DTRLj) (j = 0 to 23)

Address Refer to **Table 15.4 Control Data Allocation Addresses**.

Bit	b7	b6	b5	b4	b3	b2	b1	b0
Symbol	—	—	—	—	—	—	—	—
After Reset	X	X	X	X	X	X	X	X

Bit	Function	Setting Range	R/W
b7 to b0	This register value is reloaded to the DTCCT register in repeat mode.	00h to FFh ⁽¹⁾	R/W

Note:

- Set the initial value for the DTCCT register.

15.2.5 DTC Source Address Register j (DTSARj) (j = 0 to 23)

Address Refer to **Table 15.4 Control Data Allocation Addresses**.

Bit	b7	b6	b5	b4	b3	b2	b1	b0
Symbol	—	—	—	—	—	—	—	—
After Reset	X	X	X	X	X	X	X	X

Bit	b15	b14	b13	b12	b11	b10	b9	b8
Symbol	—	—	—	—	—	—	—	—
After Reset	X	X	X	X	X	X	X	X

Bit	Function	Setting Range	R/W
b15 to b0	These bits specify a transfer source address for data transfer.	0000h to FFFFh	R/W

15.2.6 DTC Destination Address Register j (DTDARj) (j = 0 to 23)

Address Refer to **Table 15.4 Control Data Allocation Addresses**.

Bit	b7	b6	b5	b4	b3	b2	b1	b0
Symbol	—	—	—	—	—	—	—	—
After Reset	X	X	X	X	X	X	X	X

Bit	b15	b14	b13	b12	b11	b10	b9	b8
Symbol	—	—	—	—	—	—	—	—
After Reset	X	X	X	X	X	X	X	X

Bit	Function	Setting Range	R/W
b15 to b0	These bits specify a transfer destination address for data transfer.	0000h to FFFFh	R/W

15.2.7 DTC Activation Enable Register i (DTCENi) (i = 0 to 4, 6)

Address 0088h (DTCEN0), 0089h (DTCEN1), 008Ah (DTCEN2), 008Bh (DTCEN3), 008Ch (DTCEN4), 008Eh (DTCEN6)

Bit	b7	b6	b5	b4	b3	b2	b1	b0
Symbol	DTCENi7	DTCENi6	DTCENi5	DTCENi4	DTCENi3	DTCENi2	DTCENi1	DTCENi0
After Reset	0	0	0	0	0	0	0	0

Bit	Symbol	Bit Name	Function	R/W
b0	DTCENi0	DTC activation enable bit (1)	0: Activation disabled 1: Activation enabled	R/W
b1	DTCENi1			R/W
b2	DTCENi2			R/W
b3	DTCENi3			R/W
b4	DTCENi4			R/W
b5	DTCENi5			R/W
b6	DTCENi6			R/W
b7	DTCENi7			R/W

i = 0 to 4, 6

Note:

- For the operation of this bit, refer to **15.3.7 Interrupt Sources**.

The DTCENi registers enable/disable DTC activation by interrupt sources. Table 15.2 shows Correspondences between Bits DTCENi0 to DTCENi7 (i = 0 to 4, 6) and Interrupt Sources.

Table 15.2 Correspondences between Bits DTCENi0 to DTCENi7 (i = 0 to 4, 6) and Interrupt Sources

Register	DTCENi7 Bit	DTCENi6 Bit	DTCENi5 Bit	DTCENi4 Bit	DTCENi3 Bit	DTCENi2 Bit	DTCENi1 Bit	DTCENi0 Bit
DTCEN0	$\overline{\text{INT0}}$	$\overline{\text{INT1}}$	—	$\overline{\text{INT3}}$	—	—	—	—
DTCEN1	Key input	A/D conversion	UART0 reception	UART0 transmission	—	—	UART2 reception	UART2 transmission
DTCEN2	SSU receive data full	SSU transmit data empty	Voltage Monitor 2	Voltage Monitor 1	—	—	Timer RC input-capture/compare-match A	Timer RC input-capture/compare-match B
DTCEN3	Timer RC input-capture/compare-match C	Timer RC input-capture/compare-match D	Timer RD0 input-capture/compare-match A	Timer RD0 input-capture/compare-match B	Timer RD0 input-capture/compare-match C	Timer RD0 input-capture/compare-match D	Timer RD1 input-capture/compare-match A	Timer RD1 input-capture/compare-match B
DTCEN4	Timer RD1 input-capture/compare-match C	Timer RD1 input-capture/compare-match D	—	—	—	—	—	—
DTCEN6	—	Timer RA	—	Timer RB	Flash ready status	—	—	—

15.2.8 DTC Activation Control Register (DTCTL)

Address 0080h

Bit	b7	b6	b5	b4	b3	b2	b1	b0
Symbol	—	—	—	—	—	—	NMIF	—
After Reset	0	0	0	0	0	0	0	0

Bit	Symbol	Bit Name	Function	R/W
b0	—	Reserved bit	Set to 0.	R/W
b1	NMIF	Non-maskable interrupt generation bit (1)	0: Non-maskable interrupts not generated 1: Non-maskable interrupts generated	R/W
b2	—	Nothing is assigned. If necessary, set to 0. When read, the content is 0.		—
b3	—			
b4	—			
b5	—			
b6	—			
b7	—			

Note:

1. This bit is set to 0 when the read result is 1 and 0 is written to the same bit. This bit remains unchanged even if the read result is 0 and 0 is written to the same bit. This bit remains unchanged if 1 is written to it.

The DTCTL register controls DTC activation when a non-maskable interrupt (an interrupt by the watchdog timer, oscillation stop detection, voltage monitor 1, or voltage monitor 2) is generated.

NMIF Bit (Non-Maskable Interrupt Generation Bit)

The NMIF bit is set to 1 when a watchdog timer interrupt, an oscillation stop detection interrupt, a voltage monitor 1 interrupt, or a voltage monitor 2 interrupt is generated.

When the NMIF bit is 1, the DTC is not activated even if the interrupt which enables DTC activation is generated. If the NMIF bit is changed to 1 during DTC transfer, the transfer is continued until it is completed.

When an interrupt source is the watchdog timer, wait for the following cycles before writing 0 to the NMIF bit:
If the WDTC7 bit in the WDTC register is set to 0 (divide-by-16 using the prescaler), wait for 16 cycles of the CPU clock after the interrupt source is generated.

If the WDTC7 bit is set to 1 (divide-by-128 using the prescaler), wait for 128 cycles of the CPU clock after the interrupt source is generated.

When an interrupt source is oscillation stop detection, set to the OCD1 bit in the OCD register to 0 (oscillation stop detection interrupt disabled) before writing 0 to the NMIF bit.

15.3 Function Description

15.3.1 Overview

When the DTC is activated, control data is read from the DTC control data area to perform data transfers and control data after data transfer is written back to the DTC control data area. Twenty-four sets of control data can be stored in the DTC control data area, which allows 24 types of data transfers to be performed.

There are two transfer modes: normal mode and repeat mode. When the CHNE bit in the DTCCRj (j = 0 to 23) register is set to 1 (chain transfers enabled), multiple control data is read and data transfers are continuously performed by one activation source (chain transfers).

A transfer source address is specified by the 16-bit register DTSARj, and a transfer destination address is specified by the 16-bit register DTDARj. The values in the registers DTSARj and DTDARj are separately fixed or incremented according to the control data on completion of the data transfer.

15.3.2 Activation Sources

The DTC is activated by an interrupt source. Figure 15.2 is a Block Diagram Showing Control of DTC Activation Sources.

The interrupt sources to activate the DTC are selected with the DTCENi (i = 0 to 4, 6) registers.

The DTC sets 0 (activation disabled) to the corresponding bit among bits DTCENi0 to DTCENi7 in the DTCENi register during operation when the setting of data transfer (the first transfer in chain transfers) is either of the following:

- Transfer causing the DTCCTj (j = 0 to 23) register value to change to 0 in normal mode
- Transfer causing the DTCCTj register value to change to 0 while the RPTINT bit in the DTCCRj register is 1 (interrupt generation enabled) in repeat mode

If the data transfer setting is not either of the above and the activation source is an interrupt source for timer RC, timer RD, or the flash memory, the DTC sets 0 to the interrupt source flag corresponding to the activation source during operation.

Table 15.3 shows the DTC Activation Sources and Interrupt Source Flags for Setting to 0 during DTC Operation.

If multiple activation sources are simultaneously generated, the DTC activation will be performed according to the DTC activation source priority.

If multiple activation sources are simultaneously generated on completion of DTC operation, the next transfer will be performed according to the priority.

DTC activation is not affected by the I flag or interrupt control register, unlike with interrupt request operation. Therefore, even if interrupt requests cannot be acknowledged because interrupts are disabled, DTC activation requests can be acknowledged. The IR bit in the interrupt control register does not change even when an interrupt source to enable DTC activation is generated.

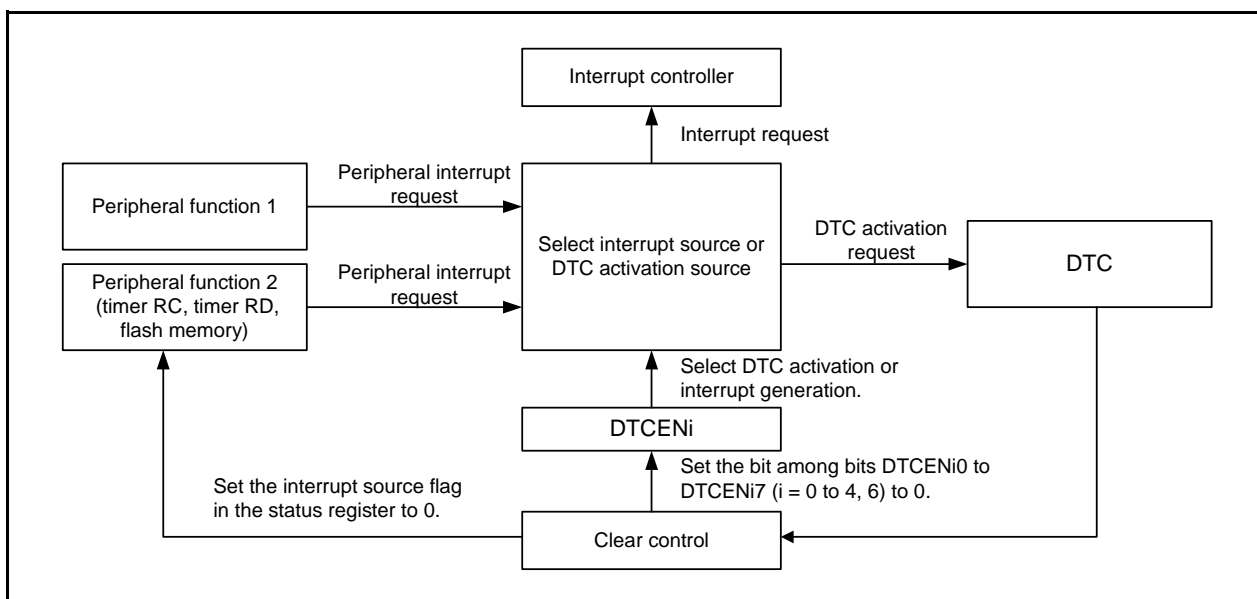

Figure 15.2 Block Diagram Showing Control of DTC Activation Sources

Table 15.3 DTC Activation Sources and Interrupt Source Flags for Setting to 0 during DTC Operation

DTC activation source generation	Interrupt Source Flag for Setting to 0
Timer RC input-capture/compare-match A	IMFA bit in TRCSR register
Timer RC input-capture/compare-match B	IMFB bit in TRCSR register
Timer RC input-capture/compare-match C	IMFC bit in TRCSR register
Timer RC input-capture/compare-match D	IMFD bit in TRCSR register
Timer RD0 input-capture/compare-match A	IMFA bit in TRDSR0 register
Timer RD0 input-capture/compare-match B	IMFB bit in TRDSR0 register
Timer RD0 input-capture/compare-match C	IMFC bit in TRDSR0 register
Timer RD0 input-capture/compare-match D	IMFD bit in TRDSR0 register
Timer RD1 input-capture/compare-match A	IMFA bit in TRDSR1 register
Timer RD1 input-capture/compare-match B	IMFB bit in TRDSR1 register
Timer RD1 input-capture/compare-match C	IMFC bit in TRDSR1 register
Timer RD1 input-capture/compare-match D	IMFD bit in TRDSR1 register
Flash ready status	RDYSTI bit in FST register

15.3.3 Control Data Allocation and DTC Vector Table

Control data is allocated in the order: Registers DTCCR_j, DTBLS_j, DTCCT_j, DTRLD_j, DTSAR_j, and DTDAR_j (j = 0 to 23). Table 15.4 shows the Control Data Allocation Addresses.

Table 15.4 Control Data Allocation Addresses

Register Symbol	Control Data No.	Address	DTCCR _j Register	DTBLS _j Register	DTCCT _j Register	DTRLD _j Register	DTSAR _j Register (Lower 8 Bits)	DTSAR _j Register (Higher 8 Bits)	DTDAR _j Register (Lower 8 Bits)	DTDAR _j Register (Higher 8 Bits)
DTCD0	Control Data 0	2C40h to 2C47h	2C40h	2C41h	2C42h	2C43h	2C44h	2C45h	2C46h	2C47h
DTCD1	Control Data 1	2C48h to 2C4Fh	2C48h	2C49h	2C4Ah	2C4Bh	2C4Ch	2C4Dh	2C4Eh	2C4Fh
DTCD2	Control Data 2	2C50h to 2C57h	2C50h	2C51h	2C52h	2C53h	2C54h	2C55h	2C56h	2C57h
DTCD3	Control Data 3	2C58h to 2C5Fh	2C58h	2C59h	2C5Ah	2C5Bh	2C5Ch	2C5Dh	2C5Eh	2C5Fh
DTCD4	Control Data 4	2C60h to 2C67h	2C60h	2C61h	2C62h	2C63h	2C64h	2C65h	2C66h	2C67h
DTCD5	Control Data 5	2C68h to 2C6Fh	2C68h	2C69h	2C6Ah	2C6Bh	2C6Ch	2C6Dh	2C6Eh	2C6Fh
DTCD6	Control Data 6	2C70h to 2C77h	2C70h	2C71h	2C72h	2C73h	2C74h	2C75h	2C76h	2C77h
DTCD7	Control Data 7	2C78h to 2C7Fh	2C78h	2C79h	2C7Ah	2C7Bh	2C7Ch	2C7Dh	2C7Eh	2C7Fh
DTCD8	Control Data 8	2C80h to 2C87h	2C80h	2C81h	2C82h	2C83h	2C84h	2C85h	2C86h	2C87h
DTCD9	Control Data 9	2C88h to 2C8Fh	2C88h	2C89h	2C8Ah	2C8Bh	2C8Ch	2C8Dh	2C8Eh	2C8Fh
DTCD10	Control Data 10	2C90h to 2C97h	2C90h	2C91h	2C92h	2C93h	2C94h	2C95h	2C96h	2C97h
DTCD11	Control Data 11	2C98h to 2C9Fh	2C98h	2C99h	2C9Ah	2C9Bh	2C9Ch	2C9Dh	2C9Eh	2C9Fh
DTCD12	Control Data 12	2CA0h to 2CA7h	2CA0h	2CA1h	2CA2h	2CA3h	2CA4h	2CA5h	2CA6h	2CA7h
DTCD13	Control Data 13	2CA8h to 2CAFh	2CA8h	2CA9h	2CAAh	2CABh	2CACH	2CADh	2CAEh	2CAFh
DTCD14	Control Data 14	2CB0h to 2CB7h	2CB0h	2CB1h	2CB2h	2CB3h	2CB4h	2CB5h	2CB6h	2CB7h
DTCD15	Control Data 15	2CB8h to 2CBFh	2CB8h	2CB9h	2CBAh	2CBBh	2CBCh	2CBDh	2CBEh	2CBFh
DTCD16	Control Data 16	2CC0h to 2CC7h	2CC0h	2CC1h	2CC2h	2CC3h	2CC4h	2CC5h	2CC6h	2CC7h
DTCD17	Control Data 17	2CC8h to 2CCFh	2CC8h	2CC9h	2CCAh	2CCBh	2CCCh	2CCDh	2CCEh	2CCFh
DTCD18	Control Data 18	2CD0h to 2CD7h	2CD0h	2CD1h	2CD2h	2CD3h	2CD4h	2CD5h	2CD6h	2CD7h
DTCD19	Control Data 19	2CD8h to 2CDFh	2CD8h	2CD9h	2CDAh	2CDBh	2CDCh	2CDDh	2CDEh	2CDFh
DTCD20	Control Data 20	2CE0h to 2CE7h	2CE0h	2CE1h	2CE2h	2CE3h	2CE4h	2CE5h	2CE6h	2CE7h
DTCD21	Control Data 21	2CE8h to 2CEFh	2CE8h	2CE9h	2CEAh	2CEBh	2CECh	2CEDh	2CEEh	2CEFh
DTCD22	Control Data 22	2CF0h to 2CF7h	2CF0h	2CF1h	2CF2h	2CF3h	2CF4h	2CF5h	2CF6h	2CF7h
DTCD23	Control Data 23	2CF8h to 2CFFh	2CF8h	2CF9h	2CFAh	2CFBh	2CFCh	2CFDh	2CFEh	2CFFh

j = 0 to 23

When the DTC is activated, one control data is selected according to the data read from the vector table which has been assigned to each activation source, and the selected control data is read from the DTC control data area.

Table 15.5 shows the DTC Activation Sources and DTC Vector Addresses. A one-byte vector table area is assigned to each activation source and one value from 00000000b to 00010111b (control data numbers in Table 15.4) is stored in each area to select one of the 24 control data sets.

Figures 15.3 to 15.7 show the DTC Internal Operation Flowchart.

Table 15.5 DTC Activation Sources and DTC Vector Addresses

Interrupt Request Source	Interrupt Name	Source No.	DTC Vector Address	Priority	
External input	INT0	0	2C00h		
	INT1	1	2C01h		
	INT3	3	2C03h		
Key input	Key input	8	2C08h		
A/D	A/D conversion	9	2C09h		
UART0	UART0 reception	10	2C0Ah		
	UART0 transmission	11	2C0Bh		
SSU	Receive data full	16	2C10h		
	Transmit data empty	17	2C11h		
Voltage detection circuit	Voltage monitor 2	18	2C12h		
	Voltage monitor 1	19	2C13h		
Timer RC	Input-capture/compare-match A	22	2C16h		
	Input-capture/compare-match B	23	2C17h		
	Input-capture/compare-match C	24	2C18h		
	Input-capture/compare-match D	25	2C19h		
Timer RD0	Input-capture/compare-match A	26	2C1Ah		
	Input-capture/compare-match B	27	2C1Bh		
	Input-capture/compare-match C	28	2C1Ch		
	Input-capture/compare-match D	29	2C1Dh		
Timer RD1	Input-capture/compare-match A	30	2C1Eh		
	Input-capture/compare-match B	31	2C1Fh		
	Input-capture/compare-match C	32	2C20h		
	Input-capture/compare-match D	33	2C21h		
Timer RA	Timer RA	49	2C31h		
Timer RB	Timer RB	51	2C33h		
Flash memory	Flash ready status	52	2C34h		Low

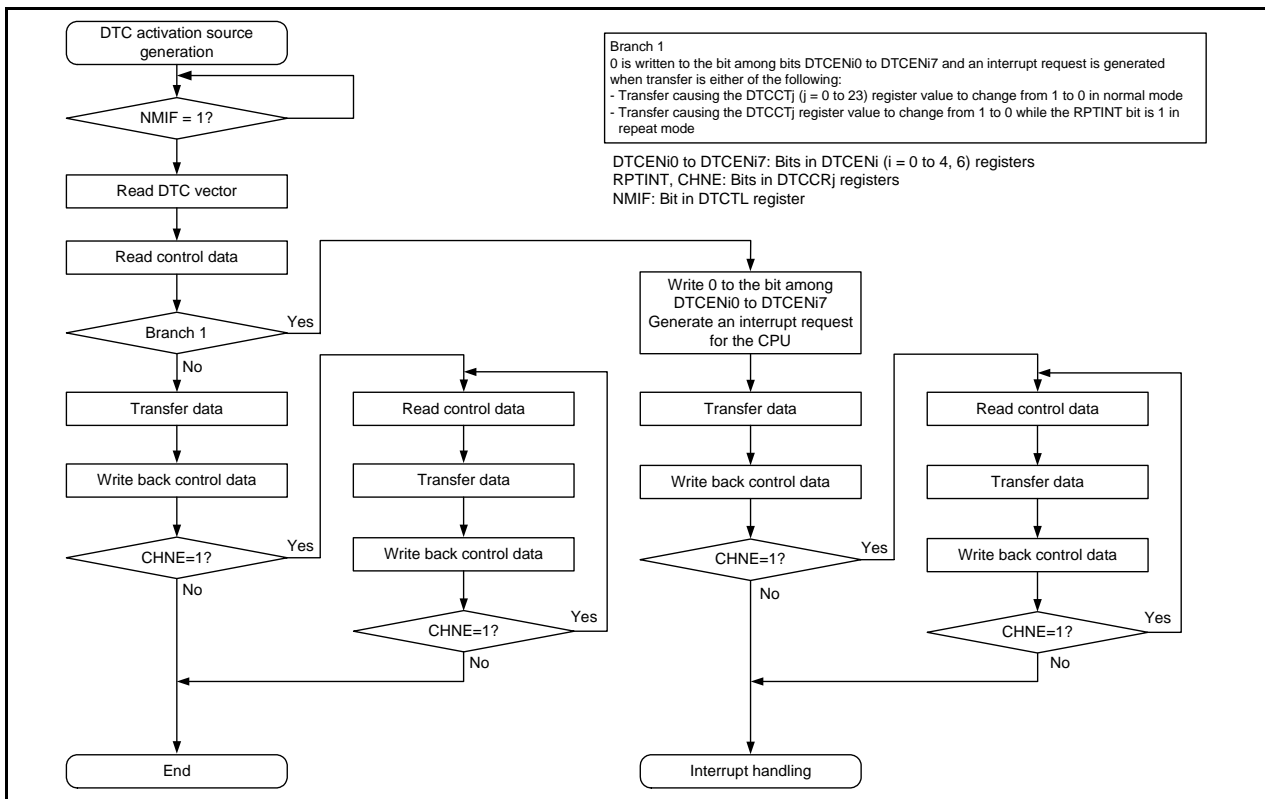

Figure 15.3 DTC Internal Operation Flowchart When DTC Activation Source is not SSU, Timer RC, Timer RD, or Flash Memory Interrupt Source

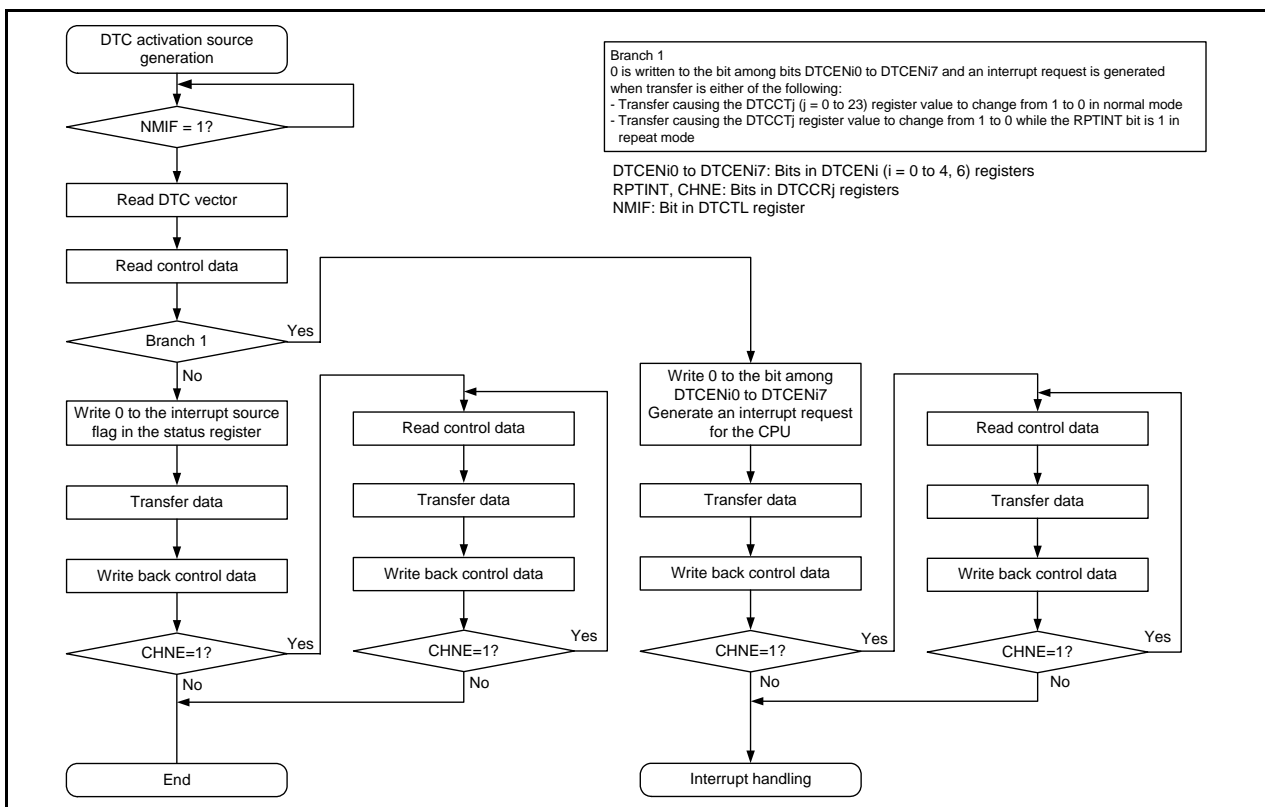

Figure 15.4 DTC Internal Operation Flowchart When DTC Activation Source is Timer RC or Timer RD Interrupt Source

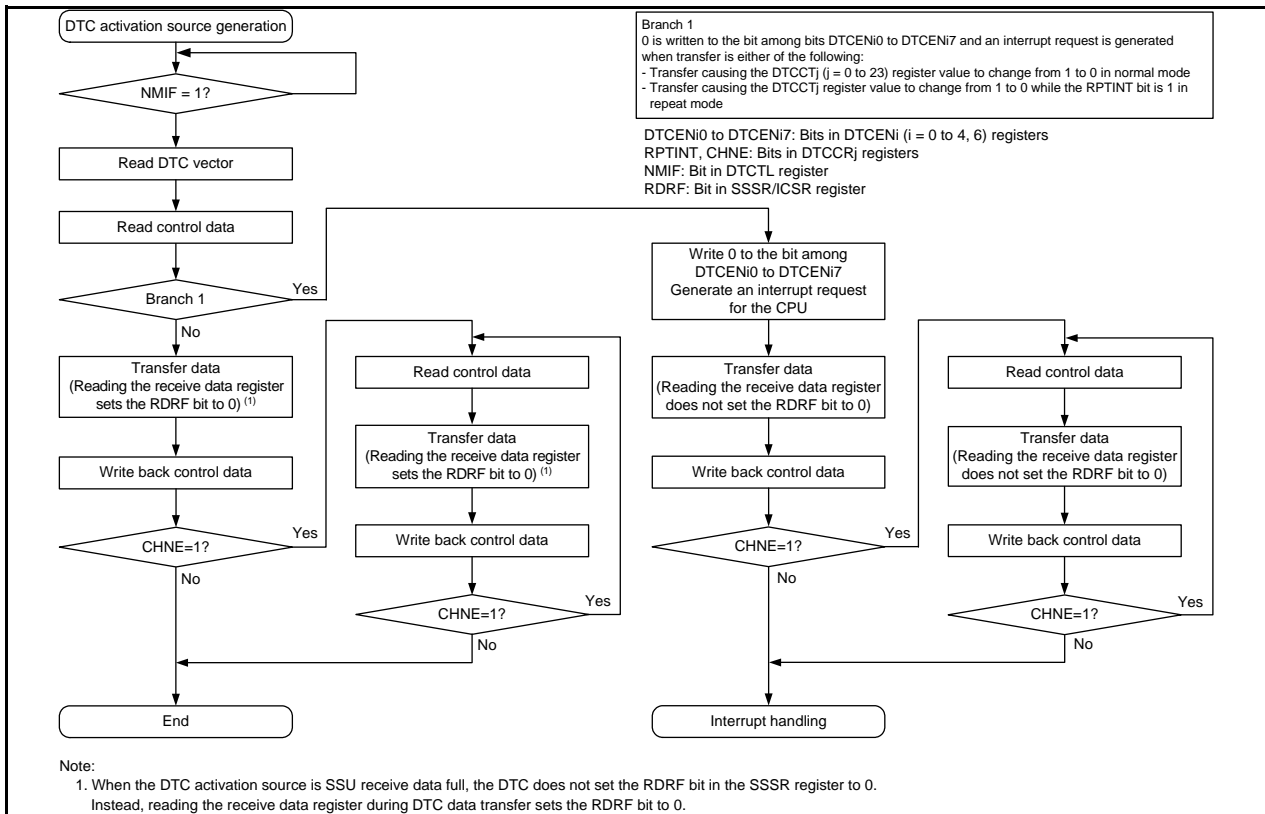

Figure 15.5 DTC Internal Operation Flowchart When DTC Activation Source is SSU Receive Data Full

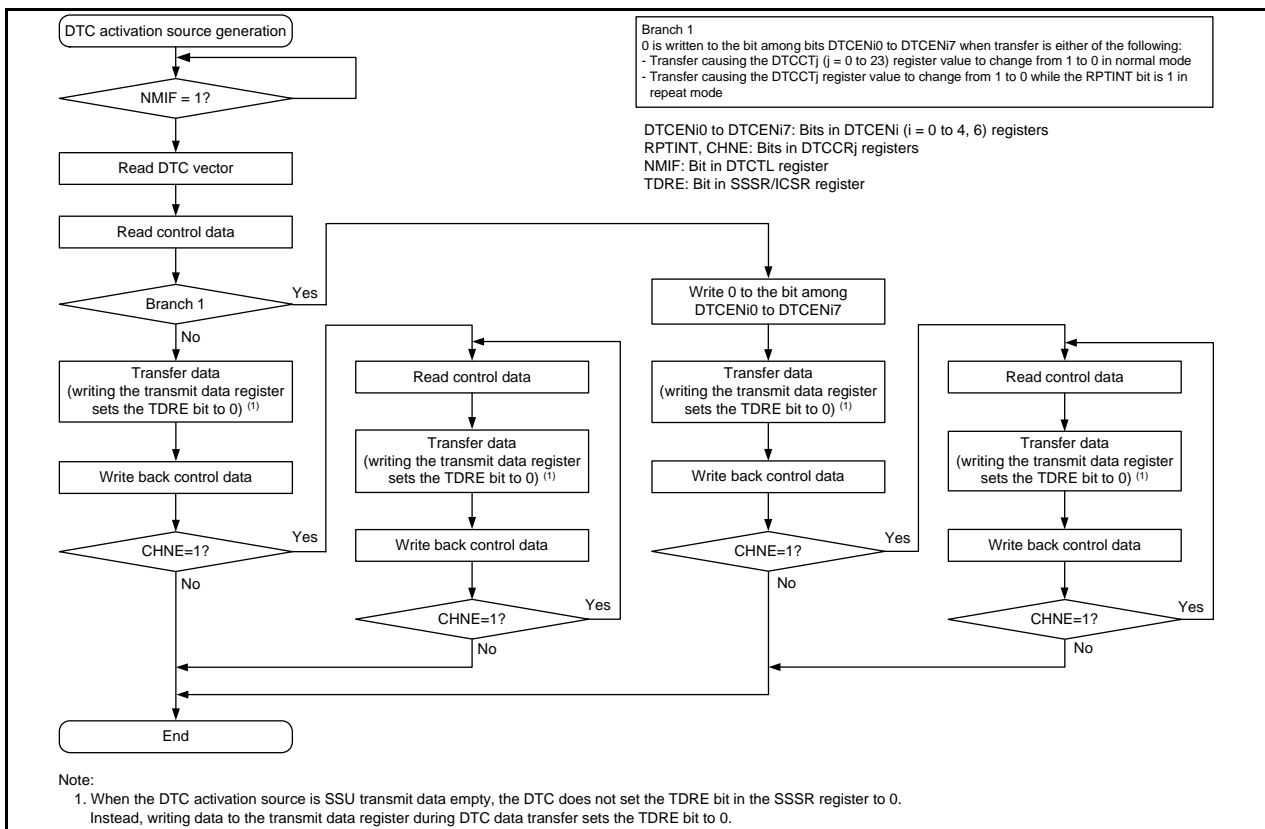

Figure 15.6 DTC Internal Operation Flowchart When DTC Activation Source is SSU Transmit Data Empty

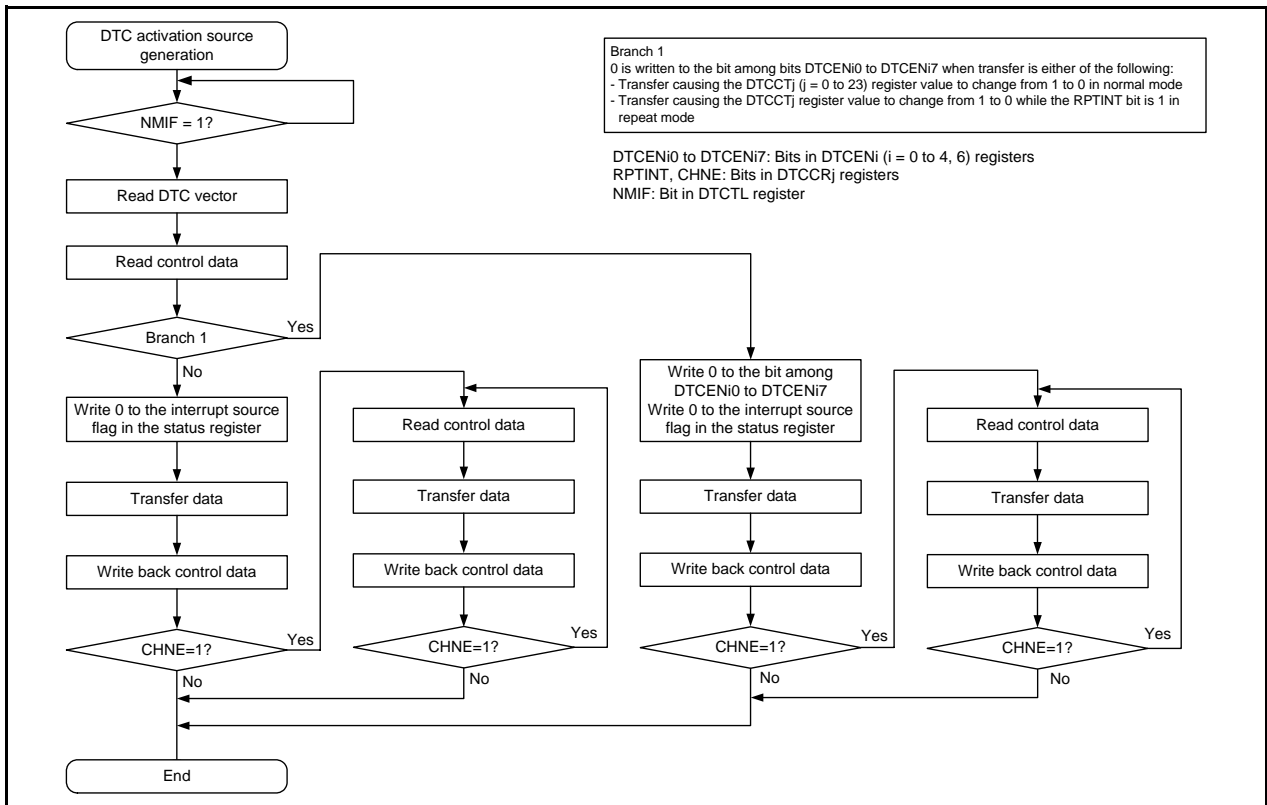

Figure 15.7 DTC Internal Operation Flowchart When DTC Activation Source is Flash ready status

15.3.4 Normal Mode

One to 256 bytes of data are transferred by one activation. The number of transfer times can be 1 to 256. When the data transfer causing the DTCCTj (j = 0 to 23) register value to change to 0 is performed, an interrupt request for the CPU is generated during DTC operation.

Table 15.6 shows Register Functions in Normal Mode.

Figure 15.8 shows Data Transfers in Normal Mode.

Table 15.6 Register Functions in Normal Mode

Register	Symbol	Function
DTC block size register j	DTBLSj	Size of the data block to be transferred by one activation
DTC transfer count register j	DTCCTj	Number of times of data transfers
DTC transfer count reload register j	DTRLDj	Not used
DTC source address register j	DTSARj	Data transfer source address
DTC destination address register j	DTDARj	Data transfer destination address

j = 0 to 23

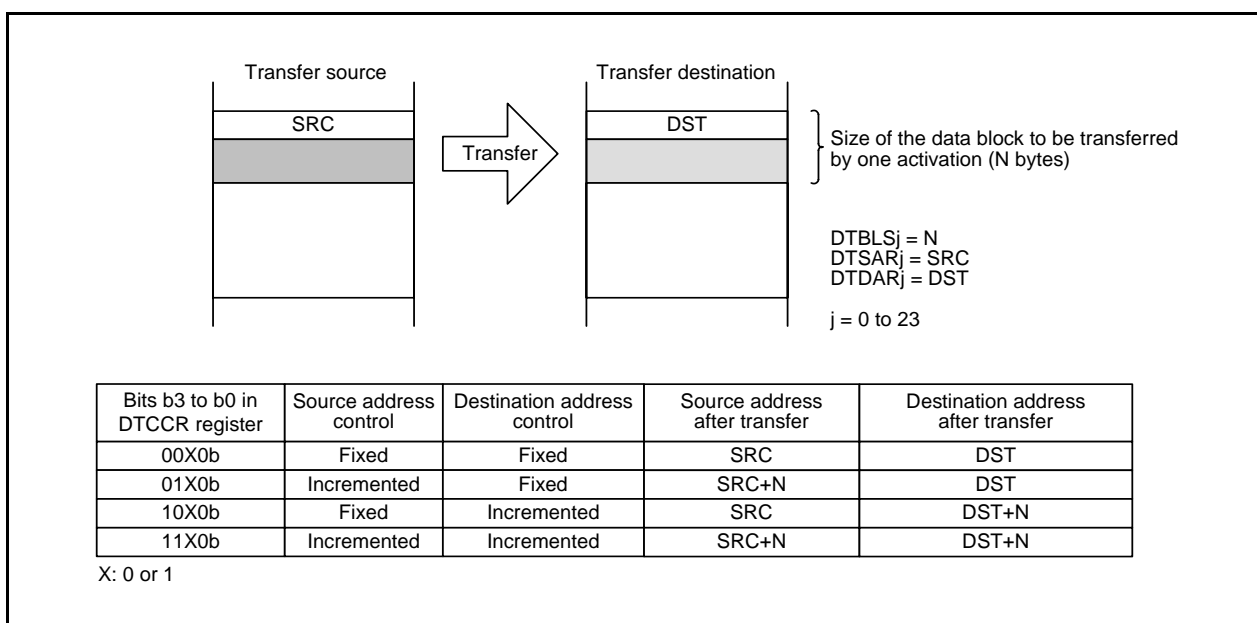

Figure 15.8 Data Transfers in Normal Mode

15.3.5 Repeat Mode

One to 255 bytes of data are transferred by one activation. Either of the transfer source or destination should be specified as the repeat area. The number of transfer times can be 1 to 255. On completion of the specified number of transfer times, the DTCCT_j (i = 0 to 23) register and the address specified for the repeat area are initialized to continue transfers. When the data transfer causing the DTCCT_j register value to change to 0 is performed while the RPTINT bit in the DTCCR_j register is 1 (interrupt generation enabled), an interrupt request for the CPU is generated during DTC operation.

The lower 8 bits of the initial value for the repeat area address must be 00h. The size of data to be transferred must be set to 255 bytes or less before the specified number of transfer times is completed.

Table 15.7 shows Register Functions in Repeat Mode.

Figure 15.9 shows Data Transfers in Repeat Mode.

Table 15.7 Register Functions in Repeat Mode

Register	Symbol	Function
DTC block size register j	DTBLS _j	Size of the data block to be transferred by one activation
DTC transfer count register j	DTCCT _j	Number of times of data transfers
DTC transfer count reload register j	DTRLD _j	This register value is reloaded to the DTCCT register. (Data transfer count is initialized.)
DTC source address register j	DTSAR _j	Data transfer source address
DTC destination address register j	DTDAR _j	Data transfer destination address

j = 0 to 23

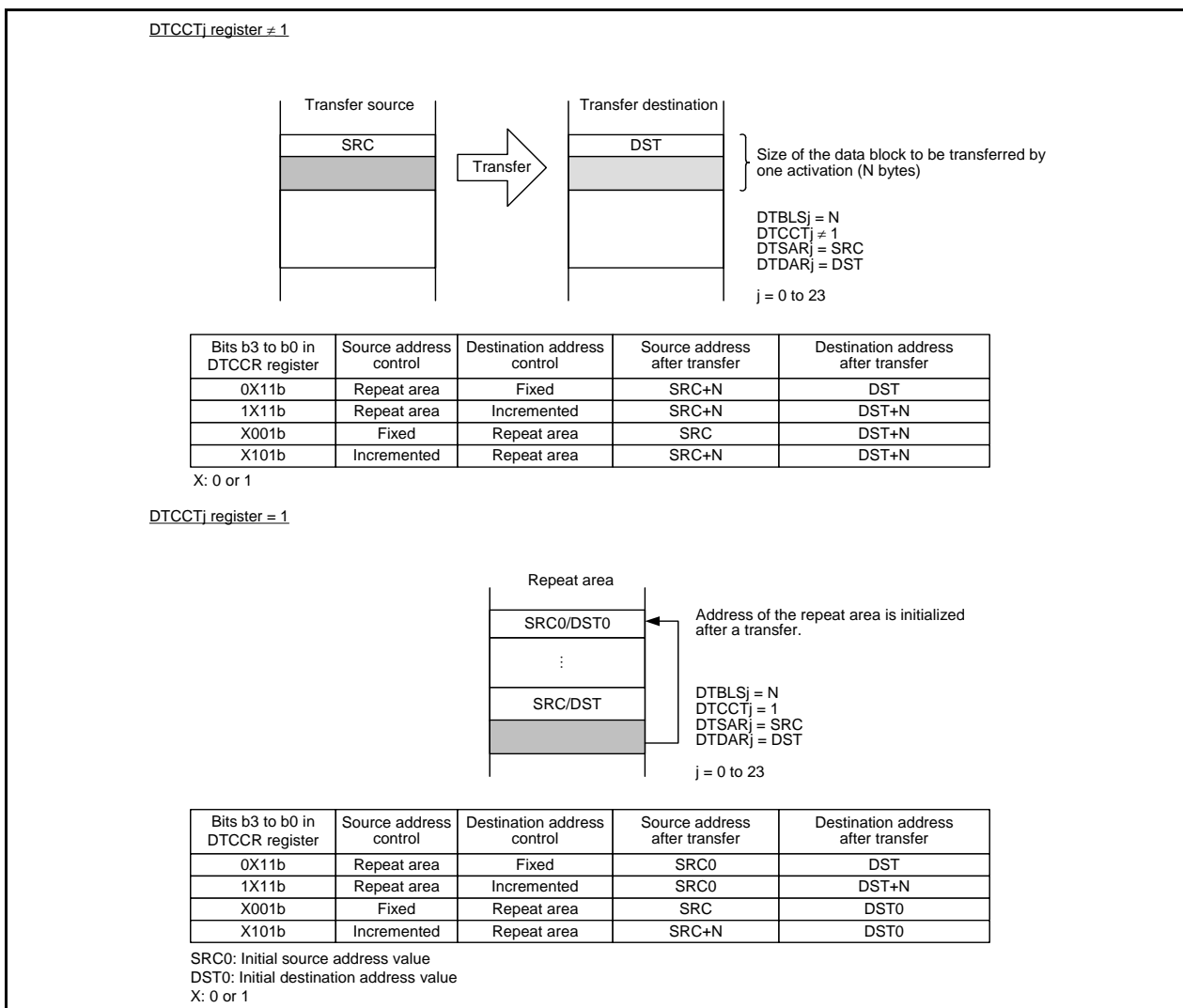

Figure 15.9 Data Transfers in Repeat Mode

15.3.6 Chain Transfers

When the CHNE bit in the DTCCRj (j = 0 to 22) register is 1 (chain transfers enabled), multiple data transfers can be continuously performed by one activation source. Figure 15.10 shows a Flow of Chain Transfers.

When the DTC is activated, one control data is selected according to the data read from the DTC vector address corresponding to the activation source, and the selected control data is read from the DTC control data area. When the CHNE bit for the control data is 1 (chain transfers enabled), the next control data immediately following the current control data is read and transferred after the current transfer is completed. This operation is repeated until the data transfer with the control data for which the CHNE bit is 0 (chain transfers disabled) is completed.

Set the CHNE bit in the DTCCR23 register to 0 (chain transfers disabled).

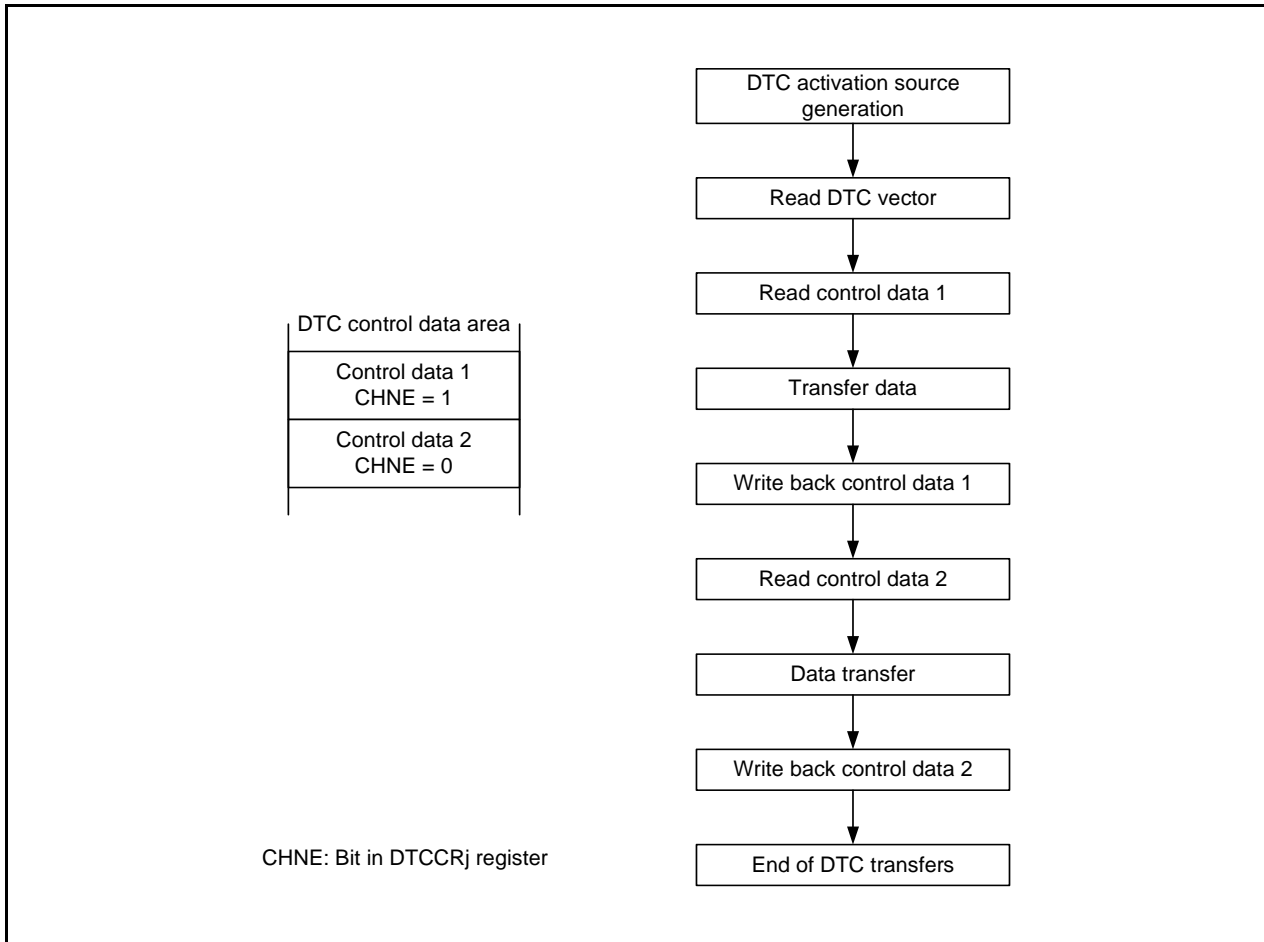

Figure 15.10 Flow of Chain Transfers

15.3.7 Interrupt Sources

When the data transfer causing the DTCCTj (j = 0 to 23) register value to change to 0 is performed in normal mode, and when the data transfer causing the DTCCTj register value to change to 0 is performed while the RPTINT bit in the DTCCRj register is 1 (interrupt generation enabled) in repeat mode, the interrupt request corresponding to the activation source is generated for the CPU during DTC operation. However, no interrupt request is generated for the CPU when the activation source is SSU transmit data empty or flash ready status.

Interrupt requests for the CPU are affected by the I flag or interrupt control register. In chain transfers, whether the interrupt request is generated or not is determined either by the number of transfer times specified for the first type of the transfer or the RPTINT bit. When an interrupt request is generated for the CPU, the bit among bits DTCENi0 to DTCENi7 in the DTCENi (i = 0 to 4, 6) registers corresponding to the activation source are set to 0 (activation disabled).

15.3.8 Operation Timings

The DTC requires five clock cycles to read control data allocated in the DTC control data area. The number of clock cycles required to write back control data differs depending on the control data settings.

Figure 15.11 shows an Example of DTC Operation Timings and Figure 15.12 shows an Example of DTC Operation Timings in Chain Transfers.

Table 15.8 shows the Specifications of Control Data Write-Back Operation.

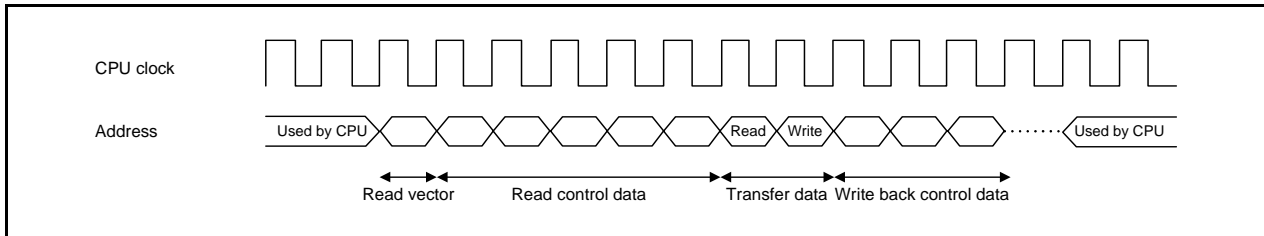

Figure 15.11 Example of DTC Operation Timings

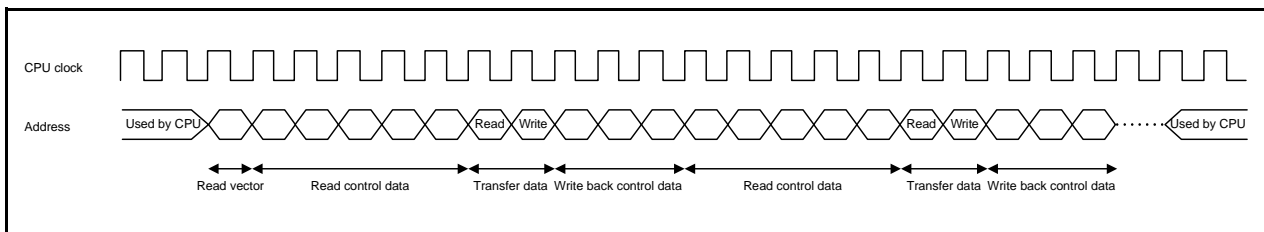

Figure 15.12 Example of DTC Operation Timings in Chain Transfers

Table 15.8 Specifications of Control Data Write-Back Operation

Bits b3 to b0 in DTCCR Register	Operating Mode	Address Control		Control Data to be Written Back				Number of Clock Cycles
		Source	Destination	DTCCT _j Register	DTRL _{Dj} Register	DTSAR _j Register	DTDAR _j Register	
00X0b	Normal mode	Fixed	Fixed	Written back	Written back	Not written back	Not written back	1
01X0b		Incremented	Fixed	Written back	Written back	Written back	Not written back	2
10X0b		Fixed	Incremented	Written back	Written back	Not written back	Written back	2
11X0b		Incremented	Incremented	Written back	Written back	Written back	Written back	3
0X11b	Repeat mode	Repeat area	Fixed	Written back	Written back	Written back	Not written back	2
1X11b			Incremented	Written back	Written back	Written back	Written back	3
X001b		Fixed	Repeat area	Written back	Written back	Not written back	Written back	2
X101b				Incremented	Written back	Written back	Written back	Written back

j = 0 to 23

X: 0 or 1

The specifications for writing back control data in chained transfer operations depend on either normal mode or repeat mode as listed in Table 15.8 for each activation source, according to the operating mode set for each activation source.

15.3.9 Number of DTC Execution Cycles

Table 15.9 shows the Operations Following DTC Activation and Required Number of Cycles for each operation.

Table 15.10 shows the Number of Clock Cycles Required for Data Transfers.

Table 15.9 Operations Following DTC Activation and Required Number of Cycles

Vector Read	Control Data		Data Read	Data Write	Internal Operation
	Read	Write-back			
1	5	(Note 2)	(Note 1)	(Note 1)	1

Notes:

1. For the number of clock cycles required for data read/write, refer to **Table 15.10 Number of Clock Cycles Required for Data Transfers**.
2. For the number of clock cycles required for control data write-back, refer to **Table 15.8 Specifications of Control Data Write-Back Operation**.

Data is transferred as described below, when the DTBLS_j (j = 0 to 23) register = N,

(1) When N = 2n (even), two-byte transfers are performed n times.

(2) When N = 2n + 1 (odd), two-byte transfers are performed n times followed by one time of one-byte transfer.

Table 15.10 Number of Clock Cycles Required for Data Transfers

Operation	Unit of Transfers	Internal RAM (During DTC Transfers)		Internal ROM (Program ROM)	Internal ROM (Data flash)	SFR (Word Access)		SFR (Byte Access)	SFR (DTC control data area)	
		Even Address	Odd Address			Even Address	Odd Address		Even Address	Odd Address
		Data read	1-byte SK1			1			1	2
	2-byte SK2	1	2	2	4	2	4	4	1	2
Data write	1-byte SL1	1		—	—	2		2	1	
	2-byte SL2	1	2	—	—	2	4	4	1	2

From Tables 15.9 and 15.10, the total number of required execution cycles can be obtained by the following formula:

Number of required execution cycles = 1 + Σ [formula A] + 2

Σ : Sum of the cycles for the number of transfer times performed by one activation source ([the number of transfer times for which CHNE is set to 1] + 1)

(1) For N = 2n (even)

Formula A = J + n • SK2 + n • SL2

(2) For N = 2n+1 (odd)

Formula A = J + n • SK2 + 1 • SK1 + n • SL2 + 1 • SL1

J: Number of cycles required to read control data (5 cycles) + number of cycles required to write back control data

To read data from or write data to the register that to be accessed in 16-bit units, set an even value of 2 or greater to the DTBLS_j (j = 0 to 23) register.

The DTC performs accesses in 16-bit units.

15.3.10 DTC Activation Source Acknowledgement and Interrupt Source Flags

15.3.10.1 Interrupt Sources Except for Flash Memory, Timer RC, Timer RD, and Synchronous Serial Communication Unit (SSU)

When the DTC activation source is an interrupt source except for the flash memory, timer RC, timer RD, or the synchronous serial communication unit, the same DTC activation source cannot be acknowledged for 8 to 12 cycles of the CPU clock after the interrupt source is generated. If an interrupt source is generated when a software command is executed, the same DTC activation source cannot be acknowledged for 9 to 16 cycles of the CPU clock. If a DTC activation source is generated during DTC operation and acknowledged, the same DTC activation source cannot be acknowledged for 8 to 12 cycles of the CPU clock on completion of the DTC transfer immediately before the DTC is activated by the source. When a software command is executed on completion of the DTC transfer immediately before the DTC is activated, the same DTC activation source cannot be acknowledged for 16 cycles of the CPU clock.

15.3.10.2 Flash Memory

When the DTC activation source is flash ready status, even if a flash ready status interrupt request is generated, it is not acknowledged as the DTC activation source after the RDYSTI bit in the FST register is set to 1 (flash ready status interrupt request) and before the DTC sets the RDYSTI bit to 0 (no flash ready status interrupt request). If a flash ready status interrupt request is generated after the DTC sets the RDYSTI bit to 0, the DTC acknowledges it as the activation source. 8 to 12 cycles of the CPU clock are required after the RDYSTI bit is set to 1 and before the DTC sets the interrupt request flag to 0. If a flash ready status interrupt is generated when a software command is executed, 9 to 16 cycles of the CPU clock are required before the DTC sets the interrupt source flag to 0. If a flash ready status interrupt request is generated during DTC operation and acknowledged as the DTC activation source, the RDYSTI bit is set to 0 after 8 to 12 cycles of the CPU clock on completion of the DTC transfer immediately before the DTC is activated by the source. When a software command is executed on completion of the DTC transfer immediately before the DTC is activated, the RDYSTI bit is set to 0 after 16 cycles of the CPU clock.

15.3.10.3 Timer RC, Timer RD

When the DTC activation source is an interrupt source for timer RC or timer RD, even if an input capture/compare match in individual timers occurs, it is not acknowledged as the DTC activation source after the interrupt source flag is set to 1 and before the DTC sets the flag to 0. If an input capture/compare match occurs after the DTC sets the interrupt source flag to 0, the DTC acknowledges it as the activation source. 8 to 12 cycles of the CPU clock plus 0.5 to 1.5 cycles of the timer operating clock are required after the interrupt source flag is set to 1 and before the DTC sets the flag to 0. If the interrupt request flag is set to 1 when a software command is executed, 9 to 16 cycles of the CPU clock plus 0.5 to 1.5 cycles of the timer operating clock are required before the DTC sets the interrupt source flag to 0. If individual DTC activation sources are generated for timer RC and timer RD during DTC operation and acknowledged, the interrupt source flag is set to 0 after 8 to 12 cycles of the CPU clock plus 0.5 to 1.5 cycles of the timer operating clock on completion of the DTC transfer immediately before the DTC is activated by the source. When a software command is executed on completion of the DTC transfer immediately before the DTC is activated, the interrupt source flag is set to 0 after 16 cycles of the CPU clock plus 0.5 to 1.5 cycles of the timer operating clock.

15.3.10.4 SSU Receive Data Full

When the DTC activation source is SSU receive data full, read the SSRDR register using a data transfer. The RDRF bit in the SSSR register is set to 0 (no data in SSRDR register) by reading the SSRDR register. If an interrupt source for receive data full is subsequently generated, the DTC acknowledges it as the activation source.

15.3.10.5 SSU Transmit Data Empty

When the DTC activation source is SSU transmit data empty, write to the SSTDR register using a data transfer. The TDRE bit in the SSSR register is set to 0 (data is not transferred from registers SSTDR to SSTRSR) by writing to the SSTDR register. If an interrupt source for transmit data empty is subsequently generated, the DTC acknowledges it as the activation source.

15.4 Notes on DTC

15.4.1 DTC activation source

- Do not generate any DTC activation sources before entering wait mode or during wait mode.
- Do not generate any DTC activation sources before entering stop mode or during stop mode.

15.4.2 DTCENi (i = 0 to 4, 6) Registers

- Modify bits DTCENi0 to DTCENi7 only while an interrupt request corresponding to the register is not generated.
- When the interrupt source flag in the status register for the peripheral function is 1, do not modify the corresponding activation source bit among bits DTCENi0 to DTCENi7.
- Do not access the DTCENi registers using DTC transfers.

15.4.3 Peripheral Modules

- Do not set the status register bit for the peripheral function to 0 using a DTC transfer.
- When the DTC activation source is SSU receive data full, read the SSRDR register using a DTC transfer. The RDRF bit in the SSSR register is set to 0 (no data in SSRDR) by reading the SSRDR register. However, the RDRF bit is not set to 0 by reading the SSRDR register when the DTC data transfer setting is either of the following:
 - Transfer causing the DTCCTj (j = 0 to 23) register value to change from 1 to 0 in normal mode
 - Transfer causing the DTCCRj register value to change from 1 to 0 while the RPTINT bit in the DTCCRj register is 1 (interrupt generation enabled) in repeat mode
- When the DTC activation source is SSU transmit data empty, write to the SSTDR register using a DTC transfer. The TDRE bit in the SSSR register is set to 0 (data is not transferred from registers SSTDR to SSTRSR) by writing to the SSTDR register.

15.4.4 Interrupt Request

No interrupt is generated for the CPU during DTC operation in any of the following cases:

- When the DTC activation source is SSU transmit data empty or flash ready status
- When performing the data transfer causing the DTCCTj (j = 0 to 23) register value to change to 0 in normal mode
- When performing the data transfer causing the DTCCRj register value to change to 0 while the RPTINT bit in the DTCCRj register is 1 (interrupt generation enabled) in repeat mode

15.4.5 DTC Activation

When the DTC is activated, operation may be shifted for one cycle before reading a vector.

15.4.6 DTC Chain Transfers

When performing chain transfers using several control data, the number of transfers set to the first control data is enabled and the number of transfers proceeded after the first control data is disabled.

Examples:

- When DTCCT0 = 5 and DTCCT1 = 10, chain transfers are performed as DTCCT0 = DTCCT1 = 5.
- When DTCCT0 = 10 and DTCCT1 = 5, chain transfers are performed as DTCCT0 = DTCCT1 = 10.
- When DTCCT0 = 10, DTCCT1 = 5, and DTCCT2 = 2, chain transfers are performed as DTCCT0 = DTCCT1 = DTCCT2 = 10.

16. General Overview of Timers

The MCU has two 8-bit timers with 8-bit prescalers, three 16-bit timers. The two 8-bit timers with 8-bit prescalers are timer RA and timer RB. These timers contain a reload register to store the default value of the counter. The one 16-bit timer is timer RC, and the two 16-bit timers are timer RD, and have input capture and output compare functions. All the timers operate independently.

Table 16.1 lists Functional Comparison of Timers.

Table 16.1 Functional Comparison of Timers

Item		Timer RA	Timer RB	Timer RC	Timer RD
Configuration		8-bit timer with 8-bit prescaler (with reload register)	8-bit timer with 8-bit prescaler (with reload register)	16-bit timer (with input capture and output compare)	16-bit timer × 2 (with input capture and output compare)
Count		Decrement	Decrement	Increment	Increment/Decrement
Count sources		<ul style="list-style-type: none"> • f1 • f2 • f8 • fOCO 	<ul style="list-style-type: none"> • f1 • f2 • f8 • Timer RA underflow 	<ul style="list-style-type: none"> • f1 • f2 • f4 • f8 • f32 • fOCO40M • fOCO-F • TRCCLK 	<ul style="list-style-type: none"> • f1 • f2 • f4 • f8 • f32 • fOCO40M • fOCO-F • TRDCLK
Function	Count of the internal count source	Timer mode	Timer mode	Timer mode (output compare function)	Timer mode (output compare function)
	Count of the external count source	Event counter mode	—	Timer mode (output compare function)	Timer mode (output compare function)
	External pulse width/period measurement	Pulse width measurement mode, pulse period measurement mode	—	Timer mode (input capture function; 4 pins)	Timer mode (input compare function; 2 × 4 pins)
	PWM output	Pulse output mode ⁽¹⁾ , Event counter mode ⁽¹⁾	Programmable waveform generation mode	Timer mode (output compare function; 4 pins) ⁽¹⁾ , PWM mode (3 pins), PWM2 mode (1 pin)	Timer mode (output compare function; 2 × 4 pins) ⁽¹⁾ , PWM mode (2 × 3 pins), PWM3 mode (1 × 2 pins)
	One-shot waveform output	—	Programmable one-shot generation mode, Programmable wait one-shot generation mode	PWM mode (3 pins)	PWM mode (2 × 3 pins)
	Three-phase waveforms output	—	—	—	Reset synchronous PWM mode (2 × 3 pins, Sawtooth wave modulation), Complementary PWM mode (2 × 3 pins, triangular wave modulation, dead time)
Input pin		TRAIO	INT0	INT0, TRCCLK, TRCTRG, TRCIOA, TRCIOB, TRCIOC, TRCIOD	INT0, TRDCLK, TRDIOA0, TRDIOA1, TRDIOB0, TRDIOB1, TRDIOC0, TRDIOC1, TRDIOD0, TRDIOD1
Output pin		TRAO, TRAIO	TRBO	TRCIOA, TRCIOB, TRCIOC, TRCIOD	TRDIOA0, TRDIOA1, TRDIOB0, TRDIOB1, TRDIOC0, TRDIOC1, TRDIOD0, TRDIOD1
Related interrupt		Timer RA interrupt	Timer RB interrupt, INT0 interrupt	Compare match/input capture A to D interrupt, Overflow interrupt, INT0 interrupt	Compare match/input capture A0 to D0 interrupt, Compare match/input capture A1 to D1 interrupt, Overflow interrupt, Underflow interrupt ⁽²⁾ , INT0 interrupt
Timer stop		Provided	Provided	Provided	Provided

Notes:

1. Rectangular waves are output in these modes. Since the waves are inverted at each overflow, the “H” and “L” level widths of the pulses are the same.
2. The underflow interrupt can be set to timer RD1.

17. Timer RA

Timer RA is an 8-bit timer with an 8-bit prescaler.

17.1 Overview

The prescaler and timer each consist of a reload register and counter. The reload register and counter are allocated at the same address, and can be accessed when accessing registers TRAPRE and TRA (refer to **Tables 17.2 to 17.6 the Specifications of Each Mode**).

The count source for timer RA is the operating clock that regulates the timing of timer operations such as counting and reloading.

Figure 17.1 shows a Timer RA Block Diagram. Table 17.1 lists Pin Configuration of Timer RA.

Timer RA contains the following five operating modes:

- **Timer mode:** The timer counts the internal count source.
- **Pulse output mode:** The timer counts the internal count source and outputs pulses which invert the polarity by underflow of the timer.
- **Event counter mode:** The timer counts external pulses.
- **Pulse width measurement mode:** The timer measures the pulse width of an external pulse.
- **Pulse period measurement mode:** The timer measures the pulse period of an external pulse.

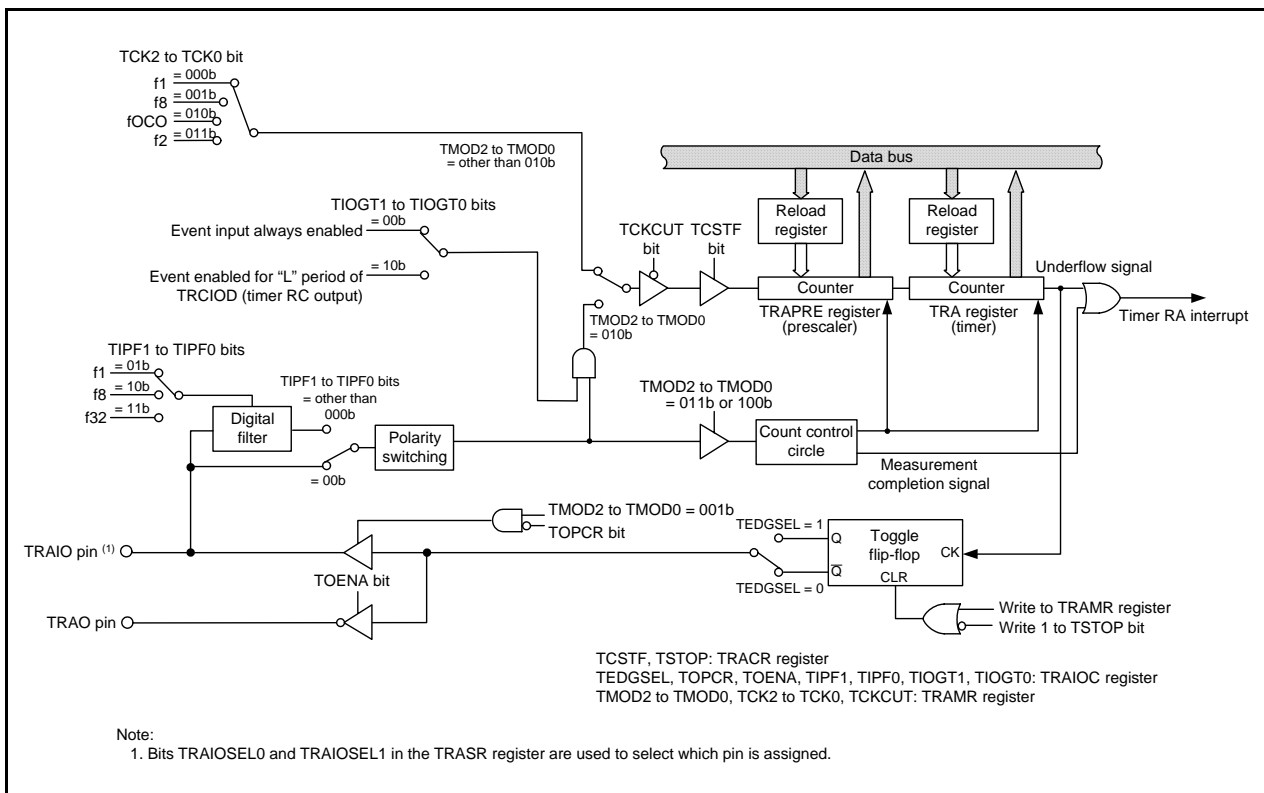

Figure 17.1 Timer RA Block Diagram

Table 17.1 Pin Configuration of Timer RA

Pin Name	Assigned Pin	I/O	Function
TRAIO	P1_5 or P1_7	I/O	Function differs according to the mode.
TRAO	P3_7	Output	Refer to descriptions of individual modes for details

17.2 Registers

17.2.1 Timer RA Control Register (TRACR)

Address 0100h

Bit	b7	b6	b5	b4	b3	b2	b1	b0
Symbol	—	—	TUNDF	TEDGF	—	TSTOP	TCSTF	TSTART
After Reset	0	0	0	0	0	0	0	0

Bit	Symbol	Bit Name	Function	R/W
b0	TSTART	Timer RA count start bit (1)	0: Count stops 1: Count starts	R/W
b1	TCSTF	Timer RA count status flag (1)	0: Count stops 1: During count	R
b2	TSTOP	Timer RA count forcible stop bit (2)	When this bit is set to 1, the count is forcibly stopped. When read, its content is 0.	R/W
b3	—	Nothing is assigned. If necessary, set to 0. When read, the content is 0.		—
b4	TEDGF	Active edge judgment flag (3, 4)	0: Active edge not received 1: Active edge received (end of measurement period)	R/W
b5	TUNDF	Timer RA underflow flag (3, 4)	0: No underflow 1: Underflow	R/W
b6	—	Nothing is assigned. If necessary, set to 0. When read, the content is 0.		—
b7	—			

Notes:

1. Refer to **17.8 Notes on Timer RA** for precautions regarding bits TSTART and TCSTF.
2. When the TSTOP bit is set to 1, bits TSTART and TCSTF and registers TRAPRE and TRA are set to the values after a reset.
3. Bits TEDGF and TUNDF can be set to 0 by writing 0 to these bits by a program. However, their value remains unchanged when 1 is written.
4. Set to 0 in timer mode, pulse output mode, or event count mode.

In pulse width measurement mode and pulse period measurement mode, use the MOV instruction to set the TRACR register. If it is necessary to avoid changing the values of bits TEDGF and TUNDF, write 1 to them.

17.2.2 Timer RA I/O Control Register (TRAIOC)

Address 0101h

Bit	b7	b6	b5	b4	b3	b2	b1	b0
Symbol	TIOGT1	TIOGT0	TIPF1	TIPF0	TIOSEL	TOENA	TOPCR	TEDGSEL
After Reset	0	0	0	0	0	0	0	0

Bit	Symbol	Bit Name	Function	R/W
b0	TEDGSEL	TRAI0 polarity switch bit	Function varies according to the operating mode.	R/W
b1	TOPCR	TRAI0 output control bit		R/W
b2	TOENA	TRAI0 output enable bit		R/W
b3	TIOSEL	Hardware LIN function select bit		R/W
b4	TIPF0	TRAI0 input filter select bit		R/W
b5	TIPF1			R/W
b6	TIOGT0	TRAI0 event input control bit		R/W
b7	TIOGT1			R/W

17.2.3 Timer RA Mode Register (TRAMR)

Address 0102h

Bit	b7	b6	b5	b4	b3	b2	b1	b0
Symbol	TCKCUT	TCK2	TCK1	TCK0	—	TMOD2	TMOD1	TMOD0
After Reset	0	0	0	0	0	0	0	0

Bit	Symbol	Bit Name	Function	R/W
b0	TMOD0	Timer RA operating mode select bit	b2 b1 b0 0 0 0: Timer mode 0 0 1: Pulse output mode 0 1 0: Event counter mode 0 1 1: Pulse width measurement mode 1 0 0: Pulse period measurement mode 1 0 1: Do not set. 1 1 0: Do not set. 1 1 1: Do not set.	R/W
b1	TMOD1			R/W
b2	TMOD2			R/W
b3	—			Nothing is assigned. If necessary, set to 0. When read, the content is 0.
b4	TCK0	Timer RA count source select bit	b6 b5 b4 0 0 0: f1 0 0 1: f8 0 1 0: fOCO 0 1 1: f2 1 0 0: Do not set. 1 0 1: Do not set. 1 1 0: Do not set. 1 1 1: Do not set.	R/W
b5	TCK1			R/W
b6	TCK2			R/W
b7	TCKCUT	Timer RA count source cutoff bit	0: Provides count source 1: Cuts off count source	R/W

When both the TSTART and TCSTF bits in the TRACR register are set to 0 (count stops), rewrite this register.

17.2.4 Timer RA Prescaler Register (TRAPRE)

Address 0103h

Bit	b7	b6	b5	b4	b3	b2	b1	b0
Symbol	—	—	—	—	—	—	—	—
After Reset	1	1	1	1	1	1	1	1 (Note 1)

Bit	Mode	Function	Setting Range	R/W
b7 to b0	Timer mode	Counts an internal count source	00h to FFh	R/W
	Pulse output mode		00h to FFh	R/W
	Event counter mode	Counts an external count source	00h to FFh	R/W
	Pulse width measurement mode	Measure pulse width of input pulses from external (counts internal count source)	00h to FFh	R/W
	Pulse period measurement mode	Measure pulse period of input pulses from external (counts internal count source)	00h to FFh	R/W

Note:

- When the TSTOP bit in the TRACR register is set to 1, the TRAPRE register is set to FFh.

17.2.5 Timer RA Register (TRA)

Address 0104h

Bit	b7	b6	b5	b4	b3	b2	b1	b0
Symbol	—	—	—	—	—	—	—	—
After Reset	1	1	1	1	1	1	1	1 (Note 1)

Bit	Mode	Function	Setting Range	R/W
b7 to b0	All modes	Counts on underflow of TRAPRE register	00h to FFh ⁽²⁾	R/W

Notes:

1. When the TSTOP bit in the TRACR register is set to 1, the TRAPRE register is set to FFh.
2. Do not set 00h to the TRA register in pulse width measurement mode and pulse period measurement mode.

17.2.6 Timer RA Pin Select Register (TRASR)

Address 0180h

Bit	b7	b6	b5	b4	b3	b2	b1	b0
Symbol	—	—	—	—	—	—	TRAIOSSEL1	TRAIOSSEL0
After Reset	0	0	0	0	0	0	0	0

Bit	Symbol	Bit Name	Function	R/W
b0	TRAIOSSEL0	TRAIO pin select bit	^{b1 b0} 0 0: TRAIIO pin not used 0 1: P1_7 assigned 1 0: P1_5 assigned 1 1: Do not set.	R/W
b1	TRAIOSSEL1			R/W
b2	—	Reserved bits	Set to 0.	R/W
b3	—			R/W
b4	—	Nothing is assigned. If necessary, set to 0. When read, the content is 0.		—
b5	—			
b6	—			
b7	—			

The TRASR register selects which pin is assigned to the timer RA I/O. To use the I/O pin for timer RA, set this register.

Set the TRASR register before setting the timer RA associated registers. Also, do not change the setting value in this register during timer RA operation.

17.3 Timer Mode

In this mode, the timer counts an internally generated count source (refer to **Table 17.2 Timer Mode Specifications**).

Table 17.2 Timer Mode Specifications

Item	Specification
Count sources	f1, f2, f8, fOCO
Count operations	<ul style="list-style-type: none"> Decrement When the timer underflows, the contents of the reload register are reloaded and the count is continued.
Divide ratio	$1/(n+1)(m+1)$ n: Value set in TRAPRE register, m: Value set in TRA register
Count start condition	1 (count starts) is written to the TSTART bit in the TRACR register.
Count stop conditions	<ul style="list-style-type: none"> 0 (count stops) is written to the TSTART bit in the TRACR register. 1 (count forcibly stops) is written to the TSTOP bit in the TRACR register.
Interrupt request generation timing	When timer RA underflows [timer RA interrupt].
TRAIO pin function	Programmable I/O port
TRAO pin function	Programmable I/O port
Read from timer	The count value can be read by reading registers TRA and TRAPRE.
Write to timer	<ul style="list-style-type: none"> When registers TRAPRE and TRA are written while the count is stopped, values are written to both the reload register and counter. When registers TRAPRE and TRA are written during the count, values are written to the reload register and counter (refer to 17.3.2 Timer Write Control during Count Operation).

17.3.1 Timer RA I/O Control Register (TRAIOC) in Timer Mode

Address 0101h

Bit	b7	b6	b5	b4	b3	b2	b1	b0
Symbol	TIOGT1	TIOGT0	TIPF1	TIPF0	TIOSEL	TOENA	TOPCR	TEDGSEL
After Reset	0	0	0	0	0	0	0	0

Bit	Symbol	Bit Name	Function	R/W
b0	TEDGSEL	TRAIO polarity switch bit	Set to 0 in timer mode.	R/W
b1	TOPCR	TRAIO output control bit		R/W
b2	TOENA	TRAO output enable bit		R/W
b3	TIOSEL	Hardware LIN function select bit	Set to 0. However, set to 1 when the hardware LIN function is used.	R/W
b4	TIPF0	TRAIO input filter select bit	Set to 0 in timer mode.	R/W
b5	TIPF1			R/W
b6	TIOGT0	TRAIO event input control bit		R/W
b7	TIOGT1			R/W

17.3.2 Timer Write Control during Count Operation

Timer RA has a prescaler and a timer (which counts the prescaler underflows). The prescaler and timer each consist of a reload register and a counter. When writing to the prescaler or timer, values are written to both the reload register and counter.

However, values are transferred from the reload register to the counter of the prescaler in synchronization with the count source. In addition, values are transferred from the reload register to the counter of the timer in synchronization with prescaler underflows. Therefore, if the prescaler or timer is written to when count operation is in progress, the counter value is not updated immediately after the WRITE instruction is executed. Figure 17.2 shows an Operating Example of Timer RA when Counter Value is Rewritten during Count Operation.

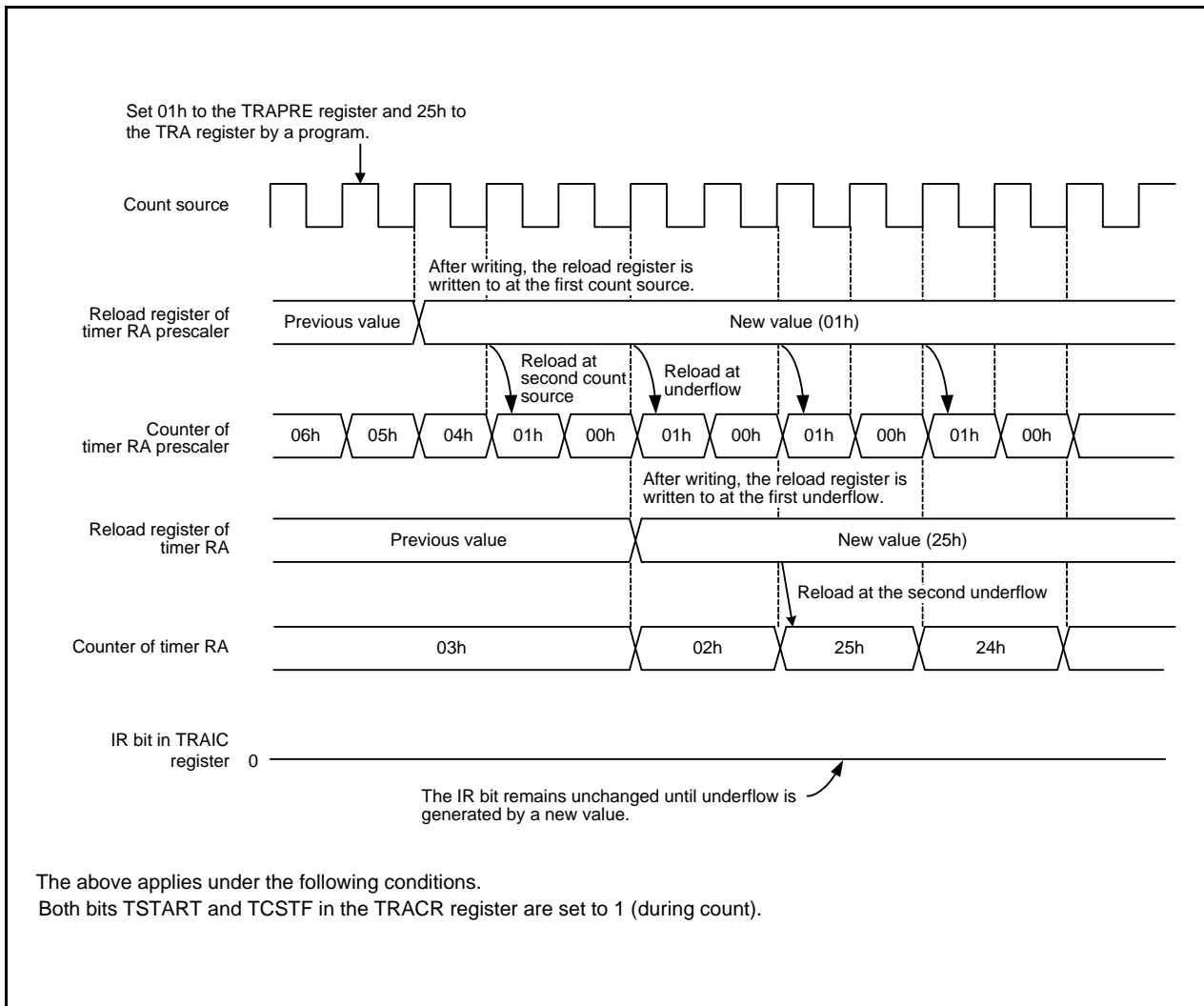

Figure 17.2 Operating Example of Timer RA when Counter Value is Rewritten during Count Operation

17.4 Pulse Output Mode

In pulse output mode, the internally generated count source is counted, and a pulse with inverted polarity is output from the TRAI0 pin each time the timer underflows (refer to **Table 17.3 Pulse Output Mode Specifications**).

Table 17.3 Pulse Output Mode Specifications

Item	Specification
Count sources	f1, f2, f8, fOCO
Count operations	<ul style="list-style-type: none"> • Decrement • When the timer underflows, the contents in the reload register is reloaded and the count is continued.
Divide ratio	$1/(n+1)(m+1)$ n: Value set in TRAPRE register, m: Value set in TRA register
Count start condition	1 (count starts) is written to the TSTART bit in the TRACR register.
Count stop conditions	<ul style="list-style-type: none"> • 0 (count stops) is written to the TSTART bit in the TRACR register. • 1 (count forcibly stops) is written to the TSTOP bit in the TRACR register.
Interrupt request generation timing	When timer RA underflows [timer RA interrupt].
TRAI0 pin function	Pulse output, programmable output port
TRAO pin function	Programmable I/O port or inverted output of TRAI0
Read from timer	The count value can be read by reading registers TRA and TRAPRE.
Write to timer	<ul style="list-style-type: none"> • When registers TRAPRE and TRA are written while the count is stopped, values are written to both the reload register and counter. • When registers TRAPRE and TRA are written during the count, values are written to the reload register and counter (refer to 17.3.2 Timer Write Control during Count Operation).
Selectable functions	<ul style="list-style-type: none"> • TRAI0 signal polarity switch function The level when the pulse output starts is selected by the TEDGSEL bit in the TRAI0C register. ⁽¹⁾ • TRAO output function Pulses inverted from the TRAI0 output polarity can be output from the TRAO pin (selectable by the TOENA bit in the TRAI0C register). • Pulse output stop function Output from the TRAI0 pin is stopped by the TOPCR bit in the TRAI0C register. • TRAI0 pin select function P1_5 or P1_7 is selected by bits TRAI0SEL0 to TRAI0SEL1 in the TRASR register.

Note:

1. The level of the output pulse becomes the level when the pulse output starts when the TRAMR register is written to.

17.4.1 Timer RA I/O Control Register (TRAIOC) in Pulse Output Mode

Address 0101h

Bit	b7	b6	b5	b4	b3	b2	b1	b0
Symbol	TIOGT1	TIOGT0	TIPF1	TIPF0	TIOSEL	TOENA	TOPCR	TEDGSEL
After Reset	0	0	0	0	0	0	0	0

Bit	Symbol	Bit Name	Function	R/W
b0	TEDGSEL	TRAIO polarity switch bit	0: TRAIO output starts at "H" 1: TRAIO output starts at "L"	R/W
b1	TOPCR	TRAIO output control bit ⁽¹⁾	0: TRAIO output 1: TRAIO output disabled	R/W
b2	TOENA	TRAIO output enable bit	0: TRAIO output disabled 1: TRAIO output (inverted TRAIO output from the port)	R/W
b3	TIOSEL	Hardware LIN function select bit	Set to 0.	R/W
b4	TIPF0	TRAIO input filter select bit	Set to 0 in pulse output mode.	R/W
b5	TIPF1			R/W
b6	TIOGT0			R/W
b7	TIOGT1	TRAIO event input control bit		R/W

Note:

1. Bits TRAIOSSEL0 and TRAIOSSEL1 in the TRASR register are used to select either P1_5 or P1_7 to be assigned to the TRAIO pin.

17.5 Event Counter Mode

In event counter mode, external signal inputs to the TRAI0 pin are counted (refer to **Table 17.4 Event Counter Mode Specifications**).

Table 17.4 Event Counter Mode Specifications

Item	Specification
Count source	External signal which is input to TRAI0 pin (active edge selectable by a program)
Count operations	<ul style="list-style-type: none"> • Decrement • When the timer underflows, the contents of the reload register are reloaded and the count is continued.
Divide ratio	$1/(n+1)(m+1)$ n: setting value of TRAPRE register, m: setting value of TRA register
Count start condition	1 (count starts) is written to the TSTART bit in the TRACR register.
Count stop conditions	<ul style="list-style-type: none"> • 0 (count stops) is written to the TSTART bit in the TRACR register. • 1 (count forcibly stops) is written to the TSTOP bit in the TRACR register.
Interrupt request generation timing	When timer RA underflows [timer RA interrupt].
TRAI0 pin function	Count source input
TRAO pin function	Programmable I/O port or pulse output ⁽¹⁾
Read from timer	The count value can be read by reading registers TRA and TRAPRE.
Write to timer	<ul style="list-style-type: none"> • When registers TRAPRE and TRA are written while the count is stopped, values are written to both the reload register and counter. • When registers TRAPRE and TRA are written during the count, values are written to the reload register and counter (refer to 17.3.2 Timer Write Control during Count Operation).
Selectable functions	<ul style="list-style-type: none"> • TRAI0 input polarity switch function The active edge of the count source is selected by the TEDGSEL bit in the TRAI0C register. • Count source input pin select function P1_5 or P1_7 is selected by bits TRAI0SEL0 to TRAI0SEL1 in the TRASR register. • Pulse output function Pulses of inverted polarity can be output from the TRAO pin each time the timer underflows (selectable by the TOENA bit in the TRAI0C register). ⁽¹⁾ • Digital filter function Whether enabling or disabling the digital filter and the sampling frequency is selected by bits TIPF0 and TIPF1 in the TRAI0C register. • Event input control function The enabled period for the event input to the TRAI0 pin is selected by bits TIOGT0 and TIOGT1 in the TRAI0C register.

Note:

1. The level of the output pulse becomes the level when the pulse output starts when the TRAMR register is written to.

17.5.1 Timer RA I/O Control Register (TRAIOC) in Event Counter Mode

Address 0101h

Bit	b7	b6	b5	b4	b3	b2	b1	b0
Symbol	TIOGT1	TIOGT0	TIPF1	TIPF0	TIOSEL	TOENA	TOPCR	TEDGSEL
After Reset	0	0	0	0	0	0	0	0

Bit	Symbol	Bit Name	Function	R/W
b0	TEDGSEL	TRAIO polarity switch bit	0: Starts counting at rising edge of the TRAIO input and TRAO starts output at "L" 1: Starts counting at falling edge of the TRAIO input and TRAO starts output at "H"	R/W
b1	TOPCR	TRAIO output control bit	Set to 0 in event counter mode.	R/W
b2	TOENA	TRAIO output enable bit	0: TRAO output disabled 1: TRAO output	R/W
b3	TIOSEL	Hardware LIN function select bit	Set to 0.	R/W
b4	TIPF0	TRAIO input filter select bit ⁽¹⁾	^{b5 b4} 0 0: No filter 0 1: Filter with f1 sampling 1 0: Filter with f8 sampling 1 1: Filter with f32 sampling	R/W
b5	TIPF1			R/W
b6	TIOGT0	TRAIO event input control bit	^{b7 b6} 0 0: Event input always enabled 0 1: Do not set. 1 0: Event input enabled for "L" period of TRCIOD (timer RC output) 1 1: Do not set.	R/W
b7	TIOGT1			R/W

Note:

1. When the same value from the TRAIO pin is sampled three times continuously, the input is determined.

17.6 Pulse Width Measurement Mode

In pulse width measurement mode, the pulse width of an external signal input to the TRAIIO pin is measured (refer to **Table 17.5 Pulse Width Measurement Mode Specifications**).

Figure 17.3 shows an Operating Example of Pulse Width Measurement Mode.

Table 17.5 Pulse Width Measurement Mode Specifications

Item	Specification
Count sources	f1, f2, f8, fOCO
Count operations	<ul style="list-style-type: none"> • Decrement • Continuously counts the selected signal only when measurement pulse is “H” level, or conversely only “L” level. • When the timer underflows, the contents of the reload register are reloaded and the count is continued.
Count start condition	1 (count starts) is written to the TSTART bit in the TRACR register.
Count stop conditions	<ul style="list-style-type: none"> • 0 (count stops) is written to the TSTART bit in the TRACR register. • 1 (count forcibly stops) is written to the TSTOP bit in the TRACR register.
Interrupt request generation timing	<ul style="list-style-type: none"> • When timer RA underflows [timer RA interrupt]. • Rising or falling of the TRAIIO input (end of measurement period) [timer RA interrupt]
TRAIIO pin function	Measured pulse input
TRAO pin function	Programmable I/O port
Read from timer	The count value can be read by reading registers TRA and TRAPRE.
Write to timer	<ul style="list-style-type: none"> • When registers TRAPRE and TRA are written while the count is stopped, values are written to both the reload register and counter. • When registers TRAPRE and TRA are written during the count, values are written to the reload register and counter (refer to 17.3.2 Timer Write Control during Count Operation).
Selectable functions	<ul style="list-style-type: none"> • Measurement level setting The “H” level or “L” level period is selected by the TEDGSEL bit in the TRAIIOC register. • Measured pulse input pin select function P1_5 or P1_7 is selected by bits TRAIIOSEL0 to TRAIIOSEL1 in the TRASR register. • Digital filter function Whether enabling or disabling the digital filter and the sampling frequency is selected by bits TIPF0 and TIPF1 in the TRAIIOC register.

17.6.1 Timer RA I/O Control Register (TRAIOC) in Pulse Width Measurement Mode

Address 0101h

Bit	b7	b6	b5	b4	b3	b2	b1	b0
Symbol	TIOGT1	TIOGT0	TIPF1	TIPF0	TIOSEL	TOENA	TOPCR	TEDGSEL
After Reset	0	0	0	0	0	0	0	0

Bit	Symbol	Bit Name	Function	R/W
b0	TEDGSEL	TRAIO polarity switch bit	0: TRAIO input starts at "L" 1: TRAIO input starts at "H"	R/W
b1	TOPCR	TRAIO output control bit	Set to 0 in pulse width measurement mode.	R/W
b2	TOENA	TRAIO output enable bit		R/W
b3	TIOSEL	Hardware LIN function select bit	Set to 0. However, set to 1 when the hardware LIN function is used.	R/W
b4	TIPF0	TRAIO input filter select bit ⁽¹⁾	^{b5 b4} 0 0: No filter 0 1: Filter with f1 sampling 1 0: Filter with f8 sampling 1 1: Filter with f32 sampling	R/W
b5	TIPF1			R/W
b6	TIOGT0	TRAIO event input control bit	Set to 0 in pulse width measurement mode.	R/W
b7	TIOGT1			R/W

Note:

1. When the same value from the TRAIO pin is sampled three times continuously, the input is determined.

17.6.2 Operating Example

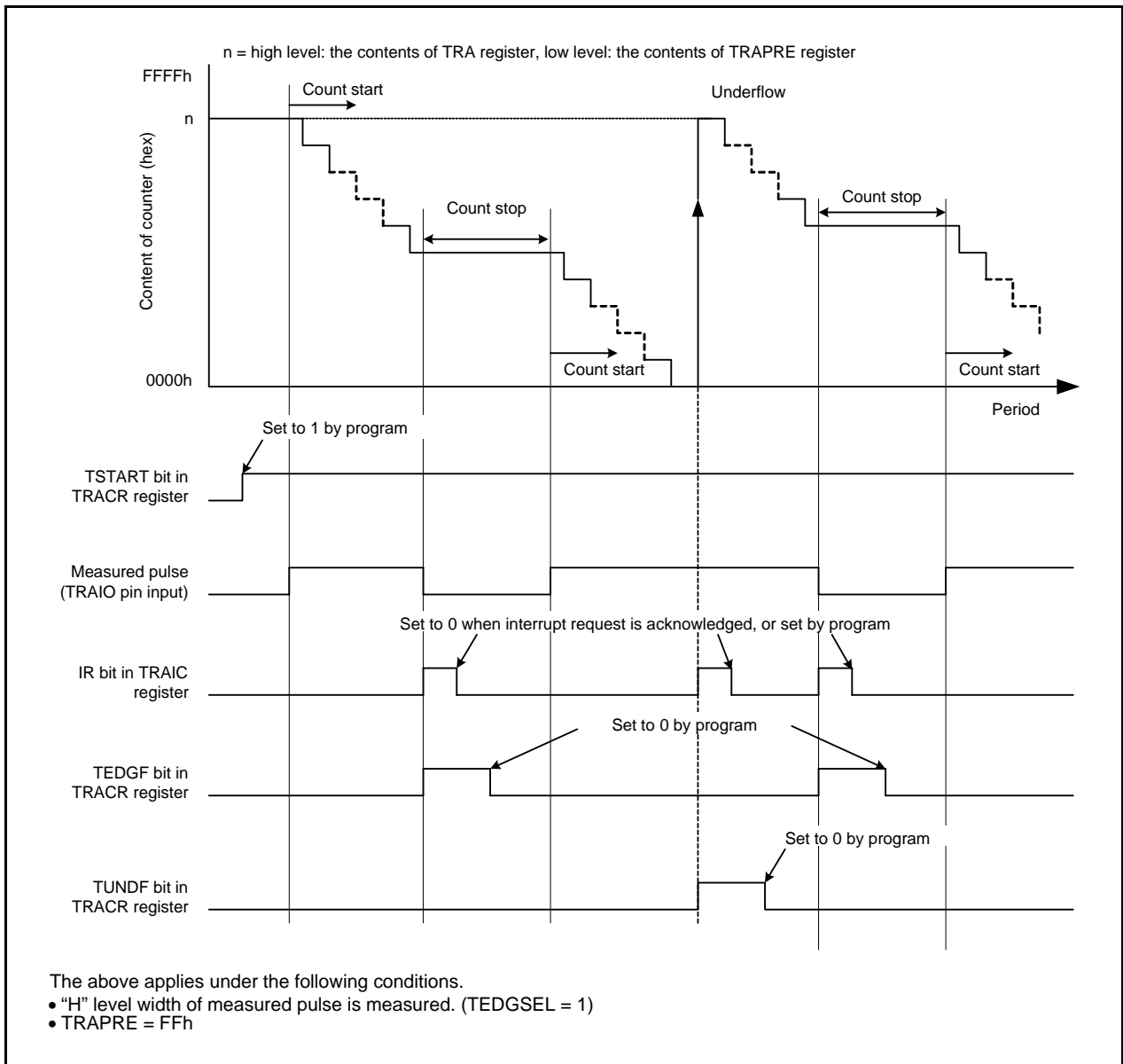

Figure 17.3 Operating Example of Pulse Width Measurement Mode

17.7 Pulse Period Measurement Mode

In pulse period measurement mode, the pulse period of an external signal input to the TRAI0 pin is measured (refer to **Table 17.6 Pulse Period Measurement Mode Specifications**).

Figure 17.4 shows an Operating Example of Pulse Period Measurement Mode.

Table 17.6 Pulse Period Measurement Mode Specifications

Item	Specification
Count sources	f1, f2, f8, fOCO
Count operations	<ul style="list-style-type: none"> Decrement After the active edge of the measured pulse is input, the contents of the read-out buffer are retained at the first underflow of timer RA prescaler. Then timer RA reloads the contents in the reload register at the second underflow of timer RA prescaler and continues counting.
Count start condition	1 (count starts) is written to the TSTART bit in the TRACR register.
Count stop conditions	<ul style="list-style-type: none"> 0 (count stops) is written to TSTART bit in the TRACR register. 1 (count forcibly stops) is written to the TSTOP bit in the TRACR register.
Interrupt request generation timing	<ul style="list-style-type: none"> When timer RA underflows or reloads [timer RA interrupt]. Rising or falling of the TRAI0 input (end of measurement period) [timer RA interrupt]
TRAI0 pin function	Measured pulse input (1)
TRAO pin function	Programmable I/O port
Read from timer	The count value can be read by reading registers TRA and TRAPRE.
Write to timer	<ul style="list-style-type: none"> When registers TRAPRE and TRA are written while the count is stopped, values are written to both the reload register and counter. When registers TRAPRE and TRA are written during the count, values are written to the reload register and counter (refer to 17.3.2 Timer Write Control during Count Operation).
Selectable functions	<ul style="list-style-type: none"> Measurement period selection The measurement period of the input pulse is selected by the TEDGSEL in the TRAI0C register. Measured pulse input pin select function P1_5 or P1_7 is selected by bits TRAI0SEL0 to TRAI0SEL1 in the TRASR register. Digital filter function Whether enabling or disabling the digital filter and the sampling frequency is selected by bits TIPF0 and TIPF1 in the TRAI0C register.

Note:

- Input a pulse with a period longer than twice the timer RA prescaler period. Input a pulse with a longer "H" and "L" width than the timer RA prescaler period. If a pulse with a shorter period is input to the TRAI0 pin, the input may be ignored.

17.7.1 Timer RA I/O Control Register (TRAIOC) in Pulse Period Measurement Mode

Address 0101h

Bit	b7	b6	b5	b4	b3	b2	b1	b0
Symbol	TIOGT1	TIOGT0	TIPF1	TIPF0	TIOSEL	TOENA	TOPCR	TEDGSEL
After Reset	0	0	0	0	0	0	0	0

Bit	Symbol	Bit Name	Function	R/W
b0	TEDGSEL	TRAIO polarity switch bit	0: Measures measurement pulse from one rising edge to next rising edge 1: Measures measurement pulse from one falling edge to next falling edge	R/W
b1	TOPCR	TRAIO output control bit	Set to 0 in pulse period measurement mode.	R/W
b2	TOENA	TRAIO output enable bit		R/W
b3	TIOSEL	Hardware LIN function select bit	Set to 0.	R/W
b4	TIPF0	TRAIO input filter select bit (1)	b5 b4 0 0: No filter 0 1: Filter with f1 sampling 1 0: Filter with f8 sampling 1 1: Filter with f32 sampling	R/W
b5	TIPF1			R/W
b6	TIOGT0	TRAIO event input control bit	Set to 0 in pulse period measurement mode.	R/W
b7	TIOGT1			R/W

Note:

1. When the same value from the TRAIO pin is sampled three times continuously, the input is determined.

17.7.2 Operating Example

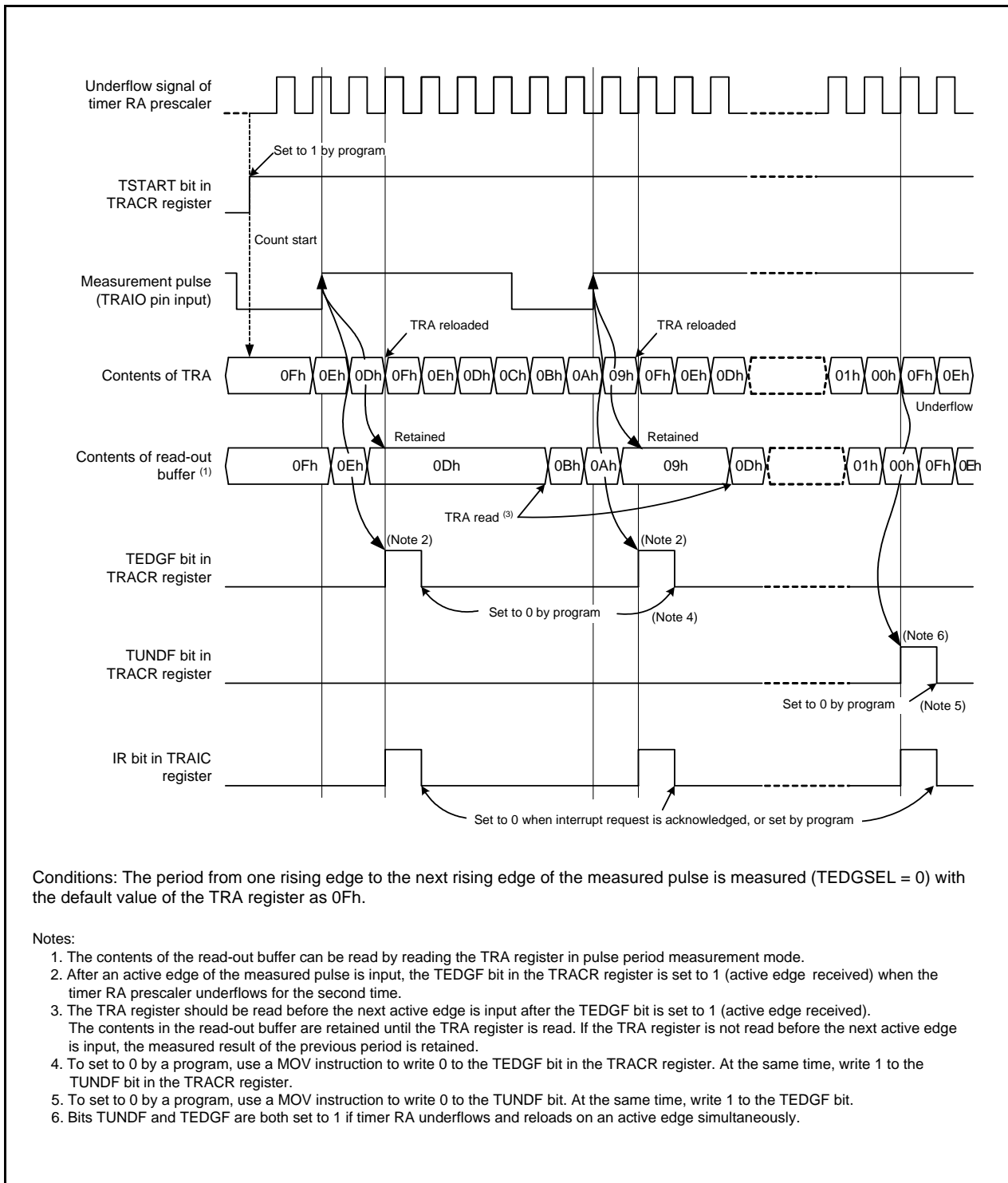

Figure 17.4 Operating Example of Pulse Period Measurement Mode

17.8 Notes on Timer RA

- Timer RA stops counting after a reset. Set the values in the timer RA and timer RA prescalers before the count starts.
- Even if the prescaler and timer RA are read out in 16-bit units, these registers are read 1 byte at a time by the MCU. Consequently, the timer value may be updated during the period when these two registers are being read.
- In pulse width measurement mode and pulse period measurement mode, bits TEDGF and TUNDF in the TRACR register can be set to 0 by writing 0 to these bits by a program. However, these bits remain unchanged if 1 is written. When using the READ-MODIFY-WRITE instruction for the TRACR register, the TEDGF or TUNDF bit may be set to 0 although these bits are set to 1 while the instruction is being executed. In this case, write 1 to the TEDGF or TUNDF bit which is not supposed to be set to 0 with the MOV instruction.
- When changing to pulse period measurement mode from another mode, the contents of bits TEDGF and TUNDF are undefined. Write 0 to bits TEDGF and TUNDF before the count starts.
- The TEDGF bit may be set to 1 by the first timer RA prescaler underflow generated after the count starts.
- When using the pulse period measurement mode, leave two or more periods of the timer RA prescaler immediately after the count starts, then set the TEDGF bit to 0.
- The TCSTF bit retains 0 (count stops) for 0 to 1 cycle of the count source after setting the TSTART bit to 1 (count starts) while the count is stopped.

Do not write to the TRACR register until the TCSTF bit is set to 1. Also, do not access other registers associated with timer RA ⁽¹⁾.

The TCSTF bit remains 1 for 0 to 1 cycle of the count source after setting the TSTART bit to 0 (count stops) while the count is in progress. Timer RA counting is stopped when the TCSTF bit is set to 0.

Do not write to the TRACR register until the TCSTF bit is set to 0. Also, do not access other registers associated with timer RA ⁽¹⁾.

Note:

1. Registers associated with timer RA: TRAIOC, TRAMR, TRAPRE, and TRA.

- When the TRAPRE register is continuously written during count operation (TCSTF bit is set to 1), allow three or more cycles of the count source clock for each write interval.
- When the TRA register is continuously written during count operation (TCSTF bit is set to 1), allow three or more cycles of the prescaler underflow for each write interval.
- Do not set 00h to the TRA register in pulse width measurement mode and pulse period measurement mode.

18. Timer RB

Timer RB is an 8-bit timer with an 8-bit prescaler.

18.1 Overview

The prescaler and timer each consist of a reload register and counter (refer to **Tables 18.2 to 18.5 the Specifications of Each Mode**). Timer RB has timer RB primary and timer RB secondary as reload registers. The count source for timer RB is the operating clock that regulates the timing of timer operations such as counting and reloading.

Figure 18.1 shows a Timer RB Block Diagram. Table 18.1 lists Pin Configuration of Timer RB.

Timer RB has four operation modes listed as follows:

- **Timer mode:** The timer counts an internal count source (peripheral function clock or timer RA underflows).
- **Programmable waveform generation mode:** The timer outputs pulses of a given width successively.
- **Programmable one-shot generation mode:** The timer outputs a one-shot pulse.
- **Programmable wait one-shot generation mode:** The timer outputs a delayed one-shot pulse.

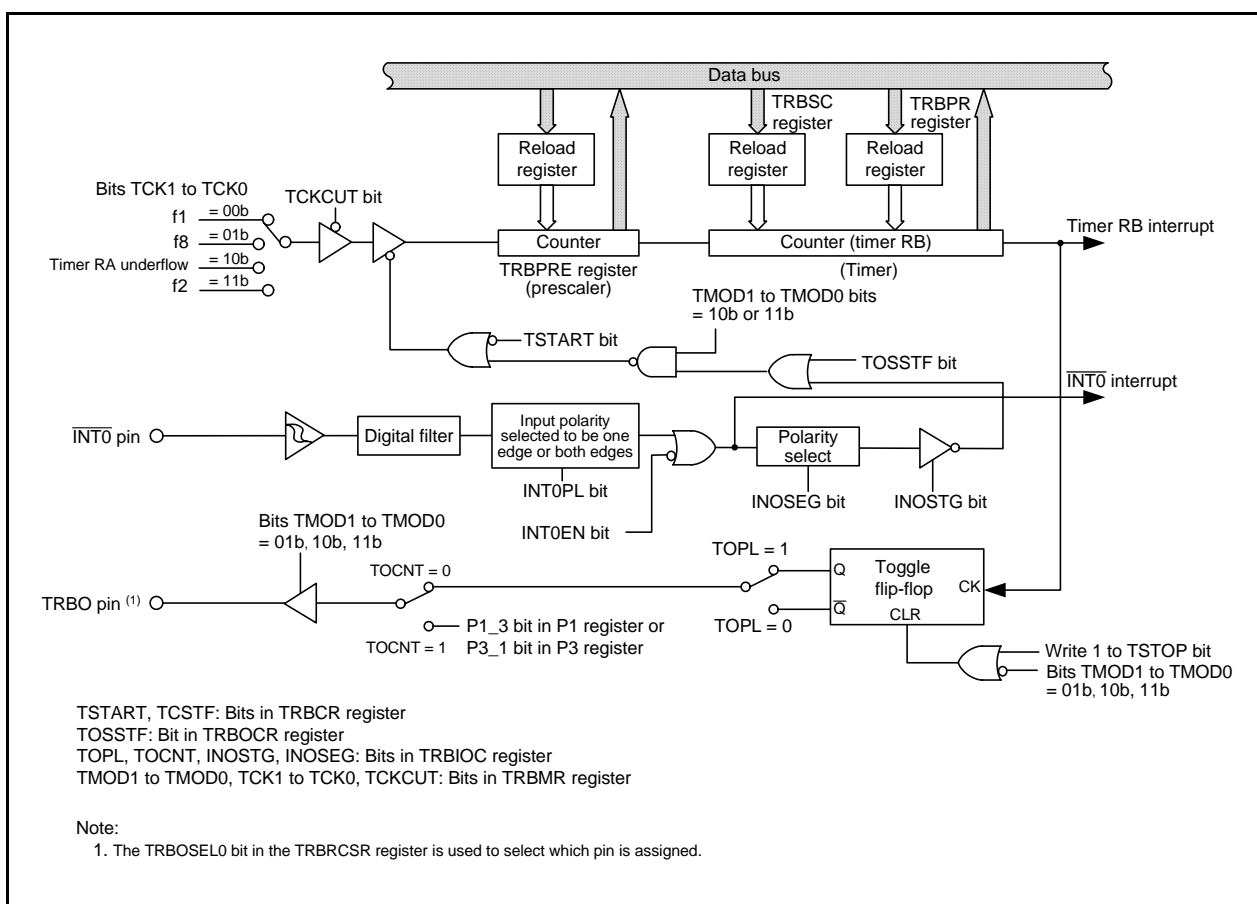

Figure 18.1 Timer RB Block Diagram

Table 18.1 Pin Configuration of Timer RB

Pin Name	Assigned Pin	I/O	Function
TRBO	P1_3 or P3_1	Output	Pulse output (Programmable waveform generation mode, Programmable one-shot generation mode, Programmable wait one-shot generation mode)

18.2 Registers

18.2.1 Timer RB Control Register (TRBCR)

Address 0108h

Bit	b7	b6	b5	b4	b3	b2	b1	b0
Symbol	—	—	—	—	—	TSTOP	TCSTF	TSTART
After Reset	0	0	0	0	0	0	0	0

Bit	Symbol	Bit Name	Function	R/W
b0	TSTART	Timer RB count start bit ⁽¹⁾	0: Count stops 1: Count starts	R/W
b1	TCSTF	Timer RB count status flag ⁽¹⁾	0: Count stops 1: During count ⁽³⁾	R
b2	TSTOP	Timer RB count forcible stop bit ^(1, 2)	When this bit is set to 1, the count is forcibly stopped. When read, the content is 0.	R/W
b3	—	Nothing is assigned. If necessary, set to 0. When read, the content is 0.		—
b4	—			
b5	—			
b6	—			
b7	—			

Notes:

1. Refer to **18.7 Notes on Timer RB** for precautions regarding bits TSTART, TCSTF and TSTOP.
2. When the TSTOP bit is set to 1, registers TRBPRE, TRBSC, TRBPR, and bits TSTART and TCSTF, and the TOSSTF bit in the TRBOCR register are set to values after a reset.
3. Indicates that count operation is in progress in timer mode or programmable waveform mode. In programmable one-shot generation mode or programmable wait one-shot generation mode, indicates that a one-shot pulse trigger has been acknowledged.

18.2.2 Timer RB One-Shot Control Register (TRBOCR)

Address 0109h

Bit	b7	b6	b5	b4	b3	b2	b1	b0
Symbol	—	—	—	—	—	TOSSTF	TOSSP	TOSST
After Reset	0	0	0	0	0	0	0	0

Bit	Symbol	Bit Name	Function	R/W
b0	TOSST	Timer RB one-shot start bit	When this bit is set to 1, one-shot trigger generated. When read, its content is 0.	R/W
b1	TOSSP	Timer RB one-shot stop bit	When this bit is set to 1, counting of one-shot pulses (including programmable wait one-shot pulses) stops. When read, the content is 0.	R/W
b2	TOSSTF	Timer RB one-shot status flag ⁽¹⁾	0: One-shot stopped 1: One-shot operating (Including wait period)	R
b3	—	Nothing is assigned. If necessary, set to 0. When read, the content is 0.		—
b4	—			
b5	—			
b6	—			
b7	—			

Note:

1. When 1 is set to the TSTOP bit in the TRBCR register, the TOSSTF bit is set to 0.

This register is enabled when bits TMOD1 to TMOD0 in the TRBMR register is set to 10b (programmable one-shot generation mode) or 11b (programmable wait one-shot generation mode).

18.2.3 Timer RB I/O Control Register (TRBIOC)

Address 010Ah

Bit	b7	b6	b5	b4	b3	b2	b1	b0
Symbol	—	—	—	—	INOSEG	INOSTG	TOCNT	TOPL
After Reset	0	0	0	0	0	0	0	0

Bit	Symbol	Bit Name	Function	R/W
b0	TOPL	Timer RB output level select bit	Function varies according to the operating mode.	R/W
b1	TOCNT	Timer RB output switch bit		R/W
b2	INOSTG	One-shot trigger control bit		R/W
b3	INOSEG	One-shot trigger polarity select bit		R/W
b4	—	Nothing is assigned. If necessary, set to 0. When read, the content is 0.		—
b5	—			
b6	—			
b7	—			

18.2.4 Timer RB Mode Register (TRBMR)

Address 010Bh

Bit	b7	b6	b5	b4	b3	b2	b1	b0
Symbol	TCKCUT	—	TCK1	TCK0	TWRC	—	TMOD1	TMOD0
After Reset	0	0	0	0	0	0	0	0

Bit	Symbol	Bit Name	Function	R/W
b0	TMOD0	Timer RB operating mode select bit (1)	^{b1 b0} 0 0: Timer mode 0 1: Programmable waveform generation mode 1 0: Programmable one-shot generation mode 1 1: Programmable wait one-shot generation mode	R/W
b1	TMOD1			R/W
b2	—	Nothing is assigned. If necessary, set to 0. When read, the content is 0.		—
b3	TWRC	Timer RB write control bit (2)	0: Write to reload register and counter 1: Write to reload register only	R/W
b4	TCK0	Timer RB count source select bit (1)	^{b5 b4} 0 0: f1 0 1: f8 1 0: Timer RA underflow (3) 1 1: f2	R/W
b5	TCK1			R/W
b6	—	Nothing is assigned. If necessary, set to 0. When read, the content is 0.		—
b7	TCKCUT	Timer RB count source cutoff bit (1)	0: Provides count source 1: Cuts off count source	R/W

Notes:

- Change bits TMOD1 and TMOD0; TCK1 and TCK0; and TCKCUT when both the TSTART and TCSTF bits in the TRBCR register set to 0 (count stops).
- The TWRC bit can be set to either 0 or 1 in timer mode. In programmable waveform generation mode, programmable one-shot generation mode, or programmable wait one-shot generation mode, the TWRC bit must be set to 1 (write to reload register only).
- To use the underflow signal of timer RA as the count source for timer RB, set timer RA in timer mode, pulse output mode, or event count mode.

18.2.5 Timer RB Prescaler Register (TRBPRES)

Address 010Ch

Bit	b7	b6	b5	b4	b3	b2	b1	b0
Symbol	—	—	—	—	—	—	—	—
After Reset	1	1	1	1	1	1	1	1

Bit	Mode	Function	Setting Range	R/W
b7 to b0	Timer mode	Counts an internal count source or timer RA underflows	00h to FFh	R/W
	Programmable waveform generation mode		00h to FFh	R/W
	Programmable one-shot generation mode		00h to FFh	R/W
	Programmable wait one-shot generation mode		00h to FFh	R/W

When the TSTOP bit in the TRBCR register is set to 1, the TRBPRES register is set to FFh.

18.2.6 Timer RB Secondary Register (TRBSC)

Address 010Dh

Bit	b7	b6	b5	b4	b3	b2	b1	b0
Symbol	—	—	—	—	—	—	—	—
After Reset	1	1	1	1	1	1	1	1

Bit	Mode	Function	Setting Range	R/W
b7 to b0	Timer mode	Disabled	00h to FFh	—
	Programmable waveform generation mode	Counts timer RB prescaler underflows ⁽¹⁾	00h to FFh	W ⁽²⁾
	Programmable one-shot generation mode	Disabled	00h to FFh	—
	Programmable wait one-shot generation mode	Counts timer RB prescaler underflows (one-shot width is counted)	00h to FFh	W ⁽²⁾

Notes:

1. The values of registers TRBPR and TRBSC are reloaded to the counter alternately and counted.
2. The count value can be read out by reading the TRBPR register even when the secondary period is being counted.

When the TSTOP bit in the TRBCR register is set to 1, the TRBSC register is set to FFh.

To write to the TRBSC register, perform the following steps.

- (1) Write the value to the TRBSC register.
- (2) Write the value to the TRBPR register. (If the value does not change, write the same value second time.)

18.2.7 Timer RB Primary Register (TRBPR)

Address 010Eh

Bit	b7	b6	b5	b4	b3	b2	b1	b0
Symbol	—	—	—	—	—	—	—	—
After Reset	1	1	1	1	1	1	1	1

Bit	Mode	Function	Setting Range	R/W
b7 to b0	Timer mode	Counts timer RB prescaler underflows	00h to FFh	R/W
	Programmable waveform generation mode	Counts timer RB prescaler underflows (1)	00h to FFh	R/W
	Programmable one-shot generation mode	Counts timer RB prescaler underflows (one-shot width is counted)	00h to FFh	R/W
	Programmable wait one-shot generation mode	Counts timer RB prescaler underflows (wait period width is counted)	00h to FFh	R/W

Note:

- The values of registers TRBPR and TRBSC are reloaded to the counter alternately and counted.

When the TSTOP bit in the TRBCR register is set to 1, the TRBPR register is set to FFh.

18.2.8 Timer RB/RC Pin Select Register (TRBRC SR)

Address 0181h

Bit	b7	b6	b5	b4	b3	b2	b1	b0
Symbol	—	—	TRCCLKSEL1	—	—	—	TRBOSEL1	TRBOSEL0
After Reset	0	0	0	0	0	0	0	0

Bit	Symbol	Bit Name	Function	R/W
b0	TRBOSEL0	TRBO pin select bit	b1 b0 0 0: P1_3 assigned 0 1: P3_1 assigned 1 0: Do not set. 1 1: TRBO pin not used	R/W
b1	TRBOSEL1			R/W
b2	—	Nothing is assigned. If necessary, set to 0. When read, the content is 0.		—
b3	—			
b4	—	Reserved bit	Set to 0.	R/W
b5	TRCCLKSEL1	TRCCLK pin select bit	0: TRCCLK pin not used 1: P3_3 assigned	R/W
b6	—	Reserved bit	Set to 0.	R/W
b7	—	Nothing is assigned. If necessary, set to 0. When read, the content is 0.		—

The TRBRC SR register selects which pin is assigned to the timer RB and timer RC I/O. To use the I/O pin for timer RB and timer RC, set this register.

Set bits TRBOSEL0 and TRBOSEL1 before setting the timer RB associated registers. Set bit TRCCLKSEL1 before setting the timer RC associated registers. Also, do not change the setting values of bits TRBOSEL0 and TRBOSEL1 during timer RB operation. Do not change the setting values of bit TRCCLKSEL1 during timer RC operation.

18.3 Timer Mode

In timer mode, a count source which is internally generated or timer RA underflows are counted (refer to **Table 18.2 Timer Mode Specifications**). Registers TRBOCR and TRBSC are not used in timer mode.

Table 18.2 Timer Mode Specifications

Item	Specification
Count sources	f1, f2, f8, timer RA underflow
Count operations	<ul style="list-style-type: none"> • Decrement • When the timer underflows, it reloads the reload register contents before the count continues (when timer RB underflows, the contents of timer RB primary reload register is reloaded).
Divide ratio	$1/(n+1)(m+1)$ n: setting value in TRBPRES register, m: setting value in TRBPR register
Count start condition	1 (count starts) is written to the TSTART bit in the TRBCR register.
Count stop conditions	<ul style="list-style-type: none"> • 0 (count stops) is written to the TSTART bit in the TRBCR register. • 1 (count forcibly stop) is written to the TSTOP bit in the TRBCR register.
Interrupt request generation timing	When timer RB underflows [timer RB interrupt].
TRBO pin function	Programmable I/O port
INT0 pin function	Programmable I/O port or $\overline{\text{INT0}}$ interrupt input
Read from timer	The count value can be read out by reading registers TRBPR and TRBPRES.
Write to timer	<ul style="list-style-type: none"> • When registers TRBPRES and TRBPR are written while the count is stopped, values are written to both the reload register and counter. • When registers TRBPRES and TRBPR are written to while count operation is in progress: If the TWRC bit in the TRBMR register is set to 0, the value is written to both the reload register and the counter. If the TWRC bit is set to 1, the value is written to the reload register only. (Refer to 18.3.2 Timer Write Control during Count Operation.)

18.3.1 Timer RB I/O Control Register (TRBIOC) in Timer Mode

Address 010Ah

Bit	b7	b6	b5	b4	b3	b2	b1	b0
Symbol	—	—	—	—	INOSEG	INOSTG	TOCNT	TOPL
After Reset	0	0	0	0	0	0	0	0

Bit	Symbol	Bit Name	Function	R/W
b0	TOPL	Timer RB output level select bit	Set to 0 in timer mode.	R/W
b1	TOCNT	Timer RB output switch bit		R/W
b2	INOSTG	One-shot trigger control bit		R/W
b3	INOSEG	One-shot trigger polarity select bit		R/W
b4	—	Nothing is assigned. If necessary, set to 0. When read, the content is 0.		—
b5	—			
b6	—			
b7	—			

18.3.2 Timer Write Control during Count Operation

Timer RB has a prescaler and a timer (which counts the prescaler underflows). The prescaler and timer each consist of a reload register and a counter. In timer mode, the TWRC bit in the TRBMR register can be used to select whether writing to the prescaler or timer during count operation is performed to both the reload register and counter or only to the reload register.

However, values are transferred from the reload register to the counter of the prescaler in synchronization with the count source. In addition, values are transferred from the reload register to the counter of the timer in synchronization with prescaler underflows. Therefore, even if the TWRC bit is set for writing to both the reload register and counter, the counter value is not updated immediately after the WRITE instruction is executed. In addition, if the TWRC bit is set for writing to the reload register only, the synchronization of the writing will be shifted if the prescaler value changes. Figure 18.2 shows an Operating Example of Timer RB when Counter Value is Rewritten during Count Operation.

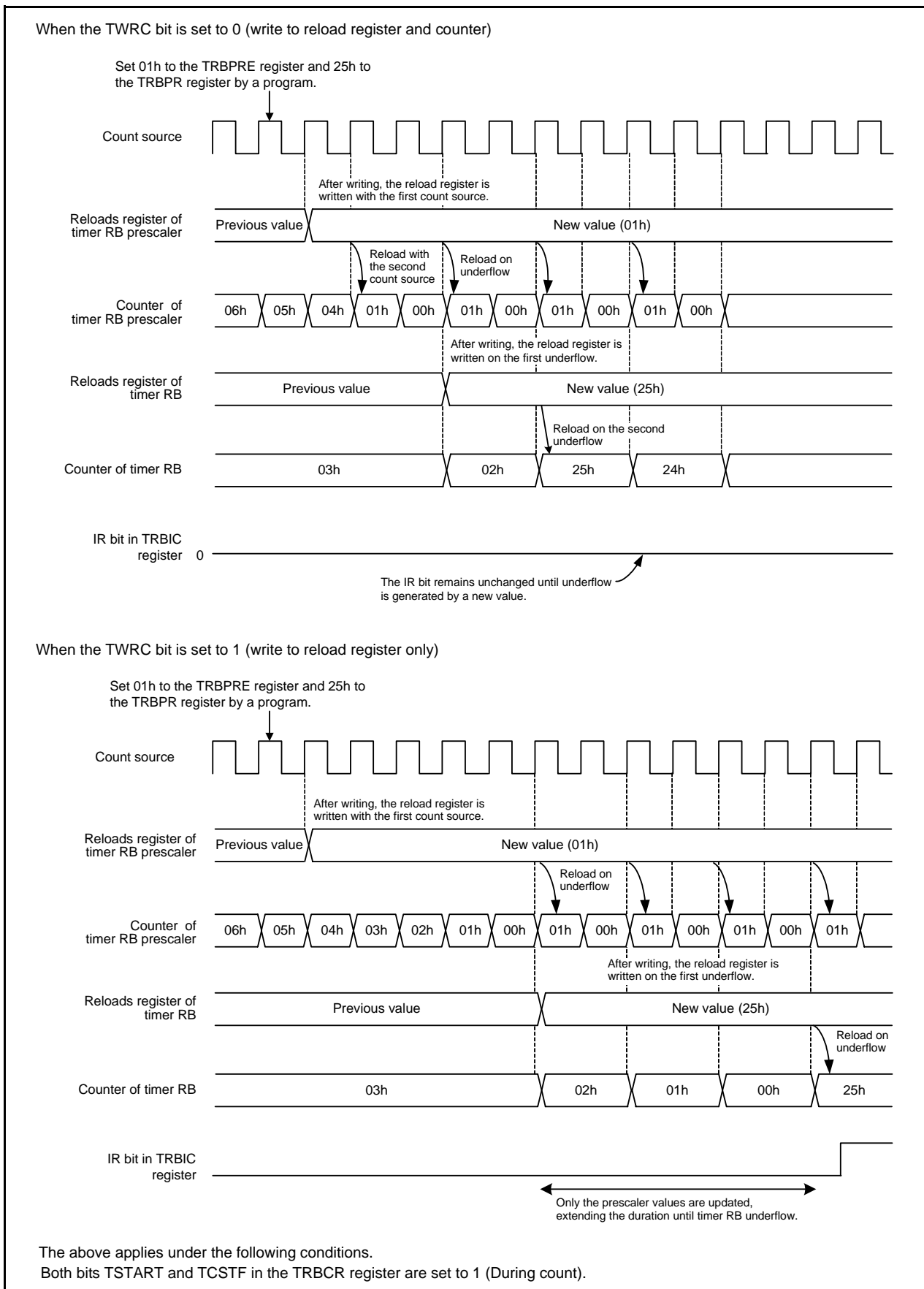

Figure 18.2 Operating Example of Timer RB when Counter Value is Rewritten during Count Operation

18.4 Programmable Waveform Generation Mode

In programmable waveform generation mode, the signal output from the TRBO pin is inverted each time the counter underflows, while the values in registers TRBPR and TRBSC are counted alternately (refer to Table 18.3 Programmable Waveform Generation Mode Specifications). Counting starts by counting the setting value in the TRBPR register. The TRBOCR register is unused in this mode.

Figure 18.3 shows an Operating Example of Timer RB in Programmable Waveform Generation Mode.

Table 18.3 Programmable Waveform Generation Mode Specifications

Item	Specification
Count sources	f1, f2, f8, timer RA underflow
Count operations	<ul style="list-style-type: none"> Decrement When the timer underflows, it reloads the contents of the primary reload and secondary reload registers alternately before the count continues.
Width and period of output waveform	Primary period: $(n+1)(m+1)/f_i$ Secondary period: $(n+1)(p+1)/f_i$ Period: $(n+1)\{(m+1)+(p+1)\}/f_i$ f_i : Count source frequency n : Value set in TRBPRES register, m : Value set in TRBPR register p : Value set in TRBSC register
Count start condition	1 (count start) is written to the TSTART bit in the TRBCR register.
Count stop conditions	<ul style="list-style-type: none"> 0 (count stop) is written to the TSTART bit in the TRBCR register. 1 (count forcibly stop) is written to the TSTOP bit in the TRBCR register.
Interrupt request generation timing	In half a cycle of the count source, after timer RB underflows during the secondary period (at the same time as the TRBO output change) [timer RB interrupt]
TRBO pin function	Programmable output port or pulse output
INT0 pin function	Programmable I/O port or INT0 interrupt input
Read from timer	The count value can be read out by reading registers TRBPR and TRBPRES (1).
Write to timer	<ul style="list-style-type: none"> When registers TRBPRES, TRBSC, and TRBPR are written while the count is stopped, values are written to both the reload register and counter. When registers TRBPRES, TRBSC, and TRBPR are written to during count operation, values are written to the reload registers only. (2)
Selectable functions	<ul style="list-style-type: none"> Output level select function The output level during primary and secondary periods is selected by the TOPL bit in the TRBIOC register. TRBO pin output switch function Timer RB pulse output or P3_1 (P1_3) latch output is selected by the TOCNT bit in the TRBIOC register. (3)

Notes:

- Even when counting the secondary period, the TRBPR register may be read.
- The set values are reflected in the waveform output beginning with the following primary period after writing to the TRBPR register.
- The value written to the TOCNT bit is enabled by the following.
 - When counting starts.
 - When a timer RB interrupt request is generated.
 The contents after the TOCNT bit is changed are reflected from the output of the following primary period.

18.4.1 Timer RB I/O Control Register (TRBIOC) in Programmable Waveform Generation Mode

Address 010Ah

Bit	b7	b6	b5	b4	b3	b2	b1	b0
Symbol	—	—	—	—	INOSEG	INOSTG	TOCNT	TOPL
After Reset	0	0	0	0	0	0	0	0

Bit	Symbol	Bit Name	Function	R/W
b0	TOPL	Timer RB output level select bit	0: Outputs "H" for primary period Outputs "L" for secondary period Outputs "L" when the timer is stopped 1: Outputs "L" for primary period Outputs "H" for secondary period Outputs "H" when the timer is stopped	R/W
b1	TOCNT	Timer RB output switch bit	0: Outputs timer RB waveform 1: Outputs value in P3_1 (P1_3) port register	R/W
b2	INOSTG	One-shot trigger control bit	Set to 0 in programmable waveform generation mode.	R/W
b3	INOSEG	One-shot trigger polarity select bit		R/W
b4	—	Nothing is assigned. If necessary, set to 0. When read, the content is 0.		—
b5	—			
b6	—			
b7	—			

18.4.2 Operating Example

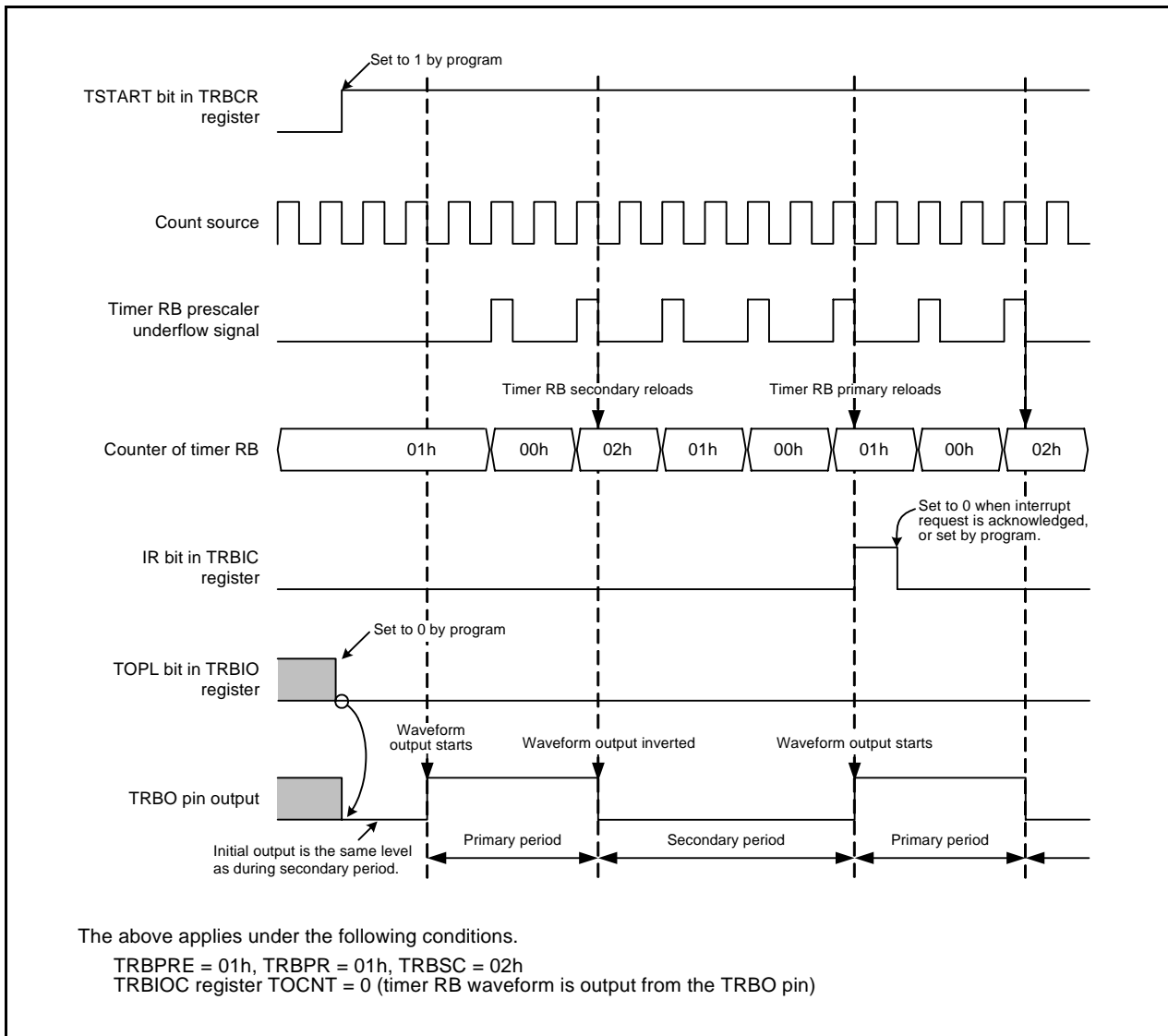

Figure 18.3 Operating Example of Timer RB in Programmable Waveform Generation Mode

18.5 Programmable One-shot Generation Mode

In programmable one-shot generation mode, a one-shot pulse is output from the TRBO pin by a program or an external trigger input (input to the $\overline{\text{INT0}}$ pin) (refer to **Table 18.4 Programmable One-Shot Generation Mode Specifications**). When a trigger is generated, the timer starts operating from the point only once for a given period equal to the set value in the TRBPR register. The TRBSC register is not used in this mode.

Figure 18.4 shows an Operating Example of Programmable One-Shot Generation Mode.

Table 18.4 Programmable One-Shot Generation Mode Specifications

Item	Specification
Count sources	f1, f2, f8, timer RA underflow
Count operations	<ul style="list-style-type: none"> Decrement the setting value in the TRBPR register When the timer underflows, it reloads the contents of the reload register before the count completes and the TOSSTF bit is set to 0 (one-shot stops). When the count stops, the timer reloads the contents of the reload register before it stops.
One-shot pulse output time	$(n+1)(m+1)/f_i$ f_i : Count source frequency, n : Setting value in TRBPRES register, m : Setting value in TRBPR register
Count start conditions	<ul style="list-style-type: none"> The TSTART bit in the TRBCR register is set to 1 (count starts) and the next trigger is generated Set the TOSST bit in the TRBOCR register to 1 (one-shot starts) Input trigger to the $\overline{\text{INT0}}$ pin
Count stop conditions	<ul style="list-style-type: none"> When reloading completes after timer RB underflows during primary period When the TOSSP bit in the TRBOCR register is set to 1 (one-shot stops) When the TSTART bit in the TRBCR register is set to 0 (stops counting) When the TSTOP bit in the TRBCR register is set to 1 (forcibly stops counting)
Interrupt request generation timing	In half a cycle of the count source, after the timer underflows (at the same time as the TRBO output ends) [timer RB interrupt]
TRBO pin function	Pulse output
$\overline{\text{INT0}}$ pin functions	<ul style="list-style-type: none"> When the INOSTG bit in the TRBIOC register is set to 0 ($\overline{\text{INT0}}$ one-shot trigger disabled): programmable I/O port or $\overline{\text{INT0}}$ interrupt input When the INOSTG bit in the TRBIOC register is set to 1 ($\overline{\text{INT0}}$ one-shot trigger enabled): external trigger ($\overline{\text{INT0}}$ interrupt input)
Read from timer	The count value can be read out by reading registers TRBPR and TRBPRES.
Write to timer	<ul style="list-style-type: none"> When registers TRBPRES and TRBPR are written while the count is stopped, values are written to both the reload register and counter. When registers TRBPRES and TRBPR are written during the count, values are written to the reload register only (the data is transferred to the counter at the following reload) ⁽¹⁾.
Selectable functions	<ul style="list-style-type: none"> Output level select function The output level of the one-shot pulse waveform is selected by the TOPL bit in the TRBIOC register. One-shot trigger select function Refer to 18.5.3 One-Shot Trigger Selection.

Note:

- The set value is reflected at the following one-shot pulse after writing to the TRBPR register.

18.5.1 Timer RB I/O Control Register (TRBIOC) in Programmable One-Shot Generation Mode

Address 010Ah

Bit	b7	b6	b5	b4	b3	b2	b1	b0
Symbol	—	—	—	—	INOSEG	INOSTG	TOCNT	TOPL
After Reset	0	0	0	0	0	0	0	0

Bit	Symbol	Bit Name	Function	R/W
b0	TOPL	Timer RB output level select bit	0: Outputs one-shot pulse "H" Outputs "L" when the timer is stopped 1: Outputs one-shot pulse "L" Outputs "H" when the timer is stopped	R/W
b1	TOCNT	Timer RB output switch bit	Set to 0 in programmable one-shot generation mode.	R/W
b2	INOSTG	One-shot trigger control bit ⁽¹⁾	0: $\overline{\text{INT0}}$ pin one-shot trigger disabled 1: INT0 pin one-shot trigger enabled	R/W
b3	INOSEG	One-shot trigger polarity select bit ⁽¹⁾	0: Falling edge trigger 1: Rising edge trigger	R/W
b4	—	Nothing is assigned. If necessary, set to 0. When read, the content is 0.		—
b5	—			
b6	—			
b7	—			

Note:

1. Refer to **18.5.3 One-Shot Trigger Selection**.

18.5.2 Operating Example

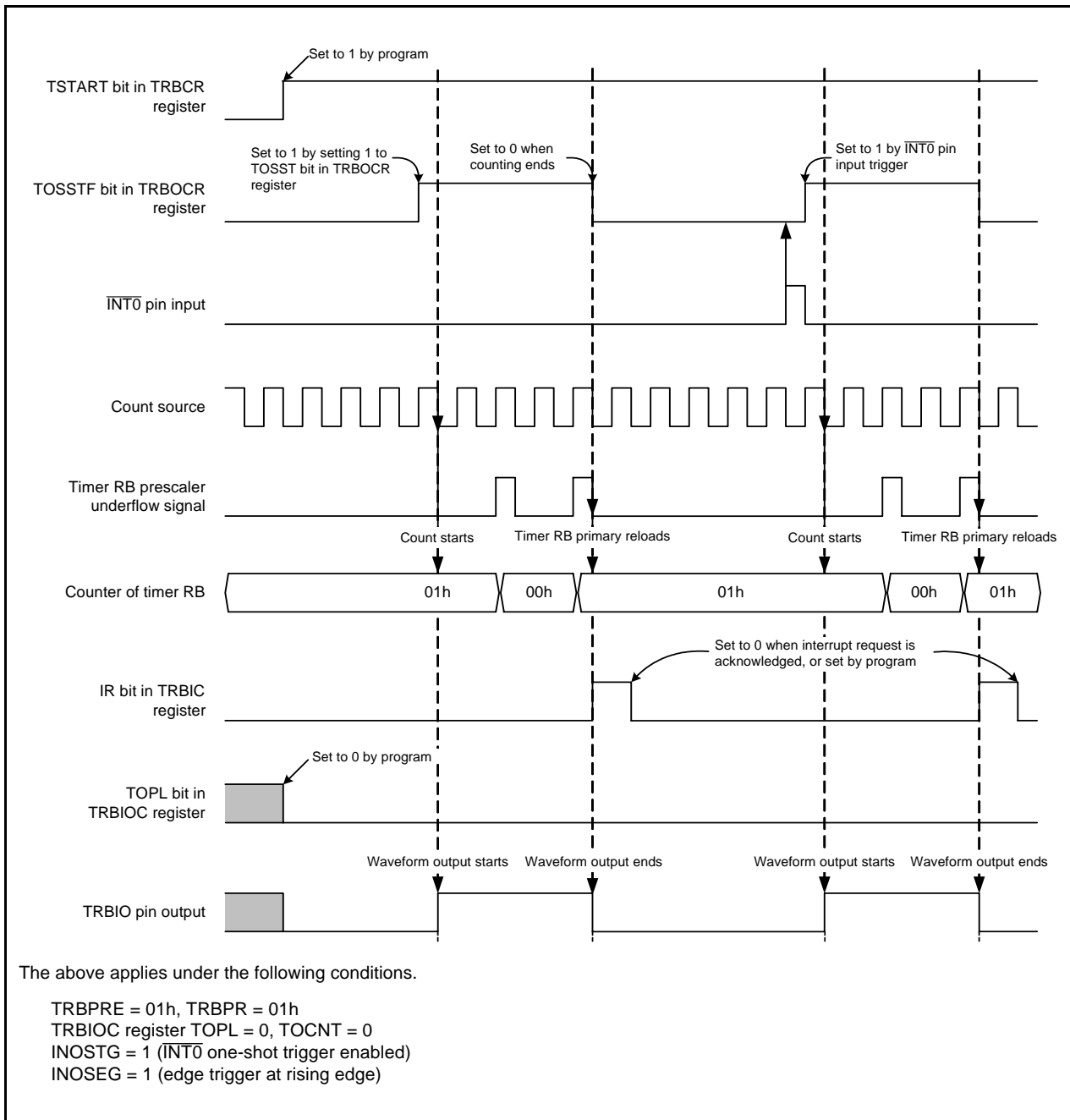

Figure 18.4 Operating Example of Programmable One-Shot Generation Mode

18.5.3 One-Shot Trigger Selection

In programmable one-shot generation mode and programmable wait one-shot generation mode, operation starts when a one-shot trigger is generated while the TCSTF bit in the TRBCR register is set to 1 (count starts).

A one-shot trigger can be generated by either of the following causes:

- 1 is written to the TOSST bit in the TRBOCR register by a program.
- Trigger input from the $\overline{\text{INT0}}$ pin.

When a one-shot trigger occurs, the TOSSTF bit in the TRBOCR register is set to 1 (one-shot operation in progress) after one or two cycles of the count source have elapsed. Then, in programmable one-shot generation mode, count operation begins and one-shot waveform output starts. (In programmable wait one-shot generation mode, count operation starts for the wait period.) If a one-shot trigger occurs while the TOSSTF bit is set to 1, no retriggering occurs.

To use trigger input from the $\overline{\text{INT0}}$ pin, input the trigger after making the following settings:

- Set the PD4_5 bit in the PD4 register to 0 (input port).
- Select the $\overline{\text{INT0}}$ digital filter with bits INT0F1 and INT0F0 in the INTF register.
- Select both edges or one edge with the INT0PL bit in INTEN register. If one edge is selected, further select falling or rising edge with the INOSEG bit in TRBIOC register.
- Set the INT0EN bit in the INTEN register to 1 (enabled).
- After completing the above, set the INOSTG bit in the TRBIOC register to 1 ($\overline{\text{INT0}}$ pin one-shot trigger enabled).

Note the following points with regard to generating interrupt requests by trigger input from the $\overline{\text{INT0}}$ pin.

- Processing to handle the interrupts is required. Refer to **11. Interrupts**, for details.
- If one edge is selected, use the POL bit in the INT0IC register to select falling or rising edge. (The INOSEG bit in the TRBIOC register does not affect $\overline{\text{INT0}}$ interrupts).
- If a one-shot trigger occurs while the TOSSTF bit is set to 1, timer RB operation is not affected, but the value of the IR bit in the INT0IC register changes.

18.6 Programmable Wait One-Shot Generation Mode

In programmable wait one-shot generation mode, a one-shot pulse is output from the TRBO pin by a program or an external trigger input (input to the $\overline{\text{INT0}}$ pin) (refer to Table 18.5 Programmable Wait One-Shot Generation Mode Specifications). When a trigger is generated from that point, the timer outputs a pulse only once for a given length of time equal to the setting value in the TRBSC register after waiting for a given length of time equal to the setting value in the TRBPR register.

Figure 18.5 shows an Operating Example of Programmable Wait One-Shot Generation Mode.

Table 18.5 Programmable Wait One-Shot Generation Mode Specifications

Item	Specification
Count sources	f1, f2, f8, timer RA underflow
Count operations	<ul style="list-style-type: none"> Decrement the timer RB primary setting value. When a count of the timer RB primary underflows, the timer reloads the contents of timer RB secondary before the count continues. When a count of the timer RB secondary underflows, the timer reloads the contents of timer RB primary before the count completes and the TOSSTF bit is set to 0 (one-shot stops). When the count stops, the timer reloads the contents of the reload register before it stops.
Wait time	$(n+1)(m+1)/f_i$ f_i : Count source frequency n : Value set in the TRBPRES register, m : Value set in the TRBPR register
One-shot pulse output time	$(n+1)(p+1)/f_i$ f_i : Count source frequency n : Value set in the TRBPRES register, p : Value set in the TRBSC register
Count start conditions	<ul style="list-style-type: none"> The TSTART bit in the TRBCR register is set to 1 (count starts) and the next trigger is generated. Set the TOSST bit in the TRBOCR register to 1 (one-shot starts). Input trigger to the $\overline{\text{INT0}}$ pin
Count stop conditions	<ul style="list-style-type: none"> When reloading completes after timer RB underflows during secondary period. When the TOSSP bit in the TRBOCR register is set to 1 (one-shot stops). When the TSTART bit in the TRBCR register is set to 0 (starts counting). When the TSTOP bit in the TRBCR register is set to 1 (forcibly stops counting).
Interrupt request generation timing	In half a cycle of the count source after timer RB underflows during secondary period (complete at the same time as waveform output from the TRBO pin) [timer RB interrupt].
TRBO pin function	Pulse output
$\overline{\text{INT0}}$ pin functions	<ul style="list-style-type: none"> When the INOSTG bit in the TRBIOC register is set to 0 ($\overline{\text{INT0}}$ one-shot trigger disabled): programmable I/O port or $\overline{\text{INT0}}$ interrupt input When the INOSTG bit in the TRBIOC register is set to 1 ($\overline{\text{INT0}}$ one-shot trigger enabled): external trigger ($\overline{\text{INT0}}$ interrupt input)
Read from timer	The count value can be read out by reading registers TRBPR and TRBPRES.
Write to timer	<ul style="list-style-type: none"> When registers TRBPRES, TRBSC, and TRBPR are written while the count stops, values are written to both the reload register and counter. When registers TRBPRES, TRBSC, and TRBPR are written to during count operation, values are written to the reload registers only. ⁽¹⁾
Selectable functions	<ul style="list-style-type: none"> Output level select function The output level of the one-shot pulse waveform is selected by the TOPL bit in the TRBIOC register. One-shot trigger select function Refer to 18.5.3 One-Shot Trigger Selection.

Note:

- The set value is reflected at the following one-shot pulse after writing to registers TRBSC and TRBPR.

18.6.1 Timer RB I/O Control Register (TRBIOC) in Programmable Wait One-Shot Generation Mode

Address 010Ah

Bit	b7	b6	b5	b4	b3	b2	b1	b0
Symbol	—	—	—	—	INOSEG	INOSTG	TOCNT	TOPL
After Reset	0	0	0	0	0	0	0	0

Bit	Symbol	Bit Name	Function	R/W
b0	TOPL	Timer RB output level select bit	0: Outputs one-shot pulse "H" Outputs "L" when the timer stops or during wait 1: Outputs one-shot pulse "L" Outputs "H" when the timer stops or during wait	R/W
b1	TOCNT	Timer RB output switch bit	Set to 0 in programmable wait one-shot generation mode.	R/W
b2	INOSTG	One-shot trigger control bit ⁽¹⁾	0: $\overline{\text{INT0}}$ pin one-shot trigger disabled 1: $\overline{\text{INT0}}$ pin one-shot trigger enabled	R/W
b3	INOSEG	One-shot trigger polarity select bit ⁽¹⁾	0: Falling edge trigger 1: Rising edge trigger	R/W
b4	—	Nothing is assigned. If necessary, set to 0. When read, the content is 0.		—
b5	—			
b6	—			
b7	—			

Note:

1. Refer to **18.5.3 One-Shot Trigger Selection**.

18.6.2 Operating Example

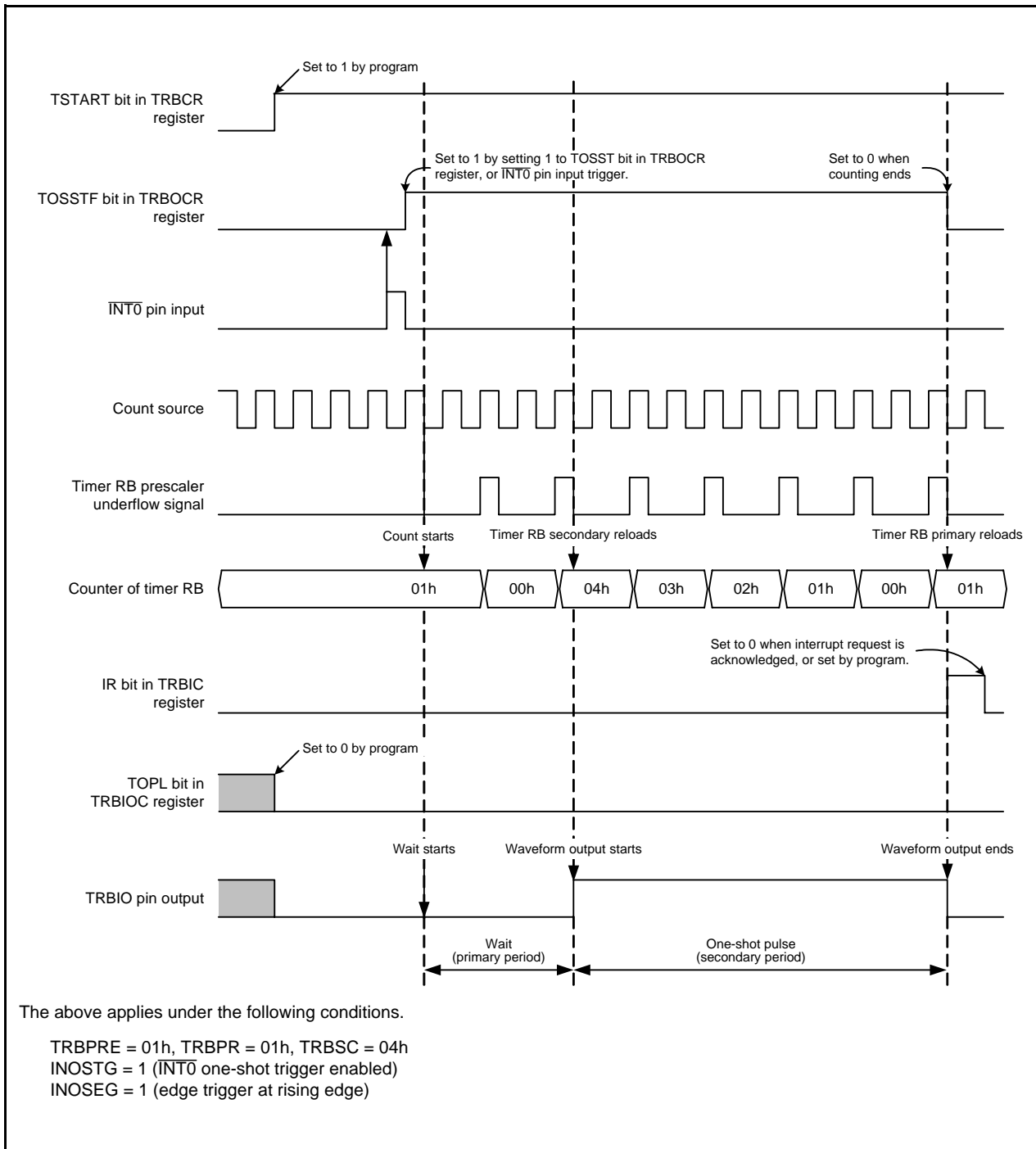

Figure 18.5 Operating Example of Programmable Wait One-Shot Generation Mode

18.7 Notes on Timer RB

- Timer RB stops counting after a reset. Set the values in the timer RB and timer RB prescalers before the count starts.
- Even if the prescaler and timer RB is read out in 16-bit units, these registers are read 1 byte at a time by the MCU. Consequently, the timer value may be updated during the period when these two registers are being read.
- In programmable one-shot generation mode and programmable wait one-shot generation mode, when setting the TSTART bit in the TRBCR register to 0 (stops counting) or setting the TOSSP bit in the TRBOCR register to 1 (stops one-shot), the timer reloads the value of reload register and stops. Therefore, in programmable one-shot generation mode and programmable wait one-shot generation mode, read the timer count value before the timer stops.
- The TCSTF bit remains 0 (count stops) for 1 to 2 cycles of the count source after setting the TSTART bit to 1 (count starts) while the count is stopped.

During this time, do not access registers associated with timer RB ⁽¹⁾ other than the TCSTF bit. Timer RB starts counting at the first valid edge of the count source after the TCSTF bit is set to 1 (during count).

The TCSTF bit remains 1 for 1 to 2 cycles of the count source after setting the TSTART bit to 0 (count stops) while the count is in progress. Timer RB counting is stopped when the TCSTF bit is set to 0.

During this time, do not access registers associated with timer RB ⁽¹⁾ other than the TCSTF bit.

Note:

1. Registers associated with timer RB: TRBCR, TRBOCR, TRBIOC, TRBMR, TRBPRES, TRBSC, and TRBPR.

- If the TSTOP bit in the TRBCR register is set to 1 during timer operation, timer RB stops immediately.
- If 1 is written to the TOSST or TOSSP bit in the TRBOCR register, the value of the TOSSTF bit changes after one or two cycles of the count source have elapsed. If the TOSSP bit is written to 1 during the period between when the TOSST bit is written to 1 and when the TOSSTF bit is set to 1, the TOSSTF bit may be set to either 0 or 1 depending on the content state. Likewise, if the TOSST bit is written to 1 during the period between when the TOSSP bit is written to 1 and when the TOSSTF bit is set to 0, the TOSSTF bit may be set to either 0 or 1.
- To use the underflow signal of timer RA as the count source for timer RB, set timer RA in timer mode, pulse output mode, or event count mode.

18.7.1 Timer Mode

To write to registers TRBPRES and TRBPR during count operation (TCSTF bit in the TRBCR register is set to 1), note the following points:

- When the TRBPRES register is written continuously, allow three or more cycles of the count source for each write interval.
- When the TRBPR register is written continuously, allow three or more cycles of the prescaler underflow for each write interval.

18.7.2 Programmable Waveform Generation Mode

To write to registers TRBPRES and TRBPR during count operation (TCSTF bit in the TRBCR register is set to 1), note the following points:

- When the TRBPRES register is written continuously, allow three or more cycles of the count source for each write interval.
- When the TRBPR register is written continuously, allow three or more cycles of the prescaler underflow for each write interval.

18.7.3 Programmable One-shot Generation Mode

To write to registers TRBPRES and TRBPR during count operation (TCSTF bit in the TRBCR register is set to 1), note the following points:

- When the TRBPRES register is written continuously during count operation (TCSTF bit is set to 1), allow three or more cycles of the count source for each write interval.
- When the TRBPR register is written continuously during count operation (TCSTF bit is set to 1), allow three or more cycles of the prescaler underflow for each write interval.

18.7.4 Programmable Wait One-shot Generation Mode

To write to registers TRBPRES and TRBPR during count operation (TCSTF bit in the TRBCR register is set to 1), note the following points:

- When the TRBPRES register is written continuously, allow three or more cycles of the count source for each write interval.
- When the TRBPR register is written continuously, allow three or more cycles of the prescaler underflow for each write interval.

19. Timer RC

Timer RC is a 16-bit timer with four I/O pins.

19.1 Overview

Timer RC uses either f1, fOCO40M or fOCO-F as its operation clock. Table 19.1 lists the Timer RC Operation Clock.

Table 19.1 Timer RC Operation Clock

Condition	Timer RC Operation Clock
Count source is f1, f2, f4, f8, f32, or TRCCLK input (bits TCK2 to TCK0 in TRCCR1 register are set to a value from 000b to 101b)	f1
Count source is fOCO40M (bits TCK2 to TCK0 in TRCCR1 register are set to 110b)	fOCO40M
Count source is fOCO-F (bits TCK2 to TCK0 in TRCCR1 register are set to 111b)	fOCO-F

Table 19.2 lists the Pin Configuration of Timer RC, and Figure 19.1 shows a Timer RC Block Diagram.

Timer RC has three modes.

- Timer mode

- Input capture function The counter value is captured to a register, using an external signal as the trigger.
- Output compare function Matches between the counter and register values are detected. (Pin output state changes when a match is detected.)

The following two modes use the output compare function.

- PWM mode Pulses of a given width are output continuously.
- PWM2 mode A one-shot waveform or PWM waveform is output following the trigger after the wait time has elapsed.

Input capture function, output compare function, and PWM mode settings may be specified independently for each pin.

In PWM2 mode waveforms are output based on a combination of the counter or the register.

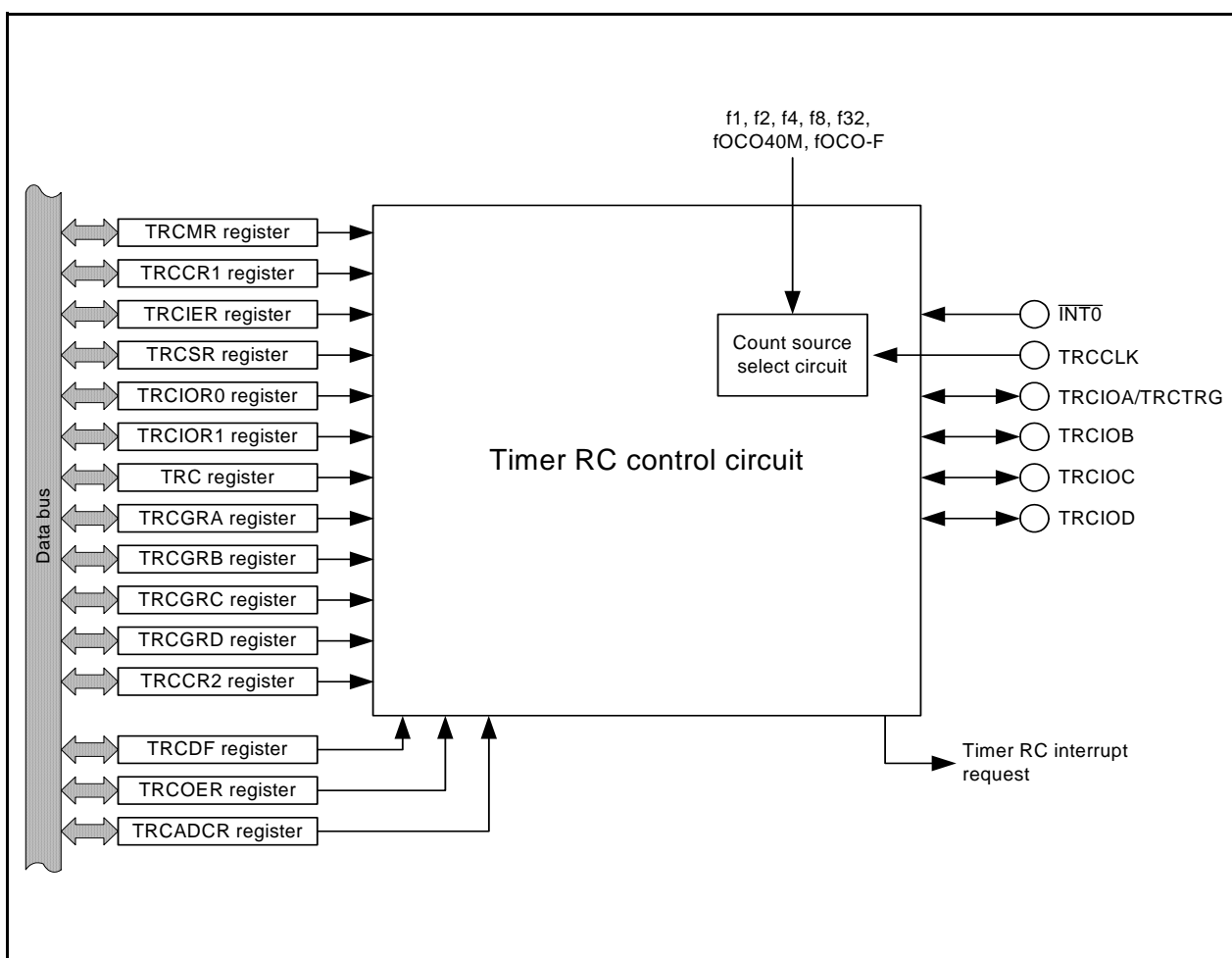

Figure 19.1 Timer RC Block Diagram

Table 19.2 Pin Configuration of Timer RC

Pin Name	Assigned Pin	I/O	Function
TRCIOA	P1_1	I/O	Function differs according to the mode. Refer to descriptions of individual modes for details
TRCIOB	P1_2		
TRCIOC	P3_4 or P5_3		
TRCIOD	P3_5 or P5_4		
TRCCLK	P3_3	Input	External clock input
TRCTRG	P1_1	Input	PWM2 mode external trigger input

19.2 Registers

Table 19.3 lists the Registers Associated with Timer RC.

Table 19.3 Registers Associated with Timer RC

Address	Symbol	Mode				Related Information
		Timer		PWM	PWM2	
		Input Capture Function	Output Compare Function			
0008h	MSTCR	Valid	Valid	Valid	Valid	19.2.1 Module Standby Control Register (MSTCR)
0120h	TRCMR	Valid	Valid	Valid	Valid	19.2.2 Timer RC Mode Register (TRCMR)
0121h	TRCCR1	Valid	Valid	Valid	Valid	Timer RC control register 1 19.2.3 Timer RC Control Register 1 (TRCCR1) 19.5.1 Timer RC Control Register 1 (TRCCR1) for Output Compare Function 19.6.1 Timer RC Control Register 1 (TRCCR1) in PWM Mode 19.7.1 Timer RC Control Register 1 (TRCCR1) in PWM2 Mode
0122h	TRCIER	Valid	Valid	Valid	Valid	19.2.4 Timer RC Interrupt Enable Register (TRCIER)
0123h	TRCSR	Valid	Valid	Valid	Valid	19.2.5 Timer RC Status Register (TRCSR)
0124h	TRCIOR0	Valid	Valid	–	–	Timer RC I/O control register 0, timer RC I/O control register 1 19.2.6 Timer RC I/O Control Register 0 (TRCIOR0) 19.2.7 Timer RC I/O Control Register 1 (TRCIOR1) 19.4.1 Timer RC I/O Control Register 0 (TRCIOR0) for Input Capture Function 19.4.2 Timer RC I/O Control Register 1 (TRCIOR1) for Input Capture Function 19.5.2 Timer RC I/O Control Register 0 (TRCIOR0) for Output Compare Function 19.5.3 Timer RC I/O Control Register 1 (TRCIOR1) for Output Compare Function
0125h	TRCIOR1					
0126h 0127h	TRC	Valid	Valid	Valid	Valid	19.2.8 Timer RC Counter (TRC)
0128h 0129h	TRCGRA	Valid	Valid	Valid	Valid	19.2.9 Timer RC General Registers A, B, C, and D (TRCGRA, TRCGRB, TRCGRC, TRCGRD)
012Ah 012Bh	TRCGRB					
012Ch 012Dh	TRCGRC					
012Eh 012Fh	TRCGRD					
0130h	TRCCR2	–	Valid	Valid	Valid	19.2.10 Timer RC Control Register 2 (TRCCR2)
0131h	TRCDF	Valid	–	–	Valid	19.2.11 Timer RC Digital Filter Function Select Register (TRCDF)
0132h	TRCOER	–	Valid	Valid	Valid	19.2.12 Timer RC Output Master Enable Register (TRCOER)
0133h	TRCADCR	–	Valid	Valid	Valid	19.2.13 Timer RC Trigger Control Register (TRCADCR)
0181h	TRBRCSR	Valid	Valid	Valid	Valid	19.2.14 Timer RB/RC Pin Select Register (TRBRCSR)
0182h	TRCPSR0	Valid	Valid	Valid	Valid	19.2.15 Timer RC Pin Select Register 0 (TRCPSR0)
0183h	TRCPSR1	Valid	Valid	Valid	Valid	19.2.16 Timer RC Pin Select Register 1 (TRCPSR1)

–: Invalid

19.2.1 Module Standby Control Register (MSTCR)

Address 0008h

Bit	b7	b6	b5	b4	b3	b2	b1	b0
Symbol	—	—	MSTTRC	MSTTRD	MSTIIC	—	—	—
After Reset	0	0	0	0	0	0	0	0

Bit	Symbol	Bit Name	Function	R/W
b0	—	Nothing is assigned. If necessary, set to 0. When read, the content is 0.		—
b1	—			
b2	—			
b3	MSTIIC	SSU standby bit	0: Active 1: Standby ⁽¹⁾	R/W
b4	MSTTRD	Timer RD standby bit	0: Active 1: Standby ^(2, 3)	R/W
b5	MSTTRC	Timer RC standby bit	0: Active 1: Standby ⁽⁴⁾	R/W
b6	—	Reserved bit	Set to 0.	R/W
b7	—	Nothing is assigned. If necessary, set to 0. When read, the content is 0.		—

Notes:

1. Stop the SSU and the I²C bus functions before setting to standby. When the MSTIIC bit is set to 1 (standby), any access to the SSU associated registers (addresses 0193h to 019Dh) is disabled.
2. Stop the timer RD function before setting to standby. When the MSTTRD bit is set to 1 (standby), any access to the timer RD associated registers (addresses 0135h to 015Fh) is disabled.
3. To set the MSTTRD bit to 1 (standby), set bits TCK2 to TCK0 in the TRDCR_i (i = 0 or 1) register to 000b (f1).
4. Stop the timer RC function before setting to standby. When the MSTTRC bit is set to 1 (standby), any access to the timer RC associated registers (addresses 0120h to 0133h) is disabled.

19.2.2 Timer RC Mode Register (TRCMR)

Address 0120h

Bit	b7	b6	b5	b4	b3	b2	b1	b0
Symbol	TSTART	—	BFD	BFC	PWM2	PWMD	PWMC	PWMB
After Reset	0	1	0	0	1	0	0	0

Bit	Symbol	Bit Name	Function	R/W
b0	PWMB	PWM mode of TRCIOB select bit ⁽¹⁾	0: Timer mode 1: PWM mode	R/W
b1	PWMC	PWM mode of TRCIOC select bit ⁽¹⁾	0: Timer mode 1: PWM mode	R/W
b2	PWMD	PWM mode of TRCIOD select bit ⁽¹⁾	0: Timer mode 1: PWM mode	R/W
b3	PWM2	PWM2 mode select bit	0: PWM 2 mode 1: Timer mode or PWM mode	R/W
b4	BFC	TRCGRC register function select bit ⁽²⁾	0: General register 1: Buffer register of TRCGRA register	R/W
b5	BFD	TRCGRD register function select bit	0: General register 1: Buffer register of TRCGRB register	R/W
b6	—	Nothing is assigned. If necessary, set to 0. When read, the content is 1.		—
b7	TSTART	TRC count start bit	0: Count stops 1: Count starts	R/W

Notes:

1. These bits are enabled when the PWM2 bit is set to 1 (timer mode or PWM mode).
2. Set the BFC bit to 0 (general register) in PWM2 mode.

For notes on PWM2 mode, refer to **19.9.6 TRCMR Register in PWM2 Mode**.

19.2.3 Timer RC Control Register 1 (TRCCR1)

Address 0121h

Bit	b7	b6	b5	b4	b3	b2	b1	b0
Symbol	CCLR	TCK2	TCK1	TCK0	TOD	TOC	TOB	TOA
After Reset	0	0	0	0	0	0	0	0

Bit	Symbol	Bit Name	Function	R/W
b0	TOA	TRCIOA output level select bit ⁽¹⁾	Function varies according to the operating mode (function).	R/W
b1	TOB	TRCIOB output level select bit ⁽¹⁾		R/W
b2	TOC	TRCIOC output level select bit ⁽¹⁾		R/W
b3	TOD	TRCIOD output level select bit ⁽¹⁾		R/W
b4	TCK0	Count source select bit ⁽¹⁾	b6 b5 b4 0 0 0: f1 0 0 1: f2 0 1 0: f4 0 1 1: f8 1 0 0: f32 1 0 1: TRCCLK input rising edge 1 1 0: fOCO40M 1 1 1: fOCO-F ⁽²⁾	R/W
b5	TCK1			R/W
b6	TCK2			R/W
b7	CCLR	TRC counter clear select bit	0: Disable clear (free-running operation) 1: Clear TRC counter by input capture or by compare match in TRCGRA	R/W

Notes:

1. Set to these bits when the TSTART bit in the TRCMR register is set to 0 (count stops).
2. To select fOCO-F, set it to the clock frequency higher than the CPU clock frequency.

19.2.4 Timer RC Interrupt Enable Register (TRCIER)

Address 0122h

Bit	b7	b6	b5	b4	b3	b2	b1	b0
Symbol	OVIE	—	—	—	IMIED	IMIEC	IMIEB	IMIEA
After Reset	0	1	1	1	0	0	0	0

Bit	Symbol	Bit Name	Function	R/W
b0	IMIEA	Input capture / compare match interrupt enable bit A	0: Disable interrupt (IMIA) by the IMFA bit 1: Enable interrupt (IMIA) by the IMFA bit	R/W
b1	IMIEB	Input capture / compare match interrupt enable bit B	0: Disable interrupt (IMIB) by the IMFB bit 1: Enable interrupt (IMIB) by the IMFB bit	R/W
b2	IMIEC	Input capture / compare match interrupt enable bit C	0: Disable interrupt (IMIC) by the IMFC bit 1: Enable interrupt (IMIC) by the IMFC bit	R/W
b3	IMIED	Input capture / compare match interrupt enable bit D	0: Disable interrupt (IMID) by the IMFD bit 1: Enable interrupt (IMID) by the IMFD bit	R/W
b4	—	Nothing is assigned. If necessary, set to 0. When read, the content is 1.		—
b5	—			
b6	—			
b7	OVIE	Overflow interrupt enable bit	0: Disable interrupt (OVI) by the OVF bit 1: Enable interrupt (OVI) by the OVF bit	R/W

19.2.5 Timer RC Status Register (TRCSR)

Address 0123h

Bit	b7	b6	b5	b4	b3	b2	b1	b0
Symbol	OVF	—	—	—	IMFD	IMFC	IMFB	IMFA
After Reset	0	1	1	1	0	0	0	0

Bit	Symbol	Bit Name	Function	R/W
b0	IMFA	Input capture / compare match flag A	[Source for setting this bit to 0]	R/W
b1	IMFB	Input capture / compare match flag B	Write 0 after read ⁽¹⁾ .	R/W
b2	IMFC	Input capture / compare match flag C	[Source for setting this bit to 1]	R/W
b3	IMFD	Input capture / compare match flag D	Refer to Table 19.4 Source for Setting Bit of Each Flag to 1.	R/W
b4	—	Nothing is assigned. If necessary, set to 0. When read, the content is 1.		—
b5	—			
b6	—			
b7	OVF	Overflow flag	[Source for setting this bit to 0] Write 0 after read ⁽¹⁾ . [Source for setting this bit to 1] Refer to Table 19.4 Source for Setting Bit of Each Flag to 1.	R/W

Note:

1. The writing results are as follows:

- This bit is set to 0 when the read result is 1 and 0 is written to the same bit.
- This bit remains unchanged even if the read result is 0 and 0 is written to the same bit. (This bit remains 1 even if it is set to 1 from 0 after reading, and writing 0.)
- This bit remains unchanged if 1 is written to it.

Table 19.4 Source for Setting Bit of Each Flag to 1

Bit Symbol	Timer Mode		PWM Mode	PWM2 Mode
	Input capture Function	Output Compare Function		
IMFA	TRCIOA pin input edge ⁽¹⁾	When the values of the registers TRC and TRCGRA match.		
IMFB	TRCIOB pin input edge ⁽¹⁾	When the values of the registers TRC and TRCGRB match.		
IMFC	TRCIOC pin input edge ⁽¹⁾	When the values of the registers TRC and TRCGRC match. ⁽²⁾		
IMFD	TRCIOD pin input edge ⁽¹⁾	When the values of the registers TRC and TRCGRD match. ⁽²⁾		
OVF	When the TRC register overflows.			

Notes:

1. Edge selected by bits IOj1 to IOj0 (j = A, B, C, or D).
2. Includes the condition that bits BFC and BFD are set to 1 (buffer registers of registers TRCGRA and TRCGRB).

19.2.6 Timer RC I/O Control Register 0 (TRCIOR0)

Address 0124h

Bit	b7	b6	b5	b4	b3	b2	b1	b0
Symbol	—	IOB2	IOB1	IOB0	IOA3	IOA2	IOA1	IOA0
After Reset	1	0	0	0	1	0	0	0

Bit	Symbol	Bit Name	Function	R/W
b0	IOA0	TRCGRA control bit	Function varies according to the operating mode (function).	R/W
b1	IOA1			R/W
b2	IOA2	TRCGRA mode select bit ⁽¹⁾	0: Output compare function 1: Input capture function	R/W
b3	IOA3	TRCGRA input capture input switch bit ⁽³⁾	0: fOCO128 signal 1: TRCIOA pin input	R/W
b4	IOB0	TRCGRB control bit	Function varies according to the operating mode (function).	R/W
b5	IOB1			R/W
b6	IOB2	TRCGRB mode select bit ⁽²⁾	0: Output compare function 1: Input capture function	R/W
b7	—	Nothing is assigned. If necessary, set to 0. When read, the content is 1.		—

Notes:

1. When the BFC bit in the TRCMR register is set to 1 (buffer register of TRCGRA register), set the IOC2 bit in the TRCIOR1 register to the same value as the IOA2 bit in the TRCIOR0 register.
2. When the BFD bit in the TRCMR register is set to 1 (buffer register of TRCGRB register), set the IOD2 bit in the TRCIOR1 register to the same value as the IOB2 bit in the TRCIOR0 register.
3. The IOA3 bit is enabled when the IOA2 bit is set to 1 (input capture function).

The TRCIOR0 register is enabled in timer mode. It is disabled in modes PWM and PWM2.

19.2.7 Timer RC I/O Control Register 1 (TRCIOR1)

Address 0125h

Bit	b7	b6	b5	b4	b3	b2	b1	b0
Symbol	IOD3	IOD2	IOD1	IOD0	IOC3	IOC2	IOC1	IOC0
After Reset	1	0	0	0	1	0	0	0

Bit	Symbol	Bit Name	Function	R/W
b0	IOC0	TRCGRC control bit	Function varies according to the operating mode (function).	R/W
b1	IOC1			R/W
b2	IOC2	TRCGRC mode select bit ⁽¹⁾	0: Output compare function 1: Input capture function	R/W
b3	IOC3	TRCGRC register function select bit	0: TRCIOA output register 1: General register or buffer register	R/W
b4	IOD0	TRCGRD control bit	Function varies according to the operating mode (function).	R/W
b5	IOD1			R/W
b6	IOD2	TRCGRD mode select bit ⁽²⁾	0: Output compare function 1: Input capture function	R/W
b7	IOD3	TRCGRD register function select bit	0: TRCIOB output register 1: General register or buffer register	R/W

Notes:

1. When the BFC bit in the TRCMR register is set to 1 (buffer register of TRCGRA register), set the IOC2 bit in the TRCIOR1 register to the same value as the IOA2 bit in the TRCIOR0 register.
2. When the BFD bit in the TRCMR register is set to 1 (buffer register of TRCGRB register), set the IOD2 bit in the TRCIOR1 register to the same value as the IOB2 bit in the TRCIOR0 register.

The TRCIOR1 register is enabled in timer mode. It is disabled in modes PWM and PWM2.

19.2.8 Timer RC Counter (TRC)

Address 0127h to 0126h

Bit	b7	b6	b5	b4	b3	b2	b1	b0
Symbol	—	—	—	—	—	—	—	—
After Reset	0	0	0	0	0	0	0	0

Bit	b15	b14	b13	b12	b11	b10	b9	b8
Symbol	—	—	—	—	—	—	—	—
After Reset	0	0	0	0	0	0	0	0

Bit	Function	Setting Range	R/W
b15 to b0	Count a count source. Count operation is incremented. When an overflow occurs, the OVF bit in the TRCSR register is set to 1.	0000h to FFFFh	R/W

Access the TRC register in 16-bit units. Do not access it in 8-bit units.

19.2.9 Timer RC General Registers A, B, C, and D (TRCGRA, TRCGRB, TRCGRC, TRCGRD)

Address 0129h to 0128h (TRCGRA), 012Bh to 012Ah (TRCGRB), 012Dh to 012Ch (TRCGRC), 012Fh to 012Eh (TRCGRD)

Bit	b7	b6	b5	b4	b3	b2	b1	b0
Symbol	—	—	—	—	—	—	—	—
After Reset	1	1	1	1	1	1	1	1

Bit	b15	b14	b13	b12	b11	b10	b9	b8
Symbol	—	—	—	—	—	—	—	—
After Reset	1	1	1	1	1	1	1	1

Bit	Function	R/W
b15 to b0	Function varies according to the operating mode.	R/W

Access registers TRCGRA to TRCGRD in 16-bit units. Do not access them in 8-bit units.

19.2.10 Timer RC Control Register 2 (TRCCR2)

Address 0130h

Bit	b7	b6	b5	b4	b3	b2	b1	b0
Symbol	TCEG1	TCEG0	CSEL	—	—	POLD	POLC	POLB
After Reset	0	0	0	1	1	0	0	0

Bit	Symbol	Bit Name	Function	R/W
b0	POLB	PWM mode output level control bit B ⁽¹⁾	0: TRCIOB output level selected as “L” active 1: TRCIOB output level selected as “H” active	R/W
b1	POLC	PWM mode output level control bit C ⁽¹⁾	0: TRCIOC output level selected as “L” active 1: TRCIOC output level selected as “H” active	R/W
b2	POLD	PWM mode output level control bit D ⁽¹⁾	0: TRCIOD output level selected as “L” active 1: TRCIOD output level selected as “H” active	R/W
b3	—	Nothing is assigned. If necessary, set to 0. When read, the content is 1.		—
b4	—			
b5	CSEL	TRC count operation select bit ⁽²⁾	0: Count continues at compare match with the TRCGRA register 1: Count stops at compare match with the TRCGRA register	R/W
b6	TCEG0	TRCTRG input edge select bit ⁽³⁾	b7 b6 0 0: Disable the trigger input from the TRCTRG pin 0 1: Rising edge selected 1 0: Falling edge selected 1 1: Both edges selected	R/W
b7	TCEG1			R/W

Notes:

1. Enabled when in PWM mode.
2. Enabled when in output compare function, PWM mode, or PWM2 mode. For notes on PWM2 mode, refer to **19.9.6 TRCMR Register in PWM2 Mode**.
3. Enabled when in PWM2 mode.

19.2.11 Timer RC Digital Filter Function Select Register (TRCDF)

Address 0131h

Bit	b7	b6	b5	b4	b3	b2	b1	b0
Symbol	DFCK1	DFCK0	—	DFTRG	DFD	DFC	DFB	DFA
After Reset	0	0	0	0	0	0	0	0

Bit	Symbol	Bit Name	Function	R/W
b0	DFA	TRCIOA pin digital filter function select bit ⁽¹⁾	0: Function is not used 1: Function is used	R/W
b1	DFB	TRCIOB pin digital filter function select bit ⁽¹⁾		R/W
b2	DFC	TRCIOC pin digital filter function select bit ⁽¹⁾		R/W
b3	DFD	TRCIOD pin digital filter function select bit ⁽¹⁾		R/W
b4	DFTRG	TRCTRG pin digital filter function select bit ⁽²⁾		R/W
b5	—	Nothing is assigned. If necessary, set to 0. When read, the content is 0.		—
b6	DFCK0	Clock select bits for digital filter function ^(1, 2)	b7 b6 0 0: f32 0 1: f8 1 0: f1 1 1: Count source (clock selected by bits TCK2 to TCK0 in the TRCCR1 register)	R/W
b7	DFCK1			R/W

Notes:

1. These bits are enabled for the input capture function.
2. These bits are enabled when in PWM2 mode and bits TCEG1 to TCEG0 in the TRCCR2 register are set to 01b, 10b, or 11b (TRCTRG trigger input enabled).

19.2.12 Timer RC Output Master Enable Register (TRCOER)

Address 0132h

Bit	b7	b6	b5	b4	b3	b2	b1	b0
Symbol	PTO	—	—	—	ED	EC	EB	EA
After Reset	0	1	1	1	1	1	1	1

Bit	Symbol	Bit Name	Function	R/W
b0	EA	TRCIOA output disable bit ⁽¹⁾	0: Enable output 1: Disable output (The TRCIOA pin is used as a programmable I/O port.)	R/W
b1	EB	TRCIOB output disable bit ⁽¹⁾	0: Enable output 1: Disable output (The TRCIOB pin is used as a programmable I/O port.)	R/W
b2	EC	TRCIOC output disable bit ⁽¹⁾	0: Enable output 1: Disable output (The TRCIOC pin is used as a programmable I/O port.)	R/W
b3	ED	TRCIOD output disable bit ⁽¹⁾	0: Enable output 1: Disable output (The TRCIOD pin is used as a programmable I/O port.)	R/W
b4	—	Nothing is assigned. If necessary, set to 0. When read, the content is 1.		—
b5	—			
b6	—			
b7	PTO	$\overline{\text{INT0}}$ of pulse output forced cutoff signal input enabled bit	0: Pulse output forced cutoff input disabled 1: Pulse output forced cutoff input enabled (Bits EA, EB, EC, and ED are set to 1 (disable output) when "L" is applied to the $\overline{\text{INT0}}$ pin)	R/W

Note:

1. These bits are disabled for input pins set to the input capture function.

19.2.13 Timer RC Trigger Control Register (TRCADCR)

Address 0133h

Bit	b7	b6	b5	b4	b3	b2	b1	b0
Symbol	—	—	—	—	ADTRGDE	ADTRGCE	ADTRGBE	ADTRGAE
After Reset	0	0	0	0	0	0	0	0

Bit	Symbol	Bit Name	Function	R/W
b0	ADTRGAE	A/D trigger A enable bit	0: A/D trigger disabled 1: A/D trigger generated at compare match with registers TRC and TRCGRA	R/W
b1	ADTRGBE	A/D trigger B enable bit	0: A/D trigger disabled 1: A/D trigger generated at compare match with registers TRC and TRCGRB	R/W
b2	ADTRGCE	A/D trigger C enable bit	0: A/D trigger disabled 1: A/D trigger generated at compare match with registers TRC and TRCGRC	R/W
b3	ADTRGDE	A/D trigger D enable bit	0: A/D trigger disabled 1: A/D trigger generated at compare match with registers TRC and TRCGRD	R/W
b4	—	Nothing is assigned. If necessary, set to 0. When read, the content is 0.		—
b5	—			
b6	—			
b7	—			

19.2.14 Timer RB/RC Pin Select Register (TRBRCSR)

Address 0181h

Bit	b7	b6	b5	b4	b3	b2	b1	b0
Symbol	—	—	TRCCLKSEL1	—	—	—	TRBOSEL1	TRBOSEL0
After Reset	0	0	0	0	0	0	0	0

Bit	Symbol	Bit Name	Function	R/W
b0	TRBOSEL0	TRBO pin select bit	^{b1 b0} 0 0: P1_3 assigned 0 1: P3_1 assigned 1 0: Do not set. 1 1: TRBO pin not used	R/W
b1	TRBOSEL1			R/W
b2	—	Nothing is assigned. If necessary, set to 0. When read, the content is 0.		—
b3	—			
b4	—	Reserved bit	Set to 0.	R/W
b5	TRCCLKSEL1	TRCCLK pin select bit	0: TRCCLK pin not used 1: P3_3 assigned	R/W
b6	—	Reserved bit	Set to 0.	R/W
b7	—	Nothing is assigned. If necessary, set to 0. When read, the content is 0.		—

The TRBRCSR register selects which pin is assigned to the timer RB and timer RC I/O. To use the I/O pin for timer RB and timer RC, set this register.

Set bits TRBOSEL0 and TRBOSEL1 before setting the timer RB associated registers. Set bit TRCCLKSEL1 before setting the timer RC associated registers. Also, do not change the setting values of bits TRBOSEL0 and TRBOSEL1 during timer RB operation. Do not change the setting values of bit TRCCLKSEL1 during timer RC operation.

19.2.15 Timer RC Pin Select Register 0 (TRCPSR0)

Address 0182h

Bit	b7	b6	b5	b4	b3	b2	b1	b0
Symbol	—	—	—	TRCIOBSEL0	—	—	—	TRCIOASEL0
After Reset	0	0	0	0	0	0	0	0

Bit	Symbol	Bit Name	Function	R/W
b0	TRCIOASEL0	TRCIOA/TRCTRIG pin select bit	0: TRCIOA/TRCTRIG pin not used 1: P1_1 assigned	R/W
b1	—	Reserved bit	Set to 0.	R/W
b2	—			
b3	—	Nothing is assigned. If necessary, set to 0. When read, the content is 0.		—
b4	TRCIOBSEL0	TRCIOB pin select bit	0: TRCIOB pin not used 1: P1_2 assigned	R/W
b5	—	Reserved bit	Set to 0.	R/W
b6	—			
b7	—	Nothing is assigned. If necessary, set to 0. When read, the content is 0.		—

The TRCPSR0 register selects which pin is assigned to the timer RC I/O. To use the I/O pin for timer RC, set this register.

Set the TRCPSR0 register before setting the timer RC associated registers. Also, do not change the setting value in this register during timer RC operation.

19.2.16 Timer RC Pin Select Register 1 (TRCPSR1)

Address 0183h

Bit	b7	b6	b5	b4	b3	b2	b1	b0
Symbol	—	TRCIODSEL2	TRCIODSEL1	—	—	TRCIOSEL2	TRCIOSEL1	—
After Reset	0	0	0	0	0	0	0	0

Bit	Symbol	Bit Name	Function	R/W
b0	—	Reserved bit	Set to 0.	R/W
b1	TRCIOSEL1	TRCIO pin select bit	b2 b1 0 0: TRCIO pin not used 0 1: P3_4 assigned 1 1: P5_3 assigned Other than above: Do not set.	R/W
b2	TRCIOSEL2			R/W
b3	—	Nothing is assigned. If necessary, set to 0. When read, the content is 0.		—
b4	—	Reserved bit	Set to 0.	R/W
b5	TRCIODSEL1	TRCIOD pin select bit	b6 b5 0 0: TRCIOD pin not used 0 1: P3_5 assigned 1 1: P5_4 assigned Other than above: Do not set.	R/W
b6	TRCIODSEL2			R/W
b7	—	Nothing is assigned. If necessary, set to 0. When read, the content is 0.		—

The TRCPSR1 register selects which pin is assigned to the timer RC I/O. To use the I/O pin for timer RC, set this register.

Set the TRCPSR1 register before setting the timer RC associated registers. Also, do not change the setting value in this register during timer RC operation.

19.3 Common Items for Multiple Modes

19.3.1 Count Source

The method of selecting the count source is common to all modes.

Table 19.5 lists the Count Source Selection, and Figure 19.2 shows a Count Source Block Diagram.

Table 19.5 Count Source Selection

Count Source	Selection Method
f1, f2, f4, f8, f32	Count source selected using bits TCK2 to TCK0 in TRCCR1 register
fOCO40M fOCO-F	FRA00 bit in FRA0 register set to 1 (high-speed on-chip oscillator on) Bits TCK2 to TCK0 in TRCCR1 register are set to 110b (fOCO40M) Bits TCK2 to TCK0 in TRCCR1 register are set to 111b (fOCO-F)
External signal input to TRCCLK pin	Bits TCK2 to TCK0 in TRCCR1 register are set to 101b (count source is rising edge of external clock) and the corresponding direction bit in the corresponding direction register is set to 0 (input mode)

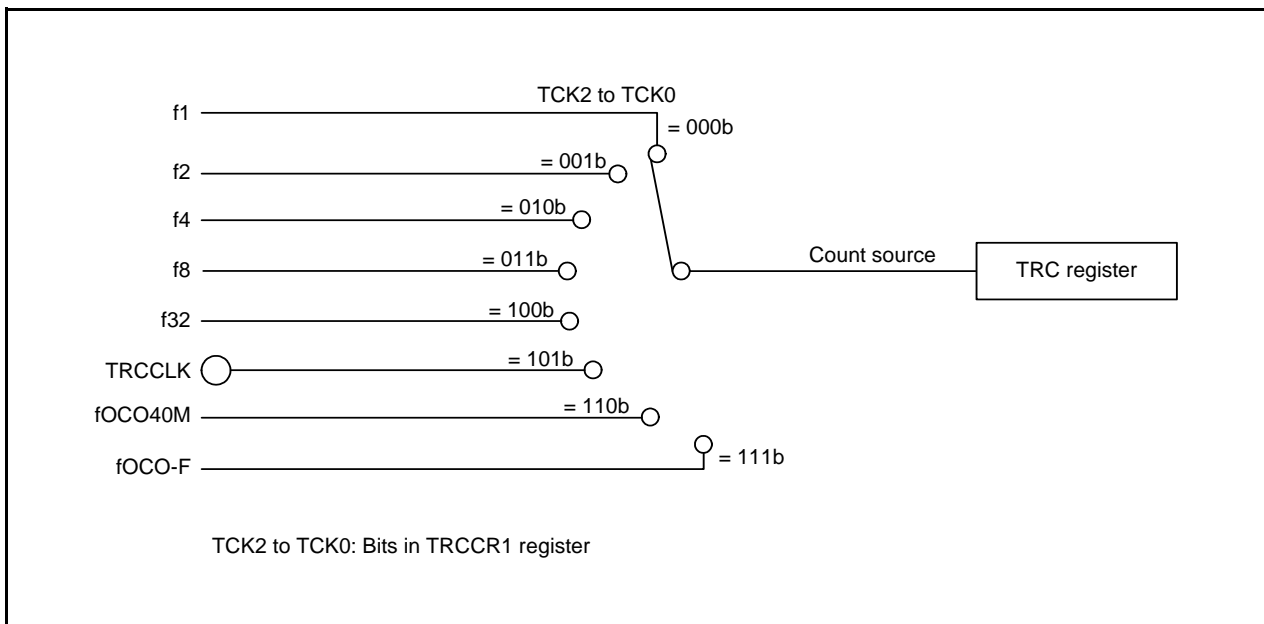

Figure 19.2 Count Source Block Diagram

The pulse width of the external clock input to the TRCCLK pin should be three cycles or more of the timer RC operation clock (refer to **Table 19.1 Timer RC Operation Clock**).

To select fOCO40M or fOCO-F as the count source, set the FRA00 bit in the FRA0 register set to 1 (high-speed on-chip oscillator on), and then set bits TCK2 to TCK0 in the TRCCR1 register to 110b (fOCO40M) or 111b (fOCO-F).

19.3.2 Buffer Operation

Bits BFC and BFD in the TRCMR register are used to select the TRCGRC or TRCGRD register as the buffer register for the TRCGRA or TRCGRB register.

- Buffer register for TRCGRA register: TRCGRC register
- Buffer register for TRCGRB register: TRCGRD register

Buffer operation differs depending on the mode.

Table 19.6 lists the Buffer Operation in Each Mode, Figure 19.3 shows the Buffer Operation for Input Capture Function, and Figure 19.4 shows the Buffer Operation for Output Compare Function.

Table 19.6 Buffer Operation in Each Mode

Function, Mode	Transfer Timing	Transfer Destination Register
Input capture function	Input capture signal input	Contents of TRCGRA (TRCGRB) register are transferred to buffer register
Output compare function	Compare match between TRC register and TRCGRA (TRCGRB) register	Contents of buffer register are transferred to TRCGRA (TRCGRB) register
PWM mode		
PWM2 mode	<ul style="list-style-type: none"> • Compare match between TRC register and TRCGRA register • TRCTR pin trigger input 	Contents of buffer register (TRCGRD) are transferred to TRCGRB register

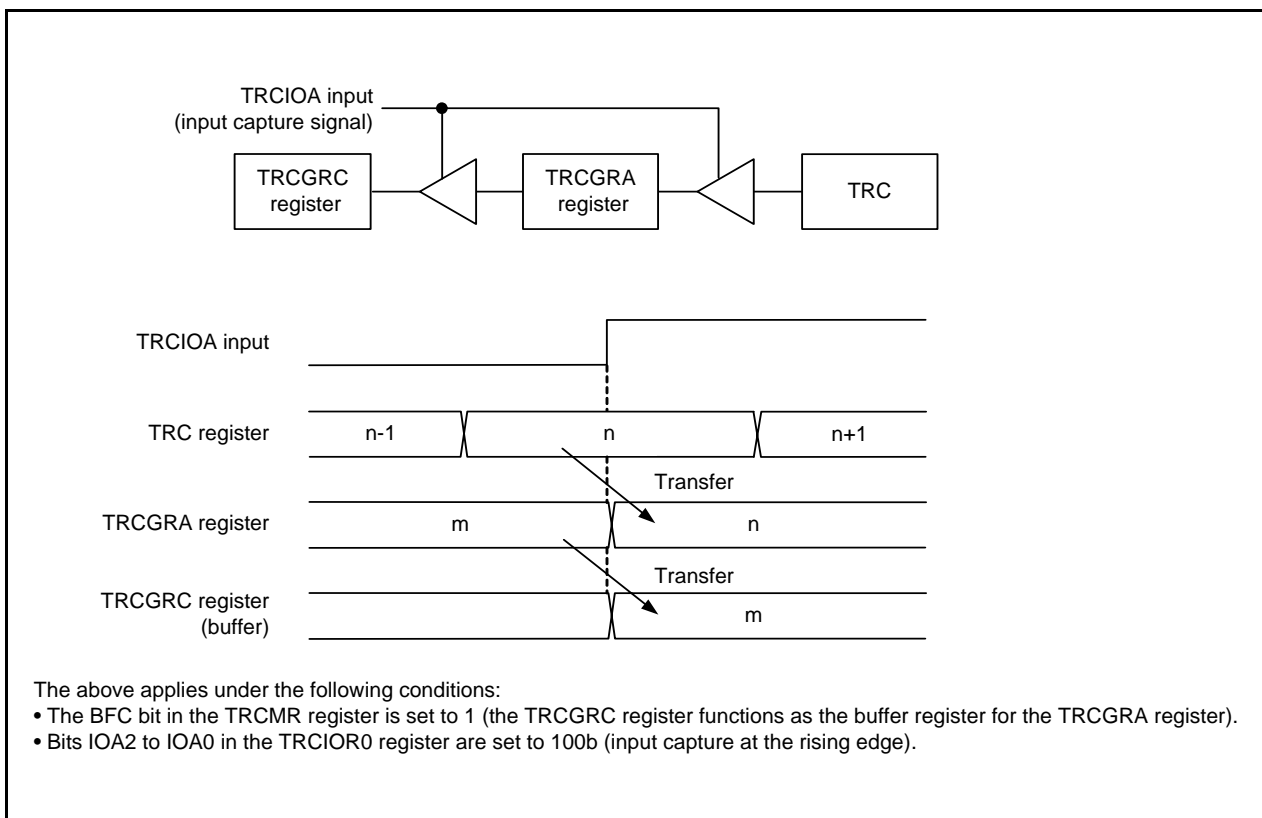

Figure 19.3 Buffer Operation for Input Capture Function

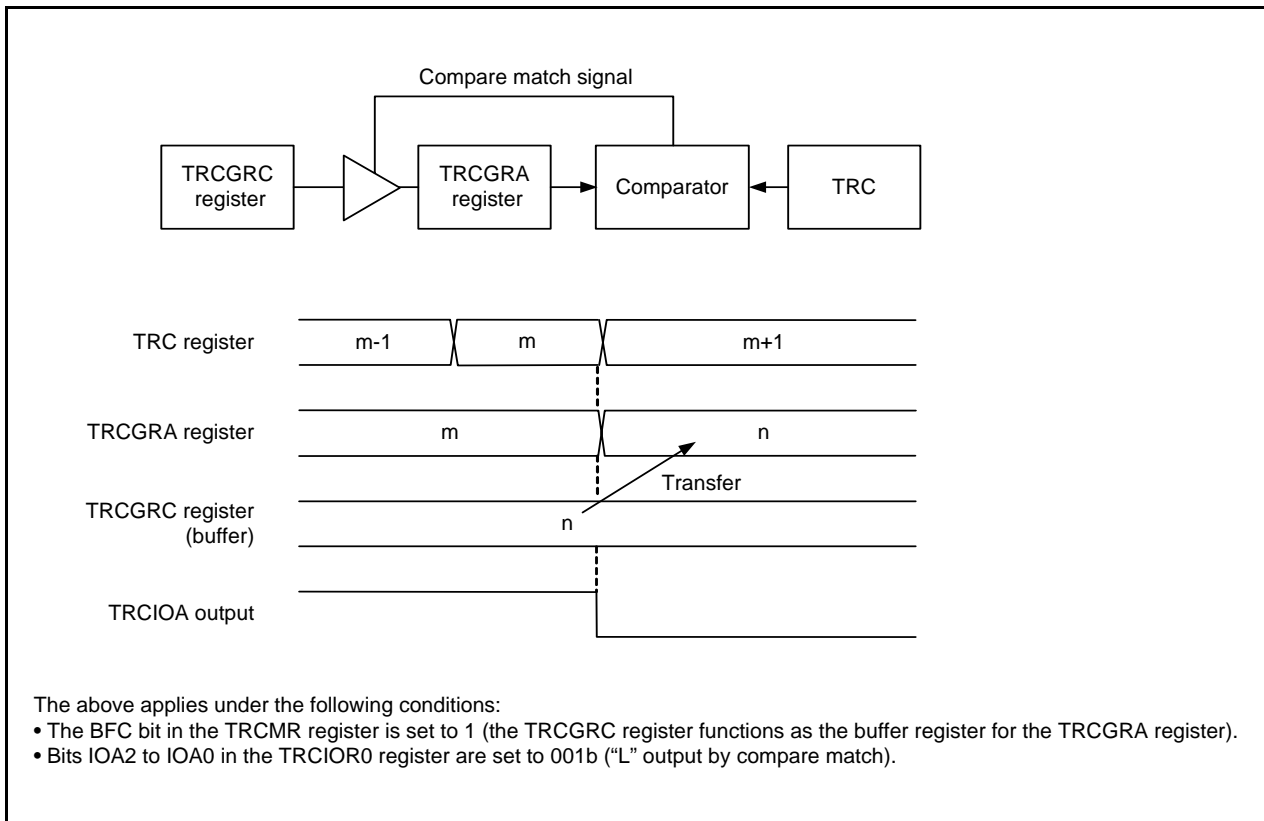

Figure 19.4 Buffer Operation for Output Compare Function

Make the following settings in timer mode.

- To use the TRCGRC register as the buffer register for the TRCGRA register:
Set the IOC2 bit in the TRCIOR1 register to the same value as the IOA2 bit in the TRCIOR0 register.
- To use the TRCGRD register as the buffer register for the TRCGRB register:
Set the IOD2 bit in the TRCIOR1 register to the same value as the IOB2 bit in the TRCIOR0 register.

The output compare function, PWM mode, or PWM2 mode, and the TRCGRC or TRCGRD register is functioning as a buffer register, the IMFC bit or IMFD bit in the TRCSR register is set to 1 when a compare match with the TRC register occurs.

The input capture function and the TRCGRC register or TRCGRD register is functioning as a buffer register, the IMFC bit or IMFD bit in the TRCSR register is set to 1 at the input edge of a signal input to the TRCIO pin or TRCIOD pin.

19.3.3 Digital Filter

The input to TRCTR_j or TRCIO_j (j = A, B, C, or D) is sampled, and the level is considered to be determined when three matches occur. The digital filter function and sampling clock are selected using the TRCDF register. Figure 19.5 shows a Digital Filter Block Diagram.

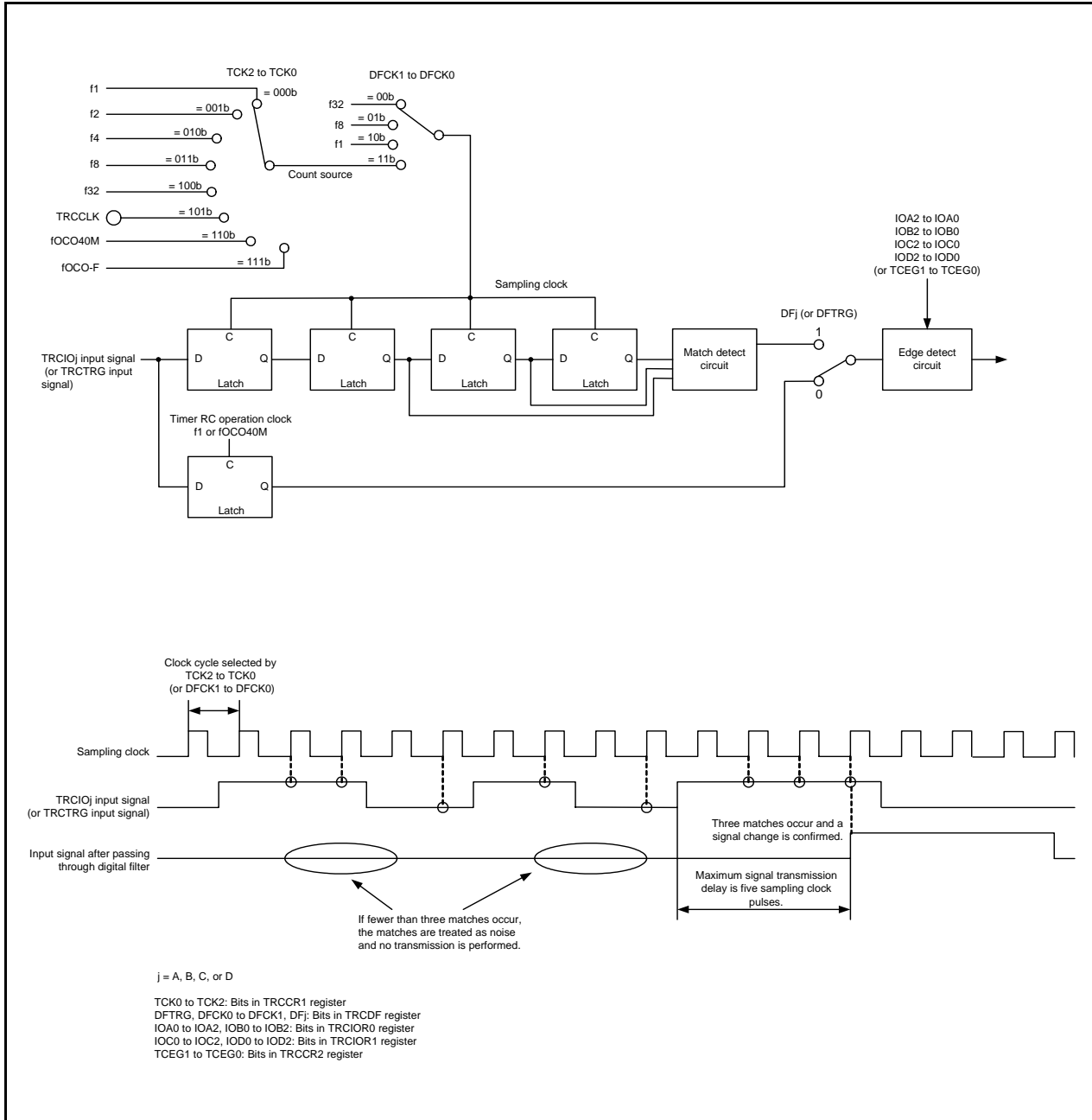

Figure 19.5 Digital Filter Block Diagram

19.3.4 Forced Cutoff of Pulse Output

When using the timer mode's output compare function, the PWM mode, or the PWM2 mode, pulse output from the TRCIOj (j = A, B, C, or D) output pin can be forcibly cut off and the TRCIOj pin set to function as a programmable I/O port by means of input to the $\overline{\text{INT0}}$ pin.

A pin used for output by the timer mode's output compare function, the PWM mode, or the PWM2 mode can be set to function as the timer RC output pin by setting the Ej bit in the TRCOER register to 0 (timer RC output enabled). If "L" is input to the $\overline{\text{INT0}}$ pin while the PTO bit in the TRCOER register is set to 1 (pulse output forced cutoff signal input $\overline{\text{INT0}}$ enabled), bits EA, EB, EC, and ED in the TRCOER register are all set to 1 (timer RC output disabled, TRCIOj output pin functions as the programmable I/O port). When one or two cycles of the timer RC operation clock after "L" input to the $\overline{\text{INT0}}$ pin (refer to **Table 19.1 Timer RC Operation Clock**) has elapsed, the TRCIOj output pin becomes a programmable I/O port.

Make the following settings to use this function:

- Set the pin state following forced cutoff of pulse output (high impedance (input), "L" output, or "H" output). (Refer to **7. I/O Ports**.)
- Set the INT0EN bit in the INTEN register to 1 ($\overline{\text{INT0}}$ input enabled) and the INT0PL bit to 0 (one edge), and set the POL bit in the INTOIC register to 0 (falling edge selected).
- Set the PD4_5 bit in the PD4 register to 0 (input mode).
- Select the $\overline{\text{INT0}}$ digital filter by bits INT0F1 to INT0F0 in the INTF register.
- Set the PTO bit in the TRCOER register to 1 (pulse output forced cutoff signal input $\overline{\text{INT0}}$ enabled).

The IR bit in the INTOIC register is set to 1 (interrupt request) in accordance with the setting of the POL bit in the INTOIC register and the INT0PL bit in the INTEN register and a change in the $\overline{\text{INT0}}$ pin input (refer to **11.8 Notes on Interrupts**).

For details on interrupts, refer to **11. Interrupts**.

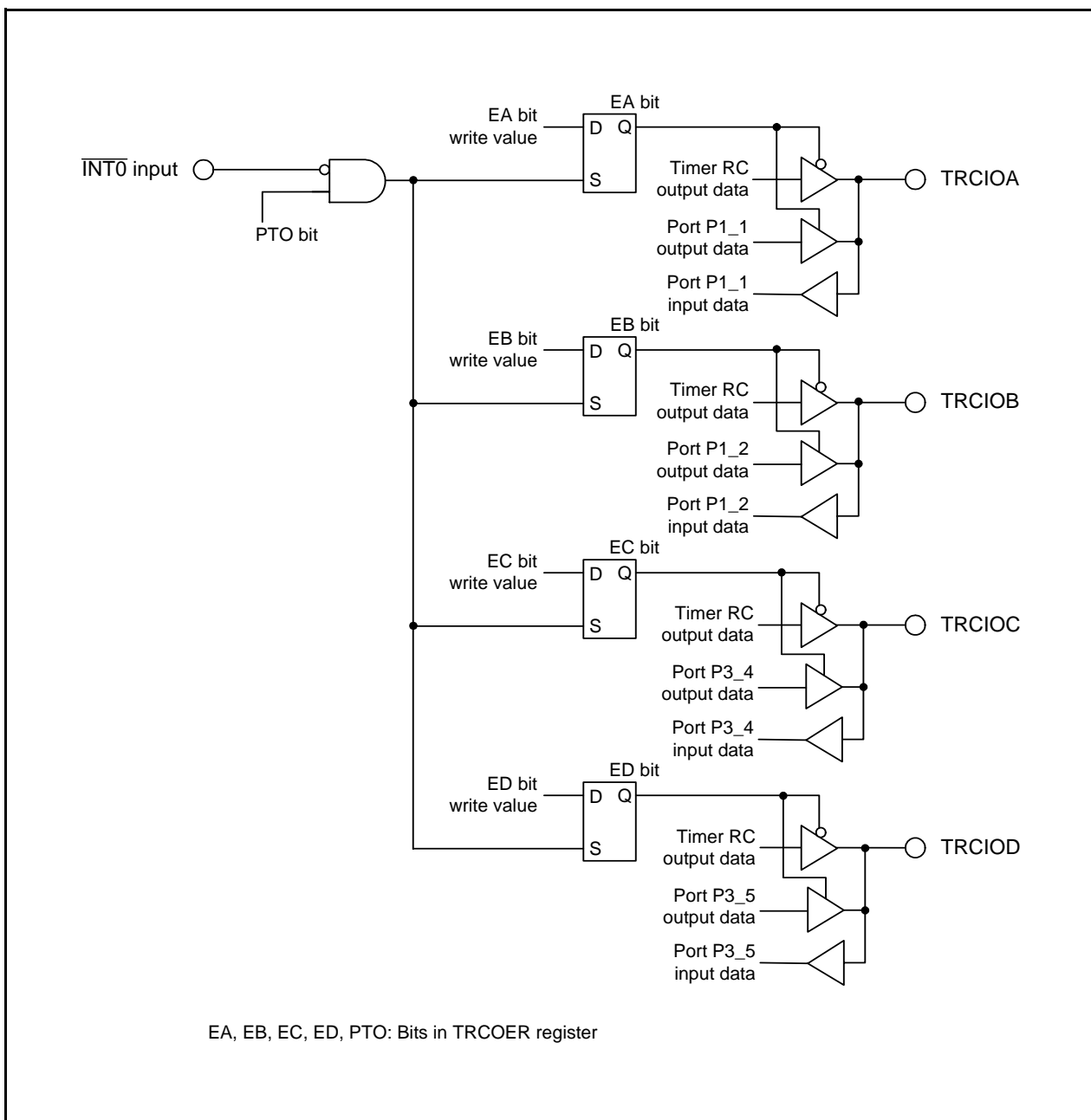

Figure 19.6 Forced Cutoff of Pulse Output

19.4 Timer Mode (Input Capture Function)

This function measures the width or period of an external signal. An external signal input to the TRCIO_j (j = A, B, C, or D) pin acts as a trigger for transferring the contents of the TRC register (counter) to the TRCGR_j register (input capture). The input capture function, or any other mode or function, can be selected for each individual pin. The TRCGRA register can also select fOCO128 signal as input-capture trigger input.

Table 19.7 lists the Specifications of Input Capture Function, Figure 19.7 shows a Block Diagram of Input Capture Function, Table 19.8 lists the Functions of TRCGR_j Register when Using Input Capture Function, and Figure 19.8 shows an Operating Example of Input Capture Function.

Table 19.7 Specifications of Input Capture Function

Item	Specification
Count source	f1, f2, f4, f8, f32, fOCO40M, fOCO-F External signal (rising edge) input to TRCCLK pin
Count operation	Increment
Count period	<ul style="list-style-type: none"> The CCLR bit in the TRCCR1 register is set to 0 (free running operation): $1/fk \times 65,536$ fk: Count source frequency The CCLR bit in the TRCCR1 register is set to 1 (TRC register set to 0000h at TRCGRA input capture): $1/fk \times (n + 1)$ n: TRCGRA register setting value
Count start condition	1 (count starts) is written to the TSTART bit in the TRCMR register.
Count stop condition	0 (count stops) is written to the TSTART bit in the TRCMR register. The TRC register retains a value before count stops.
Interrupt request generation timing	<ul style="list-style-type: none"> Input capture (valid edge of TRCIO_j input or fOCO128 signal edge) The TRC register overflows.
TRCIOA, TRCIOB, TRCIOC, and TRCIOD pin functions	Programmable I/O port or input capture input (selectable individually for each pin)
INT0 pin function	Programmable I/O port or INT0 interrupt input
Read from timer	The count value can be read by reading TRC register.
Write to timer	The TRC register can be written to.
Selectable functions	<ul style="list-style-type: none"> Input capture input pin selection One or more of pins TRCIOA, TRCIOB, TRCIOC, and TRCIOD Input capture input valid edge selection Rising edge, falling edge, or both rising and falling edges Buffer operation (Refer to 19.3.2 Buffer Operation.) Digital filter (Refer to 19.3.3 Digital Filter.) Timing for setting the TRC register to 0000h Overflow or input capture Input-capture trigger selected fOCO128 can be selected for input-capture trigger input of the TRCGRA register.

j = A, B, C, or D

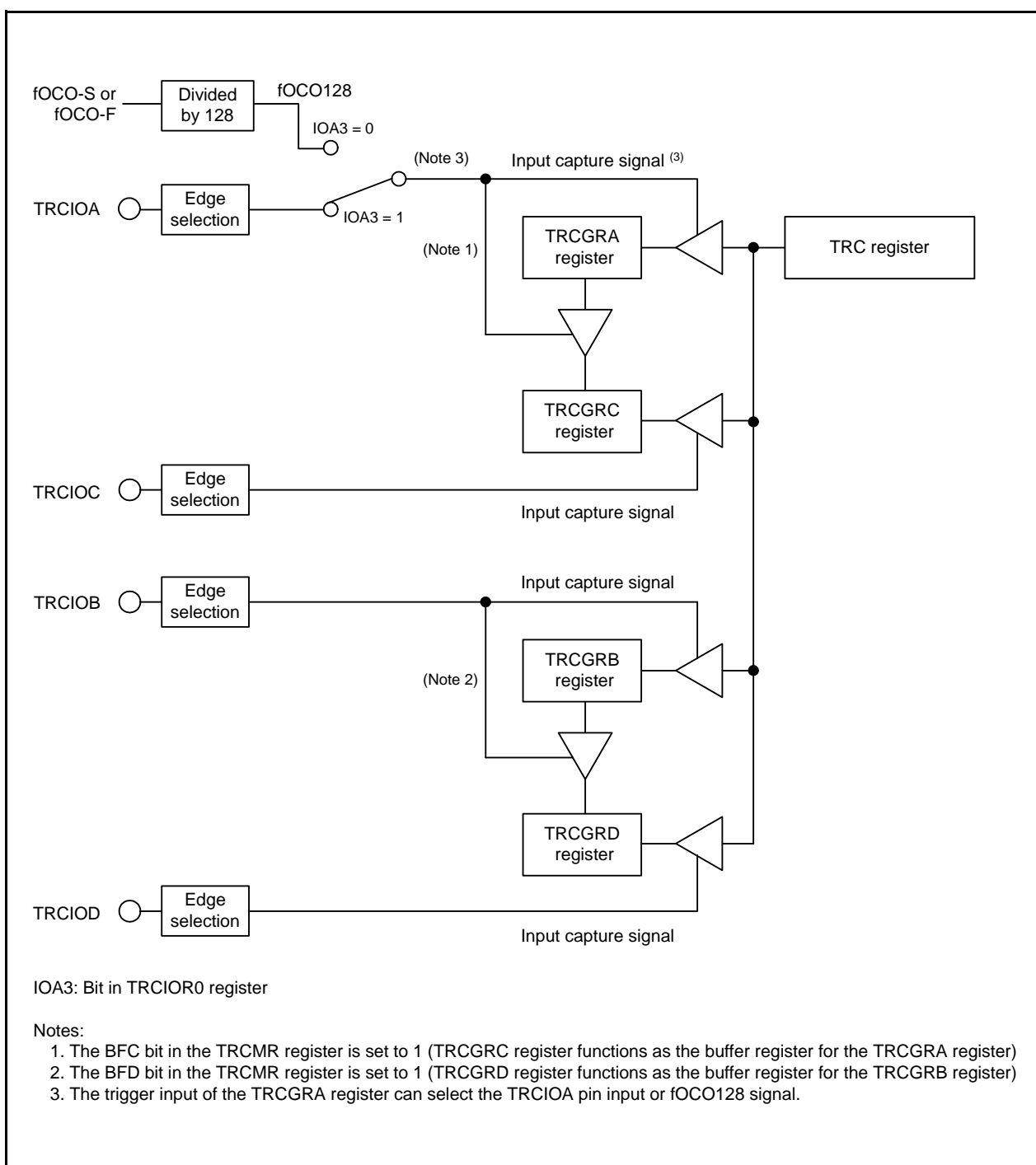

Figure 19.7 Block Diagram of Input Capture Function

19.4.1 Timer RC I/O Control Register 0 (TRCIOR0) for Input Capture Function

Address 0124h

Bit	b7	b6	b5	b4	b3	b2	b1	b0
Symbol	—	IOB2	IOB1	IOB0	IOA3	IOA2	IOA1	IOA0
After Reset	1	0	0	0	1	0	0	0

Bit	Symbol	Bit Name	Function	R/W
b0	IOA0	TRCGRA control bit	^{b1 b0} 0 0: Input capture to the TRCGRA register at the rising edge 0 1: Input capture to the TRCGRA register at the falling edge 1 0: Input capture to the TRCGRA register at both edges 1 1: Do not set.	R/W
b1	IOA1			R/W
b2	IOA2	TRCGRA mode select bit ⁽¹⁾	Set to 1 (input capture) in the input capture function.	R/W
b3	IOA3	TRCGRA input capture input switch bit ⁽³⁾	0: fOCO128 signal 1: TRCIOA pin input	R/W
b4	IOB0	TRCGRB control bit	^{b5 b4} 0 0: Input capture to the TRCGRB register at the rising edge 0 1: Input capture to the TRCGRB register at the falling edge 1 0: Input capture to the TRCGRB register at both edges 1 1: Do not set.	R/W
b5	IOB1			R/W
b6	IOB2	TRCGRB mode select bit ⁽²⁾	Set to 1 (input capture) in the input capture function.	R/W
b7	—	Nothing is assigned. If necessary, set to 0. When read, the content is 1.		—

Notes:

1. When the BFC bit in the TRCMR register is set to 1 (buffer register of TRCGRA register), set the IOC2 bit in the TRCIOR1 register to the same value as the IOA2 bit in the TRCIOR0 register.
2. When the BFD bit in the TRCMR register is set to 1 (buffer register of TRCGRB register), set the IOD2 bit in the TRCIOR1 register to the same value as the IOB2 bit in the TRCIOR0 register.
3. The IOA3 bit is enabled when the IOA2 bit is set to 1 (input capture function).

19.4.2 Timer RC I/O Control Register 1 (TRCIOR1) for Input Capture Function

Address 0125h

Bit	b7	b6	b5	b4	b3	b2	b1	b0
Symbol	IOD3	IOD2	IOD1	IOD0	IOC3	IOC2	IOC1	IOC0
After Reset	1	0	0	0	1	0	0	0

Bit	Symbol	Bit Name	Function	R/W
b0	IOC0	TRCGRC control bit	^{b1 b0} 0 0: Input capture to the TRCGRC register at the rising edge 0 1: Input capture to the TRCGRC register at the falling edge 1 0: Input capture to the TRCGRC register at both edges 1 1: Do not set.	R/W
b1	IOC1			R/W
b2	IOC2	TRCGRC mode select bit ⁽¹⁾	Set to 1 (input capture) in the input capture function.	R/W
b3	IOC3	TRCGRC register function select bit	Set to 1.	R/W
b4	IOD0	TRCGRD control bit	^{b5 b4} 0 0: Input capture to the TRCGRD register at the rising edge 0 1: Input capture to the TRCGRD register at the falling edge 1 0: Input capture to the TRCGRD register at both edges 1 1: Do not set.	R/W
b5	IOD1			R/W
b6	IOD2	TRCGRD mode select bit ⁽²⁾	Set to 1 (input capture) in the input capture function.	R/W
b7	IOD3	TRCGRD register function select bit	Set to 1.	R/W

Notes:

- When the BFC bit in the TRCMR register is set to 1 (buffer register of TRCGRA register), set the IOC2 bit in the TRCIOR1 register to the same value as the IOA2 bit in the TRCIOR0 register.
- When the BFD bit in the TRCMR register is set to 1 (buffer register of TRCGRB register), set the IOD2 bit in the TRCIOR1 register to the same value as the IOB2 bit in the TRCIOR0 register.

Table 19.8 Functions of TRCGRj Register when Using Input Capture Function

Register	Setting	Register Function	Input Capture Input Pin
TRCGRA	–	General register. Can be used to read the TRC register value at input capture.	TRCIOA
TRCGRB			TRCIOB
TRCGRC	BFC = 0	General register. Can be used to read the TRC register value at input capture.	TRCIOC
TRCGRD	BFD = 0		TRCIOD
TRCGRC	BFC = 1	Buffer registers. Can be used to hold transferred value from the general register. (Refer to 19.3.2 Buffer Operation.)	TRCIOA
TRCGRD	BFD = 1		TRCIOB

j = A, B, C, or D

BFC, BFD: Bits in TRCMR register

19.4.3 Operating Example

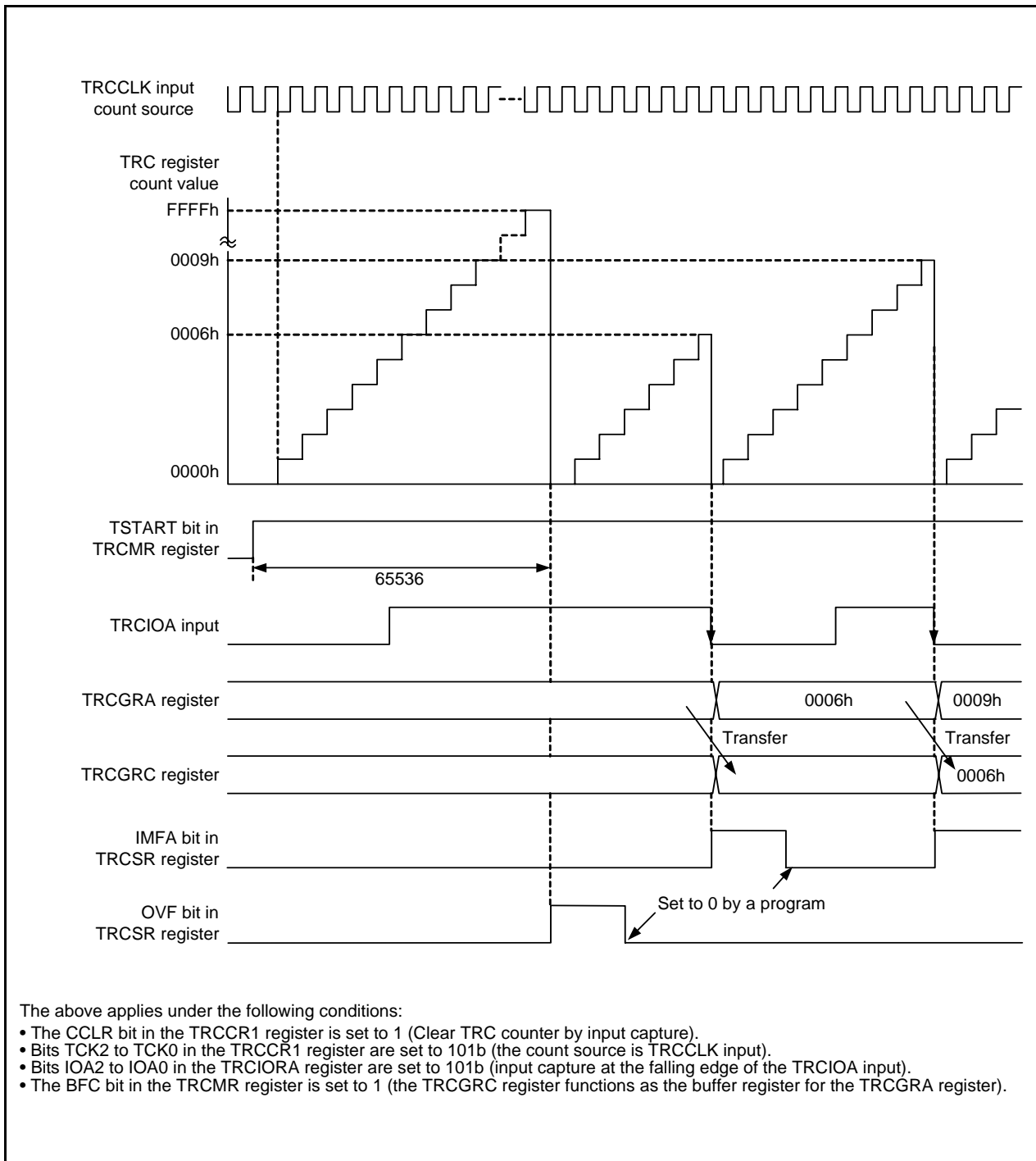

Figure 19.8 Operating Example of Input Capture Function

19.5 Timer Mode (Output Compare Function)

This function detects when the contents of the TRC register (counter) and the TRCGRj register (j = A, B, C, or D) match (compare match). When a match occurs a signal is output from the TRCIOj pin at a given level. The output compare function, or other mode or function, can be selected for each individual pin.

Table 19.9 lists the Specifications of Output Compare Function, Figure 19.9 shows a Block Diagram of Output Compare Function, Table 19.10 lists the Functions of TRCGRj Register when Using Output Compare Function, and Figure 19.10 shows an Operating Example of Output Compare Function.

Table 19.9 Specifications of Output Compare Function

Item	Specification
Count source	f1, f2, f4, f8, f32, fOCO40M, fOCO-F External signal (rising edge) input to TRCCLK pin
Count operation	Increment
Count period	<ul style="list-style-type: none"> The CCLR bit in the TRCCR1 register is set to 0 (free running operation): $1/fk \times 65,536$ fk: Count source frequency The CCLR bit in the TRCCR1 register is set to 1 (TRC register set to 0000h at TRCGRA compare match): $1/fk \times (n + 1)$ n: TRCGRA register setting value
Waveform output timing	Compare match
Count start condition	1 (count starts) is written to the TSTART bit in the TRCMR register.
Count stop condition	<ul style="list-style-type: none"> When the CSEL bit in the TRCCR2 register is set to 0 (count continues after compare match with TRCGRA). 0 (count stops) is written to the TSTART bit in the TRCMR register. The output compare output pin retains output level before count stops, the TRC register retains a value before count stops. When the CSEL bit in the TRCCR2 register is set to 1 (count stops at compare match with TRCGRA register). The count stops at the compare match with the TRCGRA register. The output compare output pin retains the level after the output is changed by the compare match.
Interrupt request generation timing	<ul style="list-style-type: none"> Compare match (contents of registers TRC and TRCGRj match) The TRC register overflows.
TRCIOA, TRCIOB, TRCIOC, and TRCIOD pin functions	Programmable I/O port or output compare output (Selectable individually for each pin)
INT0 pin function	Programmable I/O port, pulse output forced cutoff signal input, or INT0 interrupt input
Read from timer	The count value can be read by reading the TRC register.
Write to timer	The TRC register can be written to.
Selectable functions	<ul style="list-style-type: none"> Output compare output pin selection One or more of pins TRCIOA, TRCIOB, TRCIOC, and TRCIOD Compare match output level selection “L” output, “H” output, or toggle output Initial output level selection Sets output level for period from count start to compare match Timing for setting the TRC register to 0000h Overflow or compare match with the TRCGRA register Buffer operation (Refer to 19.3.2 Buffer Operation.) Pulse output forced cutoff signal input (Refer to 19.3.4 Forced Cutoff of Pulse Output.) Can be used as an internal timer by disabling timer RC output Changing output pins for registers TRCGRC and TRCGRD TRCGRC can be used for output control of the TRCIOA pin and TRCGRD can be used for output control of the TRCIOB pin. A/D trigger generation

j = A, B, C, or D

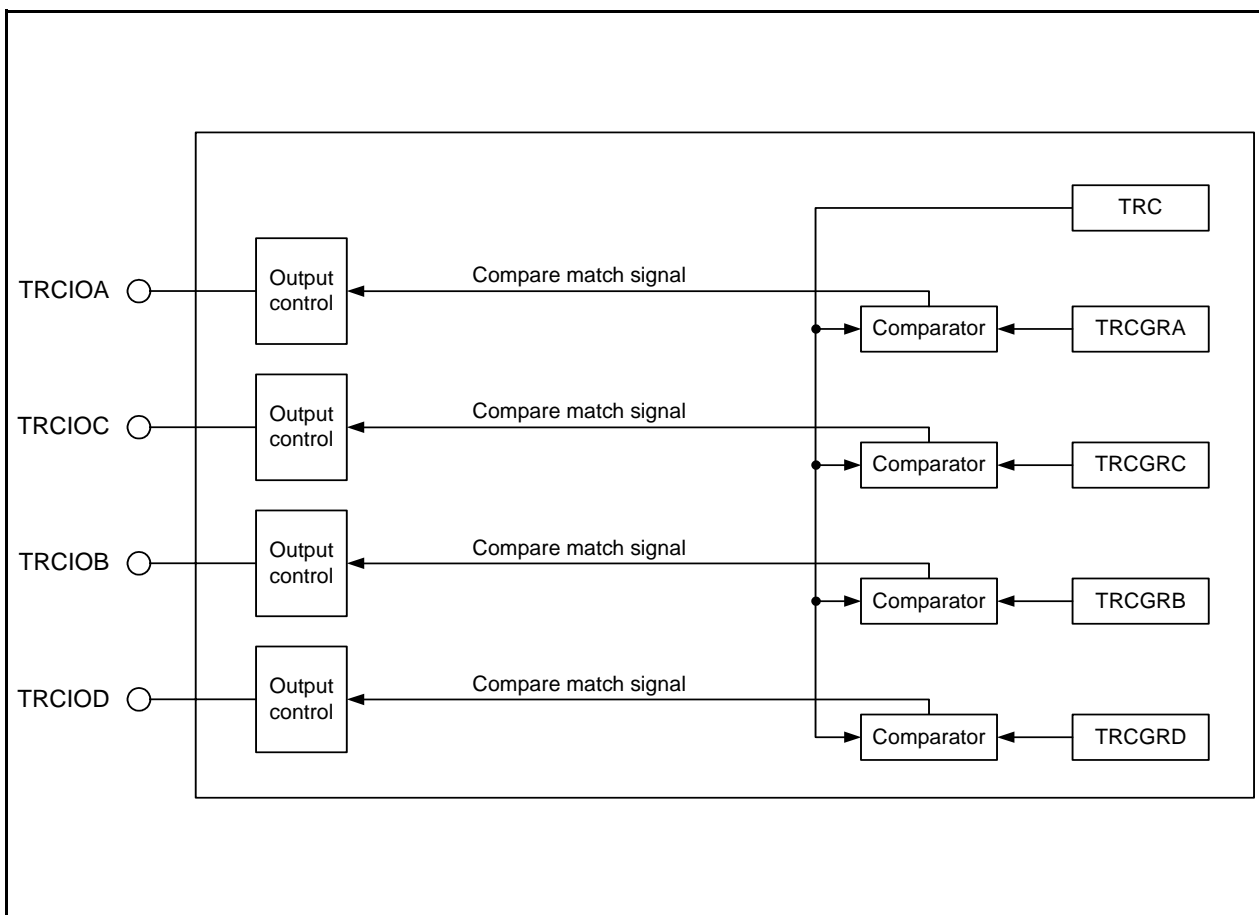

Figure 19.9 Block Diagram of Output Compare Function

19.5.1 Timer RC Control Register 1 (TRCCR1) for Output Compare Function

Address 0121h

Bit	b7	b6	b5	b4	b3	b2	b1	b0
Symbol	CCLR	TCK2	TCK1	TCK0	TOD	TOC	TOB	TOA
After Reset	0	0	0	0	0	0	0	0

Bit	Symbol	Bit Name	Function	R/W
b0	TOA	TRCIOA output level select bit (1, 2)	0: Initial output "L" 1: Initial output "H"	R/W
b1	TOB	TRCIOB output level select bit (1, 2)		R/W
b2	TOC	TRCIOC output level select bit (1, 2)		R/W
b3	TOD	TRCIOD output level select bit (1, 2)		R/W
b4	TCK0	Count source select bit (1)		b6 b5 b4 0 0 0: f1 0 0 1: f2 0 1 0: f4 0 1 1: f8 1 0 0: f32 1 0 1: TRCCLK input rising edge 1 1 0: fOCO40M 1 1 1: fOCO-F (3)
b5	TCK1		R/W	
b6	TCK2		R/W	
b7	CCLR	TRC counter clear select bit	0: Disable clear (free-running operation) 1: Clear by compare match in the TRCGRA register	R/W

Notes:

1. Set to these bits when the TSTART bit in the TRCMR register is set to 0 (count stops).
2. If the pin function is set for waveform output (refer to **7.5 Port Settings**), the initial output level is output when the TRCCR1 register is set.
3. To select fOCO-F, set it to the clock frequency higher than the CPU clock frequency.

Table 19.10 Functions of TRCGRj Register when Using Output Compare Function

Register	Setting	Register Function	Output Compare Output Pin
TRCGRA	–	General register. Write a compare value to one of these registers.	TRCIOA
TRCGRB			TRCIOB
TRCGRC	BFC = 0	General register. Write a compare value to one of these registers.	TRCIOC
TRCGRD	BFD = 0		TRCIOD
TRCGRC	BFC = 1	Buffer register. Write the next compare value to one of these registers. (Refer to 19.3.2 Buffer Operation .)	TRCIOA
TRCGRD	BFD = 1		TRCIOB

j = A, B, C, or D

BFC, BFD: Bits in TRCMR register

19.5.2 Timer RC I/O Control Register 0 (TRCIOR0) for Output Compare Function

Address 0124h

Bit	b7	b6	b5	b4	b3	b2	b1	b0
Symbol	—	IOB2	IOB1	IOB0	IOA3	IOA2	IOA1	IOA0
After Reset	1	0	0	0	1	0	0	0

Bit	Symbol	Bit Name	Function	R/W
b0	IOA0	TRCGRA control bit	^{b1 b0} 0 0: Disable pin output by compare match (TRCIOA pin functions as the programmable I/O port) 0 1: "L" output by compare match in the TRCGRA register 1 0: "H" output by compare match in the TRCGRA register 1 1: Toggle output by compare match in the TRCGRA register	R/W
b1	IOA1			R/W
b2	IOA2	TRCGRA mode select bit ⁽¹⁾	Set to 0 (output compare) in the output compare function.	R/W
b3	IOA3	TRCGRA input capture input switch bit	Set to 1.	R/W
b4	IOB0	TRCGRB control bit	^{b5 b4} 0 0: Disable pin output by compare match (TRCIOB pin functions as the programmable I/O port) 0 1: "L" output by compare match in the TRCGRB register 1 0: "H" output by compare match in the TRCGRB register 1 1: Toggle output by compare match in the TRCGRB register	R/W
b5	IOB1			R/W
b6	IOB2	TRCGRB mode select bit ⁽²⁾	Set to 0 (output compare) in the output compare function.	R/W
b7	—	Nothing is assigned. If necessary, set to 0. When read, the content is 1.		—

Notes:

- When the BFC bit in the TRCMR register is set to 1 (buffer register of TRCGRA register), set the IOC2 bit in the TRCIOR1 register to the same value as the IOA2 bit in the TRCIOR0 register.
- When the BFD bit in the TRCMR register is set to 1 (buffer register of TRCGRB register), set the IOD2 bit in the TRCIOR1 register to the same value as the IOB2 bit in the TRCIOR0 register.

19.5.3 Timer RC I/O Control Register 1 (TRCIOR1) for Output Compare Function

Address 0125h

Bit	b7	b6	b5	b4	b3	b2	b1	b0
Symbol	IOD3	IOD2	IOD1	IOD0	IOC3	IOC2	IOC1	IOC0
After Reset	1	0	0	0	1	0	0	0

Bit	Symbol	Bit Name	Function	R/W
b0	IOC0	TRCGRC control bit	b1 b0 0 0: Disable pin output by compare match 0 1: "L" output by compare match in the TRCGRC register 1 0: "H" output by compare match in the TRCGRC register 1 1: Toggle output by compare match in the TRCGRC register	R/W
b1	IOC1			R/W
b2	IOC2	TRCGRC mode select bit ⁽¹⁾	Set to 0 (output compare) in the output compare function.	R/W
b3	IOC3	TRCGRC register function select bit	0: TRCIOA output register 1: General register or buffer register	R/W
b4	IOD0	TRCGRD control bit	b5 b4 0 0: Disable pin output by compare match 0 1: "L" output by compare match in the TRCGRD register 1 0: "H" output by compare match in the TRCGRD register 1 1: Toggle output by compare match in the TRCGRD register	R/W
b5	IOD1			R/W
b6	IOD2	TRCGRD mode select bit ⁽²⁾	Set to 0 (output compare) in the output compare function.	R/W
b7	IOD3	TRCGRD register function select bit	0: TRCIOB output register 1: General register or buffer register	R/W

Notes:

- When the BFC bit in the TRCMR register is set to 1 (buffer register of TRCGRA register), set the IOC2 bit in the TRCIOR1 register to the same value as the IOA2 bit in the TRCIOR0 register.
- When the BFD bit in the TRCMR register is set to 1 (buffer register of TRCGRB register), set the IOD2 bit in the TRCIOR1 register to the same value as the IOB2 bit in the TRCIOR0 register.

19.5.4 Timer RC Control Register 2 (TRCCR2) for Output Compare Function

Address 0130h

Bit	b7	b6	b5	b4	b3	b2	b1	b0
Symbol	TCEG1	TCEG0	CSEL	—	—	POLD	POLC	POLB
After Reset	0	0	0	1	1	0	0	0

Bit	Symbol	Bit Name	Function	R/W
b0	POLB	PWM mode output level control bit B ⁽¹⁾	0: TRCIOB output level selected as "L" active 1: TRCIOB output level selected as "H" active	R/W
b1	POLC	PWM mode output level control bit C ⁽¹⁾	0: TRCIOC output level selected as "L" active 1: TRCIOC output level selected as "H" active	R/W
b2	POLD	PWM mode output level control bit D ⁽¹⁾	0: TRCIOD output level selected as "L" active 1: TRCIOD output level selected as "H" active	R/W
b3	—	Nothing is assigned. If necessary, set to 0. When read, the content is 1.		—
b4	—			
b5	CSEL	TRC count operation select bit ⁽²⁾	0: Count continues at compare match with the TRCGRA register 1: Count stops at compare match with the TRCGRA register	R/W
b6	TCEG0	TRCTRG input edge select bit ⁽³⁾	^{b7 b6} 0 0: Disable the trigger input from the TRCTRG pin 0 1: Rising edge selected 1 0: Falling edge selected 1 1: Both edges selected	R/W
b7	TCEG1			R/W

Notes:

1. Enabled when in PWM mode.
2. Enabled when in the output compare function, PWM mode, or PWM2 mode. For notes on PWM2 mode, refer to **19.9.6 TRCMR Register in PWM2 Mode**.
3. Enabled when in PWM2 mode.

19.5.5 Operating Example

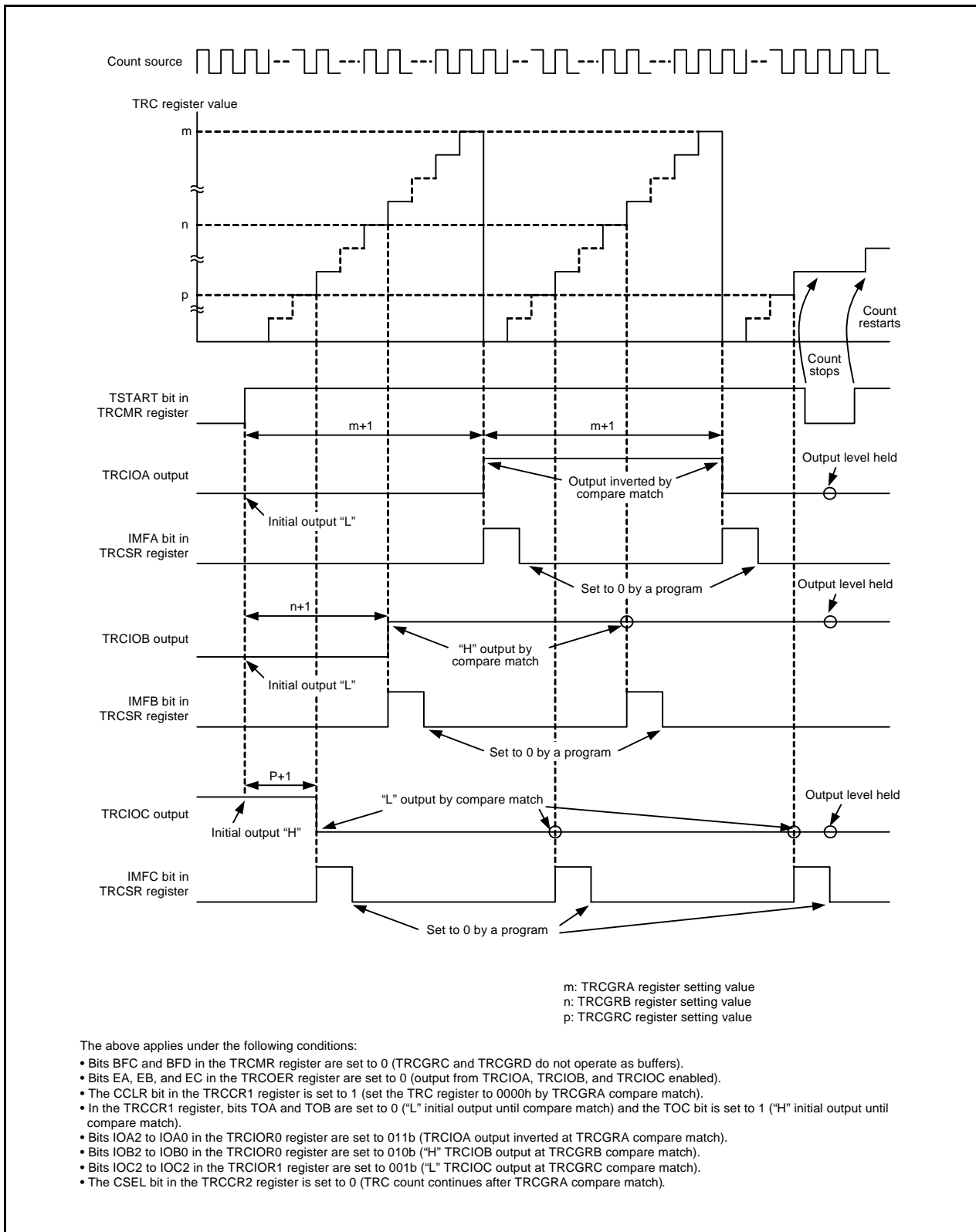

Figure 19.10 Operating Example of Output Compare Function

19.5.6 Changing Output Pins in Registers TRCGRC and TRCGRD

The TRCGRC register can be used for output control of the TRCIOA pin, and the TRCGRD register can be used for output control of the TRCIOB pin. Therefore, each pin output can be controlled as follows:

- TRCIOA output is controlled by the values in registers TRCGRA and TRCGRC.
- TRCIOB output is controlled by the values in registers TRCGRB and TRCGRD.

Change output pins in registers TRCGRC and TRCGRD as follows:

- Set the IOC3 bit in the TRCIOR1 register to 0 (TRCIOA output register) and set the IOD3 bit to 0 (TRCIOB output register).
- Set bits BFC and BFD in the TRCMR register to 0 (general register).
- Set different values in registers TRCGRC and TRCGRA. Also, set different values in registers TRCGRD and TRCGRB.

Figure 19.12 shows an Operating Example When TRCGRC Register is Used for Output Control of TRCIOA Pin and TRCGRD Register is Used for Output Control of TRCIOB Pin.

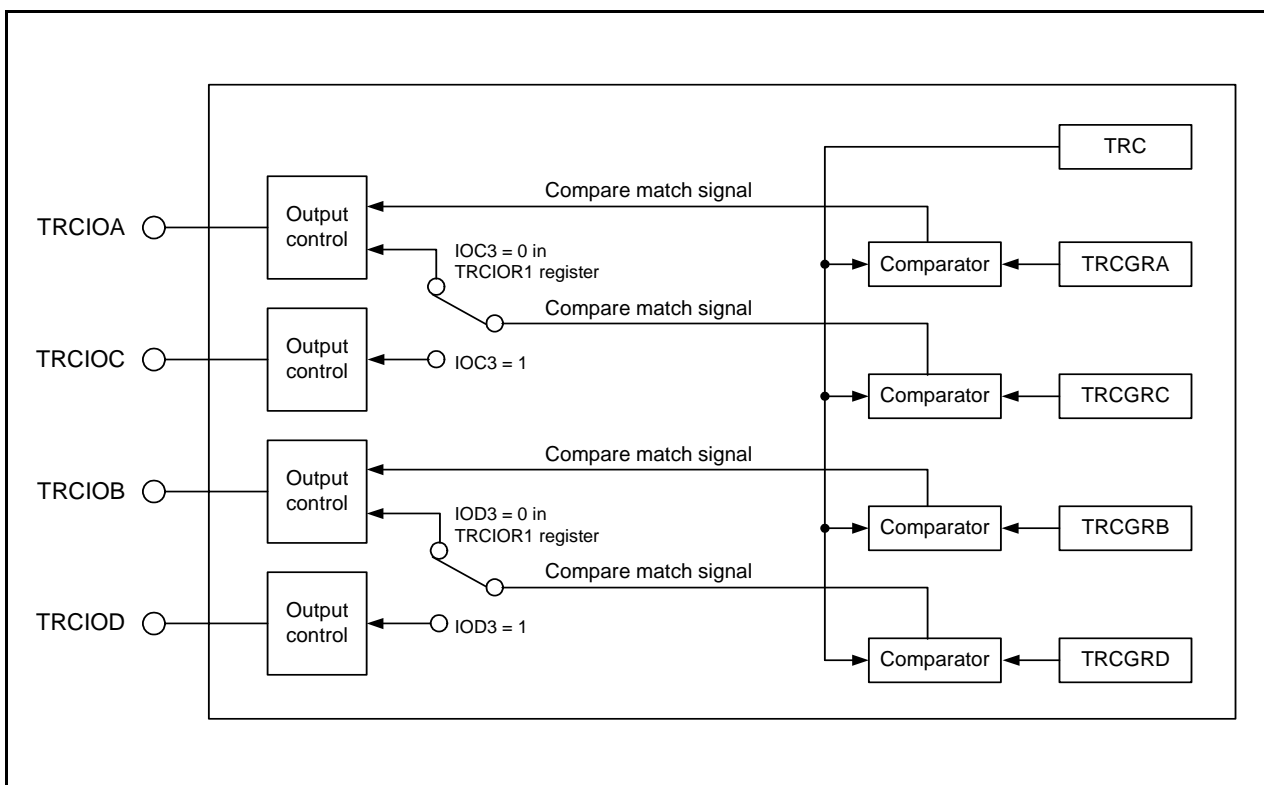

Figure 19.11 Changing Output Pins in Registers TRCGRC and TRCGRD

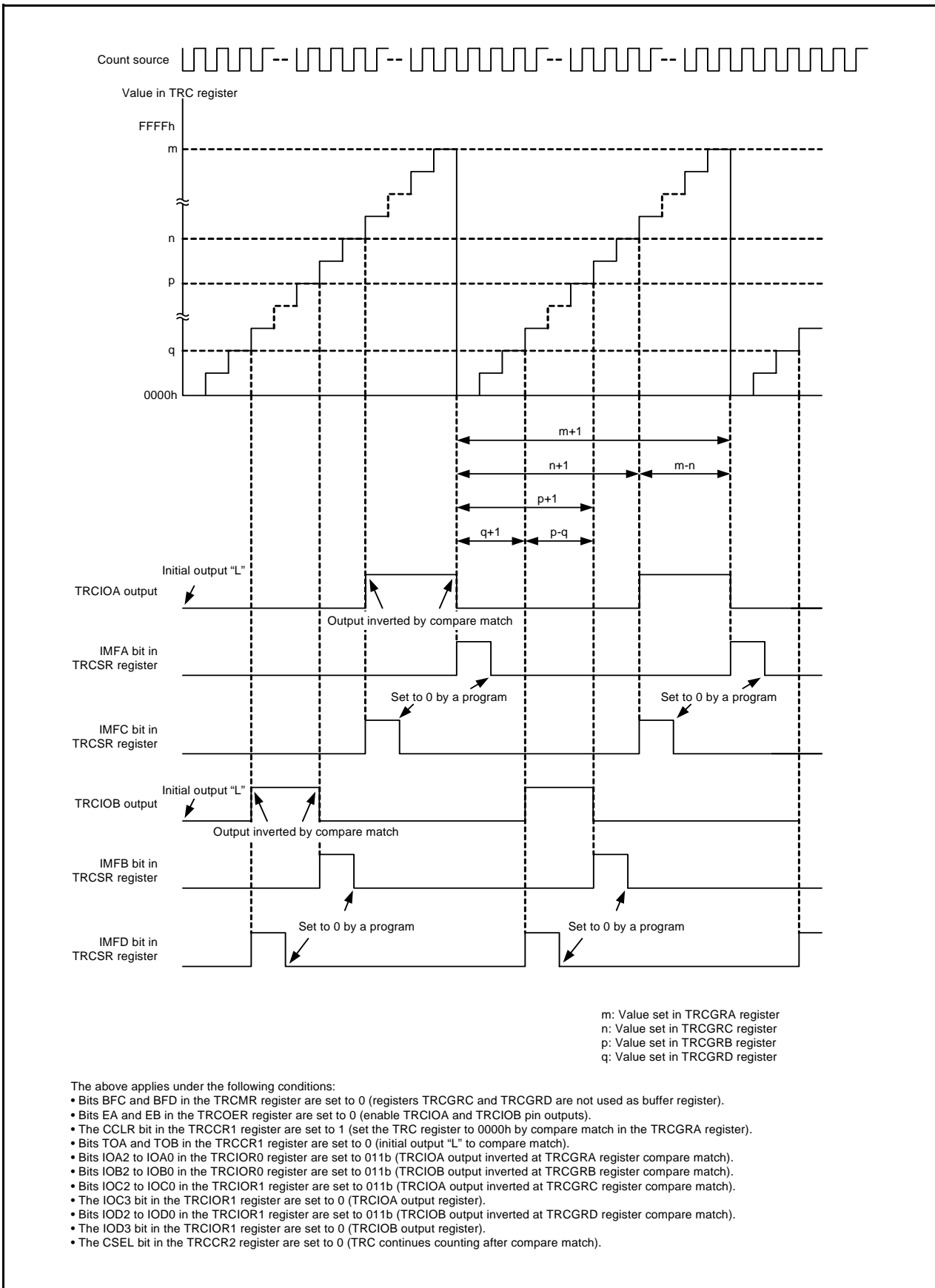
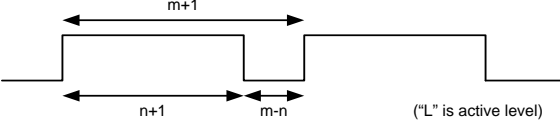

Figure 19.12 Operating Example When TRCGRC Register is Used for Output Control of TRCIOA Pin and TRCGRD Register is Used for Output Control of TRCIOB Pin

19.6 PWM Mode

This mode outputs PWM waveforms. A maximum of three PWM waveforms with the same period are output. The PWM mode, or the timer mode, can be selected for each individual pin. (However, since the TRCGRA register is used when using any pin for the PWM mode, the TRCGRA register cannot be used for the timer mode.) Table 19.11 lists the Specifications of PWM Mode, Figure 19.13 shows a PWM Mode Block Diagram, Table 19.12 lists the Functions of TRCGRh Register in PWM Mode, and Figures 19.14 and 19.15 show Operating Examples of PWM Mode.

Table 19.11 Specifications of PWM Mode

Item	Specification
Count source	f1, f2, f4, f8, f32, fOCO40M, fOCO-F External signal (rising edge) input to TRCCLK pin
Count operation	Increment
PWM waveform	PWM period: $1/f_k \times (m + 1)$ Active level width: $1/f_k \times (m - n)$ Inactive width: $1/f_k \times (n + 1)$ f_k : Count source frequency m : TRCGRA register setting value n : TRCGRj register setting value 
Count start condition	1 (count starts) is written to the TSTART bit in the TRCMR register.
Count stop condition	<ul style="list-style-type: none"> When the CSEL bit in the TRCCR2 register is set to 0 (count continues after compare match with TRCGRA). 0 (count stops) is written to the TSTART bit in the TRCMR register. PWM output pin retains output level before count stops, TRC register retains value before count stops. When the CSEL bit in the TRCCR2 register is set to 1 (count stops at compare match with TRCGRA register). The count stops at the compare match with the TRCGRA register. The PWM output pin retains the level after the output is changed by the compare match.
Interrupt request generation timing	<ul style="list-style-type: none"> Compare match (contents of registers TRC and TRCGRh match) The TRC register overflows.
TRCIOA pin function	Programmable I/O port
TRCIOB, TRCIOC, and TRCIOD pin functions	Programmable I/O port or PWM output (selectable individually for each pin)
INT0 pin function	Programmable I/O port, pulse output forced cutoff signal input, or INT0 interrupt input
Read from timer	The count value can be read by reading the TRC register.
Write to timer	The TRC register can be written to.
Selectable functions	<ul style="list-style-type: none"> One to three pins selectable as PWM output pins One or more of pins TRCIOB, TRCIOC, and TRCIOD Active level selectable for each pin Initial level selectable for each pin Buffer operation (Refer to 19.3.2 Buffer Operation.) Pulse output forced cutoff signal input (Refer to 19.3.4 Forced Cutoff of Pulse Output.) A/D trigger generation

j = B, C, or D

h = A, B, C, or D

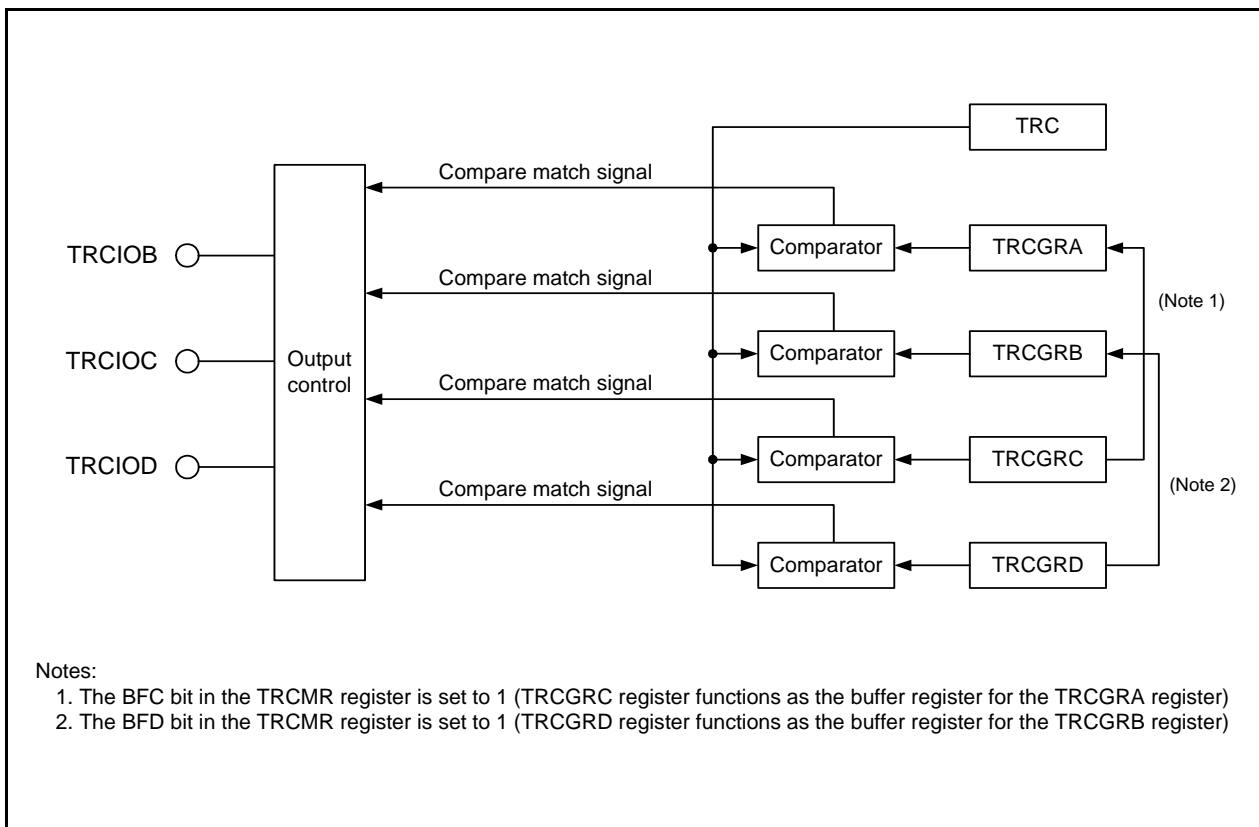

Figure 19.13 PWM Mode Block Diagram

19.6.1 Timer RC Control Register 1 (TRCCR1) in PWM Mode

Address 0121h

Bit	b7	b6	b5	b4	b3	b2	b1	b0
Symbol	CCLR	TCK2	TCK1	TCK0	TOD	TOC	TOB	TOA
After Reset	0	0	0	0	0	0	0	0

Bit	Symbol	Bit Name	Function	R/W
b0	TOA	TRCIOA output level select bit (1)	Disabled in PWM mode	R/W
b1	TOB	TRCIOB output level select bit (1, 2)	0: Initial output selected as non-active level 1: Initial output selected as active level	R/W
b2	TOC	TRCIOC output level select bit (1, 2)		R/W
b3	TOD	TRCIOD output level select bit (1, 2)		R/W
b4	TCK0	Count source select bit (1)	b6 b5 b4 0 0 0: f1 0 0 1: f2 0 1 0: f4 0 1 1: f8 1 0 0: f32 1 0 1: TRCCLK input rising edge 1 1 0: fOCO40M 1 1 1: fOCO-F (3)	R/W
b5	TCK1			R/W
b6	TCK2			R/W
b7	CCLR	TRC counter clear select bit	0: Disable clear (free-running operation) 1: Clear by compare match in the TRCGRA register	R/W

Notes:

1. Set to these bits when the TSTART bit in the TRCMR register is set to 0 (count stops).
2. If the pin function is set for waveform output (refer to **7.5 Port Settings**), the initial output level is output when the TRCCR1 register is set.
3. To select fOCO-F, set it to the clock frequency higher than the CPU clock frequency.

19.6.2 Timer RC Control Register 2 (TRCCR2) in PWM Mode

Address 0130h

Bit	b7	b6	b5	b4	b3	b2	b1	b0
Symbol	TCEG1	TCEG0	CSEL	—	—	POLD	POLC	POLB
After Reset	0	0	0	1	1	0	0	0

Bit	Symbol	Bit Name	Function	R/W
b0	POLB	PWM mode output level control bit B (1)	0: TRCIOB output level selected as "L" active 1: TRCIOB output level selected as "H" active	R/W
b1	POLC	PWM mode output level control bit C (1)	0: TRCIOC output level selected as "L" active 1: TRCIOC output level selected as "H" active	R/W
b2	POLD	PWM mode output level control bit D (1)	0: TRCIOD output level selected as "L" active 1: TRCIOD output level selected as "H" active	R/W
b3	—	Nothing is assigned. If necessary, set to 0. When read, the content is 1.		—
b4	—			
b5	CSEL	TRC count operation select bit (2)	0: Count continues at compare match with the TRCGRA register 1: Count stops at compare match with the TRCGRA register	R/W
b6	TCEG0	TRCTRIG input edge select bit (3)	b7 b6 0 0: Disable the trigger input from the TRCTRIG pin 0 1: Rising edge selected 1 0: Falling edge selected 1 1: Both edges selected	R/W
b7	TCEG1			R/W

Notes:

1. Enabled when in PWM mode.
2. Enabled when in output compare function, PWM mode, or PWM2 mode. For notes on PWM2 mode, refer to **19.9.6 TRCMR Register in PWM2 Mode**.
3. Enabled when in PWM2 mode.

Table 19.12 Functions of TRCGRh Register in PWM Mode

Register	Setting	Register Function	PWM Output Pin
TRCGRA	—	General register. Set the PWM period.	—
TRCGRB	—	General register. Set the PWM output change point.	TRCIOB
TRCGRC	BFC = 0	General register. Set the PWM output change point.	TRCIOC
TRCGRD	BFD = 0		TRCIOD
TRCGRC	BFC = 1	Buffer register. Set the next PWM period. (Refer to 19.3.2 Buffer Operation .)	—
TRCGRD	BFD = 1	Buffer register. Set the next PWM output change point. (Refer to 19.3.2 Buffer Operation .)	TRCIOB

h = A, B, C, or D

BFC, BFD: Bits in TRCMR register

Note:

1. The output level does not change even when a compare match occurs if the TRCGRA register value (PWM period) is the same as the TRCGRB, TRCGRC, or TRCGRD register value.

19.6.3 Operating Example

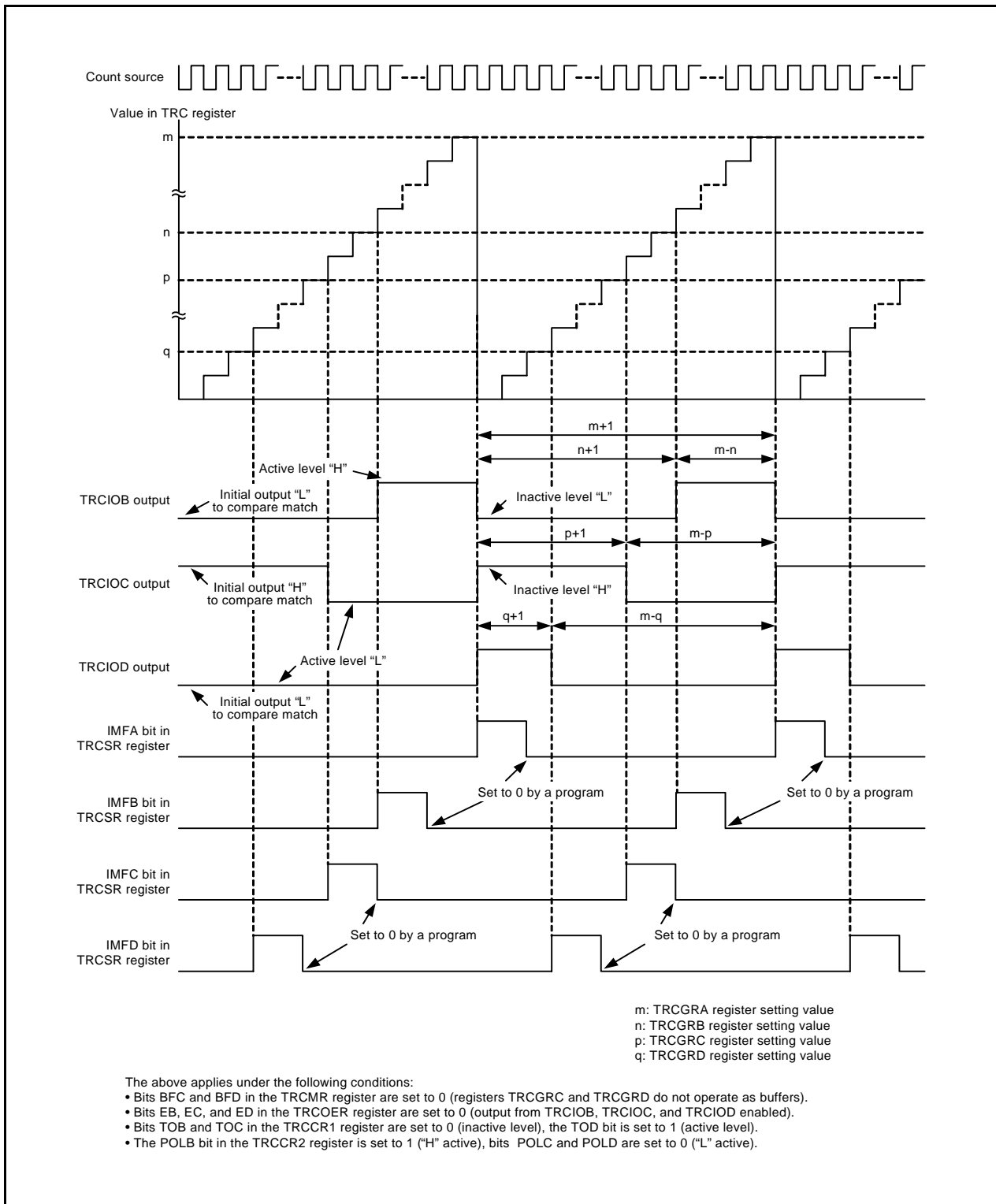

Figure 19.14 Operating Example of PWM Mode

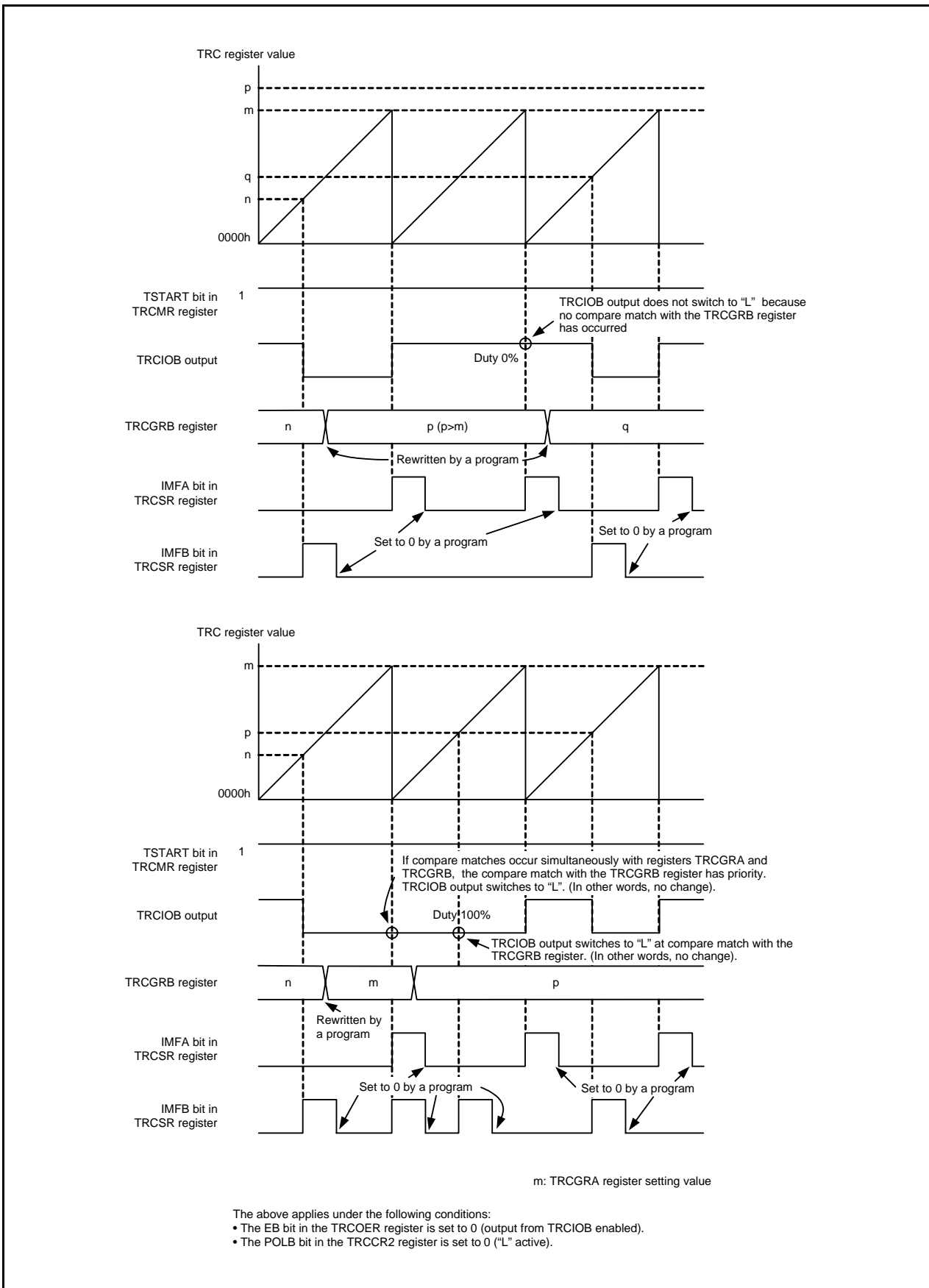

Figure 19.15 Operating Example of PWM Mode (Duty 0% and Duty 100%)

19.7 PWM2 Mode

This mode outputs a single PWM waveform. After a given wait duration has elapsed following the trigger, the pin output switches to active level. Then, after a given duration, the output switches back to inactive level. Furthermore, the counter stops at the same time the output returns to inactive level, making it possible to use PWM2 mode to output a programmable wait one-shot waveform.

Since timer RC uses multiple general registers in PWM2 mode, other modes cannot be used in conjunction with it. Figure 19.16 shows a PWM2 Mode Block Diagram, Table 19.13 lists the Specifications of PWM2 Mode, Table 19.14 lists the Functions of TRCGRj Register in PWM2 Mode, and Figures 19.17 to 19.19 show Operating Examples of PWM2 Mode.

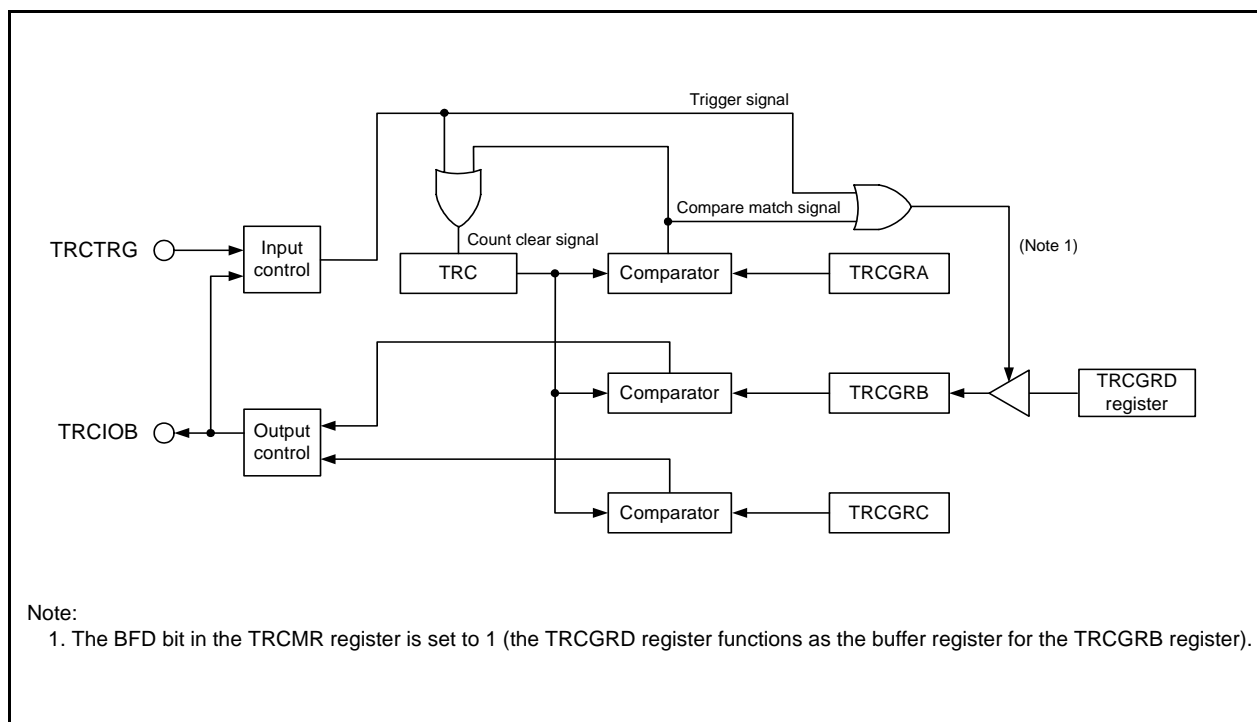

Figure 19.16 PWM2 Mode Block Diagram

Table 19.13 Specifications of PWM2 Mode

Item	Specification
Count source	f1, f2, f4, f8, f32, fOCO40M, fOCO-F External signal (rising edge) input to TRCCLK pin
Count operation	Increment TRC register
PWM waveform	<p>PWM period: $1/fk \times (m + 1)$ (no TRCTRIG input) Active level width: $1/fk \times (n - p)$ Wait time from count start or trigger: $1/fk \times (p + 1)$ fk: Count source frequency m: TRCGRA register setting value n: TRCGRB register setting value p: TRCGRC register setting value</p> <p>(TRCTRIG: Rising edge, active level is "H")</p>
Count start conditions	<ul style="list-style-type: none"> • Bits TCEG1 to TCEG0 in the TRCCR2 register are set to 00b (TRCTRIG trigger disabled) or the CSEL bit in the TRCCR2 register is set to 0 (count continues). 1 (count starts) is written to the TSTART bit in the TRCMR register. • Bits TCEG1 to TCEG0 in the TRCCR2 register are set to 01b, 10b, or 11b (TRCTRIG trigger enabled) and the TSTART bit in the TRCMR register is set to 1 (count starts). A trigger is input to the TRCTRIG pin
Count stop conditions	<ul style="list-style-type: none"> • 0 (count stops) is written to the TSTART bit in the TRCMR register while the CSEL bit in the TRCCR2 register is set to 0 or 1. The TRCIOB pin outputs the initial level in accordance with the value of the TOB bit in the TRCCR1 register. The TRC register retains the value before count stops. • The count stops due to a compare match with TRCGRA while the CSEL bit in the TRCCR2 register is set to 1 The TRCIOB pin outputs the initial level. The TRC register retains the value before count stops if the CCLR bit in the TRCCR1 register is set to 0. The TRC register is set to 0000h if the CCLR bit in the TRCCR1 register is set to 1.
Interrupt request generation timing	<ul style="list-style-type: none"> • Compare match (contents of TRC and TRCGRj registers match) • The TRC register overflows
TRCIOA/TRCTRIG pin function	Programmable I/O port or TRCTRIG input
TRCIOB pin function	PWM output
TRCIOC and TRCIOD pin functions	Programmable I/O port
INT0 pin function	Programmable I/O port, pulse output forced cutoff signal input, or $\overline{\text{INT0}}$ interrupt input
Read from timer	The count value can be read by reading the TRC register.
Write to timer	The TRC register can be written to.
Selectable functions	<ul style="list-style-type: none"> • External trigger and valid edge selection The edge or edges of the signal input to the TRCTRIG pin can be used as the PWM output trigger: rising edge, falling edge, or both rising and falling edges • Buffer operation (Refer to 19.3.2 Buffer Operation.) • Pulse output forced cutoff signal input (Refer to 19.3.4 Forced Cutoff of Pulse Output.) • Digital filter (Refer to 19.3.3 Digital Filter.) • A/D trigger generation

j = A, B, or C

19.7.1 Timer RC Control Register 1 (TRCCR1) in PWM2 Mode

Address 0121h

Bit	b7	b6	b5	b4	b3	b2	b1	b0
Symbol	CCLR	TCK2	TCK1	TCK0	TOD	TOC	TOB	TOA
After Reset	0	0	0	0	0	0	0	0

Bit	Symbol	Bit Name	Function	R/W
b0	TOA	TRCIOA output level select bit (1)	Disabled in PWM2 mode	R/W
b1	TOB	TRCIOB output level select bit (1, 2)	0: Active level "H" (Initial output "L" "H" output by compare match in the TRCGRC register "L" output by compare match in the TRCGRB register) 1: Active level "L" (Initial output "H" "L" output by compare match in the TRCGRC register "H" output by compare match in the TRCGRB register)	R/W
b2	TOC	TRCIOC output level select bit (1)	Disabled in PWM2 mode	R/W
b3	TOD	TRCIOD output level select bit (1)		R/W
b4	TCK0	Count source select bit (1)	b6 b5 b4 0 0 0: f1 0 0 1: f2 0 1 0: f4 0 1 1: f8 1 0 0: f32 1 0 1: TRCLK input rising edge 1 1 0: fOCO40M 1 1 1: fOCO-F (3)	R/W
b5	TCK1			R/W
b6	TCK2			R/W
b7	CCLR	TRC counter clear select bit	0: Disable clear (free-running operation) 1: Clear by compare match in the TRCGRA register	R/W

Notes:

1. Set to these bits when the TSTART bit in the TRCMR register is set to 0 (count stops).
2. If the pin function is set for waveform output (refer to **7.5 Port Settings**), the initial output level is output when the TRCCR1 register is set.
3. To select fOCO-F, set it to the clock frequency higher than the CPU clock frequency.

19.7.2 Timer RC Control Register 2 (TRCCR2) in PWM2 Mode

Address 0130h

Bit	b7	b6	b5	b4	b3	b2	b1	b0
Symbol	TCEG1	TCEG0	CSEL	—	—	POLD	POLC	POLB
After Reset	0	0	0	1	1	0	0	0

Bit	Symbol	Bit Name	Function	R/W
b0	POLB	PWM mode output level control bit B ⁽¹⁾	0: TRCIOB output level selected as “L” active 1: TRCIOB output level selected as “H” active	R/W
b1	POLC	PWM mode output level control bit C ⁽¹⁾	0: TRCIOC output level selected as “L” active 1: TRCIOC output level selected as “H” active	R/W
b2	POLD	PWM mode output level control bit D ⁽¹⁾	0: TRCIOD output level selected as “L” active 1: TRCIOD output level selected as “H” active	R/W
b3	—	Nothing is assigned. If necessary, set to 0. When read, the content is 1.		—
b4	—			
b5	CSEL	TRC count operation select bit ⁽²⁾	0: Count continues at compare match with the TRCGRA register 1: Count stops at compare match with the TRCGRA register	R/W
b6	TCEG0	TRCTRG input edge select bit ⁽³⁾	^{b7 b6} 0 0: Disable the trigger input from the TRCTRG pin 0 1: Rising edge selected 1 0: Falling edge selected 1 1: Both edges selected	R/W
b7	TCEG1			R/W

Notes:

1. Enabled when in PWM mode.
2. Enabled when in output compare function, PWM mode, or PWM2 mode. For notes on PWM2 mode, refer to **19.9.6 TRCMR Register in PWM2 Mode**.
3. Enabled when in PWM2 mode.

19.7.3 Timer RC Digital Filter Function Select Register (TRCDF) in PWM2 Mode

Address 0131h

Bit	b7	b6	b5	b4	b3	b2	b1	b0
Symbol	DFCK1	DFCK0	—	DFTRG	DFD	DFC	DFB	DFA
After Reset	0	0	0	0	0	0	0	0

Bit	Symbol	Bit Name	Function	R/W
b0	DFA	TRCIOA pin digital filter function select bit ⁽¹⁾	0: Function is not used 1: Function is used	R/W
b1	DFB	TRCIOB pin digital filter function select bit ⁽¹⁾		R/W
b2	DFC	TRCIOC pin digital filter function select bit ⁽¹⁾		R/W
b3	DFD	TRCIOD pin digital filter function select bit ⁽¹⁾		R/W
b4	DFTRG	TRCTRГ pin digital filter function select bit ⁽²⁾		R/W
b5	—	Nothing is assigned. If necessary, set to 0. When read, the content is 0.	—	—
b6	DFCK0	Clock select bits for digital filter function ^(1, 2)	b7 b6 0 0: f32 0 1: f8 1 0: f1 1 1: Count source (clock selected by bits TCK2 to TCK0 in the TRCCR1 register)	R/W
b7	DFCK1			R/W

Notes:

- These bits are enabled for the input capture function.
- These bits are enabled when in PWM2 mode and bits TCEG1 to TCEG0 in the TRCCR2 register are set to 01b, 10b, or 11b (TRCTRГ trigger input enabled).

Table 19.14 Functions of TRCGRj Register in PWM2 Mode

Register	Setting	Register Function	PWM2 Output Pin
TRCGRA	—	General register. Set the PWM period.	TRCIOB pin
TRCGRB	—	General register. Set the PWM output change point.	
TRCGRC ⁽¹⁾	BFC = 0	General register. Set the PWM output change point (wait time after trigger).	
TRCGRD ⁽¹⁾	BFD = 0	(Not used in PWM2 mode)	—
TRCGRD	BFD = 1	Buffer register. Set the next PWM output change point. (Refer to 19.3.2 Buffer Operation .)	TRCIOB pin

j = A, B, C, or D

BFC, BFD: Bits in TRCMR register

Note:

- Do not set the TRCGRB and TRCGRC registers to the same value.

19.7.4 Operating Example

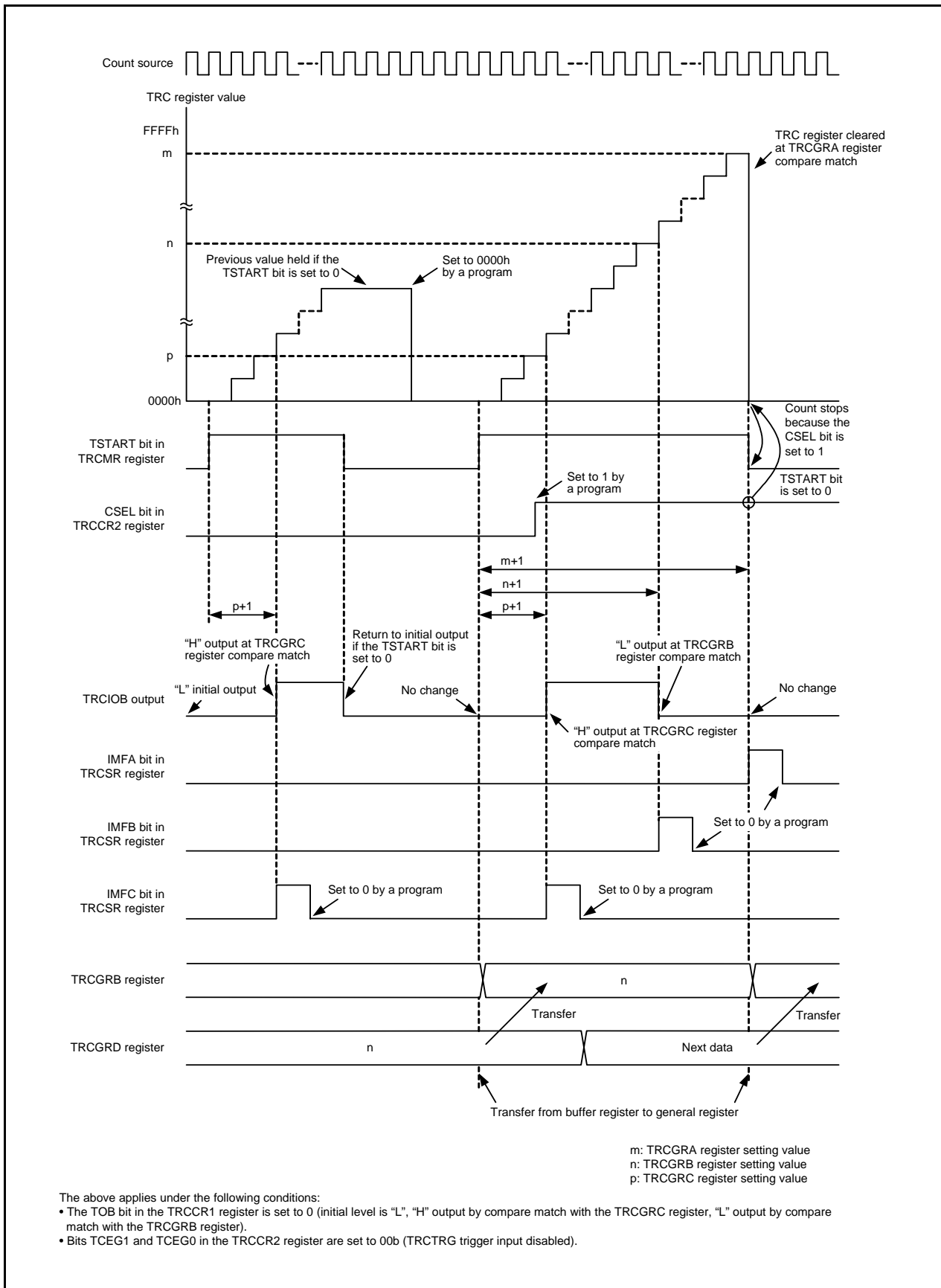

Figure 19.17 Operating Example of PWM2 Mode (TRCTRГ Trigger Input Disabled)

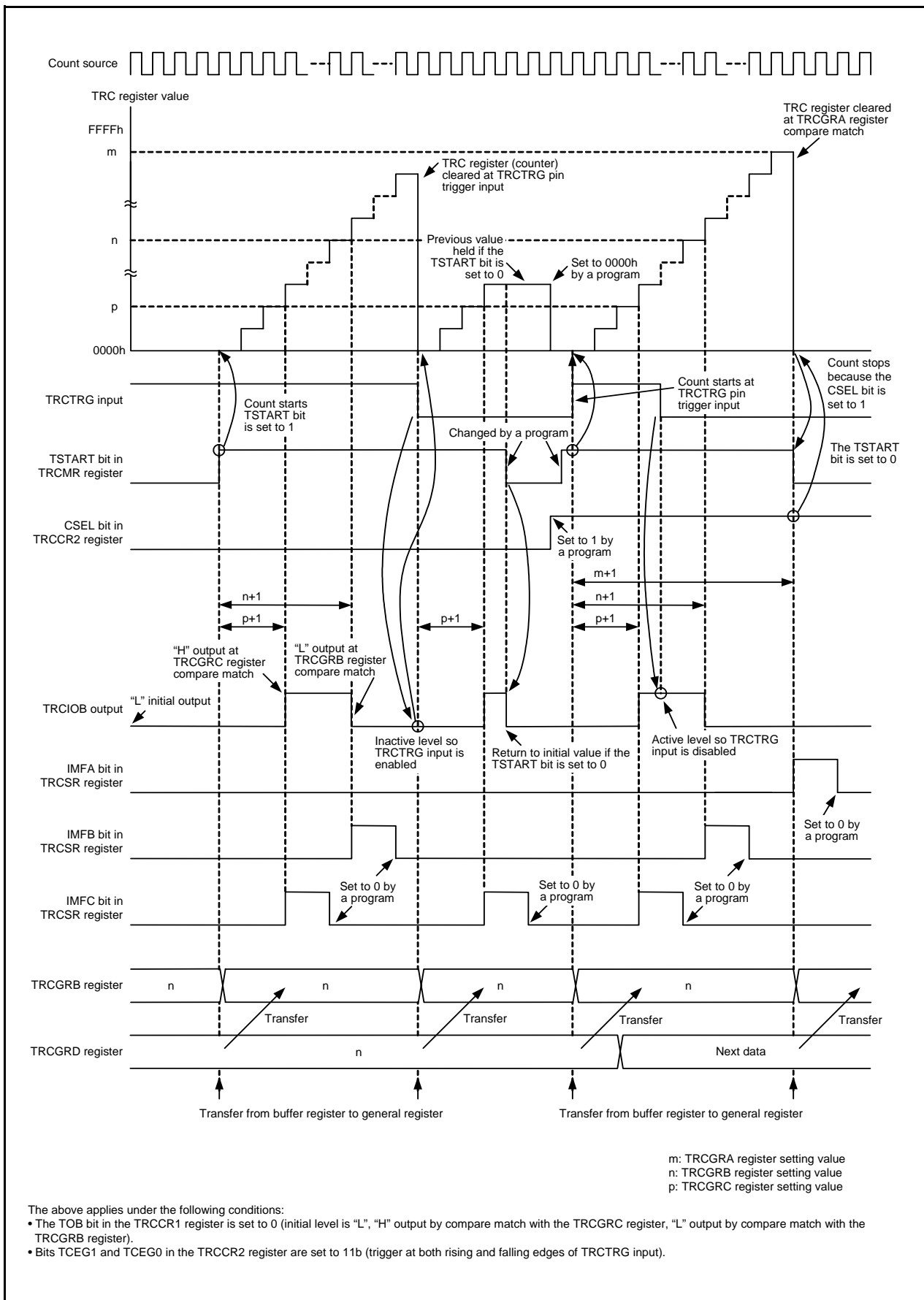

Figure 19.18 Operating Example of PWM2 Mode (TRCTRГ Trigger Input Enabled)

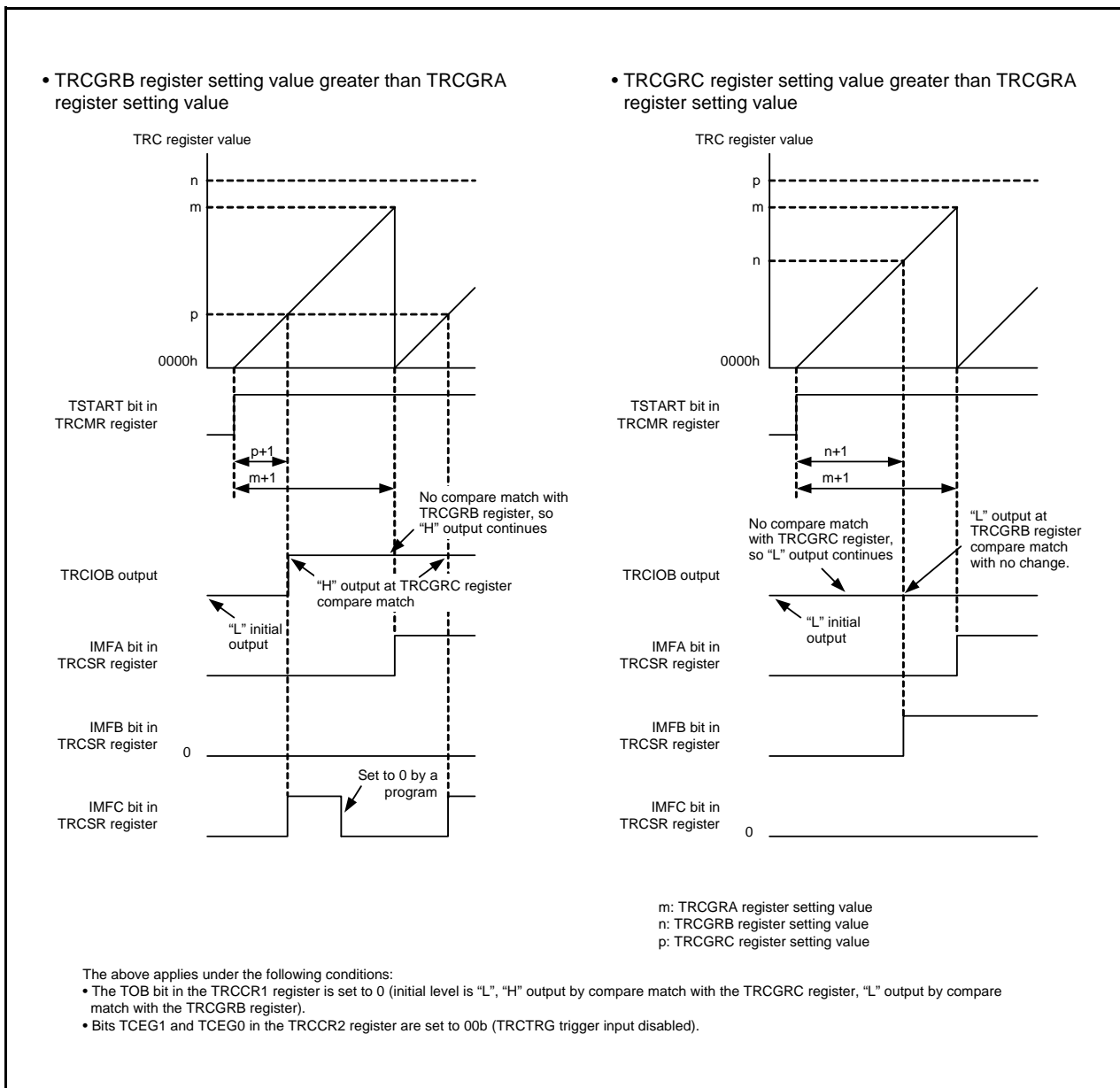

Figure 19.19 Operating Example of PWM2 Mode (Duty 0% and Duty 100%)

19.8 Timer RC Interrupt

Timer RC generates a timer RC interrupt request from five sources. The timer RC interrupt uses the single TRCIC register (bits IR and ILVL0 to ILVL2) and a single vector.

Table 19.15 lists the Registers Associated with Timer RC Interrupt, and Figure 19.20 is a Timer RC Interrupt Block Diagram.

Table 19.15 Registers Associated with Timer RC Interrupt

Timer RC Status Register	Timer RC Interrupt Enable Register	Timer RC Interrupt Control Register
TRCSR	TRCIER	TRCIC

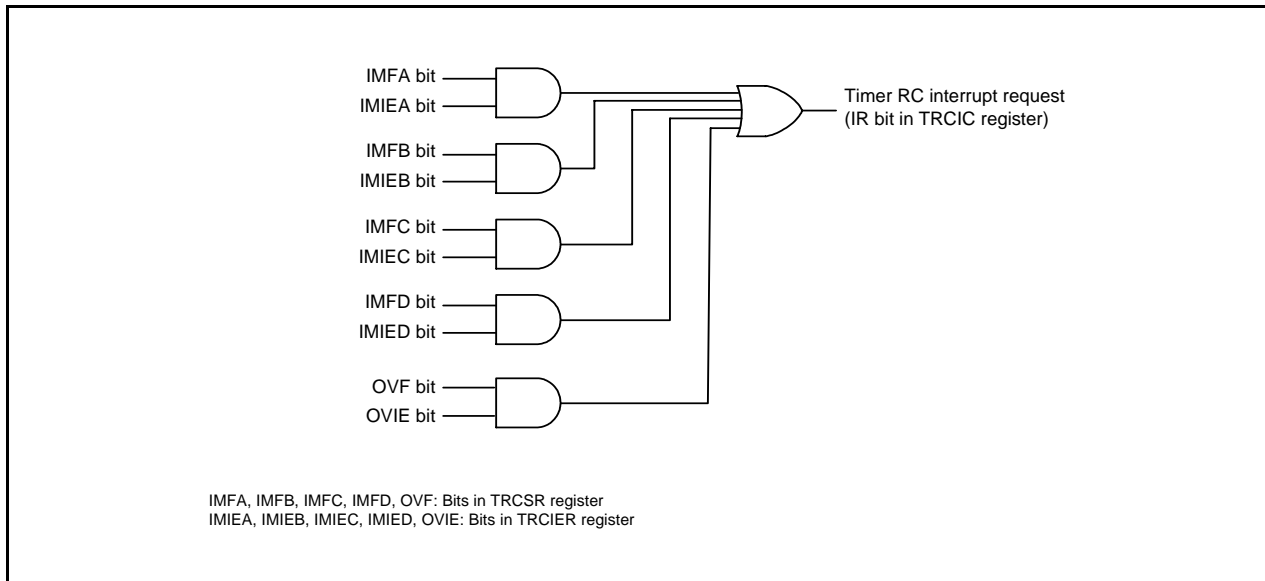

Figure 19.20 Timer RC Interrupt Block Diagram

Like other maskable interrupts, the timer RC interrupt is controlled by the combination of the I flag, IR bit, bits ILVL0 to ILVL2, and IPL. However, it differs from other maskable interrupts in the following respects because a single interrupt source (timer RC interrupt) is generated from multiple interrupt request sources.

- The IR bit in the TRCIC register is set to 1 (interrupt requested) when a bit in the TRCSR register is set to 1 and the corresponding bit in the TRCIER register is also set to 1 (interrupt enabled).
- The IR bit is set to 0 (no interrupt requested) when the bit in the TRCSR register or the corresponding bit in the TRCIER register is set to 0, or both are set to 0. In other words, the interrupt request is not maintained if the IR bit is once set to 1 but the interrupt is not acknowledged.
- If another interrupt source is triggered after the IR bit is set to 1, the IR bit remains set to 1 and does not change.
- If multiple bits in the TRCIER register are set to 1, use the TRCSR register to determine the source of the interrupt request.
- The bits in the TRCSR register are not automatically set to 0 when an interrupt is acknowledged. Set them to 0 within the interrupt routine. Refer to **19.2.5 Timer RC Status Register (TRCSR)**, for the procedure for setting these bits to 0.

Refer to **19.2.4 Timer RC Interrupt Enable Register (TRCIER)**, for details of the TRCIER register.

Refer to **11.3 Interrupt Control**, for details of the TRCIC register and **11.1.5.2 Relocatable Vector Tables**, for information on interrupt vectors.

19.9 Notes on Timer RC

19.9.1 TRC Register

- The following note applies when the CCLR bit in the TRCCR1 register is set to 1 (clear TRC register at compare match with TRCGRA register).

When using a program to write a value to the TRC register while the TSTART bit in the TRCMR register is set to 1 (count starts), ensure that the write does not overlap with the timing with which the TRC register is set to 0000h.

If the timing of the write to the TRC register and the setting of the TRC register to 0000h coincide, the write value will not be written to the TRC register and the TRC register will be set to 0000h.

- Reading from the TRC register immediately after writing to it can result in the value previous to the write being read out. To prevent this, execute the JMP.B instruction between the read and the write instructions.

```

Program Example      MOV.W      #XXXXh, TRC          ;Write
                    JMP.B      L1              ;JMP.B instruction
                    L1:        MOV.W      TRC,DATA      ;Read

```

19.9.2 TRCSR Register

Reading from the TRCSR register immediately after writing to it can result in the value previous to the write being read out. To prevent this, execute the JMP.B instruction between the read and the write instructions.

```

Program Example      MOV.B      #XXh, TRCSR        ;Write
                    JMP.B      L1              ;JMP.B instruction
                    L1:        MOV.B      TRCSR,DATA ;Read

```

19.9.3 TRCCR1 Register

To set bits TCK2 to TCK0 in the TRCCR1 register to 111b (fOCO-F), set fOCO-F to the clock frequency higher than the CPU clock frequency.

19.9.4 Count Source Switching

- Stop the count before switching the count source.

Switching procedure

- Set the TSTART bit in the TRCMR register to 0 (count stops).
- Change the settings of bits TCK2 to TCK0 in the TRCCR1 register.

- When changing the count source from fOCO40M to another clock other than fOCO-F and stopping fOCO40M, wait 2 cycles of f1 or more after setting the clock switch, and then stop fOCO40M.

Switching procedure

- Set the TSTART bit in the TRCMR register to 0 (count stops).
- Change the settings of bits TCK2 to TCK0 in the TRCCR1 register.
- Wait for a minimum of two cycles of f1.
- Set the FRA00 bit in the FRA0 register to 0 (high-speed on-chip oscillator off).

- After switching the count source from fOCO-F to a clock other than fOCO40M, allow a minimum of one cycle of fOCO-F + fOCO40M to elapse after changing the clock setting before stopping fOCO-F.

Switching procedure

- (1) Set the TSTART bit in the TRCMR register to 0 (count stops).
- (2) Change the settings of bits TCK2 to TCK0 in the TRCCR1 register.
- (3) Wait for a minimum of one cycle of fOCO-F + fOCO40M.
- (4) Set the FRA00 bit in the FRA0 register to 0 (high-speed on-chip oscillator off).

19.9.5 Input Capture Function

- Set the pulse width of the input capture signal as follows:
 - [When the digital filter is not used]
Three or more cycles of the timer RC operation clock (refer to **Table 19.1 Timer RC Operation Clock**)
 - [When the digital filter is used]
Five cycles of the digital filter sampling clock + three cycles of the timer RC operating clock, minimum (refer to **Figure 19.5 Digital Filter Block Diagram**)
- The value of the TRC register is transferred to the TRCGRj register one or two cycles of the timer RC operation clock after the input capture signal is input to the TRCIOj (j = A, B, C, or D) pin (when the digital filter function is not used).
- When the input capture function is used, if an edge selected by bits IOj0 and IOj1 (j = A, B, C, or D) in the TRCIOR0 or TRCIOR1 register is input to the TRCIOj pin, the IMFj bit in the TRCSR register is set to 1 even when the TSTART bit in the TRCMR register is 0 (count stops).

19.9.6 TRCMR Register in PWM2 Mode

When the CSEL bit in the TRCCR2 register is set to 1 (count stops at compare match with the TRCGRA register), do not set the TRCMR register at compare match timing of registers TRC and TRCGRA.

20. Timer RD

Note

Timer RD in these products does not support full-spec emulators. Use the on-chip debugging emulator for debugging.

Timer RD has 2 16-bit timers (timer RD0 and timer RD1).

20.1 Overview

Timer RD_i (i=0 or 1) has 4 I/O pins.

The operation clock of timer RD is f1, fOCO40M or fOCO-F. Table 20.1 lists the Timer RD Operation Clocks.

Table 20.1 Timer RD Operation Clocks

Condition	Operation Clock of Timer RD
The count source is f1, f2, f4, f8, f32, or TRDCLK input (bits TCK2 to TCK0 in registers TRDCR0 and TRDCR1 are set to a value from 000b to 101b).	f1
The count source is fOCO40M (bits TCK2 to TCK0 in registers TRDCR0 and TRDCR1 are set to 110b).	fOCO40M
The count source is fOCO-F (bits TCK2 to TCK0 in registers TRDCR0 and TRDCR1 are set to 111b).	fOCO-F

Figure 20.1 shows a Timer RD Block Diagram, and Table 20.2 lists Pin Configuration of Timer RD.

Timer RD has 5 modes:

- Timer mode
 - Input capture function Transfer the counter value to a register with an external signal as the trigger
 - Output compare function Detect register value matches with a counter (Pin output can be changed at detection)

The following 4 modes use the output compare function.

- PWM mode Output pulse of any width continuously
- Reset synchronous PWM mode Output three-phase waveforms (6) without sawtooth wave modulation and dead time
- Complementary PWM mode Output three-phase waveforms (6) with triangular wave modulation and dead time
- PWM3 mode Output PWM waveforms (2) with a fixed period

In the input capture function, output compare function, and PWM mode, timer RD0 and timer RD1 have the equivalent functions, and functions or modes can be selected individually for each pin. Also, a combination of these functions and modes can be used in timer RD_i.

In reset synchronous PWM mode, complementary PWM mode, and PWM3 mode, a waveform is output with a combination of counters and registers in timer RD0 and timer RD1.

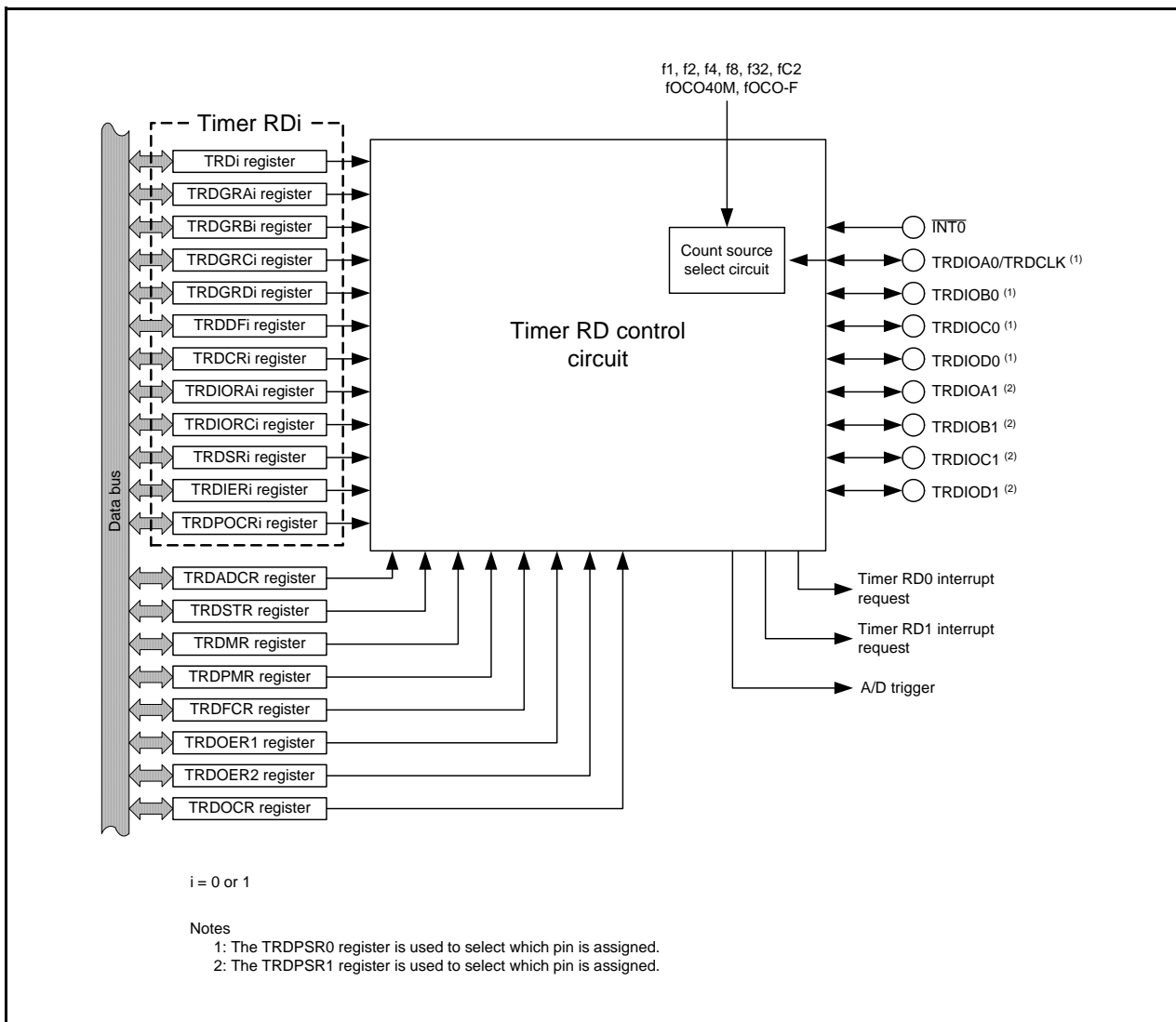

Figure 20.1 Timer RD Block Diagram

Table 20.2 Pin Configuration of Timer RD

Pin Name	Assigned Pin	I/O	Function
TRDIOA0/TRDCLK	P3_5	I/O	Function varies according to the mode. Refer to descriptions of individual modes for details.
TRDIOB0	P3_4	I/O	
TRDIOC0	P3_7	I/O	
TRDIOD0	P3_3	I/O	
TRDIOA1	P3_0	I/O	
TRDIOB1	P1_1	I/O	
TRDIOC1	P1_2	I/O	
TRDIOD1	P1_3	I/O	

20.2 Common Items for Multiple Modes

20.2.1 Count Sources

The count source selection method is the same in all modes. The external clock cannot be selected in PWM3 mode.

Table 20.3 Count Source Selection

Count Source	Selection
f1, f2, f4, f8, f32	The count source is selected by bits TCK2 to TCK0 in the TRDCR _i register.
fOCO40M ⁽¹⁾ fOCO-F	The FRA00 bit in the FRA0 register is set to 1 (high-speed on-chip oscillator frequency). Bits TCK2 to TCK0 in the TRDCR _i register is set to 110b (fOCO40M). Bits TCK2 to TCK0 in the TRDCR _i register is set to 111b (fOCO-F).
External signal input to TRDCLK pin	The STCLK bit in the TRDFCR register is set to 1 (external clock input enabled). Bits TCK2 to TCK0 in the TRDCR _i register are set to 101b (count source: external clock). The valid edge is selected by bits CKEG1 to CKEG0 in the TRDCR _i register. The PD3_5 bit in the PD3 register is set to 0 (input mode).

i = 0 or 1

Note:

- The count source fOCO40M can be used with VCC = 2.7 to 5.5 V.

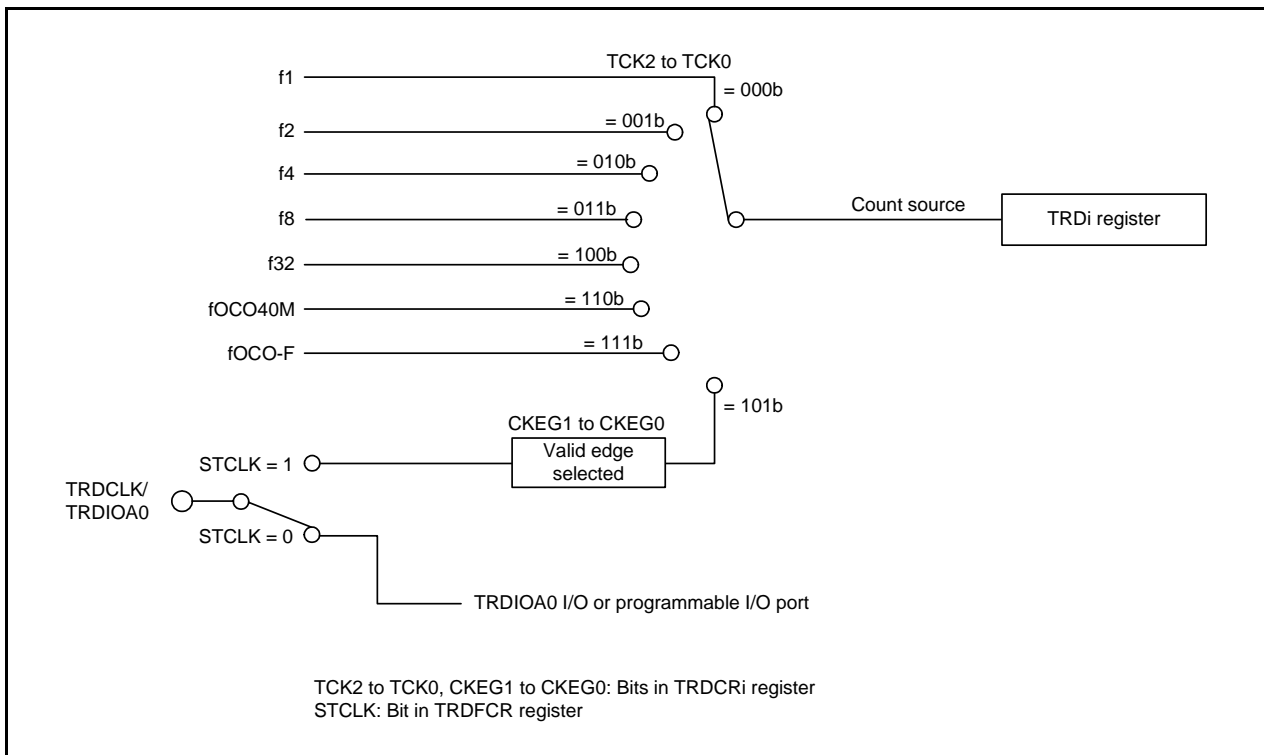

Figure 20.2 Block Diagram of Count Source

Set the pulse width of the external clock which inputs to the TRDCLK pin to 3 cycles or above of the operation clock of timer RD (refer to **Table 20.1 Timer RD Operation Clocks**).

When selecting fOCO40M or fOCO-F for the count source, set the FRA00 bit in the FRA0 register to 1 (high-speed on-chip oscillator on) before setting bits TCK2 to TCK0 in the TRDCR_i (i = 0 or 1) register to 110b (fOCO40M) or 111b (fOCO-F).

20.2.2 Buffer Operation

The TRDGRC_i ($i = 0$ or 1) register can be used as the buffer register of the TRDGRA_i register, and the TRDGRD_i register can be used as the buffer register of the TRDGRB_i register by means of bits BFC_i and BFD_i in the TRDMR register.

- TRDGRA_i buffer register: TRDGRC_i register
- TRDGRB_i buffer register: TRDGRD_i register

Buffer operation depends on the mode. Table 20.4 lists the Buffer Operation in Each Mode.

Table 20.4 Buffer Operation in Each Mode

Function and Mode	Transfer Timing	Transfer Register
Input capture function	Input capture signal input	Transfer content in TRDGRA _i (TRDGRB _i) register to buffer register
Output compare function	Compare match with TRD _i register and TRDGRA _i (TRDGRB _i) register	Transfer content in buffer register to TRDGRA _i (TRDGRB _i) register
PWM mode		
Reset synchronous PWM mode	Compare match with TRD ₀ register and TRDGRA ₀ register	Transfer content in buffer register to TRDGRA _i (TRDGRB _i) register
Complementary PWM mode	<ul style="list-style-type: none"> • Compare match with TRD₀ register and TRDGRA₀ register • TRD₁ register underflow 	Transfer content in buffer register to registers TRDGRB ₀ , TRDGRA ₁ , and TRDGRB ₁
PWM3 mode	Compare match with TRD ₀ register and TRDGRA ₀ register	Transfer content in buffer register to registers TRDGRA ₀ , TRDGRB ₀ , TRDGRA ₁ , and TRDGRB ₁

$i = 0$ or 1

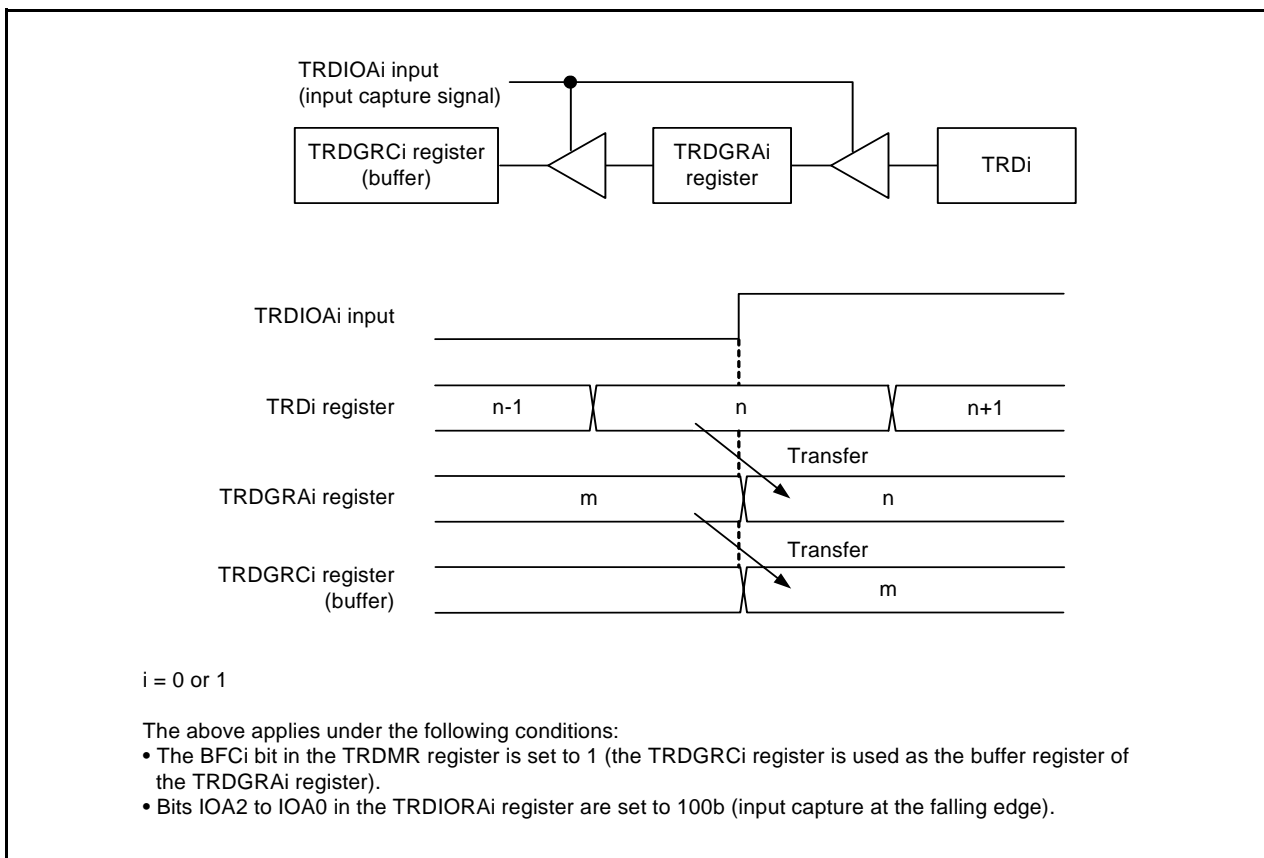

Figure 20.3 Buffer Operation in Input Capture Function

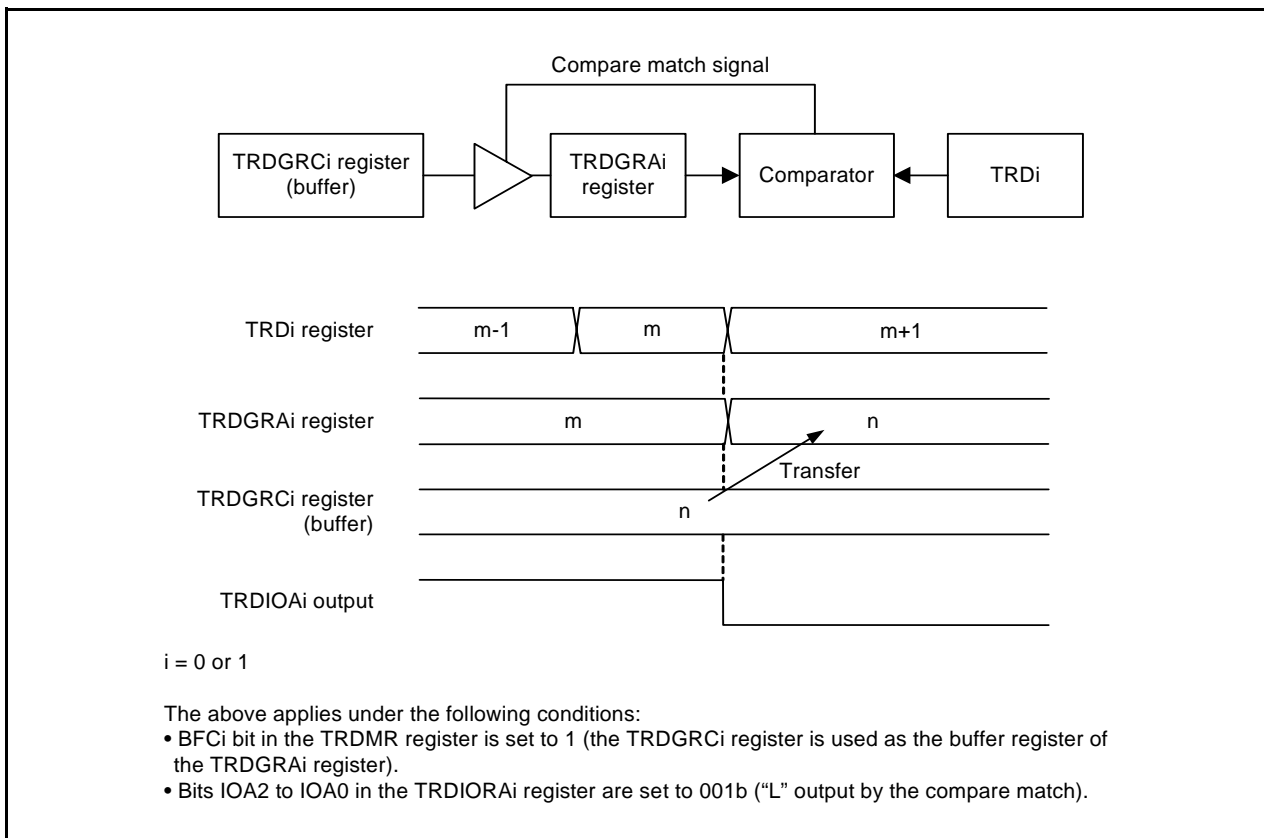

Figure 20.4 Buffer Operation in Output Compare Function

Perform the following for the timer mode (input capture and output compare functions).

When using the TRDGRCi ($i = 0 \text{ or } 1$) register as the buffer register of the TRDGRAi register

- Set the IOC3 bit in the TRDIORCi register to 1 (general register or buffer register).
- Set the IOC2 bit in the TRDIORCi register to the same value as the IOA2 bit in the TRDIORAi register.

When using the TRDGRDi register as the buffer register of the TRDGRBi register

- Set the IOD3 bit in the TRDIORCi register to 1 (general register or buffer register).
- Set the IOD2 bit in the TRDIORCi register to the same value as the IOB2 bit in the TRDIORAi register.

Bits IMFC and IMFD in the TRDSRi register are set to 1 at the input edge of the TRDIOCi pin when also using registers TRDGRCi and TRDGRDi as the buffer register in the input capture function.

When also using registers TRDGRCi and TRDGRDi as buffer registers for the output compare function, reset synchronous PWM mode, complementary PWM mode, and PWM3 mode, bits IMFC and IMFD in the TRDSRi register are set to 1 by a compare match with the TRDi register.

20.2.3 Synchronous Operation

The TRD1 register is synchronized with the TRD0 register.

- Synchronous preset

When the SYNC bit in the TRDMR register is set to 1 (synchronous operation), the data is written to both the TRD0 and TRD1 registers after writing to the TRDi register.

- Synchronous clear

When the SYNC bit in the TRDMR register is set to 1 and bits CCLR2 to CCLR0 in the TRDCRi register are set to 011b (synchronous clear), the TRD0 register is set to 0000h at the same time as the TRD1 register is set to 0000h.

Also, when the SYNC bit in the TRDMR register is set to 1 and bits CCLR2 to CCLR0 in the TRDCRi register are set to 011b (synchronous clear), the TRD1 register is set to 0000h at the same time as the TRD0 register is set to 0000h.

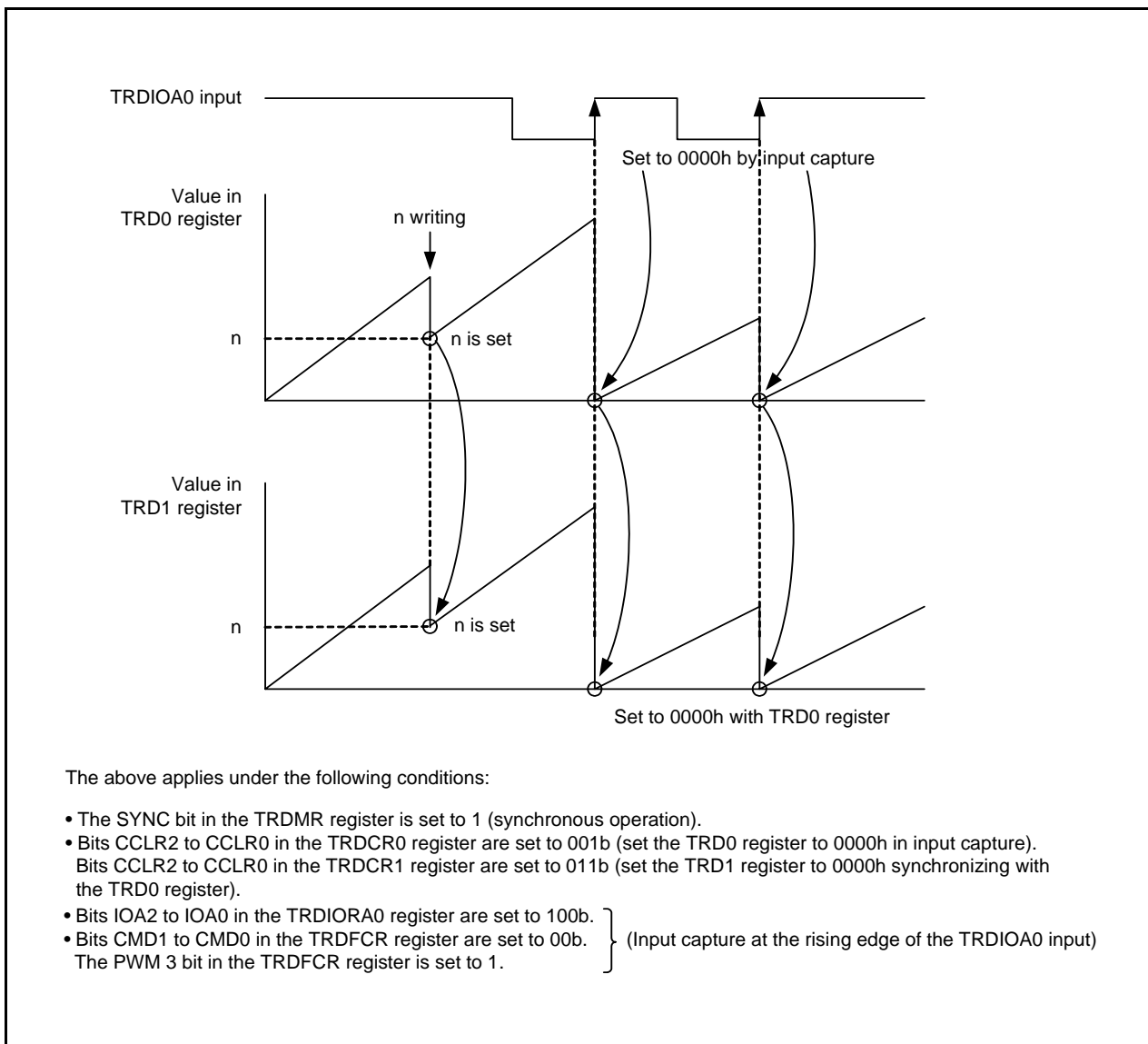

Figure 20.5 Synchronous Operation

20.2.4 Pulse Output Forced Cutoff

In the output compare function, PWM mode, reset synchronous PWM mode, complementary PWM mode, and PWM3 mode, the TRDIO_{ji} (i = 0 or 1, j = A, B, C, or D) output pin can be forcibly set to a programmable I/O port by the $\overline{\text{INT0}}$ pin input, and pulse output can be cut off.

The pins used for output in these functions or modes can function as the output pin of timer RD when the applicable bit in the TRDOER1 register is set to 0 (enable timer RD output). When the PTO bit in the TRDOER2 register is set to 1 (pulse output forced cutoff signal input $\overline{\text{INT0}}$ enabled), all bits in the TRDOER1 register are set to 1 (disable timer RD output, the TRDIO_{ji} output pin is used as the programmable I/O port) after “L” is applied to the $\overline{\text{INT0}}$ pin. The TRDIO_{ji} output pin is set to the programmable I/O port after “L” is applied to the $\overline{\text{INT0}}$ pin and waiting for 1 to 2 cycles of the timer RD operation clock (refer to **Table 20.1 Timer RD Operation Clocks**).

Make the following settings to use this function:

- Set the pin status (high impedance, “L” or “H” output) to pulse output forced cutoff by registers P1, P3 and PD1, PD3.
- Set the INT0EN bit in the INTEN register to 1 ($\overline{\text{INT0}}$ input enabled) and the INT0PL bit to 0 (one edge), and set the POL bit in the INTOIC register to 0 (falling edge selected).
- Set the PD4_5 bit in the PD4 register to 0 (input mode).
- Set the $\overline{\text{INT0}}$ digital filter by bits INT0F1 to INT0F0 in the INTF register.
- Set the PTO bit in the TRDOER2 register to 1 (pulse output forced cutoff signal input $\overline{\text{INT0}}$ enabled).

The IR bit in the INTOIC register is set to 1 (interrupt requested) in accordance with the setting of the POL bit in the INTOIC register and the INT0PL bit in the INTEN register and a change in the $\overline{\text{INT0}}$ pin input (refer to **11.8 Notes on Interrupts**).

For details on interrupts, refer to **11. Interrupts**.

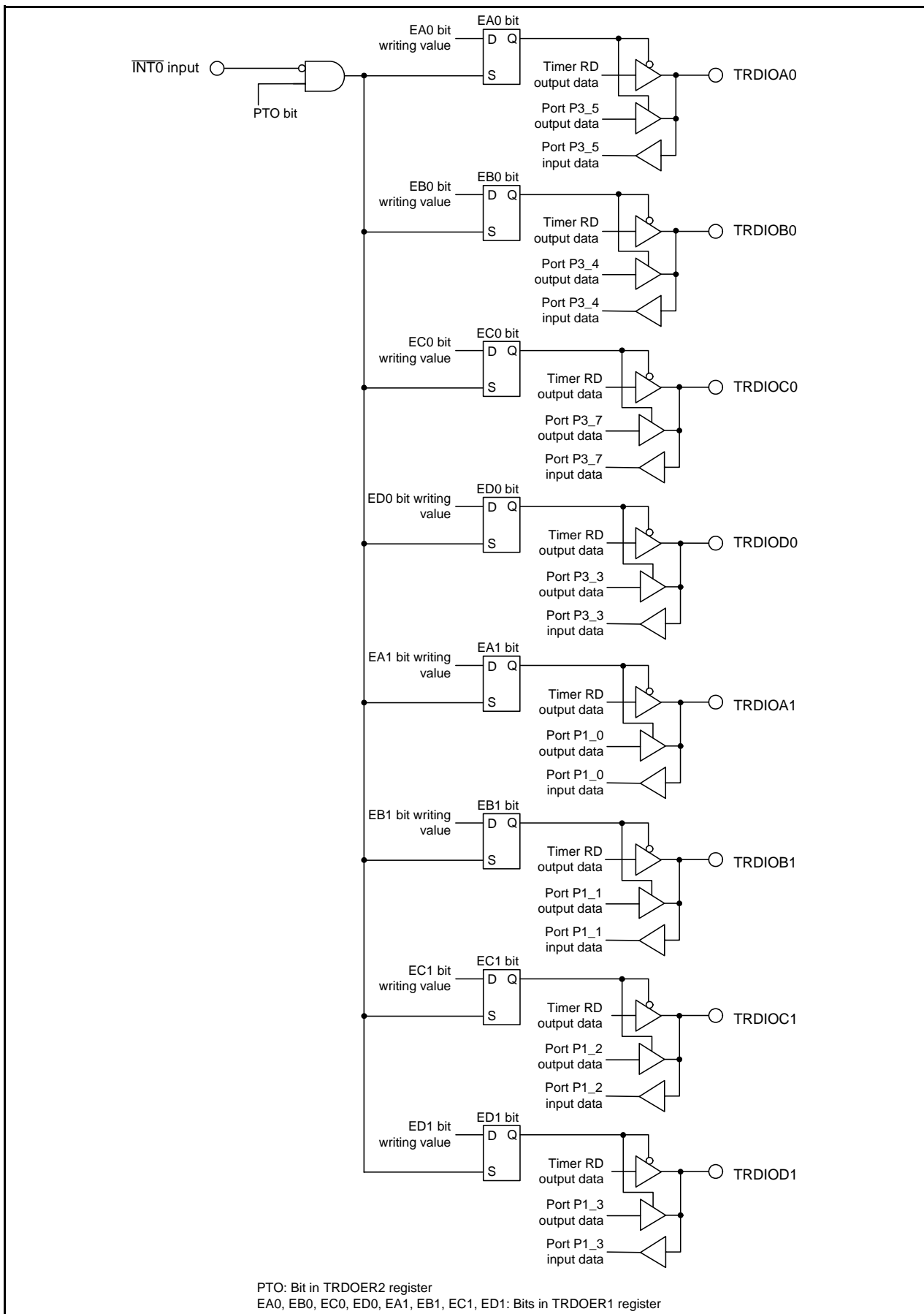

Figure 20.6 Pulse Output Forced Cutoff

20.3 Timer Mode (Input Capture Function)

The input capture function measures the external signal width and period. The content of the TRD_i register (counter) is transferred to the TRDGR_{ji} register as a trigger of the TRDIO_{ji} ($i = 0$ or 1 , $j = A, B, C$, or D) pin external signal (input capture). Since this function is enabled with a combination of the TRDIO_{ji} pin and TRDGR_{ji} register, the input capture function, or any other mode or function, can be selected for each individual pin.

The TRDGRA0 register can also select fOCO128 signal as input-capture trigger input.

Figure 20.7 shows a Block Diagram of Input Capture Function, Table 20.5 lists the Input Capture Function Specifications. Figure 20.8 shows an Operating Example of Input Capture Function.

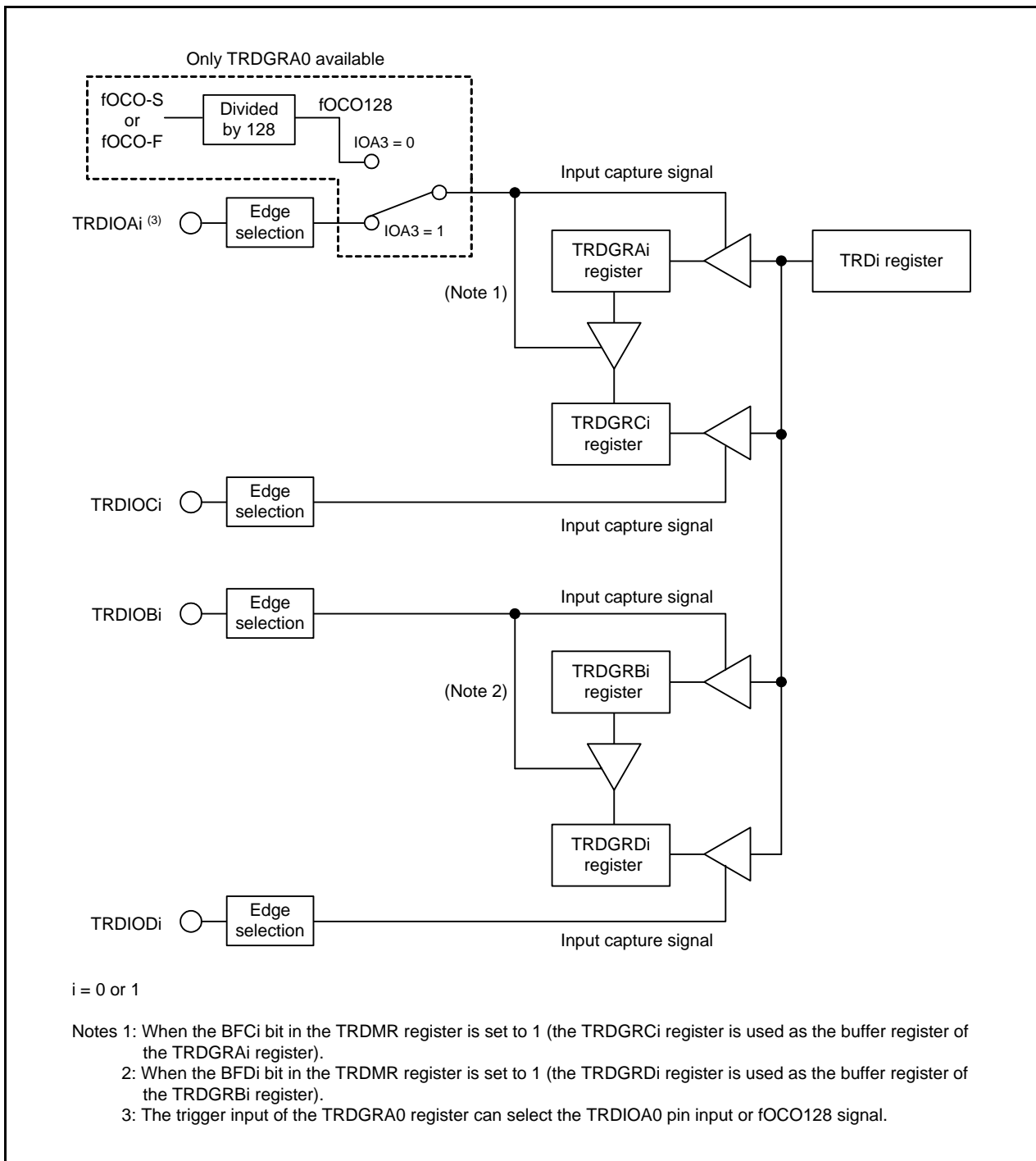

Figure 20.7 Block Diagram of Input Capture Function

Table 20.5 Input Capture Function Specifications

Item	Specification
Count sources	f1, f2, f4, f8, f32, fOCO40M, fOCO-F External signal input to the TRDCLK pin (valid edge selected by a program)
Count operations	Increment
Count period	When bits CCLR2 to CCLR0 in the TRDCRi register are set to 000b (free-running operation). $1/fk \times 65536$ fk: Frequency of count source
Count start condition	1 (count starts) is written to the TSTARTi bit in the TRDSTR register.
Count stop condition	0 (count stops) is written to the TSTARTi bit in the TRDSTR register when the CSELi bit in the TRDSTR register is set to 1.
Interrupt request generation timing	<ul style="list-style-type: none"> Input capture (valid edge of TRDIOji input or fOCO128 signal edge) TRDi register overflows
TRDIOA0 pin function	Programmable I/O port, input-capture input, or TRDCLK (external clock) input
TRDIOB0, TRDIOC0, TRDIOD0, TRDIOA1 to TRDIOD1 pin functions	Programmable I/O port, or input-capture input (selectable by pin)
INT0 pin function	Programmable I/O port or INT0 interrupt input
Read from timer	The count value can be read by reading the TRDi register.
Write to timer	<ul style="list-style-type: none"> When the SYNC bit in the TRDMR register is set to 0 (timer RD0 and timer RD1 operate independently). Data can be written to the TRDi register. When the SYNC bit in the TRDMR register is set to 1 (timer RD0 and timer RD1 operate synchronously). Data can be written to both the TRD0 and TRD1 registers by writing to the TRDi register.
Selectable functions	<ul style="list-style-type: none"> Input-capture input pin selection Either 1 pin or multiple pins among TRDIOAi, TRDIOBi, TRDIOCi, or TRDIODi. Input-capture input valid edge selection The rising edge, falling edge, or both the rising and falling edges Timing for setting the TRDi register to 0000h At overflow or input capture Buffer operation (Refer to 20.2.2 Buffer Operation.) Synchronous operation (Refer to 20.2.3 Synchronous Operation.) Digital filter The TRDIOji input is sampled, and when the sampled input level match as 3 times, the level is determined. Input-capture trigger selection fOCO128 can be selected for input-capture trigger input of the TRDGRA0 register.

i = 0 or 1, j = A, B, C, or D

20.3.1 Module Standby Control Register (MSTCR)

Address 0008h

Bit	b7	b6	b5	b4	b3	b2	b1	b0
Symbol	—	—	MSTTRC	MSTTRD	MSTIIC	—	—	—
After Reset	0	0	0	0	0	0	0	0

Bit	Symbol	Bit Name	Function	R/W
b0	—	Nothing is assigned. If necessary, set to 0. When read, the content is 0.		—
b1	—			
b2	—			
b3	MSTIIC	SSU standby bit	0: Active 1: Standby ⁽¹⁾	R/W
b4	MSTTRD	Timer RD standby bit	0: Active 1: Standby ^(2, 3)	R/W
b5	MSTTRC	Timer RC standby bit	0: Active 1: Standby ⁽⁴⁾	R/W
b6	—	Reserved bit	Set to 0.	R/W
b7	—	Nothing is assigned. If necessary, set to 0. When read, the content is 0.		—

Notes:

1. Stop the SSU and the I²C bus functions before setting to standby. When the MSTIIC bit is set to 1 (standby), any access to the SSU associated registers (addresses 0193h to 019Dh) is disabled.
2. Stop the timer RD function before setting to standby. When the MSTTRD bit is set to 1 (standby), any access to the timer RD associated registers (addresses 0135h to 015Fh) is disabled.
3. To set the MSTTRD bit to 1 (standby), set bits TCK2 to TCK0 in the TRDCR_i (i = 0 or 1) register to 000b (f1).
4. Stop the timer RC function before setting to standby. When the MSTTRC bit is set to 1 (standby), any access to the timer RC associated registers (addresses 0120h to 0133h) is disabled.

20.3.2 Timer RD Start Register (TRDSTR) [Timer Mode (in Input Capture Function)]

Address 0137h

Bit	b7	b6	b5	b4	b3	b2	b1	b0
Symbol	—	—	—	—	CSEL1	CSEL0	TSTART1	TSTART0
After Reset	1	1	1	1	1	1	0	0

Bit	Symbol	Bit Name	Function	R/W
b0	TSTART0	TRD0 count start flag	0: Count stops	R/W
b1	TSTART1	TRD1 count start flag	1: Count starts	R/W
b2	CSEL0	TRD0 count operation select bit	Set to 1 in the input capture function.	R/W
b3	CSEL1	TRD1 count operation select bit		R/W
b4	—	Nothing is assigned. If necessary, set to 0. When read, the content is 1.		—
b5	—			
b6	—			
b7	—			

Set the TRDSTR register using the MOV instruction (do not use the bit handling instruction). Refer to **20.10.1 TRDSTR Register** of **Notes on Timer RD**.

20.3.3 Timer RD Mode Register (TRDMR) [Timer Mode (in Input Capture Function)]

Address 0138h

Bit	b7	b6	b5	b4	b3	b2	b1	b0
Symbol	BFD1	BFC1	BFD0	BFC0	—	—	—	SYNC
After Reset	0	0	0	0	1	1	1	0

Bit	Symbol	Bit Name	Function	R/W
b0	SYNC	Timer RD synchronous bit	0: Registers TRD0 and TRD1 operate independently 1: Registers TRD0 and TRD1 operate synchronously	R/W
b1	—	Nothing is assigned. If necessary, set to 0. When read, the content is 1.		—
b2	—			
b3	—			
b4	BFC0	TRDGRC0 register function select bit	0: General register 1: Buffer register of TRDGRA0 register	R/W
b5	BFD0	TRDGRD0 register function select bit	0: General register 1: Buffer register of TRDGRB0 register	R/W
b6	BFC1	TRDGRC1 register function select bit	0: General register 1: Buffer register of TRDGRA1 register	R/W
b7	BFD1	TRDGRD1 register function select bit	0: General register 1: Buffer register of TRDGRB1 register	R/W

20.3.4 Timer RD PWM Mode Register (TRDPMR) [Timer Mode (in Input Capture Function)]

Address 0139h

Bit	b7	b6	b5	b4	b3	b2	b1	b0
Symbol	—	PWMD1	PWMC1	PWMB1	—	PWMD0	PWMC0	PWMB0
After Reset	1	0	0	0	1	0	0	0

Bit	Symbol	Bit Name	Function	R/W
b0	PWMB0	PWM mode of TRDIOB0 select bit	Set to 0 (timer mode) in the input capture function.	R/W
b1	PWMC0	PWM mode of TRDIOC0 select bit		R/W
b2	PWMD0	PWM mode of TRDIOD0 select bit		R/W
b3	—	Nothing is assigned. If necessary, set to 0. When read, the content is 1.		—
b4	PWMB1	PWM mode of TRDIOB1 select bit	Set to 0 (timer mode) in the input capture function.	R/W
b5	PWMC1	PWM mode of TRDIOC1 select bit		R/W
b6	PWMD1	PWM mode of TRDIOD1 select bit		R/W
b7	—	Nothing is assigned. If necessary, set to 0. When read, the content is 1.		—

20.3.5 Timer RD Function Control Register (TRDFCR) [Timer Mode (in Input Capture Function)]

Address 013Ah

Bit	b7	b6	b5	b4	b3	b2	b1	b0
Symbol	PWM3	STCLK	ADEG	ADTRG	OLS1	OLS0	CMD1	CMD0
After Reset	1	0	0	0	0	0	0	0

Bit	Symbol	Bit Name	Function	R/W
b0	CMD0	Combination mode select bit ⁽¹⁾	Set to 00b (timer mode, PWM mode, or PWM3 mode) in the input capture function.	R/W
b1	CMD1			R/W
b2	OLS0	Normal-phase output level select bit (in reset synchronous PWM mode or complementary PWM mode)	This bit is disabled in the input capture function.	R/W
b3	OLS1			R/W
b4	ADTRG			R/W
b5	ADEG			R/W
b6	STCLK	External clock input select bit	0: External clock input disabled 1: External clock input enabled	R/W
b7	PWM3	PWM3 mode select bit ⁽²⁾	Set this bit to 1 (other than PWM3 mode) in the input capture function.	R/W

Notes:

- Set bits CMD1 to CMD0 when both the TSTART0 and TSTART1 bits in the TRDSTR register are set to 0 (count stops).
- When bits CMD1 to CMD0 are set to 00b (timer mode, PWM mode, or PWM3 mode), the setting of the PWM3 bit is enabled.

20.3.6 Timer RD Digital Filter Function Select Register i (TRDDFi) (i = 0 or 1) [Timer Mode (in Input Capture Function)]

Address 013Eh (TRDDF0), 013Fh (TRDDF1)

Bit	b7	b6	b5	b4	b3	b2	b1	b0
Symbol	DFCK1	DFCK0	—	—	DFD	DFC	DFB	DFA
After Reset	0	0	0	0	0	0	0	0

Bit	Symbol	Bit Name	Function	R/W
b0	DFA	TRDIOA pin digital filter function select bit	0: Function is not used 1: Function is used	R/W
b1	DFB	TRDIOB pin digital filter function select bit		R/W
b2	DFC	TRDIOC pin digital filter function select bit		R/W
b3	DFD	TRDIOD pin digital filter function select bit		R/W
b4	—	Nothing is assigned. If necessary, set to 0. When read, the content is 0.		—
b5	—			
b6	DFCK0	Clock select bits for digital filter function	b7 b6 0 0: f32 0 1: f8 1 0: f1 1 1: Count source (clock selected by bits TCK2 to TCK0 in the TRDCRi register)	R/W
b7	DFCK1			R/W

20.3.7 Timer RD Control Register i (TRDCRi) (i = 0 or 1) [Timer Mode (in Input Capture Function)]

Address 0140h (TRDCR0), 0150h (TRDCR1)

Bit	b7	b6	b5	b4	b3	b2	b1	b0
Symbol	CCLR2	CCLR1	CCLR0	CKEG1	CKEG0	TCK2	TCK1	TCK0
After Reset	0	0	0	0	0	0	0	0

Bit	Symbol	Bit Name	Function	R/W
b0	TCK0	Count source select bit	b2 b1 b0 0 0 0: f1 0 0 1: f2 0 1 0: f4 0 1 1: f8 1 0 0: f32 1 0 1: TRDCLK input ⁽¹⁾ 1 1 0: fOCO40M 1 1 1: fOCO-F ⁽⁴⁾	R/W
b1	TCK1			R/W
b2	TCK2			R/W
b3	CKEG0	External clock edge select bit ⁽²⁾	b4 b3 0 0: Count at the rising edge 0 1: Count at the falling edge 1 0: Count at both edges 1 1: Do not set.	R/W
b4	CKEG1			R/W
b5	CCLR0	TRDi counter clear select bit	b7 b6 b5 0 0 0: Disable clear (free-running operation) 0 0 1: Clear by input capture in the TRDGRAi register 0 1 0: Clear by input capture in the TRDGRBi register 0 1 1: Synchronous clear (clear simultaneously with other timer RD _i counter) ⁽³⁾ 1 0 0: Do not set. 1 0 1: Clear by input capture in the TRDGRCi register 1 1 0: Clear by input capture in the TRDGRDi register 1 1 1: Do not set.	R/W
b6	CCLR1			R/W
b7	CCLR2			R/W

Notes:

1. Enabled when the ITCLK_i bit in the STCLK bit in the TRDFCR register is 1 (external clock input enabled).
2. Enabled when bits TCK2 to TCK0 are set to 101b (TRDCLK input) and the STCLK bit in the TRDFCR register is set to 1 (external clock input enabled).
3. This setting is enabled when the SYNC bit in the TRDMR register is set to 1 (registers TRD0 and TRD1 operate synchronously).
4. To select fOCO-F, set it to the clock frequency higher than the CPU clock frequency.

20.3.8 Timer RD I/O Control Register Ai (TRDIORAi) (i = 0 or 1) [Timer Mode (in Input Capture Function)]

Address 0141h (TRDIORA0), 0151h (TRDIORA1)

Bit	b7	b6	b5	b4	b3	b2	b1	b0
Symbol	—	IOB2	IOB1	IOB0	IOA3	IOA2	IOA1	IOA0
After Reset	1	0	0	0	1	0	0	0

Bit	Symbol	Bit Name	Function	R/W
b0	IOA0	TRDGRA control bit	^{b1 b0} 0 0: Input capture to the TRDGRAi register at the rising edge 0 1: Input capture to the TRDGRAi register at the falling edge 1 0: Input capture to the TRDGRAi register at both edges 1 1: Do not set.	R/W
b1	IOA1			R/W
b2	IOA2	TRDGRA mode select bit (1)	Set to 1 (input capture) in the input capture function.	R/W
b3	IOA3	Input capture input switch bit (3, 4)	0: fOCO128 Signal 1: TRDIOA0 pin input	R/W
b4	IOB0	TRDGRB control bit	^{b5 b4} 0 0: Input capture to the TRDGRBi register at the rising edge 0 1: Input capture to the TRDGRBi register at the falling edge 1 0: Input capture to the TRDGRBi register at both edges 1 1: Do not set.	R/W
b5	IOB1			R/W
b6	IOB2	TRDGRB mode select bit (2)	Set to 1 (input capture) in the input capture function.	R/W
b7	—	Nothing is assigned. If necessary, set to 0. When read, the content is 1.		—

Notes:

- To select 1 (the TRDGRCi register is used as a buffer register of the TRDGRAi register) for this bit by the BFCi bit in the TRDMR register, set the IOC2 bit in the TRDIORCi register to the same value as the IOA2 bit in the TRDIORAi register.
- To select 1 (the TRDGRDi register is used as a buffer register of the TRDGRBi register) for this bit by the BFDi bit in the TRDMR register, set the IOD2 bit in the TRDIORCi register to the same value as the IOB2 bit in the TRDIORAi register.
- The IOA3 bit is enabled in the TRDIORA0 register only. Set to the IOA3 bit in TRDIORA1 to 1.
- The IOA3 bit is enabled when the IOA2 bit is set to 1 (input capture function).

20.3.9 Timer RD I/O Control Register Ci (TRDIORCi) (i = 0 or 1) [Timer Mode (in Input Capture Function)]

Address 0142h (TRDIORC0), 0152h (TRDIORC1)

Bit	b7	b6	b5	b4	b3	b2	b1	b0
Symbol	IOD3	IOD2	IOD1	IOD0	IOC3	IOC2	IOC1	IOC0
After Reset	1	0	0	0	1	0	0	0

Bit	Symbol	Bit Name	Function	R/W
b0	IOC0	TRDGRC control bit	^{b1 b0} 0 0: Input capture to the TRDGRCi register at the rising edge 0 1: Input capture to the TRDGRCi register at the falling edge 1 0: Input capture to the TRDGRCi register at both edges 1 1: Do not set.	R/W
b1	IOC1			R/W
b2	IOC2	TRDGRC mode select bit ⁽¹⁾	Set to 1 (input capture) in the input capture function.	R/W
b3	IOC3	TRDGRC register function select bit	Set to 1 (general register or buffer register) in the input capture function.	R/W
b4	IOD0	TRDGRD control bit	^{b5 b4} 0 0: Input capture to the TRDGRDi register at the rising edge 0 1: Input capture to the TRDGRDi register at the falling edge 1 0: Input capture to the TRDGRDi register at both edges 1 1: Do not set.	R/W
b5	IOD1			R/W
b6	IOD2	TRDGRD mode select bit ⁽²⁾	Set to 1 (input capture) in the input capture function.	R/W
b7	IOD3	TRDGRD register function select bit	Set to 1 (general register or buffer register) in the input capture function.	R/W

Notes:

- To select 1 (the TRDGRCi register is used as a buffer register of the TRDGRAi register) for this bit by the BFCi bit in the TRDMR register, set the IOC2 bit in the TRDIORCi register to the same value as the IOA2 bit in the TRDIORAi register.
- To select 1 (the TRDGRDi register is used as a buffer register of the TRDGRBi register) for this bit by the BFDi bit in the TRDMR register, set the IOD2 bit in the TRDIORCi register to the same value as the IOB2 bit in the TRDIORAi register.

20.3.10 Timer RD Status Register i (TRDSRi) (i = 0 or 1) [Timer Mode (in Input Capture Function)]

Address 0143h (TRDSR0), 0153h (TRDSR1)

Bit	b7	b6	b5	b4	b3	b2	b1	b0	
Symbol	—	—	UDF	OVF	IMFD	IMFC	IMFB	IMFA	
After Reset	1	1	1	0	0	0	0	0	TRDSR0 register
After Reset	1	1	0	0	0	0	0	0	TRDSR1 register

Bit	Symbol	Bit Name	Function	R/W
b0	IMFA	Input capture / compare match flag A	[Source for setting this bit to 0] Write 0 after read ⁽²⁾ . [Source for setting this bit to 1]. TRDSR0 register: fOCO128 signal edge when the IOA3 bit in the TRDIORA0 register is set to 0 (fOCO128 signal). TRDIOA0 pin input edge when the IOA3 bit in the TRDIORA0 register is set to 1 (TRDIOA0 input) ⁽³⁾ . TRDSR1 register: Input edge of TRDIOA1 pin ⁽³⁾ .	R/W
b1	IMFB	Input capture / compare match flag B	[Source for setting this bit to 0] Write 0 after read ⁽²⁾ . [Source for setting this bit to 1] Input edge of TRDIOBi pin ⁽³⁾ .	R/W
b2	IMFC	Input capture / compare match flag C	[Source for setting this bit to 0] Write 0 after read ⁽²⁾ . [Source for setting this bit to 1] Input edge of TRDIOCi pin ⁽⁴⁾ .	R/W
b3	IMFD	Input capture / compare match flag D	[Source for setting this bit to 0] Write 0 after read ⁽²⁾ . [Source for setting this bit to 1] Input edge of TRDIODi pin ⁽⁴⁾ .	R/W
b4	OVF	Overflow flag	[Source for setting this bit to 0] Write 0 after read ⁽²⁾ . [Source for setting this bit to 1] When the TRDi register overflows.	R/W
b5	UDF	Underflow flag ⁽¹⁾	This bit is disabled in the input capture function.	R/W
b6	—	Nothing is assigned. If necessary, set to 0. When read, the content is 1.		—
b7	—			

Notes:

- Nothing is assigned to b5 in the TRDSR0 register. When writing to b5, write 0. When reading, the content is 1.
- The writing results are as follows:
 - This bit is set to 0 when the read result is 1 and 0 is written to the same bit.
 - This bit remains unchanged even if the read result is 0 and 0 is written to the same bit. (This bit remains 1 even if it is set to 1 from 0 after reading, and writing 0.)
 - This bit remains unchanged if 1 is written to it.
- Edge selected by bits IOj1 to IOj0 (j = A or B) in the TRDIORAi register.
- Edge selected by bits IOk1 to IOk0 (k = C or D) in the TRDIORCi register.
Including when the BFki bit in the TRDMR register is set to 1 (TRDGRki is used as the buffer register).

20.3.11 Timer RD Interrupt Enable Register i (TRDIERi) (i = 0 or 1) [Timer Mode (in Input Capture Function)]

Address 0144h (TRDIER0), 0154h (TRDIER1)

Bit	b7	b6	b5	b4	b3	b2	b1	b0
Symbol	—	—	—	OVIE	IMIED	IMIEC	IMIEB	IMIEA
After Reset	1	1	1	0	0	0	0	0

Bit	Symbol	Bit Name	Function	R/W
b0	IMIEA	Input capture/compare match interrupt enable bit A	0: Disable interrupt (IMIA) by the IMFA bit 1: Enable interrupt (IMIA) by the IMFA bit	R/W
b1	IMIEB	Input capture/compare match interrupt enable bit B	0: Disable interrupt (IMIB) by the IMFB bit 1: Enable interrupt (IMIB) by the IMFB bit	R/W
b2	IMIEC	Input capture/compare match interrupt enable bit C	0: Disable interrupt (IMIC) by the IMFC bit 1: Enable interrupt (IMIC) by the IMFC bit	R/W
b3	IMIED	Input capture/compare match interrupt enable bit D	0: Disable interrupt (IMID) by the IMFD bit 1: Enable interrupt (IMID) by the IMFD bit	R/W
b4	OVIE	Overflow/underflow interrupt enable bit	0: Disable interrupt (OVI) by the OVF bit 1: Enable interrupt (OVI) by the OVF bit	R/W
b5	—	Nothing is assigned. If necessary, set to 0. When read, the content is 1.		—
b6	—			
b7	—			
b7	—			

20.3.12 Timer RD Counter i (TRDi) (i = 0 or 1) [Timer Mode (in Input Capture Function)]

Address 0147h to 0146h (TRD0), 0157h to 0156h (TRD1)

Bit	b7	b6	b5	b4	b3	b2	b1	b0
Symbol	—	—	—	—	—	—	—	—
After Reset	0	0	0	0	0	0	0	0

Bit	b15	b14	b13	b12	b11	b10	b9	b8
Symbol	—	—	—	—	—	—	—	—
After Reset	0	0	0	0	0	0	0	0

Bit	Function	Setting Range	R/W
b15 to b0	Count the count source. Count operation is incremented. When an overflow occurs, the OVF bit in the TRDSRi register is set to 1.	0000h to FFFFh	R/W

Access the TRDi register in 16-bit units. Do not access it in 8-bit units.

20.3.13 Timer RD General Registers Ai, Bi, Ci, and Di (TRDGRAi, TRDGRBi, TRDGRCi, TRDGRDi) (i = 0 or 1) [Timer Mode (in Input Capture Function)]

Address 0149h to 0148h (TRDGRA0), 014Bh to 014Ah (TRDGRB0),
014Dh to 014Ch (TRDGRC0), 014Fh to 014Eh (TRDGRD0),
0159h to 0158h (TRDGRA1), 015Bh to 015Ah (TRDGRB1),
015Dh to 015Ch (TRDGRC1), 015Fh to 015Eh (TRDGRD1)

Bit	b7	b6	b5	b4	b3	b2	b1	b0
Symbol	—	—	—	—	—	—	—	—
After Reset	1	1	1	1	1	1	1	1

Bit	b15	b14	b13	b12	b11	b10	b9	b8
Symbol	—	—	—	—	—	—	—	—
After Reset	1	1	1	1	1	1	1	1

Bit	Function	R/W
b15 to b0	Refer to Table 20.6 TRDGRji Register Functions in Input Capture Function	R/W

Access registers TRDGRAi to TRDGRDi in 16-bit units. Do not access them in 8-bit units.

The following registers are disabled in the input capture function: TRDOER1, TRDOER2, TRDOCR, TRDPOCR0, and TRDPOCR1.

Table 20.6 TRDGRji Register Functions in Input Capture Function

Register	Setting	Register Function	Input-Capture Input Pin
TRDGRAi	—	General register The value in the TRDi register can be read at input capture.	TRDIOAi
TRDGRBi	—		TRDIOBi
TRDGRCi	BFCi = 0	General register The value in the TRDi register can be read at input capture.	TRDIOCi
TRDGRDi	BFDi = 0		TRDIODi
TRDGRCi	BFCi = 1	Buffer register The value in the TRDi register can be read at input capture. (Refer to 20.2.2 Buffer Operation.)	TRDIOAi
TRDGRDi	BFDi = 1		TRDIOBi

i = 0 or 1, j = A, B, C, or D

BFCi, BFDi: Bits in TRDMR register

Set the pulse width of the input capture signal applied to the TRDIOji pin to 3 cycles or more of the timer RD operation clock (refer to **Table 20.1 Timer RD Operation Clocks**) for no digital filter (the DFj bit in the TRDDFi register set to 0).

20.3.14 Timer RD Pin Select Register 0 (TRDPSR0)

Address 0184h

Bit	b7	b6	b5	b4	b3	b2	b1	b0
Symbol	—	TRDIOD0SELO	—	TRDIOC0SELO	—	TRDIOB0SELO	—	TRDIOA0SELO
After Reset	0	0	0	0	0	0	0	0

Bit	Symbol	Bit Name	Function	R/W
b0	TRDIOA0SELO	TRDIOA0/TRDCLK pin select bit	0: TRDIOA0/TRDCLK pin not used 1: P3_5 assigned	R/W
b1	—	Nothing is assigned. If necessary, set to 0. When read, the content is 0.		—
b2	TRDIOB0SELO	TRDIOB0 pin select bit	0: TRDIOB0 pin not used 1: P3_4 assigned	R/W
b3	—	Reserved bit	Set to 0.	R/W
b4	TRDIOC0SELO	TRDIOC0 pin select bit	0: TRDIOC0 pin not used 1: P3_7 assigned	R/W
b5	—	Reserved bit	Set to 0.	R/W
b6	TRDIOD0SELO	TRDIOD0 pin select bit	0: TRDIOD0 pin not used 1: P3_3 assigned	R/W
b7	—	Nothing is assigned. If necessary, set to 0. When read, the content is 0.		—

The TRDPSR0 register selects which pin is assigned to the timer RD I/O. To use the I/O pin for timer RD, set this register.

Set the TRDPSR0 register before setting the timer RD associated registers. Also, do not change the setting value in this register during timer RD operation.

20.3.15 Timer RD Pin Select Register 1 (TRDPSR1)

Address 0185h

Bit	b7	b6	b5	b4	b3	b2	b1	b0
Symbol	—	TRDIOD1SELO	—	TRDIOC1SELO	—	TRDIOB1SELO	—	TRDIOA1SELO
After Reset	0	0	0	0	0	0	0	0

Bit	Symbol	Bit Name	Function	R/W
b0	TRDIOA1SELO	TRDIOA1 pin select bit	0: TRDIOA1 pin not used 1: P1_0 assigned	R/W
b1	—	Nothing is assigned. If necessary, set to 0. When read, the content is 0.		—
b2	TRDIOB1SELO	TRDIOB1 pin select bit	0: TRDIOB1 pin not used 1: P1_1 assigned	R/W
b3	—	Nothing is assigned. If necessary, set to 0. When read, the content is 0.		—
b4	TRDIOC1SELO	TRDIOC1 pin select bit	0: TRDIOC1 pin not used 1: P1_2 assigned	R/W
b5	—	Reserved bit	Set to 0.	R/W
b6	TRDIOD1SELO	TRDIOD1 pin select bit	0: TRDIOD1 pin not used 1: P1_3 assigned	R/W
b7	—	Reserved bit	Set to 0.	R/W

The TRDPSR1 register selects which pin is assigned to the timer RD I/O. To use the I/O pin for timer RD, set this register.

Set the TRDPSR1 register before setting the timer RD associated registers. Also, do not change the setting value in this register during timer RD operation.

20.3.16 Operating Example

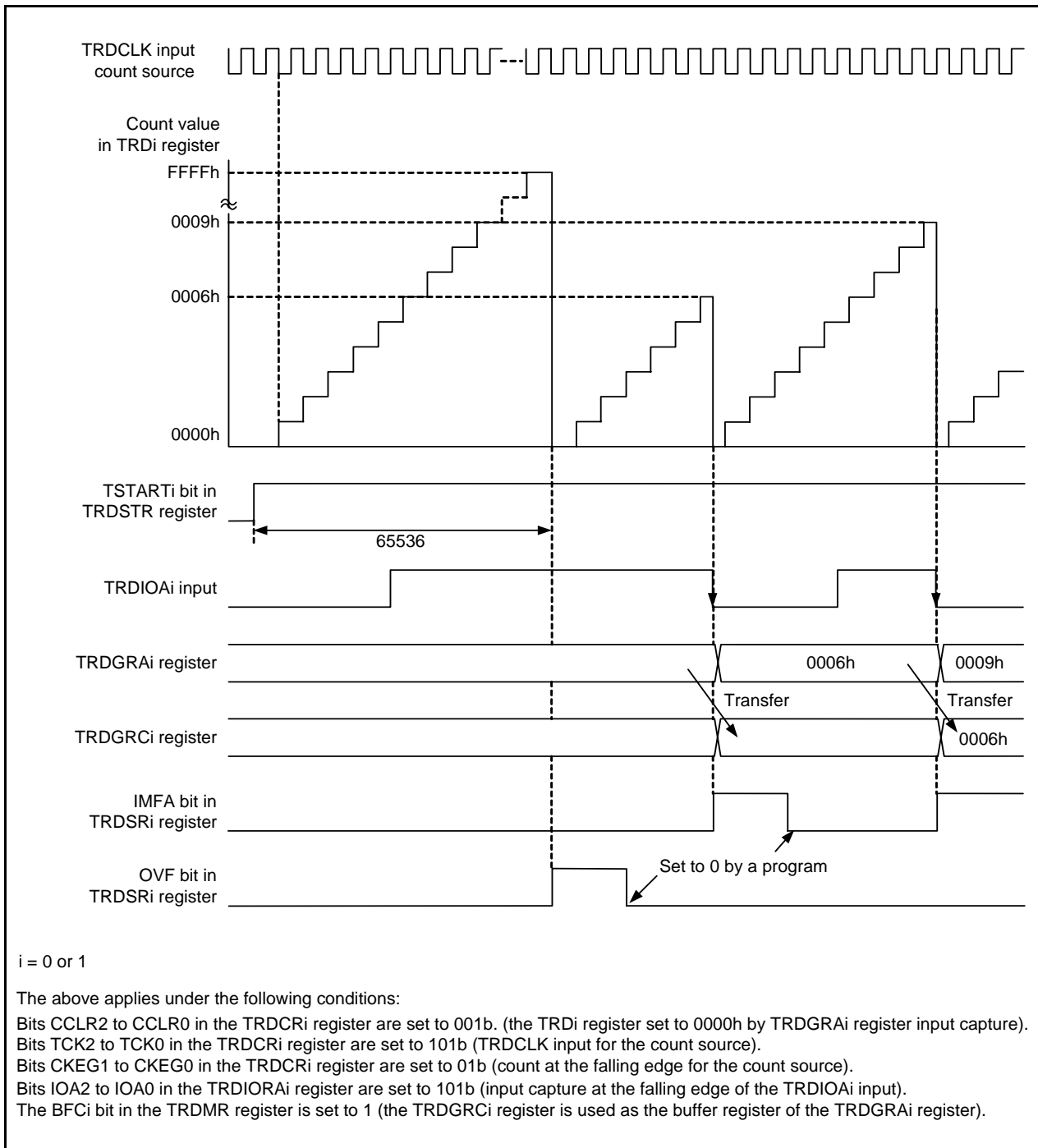

Figure 20.8 Operating Example of Input Capture Function

20.3.17 Digital Filter

The TRDIO_j_i (i = 0 or 1, j = A, B, C or D) input is sampled, and when the sampled input level matches 3 times, its level is determined. Select the digital filter function and sampling clock by the TRDDFi register. Figure 20.9 shows a Block Diagram of Digital Filter.

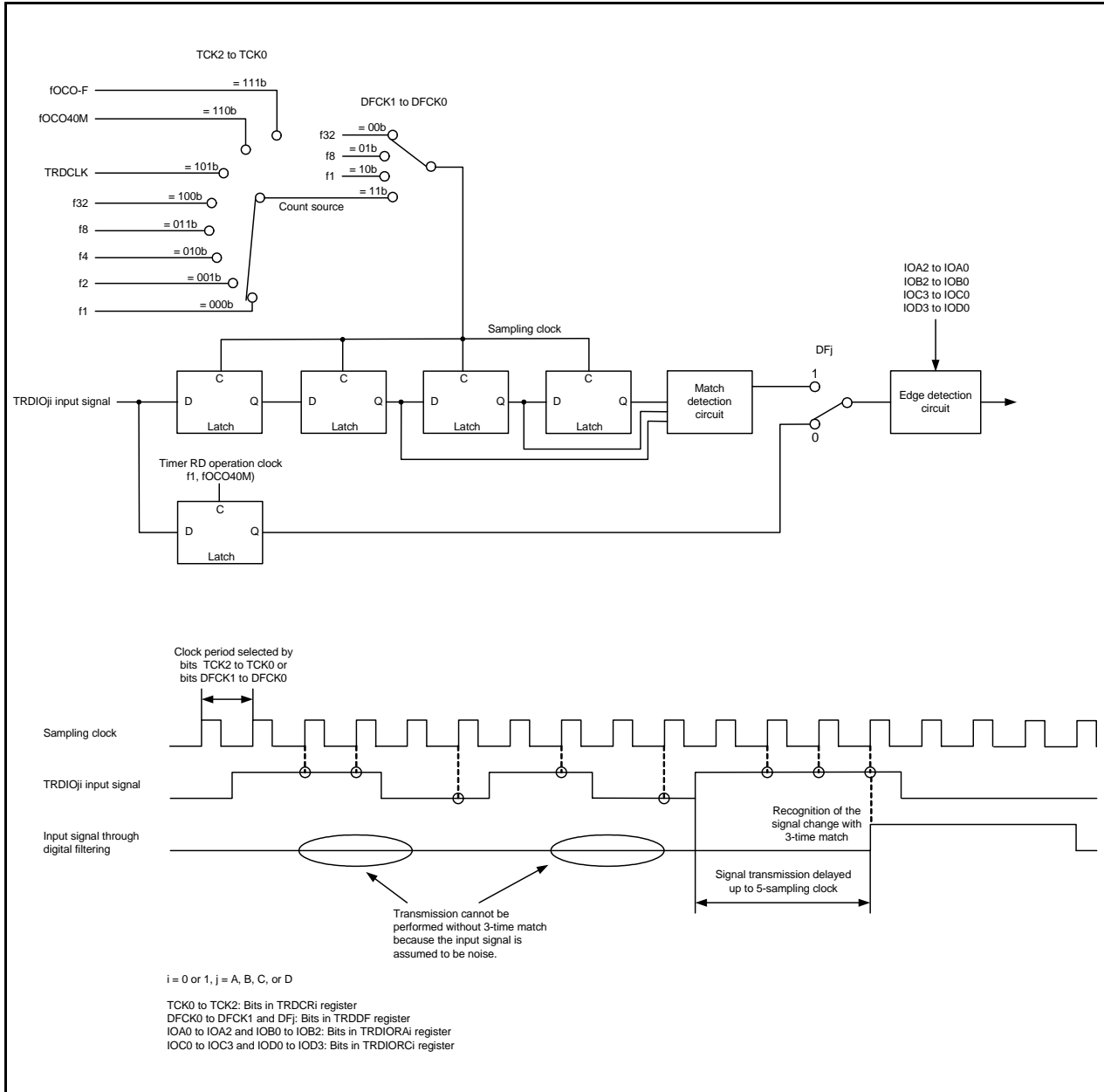

Figure 20.9 Block Diagram of Digital Filter

20.4 Timer Mode (Output Compare Function)

This function detects matches (compare match) between the content of the TRDGR_{ji} (j = A, B, C, or D) register and the content of the TRD_i (i = 0 or 1) register. When the content matches, a user-set level is output from the TRDIO_{ji} pin. Since this function is enabled with a combination of the TRDIO_{ji} pin and TRDGR_{ji} register, the output compare function, or any other mode or function, can be selected for each individual pin. Figure 20.10 shows a Block Diagram of Output Compare Function, Table 20.7 lists the Output Compare Function Specifications. Figure 20.11 shows an Operating Example of Output Compare Function.

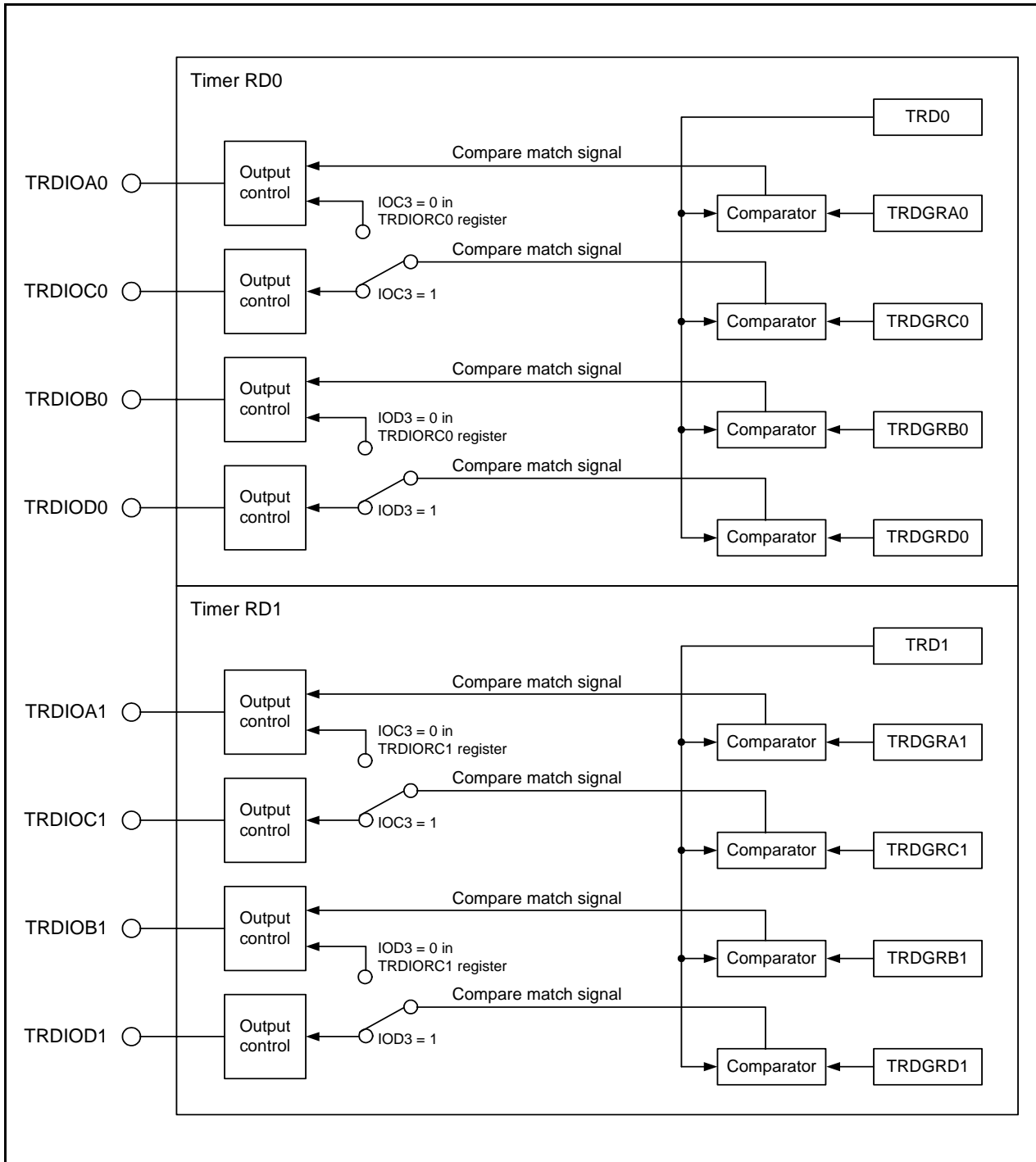

Figure 20.10 Block Diagram of Output Compare Function

Table 20.7 Output Compare Function Specifications

Item	Specification
Count sources	f1, f2, f4, f8, f32, fOCO40M, fOCO-F External signal input to the TRDCLK pin (valid edge selected by a program)
Count operations	Increment
Count period	<ul style="list-style-type: none"> When bits CCLR2 to CCLR0 in the TRDCR_i register are set to 000b (free-running operation). 1/fk × 65536 fk: Frequency of count source Bits CCLR1 to CCLR0 in the TRDCR_i register are set to 01b or 10b (set the TRD_i register to 0000h at the compare match in the TRDGR_{ji} register). Frequency of count source × (n+1) n: Setting value in the TRDGR_{ji} register
Waveform output timing	Compare match
Count start condition	1 (count starts) is written to the TSTART _i bit in the TRDSTR register.
Count stop conditions	<ul style="list-style-type: none"> 0 (count stops) is written to the TSTART_i bit in the TRDSTR register when the CSEL_i bit in the TRDSTR register is set to 1. The output compare output pin holds output level before the count stops. When the CSEL_i bit in the TRDSTR register is set to 0, the count stops at the compare match in the TRDGRA_i register. The output compare output pin holds level after output change by the compare match.
Interrupt request generation timing	<ul style="list-style-type: none"> Compare match (The content of the TRD_i register matches content of the TRDGR_{ji} register.) TRD_i register overflows
TRDIOA0 pin function	Programmable I/O port, output-compare output, or TRDCLK (external clock) input
TRDIOB0, TRDIOC0, TRDIOD0, TRDIOA1 to TRDIOD1 pin functions	Programmable I/O port or output-compare output (Selectable by pin)
INT0 pin function	Programmable I/O port, pulse output forced cutoff signal input, or INT0 interrupt input
Read from timer	The count value can be read by reading the TRD _i register.
Write to timer	<ul style="list-style-type: none"> When the SYNC bit in the TRDMR register is set to 0 (timer RD0 and timer RD1 operate independently). Data can be written to the TRD_i register. When the SYNC bit in the TRDMR register is set to 1 (timer RD0 and timer RD1 operate synchronously). Data can be written to both the TRD0 and TRD1 registers by writing to the TRD_i register.
Selectable functions	<ul style="list-style-type: none"> Output-compare output pin selection Either 1 pin or multiple pins among TRDIOA_i, TRDIOB_i, TRDIOC_i, or TRDIOD_i. Output level at the compare match selection “L” output, “H” output, or output level inverted Initial output level selected Set the level at period from the count start to the compare match. Timing for setting the TRD_i register to 0000h Overflow or compare match in the TRDGRA_i register Buffer operation (Refer to 20.2.2 Buffer Operation.) Synchronous operation (Refer to 20.2.3 Synchronous Operation.) Changing output pins for registers TRDGRC_i and TRDGRD_i The TRDGRC_i register can be used as output control of the TRDIOA_i pin and the TRDGRD_i register can be used as output control of the TRDIOB_i pin. Pulse output forced cutoff signal input (Refer to 20.2.4 Pulse Output Forced Cutoff.) Timer RD can be used as the internal timer without output. A/D trigger generation

i = 0 or 1, j = A, B, C, or D

20.4.1 Module Standby Control Register (MSTCR)

Address 0008h

Bit	b7	b6	b5	b4	b3	b2	b1	b0
Symbol	—	—	MSTTRC	MSTTRD	MSTIIC	—	—	—
After Reset	0	0	0	0	0	0	0	0

Bit	Symbol	Bit Name	Function	R/W
b0	—	Nothing is assigned. If necessary, set to 0. When read, the content is 0.		—
b1	—			
b2	—			
b3	MSTIIC	SSU standby bit	0: Active 1: Standby ⁽¹⁾	R/W
b4	MSTTRD	Timer RD standby bit	0: Active 1: Standby ^(2, 3)	R/W
b5	MSTTRC	Timer RC standby bit	0: Active 1: Standby ⁽⁴⁾	R/W
b6	—	Reserved bit	Set to 0.	R/W
b7	—	Nothing is assigned. If necessary, set to 0. When read, the content is 0.		—

Notes:

1. Stop the SSU and the I²C bus functions before setting to standby. When the MSTIIC bit is set to 1 (standby), any access to the SSU associated registers (addresses 0193h to 019Dh) is disabled.
2. Stop the timer RD function before setting to standby. When the MSTTRD bit is set to 1 (standby), any access to the timer RD associated registers (addresses 0135h to 015Fh) is disabled.
3. To set the MSTTRD bit to 1 (standby), set bits TCK2 to TCK0 in the TRDCR_i (i = 0 or 1) register to 000b (f1).
4. Stop the timer RC function before setting to standby. When the MSTTRC bit is set to 1 (standby), any access to the timer RC associated registers (addresses 0120h to 0133h) is disabled.

20.4.2 Timer RD Trigger Control Register (TRDADCR)

Address 0136h

Bit	b7	b6	b5	b4	b3	b2	b1	b0
Symbol	ADTRGD1E	ADTRGC1E	ADTRGB1E	ADTRGA1E	ADTRGD0E	ADTRGC0E	ADTRGB0E	ADTRGA0E
After Reset	0	0	0	0	0	0	0	0

Bit	Symbol	Bit Name	Function	R/W
b0	ADTRGA0E	A/D trigger A0 enable bit	0: A/D trigger disabled 1: A/D trigger generated at compare match with registers TRD0 and TRDGRA0	R/W
b1	ADTRGB0E	A/D trigger B0 enable bit	0: A/D trigger disabled 1: A/D trigger generated at compare match with registers TRD0 and TRDGRB0	R/W
b2	ADTRGC0E	A/D trigger C0 enable bit	0: A/D trigger disabled 1: A/D trigger generated at compare match with registers TRD0 and TRDGRC0	R/W
b3	ADTRGD0E	A/D trigger D0 enable bit	0: A/D trigger disabled 1: A/D trigger generated at compare match with registers TRD0 and TRDGRD0	R/W
b4	ADTRGA1E	A/D trigger A1 enable bit	0: A/D trigger disabled 1: A/D trigger generated at compare match with registers TRD1 and TRDGRA1	R/W
b5	ADTRGB1E	A/D trigger B1 enable bit	0: A/D trigger disabled 1: A/D trigger generated at compare match with registers TRD1 and TRDGRB1	R/W
b6	ADTRGC1E	A/D trigger C1 enable bit	0: A/D trigger disabled 1: A/D trigger generated at compare match with registers TRD1 and TRDGRC1	R/W
b7	ADTRGD1E	A/D trigger D1 enable bit	0: A/D trigger disabled 1: A/D trigger generated at compare match with registers TRD1 and TRDGRD1	R/W

20.4.3 Timer RD Start Register (TRDSTR) [Timer Mode (in Output Compare Function)]

Address 0137h

Bit	b7	b6	b5	b4	b3	b2	b1	b0
Symbol	—	—	—	—	CSEL1	CSEL0	TSTART1	TSTART0
After Reset	1	1	1	1	1	1	0	0

Bit	Symbol	Bit Name	Function	R/W
b0	TSTART0	TRD0 count start flag ⁽³⁾	0: Count stops ⁽¹⁾ 1: Count starts	R/W
b1	TSTART1	TRD1 count start flag ⁽⁴⁾	0: Count stops ⁽²⁾ 1: Count starts	R/W
b2	CSEL0	TRD0 count operation select bit	0: Count stops at the compare match with the TRDGRA0 register 1: Count continues after the compare match with the TRDGRA0 register	R/W
b3	CSEL1	TRD1 count operation select bit	0: Count stops at the compare match with the TRDGRA1 register 1: Count continues after the compare match with the TRDGRA1 register	R/W
b4	—	Nothing is assigned. If necessary, set to 0. When read, the content is 1.		—
b5	—			
b6	—			
b7	—			

Notes:

1. When the CSEL0 bit is set to 1, write 0 to the TSTART0 bit.
2. When the CSEL1 bit is set to 1, write 0 to the TSTART1 bit.
3. When the CSEL0 bit is set to 0 and the compare match signal (TRDIOA0) is generated, this bit is set to 0 (count stops).
4. When the CSEL1 bit is set to 0 and the compare match signal (TRDIOA1) is generated, this bit is set to 0 (count stops).

Set the TRDSTR register using the MOV instruction (do not use the bit handling instruction). Refer to **20.10.1 TRDSTR Register** of **Notes on Timer RD**.

20.4.4 Timer RD Mode Register (TRDMR) [Timer Mode (in Output Compare Function)]

Address 0138h

Bit	b7	b6	b5	b4	b3	b2	b1	b0
Symbol	BFD1	BFC1	BFD0	BFC0	—	—	—	SYNC
After Reset	0	0	0	0	1	1	1	0

Bit	Symbol	Bit Name	Function	R/W
b0	SYNC	Timer RD synchronous bit	0: Registers TRD0 and TRD1 operate independently 1: Registers TRD0 and TRD1 operate synchronously	R/W
b1	—	Nothing is assigned. If necessary, set to 0. When read, the content is 1.		—
b2	—			
b3	—			
b4	BFC0	TRDGRC0 register function select bit ⁽¹⁾	0: General register 1: Buffer register of TRDGRA0 register	R/W
b5	BFD0	TRDGRD0 register function select bit ⁽¹⁾	0: General register 1: Buffer register of TRDGRB0 register	R/W
b6	BFC1	TRDGRC1 register function select bit ⁽¹⁾	0: General register 1: Buffer register of TRDGRA1 register	R/W
b7	BFD1	TRDGRD1 register function select bit ⁽¹⁾	0: General register 1: Buffer register of TRDGRB1 register	R/W

Note:

- When selecting 0 (change the TRDGR_ji register output pin) by the IO_j3 (j = C or D) bit in the TRDIORC_i (i = 0 or 1) register, set the BF_ji bit in the TRDMR register to 0.

20.4.5 Timer RD PWM Mode Register (TRDPMR) [Timer Mode (in Output Compare Function)]

Address 0139h

Bit	b7	b6	b5	b4	b3	b2	b1	b0
Symbol	—	PWMD1	PWMC1	PWMB1	—	PWMD0	PWMC0	PWMB0
After Reset	1	0	0	0	1	0	0	0

Bit	Symbol	Bit Name	Function	R/W
b0	PWMB0	PWM mode of TRDIOB0 select bit	Set to 0 (timer mode) in the output compare function.	R/W
b1	PWMC0	PWM mode of TRDIOC0 select bit		R/W
b2	PWMD0	PWM mode of TRDIOD0 select bit		R/W
b3	—	Nothing is assigned. If necessary, set to 0. When read, the content is 1.	—	—
b4	PWMB1	PWM mode of TRDIOB1 select bit	Set to 0 (timer mode) in the output compare function.	R/W
b5	PWMC1	PWM mode of TRDIOC1 select bit		R/W
b6	PWMD1	PWM mode of TRDIOD1 select bit		R/W
b7	—	Nothing is assigned. If necessary, set to 0. When read, the content is 1.	—	—

20.4.6 Timer RD Function Control Register (TRDFCR) [Timer Mode (in Output Compare Function)]

Address 013Ah

Bit	b7	b6	b5	b4	b3	b2	b1	b0
Symbol	PWM3	STCLK	ADEG	ADTRG	OLS1	OLS0	CMD1	CMD0
After Reset	1	0	0	0	0	0	0	0

Bit	Symbol	Bit Name	Function	R/W
b0	CMD0	Combination mode select bit ⁽¹⁾	Set to 00b (timer mode, PWM mode, or PWM3 mode) in the output compare function.	R/W
b1	CMD1			R/W
b2	OLS0	Normal-phase output level select bit (in reset synchronous PWM mode or complementary PWM mode)	This bit is disabled in the output compare function.	R/W
b3	OLS1	Counter-phase output level select bit (in reset synchronous PWM mode or complementary PWM mode)		R/W
b4	ADTRG	A/D trigger enable bit (in complementary PWM mode)		R/W
b5	ADEG	A/D trigger edge select bit (in complementary PWM mode)		R/W
b6	STCLK	External clock input select bit	0: External clock input disabled 1: External clock input enabled	R/W
b7	PWM3	PWM3 mode select bit ⁽²⁾	Set this bit to 1 (other than PWM3 mode) in the output compare function.	R/W

Notes:

1. Set bits CMD1 to CMD0 when both the TSTART0 and TSTART1 bits in the TRDSTR register are set to 0 (count stops).
2. When bits CMD1 to CMD0 are set to 00b (timer mode, PWM mode, or PWM3 mode), the setting of the PWM3 bit is enabled.

20.4.7 Timer RD Output Master Enable Register 1 (TRDOER1) [Timer Mode (in Output Compare Function)]

Address 013Bh

Bit	b7	b6	b5	b4	b3	b2	b1	b0
Symbol	ED1	EC1	EB1	EA1	ED0	EC0	EB0	EA0
After Reset	1	1	1	1	1	1	1	1

Bit	Symbol	Bit Name	Function	R/W
b0	EA0	TRDIOA0 output disable bit	0: Enable output 1: Disable output (The TRDIOA0 pin is used as a programmable I/O port.)	R/W
b1	EB0	TRDIOB0 output disable bit	0: Enable output 1: Disable output (The TRDIOB0 pin is used as a programmable I/O port.)	R/W
b2	EC0	TRDIOC0 output disable bit	0: Enable output 1: Disable output (The TRDIOC0 pin is used as a programmable I/O port.)	R/W
b3	ED0	TRDIOD0 output disable bit	0: Enable output 1: Disable output (The TRDIOD0 pin is used as a programmable I/O port.)	R/W
b4	EA1	TRDIOA1 output disable bit	0: Enable output 1: Disable output (The TRDIOA1 pin is used as a programmable I/O port.)	R/W
b5	EB1	TRDIOB1 output disable bit	0: Enable output 1: Disable output (The TRDIOB1 pin is used as a programmable I/O port.)	R/W
b6	EC1	TRDIOC1 output disable bit	0: Enable output 1: Disable output (The TRDIOC1 pin is used as a programmable I/O port.)	R/W
b7	ED1	TRDIOD1 output disable bit	0: Enable output 1: Disable output (The TRDIOD1 pin is used as a programmable I/O port.)	R/W

20.4.8 Timer RD Output Master Enable Register 2 (TRDOER2) [Timer Mode (in Output Compare Function)]

Address 013Ch

Bit	b7	b6	b5	b4	b3	b2	b1	b0
Symbol	PTO	—	—	—	—	—	—	—
After Reset	0	1	1	1	1	1	1	1

Bit	Symbol	Bit Name	Function	R/W
b0	—	Nothing is assigned. If necessary, set to 0. When read, the content is 1.		—
b1	—			
b2	—			
b3	—			
b4	—			
b5	—			
b6	—			
b7	PTO	$\overline{\text{INT0}}$ of pulse output forced cutoff signal input enabled bit ⁽¹⁾	0: Pulse output forced cutoff input disabled 1: Pulse output forced cutoff input enabled (All bits in the TRDOER1 register are set to <u>1</u> (disable output) when "L" is applied to the $\overline{\text{INT0}}$ pin.)	R/W

Note:

1. Refer to **20.2.4 Pulse Output Forced Cutoff**.

20.4.9 Timer RD Output Control Register (TRDOCR) [Timer Mode (in Output Compare Function)]

Address 013Dh

Bit	b7	b6	b5	b4	b3	b2	b1	b0
Symbol	TOD1	TOC1	TOB1	TOA1	TOD0	TOC0	TOB0	TOA0
After Reset	0	0	0	0	0	0	0	0

Bit	Symbol	Bit Name	Function	R/W
b0	TOA0	TRDIOA0 output level select bit	0: Initial output "L" 1: Initial output "H"	R/W
b1	TOB0	TRDIOB0 output level select bit	0: Initial output "L" 1: Initial output "H"	R/W
b2	TOC0	TRDIOC0 initial output level select bit	0: "L" 1: "H"	R/W
b3	TOD0	TRDIOD0 initial output level select bit		R/W
b4	TOA1	TRDIOA1 initial output level select bit		R/W
b5	TOB1	TRDIOB1 initial output level select bit		R/W
b6	TOC1	TRDIOC1 initial output level select bit		R/W
b7	TOD1	TRDIOD1 initial output level select bit		R/W

Write to the TRDOCR register when both the TSTART0 and TSTART1 bits in the TRDSTR register are set to 0 (count stopped).

If the pin function is set for waveform output (refer to **7.5 Port Settings**), the initial output level is output when the TRDOCR register is set.

20.4.10 Timer RD Control Register i (TRDCRi) (i = 0 or 1) [Timer Mode (in Output Compare Function)]

Address 0140h (TRDCR0), 0150h (TRDCR1)

Bit	b7	b6	b5	b4	b3	b2	b1	b0
Symbol	CCLR2	CCLR1	CCLR0	CKEG1	CKEG0	TCK2	TCK1	TCK0
After Reset	0	0	0	0	0	0	0	0

Bit	Symbol	Bit Name	Function	R/W
b0	TCK0	Count source select bit	b2 b1 b0 0 0 0: f1 0 0 1: f2 0 1 0: f4 0 1 1: f8 1 0 0: f32 1 0 1: TRDCLK input ⁽¹⁾ 1 1 0: fOCO40M 1 1 1: fOCO-F ⁽⁴⁾	R/W
b1	TCK1			R/W
b2	TCK2			R/W
b3	CKEG0	External clock edge select bit ⁽²⁾	b4 b3 0 0: Count at the rising edge 0 1: Count at the falling edge 1 0: Count at both edges 1 1: Do not set.	R/W
b4	CKEG1			R/W
b5	CCLR0	TRDi counter clear select bit	b7 b6 b5 0 0 0: Disable clear (free-running operation) 0 0 1: Clear by compare match with the TRDGRAi register 0 1 0: Clear by compare match with the TRDGRBi register 0 1 1: Synchronous clear (clear simultaneously with other timer RDi counter) ⁽³⁾ 1 0 0: Do not set. 1 0 1: Clear by compare match with the TRDGRCi register 1 1 0: Clear by compare match with the TRDGRDi register 1 1 1: Do not set.	R/W
b6	CCLR1			R/W
b7	CCLR2			R/W

Notes:

1. Enabled when the STCLK bit in the TRDFCR register is 1 (external clock input enabled).
2. Enabled when bits TCK2 to TCK0 are set to 101b (TRDCLK input) and the STCLK bit in the TRDFCR register is set to 1 (external clock input enabled).
3. This setting is enabled when the SYNC bit in the TRDMR register is set to 1 (registers TRD0 and TRD1 operate synchronously).
4. To select fOCO-F, set it to the clock frequency higher than the CPU clock frequency.

20.4.11 Timer RD I/O Control Register Ai (TRDIORAi) (i = 0 or 1) [Timer Mode (in Output Compare Function)]

Address 0141h (TRDIORA0), 0151h (TRDIORA1)

Bit	b7	b6	b5	b4	b3	b2	b1	b0
Symbol	—	IOB2	IOB1	IOB0	IOA3	IOA2	IOA1	IOA0
After Reset	1	0	0	0	1	0	0	0

Bit	Symbol	Bit Name	Function	R/W
b0	IOA0	TRDGRA control bit	^{b1 b0} 0 0: Disable pin output by the compare match (TRDIOAi pin functions as programmable I/O port) 0 1: "L" output by compare match with the TRDGRAi register 1 0: "H" output by compare match with the TRDGRAi register 1 1: Toggle output by compare match with the TRDGRAi register	R/W
b1	IOA1			R/W
b2	IOA2	TRDGRA mode select bit ⁽¹⁾	Set to 0 (output compare) in the output compare function.	R/W
b3	IOA3	Input capture input switch bit	Set to 1.	R/W
b4	IOB0	TRDGRB control bit	^{b5 b4} 0 0: Disable pin output by the compare match (TRDIOBi pin functions as programmable I/O port) 0 1: "L" output by compare match with the TRDGRBi register 1 0: "H" output by compare match with the TRDGRBi register 1 1: Toggle output by compare match with the TRDGRBi register	R/W
b5	IOB1			R/W
b6	IOB2	TRDGRB mode select bit ⁽²⁾	Set to 0 (output compare) in the output compare function.	R/W
b7	—	Nothing is assigned. If necessary, set to 0. When read, the content is 1.		—

Notes:

- To select 1 (the TRDGRCi register is used as a buffer register of the TRDGRAi register) for this bit by the BFCi bit in the TRDMR register, set the IOC2 bit in the TRDIORCi register to the same value as the IOA2 bit in the TRDIORAi register.
- To select 1 (the TRDGRDi register is used as a buffer register of the TRDGRBi register) for this bit by the BFDi bit in the TRDMR register, set the IOD2 bit in the TRDIORCi register to the same value as the IOB2 bit in the TRDIORAi register.

20.4.12 Timer RD I/O Control Register Ci (TRDIORCi) (i = 0 or 1) [Timer Mode (in Output Compare Function)]

Address 0142h (TRDIORC0), 0152h (TRDIORC1)

Bit	b7	b6	b5	b4	b3	b2	b1	b0
Symbol	IOD3	IOD2	IOD1	IOD0	IOC3	IOC2	IOC1	IOC0
After Reset	1	0	0	0	1	0	0	0

Bit	Symbol	Bit Name	Function	R/W
b0	IOC0	TRDGRC control bit	^{b1 b0} 0 0: Disable pin output by compare match 0 1: "L" output by compare match with the TRDGRCi register 1 0: "H" output by compare match with the TRDGRCi register 1 1: Toggle output by compare match with the TRDGRCi register	R/W
b1	IOC1			R/W
b2	IOC2	TRDGRC mode select bit ⁽¹⁾	Set to 0 (output compare) in the output compare function.	R/W
b3	IOC3	TRDGRC register function select bit	0: TRDIOA output register (Refer to 20.4.20 Changing Output Pins in Registers TRDGRCi (i = 0 or 1) and TRDGRDi.) 1: General register or buffer register	R/W
b4	IOD0	TRDGRD control bit	^{b5 b4} 0 0: Disable pin output by compare match 0 1: "L" output by compare match with the TRDGRDi register 1 0: "H" output by compare match with the TRDGRDi register 1 1: Toggle output by compare match with the TRDGRDi register	R/W
b5	IOD1			R/W
b6	IOD2	TRDGRD mode select bit ⁽²⁾	Set to 0 (output compare) in the output compare function.	R/W
b7	IOD3	TRDGRD register function select bit	0: TRDIOB output register (Refer to 20.4.20 Changing Output Pins in Registers TRDGRCi (i = 0 or 1) and TRDGRDi.) 1: General register or buffer register	R/W

Notes:

- To select 1 (the TRDGRCi register is used as a buffer register of the TRDGRAi register) for this bit by the BFCi bit in the TRDMR register, set the IOC2 bit in the TRDIORCi register to the same value as the IOA2 bit in the TRDIORAi register.
- To select 1 (the TRDGRDi register is used as a buffer register of the TRDGRBi register) for this bit by the BFDi bit in the TRDMR register, set the IOD2 bit in the TRDIORCi register to the same value as the IOB2 bit in the TRDIORAi register.

20.4.13 Timer RD Status Register i (TRDSRi) (i = 0 or 1) [Timer Mode (in Output Compare Function)]

Address 0143h (TRDSR0), 0153h (TRDSR1)

Bit	b7	b6	b5	b4	b3	b2	b1	b0	
Symbol	—	—	UDF	OVF	IMFD	IMFC	IMFB	IMFA	
After Reset	1	1	1	0	0	0	0	0	TRDSR0 register
After Reset	1	1	0	0	0	0	0	0	TRDSR1 register

Bit	Symbol	Bit Name	Function	R/W
b0	IMFA	Input capture / compare match flag A	[Source for setting this bit to 0] Write 0 after read ⁽²⁾ [Source for setting this bit to 1] When the value in the TRDi register matches with the value in the TRDGRAi register.	R/W
b1	IMFB	Input capture / compare match flag B	[Source for setting this bit to 0] Write 0 after read ⁽²⁾ [Source for setting this bit to 1] When the value in the TRDi register matches with the value in the TRDGRBi register.	R/W
b2	IMFC	Input capture / compare match flag C	[Source for setting this bit to 0] Write 0 after read ⁽²⁾ [Source for setting this bit to 1] When the value in the TRDi register matches with the value in the TRDGRCi register ⁽³⁾ .	R/W
b3	IMFD	Input capture / compare match flag D	[Source for setting this bit to 0] Write 0 after read ⁽²⁾ [Source for setting this bit to 1] When the value in the TRDi register matches with the value in the TRDGRDi register ⁽³⁾ .	R/W
b4	OVF	Overflow flag	[Source for setting this bit to 0] Write 0 after read ⁽²⁾ [Source for setting this bit to 1] When the TRDi register overflows.	R/W
b5	UDF	Underflow flag ⁽¹⁾	This bit is disabled in the output compare function.	R/W
b6	—	Nothing is assigned. If necessary, set to 0. When read, the content is 1.		—
b7	—			

Notes:

- Nothing is assigned to b5 in the TRDSR0 register. When writing to b5, write 0. When reading, the content is 1.
- The writing results are as follows:
 - This bit is set to 0 when the read result is 1 and 0 is written to the same bit.
 - This bit remains unchanged even if the read result is 0 and 0 is written to the same bit. (This bit remains 1 even if it is set to 1 from 0 after reading, and writing 0.)
 - This bit remains unchanged if 1 is written to it.
- Including when the BFji bit in the TRDMR register is set to 1 (TRDGRji is used as the buffer register).

20.4.14 Timer RD Interrupt Enable Register i (TRDIERi) (i = 0 or 1) [Timer Mode (in Output Compare Function)]

Address 0144h (TRDIER0), 0154h (TRDIER1)

Bit	b7	b6	b5	b4	b3	b2	b1	b0
Symbol	—	—	—	OVIE	IMIED	IMIEC	IMIEB	IMIEA
After Reset	1	1	1	0	0	0	0	0

Bit	Symbol	Bit Name	Function	R/W
b0	IMIEA	Input capture/compare match interrupt enable bit A	0: Disable interrupt (IMIA) by the IMFA bit 1: Enable interrupt (IMIA) by the IMFA bit	R/W
b1	IMIEB	Input capture/compare match interrupt enable bit B	0: Disable interrupt (IMIB) by the IMFB bit 1: Enable interrupt (IMIB) by the IMFB bit	R/W
b2	IMIEC	Input capture/compare match interrupt enable bit C	0: Disable interrupt (IMIC) by the IMFC bit 1: Enable interrupt (IMIC) by the IMFC bit	R/W
b3	IMIED	Input capture/compare match interrupt enable bit D	0: Disable interrupt (IMID) by the IMFD bit 1: Enable interrupt (IMID) by the IMFD bit	R/W
b4	OVIE	Overflow/underflow interrupt enable bit	0: Disable interrupt (OVI) by the OVF bit 1: Enable interrupt (OVI) by the OVF bit	R/W
b5	—	Nothing is assigned. If necessary, set to 0. When read, the content is 1.		—
b6	—			
b7	—			
b7	—			

20.4.15 Timer RD Counter i (TRDi) (i = 0 or 1) [Timer Mode (in Output Compare Function)]

Address 0147h to 0146h (TRD0), 0157h to 0156h (TRD1)

Bit	b7	b6	b5	b4	b3	b2	b1	b0
Symbol	—	—	—	—	—	—	—	—
After Reset	0	0	0	0	0	0	0	0

Bit	b15	b14	b13	b12	b11	b10	b9	b8
Symbol	—	—	—	—	—	—	—	—
After Reset	0	0	0	0	0	0	0	0

Bit	Function	Setting Range	R/W
b15 to b0	Count the count source. Count operation is incremented. When an overflow occurs, the OVF bit in the TRDSRi register is set to 1.	0000h to FFFFh	R/W

Access the TRDi register in 16-bit units. Do not access it in 8-bit units.

20.4.16 Timer RD General Registers Ai, Bi, Ci, and Di (TRDGRAi, TRDGRBi, TRDGRCi, TRDGRDi) (i = 0 or 1) [Timer Mode (in Output Compare Function)]

Address 0149h to 0148h (TRDGRA0), 014Bh to 014Ah (TRDGRB0),
014Dh to 014Ch (TRDGRC0), 014Fh to 014Eh (TRDGRD0),
0159h to 0158h (TRDGRA1), 015Bh to 015Ah (TRDGRB1),
015Dh to 015Ch (TRDGRC1), 015Fh to 015Eh (TRDGRD1)

Bit	b7	b6	b5	b4	b3	b2	b1	b0
Symbol	—	—	—	—	—	—	—	—
After Reset	1	1	1	1	1	1	1	1

Bit	b15	b14	b13	b12	b11	b10	b9	b8
Symbol	—	—	—	—	—	—	—	—
After Reset	1	1	1	1	1	1	1	1

Bit	Function	R/W
b15 to b0	Refer to Table 20.8 TRDGRji Register Function in Output Compare Function	R/W

Access registers TRDGRAi to TRDGRDi in 16-bit units. Do not access them in 8-bit units.

The following registers are disabled in the output compare function: TRDDF0, TRDDF1, TRDPOCR0, and TRDPOCR1.

Table 20.8 TRDGRji Register Function in Output Compare Function

Register	Setting		Register Function	Output-Compare Output Pin	
	BFji	IOj3			
TRDGRAi	—	—	General register. Write the compare value.	TRDIOAi	
TRDGRBi				TRDIOBi	
TRDGRCi	0	1	General register. Write the compare value.	TRDIOCi	
TRDGRDi				TRDIODi	
TRDGRCi	1	1	Buffer register. Write the next compare value (Refer to 20.2.2 Buffer Operation .)	TRDIOAi	
TRDGRDi				TRDIOBi	
TRDGRCi	0	0	TRDIOAi output control	(Refer to 20.4.20 Changing Output Pins in Registers TRDGRCi (i = 0 or 1) and TRDGRDi .)	TRDIOAi
TRDGRDi			TRDIOBi output control		TRDIOBi

i = 0 or 1, j = A, B, C, or D

BFji: Bit in TRDMR register, IOj3: Bit in TRDIORCi register

20.4.17 Timer RD Pin Select Register 0 (TRDPSR0)

Address 0184h

Bit	b7	b6	b5	b4	b3	b2	b1	b0
Symbol	—	TRDIOD0SELO	—	TRDIOC0SELO	—	TRDIOB0SELO	—	TRDIOA0SELO
After Reset	0	0	0	0	0	0	0	0

Bit	Symbol	Bit Name	Function	R/W
b0	TRDIOA0SELO	TRDIOA0/TRDCLK pin select bit	0: TRDIOA0/TRDCLK pin not used 1: P3_5 assigned	R/W
b1	—	Nothing is assigned. If necessary, set to 0. When read, the content is 0.		—
b2	TRDIOB0SELO	TRDIOB0 pin select bit	0: TRDIOB0 pin not used 1: P3_4 assigned	R/W
b3	—	Reserved bit	Set to 0.	R/W
b4	TRDIOC0SELO	TRDIOC0 pin select bit	0: TRDIOC0 pin not used 1: P3_7 assigned	R/W
b5	—	Reserved bit	Set to 0.	R/W
b6	TRDIOD0SELO	TRDIOD0 pin select bit	0: TRDIOD0 pin not used 1: P3_3 assigned	R/W
b7	—	Nothing is assigned. If necessary, set to 0. When read, the content is 0.		—

The TRDPSR0 register selects which pin is assigned to the timer RD I/O. To use the I/O pin for timer RD, set this register.

Set the TRDPSR0 register before setting the timer RD associated registers. Also, do not change the setting value in this register during timer RD operation.

20.4.18 Timer RD Pin Select Register 1 (TRDPSR1)

Address 0185h

Bit	b7	b6	b5	b4	b3	b2	b1	b0
Symbol	—	TRDIOD1SELO	—	TRDIOC1SELO	—	TRDIOB1SELO	—	TRDIOA1SELO
After Reset	0	0	0	0	0	0	0	0

Bit	Symbol	Bit Name	Function	R/W
b0	TRDIOA1SELO	TRDIOA1 pin select bit	0: TRDIOA1 pin not used 1: P1_0 assigned	R/W
b1	—	Nothing is assigned. If necessary, set to 0. When read, the content is 0.		—
b2	TRDIOB1SELO	TRDIOB1 pin select bit	0: TRDIOB1 pin not used 1: P1_1 assigned	R/W
b3	—	Nothing is assigned. If necessary, set to 0. When read, the content is 0.		—
b4	TRDIOC1SELO	TRDIOC1 pin select bit	0: TRDIOC1 pin not used 1: P1_2 assigned	R/W
b5	—	Reserved bit	Set to 0.	R/W
b6	TRDIOD1SELO	TRDIOD1 pin select bit	0: TRDIOD1 pin not used 1: P1_3 assigned	R/W
b7	—	Reserved bit	Set to 0.	R/W

The TRDPSR1 register selects which pin is assigned to the timer RD I/O. To use the I/O pin for timer RD, set this register.

Set the TRDPSR1 register before setting the timer RD associated registers. Also, do not change the setting value in this register during timer RD operation.

20.4.19 Operating Example

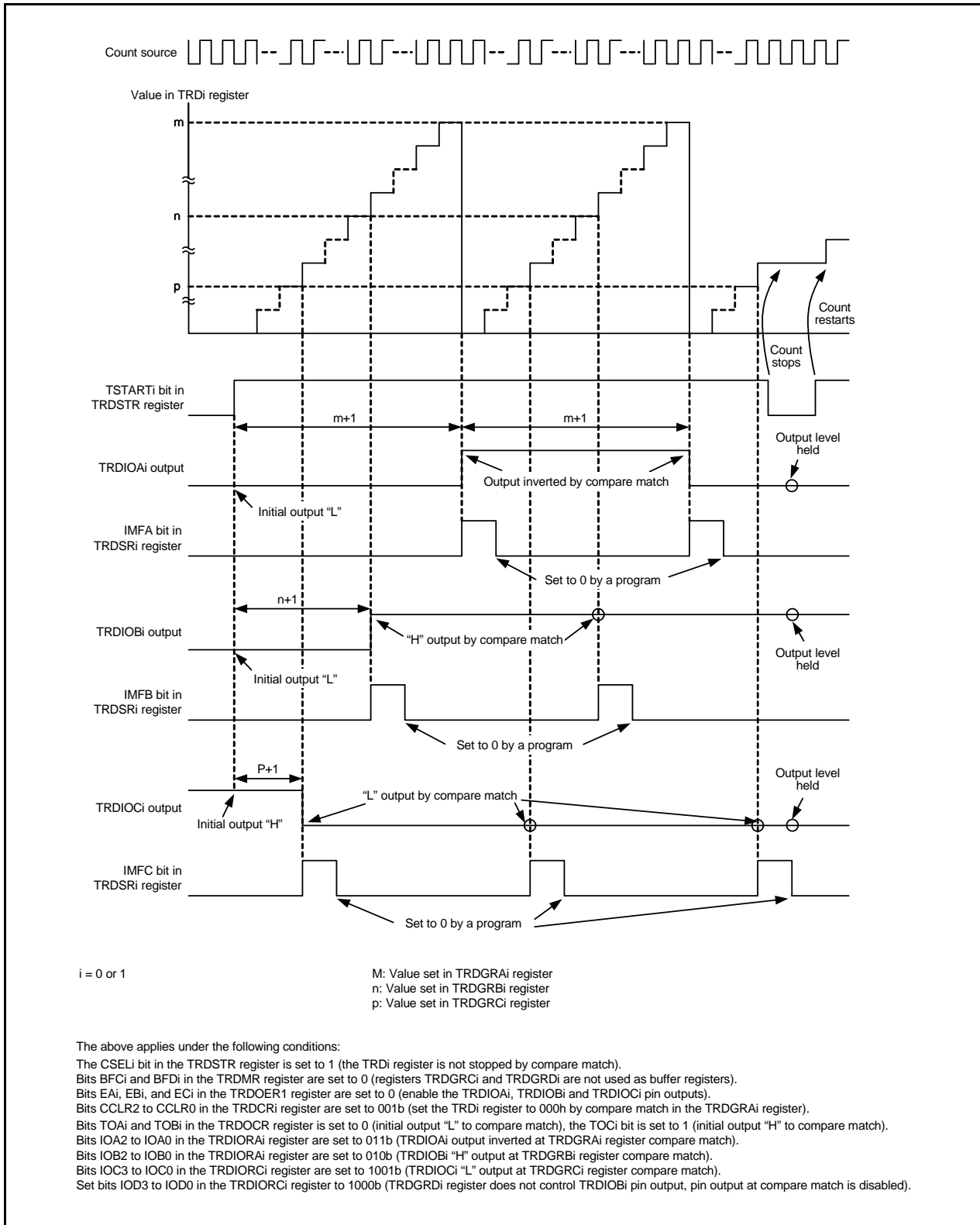

Figure 20.11 Operating Example of Output Compare Function

20.4.20 Changing Output Pins in Registers TRDGRCi (i = 0 or 1) and TRDGRDi

The TRDGRCi register can be used for output control of the TRDIOAi pin, and the TRDGRDi register can be used for output control of the TRDIOBi pin. Therefore, each pin output can be controlled as follows:

- TRDIOAi output is controlled by the values in registers TRDGRAi and TRDGRCi.
- TRDIOBi output is controlled by the values in registers TRDGRBi and TRDGRDi.

Change output pins in registers TRDGRCi and TRDGRDi as follows:

- Select 0 (change TRDGRji register output pin) by the IOj3 (j = C or D) bit in the TRDIORCi register.
- Set the BFji bit in the TRDMR register to 0 (general register).
- Set different values in registers TRDGRCi and TRDGRAi. Also, set different values in registers TRDGRDi and TRDGRBi.

Figure 20.13 shows an Operating Example When TRDGRCi Register is Used for Output Control of TRDIOAi Pin and TRDGRDi Register is Used for Output Control of TRDIOBi Pin.

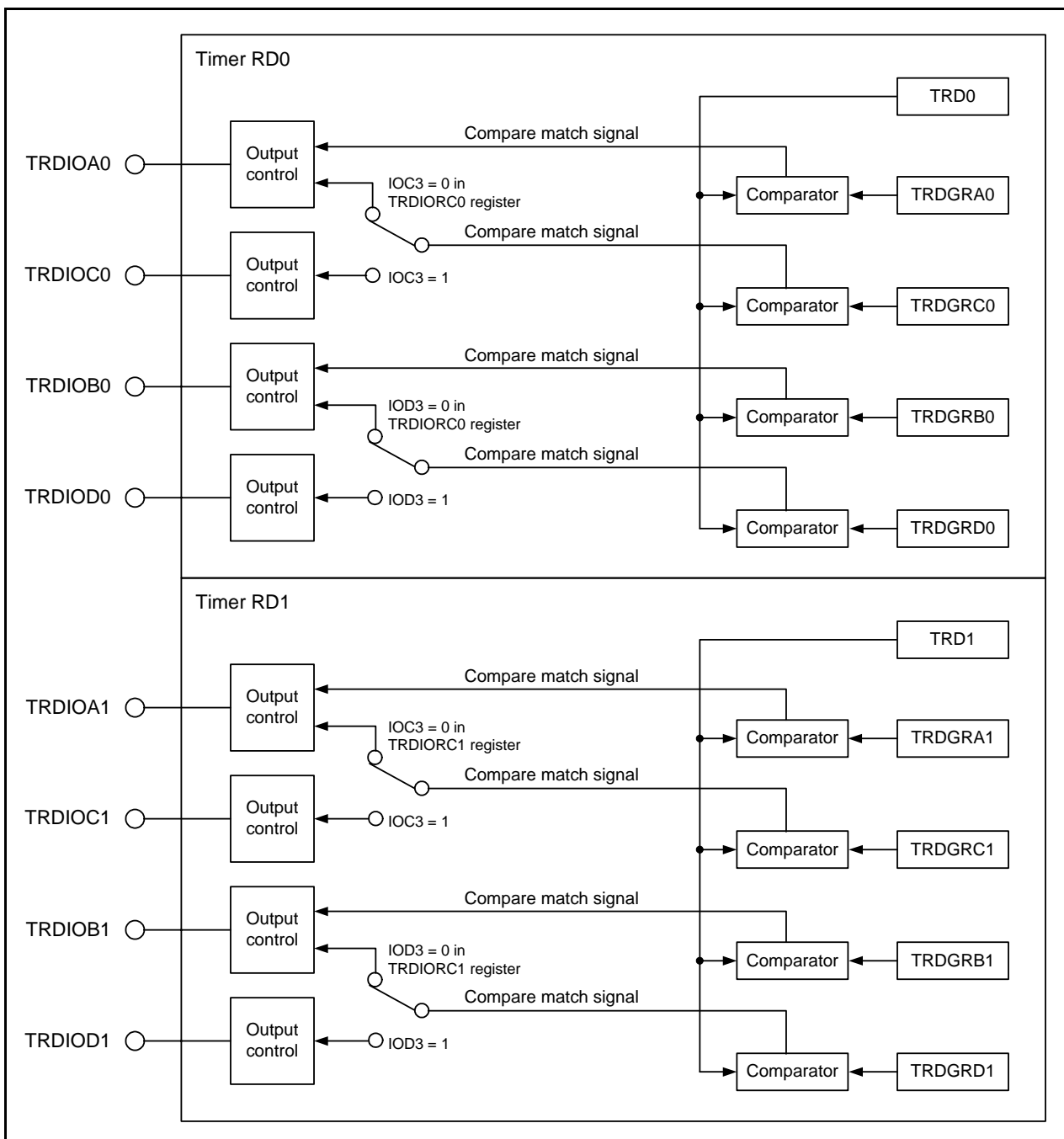

Figure 20.12 Changing Output Pins in Registers TRDGRCi and TRDGRDi

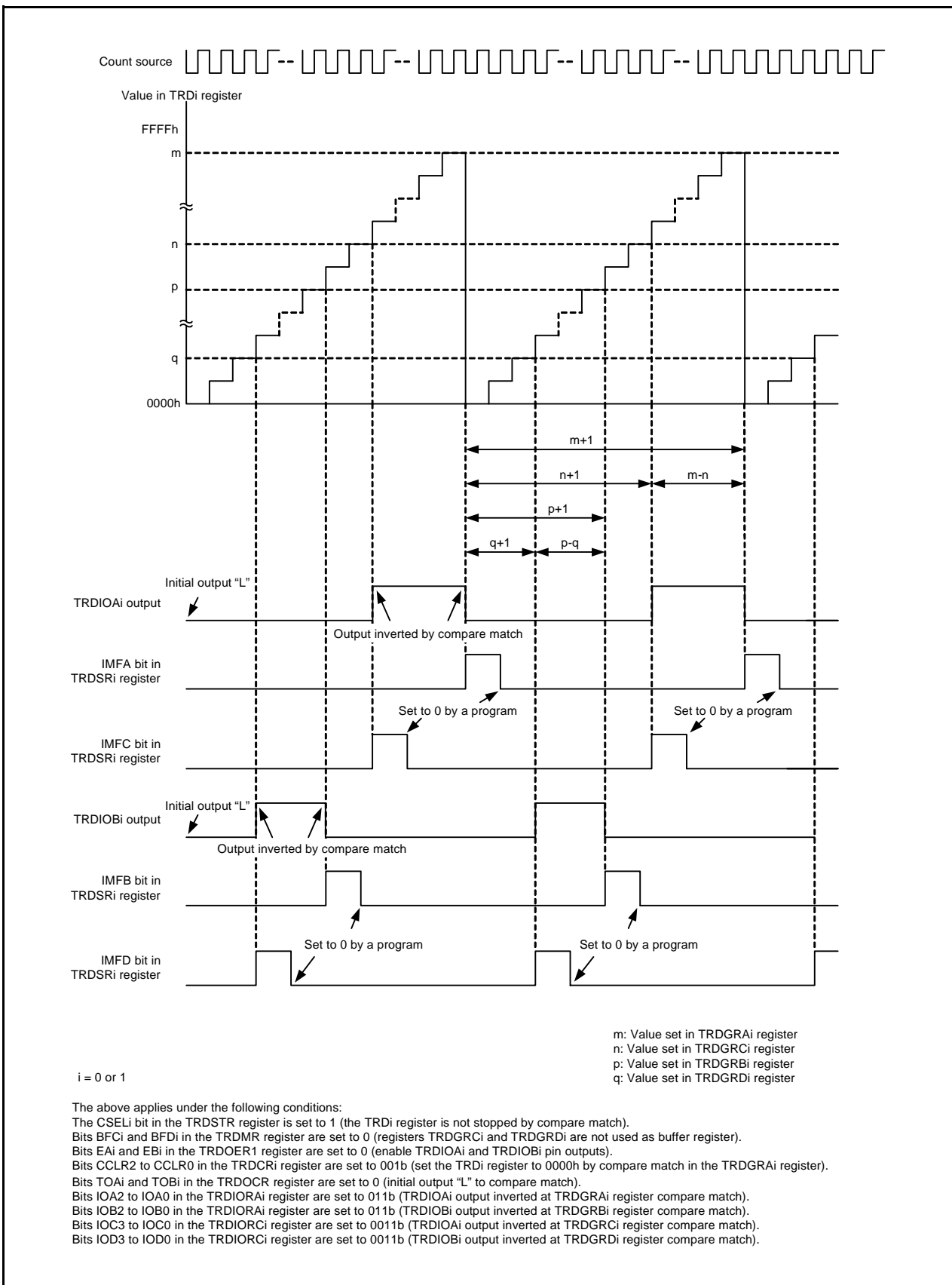

Figure 20.13 Operating Example When TRDGRGi Register is Used for Output Control of TRDIOAi Pin and TRDGRDi Register is Used for Output Control of TRDIOBi Pin

20.4.21 A/D Trigger Generation

A compare match signal with registers TRDi (i = 0 or 1) and TRDGRji (j = A, B, C, or D) can be used as the conversion start trigger of the A/D converter.

The TRDADCR register is used to select which compare match is used.

20.5 PWM Mode

In PWM mode, a PWM waveform is output. Up to 3 PWM waveforms with the same period can be output by timer RD_i ($i = 0$ or 1). Also, up to 6 PWM waveforms with the same period can be output by synchronizing timer RD0 and timer RD1. Since this mode functions by a combination of the TRDIO_{ji} ($i = 0$ or 1 , $j = B, C$, or D) pin and TRDGR_{ji} register, the PWM mode, or any other mode or function, can be selected for each individual pin. (However, since the TRDGRA_i register is used when using any pin for PWM mode, the TRDGRA_i register cannot be used for other modes.)

Figure 20.14 shows a Block Diagram of PWM Mode, and Table 20.9 lists the PWM Mode Specifications. Figures 20.15 and 20.16 show the Operations of PWM Mode.

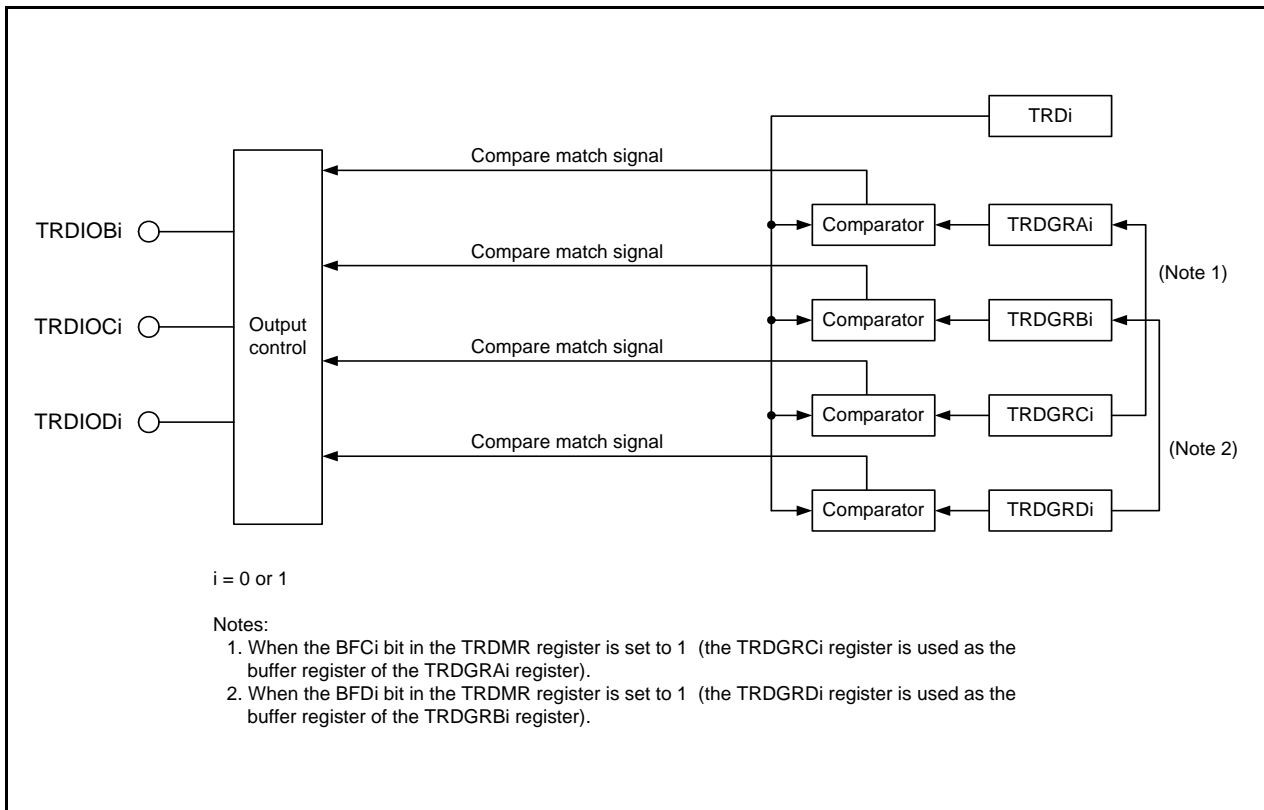
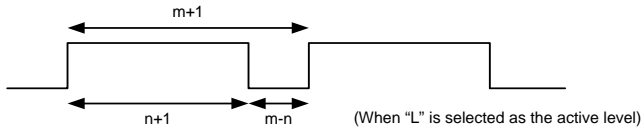

Figure 20.14 Block Diagram of PWM Mode

Table 20.9 PWM Mode Specifications

Item	Specification
Count sources	f1, f2, f4, f8, f32, fOCO40M, fOCO-F External signal input to the TRDCLK pin (valid edge selected by a program)
Count operations	Increment
PWM waveform	<p>PWM period: $1/f_k \times (m+1)$ Active level width: $1/f_k \times (m-n)$ Inactive level width: $1/f_k \times (n+1)$ f_k: Frequency of count source m: Value set in the TRDGRAi register n: Value set in the TRDGRji register</p>  <p>(When "L" is selected as the active level)</p>
Count start condition	1 (count starts) is written to the TSTARTi bit in the TRDSTR register.
Count stop conditions	<ul style="list-style-type: none"> • 0 (count stops) is written to the TSTARTi bit in the TRDSTR register when the CSELi bit in the TRDSTR register is set to 1. The PWM output pin holds output level before the count stops. • When the CSELi bit in the TRDSTR register is set to 0, the count stops at the compare match in the TRDGRAi register. The PWM output pin holds level after output change by compare match.
Interrupt request generation timing	<ul style="list-style-type: none"> • Compare match (The content of the TRDi register matches content of the TRDGRhi register.) • TRDi register overflows
TRDIOA0 pin function	Programmable I/O port or TRDCLK (external clock) input
TRDIOA1 pin function	Programmable I/O port
TRDIOB0, TRDIOC0, TRDIOD0, TRDIOB1, TRDIOC1, TRDIOD1 pin functions	Programmable I/O port or pulse output (selectable by pin)
INT0 pin function	Programmable I/O port, pulse output forced cutoff signal input, or INT0 interrupt input
Read from timer	The count value can be read by reading the TRDi register.
Write to timer	The value can be written to the TRDi register.
Selectable functions	<ul style="list-style-type: none"> • One to three PWM output pins selectable with timer RD_i Either 1 pin or multiple pins of the TRDIOBi, TRDIOCi or TRDIODi pin. • Active level selectable for each pin. • Initial output level selectable for each pin. • Synchronous operation (Refer to 20.2.3 Synchronous Operation.) • Buffer operation (Refer to 20.2.2 Buffer Operation.) • Pulse output forced cutoff signal input (Refer to 20.2.4 Pulse Output Forced Cutoff.) • A/D trigger generation

i = 0 or 1

j = B, C, or D

h = A, B, C, or D

20.5.1 Module Standby Control Register (MSTCR)

Address 0008h

Bit	b7	b6	b5	b4	b3	b2	b1	b0
Symbol	—	—	MSTTRC	MSTTRD	MSTIIC	—	—	—
After Reset	0	0	0	0	0	0	0	0

Bit	Symbol	Bit Name	Function	R/W
b0	—	Nothing is assigned. If necessary, set to 0. When read, the content is 0.		—
b1	—			
b2	—			
b3	MSTIIC	SSU standby bit	0: Active 1: Standby ⁽¹⁾	R/W
b4	MSTTRD	Timer RD standby bit	0: Active 1: Standby ^(2, 3)	R/W
b5	MSTTRC	Timer RC standby bit	0: Active 1: Standby ⁽⁴⁾	R/W
b6	—	Reserved bit	Set to 0.	R/W
b7	—	Nothing is assigned. If necessary, set to 0. When read, the content is 0.		—

Notes:

1. Stop the SSU and the I²C bus functions before setting to standby. When the MSTIIC bit is set to 1 (standby), any access to the SSU associated registers (addresses 0193h to 019Dh) is disabled.
2. Stop the timer RD function before setting to standby. When the MSTTRD bit is set to 1 (standby), any access to the timer RD associated registers (addresses 0135h to 015Fh) is disabled.
3. To set the MSTTRD bit to 1 (standby), set bits TCK2 to TCK0 in the TRDCR_i (i = 0 or 1) register to 000b (f1).
4. Stop the timer RC function before setting to standby. When the MSTTRC bit is set to 1 (standby), any access to the timer RC associated registers (addresses 0120h to 0133h) is disabled.

20.5.2 Timer RD Trigger Control Register (TRDADCR)

Address 0136h

Bit	b7	b6	b5	b4	b3	b2	b1	b0
Symbol	ADTRGD1E	ADTRGC1E	ADTRGB1E	ADTRGA1E	ADTRGD0E	ADTRGC0E	ADTRGB0E	ADTRGA0E
After Reset	0	0	0	0	0	0	0	0

Bit	Symbol	Bit Name	Function	R/W
b0	ADTRGA0E	A/D trigger A0 enable bit	0: A/D trigger disabled 1: A/D trigger generated at compare match with registers TRD0 and TRDGRA0	R/W
b1	ADTRGB0E	A/D trigger B0 enable bit	0: A/D trigger disabled 1: A/D trigger generated at compare match with registers TRD0 and TRDGRB0	R/W
b2	ADTRGC0E	A/D trigger C0 enable bit	0: A/D trigger disabled 1: A/D trigger generated at compare match with registers TRD0 and TRDGRC0	R/W
b3	ADTRGD0E	A/D trigger D0 enable bit	0: A/D trigger disabled 1: A/D trigger generated at compare match with registers TRD0 and TRDGRD0	R/W
b4	ADTRGA1E	A/D trigger A1 enable bit	0: A/D trigger disabled 1: A/D trigger generated at compare match with registers TRD1 and TRDGRA1	R/W
b5	ADTRGB1E	A/D trigger B1 enable bit	0: A/D trigger disabled 1: A/D trigger generated at compare match with registers TRD1 and TRDGRB1	R/W
b6	ADTRGC1E	A/D trigger C1 enable bit	0: A/D trigger disabled 1: A/D trigger generated at compare match with registers TRD1 and TRDGRC1	R/W
b7	ADTRGD1E	A/D trigger D1 enable bit	0: A/D trigger disabled 1: A/D trigger generated at compare match with registers TRD1 and TRDGRD1	R/W

20.5.3 Timer RD Start Register (TRDSTR) in PWM Mode

Address 0137h

Bit	b7	b6	b5	b4	b3	b2	b1	b0
Symbol	—	—	—	—	CSEL1	CSEL0	TSTART1	TSTART0
After Reset	1	1	1	1	1	1	0	0

Bit	Symbol	Bit Name	Function	R/W
b0	TSTART0	TRD0 count start flag ⁽³⁾	0: Count stops ⁽¹⁾ 1: Count starts	R/W
b1	TSTART1	TRD1 count start flag ⁽⁴⁾	0: Count stops ⁽²⁾ 1: Count starts	R/W
b2	CSEL0	TRD0 count operation select bit	0: Count stops at the compare match with the TRDGRA0 register 1: Count continues after the compare match with the TRDGRA0 register	R/W
b3	CSEL1	TRD1 count operation select bit	0: Count stops at the compare match with the TRDGRA1 register 1: Count continues after the compare match with the TRDGRA1 register	R/W
b4	—	Nothing is assigned. If necessary, set to 0. When read, the content is 1.		—
b5	—			
b6	—			
b7	—			

Notes:

1. When the CSEL0 bit is set to 1, write 0 to the TSTART0 bit.
2. When the CSEL1 bit is set to 1, write 0 to the TSTART1 bit.
3. When the CSEL0 bit is set to 0 and the compare match signal (TRDIOA0) is generated, this bit is set to 0 (count stops).
4. When the CSEL1 bit is set to 0 and the compare match signal (TRDIOA1) is generated, this bit is set to 0 (count stops).

Set the TRDSTR register using the MOV instruction (do not use the bit handling instruction). Refer to **20.10.1 TRDSTR Register** of **Notes on Timer RD**.

20.5.4 Timer RD Mode Register (TRDMR) in PWM Mode

Address 0138h

Bit	b7	b6	b5	b4	b3	b2	b1	b0
Symbol	BFD1	BFC1	BFD0	BFC0	—	—	—	SYNC
After Reset	0	0	0	0	1	1	1	0

Bit	Symbol	Bit Name	Function	R/W
b0	SYNC	Timer RD synchronous bit	0: Registers TRD0 and TRD1 operate independently 1: Registers TRD0 and TRD1 operate synchronously	R/W
b1	—	Nothing is assigned. If necessary, set to 0. When read, the content is 1.		—
b2	—			
b3	—			
b4	BFC0	TRDGRC0 register function select bit	0: General register 1: Buffer register of TRDGRA0 register	R/W
b5	BFD0	TRDGRD0 register function select bit	0: General register 1: Buffer register of TRDGRB0 register	R/W
b6	BFC1	TRDGRC1 register function select bit	0: General register 1: Buffer register of TRDGRA1 register	R/W
b7	BFD1	TRDGRD1 register function select bit	0: General register 1: Buffer register of TRDGRB1 register	R/W

20.5.5 Timer RD PWM Mode Register (TRDPMR) in PWM Mode

Address 0139h

Bit	b7	b6	b5	b4	b3	b2	b1	b0
Symbol	—	PWMD1	PWMC1	PWMB1	—	PWMD0	PWMC0	PWMB0
After Reset	1	0	0	0	1	0	0	0

Bit	Symbol	Bit Name	Function	R/W
b0	PWMB0	PWM mode of TRDIOB0 select bit	0: Timer mode 1: PWM mode	R/W
b1	PWMC0	PWM mode of TRDIOC0 select bit		R/W
b2	PWMD0	PWM mode of TRDIOD0 select bit		R/W
b3	—	Nothing is assigned. If necessary, set to 0. When read, the content is 1.		—
b4	PWMB1	PWM mode of TRDIOB1 select bit	0: Timer mode 1: PWM mode	R/W
b5	PWMC1	PWM mode of TRDIOC1 select bit		R/W
b6	PWMD1	PWM mode of TRDIOD1 select bit		R/W
b7	—	Nothing is assigned. If necessary, set to 0. When read, the content is 1.		—

20.5.6 Timer RD Function Control Register (TRDFCR) in PWM Mode

Address 013Ah

Bit	b7	b6	b5	b4	b3	b2	b1	b0
Symbol	PWM3	STCLK	ADEG	ADTRG	OLS1	OLS0	CMD1	CMD0
After Reset	1	0	0	0	0	0	0	0

Bit	Symbol	Bit Name	Function	R/W	
b0	CMD0	Combination mode select bit ⁽¹⁾	Set to 00b (timer mode, PWM mode, or PWM3 mode) in PWM mode.	R/W	
b1	CMD1			R/W	
b2	OLS0	Normal-phase output level select bit (in reset synchronous PWM mode or complementary PWM mode)	This bit is disabled in PWM mode.	R/W	
b3	OLS1			R/W	
b4	ADTRG			A/D trigger enable bit (in complementary PWM mode)	R/W
b5	ADEG			A/D trigger edge select bit (in complementary PWM mode)	R/W
b6	STCLK	External clock input select bit	0: External clock input disabled 1: External clock input enabled	R/W	
b7	PWM3	PWM3 mode select bit ⁽²⁾	Set this bit to 1 (other than PWM3 mode) in PWM mode.	R/W	

Notes:

- Set bits CMD1 to CMD0 when both the TSTART0 and TSTART1 bits in the TRDSTR register are set to 0 (count stops).
- When bits CMD1 to CMD0 are set to 00b (timer mode, PWM mode, or PWM3 mode), the setting of the PWM3 bit is enabled.

20.5.7 Timer RD Output Master Enable Register 1 (TRDOER1) in PWM Mode

Address 013Bh

Bit	b7	b6	b5	b4	b3	b2	b1	b0
Symbol	ED1	EC1	EB1	EA1	ED0	EC0	EB0	EA0
After Reset	1	1	1	1	1	1	1	1

Bit	Symbol	Bit Name	Function	R/W
b0	EA0	TRDIOA0 output disable bit	Set this bit to 1 (the TRDIOA0 pin is used as a programmable I/O port) in PWM mode.	R/W
b1	EB0	TRDIOB0 output disable bit	0: Enable output 1: Disable output (The TRDIOB0 pin is used as a programmable I/O port.)	R/W
b2	EC0	TRDIOC0 output disable bit	0: Enable output 1: Disable output (The TRDIOC0 pin is used as a programmable I/O port.)	R/W
b3	ED0	TRDIOD0 output disable bit	0: Enable output 1: Disable output (The TRDIOD0 pin is used as a programmable I/O port.)	R/W
b4	EA1	TRDIOA1 output disable bit	Set this bit to 1 (the TRDIOA1 pin is used as a programmable I/O port) in PWM mode.	R/W
b5	EB1	TRDIOB1 output disable bit	0: Enable output 1: Disable output (The TRDIOB1 pin is used as a programmable I/O port.)	R/W
b6	EC1	TRDIOC1 output disable bit	0: Enable output 1: Disable output (The TRDIOC1 pin is used as a programmable I/O port.)	R/W
b7	ED1	TRDIOD1 output disable bit	0: Enable output 1: Disable output (The TRDIOD1 pin is used as a programmable I/O port.)	R/W

20.5.8 Timer RD Output Master Enable Register 2 (TRDOER2) in PWM Mode

Address 013Ch

Bit	b7	b6	b5	b4	b3	b2	b1	b0
Symbol	PTO	—	—	—	—	—	—	—
After Reset	0	1	1	1	1	1	1	1

Bit	Symbol	Bit Name	Function	R/W
b0	—	Nothing is assigned. If necessary, set to 0. When read, the content is 1.		—
b1	—			
b2	—			
b3	—			
b4	—			
b5	—			
b6	—			
b7	PTO	INT0 of pulse output forced cutoff signal input enabled bit ⁽¹⁾	0: Pulse output forced cutoff input disabled 1: Pulse output forced cutoff input enabled (All bits in the TRDOER1 register are set to 1 (disable output) when "L" is applied to the INT0 pin.)	R/W

Note:

1. Refer to **20.2.4 Pulse Output Forced Cutoff**.

20.5.9 Timer RD Output Control Register (TRDOCR) in PWM Mode

Address 013Dh

Bit	b7	b6	b5	b4	b3	b2	b1	b0
Symbol	TOD1	TOC1	TOB1	TOA1	TOD0	TOC0	TOB0	TOA0
After Reset	0	0	0	0	0	0	0	0

Bit	Symbol	Bit Name	Function	R/W
b0	TOA0	TRDIOA0 output level select bit	Set this bit to 0 (enable output) in PWM mode.	R/W
b1	TOB0	TRDIOB0 output level select bit ⁽¹⁾	0: Initial output is inactive level 1: Initial output is active level	R/W
b2	TOC0	TRDIOC0 initial output level select bit ⁽¹⁾		R/W
b3	TOD0	TRDIOD0 initial output level select bit ⁽¹⁾		R/W
b4	TOA1	TRDIOA1 initial output level select bit	Set this bit to 0 (enable output) in PWM mode.	R/W
b5	TOB1	TRDIOB1 initial output level select bit ⁽¹⁾	0: Inactive level 1: Active level	R/W
b6	TOC1	TRDIOC1 initial output level select bit ⁽¹⁾		R/W
b7	TOD1	TRDIOD1 initial output level select bit ⁽¹⁾		R/W

Note:

1. If the pin function is set for waveform output (refer to **7.5 Port Settings**), the initial output level is output when the TRDOCR register is set.

Write to the TRDOCR register when both the TSTART0 and TSTART1 bits in the TRDSTR register are set to 0 (count stops).

20.5.10 Timer RD Control Register i (TRDCRi) (i = 0 or 1) in PWM Mode

Address 0140h (TRDCR0), 0150h (TRDCR1)

Bit	b7	b6	b5	b4	b3	b2	b1	b0
Symbol	CCLR2	CCLR1	CCLR0	CKEG1	CKEG0	TCK2	TCK1	TCK0
After Reset	0	0	0	0	0	0	0	0

Bit	Symbol	Bit Name	Function	R/W
b0	TCK0	Count source select bit	b2 b1 b0 0 0 0: f1 0 0 1: f2 0 1 0: f4 0 1 1: f8 1 0 0: f32 1 0 1: TRDCLK input ⁽¹⁾ 1 1 0: fOCO40M 1 1 1: fOCO-F ⁽³⁾	R/W
b1	TCK1			R/W
b2	TCK2			R/W
b3	CKEG0	External clock edge select bit ⁽²⁾	b4 b3 0 0: Count at the rising edge 0 1: Count at the falling edge 1 0: Count at both edges 1 1: Do not set.	R/W
b4	CKEG1			R/W
b5	CCLR0	TRDi counter clear select bit	Set to 001b (the TRDi register cleared at compare match with TRDGRAi register) in PWM mode.	R/W
b6	CCLR1			R/W
b7	CCLR2			R/W

Notes:

1. Enabled when the STCLK bit in the TRDFCR register is 1 (external clock input enabled).
2. Enabled when bits TCK2 to TCK0 are set to 101b (TRDCLK input) and the STCLK bit in the TRDFCR register is set to 1 (external clock input enabled).
3. To select fOCO-F, set it to the clock frequency higher than the CPU clock frequency.

20.5.11 Timer RD Status Register i (TRDSRi) (i = 0 or 1) in PWM Mode

Address 0143h (TRDSR0), 0153h (TRDSR1)

Bit	b7	b6	b5	b4	b3	b2	b1	b0	
Symbol	—	—	UDF	OVF	IMFD	IMFC	IMFB	IMFA	
After Reset	1	1	1	0	0	0	0	0	TRDSR0 register
After Reset	1	1	0	0	0	0	0	0	TRDSR1 register

Bit	Symbol	Bit Name	Function	R/W
b0	IMFA	Input capture / compare match flag A	[Source for setting this bit to 0] Write 0 after read ⁽²⁾ [Source for setting this bit to 1] When the value in the TRDi register matches with the value in the TRDGRAi register.	R/W
b1	IMFB	Input capture / compare match flag B	[Source for setting this bit to 0] Write 0 after read ⁽²⁾ [Source for setting this bit to 1] When the value in the TRDi register matches with the value in the TRDGRBi register.	R/W
b2	IMFC	Input capture / compare match flag C	[Source for setting this bit to 0] Write 0 after read ⁽²⁾ [Source for setting this bit to 1] When the value in the TRDi register matches with the value in the TRDGRCi register ⁽³⁾ .	R/W
b3	IMFD	Input capture / compare match flag D	[Source for setting this bit to 0] Write 0 after read ⁽²⁾ [Source for setting this bit to 1] When the value in the TRDi register matches with the value in the TRDGRDi register ⁽³⁾ .	R/W
b4	OVF	Overflow flag	[Source for setting this bit to 0] Write 0 after read ⁽²⁾ [Source for setting this bit to 1] When the TRDi register overflows.	R/W
b5	UDF	Underflow flag ⁽¹⁾	This bit is disabled in PWM Mode.	R/W
b6	—	Nothing is assigned. If necessary, set to 0. When read, the content is 1.		—
b7	—			—

Notes:

- Nothing is assigned to b5 in the TRDSR0 register. When writing to b5, write 0. When reading, the content is 1.
- The writing results are as follows:
 - This bit is set to 0 when the read result is 1 and 0 is written to the same bit.
 - This bit remains unchanged even if the read result is 0 and 0 is written to the same bit. (This bit remains 1 even if it is set to 1 from 0 after reading, and writing 0.)
 - This bit remains unchanged if 1 is written to it.
- Including when the BFji bit in the TRDMR register is set to 1 (TRDGRji is used as the buffer register).

20.5.12 Timer RD Interrupt Enable Register i (TRDIERi) (i = 0 or 1) in PWM Mode

Address 0144h (TRDIER0), 0154h (TRDIER1)

Bit	b7	b6	b5	b4	b3	b2	b1	b0
Symbol	—	—	—	OVIE	IMIED	IMIEC	IMIEB	IMIEA
After Reset	1	1	1	0	0	0	0	0

Bit	Symbol	Bit Name	Function	R/W
b0	IMIEA	Input capture/compare match interrupt enable bit A	0: Disable interrupt (IMIA) by the IMFA bit 1: Enable interrupt (IMIA) by the IMFA bit	R/W
b1	IMIEB	Input capture/compare match interrupt enable bit B	0: Disable interrupt (IMIB) by the IMFB bit 1: Enable interrupt (IMIB) by the IMFB bit	R/W
b2	IMIEC	Input capture/compare match interrupt enable bit C	0: Disable interrupt (IMIC) by the IMFC bit 1: Enable interrupt (IMIC) by the IMFC bit	R/W
b3	IMIED	Input capture/compare match interrupt enable bit D	0: Disable interrupt (IMID) by the IMFD bit 1: Enable interrupt (IMID) by the IMFD bit	R/W
b4	OVIE	Overflow/underflow interrupt enable bit	0: Disable interrupt (OVI) by the OVF bit 1: Enable interrupt (OVI) by the OVF bit	R/W
b5	—	Nothing is assigned. If necessary, set to 0. When read, the content is 1.		—
b6	—			
b7	—			

20.5.13 Timer RD PWM Mode Output Level Control Register i (TRDPOCRi) (i = 0 or 1) in PWM Mode

Address 0145h (TRDPOCR0), 0155h (TRDPOCR1)

Bit	b7	b6	b5	b4	b3	b2	b1	b0
Symbol	—	—	—	—	—	POLD	POLC	POLB
After Reset	1	1	1	1	1	0	0	0

Bit	Symbol	Bit Name	Function	R/W
b0	POLB	PWM mode output level control bit B	0: "L" active TRDIOBi output level is selected 1: "H" active TRDIOBi output level is selected	R/W
b1	POLC	PWM mode output level control bit C	0: "L" active TRDIOCi output level is selected 1: "H" active TRDIOCi output level is selected	R/W
b2	POLD	PWM mode output level control bit D	0: "L" active TRDIODi output level is selected 1: "H" active TRDIODi output level is selected	R/W
b3	—	Nothing is assigned. If necessary, set to 0. When read, the content is 1.		—
b4	—			
b5	—			
b6	—			
b7	—			

20.5.14 Timer RD Counter i (TRDi) (i = 0 or 1) in PWM Mode

Address 0147h to 0146h (TRD0), 0157h to 0156h (TRD1)

Bit	b7	b6	b5	b4	b3	b2	b1	b0
Symbol	—	—	—	—	—	—	—	—
After Reset	0	0	0	0	0	0	0	0

Bit	b15	b14	b13	b12	b11	b10	b9	b8
Symbol	—	—	—	—	—	—	—	—
After Reset	0	0	0	0	0	0	0	0

Bit	Function	Setting Range	R/W
b15 to b0	Count the count source. Count operation is incremented. When an overflow occurs, the OVF bit in the TRDSRi register is set to 1.	0000h to FFFFh	R/W

Access the TRDi register in 16-bit units. Do not access it in 8-bit units.

20.5.15 Timer RD General Registers Ai, Bi, Ci, and Di (TRDGRAi, TRDGRBi, TRDGRCi, TRDGRDi) (i = 0 or 1) in PWM Mode

Address 0149h to 0148h (TRDGRA0), 014Bh to 014Ah (TRDGRB0),
014Dh to 014Ch (TRDGRC0), 014Fh to 014Eh (TRDGRD0),
0159h to 0158h (TRDGRA1), 015Bh to 015Ah (TRDGRB1),
015Dh to 015Ch (TRDGRC1), 015Fh to 015Eh (TRDGRD1)

Bit	b7	b6	b5	b4	b3	b2	b1	b0
Symbol	—	—	—	—	—	—	—	—
After Reset	1	1	1	1	1	1	1	1

Bit	b15	b14	b13	b12	b11	b10	b9	b8
Symbol	—	—	—	—	—	—	—	—
After Reset	1	1	1	1	1	1	1	1

Bit	Function	R/W
b15 to b0	Refer to Table 20.10 TRDGRji Register Functions in PWM Mode	R/W

Access registers TRDGRAi to TRDGRDi in 16-bit units. Do not access them in 8-bit units.

The following registers are disabled in the PWM mode: TRDDF0, TRDDF1, TRDIORA0, TRDIORC0, TRDIORA1, and TRDIORC1.

Table 20.10 TRDGRji Register Functions in PWM Mode

Register	Setting	Register Function	PWM Output Pin
TRDGRAi	—	General register. Set the PWM period	—
TRDGRBi	—	General register. Set the changing point of PWM output	TRDIOBi
TRDGRCi	BFCi = 0	General register. Set the changing point of PWM output	TRDIOCi
TRDGRDi	BFDi = 0		TRDIODi
TRDGRCi	BFCi = 1	Buffer register. Set the next PWM period (Refer to 20.2.2 Buffer Operation.)	—
TRDGRDi	BFDi = 1	Buffer register. Set the changing point of the next PWM output (Refer to 20.2.2 Buffer Operation.)	TRDIOBi

i = 0 or 1

BFCi, BFDi: Bits in TRDMR register

20.5.16 Timer RD Pin Select Register 0 (TRDPSR0)

Address 0184h

Bit	b7	b6	b5	b4	b3	b2	b1	b0
Symbol	—	TRDIOD0SELO	—	TRDIOC0SELO	—	TRDIOB0SELO	—	TRDIOA0SELO
After Reset	0	0	0	0	0	0	0	0

Bit	Symbol	Bit Name	Function	R/W
b0	TRDIOA0SELO	TRDIOA0/TRDCLK pin select bit	0: TRDIOA0/TRDCLK pin not used 1: P3_5 assigned	R/W
b1	—	Nothing is assigned. If necessary, set to 0. When read, the content is 0.		—
b2	TRDIOB0SELO	TRDIOB0 pin select bit	0: TRDIOB0 pin not used 1: P3_4 assigned	R/W
b3	—	Reserved bit	Set to 0.	R/W
b4	TRDIOC0SELO	TRDIOC0 pin select bit	0: TRDIOC0 pin not used 1: P3_7 assigned	R/W
b5	—	Reserved bit	Set to 0.	R/W
b6	TRDIOD0SELO	TRDIOD0 pin select bit	0: TRDIOD0 pin not used 1: P3_3 assigned	R/W
b7	—	Nothing is assigned. If necessary, set to 0. When read, the content is 0.		—

The TRDPSR0 register selects which pin is assigned to the timer RD I/O. To use the I/O pin for timer RD, set this register.

Set the TRDPSR0 register before setting the timer RD associated registers. Also, do not change the setting value in this register during timer RD operation.

20.5.17 Timer RD Pin Select Register 1 (TRDPSR1)

Address 0185h

Bit	b7	b6	b5	b4	b3	b2	b1	b0
Symbol	—	TRDIOD1SELO	—	TRDIOC1SELO	—	TRDIOB1SELO	—	TRDIOA1SELO
After Reset	0	0	0	0	0	0	0	0

Bit	Symbol	Bit Name	Function	R/W
b0	TRDIOA1SELO	TRDIOA1 pin select bit	0: TRDIOA1 pin not used 1: P1_0 assigned	R/W
b1	—	Nothing is assigned. If necessary, set to 0. When read, the content is 0.		—
b2	TRDIOB1SELO	TRDIOB1 pin select bit	0: TRDIOB1 pin not used 1: P1_1 assigned	R/W
b3	—	Nothing is assigned. If necessary, set to 0. When read, the content is 0.		—
b4	TRDIOC1SELO	TRDIOC1 pin select bit	0: TRDIOC1 pin not used 1: P1_2 assigned	R/W
b5	—	Reserved bit	Set to 0.	R/W
b6	TRDIOD1SELO	TRDIOD1 pin select bit	0: TRDIOD1 pin not used 1: P1_3 assigned	R/W
b7	—	Reserved bit	Set to 0.	R/W

The TRDPSR1 register selects which pin is assigned to the timer RD I/O. To use the I/O pin for timer RD, set this register.

Set the TRDPSR1 register before setting the timer RD associated registers. Also, do not change the setting value in this register during timer RD operation.

20.5.18 Operating Example

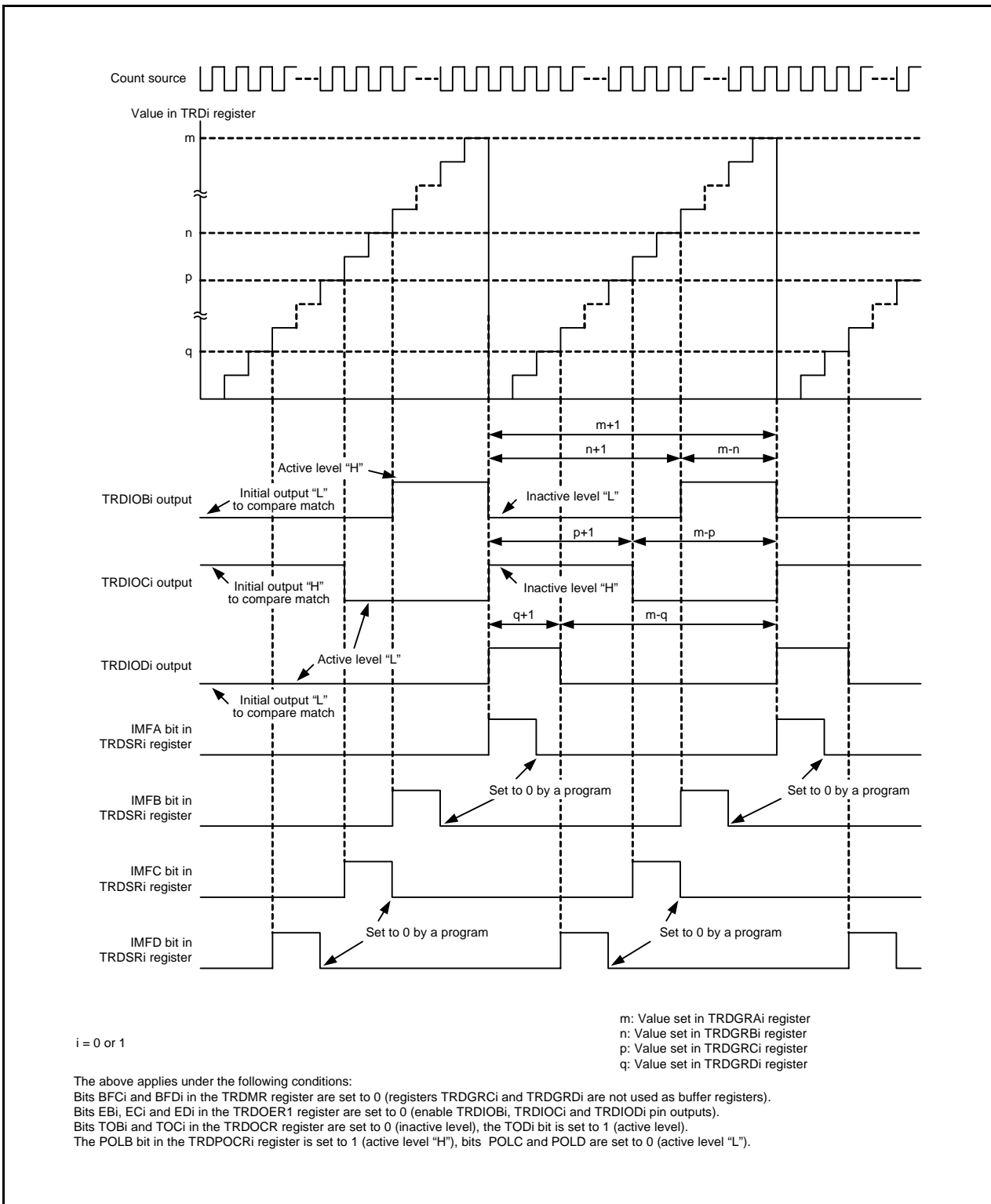

Figure 20.15 Operating Example of PWM Mode

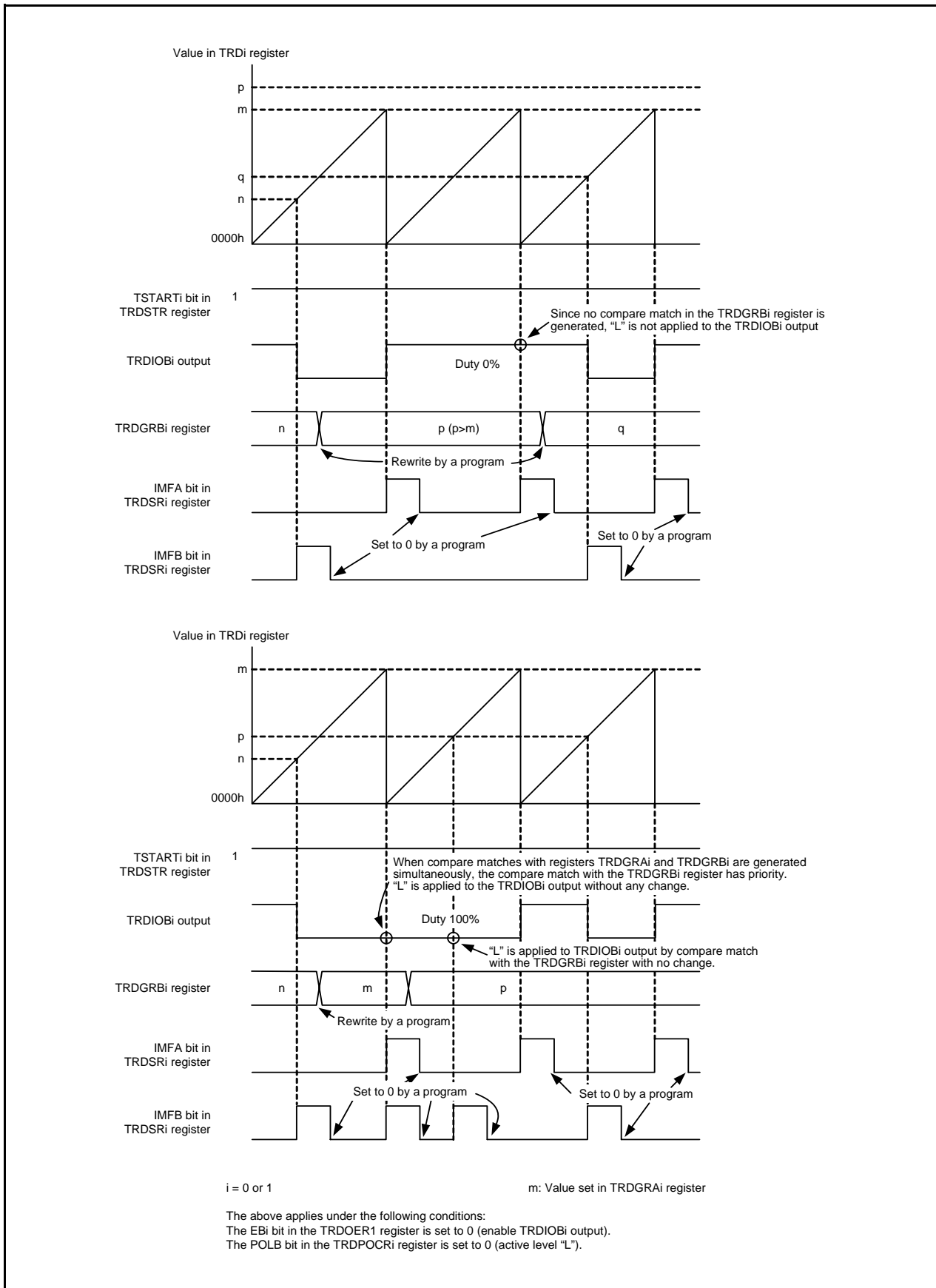

Figure 20.16 Operating Example of PWM Mode (Duty 0%, Duty 100%)

20.5.19 A/D Trigger Generation

A compare match signal with registers TRDi (i = 0 or 1) and TRDGRji (j = A, B, C, or D) can be used as the conversion start trigger of the A/D converter.

The TRDADCR register is used to select which compare match is used.

20.6 Reset Synchronous PWM Mode

In this mode, 3 normal-phases and 3 counter-phases of the PWM waveform are output with the same period (three-phase, sawtooth wave modulation, and no dead time).

Figure 20.17 shows a Block Diagram of Reset Synchronous PWM Mode, and Table 20.11 lists the Reset Synchronous PWM Mode Specifications. Figure 20.18 shows an Operating Example of Reset Synchronous PWM Mode.

Refer to **Figure 20.16 Operating Example of PWM Mode (Duty 0%, Duty 100%)** for an operating example of PWM Mode with duty 0% and duty 100%.

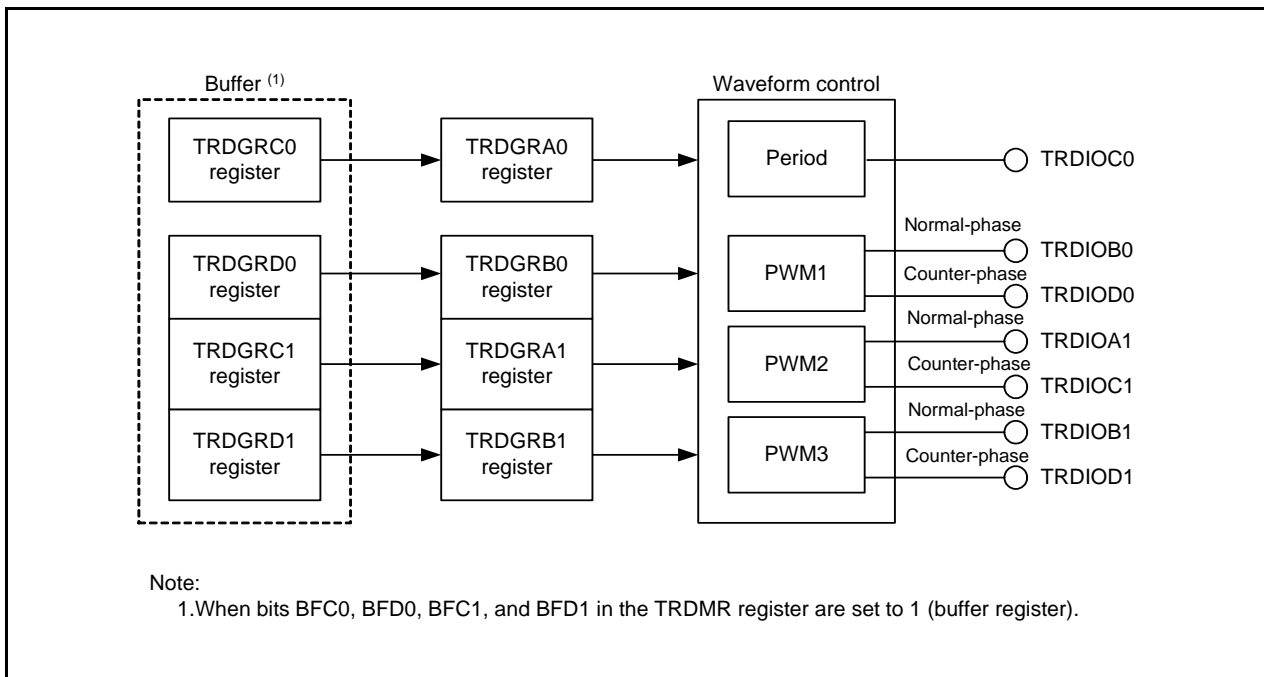
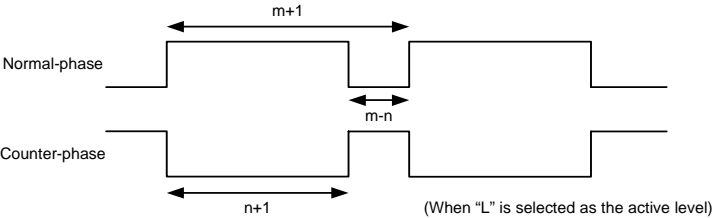

Figure 20.17 Block Diagram of Reset Synchronous PWM Mode

Table 20.11 Reset Synchronous PWM Mode Specifications

Item	Specification
Count sources	f1, f2, f4, f8, f32, fOCO40M, fOCO-F External signal input to the TRDCLK pin (valid edge selected by a program)
Count operations	The TRD0 register is incremented (the TRD1 register is not used).
PWM waveform	<p>PWM period : $1/f_k \times (m+1)$ Active level width of normal-phase : $1/f_k \times (m-n)$ Active level width of counter-phase: $1/f_k \times (n+1)$ f_k: Frequency of count source m: Value set in the TRDGRA0 register n: Value set in the TRDGRB0 register (PWM1 output), Value set in the TRDGRA1 register (PWM2 output), Value set in the TRDGRB1 register (PWM3 output)</p>  <p>(When "L" is selected as the active level)</p>
Count start condition	1 (count starts) is written to the TSTART0 bit in the TRDSTR register.
Count stop conditions	<ul style="list-style-type: none"> • 0 (count stops) is written to the TSTART0 bit when the CSEL0 bit in the TRDSTR register is set to 1. (The PWM output pin outputs the initial output level selected by bits OLS0 and OLS1 in the TRDFCR register.) • When the CSEL0 bit in the TRDSTR register is set to 0, the count stops at the compare match in the TRDGRA0 register. (The PWM output pin outputs the initial output level selected by bits OLS0 and OLS1 in the TRDFCR register.)
Interrupt request generation timing	<ul style="list-style-type: none"> • Compare match (The content of the TRD0 register matches content of registers TRDGRj0, TRDGRA1, and TRDGRB1) • The TRD0 register overflows
TRDIOA0 pin function	Programmable I/O port or TRDCLK (external clock) input
TRDIOB0 pin function	PWM1 output normal-phase output
TRDIOD0 pin function	PWM1 output counter-phase output
TRDIOA1 pin function	PWM2 output normal-phase output
TRDIOC1 pin function	PWM2 output counter-phase output
TRDIOB1 pin function	PWM3 output normal-phase output
TRDIOD1 pin function	PWM3 output counter-phase output
TRDIOC0 pin function	Output inverted every PWM period
INT0 pin function	Programmable I/O port, pulse output forced cutoff signal input, or INT0 interrupt input
Read from timer	The count value can be read by reading the TRD0 register.
Write to timer	The value can be written to the TRD0 register.
Selectable functions	<ul style="list-style-type: none"> • The normal-phase and counter-phase active level and initial output level are selected individually. • Buffer operation (Refer to 20.2.2 Buffer Operation.) • Pulse output forced cutoff signal input (Refer to 20.2.4 Pulse Output Forced Cutoff.) • A/D trigger generation

j = A, B, C, or D

20.6.1 Module Standby Control Register (MSTCR)

Address 0008h

Bit	b7	b6	b5	b4	b3	b2	b1	b0
Symbol	—	—	MSTTRC	MSTTRD	MSTIIC	—	—	—
After Reset	0	0	0	0	0	0	0	0

Bit	Symbol	Bit Name	Function	R/W
b0	—	Nothing is assigned. If necessary, set to 0. When read, the content is 0.		—
b1	—			
b2	—			
b3	MSTIIC	SSU standby bit	0: Active 1: Standby ⁽¹⁾	R/W
b4	MSTTRD	Timer RD standby bit	0: Active 1: Standby ^(2, 3)	R/W
b5	MSTTRC	Timer RC standby bit	0: Active 1: Standby ⁽⁴⁾	R/W
b6	—	Reserved bit	Set to 0.	R/W
b7	—	Nothing is assigned. If necessary, set to 0. When read, the content is 0.		—

Notes:

1. Stop the SSU and the I²C bus functions before setting to standby. When the MSTIIC bit is set to 1 (standby), any access to the SSU associated registers (addresses 0193h to 019Dh) is disabled.
2. Stop the timer RD function before setting to standby. When the MSTTRD bit is set to 1 (standby), any access to the timer RD associated registers (addresses 0135h to 015Fh) is disabled.
3. To set the MSTTRD bit to 1 (standby), set bits TCK2 to TCK0 in the TRDCR_i (i = 0 or 1) register to 000b (f1).
4. Stop the timer RC function before setting to standby. When the MSTTRC bit is set to 1 (standby), any access to the timer RC associated registers (addresses 0120h to 0133h) is disabled.

20.6.2 Timer RD Trigger Control Register (TRDADCR)

Address 0136h

Bit	b7	b6	b5	b4	b3	b2	b1	b0
Symbol	ADTRGD1E	ADTRGC1E	ADTRGB1E	ADTRGA1E	ADTRGD0E	ADTRGC0E	ADTRGB0E	ADTRGA0E
After Reset	0	0	0	0	0	0	0	0

Bit	Symbol	Bit Name	Function	R/W
b0	ADTRGA0E	A/D trigger A0 enable bit	0: A/D trigger disabled 1: A/D trigger generated at compare match with registers TRD0 and TRDGRA0	R/W
b1	ADTRGB0E	A/D trigger B0 enable bit	0: A/D trigger disabled 1: A/D trigger generated at compare match with registers TRD0 and TRDGRB0	R/W
b2	ADTRGC0E	A/D trigger C0 enable bit	0: A/D trigger disabled 1: A/D trigger generated at compare match with registers TRD0 and TRDGRC0	R/W
b3	ADTRGD0E	A/D trigger D0 enable bit	0: A/D trigger disabled 1: A/D trigger generated at compare match with registers TRD0 and TRDGRD0	R/W
b4	ADTRGA1E	A/D trigger A1 enable bit	0: A/D trigger disabled 1: A/D trigger generated at compare match with registers TRD1 and TRDGRA1	R/W
b5	ADTRGB1E	A/D trigger B1 enable bit	0: A/D trigger disabled 1: A/D trigger generated at compare match with registers TRD1 and TRDGRB1	R/W
b6	ADTRGC1E	A/D trigger C1 enable bit	0: A/D trigger disabled 1: A/D trigger generated at compare match with registers TRD1 and TRDGRC1	R/W
b7	ADTRGD1E	A/D trigger D1 enable bit	0: A/D trigger disabled 1: A/D trigger generated at compare match with registers TRD1 and TRDGRD1	R/W

20.6.3 Timer RD Start Register (TRDSTR) in Reset Synchronous PWM Mode

Address 0137h

Bit	b7	b6	b5	b4	b3	b2	b1	b0
Symbol	—	—	—	—	CSEL1	CSEL0	TSTART1	TSTART0
After Reset	1	1	1	1	1	1	0	0

Bit	Symbol	Bit Name	Function	R/W
b0	TSTART0	TRD0 count start flag ⁽³⁾	0: Count stops ⁽¹⁾ 1: Count starts	R/W
b1	TSTART1	TRD1 count start flag ⁽⁴⁾	0: Count stops ⁽²⁾ 1: Count starts	R/W
b2	CSEL0	TRD0 count operation select bit	0: Count stops at the compare match with the TRDGRA0 register 1: Count continues after the compare match with the TRDGRA0 register	R/W
b3	CSEL1	TRD1 count operation select bit	0: Count stops at the compare match with the TRDGRA1 register 1: Count continues after the compare match with the TRDGRA1 register	R/W
b4	—	Nothing is assigned. If necessary, set to 0. When read, the content is 1.		—
b5	—			
b6	—			
b7	—			

Notes:

- When the CSEL0 bit is set to 1, write 0 to the TSTART0 bit.
- When the CSEL1 bit is set to 1, write 0 to the TSTART1 bit.
- When the CSEL0 bit is set to 0 and the compare match signal (TRDIOA0) is generated, this bit is set to 0 (count stops).
- When the CSEL1 bit is set to 0 and the compare match signal (TRDIOA1) is generated, this bit is set to 0 (count stops).

Set the TRDSTR register using the MOV instruction (do not use the bit handling instruction). Refer to **20.10.1 TRDSTR Register** of **Notes on Timer RD**.

20.6.4 Timer RD Mode Register (TRDMR) in Reset Synchronous PWM Mode

Address 0138h

Bit	b7	b6	b5	b4	b3	b2	b1	b0
Symbol	BFD1	BFC1	BFD0	BFC0	—	—	—	SYNC
After Reset	0	0	0	0	1	1	1	0

Bit	Symbol	Bit Name	Function	R/W
b0	SYNC	Timer RD synchronous bit	Set this bit to 0 (registers TRD and TRD1 operate independently) in reset synchronous PWM mode.	R/W
b1	—	Nothing is assigned. If necessary, set to 0. When read, the content is 1.		—
b2	—			
b3	—			
b4	BFC0	TRDGRC0 register function select bit	0: General register 1: Buffer register of TRDGRA0 register	R/W
b5	BFD0	TRDGRD0 register function select bit	0: General register 1: Buffer register of TRDGRB0 register	R/W
b6	BFC1	TRDGRC1 register function select bit	0: General register 1: Buffer register of TRDGRA1 register	R/W
b7	BFD1	TRDGRD1 register function select bit	0: General register 1: Buffer register of TRDGRB1 register	R/W

20.6.5 Timer RD Function Control Register (TRDFCR) in Reset Synchronous PWM Mode

Address 013Ah

Bit	b7	b6	b5	b4	b3	b2	b1	b0
Symbol	PWM3	STCLK	ADEG	ADTRG	OLS1	OLS0	CMD1	CMD0
After Reset	1	0	0	0	0	0	0	0

Bit	Symbol	Bit Name	Function	R/W
b0	CMD0	Combination mode select bit ⁽¹⁾	Set to 01b (reset synchronous PWM mode) in reset synchronous PWM mode.	R/W
b1	CMD1			R/W
b2	OLS0	Normal-phase output level select bit (in reset synchronous PWM mode or complementary PWM mode)	0: Initial output "H", Active level "L" 1: Initial output "L", Active level "H"	R/W
b3	OLS1	Counter-phase output level select bit (in reset synchronous PWM mode or complementary PWM mode)		R/W
b4	ADTRG	A/D trigger enable bit (in complementary PWM mode)	This bit is disabled in reset synchronous PWM mode.	R/W
b5	ADEG	A/D trigger edge select bit (in complementary PWM mode)		R/W
b6	STCLK	External clock input select bit	0: External clock input disabled 1: External clock input enabled	R/W
b7	PWM3	PWM3 mode select bit ⁽²⁾	This bit is disabled in reset synchronous PWM mode.	R/W

Notes:

1. Set bits CMD1 to CMD0 when both the TSTART0 and TSTART1 bits are set to 0 (count stops).
2. When bits CMD1 to CMD0 are set to 00b (timer mode, PWM mode, or PWM3 mode), the setting of the PWM3 bit is enabled.

20.6.6 Timer RD Output Master Enable Register 1 (TRDOER1) in Reset Synchronous PWM Mode

Address 013Bh

Bit	b7	b6	b5	b4	b3	b2	b1	b0
Symbol	ED1	EC1	EB1	EA1	ED0	EC0	EB0	EA0
After Reset	1	1	1	1	1	1	1	1

Bit	Symbol	Bit Name	Function	R/W
b0	EA0	TRDIOA0 output disable bit	Set this bit to 1 (the TRDIOA0 pin is used as a programmable I/O port) in reset synchronous PWM mode.	R/W
b1	EB0	TRDIOB0 output disable bit	0: Enable output 1: Disable output (The TRDIOB0 pin is used as a programmable I/O port.)	R/W
b2	EC0	TRDIOC0 output disable bit	0: Enable output 1: Disable output (The TRDIOC0 pin is used as a programmable I/O port.)	R/W
b3	ED0	TRDIOD0 output disable bit	0: Enable output 1: Disable output (The TRDIOD0 pin is used as a programmable I/O port.)	R/W
b4	EA1	TRDIOA1 output disable bit	0: Enable output 1: Disable output (The TRDIOA1 pin is used as a programmable I/O port.)	R/W
b5	EB1	TRDIOB1 output disable bit	0: Enable output 1: Disable output (The TRDIOB1 pin is used as a programmable I/O port.)	R/W
b6	EC1	TRDIOC1 output disable bit	0: Enable output 1: Disable output (The TRDIOC1 pin is used as a programmable I/O port.)	R/W
b7	ED1	TRDIOD1 output disable bit	0: Enable output 1: Disable output (The TRDIOD1 pin is used as a programmable I/O port.)	R/W

20.6.7 Timer RD Output Master Enable Register 2 (TRDOER2) in Reset Synchronous PWM Mode

Address 013Ch

Bit	b7	b6	b5	b4	b3	b2	b1	b0
Symbol	PTO	—	—	—	—	—	—	—
After Reset	0	1	1	1	1	1	1	1

Bit	Symbol	Bit Name	Function	R/W
b0	—	Nothing is assigned. If necessary, set to 0. When read, the content is 1.		—
b1	—			
b2	—			
b3	—			
b4	—			
b5	—			
b6	—			
b7	PTO	$\overline{\text{INT0}}$ of pulse output forced cutoff signal input enabled bit ⁽¹⁾	0: Pulse output forced cutoff input disabled 1: Pulse output forced cutoff input enabled (All bits in the TRDOER1 register are set to <u>1</u> (disable output) when "L" is applied to the $\overline{\text{INT0}}$ pin.)	R/W

Note:

1. Refer to **20.2.4 Pulse Output Forced Cutoff**.

20.6.8 Timer RD Control Register 0 (TRDCR0) in Reset Synchronous PWM Mode

Address 0140h

Bit	b7	b6	b5	b4	b3	b2	b1	b0
Symbol	CCLR2	CCLR1	CCLR0	CKEG1	CKEG0	TCK2	TCK1	TCK0
After Reset	0	0	0	0	0	0	0	0

Bit	Symbol	Bit Name	Function	R/W
b0	TCK0	Count source select bit	b2 b1 b0 0 0 0: f1 0 0 1: f2 0 1 0: f4 0 1 1: f8 1 0 0: f32 1 0 1: TRDCLK input (1) 1 1 0: fOCO40M 1 1 1: fOCO-F (3)	R/W
b1	TCK1			R/W
b2	TCK2			R/W
b3	CKEG0			External clock edge select bit (2)
b4	CKEG1	R/W		
b5	CCLR0	TRD0 counter clear select bit	Set to 001b (TRD0 register cleared at compare match with TRDGRA0 register) in reset synchronous PWM mode.	R/W
b6	CCLR1			R/W
b7	CCLR2			R/W

Notes:

1. Enabled when the ITCLKi bit in the STCLK bit in the TRDFCR register is 1 (external clock input enabled).
2. Enabled when bits TCK2 to TCK0 are set to 101b (TRDCLK input) and the STCLK bit in the TRDFCR register is set to 1 (external clock input enabled).
3. To select fOCO-F, set it to the clock frequency higher than the CPU clock frequency.

The TRDCR1 register is not used in reset synchronous PWM mode.

20.6.9 Timer RD Status Register i (TRDSRi) (i = 0 or 1) in Reset Synchronous PWM Mode

Address 0143h (TRDSR0), 0153h (TRDSR1)

Bit	b7	b6	b5	b4	b3	b2	b1	b0	
Symbol	—	—	UDF	OVF	IMFD	IMFC	IMFB	IMFA	
After Reset	1	1	1	0	0	0	0	0	TRDSR0 register
After Reset	1	1	0	0	0	0	0	0	TRDSR1 register

Bit	Symbol	Bit Name	Function	R/W
b0	IMFA	Input capture / compare match flag A	[Source for setting this bit to 0] Write 0 after read (2). [Source for setting this bit to 1] When the value in the TRDi register matches with the value in the TRDGRAi register.	R/W
b1	IMFB	Input capture / compare match flag B	[Source for setting this bit to 0] Write 0 after read (2). [Source for setting this bit to 1] When the value in the TRDi register matches with the value in the TRDGRBi register.	R/W
b2	IMFC	Input capture / compare match flag C	[Source for setting this bit to 0] Write 0 after read (2). [Source for setting this bit to 1] When the value in the TRDi register matches with the value in the TRDGRCi register (3).	R/W
b3	IMFD	Input capture / compare match flag D	[Source for setting this bit to 0] Write 0 after read (2). [Source for setting this bit to 1] When the value in the TRDi register matches with the value in the TRDGRDi register (3).	R/W
b4	OVF	Overflow flag	[Source for setting this bit to 0] Write 0 after read (2). [Source for setting this bit to 1] When the TRDi register overflows.	R/W
b5	UDF	Underflow flag (1)	This bit is disabled in reset synchronous PWM mode.	R/W
b6	—	Nothing is assigned. If necessary, set to 0. When read, the content is 1.		—
b7	—			

Notes:

- Nothing is assigned to b5 in the TRDSR0 register. When writing to b5, write 0. When reading, the content is 1.
- The writing results are as follows:
 - This bit is set to 0 when the read result is 1 and 0 is written to the same bit.
 - This bit remains unchanged even if the read result is 0 and 0 is written to the same bit. (This bit remains 1 even if it is set to 1 from 0 after reading, and writing 0.)
 - This bit remains unchanged if 1 is written to it.
- Including when the BFji bit in the TRDMR register is set to 1 (TRDGRji is used as the buffer register).

20.6.10 Timer RD Interrupt Enable Register i (TRDIERi) (i = 0 or 1) in Reset Synchronous PWM Mode

Address 0144h (TRDIER0), 0154h (TRDIER1)

Bit	b7	b6	b5	b4	b3	b2	b1	b0
Symbol	—	—	—	OVIE	IMIED	IMIEC	IMIEB	IMIEA
After Reset	1	1	1	0	0	0	0	0

Bit	Symbol	Bit Name	Function	R/W
b0	IMIEA	Input capture/compare match interrupt enable bit A	0: Disable interrupt (IMIA) by the IMFA bit 1: Enable interrupt (IMIA) by the IMFA bit	R/W
b1	IMIEB	Input capture/compare match interrupt enable bit B	0: Disable interrupt (IMIB) by the IMFB bit 1: Enable interrupt (IMIB) by the IMFB bit	R/W
b2	IMIEC	Input capture/compare match interrupt enable bit C	0: Disable interrupt (IMIC) by the IMFC bit 1: Enable interrupt (IMIC) by the IMFC bit	R/W
b3	IMIED	Input capture/compare match interrupt enable bit D	0: Disable interrupt (IMID) by the IMFD bit 1: Enable interrupt (IMID) by the IMFD bit	R/W
b4	OVIE	Overflow/underflow interrupt enable bit	0: Disable interrupt (OVI) by the OVF or UDF bit 1: Enable interrupt (OVI) by the OVF or UDF bit	R/W
b5	—	Nothing is assigned. If necessary, set to 0. When read, the content is 1.		—
b6	—			
b7	—			

20.6.11 Timer RD Counter 0 (TRD0) in Reset Synchronous PWM Mode

Address 0147h to 0146h

Bit	b7	b6	b5	b4	b3	b2	b1	b0
Symbol	—	—	—	—	—	—	—	—
After Reset	0	0	0	0	0	0	0	0

Bit	b15	b14	b13	b12	b11	b10	b9	b8
Symbol	—	—	—	—	—	—	—	—
After Reset	0	0	0	0	0	0	0	0

Bit	Function	Setting Range	R/W
b15 to b0	Count the count source. Count operation is incremented. When an overflow occurs, the OVF bit in the TRDSR0 register is set to 1.	0000h to FFFFh	R/W

Access the TRD0 register in 16-bit units. Do not access it in 8-bit units.

The TRD1 register is not used in reset synchronous PWM mode.

20.6.12 Timer RD General Registers Ai, Bi, Ci, and Di (TRDGRAi, TRDGRBi, TRDGRCi, TRDGRDi) (i = 0 or 1) in Reset Synchronous PWM Mode

Address 0149h to 0148h (TRDGRA0), 014Bh to 014Ah (TRDGRB0),
014Dh to 014Ch (TRDGRC0), 014Fh to 014Eh (TRDGRD0),
0159h to 0158h (TRDGRA1), 015Bh to 015Ah (TRDGRB1),
015Dh to 015Ch (TRDGRC1), 015Fh to 015Eh (TRDGRD1)

Bit	b7	b6	b5	b4	b3	b2	b1	b0
Symbol	—	—	—	—	—	—	—	—
After Reset	1	1	1	1	1	1	1	1

Bit	b15	b14	b13	b12	b11	b10	b9	b8
Symbol	—	—	—	—	—	—	—	—
After Reset	1	1	1	1	1	1	1	1

Bit	Function	R/W
b15 to b0	Refer to Table 20.12 TRDGRji Register Functions in Reset Synchronous PWM Mode	R/W

Access registers TRDGRAi to TRDGRDi in 16-bit units. Do not access them in 8-bit units.

The following registers are disabled in the reset synchronous PWM mode: TRDPMR, TRDOCR, TRDDF0, TRDDF1, TRDIOA0, TRDIORC0, TRDPOCR0, TRDIOA1, TRDIORC1, and TRDPOCR1.

Table 20.12 TRDGRji Register Functions in Reset Synchronous PWM Mode

Register	Setting	Register Function	PWM Output Pin
TRDGRA0	—	General register. Set the PWM period.	(Output inverted every PWM period and TRDIOC0 pin)
TRDGRB0	—	General register. Set the changing point of PWM1 output.	TRDIOB0 TRDIOD0
TRDGRC0	BFC0 = 0	(These registers are not used in reset synchronous PWM mode.)	—
TRDGRD0	BFD0 = 0		
TRDGRA1	—	General register. Set the changing point of PWM2 output.	TRDIOA1 TRDIOC1
TRDGRB1	—	General register. Set the changing point of PWM3 output.	TRDIOB1 TRDIOD1
TRDGRC1	BFC1 = 0	(These points are not used in reset synchronous PWM mode.)	—
TRDGRD1	BFD1 = 0		
TRDGRC0	BFC0 = 1	Buffer register. Set the next PWM period. (Refer to 20.2.2 Buffer Operation.)	(Output inverted every PWM period and TRDIOC0 pin)
TRDGRD0	BFD0 = 1	Buffer register. Set the changing point of the next PWM1 output. (Refer to 20.2.2 Buffer Operation.)	TRDIOB0 TRDIOD0
TRDGRC1	BFC1 = 1	Buffer register. Set the changing point of the next PWM2 output. (Refer to 20.2.2 Buffer Operation.)	TRDIOA1 TRDIOC1
TRDGRD1	BFD1 = 1	Buffer register. Set the changing point of the next PWM3 output. (Refer to 20.2.2 Buffer Operation.)	TRDIOB1 TRDIOD1

BFC0, BFD0, BFC1, BFD1: Bits in TRDMR register

20.6.13 Timer RD Pin Select Register 0 (TRDPSR0)

Address 0184h

Bit	b7	b6	b5	b4	b3	b2	b1	b0
Symbol	—	TRDIOD0SELO	—	TRDIOC0SELO	—	TRDIOB0SELO	—	TRDIOA0SELO
After Reset	0	0	0	0	0	0	0	0

Bit	Symbol	Bit Name	Function	R/W
b0	TRDIOA0SELO	TRDIOA0/TRDCLK pin select bit	0: TRDIOA0/TRDCLK pin not used 1: P3_5 assigned	R/W
b1	—	Nothing is assigned. If necessary, set to 0. When read, the content is 0.		—
b2	TRDIOB0SELO	TRDIOB0 pin select bit	0: TRDIOB0 pin not used 1: P3_4 assigned	R/W
b3	—	Reserved bit	Set to 0.	R/W
b4	TRDIOC0SELO	TRDIOC0 pin select bit	0: TRDIOC0 pin not used 1: P3_7 assigned	R/W
b5	—	Reserved bit	Set to 0.	R/W
b6	TRDIOD0SELO	TRDIOD0 pin select bit	0: TRDIOD0 pin not used 1: P3_3 assigned	R/W
b7	—	Nothing is assigned. If necessary, set to 0. When read, the content is 0.		—

The TRDPSR0 register selects which pin is assigned to the timer RD I/O. To use the I/O pin for timer RD, set this register.

Set the TRDPSR0 register before setting the timer RD associated registers. Also, do not change the setting value in this register during timer RD operation.

20.6.14 Timer RD Pin Select Register 1 (TRDPSR1)

Address 0185h

Bit	b7	b6	b5	b4	b3	b2	b1	b0
Symbol	—	TRDIOD1SELO	—	TRDIOC1SELO	—	TRDIOB1SELO	—	TRDIOA1SELO
After Reset	0	0	0	0	0	0	0	0

Bit	Symbol	Bit Name	Function	R/W
b0	TRDIOA1SELO	TRDIOA1 pin select bit	0: TRDIOA1 pin not used 1: P1_0 assigned	R/W
b1	—	Nothing is assigned. If necessary, set to 0. When read, the content is 0.		—
b2	TRDIOB1SELO	TRDIOB1 pin select bit	0: TRDIOB1 pin not used 1: P1_1 assigned	R/W
b3	—	Nothing is assigned. If necessary, set to 0. When read, the content is 0.		—
b4	TRDIOC1SELO	TRDIOC1 pin select bit	0: TRDIOC1 pin not used 1: P1_2 assigned	R/W
b5	—	Reserved bit	Set to 0.	R/W
b6	TRDIOD1SELO	TRDIOD1 pin select bit	0: TRDIOD1 pin not used 1: P1_3 assigned	R/W
b7	—	Reserved bit	Set to 0.	R/W

The TRDPSR1 register selects which pin is assigned to the timer RD I/O. To use the I/O pin for timer RD, set this register.

Set the TRDPSR1 register before setting the timer RD associated registers. Also, do not change the setting value in this register during timer RD operation.

20.6.15 Operating Example

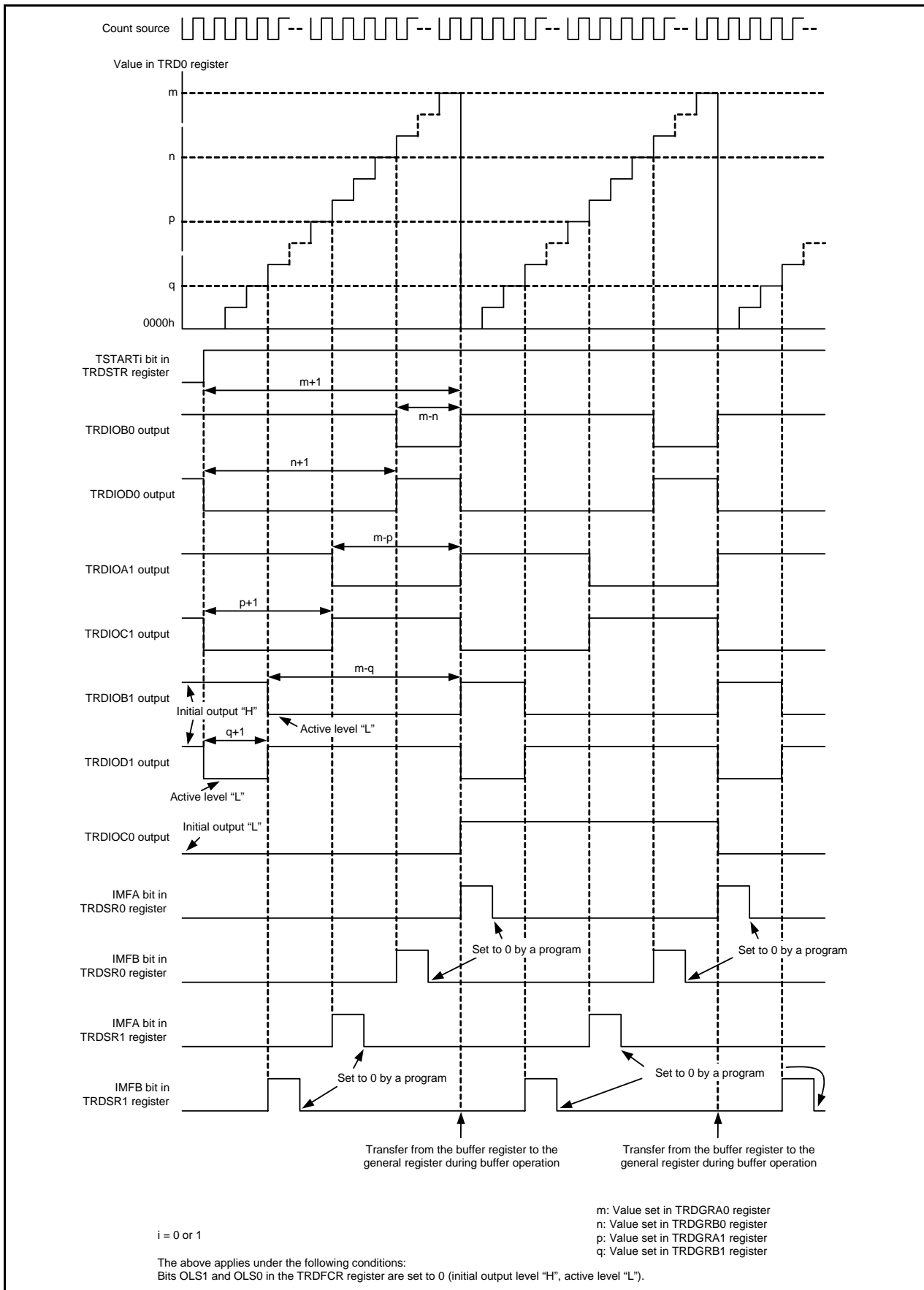

Figure 20.18 Operating Example of Reset Synchronous PWM Mode

20.6.16 A/D Trigger Generation

A compare match signal with registers TRDi (i = 0 or 1) and TRDGRji (j = A, B, C, or D) can be used as the conversion start trigger of the A/D converter.

The TRDADCR register is used to select which compare match is used.

20.7 Complementary PWM Mode

In this mode, 3 normal-phases and 3 counter-phases of the PWM waveform are output with the same period (three-phase, triangular wave modulation, and with dead time).

Figure 20.19 shows a Block Diagram of Complementary PWM Mode, and Table 20.13 lists the Complementary PWM Mode Specifications. Figure 20.20 shows Output Model of Complementary PWM Mode, and Figure 20.21 shows Operating Example of Complementary PWM Mode.

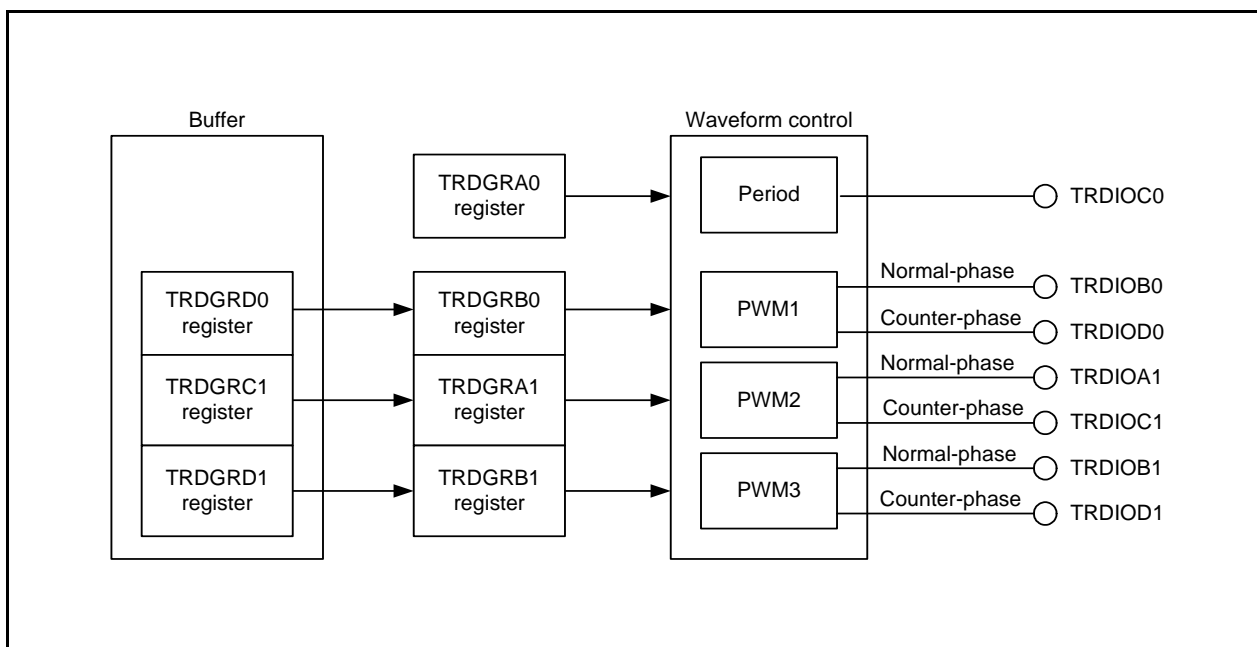

Figure 20.19 Block Diagram of Complementary PWM Mode

Table 20.13 Complementary PWM Mode Specifications

Item	Specification
Count sources	f1, f2, f4, f8, f32, fOCO40M, fOCO-F External signal input to the TRDCLK pin (valid edge selected by a program) Set bits TCK2 to TCK0 in the TRDCR1 register to the same value (same count source) as bits TCK2 to TCK0 in the TRDCR0 register.
Count operations	Increment or decrement Registers TRD0 and TRD1 are decremented with the compare match in registers TRD0 and TRDGRA0 during increment operation. The TRD1 register value is changed from 0000h to FFFFh during decrement operation, and registers TRD0 and TRD1 are incremented.
PWM operations	PWM period: $1/fk \times (m+2-p) \times 2$ ⁽¹⁾ Dead time: p Active level width of normal-phase: $1/fk \times (m-n-p+1) \times 2$ Active level width of counter-phase: $1/fk \times (n+1-p) \times 2$ fk: Frequency of count source m: Value set in the TRDGRA0 register n: Value set in the TRDGRB0 register (PWM1 output) Value set in the TRDGRA1 register (PWM2 output) Value set in the TRDGRB1 register (PWM3 output) p: Value set in the TRD0 register
Count start condition	1 (count starts) is written to bits TSTART0 and TSTART1 in the TRDSTR register.
Count stop conditions	0 (count stops) is written to bits TSTART0 and TSTART1 when the CSEL0 bit in the TRDSTR register is set to 1. (The PWM output pin outputs the initial output level selected by bits OLS0 and OLS1 in the TRDFCR register.)
Interrupt request generation timing	<ul style="list-style-type: none"> Compare match (The content of the TRDi register matches content of the TRDGRji register.) The TRD1 register underflows
TRDIOA0 pin function	Programmable I/O port or TRDCLK (external clock) input
TRDIOB0 pin function	PWM1 output normal-phase output
TRDIOD0 pin function	PWM1 output counter-phase output
TRDIOA1 pin function	PWM2 output normal-phase output
TRDIOC1 pin function	PWM2 output counter-phase output
TRDIOB1 pin function	PWM3 output normal-phase output
TRDIOD1 pin function	PWM3 output counter-phase output
TRDIOC0 pin function	Output inverted every 1/2 period of PWM
INT0 pin function	Programmable I/O port, pulse output forced cutoff signal input or INT0 interrupt input
Read from timer	The count value can be read by reading the TRDi register.
Write to timer	The value can be written to the TRDi register.
Selectable functions	<ul style="list-style-type: none"> Pulse output forced cutoff signal input (Refer to 20.2.4 Pulse Output Forced Cutoff.) The normal-phase and counter-phase active level and initial output level are selected individually. Transfer timing from the buffer register selection A/D trigger generation

i = 0 or 1, j = A, B, C, or D

Note:

1. After a count starts, the PWM period is fixed.

20.7.1 Module Standby Control Register (MSTCR)

Address 0008h

Bit	b7	b6	b5	b4	b3	b2	b1	b0
Symbol	—	—	MSTTRC	MSTTRD	MSTIIC	—	—	—
After Reset	0	0	0	0	0	0	0	0

Bit	Symbol	Bit Name	Function	R/W
b0	—	Nothing is assigned. If necessary, set to 0. When read, the content is 0.		—
b1	—			
b2	—			
b3	MSTIIC	SSU standby bit	0: Active 1: Standby ⁽¹⁾	R/W
b4	MSTTRD	Timer RD standby bit	0: Active 1: Standby ^(2, 3)	R/W
b5	MSTTRC	Timer RC standby bit	0: Active 1: Standby ⁽⁴⁾	R/W
b6	—	Reserved bit	Set to 0.	R/W
b7	—	Nothing is assigned. If necessary, set to 0. When read, the content is 0.		—

Notes:

1. Stop the SSU and the I²C bus functions before setting to standby. When the MSTIIC bit is set to 1 (standby), any access to the SSU associated registers (addresses 0193h to 019Dh) is disabled.
2. Stop the timer RD function before setting to standby. When the MSTTRD bit is set to 1 (standby), any access to the timer RD associated registers (addresses 0135h to 015Fh) is disabled.
3. To set the MSTTRD bit to 1 (standby), set bits TCK2 to TCK0 in the TRDCR_i (i = 0 or 1) register to 000b (f1).
4. Stop the timer RC function before setting to standby. When the MSTTRC bit is set to 1 (standby), any access to the timer RC associated registers (addresses 0120h to 0133h) is disabled.

20.7.2 Timer RD Trigger Control Register (TRDADCR) in Complementary PWM Mode

Address 0136h

Bit	b7	b6	b5	b4	b3	b2	b1	b0
Symbol	ADTRGD1E	ADTRGC1E	ADTRGB1E	ADTRGA1E	ADTRGD0E	ADTRGC0E	ADTRGB0E	ADTRGA0E
After Reset	0	0	0	0	0	0	0	0

Bit	Symbol	Bit Name	Function	R/W
b0	ADTRGA0E	A/D trigger A0 enable bit	Set to 0.	R/W
b1	ADTRGB0E	A/D trigger B0 enable bit	0: A/D trigger disabled 1: A/D trigger generated at compare match with registers TRD0 and TRDGRB0	R/W
b2	ADTRGC0E	A/D trigger C0 enable bit	0: A/D trigger disabled 1: A/D trigger generated at compare match with registers TRD0 and TRDGRC0	R/W
b3	ADTRGD0E	A/D trigger D0 enable bit	0: A/D trigger disabled 1: A/D trigger generated at compare match with registers TRD0 and TRDGRD0	R/W
b4	ADTRGA1E	A/D trigger A1 enable bit	0: A/D trigger disabled 1: A/D trigger generated at compare match with registers TRD1 and TRDGRA1	R/W
b5	ADTRGB1E	A/D trigger B1 enable bit	0: A/D trigger disabled 1: A/D trigger generated at compare match with registers TRD1 and TRDGRB1	R/W
b6	ADTRGC1E	A/D trigger C1 enable bit	0: A/D trigger disabled 1: A/D trigger generated at compare match with registers TRD1 and TRDGRC1	R/W
b7	ADTRGD1E	A/D trigger D1 enable bit	0: A/D trigger disabled 1: A/D trigger generated at compare match with registers TRD1 and TRDGRD1	R/W

20.7.3 Timer RD Start Register (TRDSTR) in Complementary PWM Mode

Address 0137h

Bit	b7	b6	b5	b4	b3	b2	b1	b0
Symbol	—	—	—	—	CSEL1	CSEL0	TSTART1	TSTART0
After Reset	1	1	1	1	1	1	0	0

Bit	Symbol	Bit Name	Function	R/W
b0	TSTART0	TRD0 count start flag ⁽³⁾	0: Count stops ⁽¹⁾ 1: Count starts	R/W
b1	TSTART1	TRD1 count start flag ⁽⁴⁾	0: Count stops ⁽²⁾ 1: Count starts	R/W
b2	CSEL0	TRD0 count operation select bit	0: Count stops at the compare match with the TRDGRA0 register 1: Count continues after the compare match with the TRDGRA0 register	R/W
b3	CSEL1	TRD1 count operation select bit	0: Count stops at the compare match with the TRDGRA1 register 1: Count continues after the compare match with the TRDGRA1 register	R/W
b4	—	Nothing is assigned. If necessary, set to 0. When read, the content is 1.		—
b5	—			
b6	—			
b7	—			

Notes:

1. When the CSEL0 bit is set to 1, write 0 to the TSTART0 bit.
2. When the CSEL1 bit is set to 1, write 0 to the TSTART1 bit.
3. When the CSEL0 bit is set to 0 and the compare match signal (TRDIOA0) is generated, this bit is set to 0 (count stops).
4. When the CSEL1 bit is set to 0 and the compare match signal (TRDIOA1) is generated, this bit is set to 0 (count stops).

Set the TRDSTR register using the MOV instruction (do not use the bit handling instruction). Refer to **20.10.1 TRDSTR Register** of **Notes on Timer RD**.

20.7.4 Timer RD Mode Register (TRDMR) in Complementary PWM Mode

Address 0138h

Bit	b7	b6	b5	b4	b3	b2	b1	b0
Symbol	BFD1	BFC1	BFD0	BFC0	—	—	—	SYNC
After Reset	0	0	0	0	1	1	1	0

Bit	Symbol	Bit Name	Function	R/W
b0	SYNC	Timer RD synchronous bit	Set this bit to 0 (registers TRD0 and TRD1 operate independently) in complementary PWM mode.	R/W
b1	—	Nothing is assigned. If necessary, set to 0. When read, the content is 1.		—
b2	—			
b3	—			
b4	BFC0	TRDGRC0 register function select bit	Set this bit to 0 (general register) in complementary PWM mode.	R/W
b5	BFD0	TRDGRD0 register function select bit	0: General register 1: Buffer register of TRDGRB0 register	R/W
b6	BFC1	TRDGRC1 register function select bit	0: General register 1: Buffer register of TRDGRA1 register	R/W
b7	BFD1	TRDGRD1 register function select bit	0: General register 1: Buffer register of TRDGRB1 register	R/W

20.7.5 Timer RD Function Control Register (TRDFCR) in Complementary PWM Mode

Address 013Ah

Bit	b7	b6	b5	b4	b3	b2	b1	b0
Symbol	PWM3	STCLK	ADEG	ADTRG	OLS1	OLS0	CMD1	CMD0
After Reset	1	0	0	0	0	0	0	0

Bit	Symbol	Bit Name	Function	R/W
b0	CMD0	Combination mode select bit (1, 2)	^{b1 b0} 1 0: Complementary PWM mode (transfer from the buffer register to the general register at the underflow in the TRD1 register) 1 1: Complementary PWM mode (transfer from the buffer register to the general register at the compare match with registers TRD0 and TRDGRA0.) Other than above: Do not set.	R/W
b1	CMD1			R/W
b2	OLS0	Normal-phase output level select bit (in reset synchronous PWM mode or complementary PWM mode)	0: Initial output "H", Active level "L" 1: Initial output "L", Active level "H"	R/W
b3	OLS1	Counter-phase output level select bit (in reset synchronous PWM mode or complementary PWM mode)	0: Initial output "H", Active level "L" 1: Initial output "L", Active level "H"	R/W
b4	ADTRG	A/D trigger enable bit (in complementary PWM mode)	0: Disable A/D trigger 1: Enable A/D trigger (3)	R/W
b5	ADEG	A/D trigger edge select bit (in complementary PWM mode)	0: A/D trigger is generated at compare match between registers TRD0 and TRDGRA0 1: A/D trigger is generated at underflow in the TRD1 register	R/W
b6	STCLK	External clock input select bit	0: External clock input disabled 1: External clock input enabled	R/W
b7	PWM3	PWM3 mode select bit (4)	This bit is disabled in complementary PWM mode.	R/W

Notes:

- When setting bits CMD1 to CMD0 to 10b or 11b, the MCU enters complementary PWM mode in spite of the setting of the TRDPMR register.
- Set bits CMD1 to CMD0 when both the TSTART0 and TSTART1 bits in the TRDSTR register are set to 0 (count stops).
- Set bits ADCAP1 to ADCAP0 in the ADMOD register to 01b (A/D conversion starts by conversion trigger from timer RD).
- When bits CMD1 to CMD0 are set to 00b (timer mode, PWM mode, or PWM3 mode), the setting of the PWM3 bit is enabled.

20.7.6 Timer RD Output Master Enable Register 1 (TRDOER1) in Complementary PWM Mode

Address 013Bh

Bit	b7	b6	b5	b4	b3	b2	b1	b0
Symbol	ED1	EC1	EB1	EA1	ED0	EC0	EB0	EA0
After Reset	1	1	1	1	1	1	1	1

Bit	Symbol	Bit Name	Function	R/W
b0	EA0	TRDIOA0 output disable bit	Set this bit to 1 (the TRDIOA0 pin is used as a programmable I/O port) in complementary PWM mode.	R/W
b1	EB0	TRDIOB0 output disable bit	0: Enable output 1: Disable output (The TRDIOB0 pin is used as a programmable I/O port.)	R/W
b2	EC0	TRDIOC0 output disable bit	0: Enable output 1: Disable output (The TRDIOC0 pin is used as a programmable I/O port.)	R/W
b3	ED0	TRDIOD0 output disable bit	0: Enable output 1: Disable output (The TRDIOD0 pin is used as a programmable I/O port.)	R/W
b4	EA1	TRDIOA1 output disable bit	0: Enable output 1: Disable output (The TRDIOA1 pin is used as a programmable I/O port.)	R/W
b5	EB1	TRDIOB1 output disable bit	0: Enable output 1: Disable output (The TRDIOB1 pin is used as a programmable I/O port.)	R/W
b6	EC1	TRDIOC1 output disable bit	0: Enable output 1: Disable output (The TRDIOC1 pin is used as a programmable I/O port.)	R/W
b7	ED1	TRDIOD1 output disable bit	0: Enable output 1: Disable output (The TRDIOD1 pin is used as a programmable I/O port.)	R/W

20.7.7 Timer RD Output Master Enable Register 2 (TRDOER2) in Complementary PWM Mode

Address 013Ch

Bit	b7	b6	b5	b4	b3	b2	b1	b0
Symbol	PTO	—	—	—	—	—	—	—
After Reset	0	1	1	1	1	1	1	1

Bit	Symbol	Bit Name	Function	R/W
b0	—	Nothing is assigned. If necessary, set to 0. When read, the content is 1.		—
b1	—			
b2	—			
b3	—			
b4	—			
b5	—			
b6	—			
b7	PTO	$\overline{\text{INT0}}$ of pulse output forced cutoff signal input enabled bit ⁽¹⁾	0: Pulse output forced cutoff input disabled 1: Pulse output forced cutoff input enabled (All bits in the TRDOER1 register are set to 1 (disable output) when "L" is applied to the $\overline{\text{INT0}}$ pin.)	R/W

Note:

1. Refer to **20.2.4 Pulse Output Forced Cutoff**.

20.7.8 Timer RD Control Register i (TRDCRi) (i = 0 or 1) in Complementary PWM Mode

Address 0140h (TRDCR0), 0150h (TRDCR1)

Bit	b7	b6	b5	b4	b3	b2	b1	b0
Symbol	CCLR2	CCLR1	CCLR0	CKEG1	CKEG0	TCK2	TCK1	TCK0
After Reset	0	0	0	0	0	0	0	0

Bit	Symbol	Bit Name	Function	R/W
b0	TCK0	Count source select bit (2)	b2 b1 b0 0 0 0: f1 0 0 1: f2 0 1 0: f4 0 1 1: f8 1 0 0: f32 1 0 1: TRDCLK input (1) 1 1 0: fOCO40M 1 1 1: fOCO-F (4)	R/W
b1	TCK1			R/W
b2	TCK2			R/W
b3	CKEG0			External clock edge select bit (2, 3)
b4	CKEG1	R/W		
b5	CCLR0	TRDi counter clear select bit	Set to 000b (disable clearing (free-running operation)) in complementary PWM mode.	R/W
b6	CCLR1			R/W
b7	CCLR2			R/W

Notes:

1. Enabled when the ITCLKi bit in the STCLK bit in the TRDFCR register is 1 (external clock input enabled).
2. Set bits TCK2 to TCK0 and bits CKEG1 to CKEG0 in registers TRDCR0 and TRDCR1 to the same values.
3. Enabled when bits TCK2 to TCK0 are set to 101b (TRDCLK input) and the STCLK bit in the TRDFCR register is set to 1 (external clock input enabled).
4. To select fOCO-F, set it to the clock frequency higher than the CPU clock frequency.

20.7.9 Timer RD Status Register i (TRDSRi) (i = 0 or 1) in Complementary PWM Mode

Address 0143h (TRDSR0), 0153h (TRDSR1)

Bit	b7	b6	b5	b4	b3	b2	b1	b0	
Symbol	—	—	UDF	OVF	IMFD	IMFC	IMFB	IMFA	
After Reset	1	1	1	0	0	0	0	0	TRDSR0 register
After Reset	1	1	0	0	0	0	0	0	TRDSR1 register

Bit	Symbol	Bit Name	Function	R/W
b0	IMFA	Input capture / compare match flag A	[Source for setting this bit to 0] Write 0 after read (2). [Source for setting this bit to 1] When the value in the TRDi register matches with the value in the TRDGRAi register.	R/W
b1	IMFB	Input capture / compare match flag B	[Source for setting this bit to 0] Write 0 after read (2). [Source for setting this bit to 1] When the value in the TRDi register matches with the value in the TRDGRBi register.	R/W
b2	IMFC	Input capture / compare match flag C	[Source for setting this bit to 0] Write 0 after read (2). [Source for setting this bit to 1] When the value in the TRDi register matches with the value in the TRDGRCi register (3).	R/W
b3	IMFD	Input capture / compare match flag D	[Source for setting this bit to 0] Write 0 after read (2). [Source for setting this bit to 1] When the value in the TRDi register matches with the value in the TRDGRDi register (3).	R/W
b4	OVF	Overflow flag	[Source for setting this bit to 0] Write 0 after read (2). [Source for setting this bit to 1] When the TRDi register overflows.	R/W
b5	UDF	Underflow flag (1)	[Source for setting this bit to 0] Write 0 after read (2). [Source for setting this bit to 1] When the TRD1 register underflows.	R/W
b6	—	Nothing is assigned. If necessary, set to 0. When read, the content is 1.		—
b7	—			—

Notes:

- Nothing is assigned to b5 in the TRDSR0 register. When writing to b5, write 0. When reading, the content is 1.
- The writing results are as follows:
 - This bit is set to 0 when the read result is 1 and 0 is written to the same bit.
 - This bit remains unchanged even if the read result is 0 and 0 is written to the same bit. (This bit remains 1 even if it is set to 1 from 0 after reading, and writing 0.)
 - This bit remains unchanged if 1 is written to it.
- Including when the BFji bit in the TRDMR register is set to 1 (TRDGRji is used as the buffer register).

20.7.10 Timer RD Interrupt Enable Register i (TRDIERi) (i = 0 or 1) in Complementary PWM Mode

Address 0144h (TRDIER0), 0154h (TRDIER1)

Bit	b7	b6	b5	b4	b3	b2	b1	b0
Symbol	—	—	—	OVIE	IMIED	IMIEC	IMIEB	IMIEA
After Reset	1	1	1	0	0	0	0	0

Bit	Symbol	Bit Name	Function	R/W
b0	IMIEA	Input capture/compare match interrupt enable bit A	0: Disable interrupt (IMIA) by the IMFA bit 1: Enable interrupt (IMIA) by the IMFA bit	R/W
b1	IMIEB	Input capture/compare match interrupt enable bit B	0: Disable interrupt (IMIB) by the IMFB bit 1: Enable interrupt (IMIB) by the IMFB bit	R/W
b2	IMIEC	Input capture/compare match interrupt enable bit C	0: Disable interrupt (IMIC) by the IMFC bit 1: Enable interrupt (IMIC) by the IMFC bit	R/W
b3	IMIED	Input capture/compare match interrupt enable bit D	0: Disable interrupt (IMID) by the IMFD bit 1: Enable interrupt (IMID) by the IMFD bit	R/W
b4	OVIE	Overflow/underflow interrupt enable bit	0: Disable interrupt (OVI) by the OVF or UDF bit 1: Enable interrupt (OVI) by the OVF or UDF bit	R/W
b5	—	Nothing is assigned. If necessary, set to 0. When read, the content is 1.		—
b6	—			
b7	—			

20.7.11 Timer RD Counter 0 (TRD0) in Complementary PWM Mode

Address 0147h to 0146h

Bit	b7	b6	b5	b4	b3	b2	b1	b0
Symbol	—	—	—	—	—	—	—	—
After Reset	0	0	0	0	0	0	0	0

Bit	b15	b14	b13	b12	b11	b10	b9	b8
Symbol	—	—	—	—	—	—	—	—
After Reset	0	0	0	0	0	0	0	0

Bit	Function	Setting Range	R/W
b15 to b0	Set the dead time. Count a count source. Count operation is incremented or decremented. When an overflow occurs, the OVF bit in the TRDSR0 register is set to 1.	0000h to FFFFh	R/W

Access the TRD0 register in 16-bit units. Do not access it in 8-bit units.

20.7.12 Timer RD Counter 1 (TRD1) in Complementary PWM Mode

Address 0157h to 0156h

Bit	b7	b6	b5	b4	b3	b2	b1	b0
Symbol	—	—	—	—	—	—	—	—
After Reset	0	0	0	0	0	0	0	0

Bit	b15	b14	b13	b12	b11	b10	b9	b8
Symbol	—	—	—	—	—	—	—	—
After Reset	0	0	0	0	0	0	0	0

Bit	Function	Setting Range	R/W
b15 to b0	Set 0000h. Count a count source. Count operation is incremented or decremented. When an underflow occurs, the UDF bit in the TRDSR1 register is set to 1.	0000h to FFFFh	R/W

Access the TRD1 register in 16-bit units. Do not access it in 8-bit units.

20.7.13 Timer RD General Registers Ai, Bi, C1, and Di (TRDGRAi, TRDGRBi, TRDGRC1, TRDGRDi) (i = 0 or 1) in Complementary PWM Mode

Address 0149h to 0148h (TRDGRA0), 014Bh to 014Ah (TRDGRB0),
014Fh to 014Eh (TRDGRD0),
0159h to 0158h (TRDGRA1), 015Bh to 015Ah (TRDGRB1),
015Dh to 015Ch (TRDGRC1), 015Fh to 015Eh (TRDGRD1)

Bit	b7	b6	b5	b4	b3	b2	b1	b0
Symbol	—	—	—	—	—	—	—	—
After Reset	1	1	1	1	1	1	1	1

Bit	b15	b14	b13	b12	b11	b10	b9	b8
Symbol	—	—	—	—	—	—	—	—
After Reset	1	1	1	1	1	1	1	1

Bit	Function	R/W
b15 to b0	Refer to Table 20.14 TRDGRji Register Functions in Complementary PWM Mode	R/W

Access registers TRDGRAi to TRDGRDi in 16-bit units. Do not access them in 8-bit units.
The TRDGRC0 register is not used in complementary PWM mode.

The following registers are disabled in the complementary PWM mode: TRDPMR, TRDOCR, TRDDF0, TRDDF1, TRDIORA0, TRDIORC0, TRDPOCR0, TRDIORA1, TRDIORC1, and TRDPOCR1.

Table 20.14 TRDGR*j*i Register Functions in Complementary PWM Mode

Register	Setting	Register Function	PWM Output Pin
TRDGRA0	–	General register. Set the PWM period at initialization. Setting range: Setting value or above in TRD0 register FFFFh - TRD0 register setting value or below Do not write to this register when the TSTART0 and TSTART1 bits in the TRDSTR register are set to 1 (count starts).	(Output inverted every half period of TRDIOC0 pin)
TRDGRB0	–	General register. Set the changing point of PWM1 output at initialization. Setting range: Setting value or above in TRD0 register TRDGRA0 register - TRD0 register setting value or below Do not write to this register when the TSTART0 and TSTART1 bits in the TRDSTR register are set to 1 (count starts).	TRDIOB0 TRDIOD0
TRDGRA1	–	General register. Set the changing point of PWM2 output at initialization. Setting range: Setting value or above in TRD0 register TRDGRA0 register - TRD0 register setting value or below Do not write to this register when the TSTART0 and TSTART1 bits in the TRDSTR register are set to 1 (count starts).	TRDIOA1 TRDIOC1
TRDGRB1	–	General register. Set the changing point of PWM3 output at initialization. Setting range: Setting value or above in TRD0 register TRDGRA0 register - TRD0 register setting value or below Do not write to this register when the TSTART0 and TSTART1 bits in the TRDSTR register are set to 1 (count starts).	TRDIOB1 TRDIOD1
TRDGRC0	–	This register is not used in complementary PWM mode.	–
TRDGRD0	BFD0 = 1	Buffer register. Set the changing point of next PWM1 output. (Refer to 20.2.2 Buffer Operation .) Setting range: Setting value or above in TRD0 register TRDGRA0 register - TRD0 register setting value or below Set this register to the same value as the TRDGRB0 register for initialization.	TRDIOB0 TRDIOD0
TRDGRC1	BFC1 = 1	Buffer register. Set the changing point of next PWM2 output. (Refer to 20.2.2 Buffer Operation .) Setting range: Setting value or above in TRD0 register TRDGRA0 register - TRD0 register setting value or below Set this register to the same value as the TRDGRA1 register for initialization.	TRDIOA1 TRDIOC1
TRDGRD1	BFD1 = 1	Buffer register. Set the changing point of next PWM3 output. (Refer to 20.2.2 Buffer Operation .) Setting range: Setting value or above in TRD0 register TRDGRA0 register - TRD0 register setting value or below Set this register to the same value as the TRDGRB1 register for initialization.	TRDIOB1 TRDIOD1

BFD0, BFC1, BFD1: Bits in TRDMR register

Since values cannot be written to the TRDGRB0, TRDGRA1, or TRDGRB1 register directly after count operation starts (prohibited item), use the TRDGRD0, TRDGRC1, or TRDGRD1 register as a buffer register. However, to write data to the TRDGRD0, TRDGRC1, or TRDGRD1 register, set bits BFD0, BFC1, and BFD1 to 0 (general register). After this, bits BFD0, BFC1, and BFD1 may be set to 1 (buffer register).

20.7.14 Timer RD Pin Select Register 0 (TRDPSR0)

Address 0184h

Bit	b7	b6	b5	b4	b3	b2	b1	b0
Symbol	—	TRDIOD0SELO	—	TRDIOC0SELO	—	TRDIOB0SELO	—	TRDIOA0SELO
After Reset	0	0	0	0	0	0	0	0

Bit	Symbol	Bit Name	Function	R/W
b0	TRDIOA0SELO	TRDIOA0/TRDCLK pin select bit	0: TRDIOA0/TRDCLK pin not used 1: P3_5 assigned	R/W
b1	—	Nothing is assigned. If necessary, set to 0. When read, the content is 0.		—
b2	TRDIOB0SELO	TRDIOB0 pin select bit	0: TRDIOB0 pin not used 1: P3_4 assigned	R/W
b3	—	Reserved bit	Set to 0.	R/W
b4	TRDIOC0SELO	TRDIOC0 pin select bit	0: TRDIOC0 pin not used 1: P3_7 assigned	R/W
b5	—	Reserved bit	Set to 0.	R/W
b6	TRDIOD0SELO	TRDIOD0 pin select bit	0: TRDIOD0 pin not used 1: P3_3 assigned	R/W
b7	—	Nothing is assigned. If necessary, set to 0. When read, the content is 0.		—

The TRDPSR0 register selects which pin is assigned to the timer RD I/O. To use the I/O pin for timer RD, set this register.

Set the TRDPSR0 register before setting the timer RD associated registers. Also, do not change the setting value in this register during timer RD operation.

20.7.15 Timer RD Pin Select Register 1 (TRDPSR1)

Address 0185h

Bit	b7	b6	b5	b4	b3	b2	b1	b0
Symbol	—	TRDIOD1SELO	—	TRDIOC1SELO	—	TRDIOB1SELO	—	TRDIOA1SELO
After Reset	0	0	0	0	0	0	0	0

Bit	Symbol	Bit Name	Function	R/W
b0	TRDIOA1SELO	TRDIOA1 pin select bit	0: TRDIOA1 pin not used 1: P1_0 assigned	R/W
b1	—	Nothing is assigned. If necessary, set to 0. When read, the content is 0.		—
b2	TRDIOB1SELO	TRDIOB1 pin select bit	0: TRDIOB1 pin not used 1: P1_1 assigned	R/W
b3	—	Nothing is assigned. If necessary, set to 0. When read, the content is 0.		—
b4	TRDIOC1SELO	TRDIOC1 pin select bit	0: TRDIOC1 pin not used 1: P1_2 assigned	R/W
b5	—	Reserved bit	Set to 0.	R/W
b6	TRDIOD1SELO	TRDIOD1 pin select bit	0: TRDIOD1 pin not used 1: P1_3 assigned	R/W
b7	—	Reserved bit	Set to 0.	R/W

The TRDPSR1 register selects which pin is assigned to the timer RD I/O. To use the I/O pin for timer RD, set this register.

Set the TRDPSR1 register before setting the timer RD associated registers. Also, do not change the setting value in this register during timer RD operation.

20.7.16 Operating Example

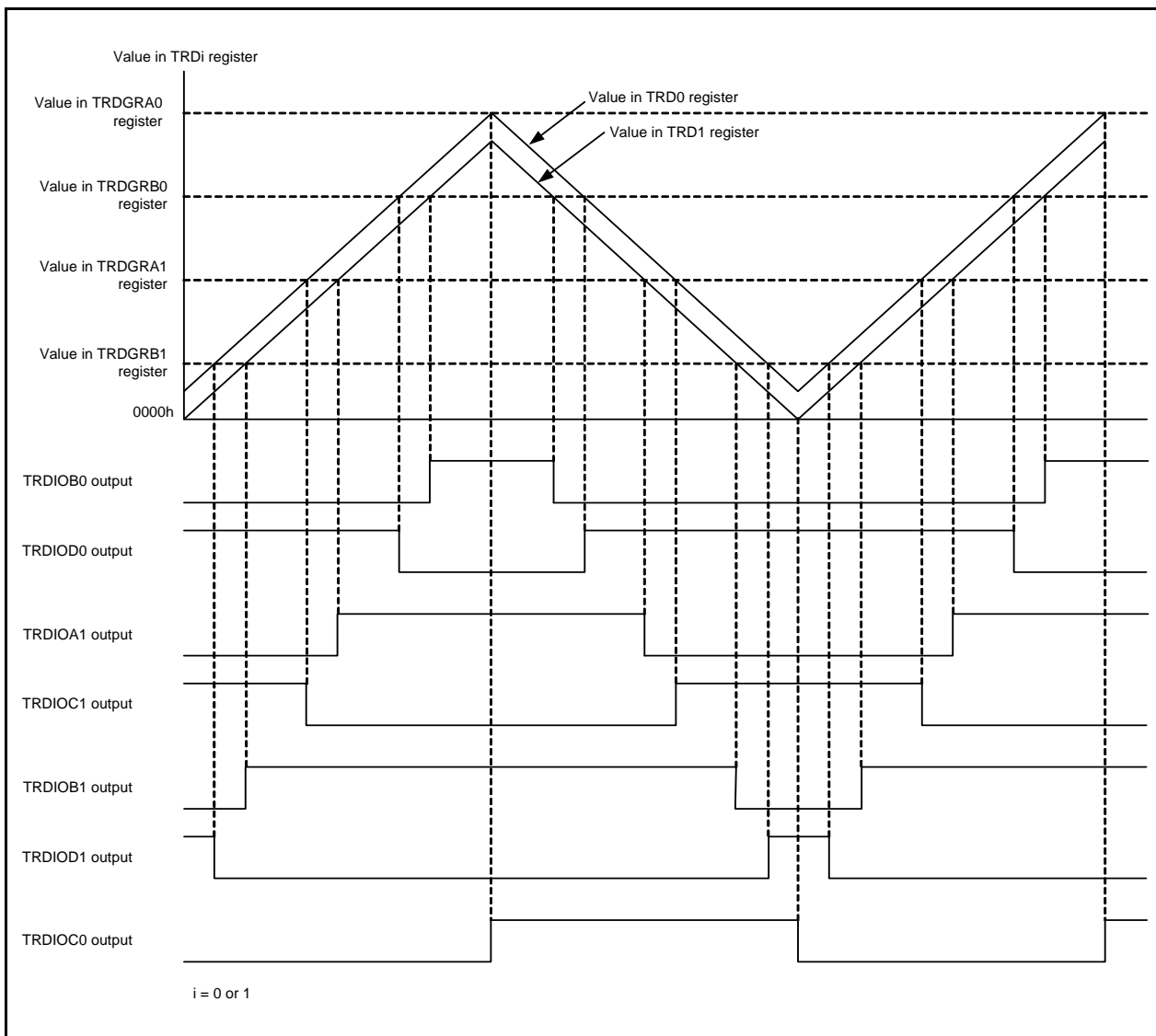

Figure 20.20 Output Model of Complementary PWM Mode

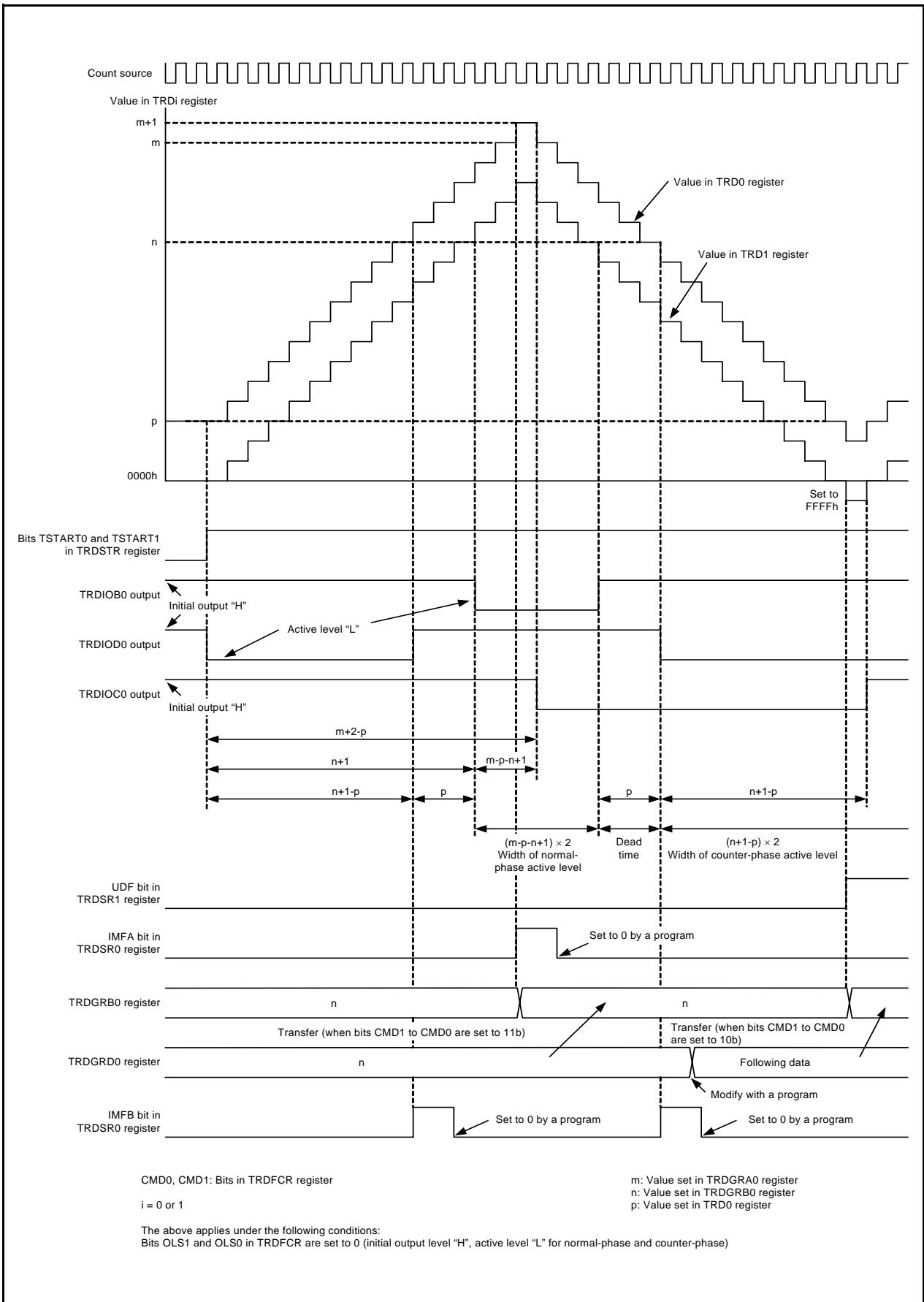

Figure 20.21 Operating Example of Complementary PWM Mode

20.7.17 Transfer Timing from Buffer Register

- Transfer from the TRDGRD0, TRDGRC1, or TRDGRD1 register to the TRDGRB0, TRDGRA1, or TRDGRB1 register.

When bits CMD1 to CMD0 in the TRDFCR register are set to 10b, the content is transferred when the TRD1 register underflows.

When bits CMD1 to CMD0 are set to 11b, the content is transferred at compare match between registers TRD0 and TRDGRA0.

20.7.18 A/D Trigger Generation

Compare match between registers TRD0 and TRDGRA0 and TRD1 underflow can be used as the conversion start trigger of the A/D converter.

Use bits ADEG and ADTRG in the TRDFCR register and the TRDADCR register to make settings.

In addition, set bits ADCAP1 to ADCAP0 in the ADMOD register to 01b (A/D conversion starts by conversion trigger from timer RD).

20.8 PWM3 Mode

In this mode, 2 PWM waveforms are output with the same period.

Figure 20.22 shows a Block Diagram of PWM3 Mode, and Table 20.15 lists the PWM3 Mode Specifications.

Figure 20.23 shows an Operating Example of PWM3 Mode.

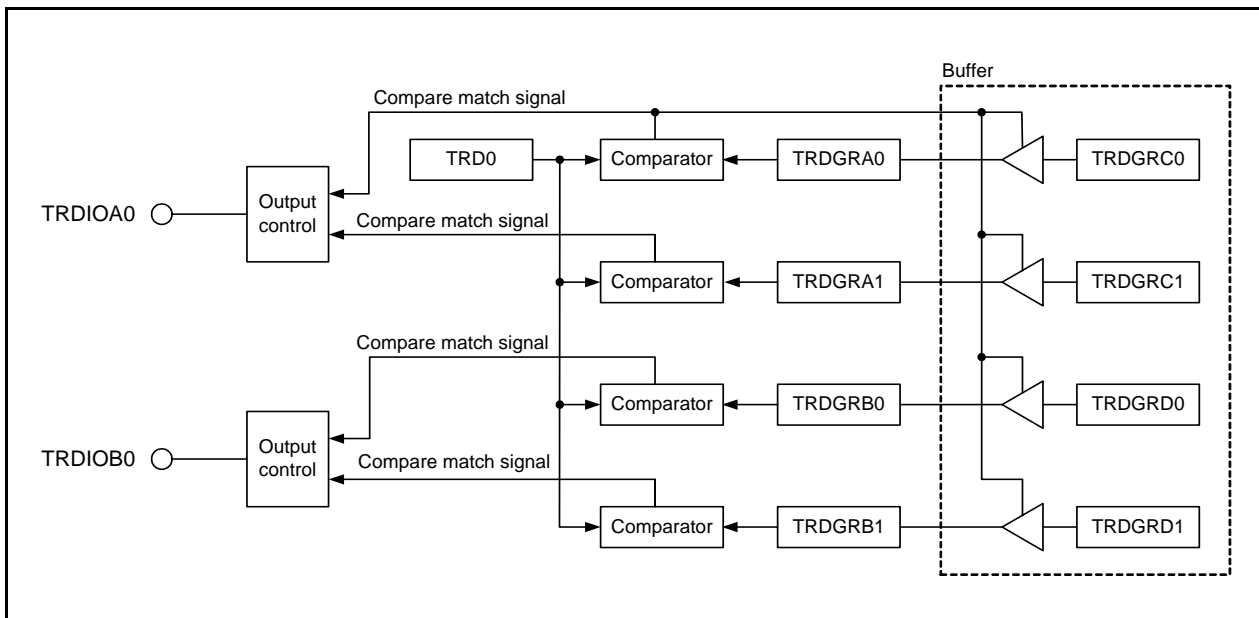

Figure 20.22 Block Diagram of PWM3 Mode

Table 20.15 PWM3 Mode Specifications

Item	Specification
Count sources	f1, f2, f4, f8, f32, fOCO40M, fOCO-F
Count operations	The TRD0 register is incremented (the TRD1 is not used).
PWM waveform	<p>PWM period: $1/f_k \times (m+1)$ Active level width of TRDIOA0 output: $1/f_k \times (m-n)$ Active level width of TRDIOB0 output: $1/f_k \times (p-q)$ f_k: Frequency of count source m: Value set in the TRDGRA0 register n: Value set in the TRDGRA1 register p: Value set in the TRDGRB0 register q: Value set in the TRDGRB1 register</p> <p style="text-align: right;">(When "H" is selected as the active level)</p>
Count start condition	1 (count starts) is written to the TSTART0 bit in the TRDSTR register.
Count stop conditions	<ul style="list-style-type: none"> • 0 (count stops) is written to the TSTART0 bit in the TRDSTR register when the CSEL0 bit in the TRDSTR register is set to 1. The PWM output pin holds output level before the count stops. • When the CSEL0 bit in the TRDSTR register is set to 0, the count stops at compare match with the TRDGRA0 register. The PWM output pin holds level after output change by compare match.
Interrupt request generation timing	<ul style="list-style-type: none"> • Compare match (The content of the TRDi register matches content of the TRDGRji register.) • The TRD0 register overflows
TRDIOA0, TRDIOB0 pin functions	PWM output
TRDIOC0, TRDIOD0, TRDIOA1 to TRDIOD1 pin functions	Programmable I/O port
INT0 pin function	Programmable I/O port, pulse output forced cutoff signal input, or INT0 interrupt input
Read from timer	The count value can be read by reading the TRD0 register.
Write to timer	The value can be written to the TRD0 register.
Selectable functions	<ul style="list-style-type: none"> • Pulse output forced cutoff signal input (Refer to 20.2.4 Pulse Output Forced Cutoff.) • Buffer operation (Refer to 20.2.2 Buffer Operation.) • Active level selectable for each pin • A/D trigger generation

i = 0 or 1, j = A, B, C, or D

20.8.1 Module Standby Control Register (MSTCR)

Address 0008h

Bit	b7	b6	b5	b4	b3	b2	b1	b0
Symbol	—	—	MSTTRC	MSTTRD	MSTIIC	—	—	—
After Reset	0	0	0	0	0	0	0	0

Bit	Symbol	Bit Name	Function	R/W
b0	—	Nothing is assigned. If necessary, set to 0. When read, the content is 0.		—
b1	—			
b2	—			
b3	MSTIIC	SSU standby bit	0: Active 1: Standby ⁽¹⁾	R/W
b4	MSTTRD	Timer RD standby bit	0: Active 1: Standby ^(2, 3)	R/W
b5	MSTTRC	Timer RC standby bit	0: Active 1: Standby ⁽⁴⁾	R/W
b6	—	Reserved bit	Set to 0.	R/W
b7	—	Nothing is assigned. If necessary, set to 0. When read, the content is 0.		—

Notes:

1. Stop the SSU and the I²C bus functions before setting to standby. When the MSTIIC bit is set to 1 (standby), any access to the SSU associated registers (addresses 0193h to 019Dh) is disabled.
2. Stop the timer RD function before setting to standby. When the MSTTRD bit is set to 1 (standby), any access to the timer RD associated registers (addresses 0135h to 015Fh) is disabled.
3. To set the MSTTRD bit to 1 (standby), set bits TCK2 to TCK0 in the TRDCR_i (i = 0 or 1) register to 000b (f1).
4. Stop the timer RC function before setting to standby. When the MSTTRC bit is set to 1 (standby), any access to the timer RC associated registers (addresses 0120h to 0133h) is disabled.

20.8.2 Timer RD Trigger Control Register (TRDADCR)

Address 0136h

Bit	b7	b6	b5	b4	b3	b2	b1	b0
Symbol	ADTRGD1E	ADTRGC1E	ADTRGB1E	ADTRGA1E	ADTRGD0E	ADTRGC0E	ADTRGB0E	ADTRGA0E
After Reset	0	0	0	0	0	0	0	0

Bit	Symbol	Bit Name	Function	R/W
b0	ADTRGA0E	A/D trigger A0 enable bit	0: A/D trigger disabled 1: A/D trigger generated at compare match with registers TRD0 and TRDGRA0	R/W
b1	ADTRGB0E	A/D trigger B0 enable bit	0: A/D trigger disabled 1: A/D trigger generated at compare match with registers TRD0 and TRDGRB0	R/W
b2	ADTRGC0E	A/D trigger C0 enable bit	0: A/D trigger disabled 1: A/D trigger generated at compare match with registers TRD0 and TRDGRC0	R/W
b3	ADTRGD0E	A/D trigger D0 enable bit	0: A/D trigger disabled 1: A/D trigger generated at compare match with registers TRD0 and TRDGRD0	R/W
b4	ADTRGA1E	A/D trigger A1 enable bit	0: A/D trigger disabled 1: A/D trigger generated at compare match with registers TRD1 and TRDGRA1	R/W
b5	ADTRGB1E	A/D trigger B1 enable bit	0: A/D trigger disabled 1: A/D trigger generated at compare match with registers TRD1 and TRDGRB1	R/W
b6	ADTRGC1E	A/D trigger C1 enable bit	0: A/D trigger disabled 1: A/D trigger generated at compare match with registers TRD1 and TRDGRC1	R/W
b7	ADTRGD1E	A/D trigger D1 enable bit	0: A/D trigger disabled 1: A/D trigger generated at compare match with registers TRD1 and TRDGRD1	R/W

20.8.3 Timer RD Start Register (TRDSTR) in PWM3 Mode

Address 0137h

Bit	b7	b6	b5	b4	b3	b2	b1	b0
Symbol	—	—	—	—	CSEL1	CSEL0	TSTART1	TSTART0
After Reset	1	1	1	1	1	1	0	0

Bit	Symbol	Bit Name	Function	R/W
b0	TSTART0	TRD0 count start flag ⁽³⁾	0: Count stops ⁽¹⁾ 1: Count starts	R/W
b1	TSTART1	TRD1 count start flag ⁽⁴⁾	0: Count stops ⁽²⁾ 1: Count starts	R/W
b2	CSEL0	TRD0 count operation select bit	0: Count stops at the compare match with the TRDGRA0 register 1: Count continues after the compare match with the TRDGRA0 register	R/W
b3	CSEL1	TRD1 count operation select bit [this bit is not used in PWM3 mode]	0: Count stops at the compare match with the TRDGRA1 register 1: Count continues after the compare match with the TRDGRA1 register	R/W
b4	—	Nothing is assigned. If necessary, set to 0. When read, the content is 1.		—
b5	—			
b6	—			
b7	—			

Notes:

1. When the CSEL0 bit is set to 1, write 0 to the TSTART0 bit.
2. When the CSEL1 bit is set to 1, write 0 to the TSTART1 bit.
3. When the CSEL0 bit is set to 0 and the compare match signal (TRDIOA0) is generated, this bit is set to 0 (count stops).
4. When the CSEL1 bit is set to 0 and the compare match signal (TRDIOA1) is generated, this bit is set to 0 (count stops).

Set the TRDSTR register using the MOV instruction (do not use the bit handling instruction). Refer to **20.10.1 TRDSTR Register** of **Notes on Timer RD**.

20.8.4 Timer RD Mode Register (TRDMR) in PWM3 Mode

Address 0138h

Bit	b7	b6	b5	b4	b3	b2	b1	b0
Symbol	BFD1	BFC1	BFD0	BFC0	—	—	—	SYNC
After Reset	0	0	0	0	1	1	1	0

Bit	Symbol	Bit Name	Function	R/W
b0	SYNC	Timer RD synchronous bit	Set this bit to 0 (TRD0 and TRD1 operate independently) in PWM3 mode.	R/W
b1	—	Nothing is assigned. If necessary, set to 0. When read, the content is 1.		—
b2	—			
b3	—			
b4	BFC0	TRDGRC0 register function select bit	0: General register 1: Buffer register of TRDGRA0 register	R/W
b5	BFD0	TRDGRD0 register function select bit	0: General register 1: Buffer register of TRDGRB0 register	R/W
b6	BFC1	TRDGRC1 register function select bit	0: General register 1: Buffer register of TRDGRA1 register	R/W
b7	BFD1	TRDGRD1 register function select bit	0: General register 1: Buffer register of TRDGRB1 register	R/W

20.8.5 Timer RD Function Control Register (TRDFCR) in PWM3 Mode

Address 013Ah

Bit	b7	b6	b5	b4	b3	b2	b1	b0
Symbol	PWM3	STCLK	ADEG	ADTRG	OLS1	OLS0	CMD1	CMD0
After Reset	1	0	0	0	0	0	0	0

Bit	Symbol	Bit Name	Function	R/W
b0	CMD0	Combination mode select bit ⁽¹⁾	Set to 00b (timer mode, PWM mode, or PWM3 mode) in PWM3 mode.	R/W
b1	CMD1			R/W
b2	OLS0	Normal-phase output level select bit (enabled in reset synchronous PWM mode or complementary PWM mode)	This bit is disabled in PWM3 mode.	R/W
b3	OLS1	Counter-phase output level select bit (enabled in reset synchronous PWM mode or complementary PWM mode)		R/W
b4	ADTRG	A/D trigger enable bit (enabled in complementary PWM mode)		R/W
b5	ADEG	A/D trigger edge select bit (enabled in complementary PWM mode)		R/W
b6	STCLK	External clock input select bit	Set this bit to 0 (external clock input disabled) in PWM3 mode.	R/W
b7	PWM3	PWM3 mode select bit ⁽²⁾	Set this bit to 0 (PWM3 mode) in PWM3 mode.	R/W

Notes:

1. Set bits CMD1 to CMD0 when both the TSTART0 and TSTART1 bits in the TRDSTR register are set to 0 (count stops).
2. When bits CMD1 to CMD0 are set to 00b (timer mode, PWM mode, or PWM3 mode), the setting of the PWM3 bit is enabled.

20.8.6 Timer RD Output Master Enable Register 1 (TRDOER1) in PWM3 Mode

Address 013Bh

Bit	b7	b6	b5	b4	b3	b2	b1	b0
Symbol	ED1	EC1	EB1	EA1	ED0	EC0	EB0	EA0
After Reset	1	1	1	1	1	1	1	1

Bit	Symbol	Bit Name	Function	R/W
b0	EA0	TRDIOA0 output disable bit	0: Enable output 1: Disable output (The TRDIOA0 pin is used as a programmable I/O port.)	R/W
b1	EB0	TRDIOB0 output disable bit	0: Enable output 1: Disable output (The TRDIOB0 pin is used as a programmable I/O port.)	R/W
b2	EC0	TRDIOC0 output disable bit	Set these bits to 1 (programmable I/O port) in PWM3 mode.	R/W
b3	ED0	TRDIOD0 output disable bit		R/W
b4	EA1	TRDIOA1 output disable bit		R/W
b5	EB1	TRDIOB1 output disable bit		R/W
b6	EC1	TRDIOC1 output disable bit		R/W
b7	ED1	TRDIOD1 output disable bit		R/W

20.8.7 Timer RD Output Master Enable Register 2 (TRDOER2) in PWM3 Mode

Address 013Ch

Bit	b7	b6	b5	b4	b3	b2	b1	b0
Symbol	PTO	—	—	—	—	—	—	—
After Reset	0	1	1	1	1	1	1	1

Bit	Symbol	Bit Name	Function	R/W
b0	—	Nothing is assigned. If necessary, set to 0. When read, the content is 1.		—
b1	—			
b2	—			
b3	—			
b4	—			
b5	—			
b6	—			
b7	PTO	$\overline{\text{INT0}}$ of pulse output forced cutoff signal input enabled bit ⁽¹⁾	0: Pulse output forced cutoff input disabled 1: Pulse output forced cutoff input enabled (All bits in the TRDOER1 register are set to 1 (disable output) when "L" is applied to the $\overline{\text{INT0}}$ pin.)	R/W

Note:

1. Refer to **20.2.4 Pulse Output Forced Cutoff**.

20.8.8 Timer RD Output Control Register (TRDOCR) in PWM3 Mode

Address 013Dh

Bit	b7	b6	b5	b4	b3	b2	b1	b0
Symbol	TOD1	TOC1	TOB1	TOA1	TOD0	TOC0	TOB0	TOA0
After Reset	0	0	0	0	0	0	0	0

Bit	Symbol	Bit Name	Function	R/W
b0	TOA0	TRDIOA0 output level select bit ⁽¹⁾	0: Active level "H", initial output "L", output "H" at compare match with the TRDGRA1 register, output "L" at compare match with the TRDGRA0 register 1: Active level "L", initial output "H", output "L" at compare match with the TRDGRA1 register, output "H" at compare match with the TRDGRA0 register	R/W
b1	TOB0	TRDIOB0 output level select bit ⁽¹⁾	0: Active level "H", initial output "L", output "H" at compare match with the TRDGRB1 register, output "L" at compare match with the TRDGRB0 register 1: Active level "L", initial output "H", output "L" at compare match with the TRDGRB1 register, output "H" at compare match with the TRDGRB0 register	R/W
b2	TOC0	TRDIOC0 initial output level select bit	These bits are disabled in PWM3 mode.	R/W
b3	TOD0	TRDIOD0 initial output level select bit		R/W
b4	TOA1	TRDIOA1 initial output level select bit		R/W
b5	TOB1	TRDIOB1 initial output level select bit		R/W
b6	TOC1	TRDIOC1 initial output level select bit		R/W
b7	TOD1	TRDIOD1 initial output level select bit		R/W

Note:

1. If the pin function is set for waveform output (refer to **7.5 Port Settings**), the initial output level is output when the TRDOCR register is set.

Write to the TRDOCR register when both bits TSTART0 and TSTART1 in the TRDSTR register are set to 0 (count stops).

20.8.9 Timer RD Control Register 0 (TRDCR0) in PWM3 Mode

Address 0140h

Bit	b7	b6	b5	b4	b3	b2	b1	b0
Symbol	CCLR2	CCLR1	CCLR0	CKEG1	CKEG0	TCK2	TCK1	TCK0
After Reset	0	0	0	0	0	0	0	0

Bit	Symbol	Bit Name	Function	R/W
b0	TCK0	Count source select bit	b2 b1 b0 0 0 0: f1 0 0 1: f2 0 1 0: f4 0 1 1: f8 1 0 0: f32 1 0 1: Do not set. 1 1 0: fOCO40M 1 1 1: fOCO-F ⁽¹⁾	R/W
b1	TCK1			R/W
b2	TCK2			R/W
b3	CKEG0	External clock edge select bit	These bits are disabled in PWM3 mode.	R/W
b4	CKEG1			R/W
b5	CCLR0	TRD0 counter clear select bit	Set to 001b (the TRD0 register cleared at compare match with TRDGRA0 register) in PWM3 mode.	R/W
b6	CCLR1			R/W
b7	CCLR2			R/W

Note:

1. To select fOCO-F, set it to the clock frequency higher than the CPU clock frequency.

The TRDCR1 register is not used in PWM3 mode.

20.8.10 Timer RD Status Register i (TRDSRi) (i = 0 or 1) in PWM3 Mode

Address 0143h (TRDSR0), 0153h (TRDSR1)

Bit	b7	b6	b5	b4	b3	b2	b1	b0	
Symbol	—	—	UDF	OVF	IMFD	IMFC	IMFB	IMFA	
After Reset	1	1	1	0	0	0	0	0	TRDSR0 register
After Reset	1	1	0	0	0	0	0	0	TRDSR1 register

Bit	Symbol	Bit Name	Function	R/W
b0	IMFA	Input capture / compare match flag A	[Source for setting this bit to 0] Write 0 after read ⁽²⁾ . [Source for setting this bit to 1] When the value in the TRDi register matches with the value in the TRDGRAi register.	R/W
b1	IMFB	Input capture / compare match flag B	[Source for setting this bit to 0] Write 0 after read ⁽²⁾ . [Source for setting this bit to 1] When the value in the TRDi register matches with the value in the TRDGRBi register.	R/W
b2	IMFC	Input capture / compare match flag C	[Source for setting this bit to 0] Write 0 after read ⁽²⁾ . [Source for setting this bit to 1] When the value in the TRDi register matches with the value in the TRDGRCi register ⁽³⁾ .	R/W
b3	IMFD	Input capture / compare match flag D	[Source for setting this bit to 0] Write 0 after read ⁽²⁾ . [Source for setting this bit to 1] When the value in the TRDi register matches with the value in the TRDGRDi register ⁽³⁾ .	R/W
b4	OVF	Overflow flag	[Source for setting this bit to 0] Write 0 after read ⁽²⁾ . [Source for setting this bit to 1] When the TRDi register overflows.	R/W
b5	UDF	Underflow flag ⁽¹⁾	This bit is disabled in PWM3 Mode.	R/W
b6	—	Nothing is assigned. If necessary, set to 0. When read, the content is 1.		—
b7	—			

Notes:

- Nothing is assigned to b5 in the TRDSR0 register. When writing to b5, write 0. When reading, the content is 1.
- The writing results are as follows:
 - This bit is set to 0 when the read result is 1 and 0 is written to the same bit.
 - This bit remains unchanged even if the read result is 0 and 0 is written to the same bit. (This bit remains 1 even if it is set to 1 from 0 after reading, and writing 0.)
 - This bit remains unchanged if 1 is written to it.
- Including when the BF_{ji} (j = C or D) bit in the TRDMR register is set to 1 (TRDGR_{ji} is used as the buffer register).

20.8.11 Timer RD Interrupt Enable Register i (TRDIERi) (i = 0 or 1) in PWM3 Mode

Address 0144h (TRDIER0), 0154h (TRDIER1)

Bit	b7	b6	b5	b4	b3	b2	b1	b0
Symbol	—	—	—	OVIE	IMIED	IMIEC	IMIEB	IMIEA
After Reset	1	1	1	0	0	0	0	0

Bit	Symbol	Bit Name	Function	R/W
b0	IMIEA	Input capture/compare match interrupt enable bit A	0: Disable interrupt (IMIA) by the IMFA bit 1: Enable interrupt (IMIA) by the IMFA bit	R/W
b1	IMIEB	Input capture/compare match interrupt enable bit B	0: Disable interrupt (IMIB) by the IMFB bit 1: Enable interrupt (IMIB) by the IMFB bit	R/W
b2	IMIEC	Input capture/compare match interrupt enable bit C	0: Disable interrupt (IMIC) by the IMFC bit 1: Enable interrupt (IMIC) by the IMFC bit	R/W
b3	IMIED	Input capture/compare match interrupt enable bit D	0: Disable interrupt (IMID) by the IMFD bit 1: Enable interrupt (IMID) by the IMFD bit	R/W
b4	OVIE	Overflow/underflow interrupt enable bit	0: Disable interrupt (OVI) by the OVF bit 1: Enable interrupt (OVI) by the OVF bit	R/W
b5	—	Nothing is assigned. If necessary, set to 0. When read, the content is 1.		—
b6	—			
b7	—			

20.8.12 Timer RD Counter 0 (TRD0) in PWM3 Mode

Address 0147h to 0146h

Bit	b7	b6	b5	b4	b3	b2	b1	b0
Symbol	—	—	—	—	—	—	—	—
After Reset	0	0	0	0	0	0	0	0

Bit	b15	b14	b13	b12	b11	b10	b9	b8
Symbol	—	—	—	—	—	—	—	—
After Reset	0	0	0	0	0	0	0	0

Bit	Function	Setting Range	R/W
b15 to b0	Count a count source. Count operation is incremented. When an overflow occurs, the OVF bit in the TRDSR0 register is set to 1.	0000h to FFFFh	R/W

Access the TRD0 register in 16-bit units. Do not access it in 8-bit units.
The TRD1 register is not used in PWM3 mode.

20.8.13 Timer RD General Registers Ai, Bi, Ci, and Di (TRDGRAi, TRDGRBi, TRDGRCi, TRDGRDi) (i = 0 or 1) in PWM3 Mode

Address 0149h to 0148h (TRDGRA0), 014Bh to 014Ah (TRDGRB0),
 014Dh to 014Ch (TRDGRC0), 014Fh to 014Eh (TRDGRD0),
 0159h to 0158h (TRDGRA1), 015Bh to 015Ah (TRDGRB1),
 015Dh to 015Ch (TRDGRC1), 015Fh to 015Eh (TRDGRD1)

Bit	b7	b6	b5	b4	b3	b2	b1	b0
Symbol	—	—	—	—	—	—	—	—
After Reset	1	1	1	1	1	1	1	1

Bit	b15	b14	b13	b12	b11	b10	b9	b8
Symbol	—	—	—	—	—	—	—	—
After Reset	1	1	1	1	1	1	1	1

Bit	Function	R/W
b15 to b0	Refer to Table 20.16 TRDGRji Register Functions in PWM3 Mode	R/W

Access registers TRDGRAi to TRDGRDi in 16-bit units. Do not access them in 8-bit units.

The following registers are disabled in the PWM3 mode function: TRDPMR, TRDDF0, TRDDF1, TRDIORA0, TRDIORC0, TRDPOCR0, TRDIORA1, TRDIORC1, and TRDPOCR1.

Table 20.16 TRDGR_{ji} Register Functions in PWM3 Mode

Register	Setting	Register Function	PWM Output Pin
TRDGRA0	–	General register. Set the PWM period. Setting range: Value set in TRDGRA1 register or above	TRDIOA0
TRDGRA1		General register. Set the changing point (the active level timing) of PWM output. Setting range: Value set in TRDGRA0 register or below	
TRDGRB0		General register. Set the changing point (the timing that returns to initial output level) of PWM output. Setting range: Value set in TRDGRB1 register or above Value set in TRDGRA0 register or below	TRDIOB0
TRDGRB1		General register. Set the changing point (active level timing) of PWM output. Setting range: Value set in TRDGRB0 register or below	
TRDGRC0	BFC0 = 0	(These registers is not used in PWM3 mode.)	–
TRDGRC1	BFC1 = 0		
TRDGRD0	BFD0 = 0		
TRDGRD1	BFD1 = 0		
TRDGRC0	BFC0 = 1	Buffer register. Set the next PWM period. (Refer to 20.2.2 Buffer Operation.) Setting range: Value set in TRDGRC1 register or above	TRDIOA0
TRDGRC1	BFC1 = 1	Buffer register. Set the changing point of next PWM output. (Refer to 20.2.2 Buffer Operation.) Setting range: Value set in TRDGRC0 register or below	
TRDGRD0	BFD0 = 1	Buffer register. Set the changing point of next PWM output. (Refer to 20.2.2 Buffer Operation.) Setting range: Value set in TRDGRD1 register or above, setting value or below in TRDGRC0 register.	TRDIOB0
TRDGRD1	BFD1 = 1	Buffer register. Set the changing point of next PWM output. (Refer to 20.2.2 Buffer Operation.) Setting range: Value set in TRDGRD0 register or below	

BFC0, BFD0, BFC1, BFD1: Bits in TRDMR register

Registers TRDGRC0, TRDGRC1, TRDGRD0, and TRDGRD1 are not used in PWM3 mode. To use them as buffer registers, set bits BFC0, BFC1, BFD0, and BFD1 to 0 (general register) and write a value to the TRDGRC0, TRDGRC1, TRDGRD0, or TRDGRD1 register. After this, bits BFC0, BFC1, BFD0, and BFD1 may be set to 1 (buffer register).

20.8.14 Timer RD Pin Select Register 0 (TRDPSR0)

Address 0184h

Bit	b7	b6	b5	b4	b3	b2	b1	b0
Symbol	—	TRDIOD0SELO	—	TRDIOC0SELO	—	TRDIOB0SELO	—	TRDIOA0SELO
After Reset	0	0	0	0	0	0	0	0

Bit	Symbol	Bit Name	Function	R/W
b0	TRDIOA0SELO	TRDIOA0/TRDCLK pin select bit	0: TRDIOA0/TRDCLK pin not used 1: P3_5 assigned	R/W
b1	—	Nothing is assigned. If necessary, set to 0. When read, the content is 0.		—
b2	TRDIOB0SELO	TRDIOB0 pin select bit	0: TRDIOB0 pin not used 1: P3_4 assigned	R/W
b3	—	Reserved bit	Set to 0.	R/W
b4	TRDIOC0SELO	TRDIOC0 pin select bit	0: TRDIOC0 pin not used 1: P3_7 assigned	R/W
b5	—	Reserved bit	Set to 0.	R/W
b6	TRDIOD0SELO	TRDIOD0 pin select bit	0: TRDIOD0 pin not used 1: P3_3 assigned	R/W
b7	—	Nothing is assigned. If necessary, set to 0. When read, the content is 0.		—

The TRDPSR0 register selects which pin is assigned to the timer RD I/O. To use the I/O pin for timer RD, set this register.

Set the TRDPSR0 register before setting the timer RD associated registers. Also, do not change the setting value in this register during timer RD operation.

20.8.15 Timer RD Pin Select Register 1 (TRDPSR1)

Address 0185h

Bit	b7	b6	b5	b4	b3	b2	b1	b0
Symbol	—	TRDIOD1SELO	—	TRDIOC1SELO	—	TRDIOB1SELO	—	TRDIOA1SELO
After Reset	0	0	0	0	0	0	0	0

Bit	Symbol	Bit Name	Function	R/W
b0	TRDIOA1SELO	TRDIOA1 pin select bit	0: TRDIOA1 pin not used 1: P1_0 assigned	R/W
b1	—	Nothing is assigned. If necessary, set to 0. When read, the content is 0.		—
b2	TRDIOB1SELO	TRDIOB1 pin select bit	0: TRDIOB1 pin not used 1: P1_1 assigned	R/W
b3	—	Nothing is assigned. If necessary, set to 0. When read, the content is 0.		—
b4	TRDIOC1SELO	TRDIOC1 pin select bit	0: TRDIOC1 pin not used 1: P1_2 assigned	R/W
b5	—	Reserved bit	Set to 0.	R/W
b6	TRDIOD1SELO	TRDIOD1 pin select bit	0: TRDIOD1 pin not used 1: P1_3 assigned	R/W
b7	—	Reserved bit	Set to 0.	R/W

The TRDPSR1 register selects which pin is assigned to the timer RD I/O. To use the I/O pin for timer RD, set this register.

Set the TRDPSR1 register before setting the timer RD associated registers. Also, do not change the setting value in this register during timer RD operation.

20.8.16 Operating Example

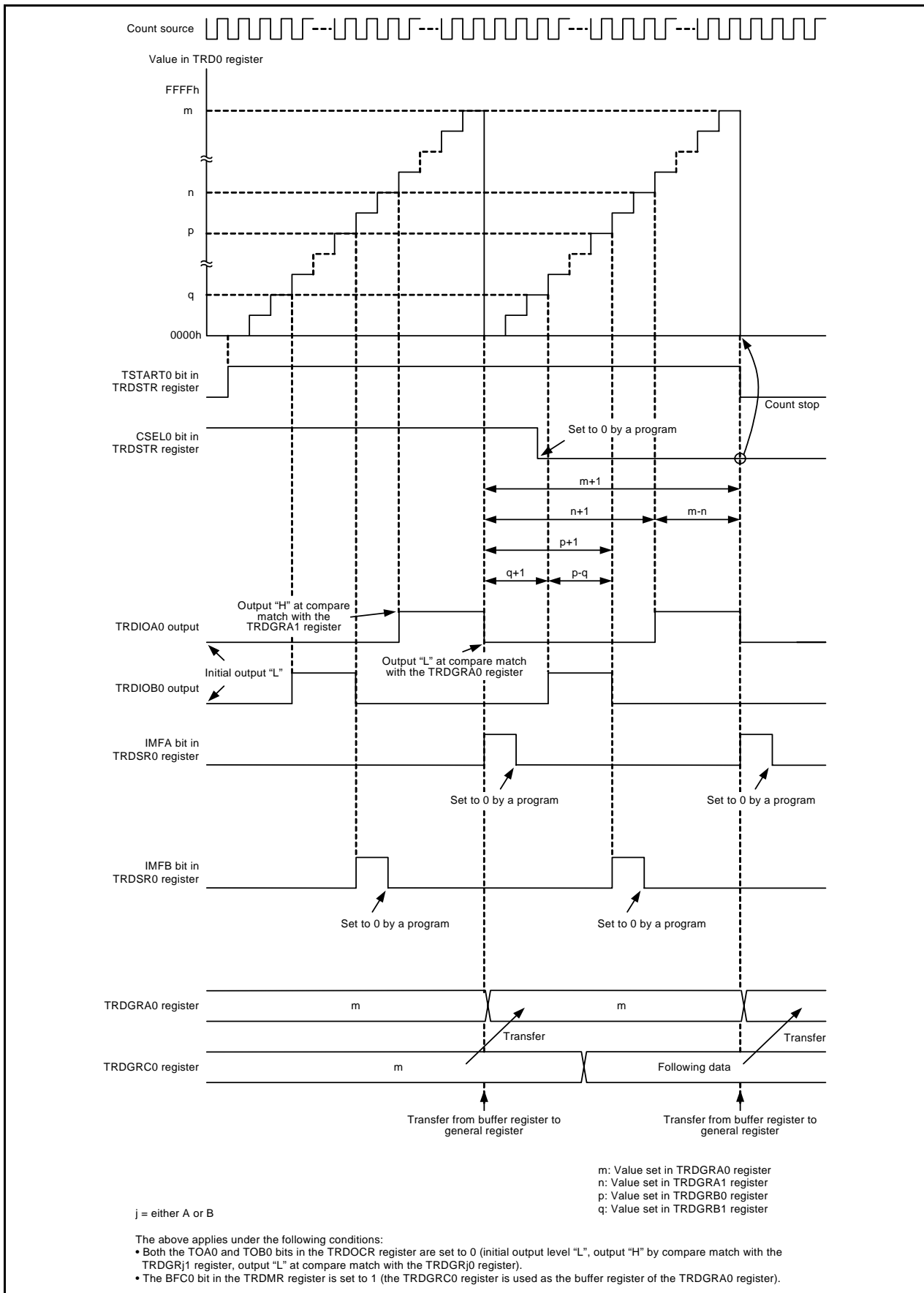

Figure 20.23 Operating Example of PWM3 Mode

20.8.17 A/D Trigger Generation

A compare match signal with registers TRDi (i = 0 or 1) and TRDGRji (j = A, B, C, or D) can be used as the conversion start trigger of the A/D converter.

The TRDADCR register is used to select which compare match is used.

20.9 Timer RD Interrupt

Timer RD generates the timer RD_i ($i = 0$ or 1) interrupt request from six sources for each timer RD0 and timer RD1. The timer RD interrupt has 1 TRDiIC register (bits IR, and ILVL0 to ILVL2), and 1 vector for each timer RD0 and timer RD1.

Table 20.17 lists the Registers Associated with Timer RD Interrupt, and Figure 20.24 shows a Block Diagram of Timer RD Interrupt.

Table 20.17 Registers Associated with Timer RD Interrupt

	Timer RD Status Register	Timer RD Interrupt Enable Register	Timer RD Interrupt Control Register
Timer RD0	TRDSR0	TRDIER0	TRD0IC
Timer RD1	TRDSR1	TRDIER1	TRD1IC

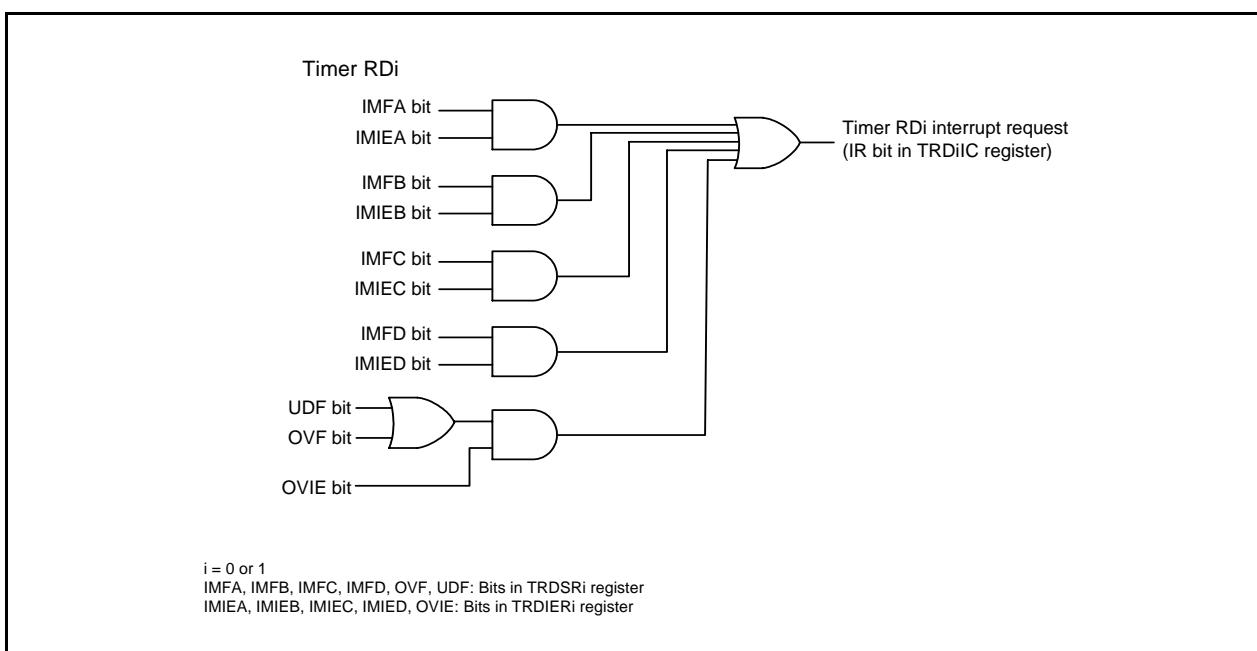

Figure 20.24 Block Diagram of Timer RD Interrupt

As with other maskable interrupts, the timer RD interrupt is controlled by the combination of the I flag, IR bit, bits ILVL0 to ILVL2, and IPL. However, since the interrupt source (timer RD interrupt) is generated by a combination of multiple interrupt request sources, the following differences from other maskable interrupts apply:

- When bits in the TRDSR_i register corresponding to bits set to 1 in the TRDIER_i register are set to 1 (enable interrupt), the IR bit in the TRDiIC register is set to 1 (interrupt requested).
- When either bits in the TRDSR_i register or bits in the TRDIER_i register corresponding to bits in the TRDSR_i register, or both of them, are set to 0, the IR bit is set to 0 (interrupt not requested). Therefore, even though the interrupt is not acknowledged after the IR bit is set to 1, the interrupt request will not be maintained.
- When the conditions of other request sources are met, the IR bit remains 1.
- When multiple bits in the TRDIER_i register are set to 1, which request source causes an interrupt is determined by the TRDSR_i register.
- Since each bit in the TRDSR_i register is not automatically set to 0 even if the interrupt is acknowledged, set each bit to 0 in the interrupt routine. For information on how to set these bits to 0, refer to **the descriptions of the registers used in the different modes (20.3.10, 20.4.13, 20.5.11, 20.6.9, 20.7.9, and 20.8.10)**.

Refer to **Registers TRDSR0 to TRDSR1 in each mode (20.3.10, 20.4.13, 20.5.11, 20.6.9, 20.7.9, and 20.8.10)** for the TRDSR_i register. Refer to **Registers TRDIER0 to TRDIER1 in each mode (20.3.11, 20.4.14, 20.5.12, 20.6.10, 20.7.10, and 20.8.11)** for the TRDIER_i register.

Refer to **11.3 Interrupt Control** for information on the TRDiIC register and **11.1.5.2 Relocatable Vector Tables** for the interrupt vectors.

20.10 Notes on Timer RD

20.10.1 TRDSTR Register

- Set the TRDSTR register using the MOV instruction.
- When the CSELi (i = 0 to 1) bit is set to 0 (the count stops at compare match of registers TRDi and TRDGRAi), the count does not stop and the TSTARTi bit remains unchanged even if 0 (count stops) is written to the TSTARTi bit.
Therefore, set the TSTARTi bit to 0 to change other bits without changing the TSTARTi bit when the CSELi bit is set to 0.
To stop counting by a program, set the TSTARTi bit after setting the CSELi bit to 1. Although the CSELi bit is set to 1 and the TSTARTi bit is set to 0 at the same time (with 1 instruction), the count cannot be stopped.
- Table 20.18 lists the TRDIOji (j = A, B, C, or D) Pin Output Level when Count Stops to use the TRDIOji (j = A, B, C, or D) pin with the timer RD output.

Table 20.18 TRDIOji (j = A, B, C, or D) Pin Output Level when Count Stops

Count Stop	TRDIOji Pin Output when Count Stops
When the CSELi bit is set to 1, set the TSTARTi bit to 0 and the count stops.	The pin holds the output level immediately before the count stops. (The pin outputs the initial output level selected by bits OLS0 and OLS1 in the TRDFCR register in complementary and reset synchronous PWM modes.)
When the CSELi bit is set to 0, the count stops at compare match of registers TRDi and TRDGRAi.	The pin holds the output level after the output changes by compare match. (The pin outputs the initial output level selected by bits OLS0 and OLS1 in the TRDFCR register in complementary and reset synchronous PWM modes.)

20.10.2 TRDi Register (i = 0 or 1)

- When writing the value to the TRDi register by a program while the TSTARTi bit in the TRDSTR register is set to 1 (count starts), avoid overlapping with the timing for setting the TRDi register to 0000h, and then write.
If the timing for setting the TRDi register to 0000h overlaps with the timing for writing the value to the TRDi register, the value is not written and the TRDi register is set to 0000h.
These precautions are applicable when selecting the following by bits CCLR2 to CCLR0 in the TRDCRi register.
 - 001b (Clear the TRDi register by input capture/compare match in the TRDGRAi register.)
 - 010b (Clear the TRDi register by input capture/compare match in the TRDGRBi register.)
 - 011b (Synchronous clear)
 - 101b (Clear the TRDi register by input capture/compare match in the TRDGRCi register.)
 - 110b (Clear the TRDi register by input capture/compare match in the TRDGRDi register.)
- When writing the value to the TRDi register and continuously reading the same register, the value before writing may be read. In this case, execute the JMP.B instruction between the writing and reading.

```

Program example      MOV.W    #XXXXh, TRD0      ;Writing
                    JMP.B    L1                          ;JMP.B
                    L1:     MOV.W    TRD0,DATA            ;Reading

```

20.10.3 TRDSRi Register (i = 0 or 1)

When writing the value to the TRDSRi register and continuously reading the same register, the value before writing may be read. In this case, execute the JMP.B instruction between the writing and reading.

```

Program example      MOV.B    #XXh, TRDSR0      ;Writing
                    JMP.B    L1                          ;JMP.B
                    L1:     MOV.B    TRDSR0,DATA      ;Reading

```

20.10.4 TRDCRi Register (i = 0 or 1)

To set bits TCK2 to TCK0 in the TRDCRi register to 111b (fOCO-F), set fOCO-F to the clock frequency higher than the CPU clock frequency.

20.10.5 Count Source Switch

- Switch the count source after the count stops.

Switching procedure

- (1) Set the TSTART_i (i = 0 or 1) bit in the TRDSTR register to 0 (count stops).
- (2) Change bits TCK2 to TCK0 in the TRDCR_i register.

- When changing the count source from fOCO40M to another clock other than fOCO-F and stopping fOCO40M, wait 2 cycles of f_l or more after setting the clock switch, and then stop fOCO40M.

Switching procedure

- (1) Set the TSTART_i (i = 0 or 1) bit in the TRDSTR register to 0 (count stops).
- (2) Change bits TCK2 to TCK0 in the TRDCR_i register.
- (3) Wait 2 or more cycles of f_l.
- (4) Set the FRA00 bit in the FRA0 register to 0 (high-speed on-chip oscillator stops).

- After switching the count source from fOCO-F to a clock other than fOCO40M, allow a minimum of one cycle of fOCO-F + fOCO40M to elapse after changing the clock setting before stopping fOCO-F.

Switching procedure

- (1) Set the TSTART_i (i = 0 to 1) bit in the TRDSTR register to 0 (count stops).
- (2) Change the settings of bits TCK2 to TCK0 in the TRDCR_i register.
- (3) Wait for a minimum of one cycle of fOCO-F + fOCO40M.
- (4) Set the FRA00 bit in the FRA0 register to 0 (high-speed on-chip oscillator off).

20.10.6 Input Capture Function

- Set the pulse width of the input capture signal to 3 or more cycles of the timer RD operation clock (refer to **Table 20.1 Timer RD Operation Clocks**).
- The value in the TRD_i register is transferred to the TRDGR_{ji} register 2 to 3 cycles of the timer RD operation clock after the input capture signal is applied to the TRDIO_{ji} (i = 0 or 1, j = A, B, C, or D) pin (no digital filter).
- When the input capture function is used, if an edge selected by bits IO_j0 and IO_j1 in the TRDIOR_{Ai} or TRDIOR_{Ci} register (i = 0 or 1, j = A, B, C, or D) is input to the TRDIO_{ji} pin, the IMF_j bit in the TRDSR_i register is set to 1 even when the TSTART_i bit in the TRDSTR register is 0 (count stops).

20.10.7 Reset Synchronous PWM Mode

- When reset synchronous PWM mode is used for motor control, make sure OLS0 = OLS1.
- Set to reset synchronous PWM mode by the following procedure:

Switching procedure

- (1) Set the TSTART0 bit in the TRDSTR register to 0 (count stops).
- (2) Set bits CMD1 to CMD0 in the TRDFCR register to 00b (timer mode, PWM mode, and PWM3 mode).
- (3) Set bits CMD1 to CMD0 to 01b (reset synchronous PWM mode).
- (4) Set the other registers associated with timer RD again.

20.10.8 Complementary PWM Mode

- When complementary PWM mode is used for motor control, make sure OLS0 = OLS1.

- Change bits CMD1 to CMD0 in the TRDFCR register in the following procedure.

Switching procedure: When setting to complementary PWM mode (including re-set), or changing the transfer timing from the buffer register to the general register in complementary PWM mode.

- (1) Set both the TSTART0 and TSTART1 bits in the TRDSTR register to 0 (count stops).
- (2) Set bits CMD1 to CMD0 in the TRDFCR register to 00b (timer mode, PWM mode, and PWM3 mode).
- (3) Set bits CMD1 to CMD0 to 10b or 11b (complementary PWM mode).
- (4) Set the registers associated with other timer RD again.

Switching procedure: When stopping complementary PWM mode

- (1) Set both the TSTART0 and TSTART1 bits in the TRDSTR register to 0 (count stops).
- (2) Set bits CMD1 to CMD0 to 00b (timer mode, PWM mode, and PWM3 mode).

- Do not write to TRDGRA0, TRDGRB0, TRDGRA1, or TRDGRB1 register during operation.

When changing the PWM waveform, transfer the values written to registers TRDGRD0, TRDGRC1, and TRDGRD1 to registers TRDGRB0, TRDGRA1, and TRDGRB1 using the buffer operation.

However, to write data to the TRDGRD0, TRDGRC1, or TRDGRD1 register, set bits BFD0, BFC1, and BFD1 to 0 (general register). After this, bits BFD0, BFC1, and BFD1 may be set to 1 (buffer register).

The PWM period cannot be changed.

- If the value in the TRDGRA0 register is assumed to be m , the TRD0 register counts $m-1$, m , $m+1$, m , $m-1$, in that order, when changing from increment to decrement operation.

When changing from m to $m+1$, the IMFA bit is set to 1. Also, bits CMD1 to CMD0 in the TRDFCR register are set to 11b (complementary PWM mode, buffer data transferred at compare match between registers TRD0 and TRDGRA0), the content in the buffer registers (TRDGRD0, TRDGRC1, and TRDGRD1) is transferred to the general registers (TRDGRB0, TRDGRA1, and TRDGRB1).

During $m+1$, m , and $m-1$ operation, the IMFA bit remains unchanged and data are not transferred to registers such as the TRDGRA0 register.

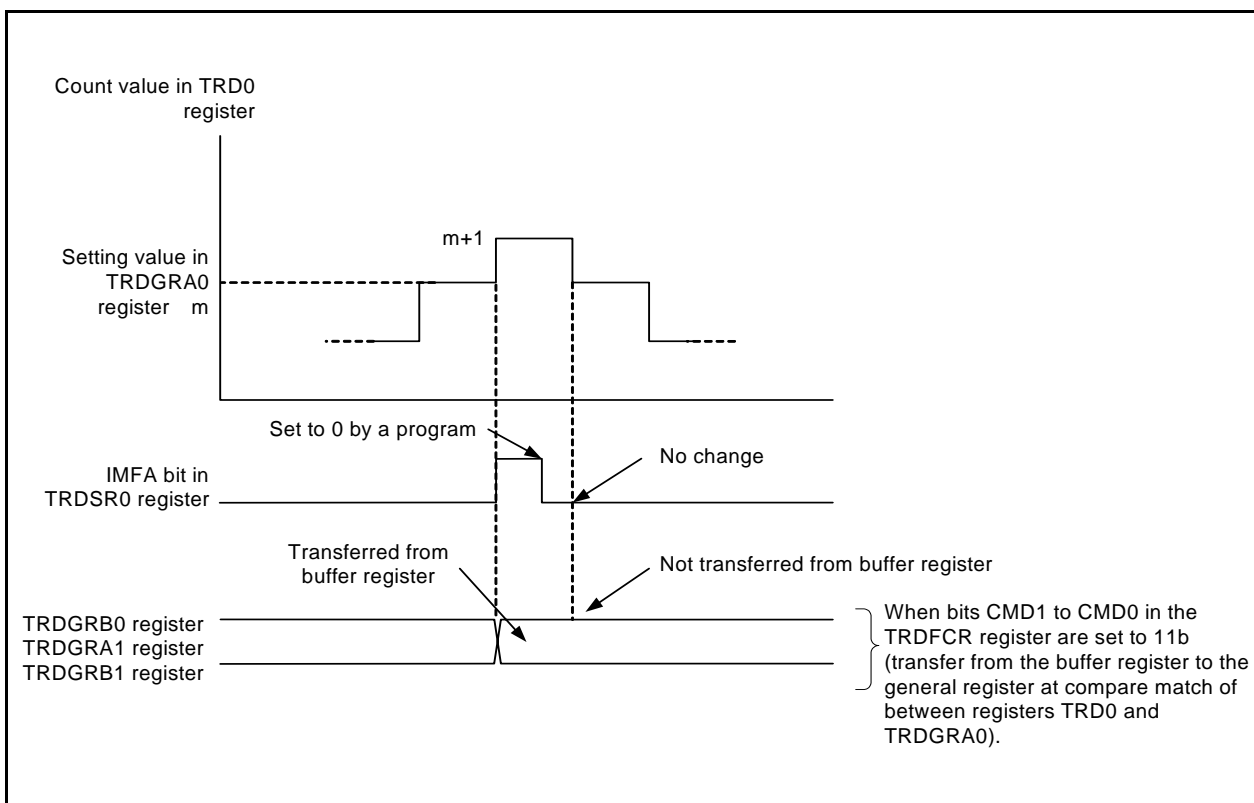

Figure 20.25 Operation at Compare Match between Registers TRD0 and TRDGRA0 in Complementary PWM Mode

- The TRD1 register counts 1, 0, FFFFh, 0, 1, in that order, when changing from decrement to increment operation.

The UDF bit is set to 1 when changing between 1, 0, and FFFFh operation. Also, when bits CMD1 to CMD0 in the TRDFCR register are set to 10b (complementary PWM mode, buffer data transferred at underflow in the TRD1 register), the content in the buffer registers (TRDGRD0, TRDGRC1, and TRDGRD1) is transferred to the general registers (TRDGRB0, TRDGRA1, and TRDGRB1). During FFFFh, 0, 1 operation, data are not transferred to registers such as the TRDGRB0 register. Also, at this time, the OVF bit remains unchanged.

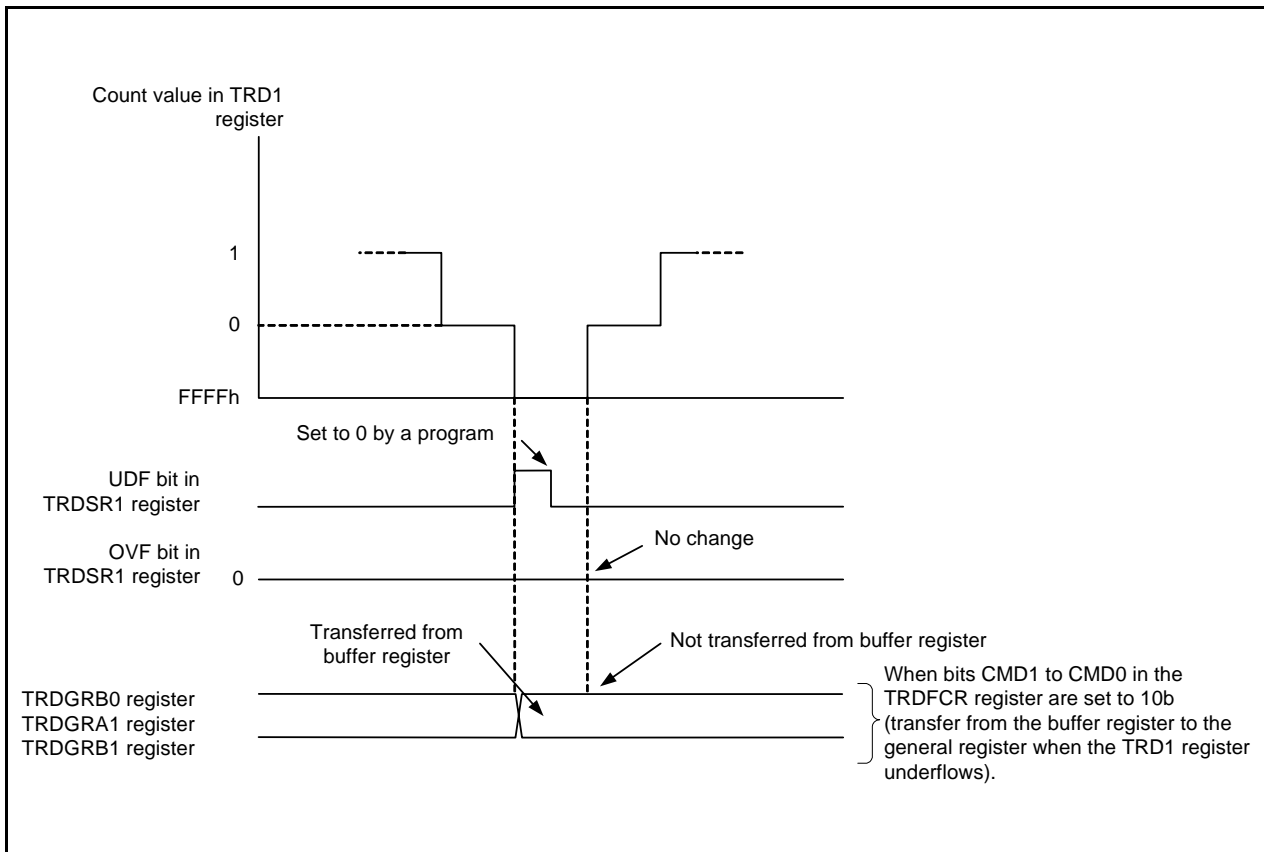

Figure 20.26 Operation when TRD1 Register Underflows in Complementary PWM Mode

- Select with bits CMD1 to CMD0 the timing of data transfer from the buffer register to the general register. However, transfer takes place with the following timing in spite of the value of bits CMD1 to CMD0 in the following cases:

Value in buffer register \geq value in TRDGRA0 register:

Transfer takes place at underflow of the TRD1 register.

After this, when the buffer register is set to 0001h or above and a smaller value than the value of the TRDGRA0 register, and the TRD1 register underflows for the first time after setting, the value is transferred to the general register. After that, the value is transferred with the timing selected by bits CMD1 to CMD0.

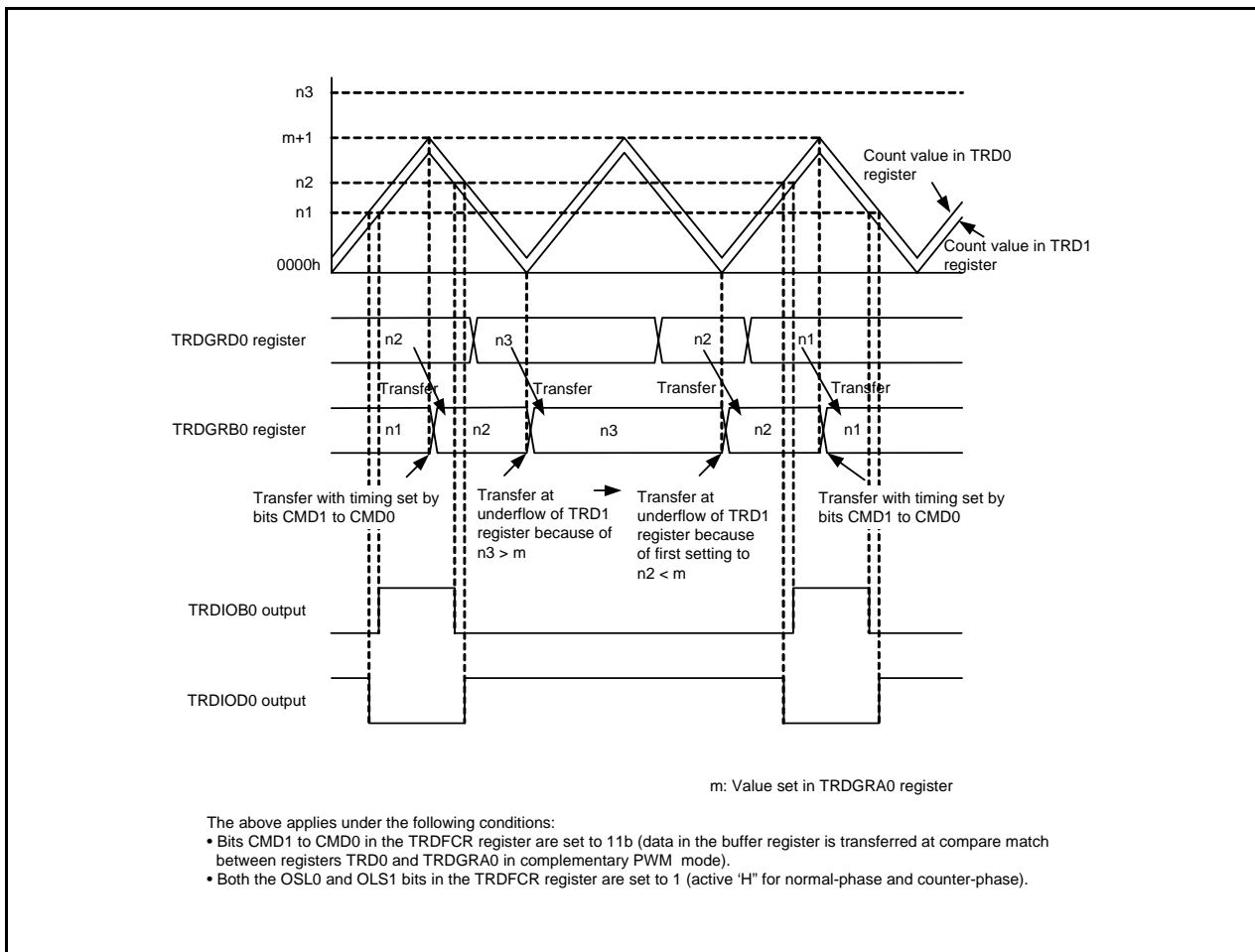

Figure 20.27 Operation when Value in Buffer Register \geq Value in TRDGRA0 Register in Complementary PWM Mode

When the value in the buffer register is set to 0000h:

Transfer takes place at compare match between registers TRD0 and TRDGRA0.

After this, when the buffer register is set to 0001h or above and a smaller value than the value of the TRDGRA0 register, and a compare match occurs between registers TRD0 and TRDGRA0 for the first time after setting, the value is transferred to the general register. After that, the value is transferred with the timing selected by bits CMD1 to CMD0.

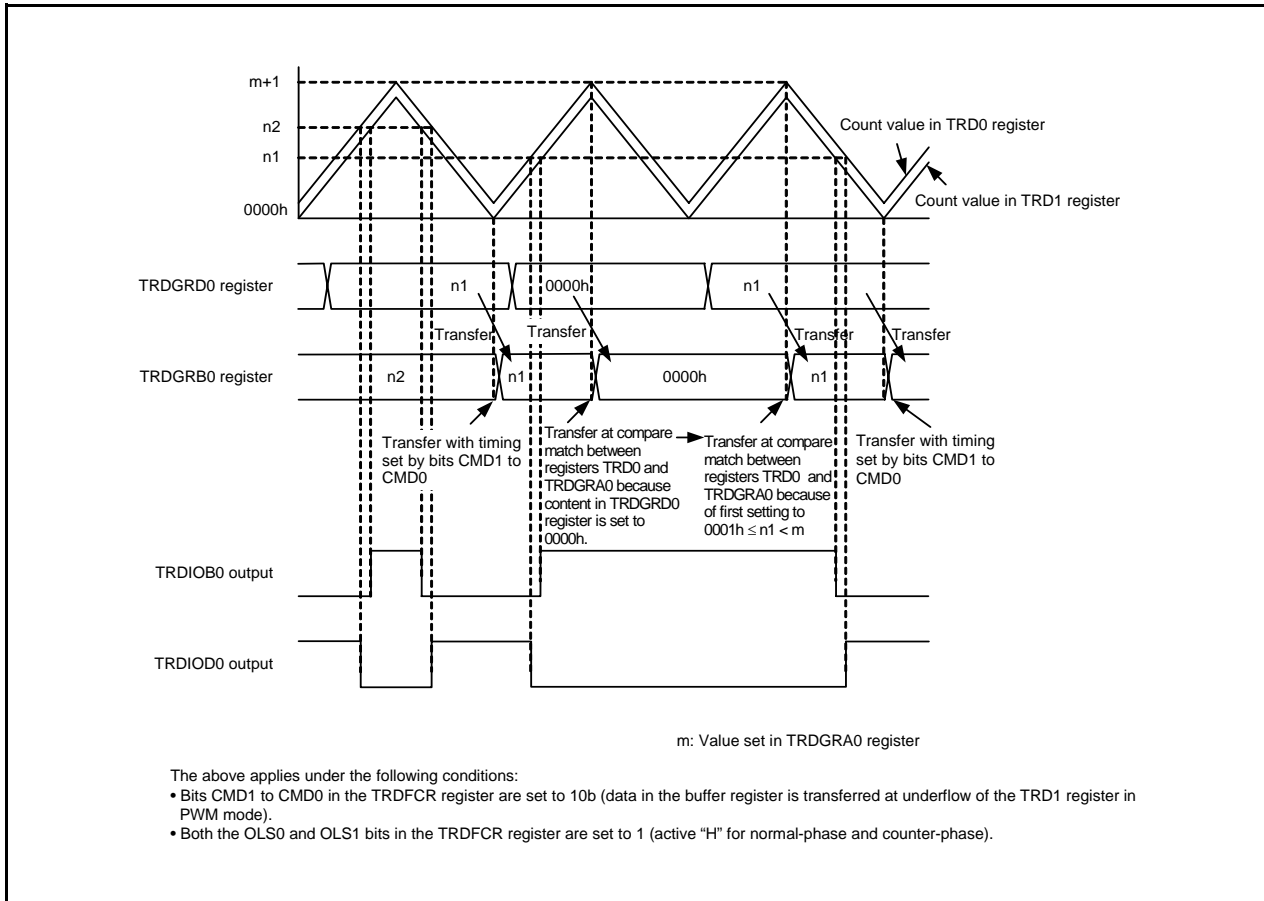

Figure 20.28 Operation when Value in Buffer Register Is Set to 0000h in Complementary PWM Mode

20.10.9 Count Source fOCO40M

The count source fOCO40M can be used with supply voltage $VCC = 2.7$ to 5.5 V. For supply voltage other than that, do not set bits TCK2 to TCK0 in registers TRDCR0 and TRDCR to 110b (select fOCO40M as the count source).

21. Serial Interface (UART0)

The serial interface consists of two channels, UART0, UART2. This chapter describes the UART0.

21.1 Overview

UART0 has a dedicated timer to generate a transfer clock and operate independently. UART0 supports clock synchronous serial I/O mode and clock asynchronous serial I/O mode (UART mode).

Figure 21.1 shows a UART0 Block Diagram. Figure 21.2 shows a Block Diagram of UART0 Transmit/Receive Unit. Table 21.1 lists the Pin Configuration of UART0.

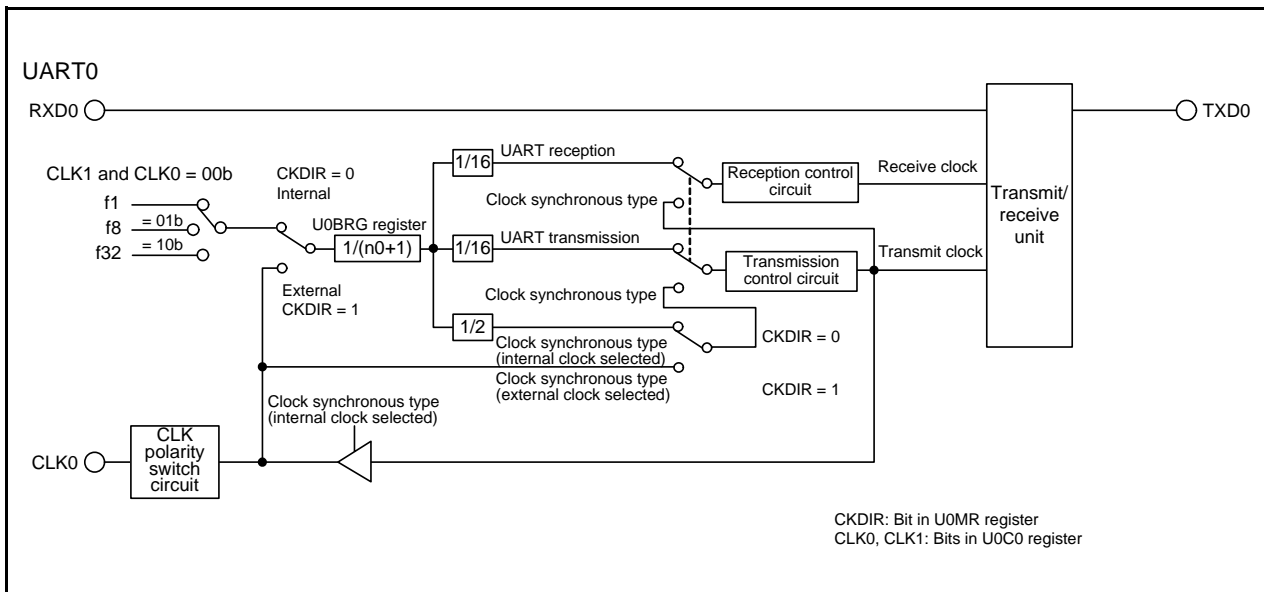

Figure 21.1 UART0 Block Diagram

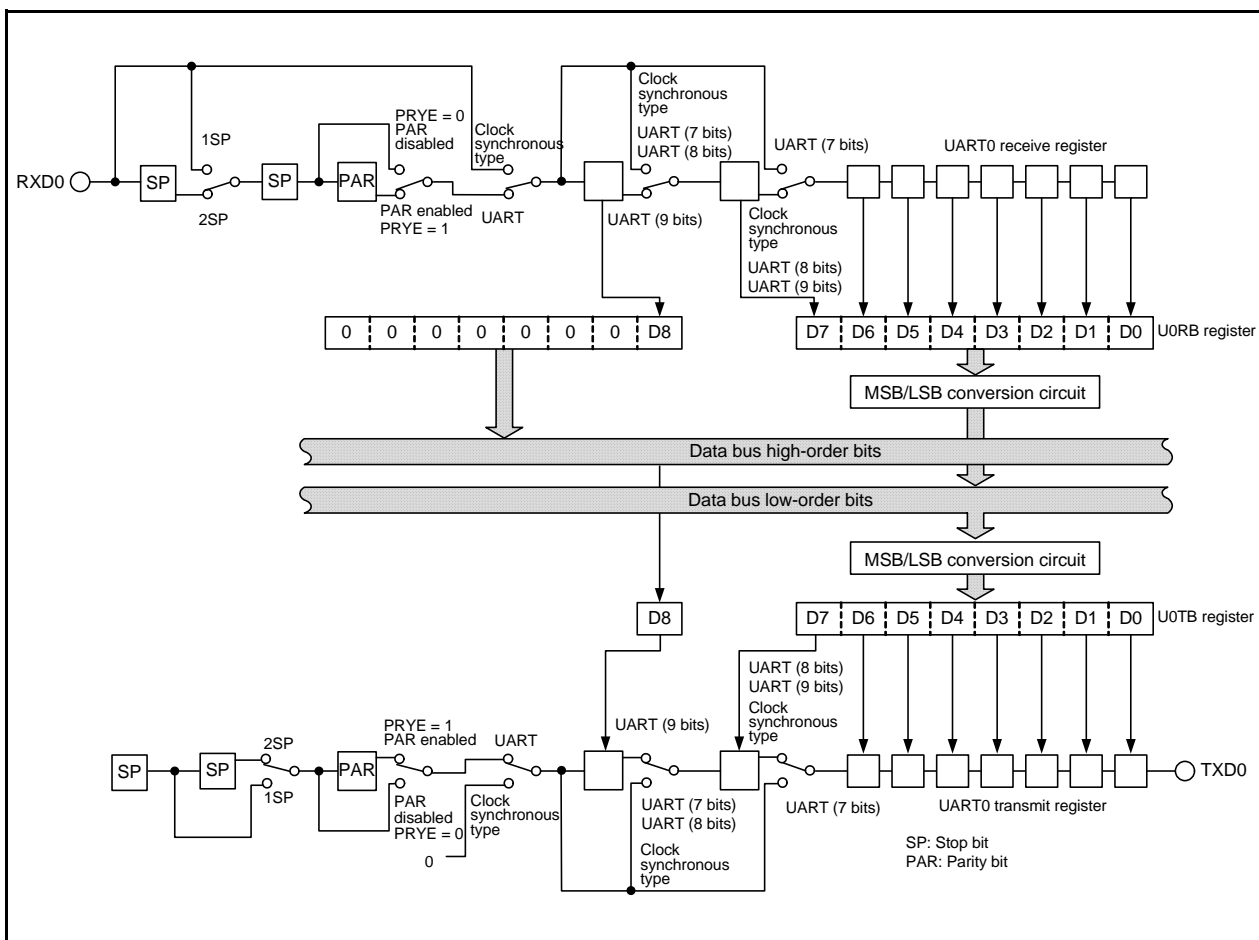

Figure 21.2 Block Diagram of UART0 Transmit/Receive Unit

Table 21.1 Pin Configuration of UART0

Pin Name	Assigned Pin	I/O	Function
TXD0	P1_4	Output	Serial data output
RXD0	P1_5	Input	Serial data input
CLK0	P1_6	I/O	Transfer clock I/O

21.2 Registers

21.2.1 UART0 Transmit/Receive Mode Register (U0MR)

Address 00A0h

Bit	b7	b6	b5	b4	b3	b2	b1	b0
Symbol	—	PRYE	PRY	STPS	CKDIR	SMD2	SMD1	SMD0
After Reset	0	0	0	0	0	0	0	0

Bit	Symbol	Bit Name	Function	R/W
b0	SMD0	Serial I/O mode select bit	b2 b1 b0 0 0 0: Serial interface disabled 0 0 1: Clock synchronous serial I/O mode 1 0 0: UART mode, transfer data 7 bits long 1 0 1: UART mode, transfer data 8 bits long 1 1 0: UART mode, transfer data 9 bits long Other than above: Do not set.	R/W
b1	SMD1			R/W
b2	SMD2			R/W
b3	CKDIR	Internal/external clock select bit	0: Internal clock 1: External clock	R/W
b4	STPS	Stop bit length select bit	0: One stop bit 1: Two stop bits	R/W
b5	PRY	Odd/even parity select bit	Enabled when PRYE = 1 0: Odd parity 1: Even parity	R/W
b6	PRYE	Parity enable bit	0: Parity disabled 1: Parity enabled	R/W
b7	—	Reserved bit	Set to 0.	R/W

21.2.2 UART0 Bit Rate Register (U0BRG)

Address 00A1h

Bit	b7	b6	b5	b4	b3	b2	b1	b0
Symbol	—	—	—	—	—	—	—	—
After Reset	X	X	X	X	X	X	X	X

Bit	Function	Setting Range	R/W
b7 to b0	If the setting value is n, U0BRG divides the count source by n+1.	00h to FFh	W

Write to the U0BRG register while transmission and reception stop.

Use the MOV instruction to write to this register.

Set bits CLK0 and CLK1 in the U0C0 register before writing to the U0BRG register.

21.2.3 UART0 Transmit Buffer Register (U0TB)

Address 00A3h to 00A2h

Bit	b7	b6	b5	b4	b3	b2	b1	b0
Symbol	—	—	—	—	—	—	—	—
After Reset	X	X	X	X	X	X	X	X

Bit	b15	b14	b13	b12	b11	b10	b9	b8
Symbol	—	—	—	—	—	—	—	—
After Reset	X	X	X	X	X	X	X	X

Bit	Symbol	Function	R/W
b0	—	Transmit data	W
b1	—		
b2	—		
b3	—		
b4	—		
b5	—		
b6	—		
b7	—		
b8	—		
b9	—	Nothing is assigned. If necessary, set to 0. When read, the content is undefined.	—
b10	—		
b11	—		
b12	—		
b13	—		
b14	—		
b15	—		

If the transfer data is 9 bits long, write data to the high-order byte first, then low-order byte of the U0TB register.

Use the MOV instruction to write to this register.

21.2.4 UART0 Transmit/Receive Control Register 0 (U0C0)

Address 00A4h

Bit	b7	b6	b5	b4	b3	b2	b1	b0
Symbol	UFORM	CKPOL	NCH	—	TXEPT	—	CLK1	CLK0
After Reset	0	0	0	0	1	0	0	0

Bit	Symbol	Bit Name	Function	R/W
b0	CLK0	BRG count source select bit ⁽¹⁾	b1 b0 0 0: f1 selected 0 1: f8 selected 1 0: f32 selected 1 1: Do not set.	R/W
b1	CLK1			R/W
b2	—	Reserved bit	Set to 0.	R/W
b3	TXEPT	Transmit register empty flag	0: Data present in the transmit register (transmission in progress) 1: No data in the transmit register (transmission completed)	R
b4	—	Nothing is assigned. If necessary, set to 0. When read, the content is 0.		—
b5	NCH	Data output select bit	0: TXD0 pin set to CMOS output 1: TXD0 pin set to N-channel open-drain output	R/W
b6	CKPOL	CLK polarity select bit	0: Transmit data output at the falling edge and receive data input at the rising edge of the transfer clock 1: Transmit data output at the rising edge and receive data input at the falling edge of the transfer clock	R/W
b7	UFORM	Transfer format select bit	0: LSB first 1: MSB first	R/W

Note:

- If the BRG count source is switched, set the U0BRG register again.

21.2.5 UART0 Transmit/Receive Control Register 1 (U0C1)

Address 00A5h

Bit	b7	b6	b5	b4	b3	b2	b1	b0
Symbol	—	—	U0RRM	U0IRS	RI	RE	TI	TE
After Reset	0	0	0	0	0	0	1	0

Bit	Symbol	Bit Name	Function	R/W
b0	TE	Transmit enable bit	0: Transmission disabled 1: Transmission enabled	R/W
b1	TI	Transmit buffer empty flag	0: Data present in the U0TB register 1: No data in the U0TB register	R
b2	RE	Receive enable bit	0: Reception disabled 1: Reception enabled	R/W
b3	RI	Receive complete flag ⁽¹⁾	0: No data in the U0RB register 1: Data present in the U0RB register	R
b4	U0IRS	UART0 transmit interrupt source select bit	0: Transmission buffer empty (TI = 1) 1: Transmission completed (TXEPT = 1)	R/W
b5	U0RRM	UART0 continuous receive mode enable bit ⁽²⁾	0: Continuous receive mode disabled 1: Continuous receive mode enabled	R/W
b6	—	Nothing is assigned. If necessary, set to 0. When read, the content is 0.		—
b7	—			

Notes:

- The RI bit is set to 0 when the higher byte of the U0RB register is read.
- In UART mode, set the U0RRM bit to 0 (continuous receive mode disabled).

21.2.6 UART0 Receive Buffer Register (U0RB)

Address 00A7h to 00A6h

Bit	b7	b6	b5	b4	b3	b2	b1	b0
Symbol	—	—	—	—	—	—	—	—
After Reset	X	X	X	X	X	X	X	X

Bit	b15	b14	b13	b12	b11	b10	b9	b8
Symbol	SUM	PER	FER	OER	—	—	—	—
After Reset	X	X	X	X	X	X	X	X

Bit	Symbol	Bit Name	Function	R/W
b0	—	—	Receive data (D7 to D0)	R
b1	—			
b2	—			
b3	—			
b4	—			
b5	—			
b6	—			
b7	—			
b8	—	—	Receive data (D8)	R
b9	—	Nothing is assigned. If necessary, set to 0. When read, the content is undefined.		—
b10	—			
b11	—			
b12	OER			
b13	FER	Framing error flag ^(1, 2)	0: No framing error 1: Framing error	R
b14	PER	Parity error flag ^(1, 2)	0: No parity error 1: Parity error	R
b15	SUM	Error sum flag ^(1, 2)	0: No error 1: Error	R

Notes:

- Bits SUM, PER, FER, and OER are set to 0 (no error) when either of the following is set:
 - Bits SMD2 to SMD0 in the U0MR register are set to 000b (serial interface disabled), or
 - The RE bit in the U0C1 register is set to 0 (reception disabled)
 The SUM bit is set to 0 (no error) when all of bits PER, FER, and OER are set to 0 (no error).
 Bits PER and FER are also set to 0 when the high-order byte of the U0RB register is read.
 When setting bits SMD2 to SMD0 in the U0MR register to 000b, set the TE bit in the U0C1 register to 0 (transmission disabled) and the RE bit to 0 (reception disabled).
- These error flags are invalid when bits SMD2 to SMD0 in the U0MR register are set to 001b (clock synchronous serial I/O mode). When read, the content is undefined.

Always read the U0RB register in 16-bit units.

21.2.7 UART0 Pin Select Register (U0SR)

Address 0188h

Bit	b7	b6	b5	b4	b3	b2	b1	b0
Symbol	—	—	—	CLK0SELO	—	RXD0SELO	—	TXD0SELO
After Reset	0	0	0	0	0	0	0	0

Bit	Symbol	Bit Name	Function	R/W
b0	TXD0SELO	TXD0 pin select bit	0: TXD0 pin not used 1: P1_4 assigned	R/W
b1	—	Nothing is assigned. If necessary, set to 0. When read, the content is 0.		—
b2	RXD0SELO	RXD0 pin select bit	0: RXD0 pin not used 1: P1_5 assigned	R/W
b3	—	Nothing is assigned. If necessary, set to 0. When read, the content is 0.		—
b4	CLK0SELO	CLK0 pin select bit	0: CLK0 pin not used 1: P1_6 assigned	R/W
b5	—	Nothing is assigned. If necessary, set to 0. When read, the content is 0.		—
b6	—			
b7	—			

The U0SR register selects which pin is assigned to the UART0 I/O. To use the I/O pin for UART0, set this register.

Set the U0SR register before setting the UART0 associated registers. Also, do not change the setting value in this register during UART0 operation.

21.3 Clock Synchronous Serial I/O Mode

In clock synchronous serial I/O mode, data is transmitted and received using a transfer clock.

Table 21.2 lists the Clock Synchronous Serial I/O Mode Specifications. Table 21.3 lists the Registers Used and Settings in Clock Synchronous Serial I/O Mode.

Table 21.2 Clock Synchronous Serial I/O Mode Specifications

Item	Specification
Transfer data format	<ul style="list-style-type: none"> Transfer data length: 8 bits
Transfer clocks	<ul style="list-style-type: none"> The CKDIR bit in the U0MR register is set to 0 (internal clock): $f_i/(2(n+1))$ $f_i = f_1, f_8, f_{32}$ $n =$ setting value in the U0BRG register: 00h to FFh The CKDIR bit is set to 1 (external clock): Input from the CLK0 pin
Transmit start conditions	<ul style="list-style-type: none"> To start transmission, the following requirements must be met: ⁽¹⁾ <ul style="list-style-type: none"> The TE bit in the U0C1 register is set to 1 (transmission enabled). The TI bit in the U0C1 register is set to 0 (data present in the U0TB register).
Receive start conditions	<ul style="list-style-type: none"> To start reception, the following requirements must be met: ⁽¹⁾ <ul style="list-style-type: none"> The RE bit in the U0C1 register is set to 1 (reception enabled). The TE bit in the U0C1 register is set to 1 (transmission enabled). The TI bit in the U0C1 register is set to 0 (data present in the U0TB register).
Interrupt request generation timing	<ul style="list-style-type: none"> For transmission: One of the following can be selected. <ul style="list-style-type: none"> The U0IRS bit is set to 0 (transmit buffer empty): When data is transferred from the U0TB register to the UART0 transmit register (at start of transmission). The U0IRS bit is set to 1 (transmission completed): When data transmission from the UART0 transmit register is completed. For reception: When data is transferred from the UART0 receive register to the U0RB register (at completion of reception).
Error detection	<ul style="list-style-type: none"> Overrun error ⁽²⁾ This error occurs if the serial interface starts receiving the next unit of data before reading the U0RB register and receives the 7th bit of the next unit of data.
Selectable functions	<ul style="list-style-type: none"> CLK polarity selection Transfer data input/output can be selected to occur synchronously with the rising or the falling edge of the transfer clock. LSB first, MSB first selection Whether transmitting or receiving data begins with bit 0 or begins with bit 7 can be selected. Continuous receive mode selection Reception is enabled immediately by reading the U0RB register.

Notes:

- When an external clock is selected, the requirements must be met in either of the following states:
 - The external clock is held high when the CKPOL bit in the U0C0 register is set to 0 (transmit data output at the falling edge and receive data input at the rising edge of the transfer clock)
 - The external clock is held low when the CKPOL bit in the U0C0 register is set to 1 (transmit data output at the rising edge and receive data input at the falling edge of the transfer clock)
- If an overrun error occurs, the receive data (b0 to b8) in the U0RB register will be undefined. The IR bit in the S0RIC register remains unchanged.

Table 21.3 Registers Used and Settings in Clock Synchronous Serial I/O Mode⁽¹⁾

Register	Bit	Function
U0TB	b0 to b7	Set data transmission.
U0RB	b0 to b7	Receive data can be read.
	OER	Overrun error flag
U0BRG	b0 to b7	Set a bit rate.
U0MR	SMD2 to SMD0	Set to 001b.
	CKDIR	Select the internal clock or external clock.
U0C0	CLK1, CLK0	Select the count source for the U0BRG register.
	TXEPT	Transmit register empty flag
	NCH	Select TXD0 pin output mode.
	CKPOL	Select the transfer clock polarity.
	UFORM	Select LSB first or MSB first.
U0C1	TE	Set to 1 to enable transmission/reception
	TI	Transmit buffer empty flag
	RE	Set to 1 to enable reception.
	RI	Receive complete flag
	U0IRS	Select the UART0 transmit interrupt source.
	U0RRM	Set to 1 to use continuous receive mode.

Note:

1. Set the bits not listed in this table to 0 when writing to the above registers in clock synchronous serial I/O mode.

Table 21.4 lists the I/O Pin Functions in Clock Synchronous Serial I/O Mode.

After UART0 operating mode is selected, the TXD0 pin outputs a “H” level until transfer starts. (If the NCH bit is set to 1 (N-channel open-drain output), this pin is in the high-impedance state.)

Table 21.4 I/O Pin Functions in Clock Synchronous Serial I/O Mode

Pin Name	Function	Selection Method
TXD0 (P1_4)	Serial data output	TXD0SEL0 bit in U0SR register = 1 For reception only: P1_4 can be used as a port by setting TXD0SEL0 bit = 0.
RXD0 (P1_5)	Serial data input	RXD0SEL0 bit in U0SR register = 1 PD1_5 bit in PD1 register = 0 For transmission only: P1_5 can be used as a port by setting RXD0SEL0 bit = 0.
CLK0 (P1_6)	Transfer clock output	CLK0SEL0 bit in U0SR register = 1 CKDIR bit in U0MR register = 0
	Transfer clock input	CLK0SEL0 bit in U0SR register = 1 CKDIR bit in U0MR register = 1 PD1_6 bit in PD1 register = 0

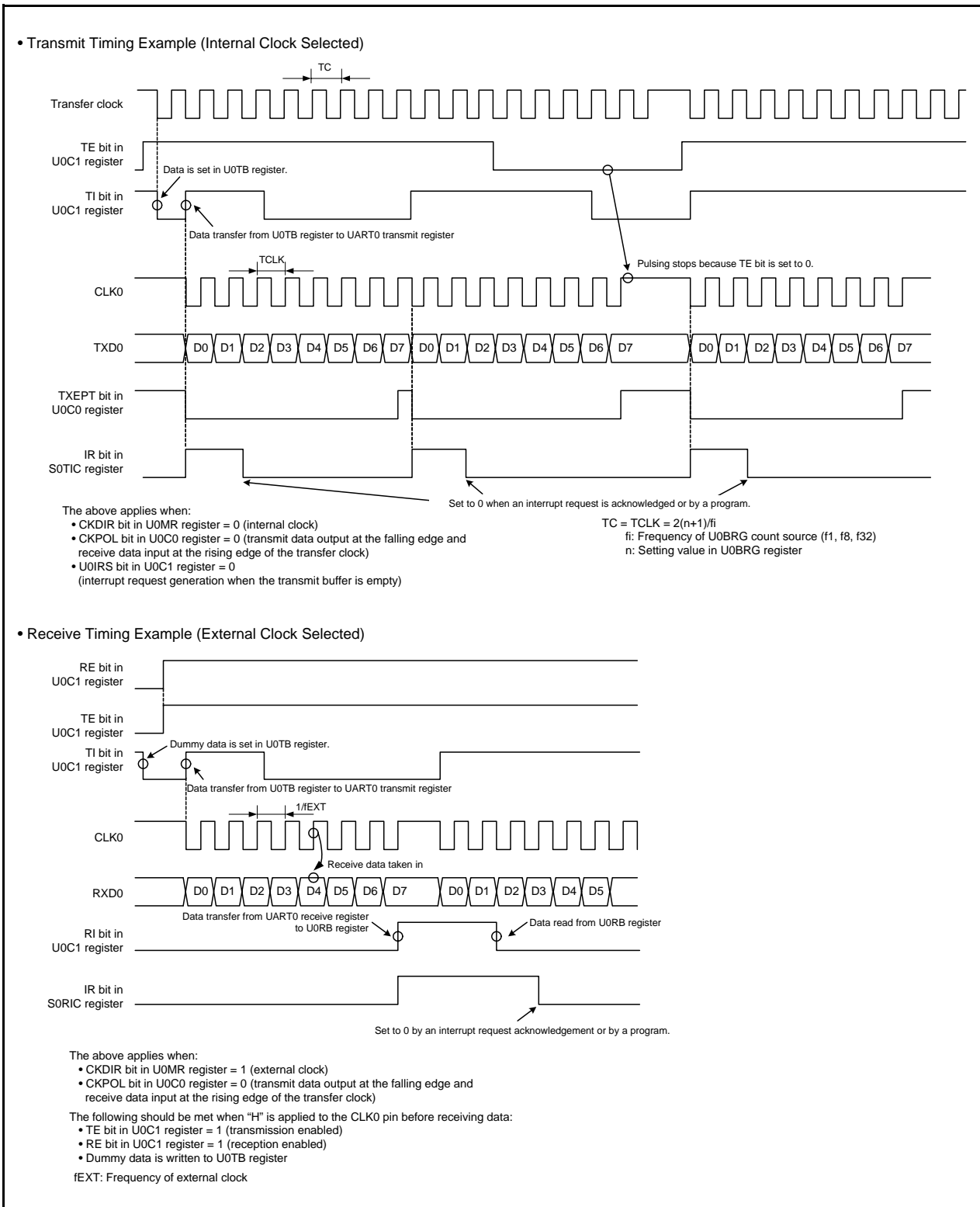

Figure 21.3 Transmit and Receive Timing in Clock Synchronous Serial I/O Mode

21.3.1 Measure for Dealing with Communication Errors

If communication is aborted or a communication error occurs while transmitting or receiving in clock synchronous serial I/O mode, follow the procedures below:

- (1) Set the TE bit in the U0C1 register to 0 (transmission disabled) and the RE bit to 0 (reception disabled).
- (2) Set bits SMD2 to SMD0 in the U0MR register to 000b (serial interface disabled).
- (3) Set bits SMD2 to SMD0 in the U0MR register to 001b (clock synchronous serial I/O mode).
- (4) Set the TE bit in the U0C1 register to 1 (transmission enabled) and the RE bit to 1 (reception enabled).

21.3.2 Polarity Select Function

Figure 21.4 shows the Transfer Clock Polarity. Use the CKPOL bit in the U0C0 register to select the transfer clock polarity.

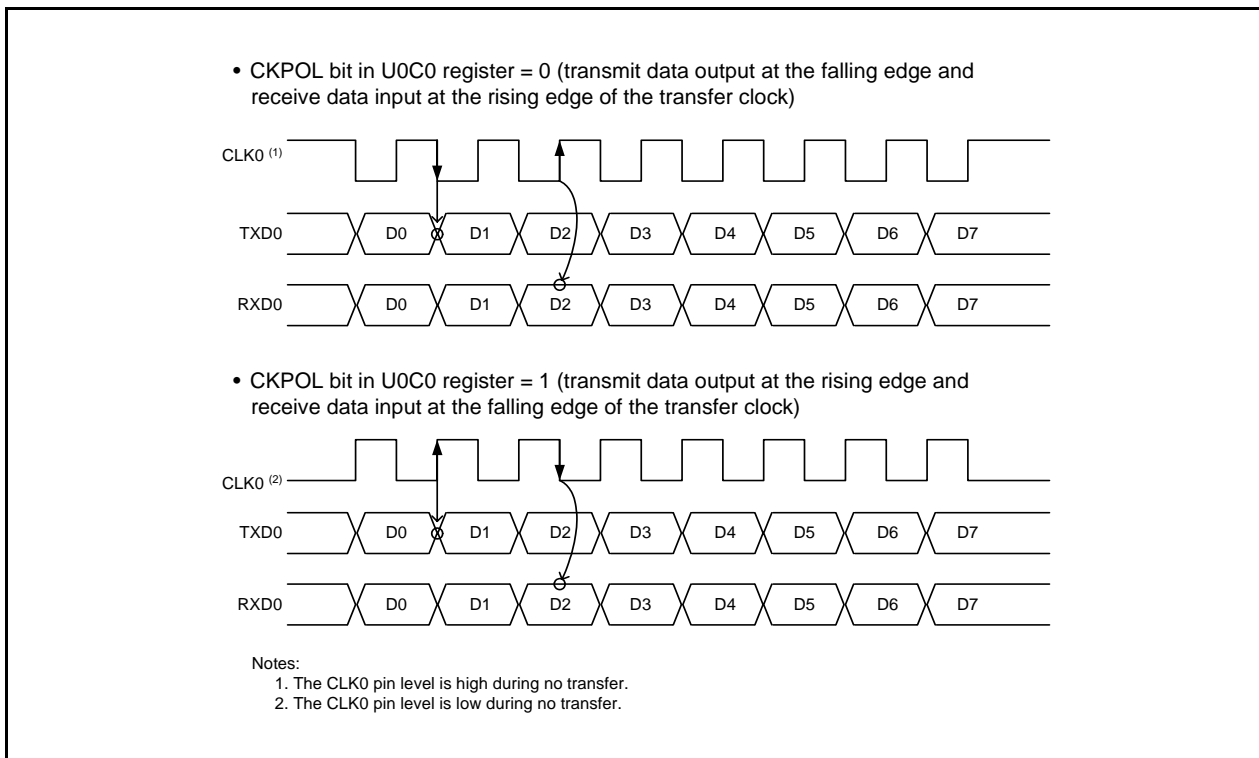

Figure 21.4 Transfer Clock Polarity

21.3.3 LSB First/MSB First Select Function

Figure 21.5 shows the Transfer Format. Use the UFORM bit in the U0C0 register to select the transfer format.

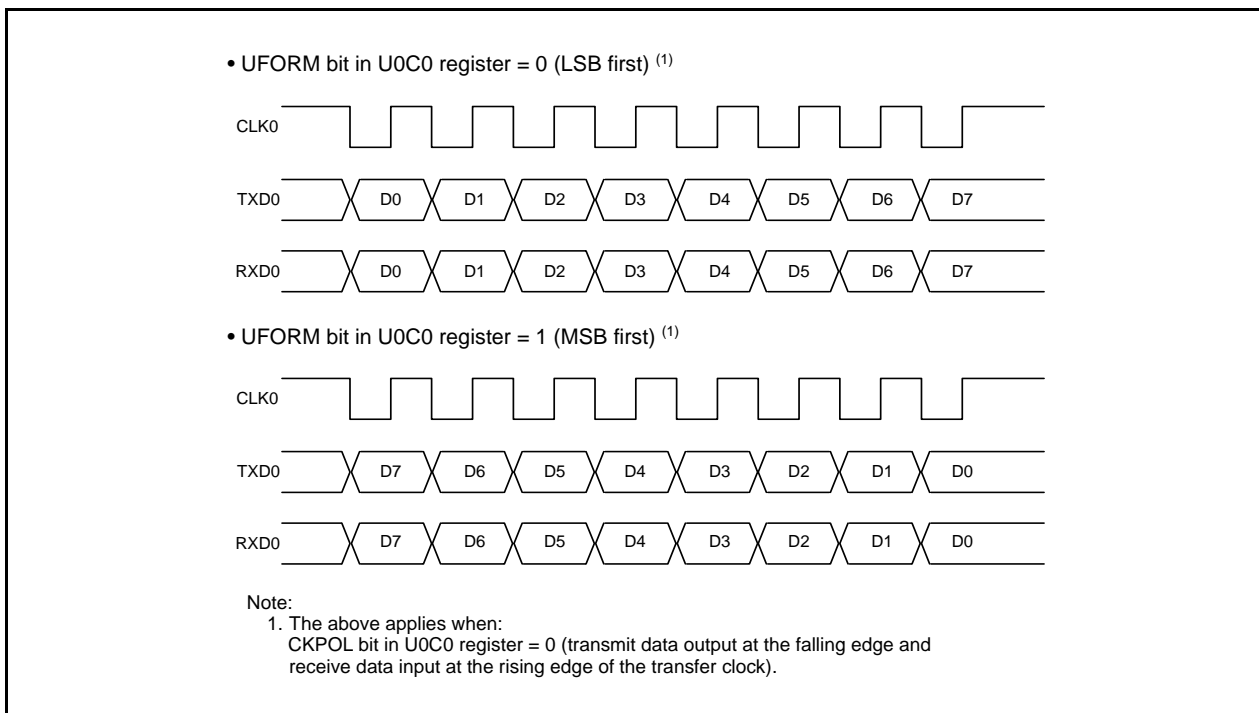

Figure 21.5 Transfer Format

21.3.4 Continuous Receive Mode

Continuous receive mode is selected by setting the UORRM bit in the U0C1 register to 1 (continuous receive mode enabled). In this mode, reading the U0RB register sets the TI bit in the U0C1 register to 0 (data present in the U0TB register). If the UORRM bit is set to 1, do not write dummy data to the U0TB register by a program.

21.4 Clock Asynchronous Serial I/O (UART) Mode

The UART mode allows data transmission and reception after setting the desired bit rate and transfer data format. Table 21.5 lists the UART Mode Specifications. Table 21.6 lists the Registers Used and Settings in UART Mode.

Table 21.5 UART Mode Specifications

Item	Specification
Transfer data formats	<ul style="list-style-type: none"> • Character bits (transfer data): Selectable among 7, 8 or 9 bits • Start bit: 1 bit • Parity bit: Selectable among odd, even, or none • Stop bits: Selectable among 1 or 2 bits
Transfer clocks	<ul style="list-style-type: none"> • The CKDIR bit in the U0MR register is set to 0 (internal clock): $f_j/(16(n+1))$ $f_j = f_1, f_8, f_{32}$ $n =$ setting value in the U0BRG register: 00h to FFh • The CKDIR bit is set to 1 (external clock): $f_{EXT}/(16(n+1))$ f_{EXT}: Input from the CLK0 pin, $n =$ setting value in the U0BRG register: 00h to FFh
Transmit start conditions	<ul style="list-style-type: none"> • To start transmission, the following requirements must be met: <ul style="list-style-type: none"> - The TE bit in the U0C1 register is set to 1 (transmission enabled). - The TI bit in the U0C1 register is set to 0 (data present in the U0TB register).
Receive start conditions	<ul style="list-style-type: none"> • To start reception, the following requirements must be met: <ul style="list-style-type: none"> - The RE bit in the U0C1 register is set to 1 (reception enabled). - Start bit detection
Interrupt request generation timing	<ul style="list-style-type: none"> • For transmission: One of the following can be selected. <ul style="list-style-type: none"> - The U0IRS bit is set to 0 (transmit buffer empty): When data is transferred from the U0TB register to the UART0 transmit register (at start of transmission). - The U0IRS bit is set to 1 (transfer completed): When data transmission from the UART0 transmit register is completed. • For reception: When data is transferred from the UART0 receive register to the U0RB register (at completion of reception).
Error detection	<ul style="list-style-type: none"> • Overrun error ⁽¹⁾ This error occurs if the serial interface starts receiving the next unit of data before reading the U0RB register and receive the bit one before the last stop bit of the next unit of data. • Framing error This error occurs when the set number of stop bits is not detected. ⁽²⁾ • Parity error This error occurs when parity is enabled, and the number of 1's in the parity and character bits do not match the set number of 1's. ⁽²⁾ • Error sum flag This flag is set to 1 if an overrun, framing, or parity error occurs.

Notes:

1. If an overrun error occurs, the receive data (b0 to b8) in the U0RB register will be undefined.
2. The framing error flag and the parity error flag are set to 1 when data is transferred from the UART0 receive register to the U0RB register.

Table 21.6 Registers Used and Settings in UART Mode

Register	Bit	Function
U0TB	b0 to b8	Set transmit data. ⁽¹⁾
U0RB	b0 to b8	Receive data can be read. ⁽²⁾
	OER,FER,PER,SUM	Error flag
U0BRG	b0 to b7	Set a bit rate.
U0MR	SMD2 to SMD0	Set to 100b when transfer data is 7 bits long. Set to 101b when transfer data is 8 bits long. Set to 110b when transfer data is 9 bits long.
	CKDIR	Select the internal clock or external clock.
	STPS	Select the stop bit.
	PRY, PRYE	Select whether parity is included and whether odd or even.
U0C0	CLK0, CLK1	Select the count source for the U0BRG register.
	TXEPT	Transmit register empty flag
	NCH	Select TXD0 pin output mode.
	CKPOL	Set to 0.
	UFORM	Select LSB first or MSB first when transfer data is 8 bits long. Set to 0 when transfer data is 7 bits or 9 bits long.
U0C1	TE	Set to 1 to enable transmission.
	TI	Transmit buffer empty flag
	RE	Set to 1 to enable reception.
	RI	Receive complete flag
	U0IRS	Select the UART0 transmit interrupt source.
	U0RRM	Set to 0.

Notes:

- The bits used for transmission/receive data are as follows:
 - Bits b0 to b6 when transfer data is 7 bits long
 - Bits b0 to b7 when transfer data is 8 bits long
 - Bits b0 to b8 when transfer data is 9 bits long
- The contents of the following are undefined:
 - Bits 7 and 8 when the transfer data is 7 bits long
 - Bit 8 when the transfer data is 8 bits long

Table 21.7 lists the I/O Pin Functions in UART Mode.

After the UART0 operating mode is selected, the TXD0 pin outputs a “H” level until transfer starts. (If the NCH bit is set to 1 (N-channel open-drain output), this pin is in the high-impedance state.)

Table 21.7 I/O Pin Functions in UART Mode

Pin name	Function	Selection Method
TXD0 (P1_4)	Serial data output	TXD0SEL0 bit in U0SR register = 1 For reception only: P1_4 can be used as a port by setting TXD0SEL0 bit = 0.
RXD0 (P1_5)	Serial data input	RXD0SEL0 bit in U0SR register = 1 PD1_5 bit in PD1 register = 0 For transmission only: P1_5 can be used as a port by setting RXD0SEL0 bit = 0.
CLK0 (P1_6)	Programmable I/O port	CLK0SEL0 bit in U0SR register = 0 (CLK0 pin not used)
	Transfer clock input	CLK0SEL0 bit in U0SR register = 1 CKDIR bit in U0MR register = 1 PD1_6 bit in PD1 register = 0

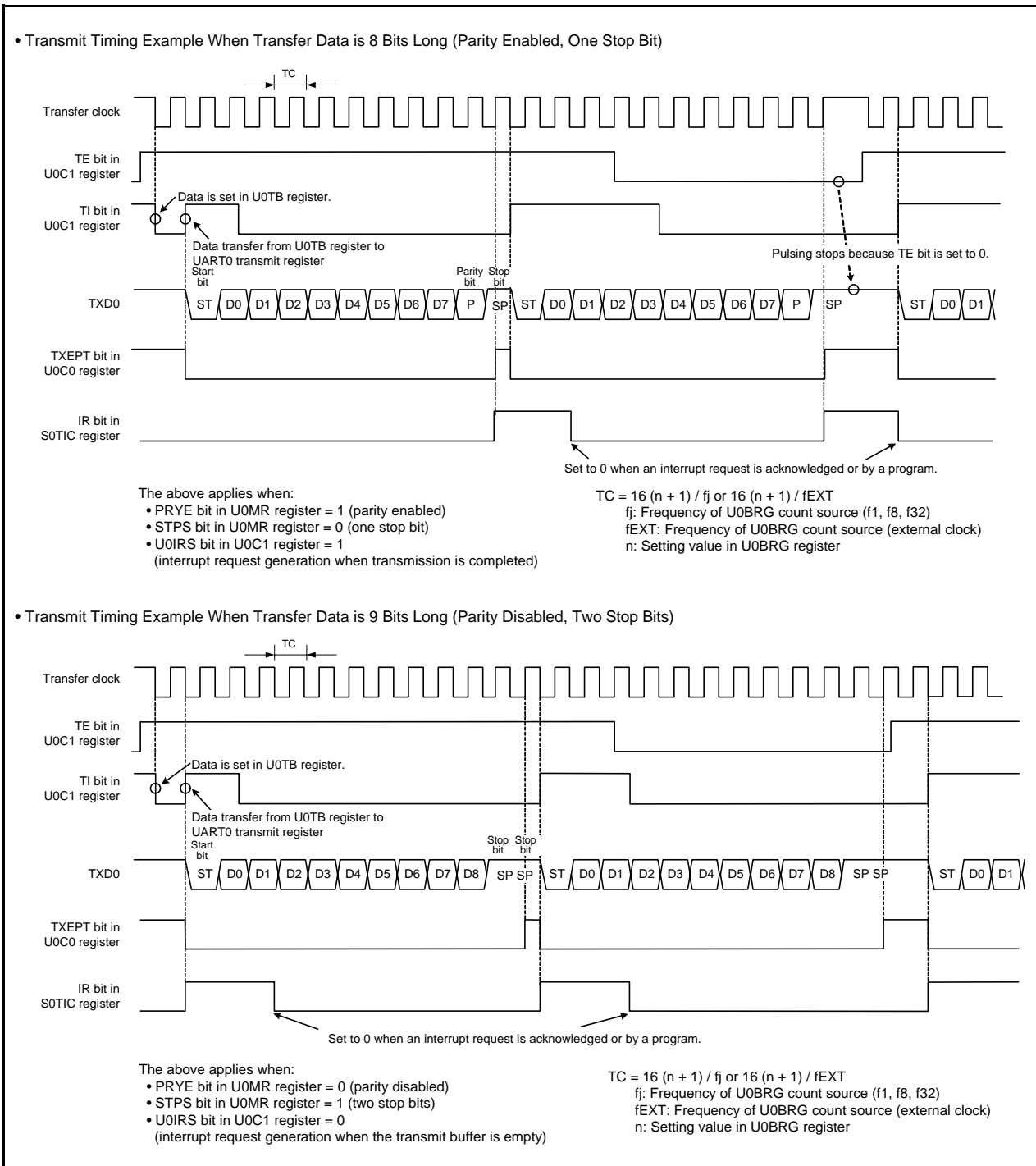

Figure 21.6 Transmit Timing in UART Mode

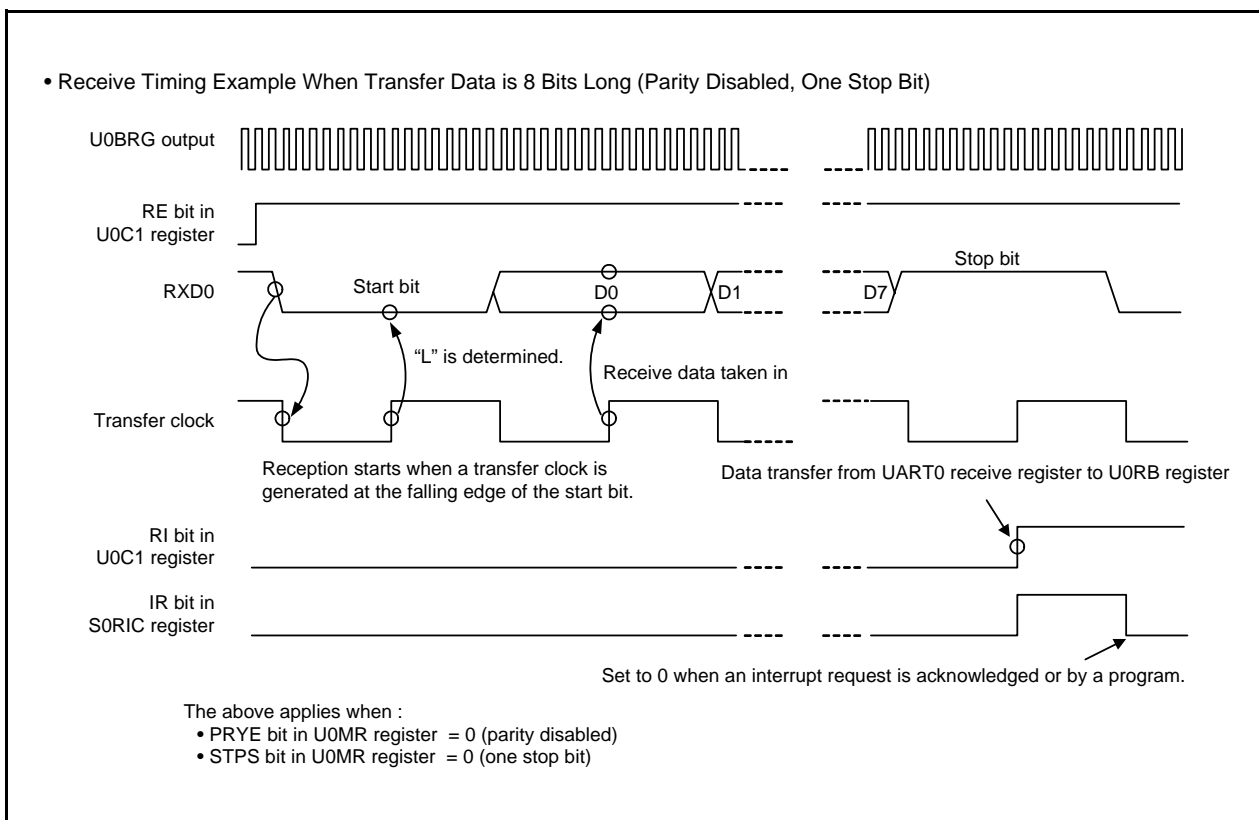

Figure 21.7 Receive Timing in UART Mode

21.4.1 Bit Rate

In UART mode, the bit rate is the frequency divided by the U0BRG register and divided by 16.

UART mode	
• Internal clock selected	
$\text{Setting value in U0BRG register} = \frac{f_j}{\text{Bit Rate} \times 16} - 1$	
f _j : Count source frequency of U0BRG register (f ₁ , f ₈ , or f ₃₂)	
• External clock selected	
$\text{Setting value in U0BRG register} = \frac{f_{\text{EXT}}}{\text{Bit Rate} \times 16} - 1$	
f _{EXT} : Count source frequency of U0BRG register (external clock)	

Figure 21.8 Formula for Calculating Setting Value in U0BRG Register

Table 21.8 Bit Rate Setting Example in UART Mode (Internal Clock Selected)

Bit Rate (bps)	U0BRG Count Source	System Clock = 20 MHz			System Clock = 18.432 MHz ⁽¹⁾			System Clock = 8 MHz		
		U0BRG Setting Value	Actual Time (bps)	Setting Error (%)	U0BRG Setting Value	Actual Time (bps)	Setting Error (%)	U0BRG Setting Value	Actual Time (bps)	Setting Error (%)
1200	f8	129 (81h)	1201.92	0.16	119 (77h)	1200.00	0.00	51 (33h)	1201.92	0.16
2400	f8	64 (40h)	2403.85	0.16	59 (3Bh)	2400.00	0.00	25 (19h)	2403.85	0.16
4800	f8	32 (20h)	4734.85	-1.36	29 (1Dh)	4800.00	0.00	12 (0Ch)	4807.69	0.16
9600	f1	129 (81h)	9615.38	0.16	119 (77h)	9600.00	0.00	51 (33h)	9615.38	0.16
14400	f1	86 (56h)	14367.82	-0.22	79 (4Fh)	14400.00	0.00	34 (22h)	14285.71	-0.79
19200	f1	64 (40h)	19230.77	0.16	59 (3Bh)	19200.00	0.00	25 (19h)	19230.77	0.16
28800	f1	42 (2Ah)	29069.77	0.94	39 (27h)	28800.00	0.00	16 (10h)	29411.76	2.12
38400	f1	32 (20h)	37878.79	-1.36	29 (1Dh)	38400.00	0.00	12 (0Ch)	38461.54	0.16
57600	f1	21 (15h)	56818.18	-1.36	19 (13h)	57600.00	0.00	8 (08h)	55555.56	-3.55
115200	f1	10 (0Ah)	113636.36	-1.36	9 (09h)	115200.00	0.00	–	–	–

Note:

- For the high-speed on-chip oscillator, the correction value in the FRA4 register should be written into the FRA1 register and the correction value in the FRA5 register should be written into the FRA3 register. This applies when the high-speed on-chip oscillator is selected as the system clock and bits FRA22 to FRA20 in the FRA2 register are set to 000b (divide-by-2 mode). For the precision of the high-speed on-chip oscillator, refer to **30. Electrical Characteristics**.

21.4.2 Measure for Dealing with Communication Errors

If communication is aborted or a communication error occurs while transmitting or receiving in clock synchronous serial I/O mode, follow the procedures below:

- (1) Set the TE bit in the U0C1 register to 0 (transmission disabled) and the RE bit to 0 (reception disabled).
- (2) Set bits SMD2 to SMD0 in the U0MR register to 000b (serial interface disabled).
- (3) Set bits SMD2 to SMD0 in the U0MR register to 001b (clock synchronous serial I/O mode).
- (4) Set the TE bit in the U0C1 register to 1 (transmission enabled) and the RE bit to 1 (reception enabled).

21.5 Notes on Serial Interface (UART0)

- When reading data from the UORB register either in clock synchronous serial I/O mode or in clock asynchronous serial I/O mode, always read data in 16-bit units.

When the high-order byte of the UORB register is read, bits PER and FER in the UORB register and the RI bit in the UOC1 register are set to 0.

To check receive errors, read the UORB register and then use the read data.

Program example to read the receive buffer register:

```
MOV.W    00A6H,R0    ; Read the UORB register
```

- When writing data to the UOTB register in clock asynchronous serial I/O mode with 9-bit transfer data length, write data to the high-order byte first and then the low-order byte, in 8-bit units.

Program example to write to the transmit buffer register:

```
MOV.B    #XXH,00A3H  ; Write to the high-order byte of the UOTB register
```

```
MOV.B    #XXH,00A2H  ; Write to the low-order byte of the UOTB register
```

22. Serial Interface (UART2)

The serial interface consists of two channels, UART0 to UART2. This chapter describes the UART2.

22.1 Overview

UART2 has a dedicated timer to generate a transfer clock.

Figure 22.1 shows a UART2 Block Diagram. Figure 22.2 shows a Block Diagram of UART2 Transmit/Receive Unit. Table 22.1 lists the Pin Configuration of UART2.

UART2 has the following modes:

- Clock synchronous serial I/O mode
- Clock asynchronous serial I/O mode (UART mode)
- Special mode 1 (I²C mode)
- Serial mode 3 (bus collision detection function, IE mode)
- Multiprocessor communication function

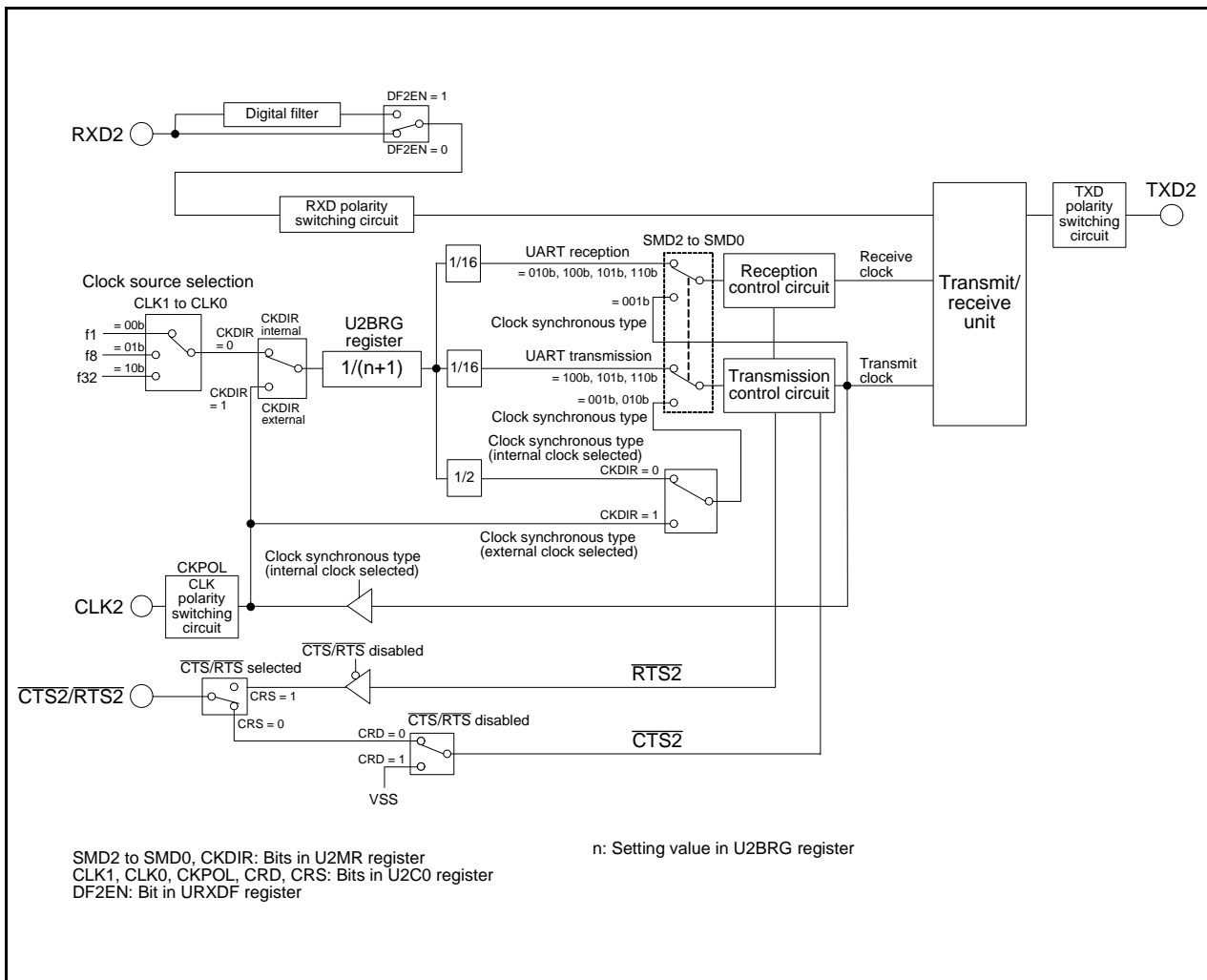

Figure 22.1 UART2 Block Diagram

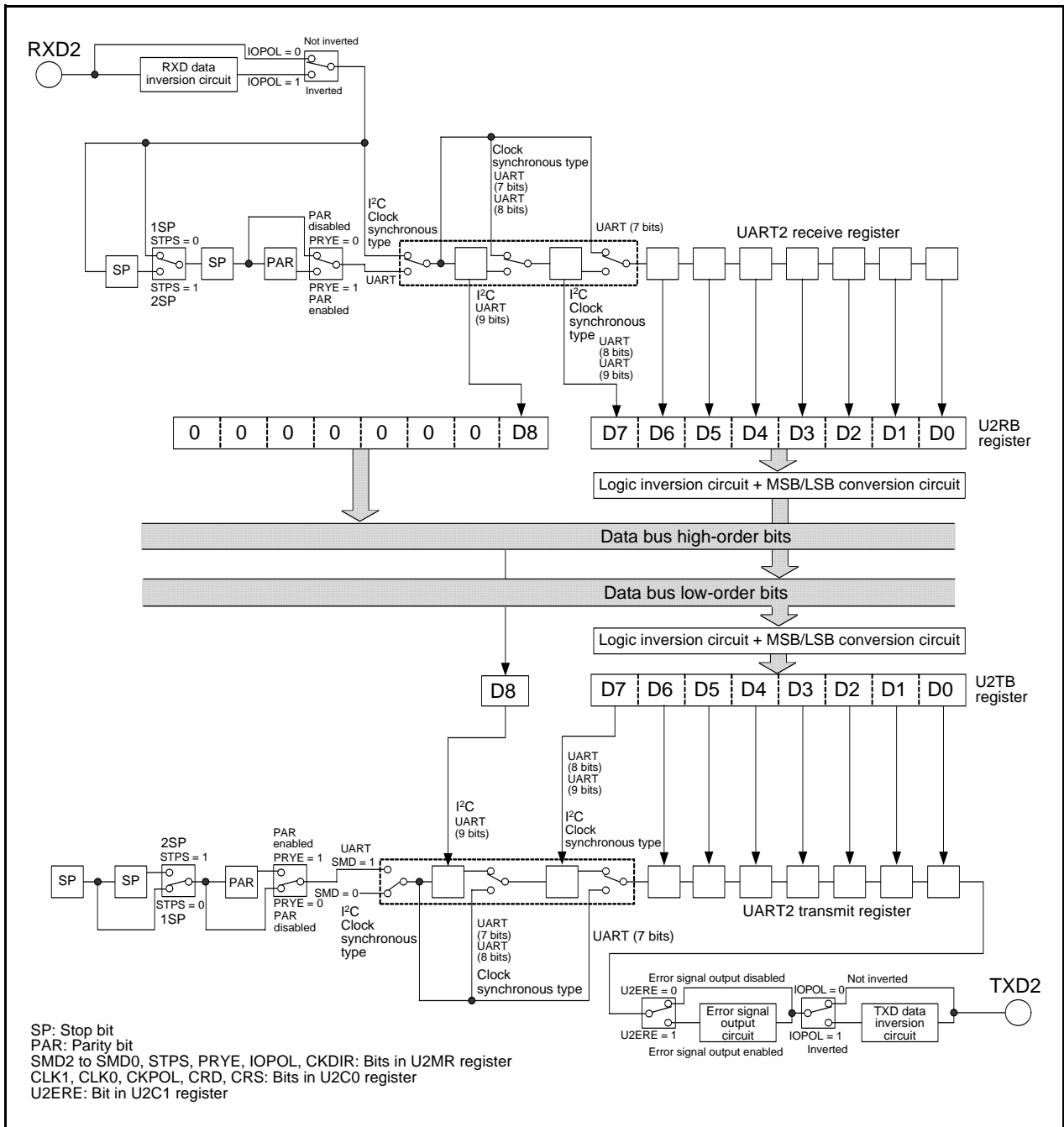

Figure 22.2 Block Diagram of UART2 Transmit/Receive Unit

Table 22.1 Pin Configuration of UART2

Pin Name	Assigned Pin	I/O	Function
TXD2	P0_0, P3_6, or P3_7	Output	Serial data output
RXD2	P3_6, P3_7, or P4_5	Input	Serial data input
CLK2	P0_5 or P3_5	I/O	Transfer clock I/O
CTS2	P3_3	Input	Transmit control input
RTS2	P3_3	Output	Receive control input
SCL2	P3_6, P3_7, or P4_5	I/O	I2C mode clock I/O
SDA2	P0_0, P3_6, or P3_7	I/O	I2C mode data I/O

22.2 Registers

22.2.1 UART2 Transmit/Receive Mode Register (U2MR)

Address 00A8h

Bit	b7	b6	b5	b4	b3	b2	b1	b0
Symbol	IOPOL	PRYE	PRY	STPS	CKDIR	SMD2	SMD1	SMD0
After Reset	0	0	0	0	0	0	0	0

Bit	Symbol	Bit Name	Function	R/W
b0	SMD0	Serial I/O mode select bit	b2 b1 b0 0 0 0: Serial interface disabled 0 0 1: Clock synchronous serial I/O mode 0 1 0: I ² C mode 1 0 0: UART mode, transfer data 7 bits long 1 0 1: UART mode, transfer data 8 bits long 1 1 0: UART mode, transfer data 9 bits long Other than above: Do not set.	R/W
b1	SMD1			R/W
b2	SMD2			R/W
b3	CKDIR	Internal/external clock select bit	0: Internal clock 1: External clock	R/W
b4	STPS	Stop bit length select bit	0: One stop bit 1: Two stop bits	R/W
b5	PRY	Odd/even parity select bit	Enabled when PRYE = 1 0: Odd parity 1: Even parity	R/W
b6	PRYE	Parity enable bit	0: Parity disabled 1: Parity enabled	R/W
b7	IOPOL	TXD, RXD I/O polarity switch bit	0: Not inverted 1: Inverted	R/W

22.2.2 UART2 Bit Rate Register (U2BRG)

Address 00A9h

Bit	b7	b6	b5	b4	b3	b2	b1	b0
Symbol	—	—	—	—	—	—	—	—
After Reset	X	X	X	X	X	X	X	X

Bit	Function	Setting Range	R/W
b7 to b0	If the setting value is n, U2BRG divides the count source by n+1.	00h to FFh	W

Write to the U2BRG register while transmission and reception stop.

Use the MOV instruction to write to this register.

Set bits CLK1 to CLK0 in the U2C0 register before writing to the U2BRG register.

Immediately after writing 00h to the U2BRG register, there may be a delay of up to 256 cycles of the count source when the following data transmission/reception starts (including the timing when the TI bit in the U2C1 register is set to 0 (data present in the U2TB register)) and when the start bit is detected during reception).

22.2.3 UART2 Transmit Buffer Register (U2TB)

Address 00ABh to 00AAh

Bit	b7	b6	b5	b4	b3	b2	b1	b0
Symbol	—	—	—	—	—	—	—	—
After Reset	X	X	X	X	X	X	X	X

Bit	b15	b14	b13	b12	b11	b10	b9	b8
Symbol	—	—	—	—	—	—	—	MPTB
After Reset	X	X	X	X	X	X	X	X

Bit	Symbol	Function	R/W
b0	—	Transmit data (D7 to D0)	W
b1	—		
b2	—		
b3	—		
b4	—		
b5	—		
b6	—		
b7	—		
b8	MPTB	[When the multiprocessor communication function is not used] (2) Transmit data (D8) [When the multiprocessor communication function is used] (1) • To transfer an ID, set the MPTB bit to 1. • To transfer data, set the MPTB bit to 0.	W
b9	—	Nothing is assigned. If necessary, set to 0. When read, the content is 0.	—
b10	—		
b11	—		
b12	—		
b13	—		
b14	—		
b15	—		

Notes:

- Write to this register in 8-bit units using the MOV instruction. Set bits b0 to b7 after setting the MPTB bit.
- Write to this register using the MOV instruction. When the transfer data length is 9 bits, write in 16-bit units or write to the higher byte first and then the lower byte in 8-bit units.

22.2.4 UART2 Transmit/Receive Control Register 0 (U2C0)

Address 00ACh

Bit	b7	b6	b5	b4	b3	b2	b1	b0
Symbol	UFORM	CKPOL	NCH	CRD	TXEPT	CRS	CLK1	CLK0
After Reset	0	0	0	0	1	0	0	0

Bit	Symbol	Bit Name	Function	R/W
b0	CLK0	U2BRG count source select bit ⁽¹⁾	b1 b0 0 0: f1 selected 0 1: f8 selected 1 0: f32 selected 1 1: Do not set.	R/W
b1	CLK1			R/W
b2	CRS	CTS/RTS function select bit	Enabled when CRD = 0 0: CTS function selected 1: RTS function selected	R/W
b3	TXEPT	Transmit register empty flag	0: Data present in the transmit register (transmission in progress) 1: No data in the transmit register (transmission completed)	R
b4	CRD	CTS/RTS disable bit	0: CTS/RTS function enabled 1: CTS/RTS function disabled	R/W
b5	NCH	Data output select bit	0: Pins TXD2/SDA2, SCL2 set to CMOS output 1: Pins TXD2/SDA2, SCL2 set to N-channel open-drain output	R/W
b6	CKPOL	CLK polarity select bit	0: Transmit data output at the falling edge and receive data input at the rising edge of the transfer clock 1: Transmit data output at the rising edge and receive data input at the falling edge of the transfer clock	R/W
b7	UFORM	Transfer format select bit ⁽²⁾	0: LSB first 1: MSB first	R/W

Notes:

- If bits CLK1 to CLK0 are switched, set the U2BRG register again.
- The UFORM bit is enabled when bits SMD2 to SMD0 in the U2MR register are set to 001b (clock synchronous serial I/O mode), or set to 101b (UART mode, transfer data 8 bits long).
Set the UFORM bit to 1 when bits SMD2 to SMD0 are set to 010b (I²C mode), and to 0 when bits SMD2 to SMD0 are set to 100b (UART mode, transfer data 7 bits long) or 110b (UART mode, transfer data 9 bits long).

22.2.5 UART2 Transmit/Receive Control Register 1 (U2C1)

Address 00ADh

Bit	b7	b6	b5	b4	b3	b2	b1	b0
Symbol	U2ERE	U2LCH	U2RRM	U2IRS	RI	RE	TI	TE
After Reset	0	0	0	0	0	0	1	0

Bit	Symbol	Bit Name	Function	R/W
b0	TE	Transmit enable bit	0: Transmission disabled 1: Transmission enabled	R/W
b1	TI	Transmit buffer empty flag	0: Data present in the U2TB register 1: No data in the U2TB register	R
b2	RE	Receive enable bit	0: Reception disabled 1: Reception enabled	R/W
b3	RI	Receive complete flag	0: No data in the U2RB register 1: Data present in the U2RB register	R
b4	U2IRS	UART2 transmit interrupt source select bit	0: Transmit buffer empty (TI = 1) 1: Transmission completed (TXEPT = 1)	R/W
b5	U2RRM	UART2 continuous receive mode enable bit	0: Continuous receive mode disabled 1: Continuous receive mode enabled	R/W
b6	U2LCH	Data logic select bit ⁽¹⁾	0: Not inverted 1: Inverted	R/W
b7	U2ERE	Error signal output enable bit	0: Output disabled 1: Output enabled	R/W

Note:

- The U2LCH bit is enabled when bits SMD2 to SMD0 in the U2MR register are set to 001b (clock synchronous serial I/O mode), 100b (UART mode, transfer data 7 bits long), or 101b (UART mode, transfer data 8 bits long). Set the U2LCH bit to 0 when bits SMD2 to SMD0 are set to 010b (I²C mode) or 110b (UART mode, transfer data 9 bits long).

22.2.6 UART2 Receive Buffer Register (U2RB)

Address 00AFh to 00AEh

Bit	b7	b6	b5	b4	b3	b2	b1	b0
Symbol	—	—	—	—	—	—	—	—
After Reset	X	X	X	X	X	X	X	X

Bit	b15	b14	b13	b12	b11	b10	b9	b8
Symbol	SUM	PER	FER	OER	—	—	—	MPRB
After Reset	X	X	X	X	X	X	X	X

Bit	Symbol	Bit Name	Function	R/W
b0	—	—	Receive data (D7 to D0)	R
b1	—			
b2	—			
b3	—			
b4	—			
b5	—			
b6	—			
b7	—			
b8	MPRB	—	Receive data (D8) ⁽¹⁾ [When the multiprocessor communication function is not used] Receive data (D8) [When the multiprocessor communication function is used] • When the MPRB bit is set to 0, received D0 to D7 are data fields. • When the MPRB bit is set to 1, received D0 to D7 are ID fields.	R
b9	—	Nothing is assigned. If necessary, set to 0. When read, the content is undefined.		—
b10	—			—
b11	—	Reserved bit	Set to 0.	R/W
b12	OER	Overrun error flag ⁽¹⁾	0: No overrun error 1: Overrun error	R
b13	FER	Framing error flag ^(1, 2)	0: No framing error 1: Framing error	R
b14	PER	Parity error flag ^(1, 2)	0: No parity error 1: Parity error	R
b15	SUM	Error sum flag ^(1, 2)	0: No error 1: Error	R

Notes:

- When bits SMD2 to SMD0 in the U2MR register are set to 000b (serial interface disabled) or the RE bit in the U2C1 register is set to 0 (reception disabled), all of bits SUM, PER, FER, and OER are set to 0 (no error). The SUM bit is set to 0 (no error) when all of bits PER, FER, and OER are set to 0 (no error). Bits PER and FER are set to 0 by reading the lower byte of the U2RB register.
When setting bits SMD2 to SMD0 in the U2MR register to 000b, set the TE bit in the U2C1 register to 0 (transmission disabled) and the RE bit to 0 (reception disabled).
- These error flags are disabled when bits SMD2 to SMD0 in the U2MR register are set to 001b (clock synchronous serial I/O mode) or to 010b (I²C mode). When read, the content is undefined.

22.2.7 UART2 Digital Filter Function Select Register (URXDF)

Address 00B0h

Bit	b7	b6	b5	b4	b3	b2	b1	b0
Symbol	—	—	—	—	—	DF2EN	—	—
After Reset	0	0	0	0	0	0	0	0

Bit	Symbol	Bit Name	Function	R/W
b0	—	Nothing is assigned. If necessary, set to 0. When read, the content is 0.		—
b1	—			
b2	DF2EN	RXD2 digital filter enable bit ⁽¹⁾	0: RXD2 digital filter disabled 1: RXD2 digital filter enabled	R/W
b3	—	Nothing is assigned. If necessary, set to 0. When read, the content is 0.		—
b4	—			
b5	—			
b6	—			
b7	—			

Note:

- The RXD2 digital filter can be used only in clock asynchronous serial I/O (UART) mode. When bits SMD2 to SMD0 in the U2MR register are set to 001b (clock synchronous serial I/O mode) or 010b (I²C mode), set the DF2EN bit to 0 (RXD2 digital filter disabled).

22.2.8 UART2 Special Mode Register 5 (U2SMR5)

Address 00BBh

Bit	b7	b6	b5	b4	b3	b2	b1	b0
Symbol	—	—	—	MPIE	—	—	—	MP
After Reset	0	0	0	0	0	0	0	0

Bit	Symbol	Bit Name	Function	R/W
b0	MP	Multiprocessor communication enable bit	0: Multiprocessor communication disabled 1: Multiprocessor communication enabled ⁽¹⁾	R/W
b1	—	Nothing is assigned. If necessary, set to 0. When read, the content is 0.		—
b2	—			
b3	—			
b4	MPIE	Multiprocessor communication control bit	This bit is enabled when the MP bit is set to 1 (multiprocessor communication enabled). When the MPIE bit is set to 1, the following will result: <ul style="list-style-type: none"> Receive data in which the multiprocessor bit is 0 is ignored. Setting of the RI bit in the U2C1 register and bits OER and FER in the U2RB register to 1 is disabled. On receiving receive data in which the multiprocessor bit is 1, the MPIE bit is set to 0 and receive operation other than multiprocessor communication is performed. 	R/W
b5	—	Nothing is assigned. If necessary, set to 0. When read, the content is 0.		—
b6	—			
b7	—	Reserved bit	Set to 0.	R/W

Note:

- When the MP bit is set to 1 (multiprocessor communication enabled), the settings of bits PRY and PRYE in the U2MR register are disabled. If bits SMD2 to SMD0 in the U2MR register are set to 001b (clock synchronous serial I/O mode), set the MP bit to 0 (multiprocessor communication disabled).

22.2.9 UART2 Special Mode Register 4 (U2SMR4)

Address 00BCh

Bit	b7	b6	b5	b4	b3	b2	b1	b0
Symbol	SWC9	SCLHI	ACKC	ACKD	STSPSEL	STPREQ	RSTAREQ	STAREQ
After Reset	0	0	0	0	0	0	0	0

Bit	Symbol	Bit Name	Function	R/W
b0	STAREQ	Start condition generate bit ⁽¹⁾	0: Clear 1: Start	R/W
b1	RSTAREQ	Restart condition generate bit ⁽¹⁾	0: Clear 1: Start	R/W
b2	STPREQ	Stop condition generate bit ⁽¹⁾	0: Clear 1: Start	R/W
b3	STSPSEL	SCL, SDA output select bit	0: Start and stop conditions not output 1: Start and stop conditions output	R/W
b4	ACKD	ACK data bit	0: ACK 1: NACK	R/W
b5	ACKC	ACK data output enable bit	0: Serial interface data output 1: ACK data output	R/W
b6	SCLHI	SCL output stop enable bit	0: Disabled 1: Enabled	R/W
b7	SWC9	SCL wait bit 3	0: SCL "L" hold disabled 1: SCL "L" hold enabled	R/W

Note:

1. This bit is set to 0 when each condition is generated.

22.2.10 UART2 Special Mode Register 3 (U2SMR3)

Address 00BDh

Bit	b7	b6	b5	b4	b3	b2	b1	b0
Symbol	DL2	DL1	DL0	—	NODC	—	CKPH	—
After Reset	0	0	0	X	0	X	0	X

Bit	Symbol	Bit Name	Function	R/W
b0	—	Nothing is assigned. If necessary, set to 0. When read, the content is undefined.		—
b1	CKPH	Clock phase set bit	0: No clock delay 1: With clock delay	R/W
b2	—	Nothing is assigned. If necessary, set to 0. When read, the content is undefined.		—
b3	NODC	Clock output select bit	0: CLK2 set to CMOS output 1: CLK2 set to N-channel open-drain output	R/W
b4	—	Nothing is assigned. If necessary, set to 0. When read, the content is undefined.		—
b5	DL0	SDA2 digital delay setup bit ^(1, 2)	^{b7 b6 b5} 0 0 0: No delay 0 0 1: 1 to 2 cycle(s) of U2BRG count source 0 1 0: 2 to 3 cycles of U2BRG count source 0 1 1: 3 to 4 cycles of U2BRG count source 1 0 0: 4 to 5 cycles of U2BRG count source 1 0 1: 5 to 6 cycles of U2BRG count source 1 1 0: 6 to 7 cycles of U2BRG count source 1 1 1: 7 to 8 cycles of U2BRG count source	R/W
b6	DL1			R/W
b7	DL2			R/W

Notes:

1. Bits DL2 to DL0 are used to generate a delay in SDA2 output digitally in I²C mode. In other than I²C mode, set these bits to 000b (no delay).
2. The amount of delay varies with the load on pins SCL2 and SDA2. When an external clock is used, the amount of delay increases by about 100 ns.

22.2.11 UART2 Special Mode Register 2 (U2SMR2)

Address 00BEh

Bit	b7	b6	b5	b4	b3	b2	b1	b0
Symbol	—	SDHI	SWC2	STAC	—	SWC	CSC	IICM2
After Reset	X	0	0	0	0	0	0	0

Bit	Symbol	Bit Name	Function	R/W
b0	IICM2	I ² C mode select bit 2	Refer to Table 22.12 I²C Mode Functions .	R/W
b1	CSC	Clock synchronization bit	0: Disabled 1: Enabled	R/W
b2	SWC	SCL wait output bit	0: Disabled 1: Enabled	R/W
b3	—	Reserved bit	Set to 0.	R/W
b4	STAC	UART2 initialization bit	0: Disabled 1: Enabled	R/W
b5	SWC2	SCL wait output bit 2	0: Transfer clock 1: "L" output	R/W
b6	SDHI	SDA output disable bit	0: Enabled 1: Disabled (high-impedance)	R/W
b7	—	Nothing is assigned. If necessary, set to 0. When read, the content is undefined.		—

22.2.12 UART2 Special Mode Register (U2SMR)

Address 00BFh

Bit	b7	b6	b5	b4	b3	b2	b1	b0
Symbol	—	SSS	ACSE	ABSCS	—	BBS	—	IICM
After Reset	X	0	0	0	0	0	0	0

Bit	Symbol	Bit Name	Function	R/W
b0	IICM	I ² C mode select bit	0: Other than I ² C mode 1: I ² C mode	R/W
b1	—	Reserved bit	Set to 0.	R/W
b2	BBS	Bus busy flag ⁽¹⁾	0: Stop condition detected 1: Start condition detected (busy)	R/W
b3	—	Reserved bit	Set to 0.	R/W
b4	ABSCS	Bus collision detect sampling clock select bit	0: Rising edge of transfer clock 1: Underflow signal of Timer RB ⁽²⁾	
b5	ACSE	Auto clear function select bit of transmit enable bit	0: No auto clear function 1: Auto clear at bus collision occurrence	
b6	SSS	Transmit start condition select bit	0: Not synchronized to RXD2 1: Synchronized to RXD2 ⁽²⁾	
b7	—	Nothing is assigned. If necessary, set to 0. When read, the content is undefined.		—

Notes:

1. The BBS bit is set to 0 by writing 0 by a program (Writing 1 has no effect).
2. When a transfer begins, the SSS bit is set to 0 (not synchronized to RXD2).

22.2.13 UART2 Pin Select Register 0 (U2SR0)

Address 018Ah

Bit	b7	b6	b5	b4	b3	b2	b1	b0
Symbol	—	RXD2SEL2	RXD2SEL1	RXD2SEL0	—	TXD2SEL2	TXD2SEL1	TXD2SEL0
After Reset	0	0	0	0	0	0	0	0

Bit	Symbol	Bit Name	Function	R/W
b0	TXD2SEL0	TXD2/SDA2 pin select bit	b2 b1 b0 0 0 0: TXD2/SDA2 pin not used 0 0 1: P3_7 assigned 0 1 1: P0_0 assigned 1 1 0: P3_6 assigned Other than above: Do not set.	R/W
b1	TXD2SEL1			R/W
b2	TXD2SEL2			R/W
b3	—	Nothing is assigned. If necessary, set to 0. When read, the content is 0.		—
b4	RXD2SEL0	RXD2/SCL2 pin select bit	b6 b5 b4 0 0 0: RXD2/SCL2 pin not used 0 1 0: P3_7 assigned 0 1 1: P4_5 assigned 1 1 0: P3_6 assigned Other than above: Do not set.	R/W
b5	RXD2SEL1			R/W
b6	RXD2SEL2			R/W
b7	—	Nothing is assigned. If necessary, set to 0. When read, the content is 0.		—

The U2SR0 register selects which pin is assigned to the UART2 I/O. To use the I/O pin for UART2, set this register.

Set the U2SR0 register before setting the UART2 associated registers. Also, do not change the setting value in this register during UART2 operation.

22.2.14 UART2 Pin Select Register 1 (U2SR1)

Address 018Bh

Bit	b7	b6	b5	b4	b3	b2	b1	b0
Symbol	—	—	—	CTS2SEL0	—	—	CLK2SEL1	CLK2SEL0
After Reset	0	0	0	0	0	0	0	0

Bit	Symbol	Bit Name	Function	R/W
b0	CLK2SEL0	CLK2 pin select bit	b1 b0 0 0: CLK2 pin not used 0 1: P3_5 assigned 1 0: P0_5 assigned 1 1: Do not set.	R/W
b1	CLK2SEL1			R/W
b2	—	Nothing is assigned. If necessary, set to 0. When read, the content is 0.		—
b3	—			—
b4	CTS2SEL0	CTS2/RTS2 pin select bit	0: CTS2/RTS2 pin not used 1: P3_3 assigned	R/W
b5	—	Reserved bit	Set to 0.	R/W
b6	—	Nothing is assigned. If necessary, set to 0. When read, the content is 0.		—
b7	—			—

The U2SR1 register selects which pin is assigned to the UART2 I/O. To use the I/O pin for UART2, set this register.

Set the U2SR1 register before setting the UART2 associated registers. Also, do not change the setting value in this register during UART2 operation.

22.3 Clock Synchronous Serial I/O Mode

In clock synchronous serial I/O mode, data is transmitted and received using a transfer clock.

Table 22.2 lists the Clock Synchronous Serial I/O Mode Specifications. Table 22.3 lists the Registers Used and Settings in Clock Synchronous Serial I/O Mode.

Table 22.2 Clock Synchronous Serial I/O Mode Specifications

Item	Specification
Transfer data format	Transfer data length: 8 bits
Transfer clock	<ul style="list-style-type: none"> The CKDIR bit in the U2MR register is set to 0 (internal clock): $f_j/(2(n+1))$ $f_j = f_1, f_8, f_{32}$ n = setting value in the U2BRG register: 00h to FFh The CKDIR bit is set to 1 (external clock): Input from the CLK2 pin
Transmit/receive control	Selectable from the $\overline{\text{CTS}}$ function, $\overline{\text{RTS}}$ function, or $\overline{\text{CTS/RTS}}$ function disabled.
Transmit start conditions	To start transmission, the following requirements must be met: ⁽¹⁾ <ul style="list-style-type: none"> The TE bit in the U2C1 register is set to 1 (transmission enabled) The TI bit in the U2C1 register is set to 0 (data present in the U2TB register) If the $\overline{\text{CTS}}$ function is selected, input to the CTS2 pin = "L".
Receive start conditions	To start reception, the following requirements must be met: ⁽¹⁾ <ul style="list-style-type: none"> The RE bit in the U2C1 register is set to 1 (reception enabled). The TE bit in the U2C1 register is set to 1 (transmission enabled). The TI bit in the U2C1 register is set to 0 (data present in the U2TB register).
Interrupt request generation timing	For transmission, one of the following conditions can be selected. <ul style="list-style-type: none"> The U2IRS bit in the U2C1 register is set to 0 (transmit buffer empty): When data is transferred from the U2TB register to the UART2 transmit register (at start of transmission). The U2IRS bit is set to 1 (transmission completed): When data transmission from the UART2 transmit register is completed. For reception <ul style="list-style-type: none"> When data is transferred from the UART2 receive register to the U2RB register (at completion of reception).
Error detection	Overrun error ⁽²⁾ This error occurs if the serial interface starts receiving the next unit of data before reading the U2RB register and receives the 7th bit of the next unit of data.
Selectable functions	<ul style="list-style-type: none"> CLK polarity selection Transfer data I/O can be selected to occur synchronously with the rising or falling edge of the transfer clock. LSB first, MSB first selection Whether transmitting or receiving data begins with bit 0 or begins with bit 7 can be selected. Continuous receive mode selection Reception is enabled immediately by reading the U2RB register. Serial data logic switching This function inverts the logic value of the transmit/receive data.

Notes:

- When an external clock is selected, the requirements must be met in either of the following states:
 - The external clock is held high when the CKPOL bit in the U2C0 register is set to 0 (transmit data output at the falling edge and receive data input at the rising edge of the transfer clock)
 - The external clock is held low when the CKPOL bit in the U2C0 register is set to 1 (transmit data output at the rising edge and receive data input at the falling edge of the transfer clock)
- If an overrun error occurs, the receive data in the U2RB register will be undefined. The IR bit in the S2RIC register does not change to 1 (interrupt requested).

Table 22.3 Registers Used and Settings in Clock Synchronous Serial I/O Mode

Register	Bit	Function
U2TB (1)	b0 to b7	Set transmit data.
U2RB (1)	b0 to b7	Receive data can be read.
	OER	Overrun error flag
U2BRG	b0 to b7	Set a bit rate.
U2MR (1)	SMD2 to SMD0	Set to 001b.
	CKDIR	Select the internal clock or external clock.
	IOPOL	Set to 0.
U2C0	CLK1, CLK0	Select the count source for the U2BRG register.
	CRS	Select either $\overline{\text{CTS}}$ or $\overline{\text{RTS}}$ to use functions.
	TXEPT	Transmit register empty flag
	CRD	Enable or disable the $\overline{\text{CTS}}$ or $\overline{\text{RTS}}$ function.
	NCH	Select TXD2 pin output mode.
	CKPOL	Select the transfer clock polarity.
	UFORM	Select LSB first or MSB first.
U2C1	TE	Set to 1 to enable transmission/reception.
	TI	Transmit buffer empty flag
	RE	Set to 1 to enable reception.
	RI	Receive complete flag
	U2IRS	Select the source of UART2 transmit interrupt.
	U2RRM	Set to 1 to use continuous receive mode.
	U2LCH	Set to 1 to use inverted data logic.
	U2ERE	Set to 0.
U2SMR	b0 to b7	Set to 0.
U2SMR2	b0 to b7	Set to 0.
U2SMR3	b0 to b2	Set to 0.
	NODC	Select clock output mode.
	b4 to b7	Set to 0.
U2SMR4	b0 to b7	Set to 0.
URXDF	DF2EN	Set to 0.
U2SMR5	MP	Set to 0.

Note:

1. Set the bits not listed in this table to 0 when writing to the above registers in clock synchronous serial I/O mode.

Table 22.4 lists the Pin Functions in Clock Synchronous Serial I/O Mode (Multiple Transfer Clock Output Pin Function Not Selected).

Note that for a period from when UART2 operating mode is selected to when transfer starts, the TXD2 pin outputs a “H” level. (When N-channel open-drain output is selected, this pin is in the high-impedance state.)

Figure 22.3 shows the Transmit and Receive Timing in Clock Synchronous Serial I/O Mode.

Table 22.4 Pin Functions in Clock Synchronous Serial I/O Mode (Multiple Transfer Clock Output Pin Function Not Selected)

Pin Name	Function	Selection Method
TXD2 (P0_0, P3_6, or P3_7)	Serial data output	<ul style="list-style-type: none"> When TXD2 (P0_0) TXD2SEL2 to TXD2SEL0 bits in U2SR0 register = 011b(P0_0) When TXD2 (P3_6) TXD2SEL2 to TXD2SEL0 bits in U2SR0 register = 110b(P3_6) When TXD2 (P3_7) TXD2SEL2 to TXD2SEL0 bits in U2SR0 register = 001b(P3_7) For reception only: P0_0, P3_6, and P3_7 can be used as ports by setting bits TXD2SEL2 to TXD2SEL0 to 000b.
RXD2 (P3_6, P3_7, or P4_5)	Serial data input	<ul style="list-style-type: none"> When RXD2 (P3_6) RXD2SEL2 to RXD2SEL0 bits in U2SR0 register = 110b(P3_6) PD3_4 bit in PD3 register = 0 When RXD2 (P3_7) RXD2SEL2 to RXD2SEL0 bits in U2SR0 register = 010b(P3_7) PD3_7 bit in PD3 register = 0 When RXD2 (P4_5) RXD2SEL2 to RXD2SEL0 bits in U2SR0 register = 011b(P4_5) PD6_7 bit in PD6 register = 0 For transmission only: P3_6, P3_7, and P4_5 can be used as ports by setting bits RXD2SEL2 to RXD2SEL0 to 00b.
CLK2 (P3_5 or P3_5)	Transfer clock output	<ul style="list-style-type: none"> When CLK2 (P0_5) CLK2SEL1, CLK2SEL0 bit in U2SR1 register = 10b(P0_5) CKDIR bit in U2MR register = 0 When CLK2 (P3_5) CLK2SEL1, CLK2SEL0 bit in U2SR1 register = 01b(P3_5) CKDIR bit in U2MR register = 0
	Transfer clock input	<ul style="list-style-type: none"> When CLK2 (P0_5) CLK2SEL1, CLK2SEL0 bit in U2SR1 register = 10b(P0_5) CKDIR bit in U2MR register = 1 PD0_5 bit in PD3 register = 0 When CLK2 (P3_5) CLK2SEL1, CLK2SEL0 bit in U2SR1 register = 01b(P3_5) CKDIR bit in U2MR register = 1 PD3_5 bit in PD6 register = 0
CTS2/RTS2(P3_3)	CTS input	CTS2SEL0 bit in U2SR1 register = 1 CRD bit in U2C0 register = 0 CRS bit in U2C0 register = 0 PD3_3 bit in PD3 register = 0
	RTS output	CTS2SEL0 bit in U2SR1 register = 1 CRD bit in U2C0 register = 0 CRS bit in U2C0 register = 1
	I/O port	CTS2SEL0 bit in U2SR1 register = 0

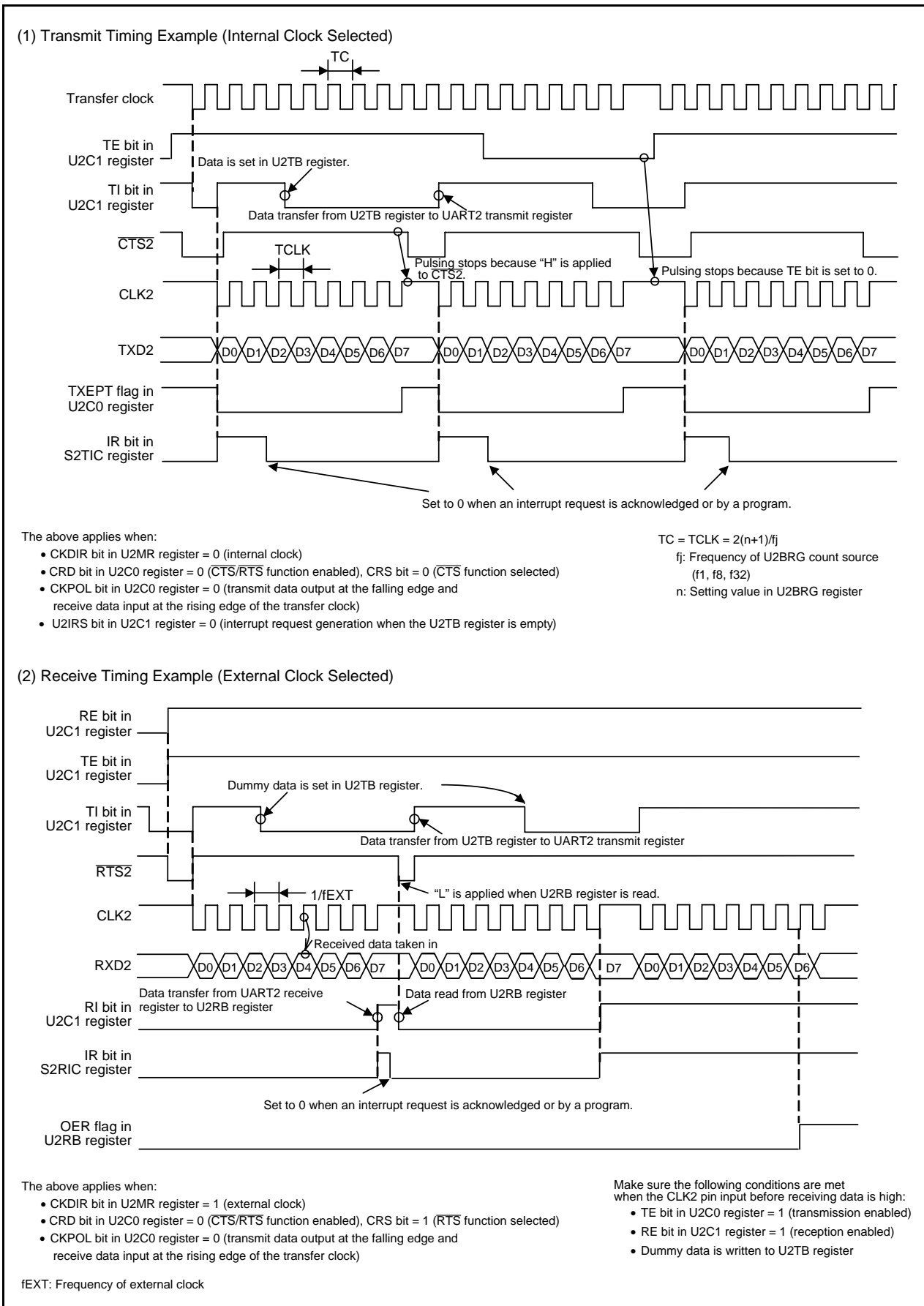

Figure 22.3 Transmit and Receive Timing in Clock Synchronous Serial I/O Mode

22.3.1 Measure for Dealing with Communication Errors

If communication is aborted or a communication error occurs while transmitting or receiving in clock synchronous serial I/O mode, follow the procedures below:

- (1) Set the TE bit in the U2C1 register to 0 (transmission disabled) and the RE bit to 0 (reception disabled).
- (2) Set bits SMD2 to SMD0 in the U2MR register to 000b (serial interface disabled).
- (3) Set bits SMD2 to SMD0 in the U2MR register to 001b (clock synchronous serial I/O mode).
- (4) Set the TE bit in the U2C1 register to 1 (transmission enabled) and the RE bit to 1 (reception enabled).

22.3.2 CLK Polarity Select Function

Use the CKPOL bit in the U2C0 register to select the transfer clock polarity. Figure 22.4 shows the Transfer Clock Polarity.

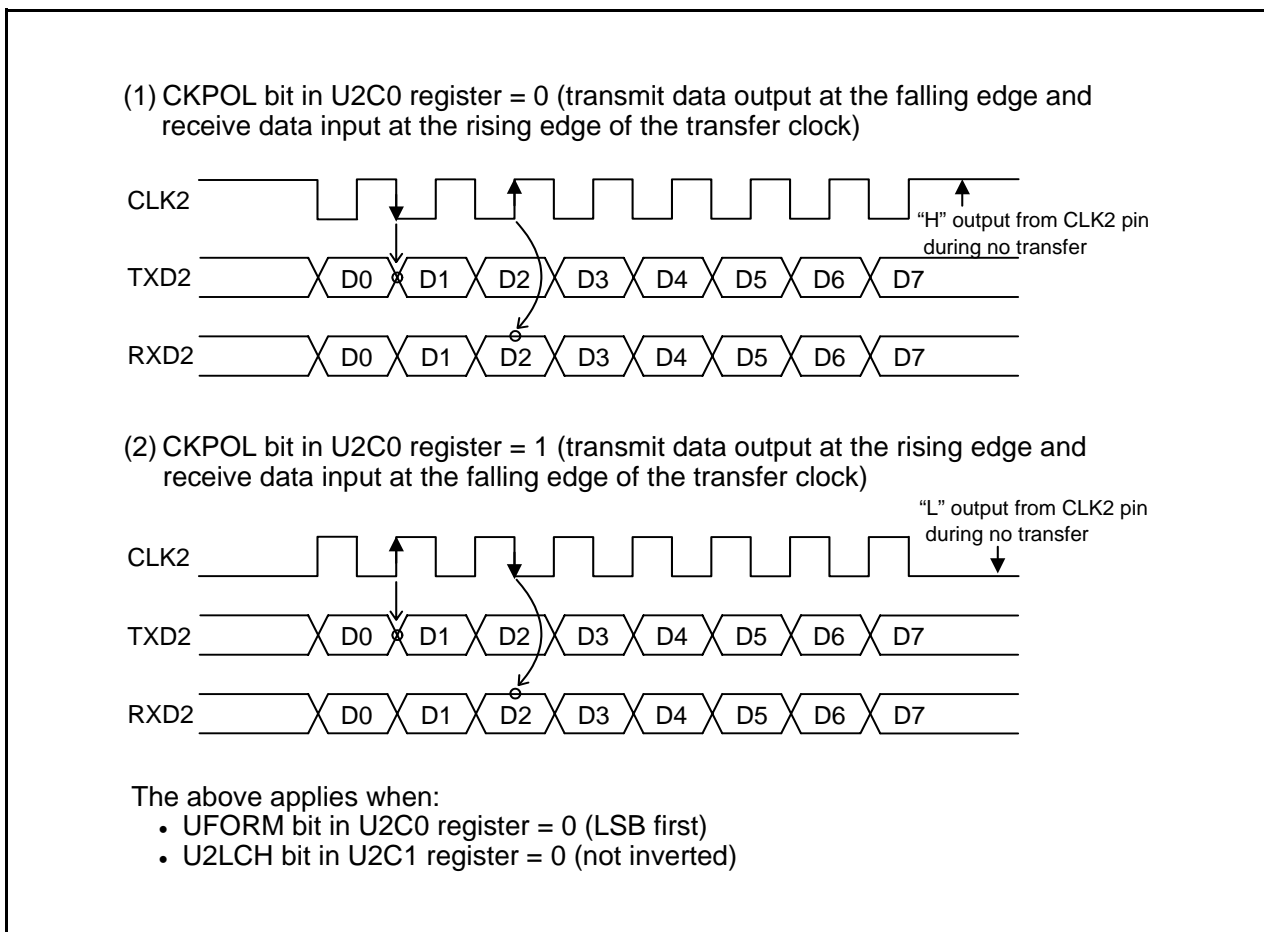

Figure 22.4 Transfer Clock Polarity

22.3.3 LSB First/MSB First Select Function

Use the UFORM bit in the U2C0 register to select the transfer format. Figure 22.5 shows the Transfer Format.

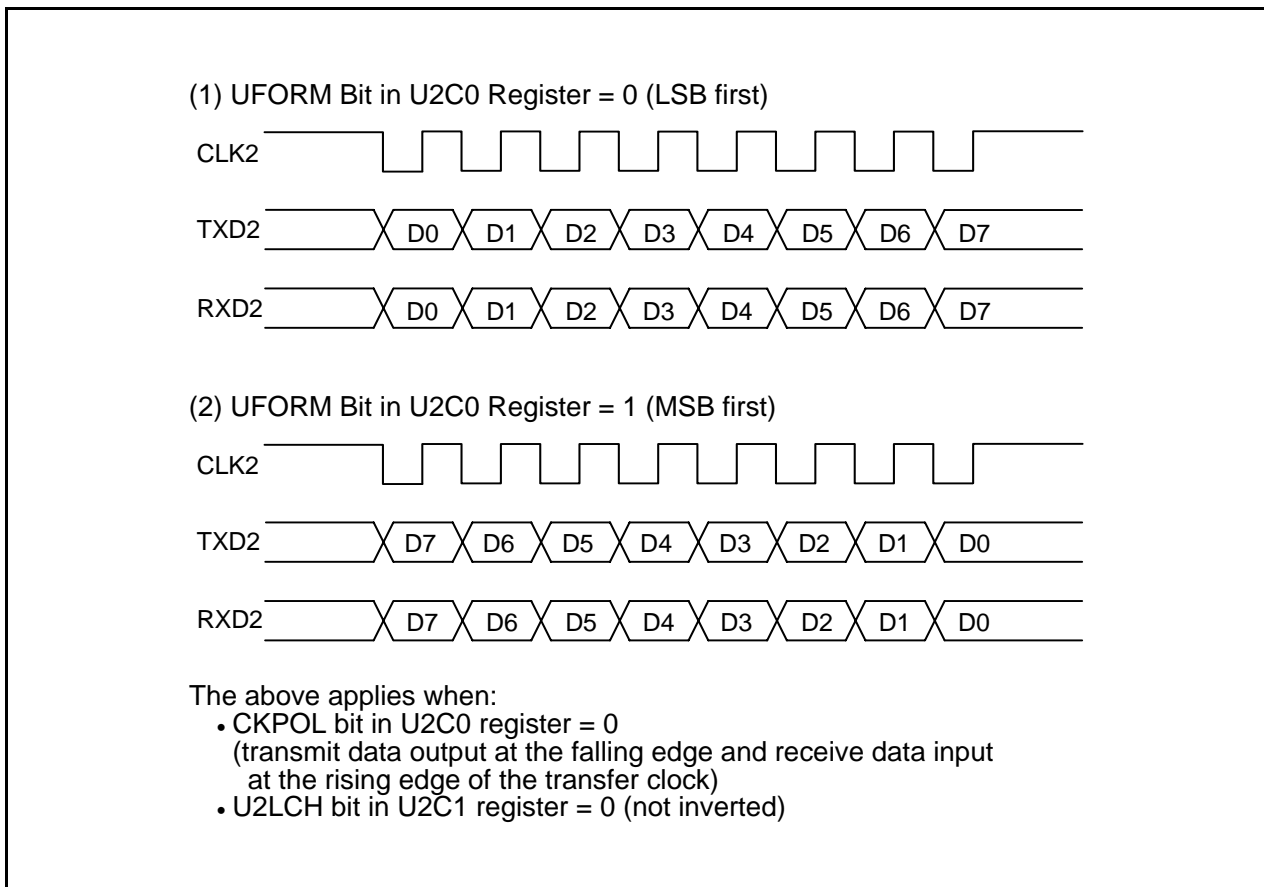

Figure 22.5 Transfer Format

22.3.4 Continuous Receive Mode

In continuous receive mode, receive operation is enabled when the receive buffer register is read. It is not necessary to write dummy data to the transmit buffer register to enable receive operation in this mode. However, a dummy read of the receive buffer register is required when starting the operating mode.

When the U2RRM bit in the U2C1 register is set to 1 (continuous receive mode), the TI bit in the U2C1 register is set to 0 (data present in the U2TB register) by reading the U2RB register. If the U2RRM bit is set to 1, do not write dummy data to the U2TB register by a program.

22.3.5 Serial Data Logic Switching Function

If the U2LCH bit in the U2C1 register is set to 1 (inverted), the data written to the U2TB register has its logic inverted before being transmitted. Similarly, the received data has its logic inverted when read from the U2RB register. Figure 22.6 shows the Serial Data Logic Switching.

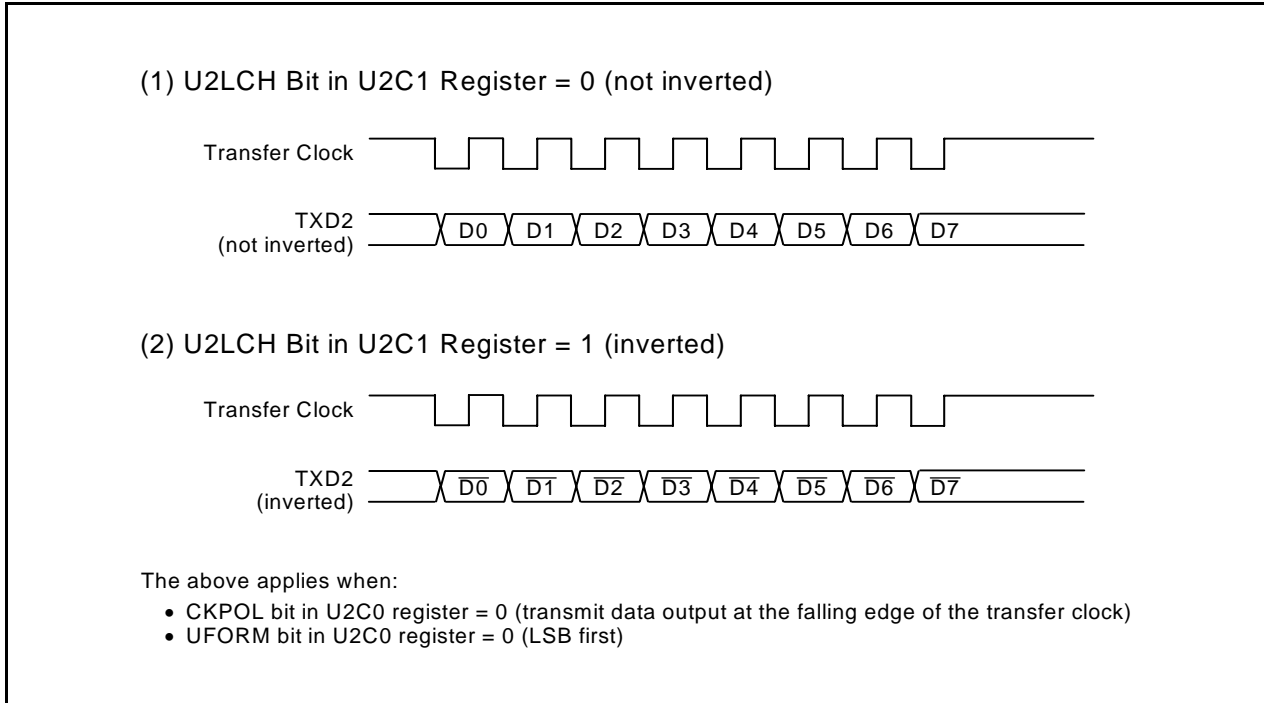

Figure 22.6 Serial Data Logic Switching

22.3.6 CTS/RTS Function

The $\overline{\text{CTS}}$ function is used to start transmit and receive operation when “L” is applied to the $\overline{\text{CTS2/RTS2}}$ pin. Transmit and receive operation begins when the $\overline{\text{CTS2/RTS2}}$ pin is held low. If the “L” signal is switched to “H” during a transmit or receive operation, the operation stops before the next data.

For the $\overline{\text{RTS}}$ function, the $\overline{\text{CTS2/RTS2}}$ pin outputs “L” when the MCU is ready for a receive operation. The output level goes high at the first falling edge of the CLK2 pin.

- The CRD bit in the U2C0 register = 1 ($\overline{\text{CTS/RTS}}$ function disabled)
The $\overline{\text{CTS2/RTS2}}$ pin operates as the programmable I/O function.
- The CRD bit = 0, CRS bit = 0 ($\overline{\text{CTS}}$ function selected)
The $\overline{\text{CTS2/RTS2}}$ pin operates as the $\overline{\text{CTS}}$ function.
- The CRD bit = 0, CRS bit = 1 ($\overline{\text{RTS}}$ function selected)
The $\overline{\text{CTS2/RTS2}}$ pin operates as the $\overline{\text{RTS}}$ function.

22.4 Clock Asynchronous Serial I/O (UART) Mode

In UART mode, data is transmitted and received after setting the desired bit rate and transfer data format. Table 22.5 lists the UART Mode Specifications. Table 22.6 lists the Registers Used and Settings in UART Mode.

Table 22.5 UART Mode Specifications

Item	Specification
Transfer data format	<ul style="list-style-type: none"> Character bits (transfer data): Selectable from 7, 8, or 9 bits Start bit: 1 bit Parity bit: Selectable from odd, even, or none Stop bits: Selectable from 1 bit or 2 bits
Transfer clock	<ul style="list-style-type: none"> The CKDIR bit in the U2MR register is set to 0 (internal clock): $f_j / (16(n + 1))$ $f_j = f_1, f_8, f_{32}$ $n =$ setting value in the U2BRG register: 00h to FFh The CKDIR bit is set to 1 (external clock): $f_{EXT} / (16(n + 1))$ f_{EXT}: Input from CLK2 pin n: Setting value in the U2BRG register: 00h to FFh
Transmit/receive control	Selectable from the \overline{CTS} function, \overline{RTS} function, or $\overline{CTS}/\overline{RTS}$ function disabled.
Transmit start conditions	To start transmission, the following requirements must be met: <ul style="list-style-type: none"> The TE bit in the U2C1 register is set to 1 (transmission enabled). The T1 bit in the U2C1 register is set to 0 (data present in the U2TB register). If the \overline{CTS} function is selected, input to the $\overline{CTS2}$ pin = "L".
Receive start conditions	To start reception, the following requirements must be met: <ul style="list-style-type: none"> The RE bit in the U2C1 register is set to 1 (reception enabled). Start bit detection
Interrupt request generation timing	For transmission, one of the following conditions can be selected. <ul style="list-style-type: none"> The U2IRS bit in the U2C1 register is set to 0 (transmit buffer empty): When data is transferred from the U2TB register to the UART2 transmit register (at start of transmission). The U2IRS bit is set to 1 (transmission completed): When data transmission from the UART2 transmit register is completed. For reception <ul style="list-style-type: none"> When data is transferred from the UART2 receive register to the U2RB register (at completion of reception).
Error detection	<ul style="list-style-type: none"> Overrun error ⁽¹⁾ This error occurs if the serial interface starts receiving the next unit of data before reading the U2RB register and receives the bit one before the last stop bit of the next unit of data. Framing error ⁽²⁾ This error occurs when the set number of stop bits is not detected. Parity error ⁽²⁾ This error occurs when if parity is enabled, the number of 1's in the parity and character bits does not match the set number of 1's. Error sum flag This flag is set to 1 if an overrun, framing, or parity error occurs.
Selectable functions	<ul style="list-style-type: none"> LSB first, MSB first selection Whether transmitting or receiving data begins with bit 0 or begins with bit 7 can be selected. Serial data logic switching This function inverts the logic of the transmit/receive data. The start and stop bits are not inverted. TXD, RXD I/O polarity switching This function inverts the polarities of the TXD pin output and RXD pin input. The logic levels of all I/O data are inverted. RXD2 digital filter selection The RXD2 input signal can be enabled or disabled.

Notes:

- If an overrun error occurs, the receive data in the U2RB register will be undefined.
- The framing error flag and the parity error flag are set to 1 when data is transferred from the UART2 receive register to the U2RB register.

Table 22.6 Registers Used and Settings in UART Mode

Register	Bit	Function
U2TB	b0 to b8	Set transmit data. (1)
U2RB	b0 to b8	Receive data can be read. (1, 2)
	OER, FER, PER, SUM	Error flag
U2BRG	b0 to b7	Set a bit rate.
U2MR	SMD2 to SMD0	Set to 100b when transfer data is 7 bits long. Set to 101b when transfer data is 8 bits long. Set to 110b when transfer data is 9 bits long.
	CKDIR	Select the internal clock or external clock.
	STPS	Select the stop bit.
	PRY, PRYE	Select whether parity is included and whether odd or even.
	IOPOL	Select the TXD/RXD I/O polarity.
U2C0	CLK0, CLK1	Select the count source for the U2BRG register.
	CRS	Select $\overline{\text{CTS}}$ or $\overline{\text{RTS}}$ to use functions.
	TXEPT	Transmit register empty flag
	CRD	Enable or disable the $\overline{\text{CTS}}$ or $\overline{\text{RTS}}$ function.
	NCH	Select TXD2 pin output mode.
	CKPOL	Set to 0.
	UFORM	Select LSB first or MSB first when transfer data is 8 bits long. Set to 0 when transfer data is 7 or 9 bits long.
U2C1	TE	Set to 1 to enable transmission.
	TI	Transmit buffer empty flag
	RE	Set to 1 to enable reception.
	RI	Receive complete flag
	U2IRS	Select the UART2 transmit interrupt source.
	U2RRM	Set to 0.
	U2LCH	Set to 1 to use inverted data logic.
	U2ERE	Set to 0.
U2SMR	b0 to b7	Set to 0.
U2SMR2	b0 to b7	Set to 0.
U2SMR3	b0 to b7	Set to 0.
U2SMR4	b0 to b7	Set to 0.
URXDF	DF2EN	Select the digital filter disabled or enabled.
U2SMR5	MP	Set to 0.

Notes:

- The bits used for transmit/receive data are as follows:
 - Bits b0 to b6 when transfer data is 7 bits long
 - Bits b0 to b7 when transfer data is 8 bits long
 - Bits b0 to b8 when transfer data is 9 bits long
- The contents of the following are undefined:
 - Bits b7 and b8 when transfer data is 7 bits long
 - Bit b8 when transfer data is 8 bits long

Table 22.7 lists the I/O Pin Functions in UART Mode.

Note that for a period from when the UART2 operating mode is selected to when transfer starts, the TXD2 pin outputs “H”. (When N-channel open-drain output is selected, this pin is in the high-impedance state.)

Figure 22.7 shows the Transmit Timing in UART Mode. Figure 22.8 shows the Receive Timing in UART Mode.

Table 22.7 I/O Pin Functions in UART Mode

Pin Name	Function	Selection Method
TXD2 (P0_0, P3_6 or P3_7)	Serial data output	<ul style="list-style-type: none"> • When TXD2 (P0_0) TXD2SEL2 to TXD2SEL0 bits in U2SR0 register = 011b (P0_0) • When TXD2 (P3_6) TXD2SEL2 to TXD2SEL0 bits in U2SR0 register = 110b (P3_6) • When TXD2 (P3_7) TXD2SEL2 to TXD2SEL0 bits in U2SR0 register = 001b (P3_7) • For reception only: P0_0, P3_6, and P3_7 can be used as ports by setting bits TXD2SEL2 to TXD2SEL0 to 000b.
RXD2 (P3_6, P3_7 or P4_5)	Serial data input	<ul style="list-style-type: none"> • When RXD2 (P3_6) RXD2SEL2 to RXD2SEL0 bits in U2SR0 register = 110b (P3_6) PD3_4 bit in PD3 register = 0 • When RXD2 (P3_7) RXD2SEL2 to RXD2SEL0 bits in U2SR0 register = 010b (P3_7) PD3_7 bit in PD3 register = 0 • When RXD2 (P4_5) RXD2SEL2 to RXD2SEL0 bits in U2SR0 register = 011b (P4_5) PD6_7 bit in PD6 register = 0 • For transmission only: P3_6, P3_7, and P4_5 can be used as ports by setting bits RXD2SEL2 to RXD2SEL0 to 000b.
CLK2 (P0_5 or P3_5)	I/O port	CLK2SEL1 to CLK2SEL0 bits in U2SR1 register = 00b
	Transfer clock input	<ul style="list-style-type: none"> • When CLK2 (P0_5) CLK2SEL1, CLK2SEL0 bit in U2SR1 register = 10b (P0_5) CKDIR bit in U2MR register = 1 PD3_5 bit in PD3 register = 0 • When CLK2 (P3_5) CLK2SEL1, CLK2SEL0 bit in U2SR1 register = 01b (P3_5) CKDIR bit in U2MR register = 1 PD6_5 bit in PD6 register = 0
CTS2/RTS2 (P3_3)	CTS input	CTS2SEL0 bit in U2SR1 register = 1 CRD bit in U2C0 register = 0 CRS bit in U2C0 register = 0 PD3_3 bit in PD3 register = 0
	RTS output	CTS2SEL0 bit in U2SR1 register = 1 CRD bit in U2C0 register = 0 CRS bit in U2C0 register = 1
	I/O port	CTS2SEL0 bit in U2SR1 register = 0

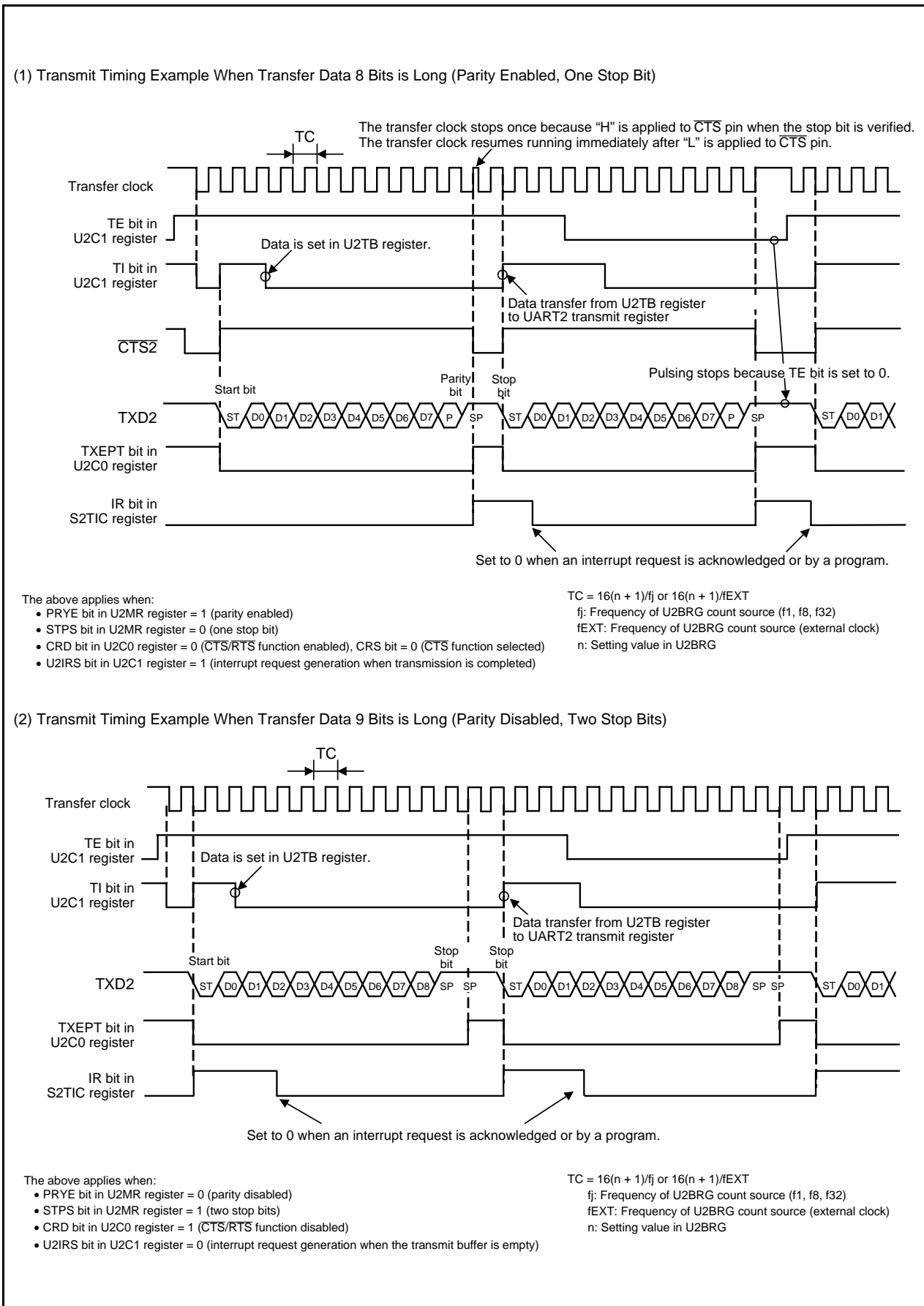

Figure 22.7 Transmit Timing in UART Mode

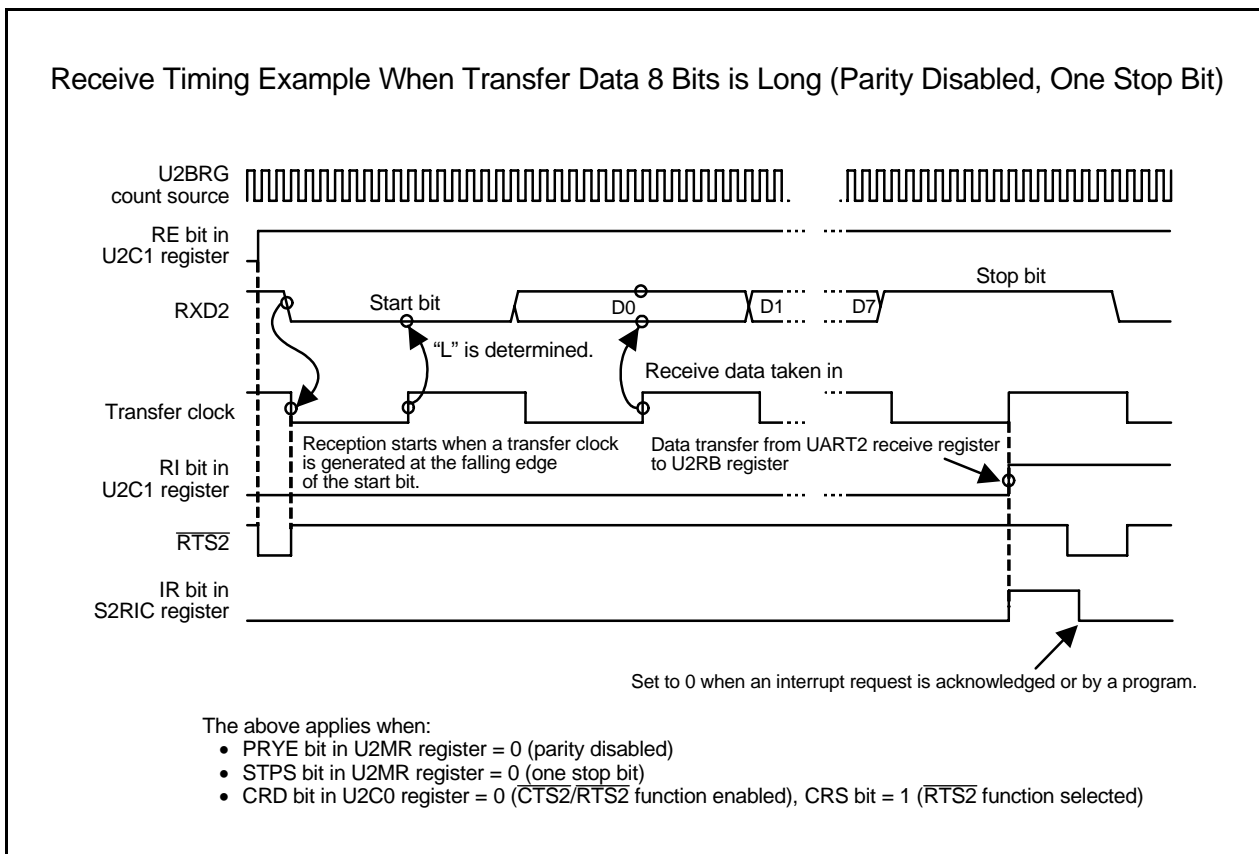

Figure 22.8 Receive Timing in UART Mode

22.4.1 Bit Rate

In UART mode, the bit rate is the frequency divided by the U2BRG register divided by 16. Table 22.8 lists the Bit Rate Setting Example in UART Mode (Internal Clock Selected).

Table 22.8 Bit Rate Setting Example in UART Mode (Internal Clock Selected)

Bit Rate (bps)	U2BRG Count Source	System Clock = 20 MHz			System Clock = 18.432 MHz ⁽¹⁾			System Clock = 8 MHz		
		U2BRG Setting Value	Actual Time (bps)	Setting Error (%)	U2BRG Setting Value	Actual Time (bps)	Setting Error (%)	U2BRG Setting Value	Actual Time (bps)	Setting Error (%)
1200	f8	129 (81h)	1201.92	0.16	119 (77h)	1200.00	0.00	51 (33h)	1201.92	0.16
2400	f8	64 (40h)	2403.85	0.16	59 (3Bh)	2400.00	0.00	25 (19h)	2403.85	0.16
4800	f8	32 (20h)	4734.85	-1.36	29 (1Dh)	4800.00	0.00	12 (0Ch)	4807.69	0.16
9600	f1	129 (81h)	9615.38	0.16	119 (77h)	9600.00	0.00	51 (33h)	9615.38	0.16
14400	f1	86 (56h)	14367.82	-0.22	79 (4Fh)	14400.00	0.00	34 (22h)	14285.71	-0.79
19200	f1	64 (40h)	19230.77	0.16	59 (3Bh)	19200.00	0.00	25 (19h)	19230.77	0.16
28800	f1	42 (2Ah)	29069.77	0.94	39 (27h)	28800.00	0.00	16 (10h)	29411.76	2.12
38400	f1	32 (20h)	37878.79	-1.36	29 (1Dh)	38400.00	0.00	12 (0Ch)	38461.54	0.16
57600	f1	21 (15h)	56818.18	-1.36	19 (13h)	57600.00	0.00	8 (08h)	55555.56	-3.55
115200	f1	10 (0Ah)	113636.36	-1.36	9 (09h)	115200.00	0.00	-	-	-

Note:

1. For the high-speed on-chip oscillator, the correction value in the FRA4 register should be written into the FRA1 register and the correction value in the FRA5 register should be written into the FRA3 register. This applies when the high-speed on-chip oscillator is selected as the system clock and bits FRA22 to FRA20 in the FRA2 register are set to 000b (divide-by-2 mode). For the precision of the high-speed on-chip oscillator, refer to **30. Electrical Characteristics**.

22.4.2 Measure for Dealing with Communication Errors

If communication is aborted or a communication error occurs while transmitting or receiving in UART mode, follow the procedures below:

- (1) Set the TE bit in the U2C1 register to 0 (transmission disabled) and the RE bit to 0 (reception disabled).
- (2) Set bits SMD2 to SMD0 in the U2MR register to 000b (serial interface disabled).
- (3) Set bits SMD2 to SMD0 in the U2MR register to 100b (UART mode, transfer data 7 bits long), 101b (UART mode, transfer data 8 bits long), or 110b (UART mode, transfer data 9 bits long).
- (4) Set the TE bit in the U2C1 register to 1 (transmission enabled) and the RE bit to 1 (reception enabled).

22.4.3 LSB First/MSB First Select Function

As shown in Figure 22.9, use the UFORM bit in the U2C0 register to select the transfer format. This function is enabled when transfer data is 8 bits long. Figure 22.9 shows the Transfer Format.

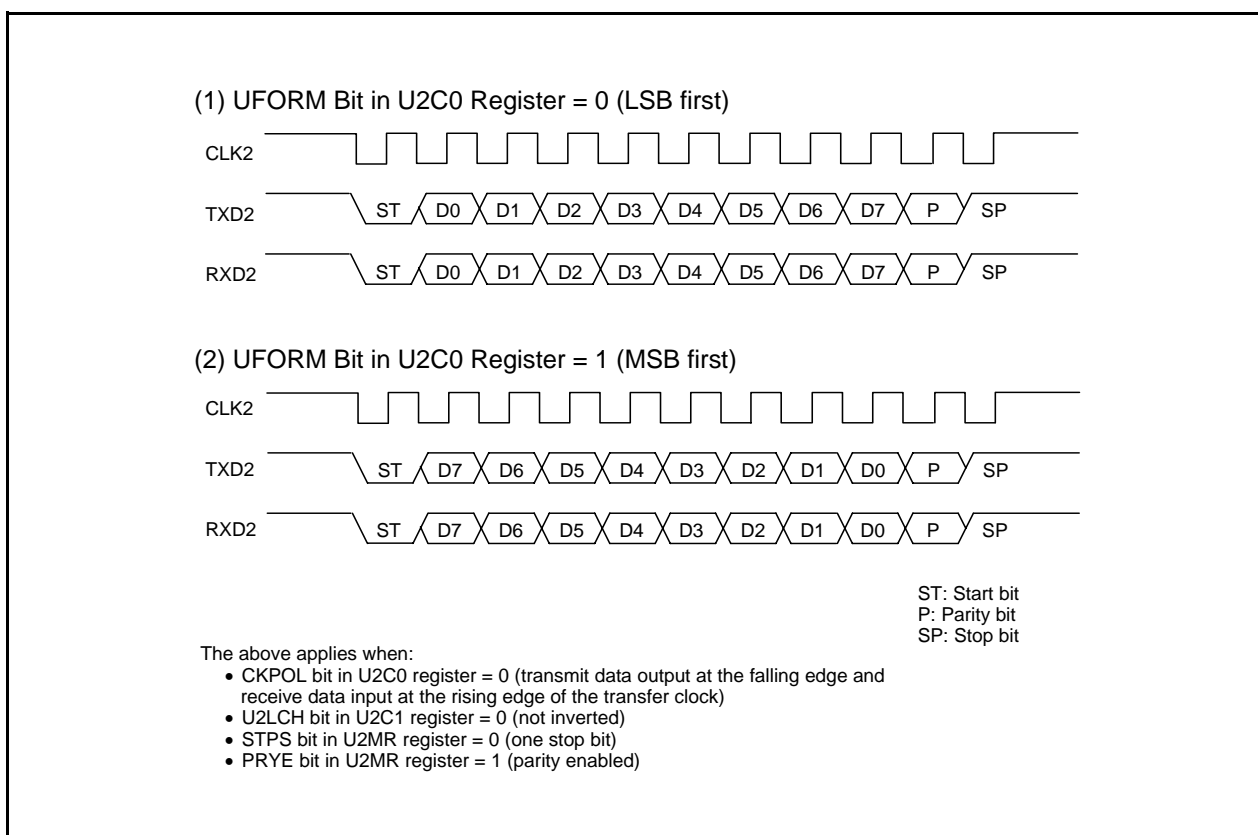

Figure 22.9 Transfer Format

22.4.4 Serial Data Logic Switching Function

The data written to the U2TB register has its logic inverted before being transmitted. Similarly, the received data has its logic inverted when read from the U2RB register. Figure 22.10 shows the Serial Data Logic Switching.

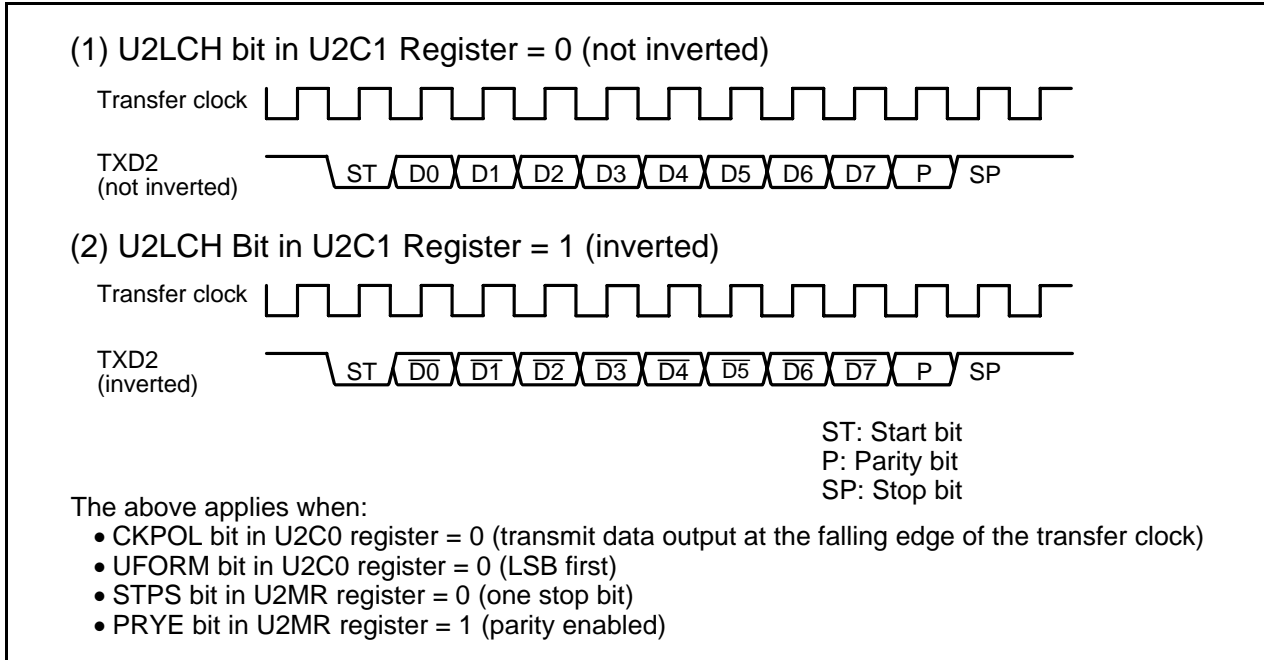

Figure 22.10 Serial Data Logic Switching

22.4.5 TXD and RXD I/O Polarity Inverse Function

This function inverts the polarities of the TXD2 pin output and RXD2 pin input. The logic levels of all I/O data (including bits for start, stop, and parity) are inverted. Figure 22.11 shows the TXD and RXD I/O Inversion.

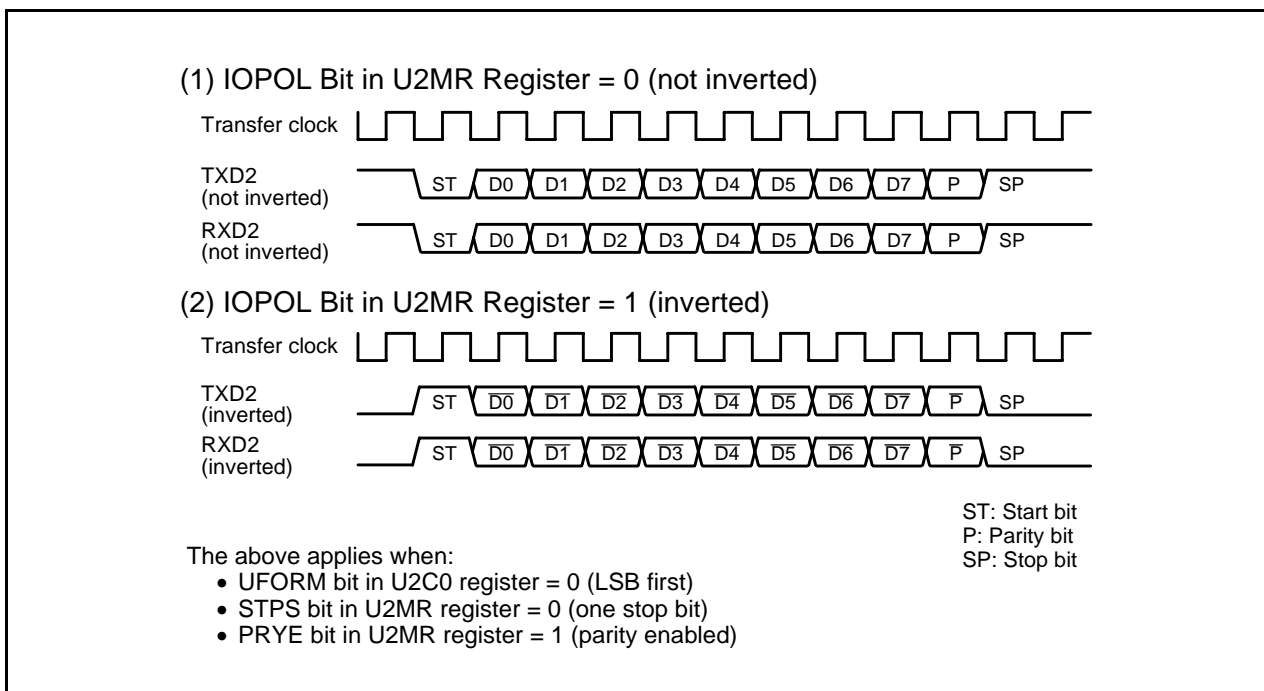

Figure 22.11 TXD and RXD I/O Inversion

22.4.6 $\overline{\text{CTS}}/\overline{\text{RTS}}$ Function

The $\overline{\text{CTS}}$ function is used to start transmit operation when “L” is applied to the $\overline{\text{CTS2}}/\overline{\text{RTS2}}$ pin. Transmit operation begins when the $\overline{\text{CTS2}}/\overline{\text{RTS2}}$ pin is held low. If the “L” signal is switched to “H” during transmit operation, the operation stops after the ongoing transmit/receive operation is completed.

When the $\overline{\text{RTS}}$ function is used, the $\overline{\text{CTS2}}/\overline{\text{RTS2}}$ pin outputs “L” when the MCU is ready for a receive operation.

- The CRD bit in the U2C0 register = 1 ($\overline{\text{CTS}}/\overline{\text{RTS}}$ function disabled)
The $\overline{\text{CTS2}}/\overline{\text{RTS2}}$ pin operates as the programmable I/O function.
- The CRD bit = 0, CRS bit = 0 ($\overline{\text{CTS}}$ function selected)
The $\overline{\text{CTS2}}/\overline{\text{RTS2}}$ pin operates as the $\overline{\text{CTS}}$ function.
- The CRD bit = 0, CRS bit = 1 ($\overline{\text{RTS}}$ function selected)
The $\overline{\text{CTS2}}/\overline{\text{RTS2}}$ pin operates as the $\overline{\text{RTS}}$ function.

22.4.7 RXD2 Digital Filter Select Function

When the DF2EN bit in the URXDF register is set to 1 (RXD2 digital filter enabled), the RXD2 input signal is loaded internally via the digital filter circuit for noise reduction. The noise canceller consists of three cascaded latch circuits and a match detection circuit. The RXD2 input signal is sampled on the internal basic clock with a frequency 16 times the bit rate. It is recognized as a signal and the level is passed forward to the next circuit when three latch outputs match. When the outputs do not match, the previous value is retained.

In other words, when the level is changed within three clocks, the change is recognized as not a signal but noise. Figure 22.12 shows a Block Diagram of RXD2 Digital Filter Circuit.

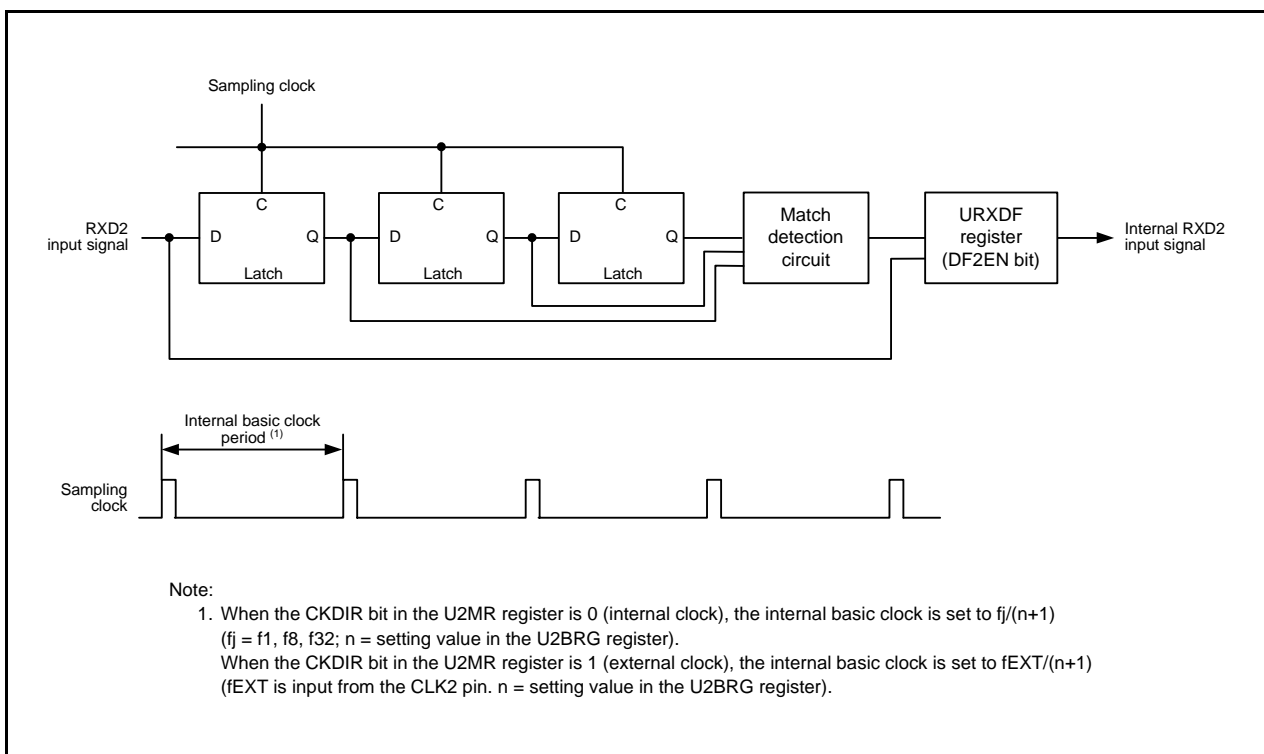

Figure 22.12 Block Diagram of RXD2 Digital Filter Circuit

22.5 Special Mode 1 (I²C Mode)

I²C mode is provided for use as a simplified I²C interface compatible mode. Table 22.9 lists the I²C Mode Specifications. Tables 22.10 and 22.11 list the registers used in I²C mode and the settings. Table 22.12 lists the I²C Mode Functions, Figure 22.13 shows an I²C Mode Block Diagram, and Figure 22.14 shows the Transfer to U2RB Register and Interrupt Timing.

As shown in Table 22.12, the MCU is placed in I²C mode by setting bits SMD2 to SMD0 to 010b and the IICM bit to 1. Because SDA2 transmit output has a delay circuit attached, SDA2 output does not change state until SCL2 goes low and remains stably low.

Table 22.9 I²C Mode Specifications

Item	Specification
Transfer data format	Transfer data length: 8 bits
Transfer clock	<ul style="list-style-type: none"> Master mode The CKDIR bit in the U2MR register is set to 0 (internal clock): $f_j/(2(n+1))$ $f_j = f_1, f_8, f_{32}$ $n =$ setting value in the U2BRG register: 00h to FFh Slave mode The CKDIR bit is set to 1 (external clock): Input from the SCL2 pin
Transmit start conditions	To start transmission, the following requirements must be met: ⁽¹⁾ <ul style="list-style-type: none"> The TE bit in the U2C1 register is set to 1 (transmission enabled). The TI bit in the U2C1 register is set to 0 (data present in the U2TB register).
Receive start conditions	To start reception, the following requirements must be met: ⁽¹⁾ <ul style="list-style-type: none"> The RE bit in the U2C1 register is set to 1 (reception enabled). The TE bit in the U2C1 register is set to 1 (transmission enabled). The TI bit in the U2C1 register is set to 0 (data present in the U2TB register).
Interrupt request generation timing	Start/stop condition detection, no acknowledgement detection, or acknowledgement detection
Error detection	Overrun error ⁽²⁾ This error occurs if the serial interface starts receiving the next unit of data before reading the U2RB register and receives the 8th bit of the next unit of data.
Selectable functions	<ul style="list-style-type: none"> SDA2 digital delay No digital delay or a delay of 2 to 8 U2BRG count source clock cycles can be selected. Clock phase setting With or without clock delay can be selected.

Notes:

- When an external clock is selected, the requirements must be met while the external clock is held high.
- If an overrun error occurs, the received data in the U2RB register will be undefined. The IR bit in the S2RIC register remains unchanged.

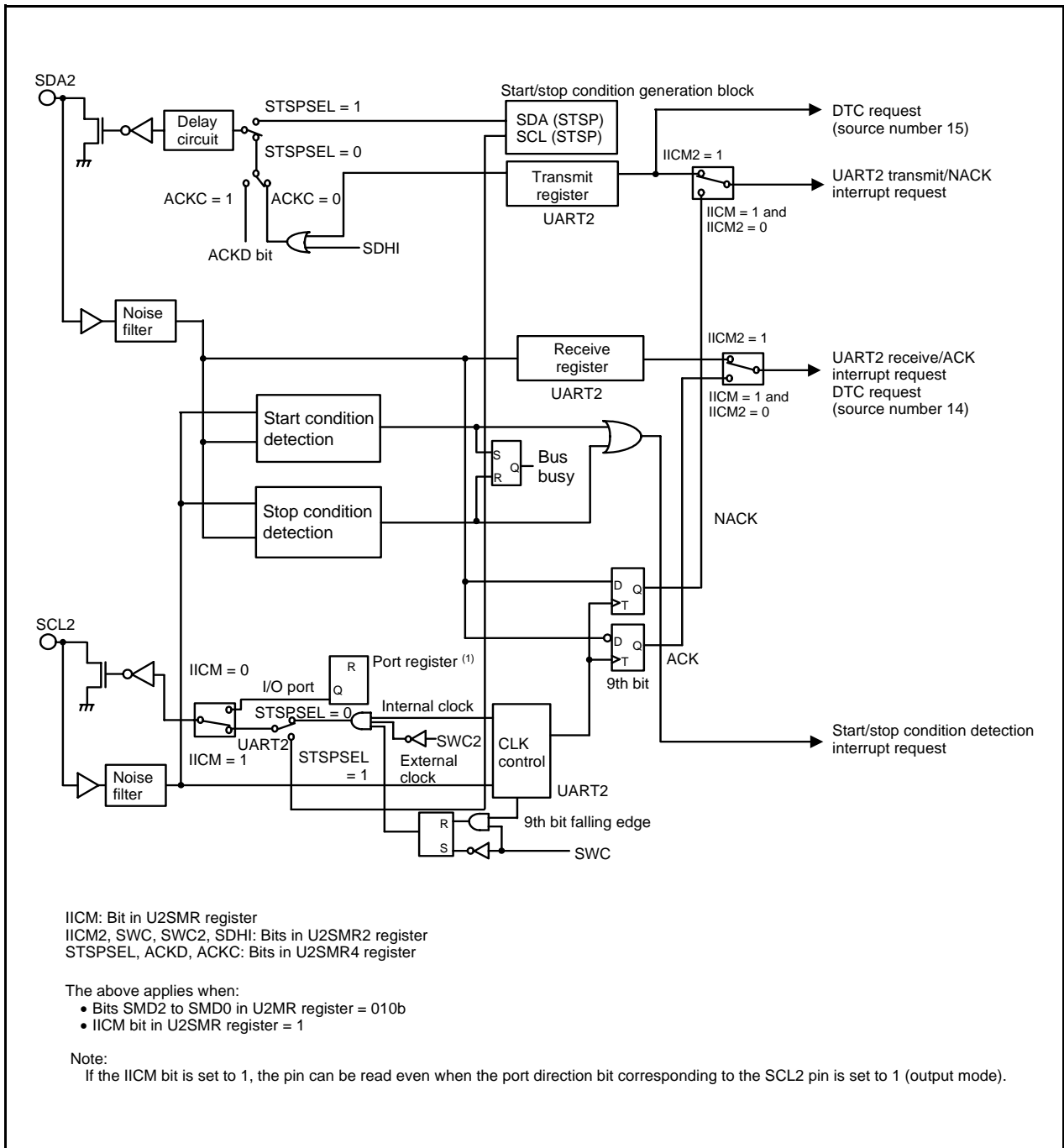

Figure 22.13 I²C Mode Block Diagram

Table 22.10 Registers Used and Settings in I²C Mode (1)

Register	Bit	Function	
		Master	Slave
U2TB (1)	b0 to b7	Set transmit data.	Set transmit data.
U2RB (1)	b0 to b7	Receive data can be read.	Receive data can be read.
	b8	ACK or NACK is set in this bit.	ACK or NACK is set in this bit.
	OER	Overrun error flag	Overrun error flag
U2BRG	b0 to b7	Set a bit rate.	Disabled
U2MR (1)	SMD2 to SMD0	Set to 010b.	Set to 010b.
	CKDIR	Set to 0.	Set to 1.
	IOPOL	Set to 0.	Set to 0.
U2C0	CLK1, CLK0	Select the count source for the U2BRG register.	Disabled
	CRS	Disabled because CRD = 1.	Disabled because CRD = 1.
	TXEPT	Transmit register empty flag	Transmit register empty flag
	CRD	Set to 1.	Set to 1.
	NCH	Set to 1.	Set to 1.
	CKPOL	Set to 0.	Set to 0.
	UFORM	Set to 1.	Set to 1.
U2C1	TE	Set to 1 to enable transmission.	Set to 1 to enable transmission.
	TI	Transmit buffer empty flag	Transmit buffer empty flag
	RE	Set to 1 to enable reception.	Set to 1 to enable reception.
	RI	Receive complete flag	Receive complete flag
	U2IRS	Set to 1.	Set to 1.
	U2RRM, U2LCH, U2ERE	Set to 0.	Set to 0.
U2SMR	IICM	Set to 1.	Set to 1.
	BBS	Bus busy flag	Bus busy flag
	b3 to b7	Set to 0.	Set to 0.
U2SMR2	IICM2	Refer to Table 22.12 I²C Mode Functions.	Refer to Table 22.12 I²C Mode Functions.
	CSC	Set to 1 to enable clock synchronization.	Set to 0.
	SWC	Set to 1 to fix SCL2 output low at the falling edge of the 9th bit of clock.	Set to 1 to fix SCL2 output low at the falling edge of the 9th bit of clock.
	STAC	Set to 0.	Set to 1 to initialize UART2 at start condition detection
	SWC2	Set to 1 to forcibly pull SCL2 low.	Set to 1 to forcibly pull SCL2 output low.
	SDHI	Set to 1 to disable SDA2 output.	Set to 1 to disable SDA2 output.
	b7	Set to 0.	Set to 0.

Note:

1. Set the bits not listed in this table to 0 when writing to the above registers in I²C mode.

Table 22.11 Registers Used and Settings in I²C Mode (2)

Register	Bit	Function	
		Master	Slave
U2SMR3	b0, b2, b4, and NODC	Set to 0.	Set to 0.
	CKPH	Refer to Table 22.12 I²C Mode Functions.	Refer to Table 22.12 I²C Mode Functions.
	DL2 to DL0	Set the amount of SDA2 digital delay.	Set the amount of SDA2 digital delay.
U2SMR4	STAREQ	Set to 1 to generate a start condition.	Set to 0.
	RSTAREQ	Set to 1 to generate a restart condition.	Set to 0.
	STPREQ	Set to 1 to generate a stop condition.	Set to 0.
	STSPSEL	Set to 1 to output each condition.	Set to 0.
	ACKD	Select ACK or NACK.	Select ACK or NACK.
	ACKC	Set to 1 to output ACK data.	Set to 1 to output ACK data.
	SCLHI	Set to 1 to stop SCL2 output when a stop condition is detected.	Set to 0.
	SWC9	Set to 0.	Set to 1 to hold SCL2 low at the falling edge of the 9th bit of clock.
URXDF	DF2EN	Set to 0.	Set to 0.
U2SMR5	MP	Set to 0.	Set to 0.

Table 22.12 I²C Mode Functions

Function	Clock Synchronous Serial I/O Mode (SMD2 to SMD0 = 001b, IICM = 0)	I ² C Mode (SMD2 to SMD0 = 010b, IICM = 1)			
		IICM2 = 0 (NACK/ACK interrupt)		IICM2 = 1 (UART transmit/receive interrupt)	
		CKPH = 0 (No Clock Delay)	CKPH = 1 (With Clock Delay)	CKPH = 0 (No Clock Delay)	CKPH = 1 (With Clock Delay)
Source of UART2 bus collision interrupt (1, 5)	-	Start condition detection or stop condition detection (Refer to Table 22.13 STSPSEL Bit Functions)			
Source of UART2 transmit/NACK2 (1, 6)	UART2 transmission Transmission started or completed (selectable by U2IRS bit)	No acknowledgment detection (NACK) Rising edge of SCL2 9th bit		UART2 transmission Rising edge of SCL2 9th bit	UART2 transmission Falling edge of SCL2 next to 9th bit
Source of UART2 receive/ACK2 (1, 6)	UART2 reception When 8th bit received CKPOL = 0 (rising edge) CKPOL = 1 (falling edge)	Acknowledgment detection (ACK) Rising edge of SCL2 9th bit		UART2 reception Falling edge of SCL2 9th bit	
Timing for transferring data from UART reception shift register to U2RB register	CKPOL = 0 (rising edge) CKPOL = 1 (falling edge)	Rising edge of SCL2 9th bit		Falling edge of SCL2 9th bit	Falling and rising edges of SCL2 9th bit
UART2 transmission output delay	No delay	With delay			
TXD2/SDA2 functions	TXD2 output	SDA2 I/O			
RXD2/SCL2 functions	RXD2 input	SCL2 I/O			
CLK2 functions	CLK2 input or output port selected	– (Cannot be used in I ² C mode.)			
Noise filter width	15 ns	200 ns			
Read of RXD2 and SCL2 pin levels	Possible when the corresponding port direction bit = 0	Possible regardless of the content of the corresponding port direction bit.			
Initial value of TXD2 and SDA2 outputs	CKPOL = 0 ("H") CKPOL = 1 ("L")	The value set in the port register before setting I ² C mode. (2)			
Initial and end values of SCL2	-	"H"	"L"	"H"	"L"
DTC source number 14 (6)	UART2 reception When 8th bit received CKPOL = 0 (rising edge) CKPOL = 1 (falling edge)	Acknowledgment detection (ACK)		UART2 reception Falling edge of SCL2 9th bit	
DTC source number 15 (6)	UART2 transmission Transmission started or completed (selectable by U2IRS bit)	UART2 transmission Rising edge of SCL2 9th bit	UART2 transmission Falling edge of SCL2 next to 9th bit	UART2 transmission Rising edge of SCL2 9th bit	UART2 transmission Falling edge of SCL2 next to 9th bit
Storage of receive data	1st to 8th bits of the received data are stored in bits b0 to b7 in the U2RB register.	1st to 8th bits of the received data are stored in bits b7 to b0 in the U2RB register.		1st to 7th bits of the received data are stored in bits b6 to b0 in the U2RB register. 8th bit is stored in bit b8 in the U2RB register. 1st to 8th bits are stored in bits b7 to b0 in the U2RB register. (3)	
Read of receive data	The U2RB register status is read.				Bits b6 to b0 in the U2RB register are read as bits b7 to b1. Bit b8 in the U2RB register is read as bit b0. (4)

Notes:

- If the source of any interrupt is changed, the IR bit in the interrupt control register for the changed interrupt may inadvertently be set to 1 (interrupt requested). (Refer to 11.8 Notes on Interrupts.)
If one of the bits listed below is changed, the interrupt source, the interrupt timing, and others change. Therefore, always be sure to set the IR bit to 0 (interrupt not requested) after changing these bits.
Bits SMD2 to SMD0 in the U2MR register, the IICM bit in the U2SMR register, the IICM2 bit in the U2SMR2 register, and the CKPH bit in the U2SMR3 register.
- Set the initial value of SDA2 output while bits SMD2 to SMD0 in the U2MR register are 000b (serial interface disabled).
- Second data transfer to the U2RB register (rising edge of SCL2 9th bit)
- First data transfer to the U2RB register (falling edge of SCL2 9th bit)
- Refer to Figure 22.16 STSPSEL Bit Functions.
- Refer to Figure 22.14 Transfer to U2RB Register and Interrupt Timing.

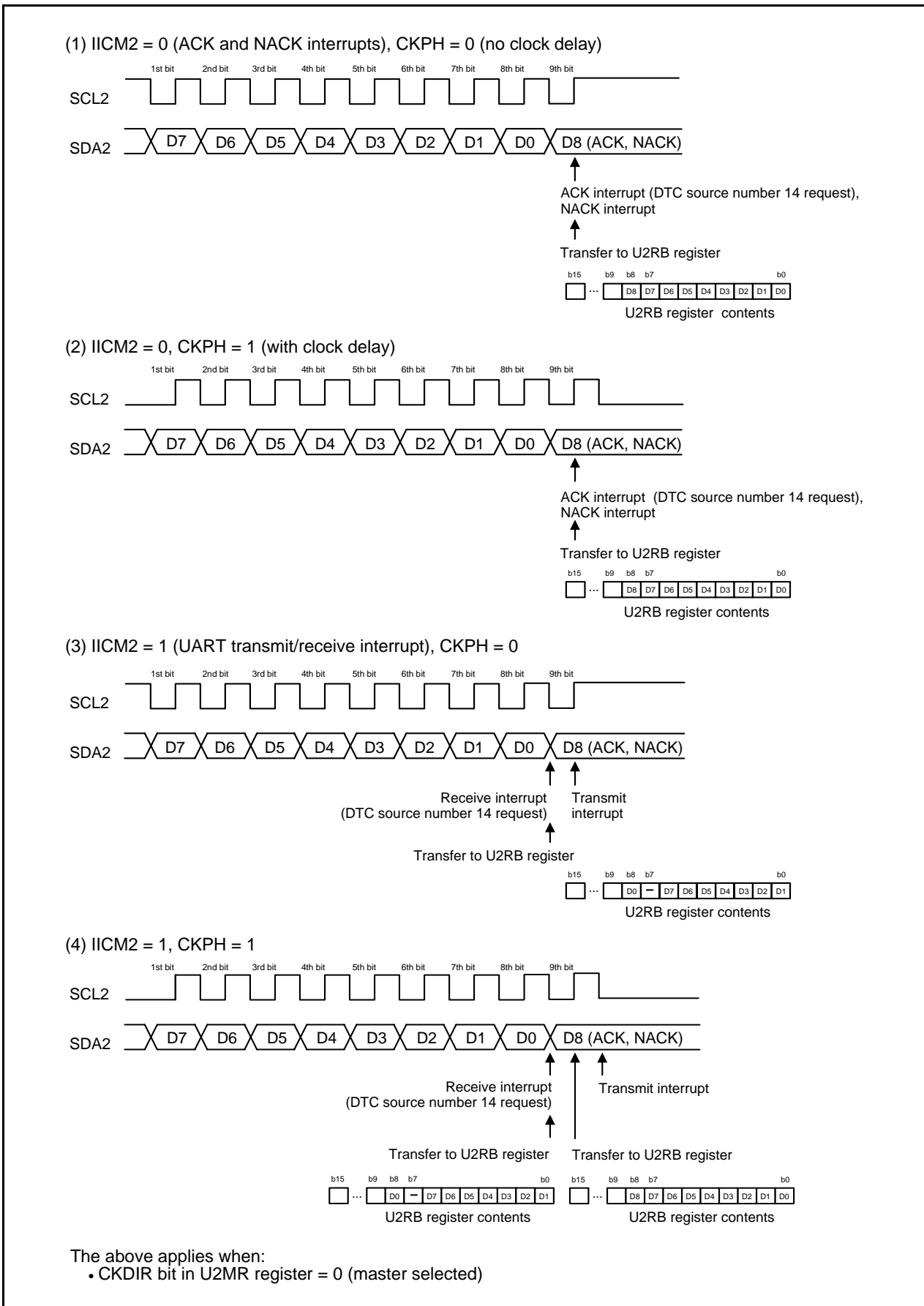

Figure 22.14 Transfer to U2RB Register and Interrupt Timing

22.5.1 Detection of Start and Stop Conditions

Whether a start or a stop condition has been detected is determined. A start condition detect interrupt request is generated when the SDA2 pin changes state from high to low while the SCL2 pin is in the high state. A stop condition detect interrupt request is generated when the SDA2 pin changes state from low to high while the SCL2 pin is in the high state. Because the start and stop condition detect interrupts share an interrupt control register and vector, check the BBS bit in the U2SMR register to determine which interrupt source is requesting the interrupt. Figure 22.15 shows the Detection of Start and Stop Conditions.

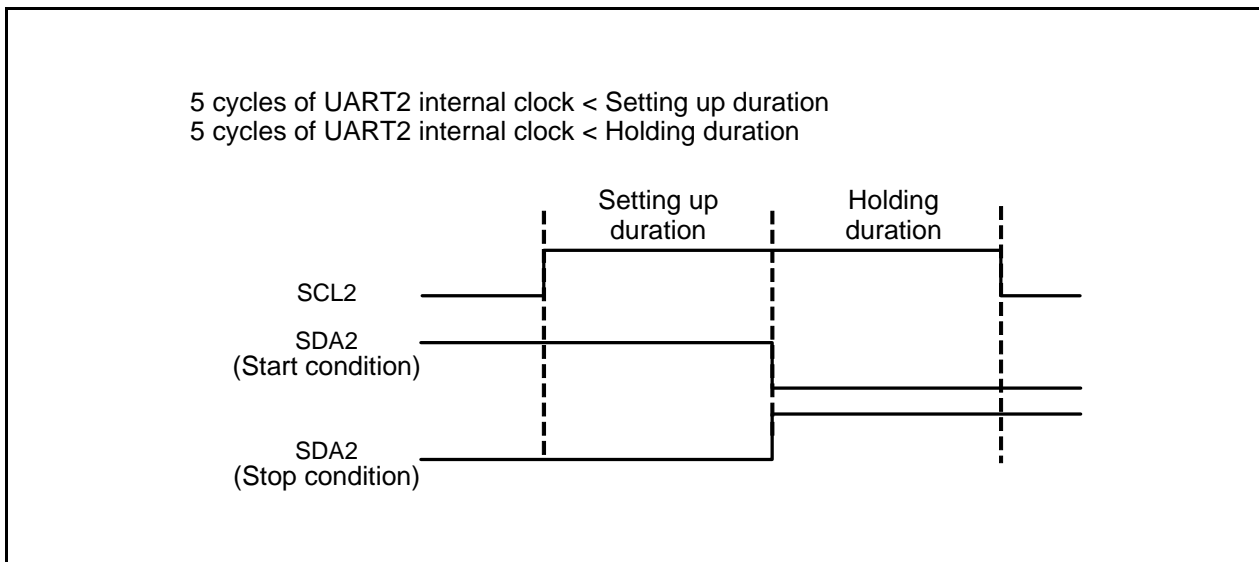

Figure 22.15 Detection of Start and Stop Conditions

22.5.2 Output of Start and Stop Conditions

A start condition is generated by setting the STAREQ bit in the U2SMR4 register to 1 (start).

A restart condition is generated by setting the RSTAREQ bit in the U2SMR4 register to 1 (start).

A stop condition is generated by setting the STPREQ bit in the U2SMR4 register to 1 (start).

The output procedure is as follows:

(1) Set the STAREQ bit, RSTAREQ bit or STPREQ bit to 1 (start).

(2) Set the STSPSEL bit in the U2SMR4 register to 1 (output).

Table 22.13 lists the STSPSEL Bit Functions. Figure 22.16 shows the STSPSEL Bit Functions.

Table 22.13 STSPSEL Bit Functions

Function	STSPSEL = 0	STSPSEL = 1
Output of pins SCL2 and SDA2	Output of transfer clock and data Output of start/stop conditions is accomplished by a program using ports (not automatically generated in hardware)	Output of start/stop conditions according to bits STAREQ, RSTAREQ, and STPREQ
Start/stop condition interrupt request generation timing	Detection of start/stop conditions	Completion of start/stop condition generation

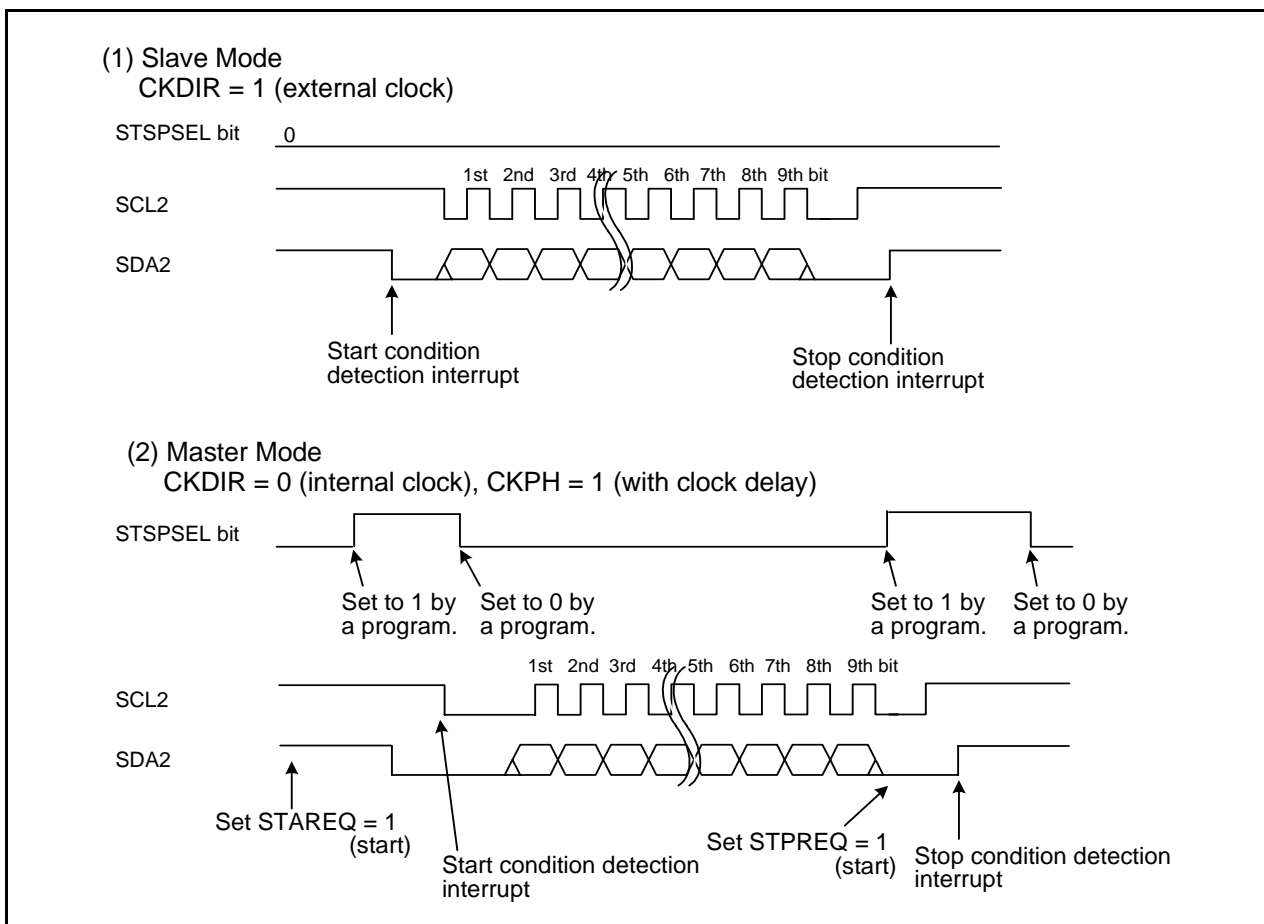

Figure 22.16 STSPSEL Bit Functions

22.5.3 Transfer Clock

The transfer clock is used to transmit and receive data as is shown in **Figure 22.14 Transfer to U2RB Register and Interrupt Timing**.

The CSC bit in the U2SMR2 register is used to synchronize an internally generated clock (internal SCL2) and an external clock supplied to the SCL2 pin. When the CSC bit is set to 1 (clock synchronization enabled), if a falling edge on the SCL2 pin is detected while the internal SCL2 is high, the internal SCL2 goes low. The value in the U2BRG register is reloaded and counting of the low-level intervals starts. If the internal SCL2 changes state from low to high while the SCL2 pin is low, counting stops. If the SCL2 pin goes high, counting restarts. In this way, the UART2 transfer clock is equivalent to AND of the internal SCL2 and the clock signal applied to the SCL2 pin. The transfer clock works from a half cycle before the falling edge of the internal SCL2 1st bit to the rising edge of the 9th bit. To use this function, select an internal clock for the transfer clock.

The SWC bit in the U2SMR2 register determines whether the SCL2 pin is fixed low or freed from low-level output at the falling edge of the 9th clock pulse.

If the SCLHI bit in the U2SMR4 register is set to 1 (enabled), SCL2 output is turned off (placed in the high-impedance state) when a stop condition is detected.

Setting the SWC2 bit in the U2SMR2 register to 1 (“L” output) makes it possible to forcibly output a low-level signal from the SCL2 pin even while sending or receiving data. Setting the SWC2 bit to 0 (transfer clock) allows the transfer clock to be output from or supplied to the SCL2 pin, instead of outputting a low-level signal. If the SWC9 bit in the U2SMR4 register is set to 1 (SCL “L” hold enabled) when the CKPH bit in the U2SMR3 register is 1, the SCL2 pin is fixed low at the falling edge of the clock pulse next to the 9th. Setting the SWC9 bit to 0 (SCL “L” hold disabled) frees the SCL2 pin from low-level output.

22.5.4 SDA Output

The data written to bits b7 to b0 (D7 to D0) in the U2TB register is output in descending order from D7.

The 9th bit (D8) is ACK or NACK.

Set the initial value of SDA2 transmit output when IICM is set to 1 (I²C mode) and bits SMD2 to SMD0 in the U2MR register are set to 000b (serial interface disabled).

Bits DL2 to DL0 in the U2SMR3 register allow addition of no delays or a delay of 2 to 8 U2BRG count source clock cycles to the SDA2 output.

Setting the SDHI bit in the U2SMR2 register to 1 (SDA output disabled) forcibly places the SDA2 pin in the high-impedance state. Do not write to the SDHI bit at the rising edge of the UART2 transfer clock.

22.5.5 SDA Input

When the IICM2 bit is set to 0, the 1st to 8th bits (D7 to D0) of received data are stored in bits b7 to b0 in the U2RB register. The 9th bit (D8) is ACK or NACK.

When the IICM2 bit is set to 1, the 1st to 7th bits (D7 to D1) of received data are stored in bits b6 to b0 in the U2RB register and the 8th bit (D0) is stored in bit b8 in the U2RB register. Even when the IICM2 bit is set to 1, if the CKPH bit is 1, the same data as when the IICM2 bit is 0 can be read by reading the U2RB register after the rising edge of 9th bit of the clock.

22.5.6 ACK and NACK

If the STSPSEL bit in the U2SMR4 register is set to 0 (start and stop conditions not output) and the ACKC bit in the U2SMR4 register is set to 1 (ACK data output), the value of the ACKD bit in the U2SMR4 register is output from the SDA2 pin.

If the IICM2 bit is set to 0, a NACK interrupt request is generated if the SDA2 pin remains high at the rising edge of the 9th bit of transmit clock pulse. An ACK interrupt request is generated if the SDA2 pin is low at the rising edge of the 9th bit of the transmit clock.

If ACK2 (UART2 reception) is selected to generate a DTC request source, a DTC transfer can be activated by detection of an acknowledge.

22.5.7 Initialization of Transmission/Reception

If a start condition is detected while the STAC bit is set to 1 (UART2 initialization enabled), the serial interface operates as described below.

- The transmit shift register is initialized, and the contents of the U2TB register are transferred to the transmit shift register. In this way, the serial interface starts sending data when the next clock pulse is applied. However, the UART2 output value does not change state and remains the same as when a start condition was detected until the first bit of data is output in synchronization with the input clock.
- The receive shift register is initialized, and the serial interface starts receiving data when the next clock pulse is applied.
- The SWC bit is set to 1 (SCL wait output enabled). Consequently, the SCL2 pin is pulled low at the falling edge of the 9th clock pulse.

Note that when UART2 transmission/reception is started using this function, the TI bit does not change state. Select the external clock as the transfer clock to start UART2 transmission/reception with this setting.

22.6 Special Mode 3 (IE mode)

In IE mode, one bit of IEBus is approximated with one byte of UART mode waveform.

Table 22.14 lists the Registers Used and Settings in IE Mode. Figure 22.17 shows the Bits Associated with Bus Collision Detect Function.

If the TXD2 pin output level and RXD2 pin input level do not match, a UART2 bus collision detect interrupt request is generated.

Table 22.14 Registers Used and Settings in IE Mode

Register	Bit	Function
U2TB	b0 to b8	Set transmit data.
U2RB (1)	b0 to b8	Receive data can be read.
	OER, FER, PER, SUM	Error flag
U2BRG	b0 to b7	Set a bit rate.
U2MR	SMD2 to SMD0	Set to 110b.
	CKDIR	Select the internal clock or external clock.
	STPS	Set to 0.
	PRY	Disabled because PRYE = 0.
	PRYE	Set to 0.
	IOPOL	Select the TXD and RXD I/O polarity
U2C0	CLK1, CLK0	Select the count source for the U2BRG register.
	CRS	Disabled because CRD = 1.
	TXEPT	Transmit register empty flag
	CRD	Set to 1.
	NCH	Select the TXD2 pin output format.
	CKPOL	Set to 0.
	UFORM	Set to 0.
U2C1	TE	Set to 1 to enable transmission.
	TI	Transmit buffer empty flag
	RE	Set to 1 to enable reception.
	RI	Receive complete flag
	U2IRS	Select the UART2 transmit interrupt source.
	U2RRM, U2LCH, U2ERE	Set to 0.
U2SMR	b0 to b3, b7	Set to 0.
	ABSCS	Select the sampling timing at which a bus collision is detected.
	ACSE	Set to 1 to use the auto clear function of the transmit enable bit.
	SSS	Select the transmit start condition.
U2SMR2	b0 to b7	Set to 0.
U2SMR3	b0 to b7	Set to 0.
U2SMR4	b0 to b7	Set to 0.
URXDF	DF2EN	Set to 0.
U2SMR5	MP	Set to 0.

Note:

1. Set the bits not listed in this table to 0 when writing to the above registers in IE mode.

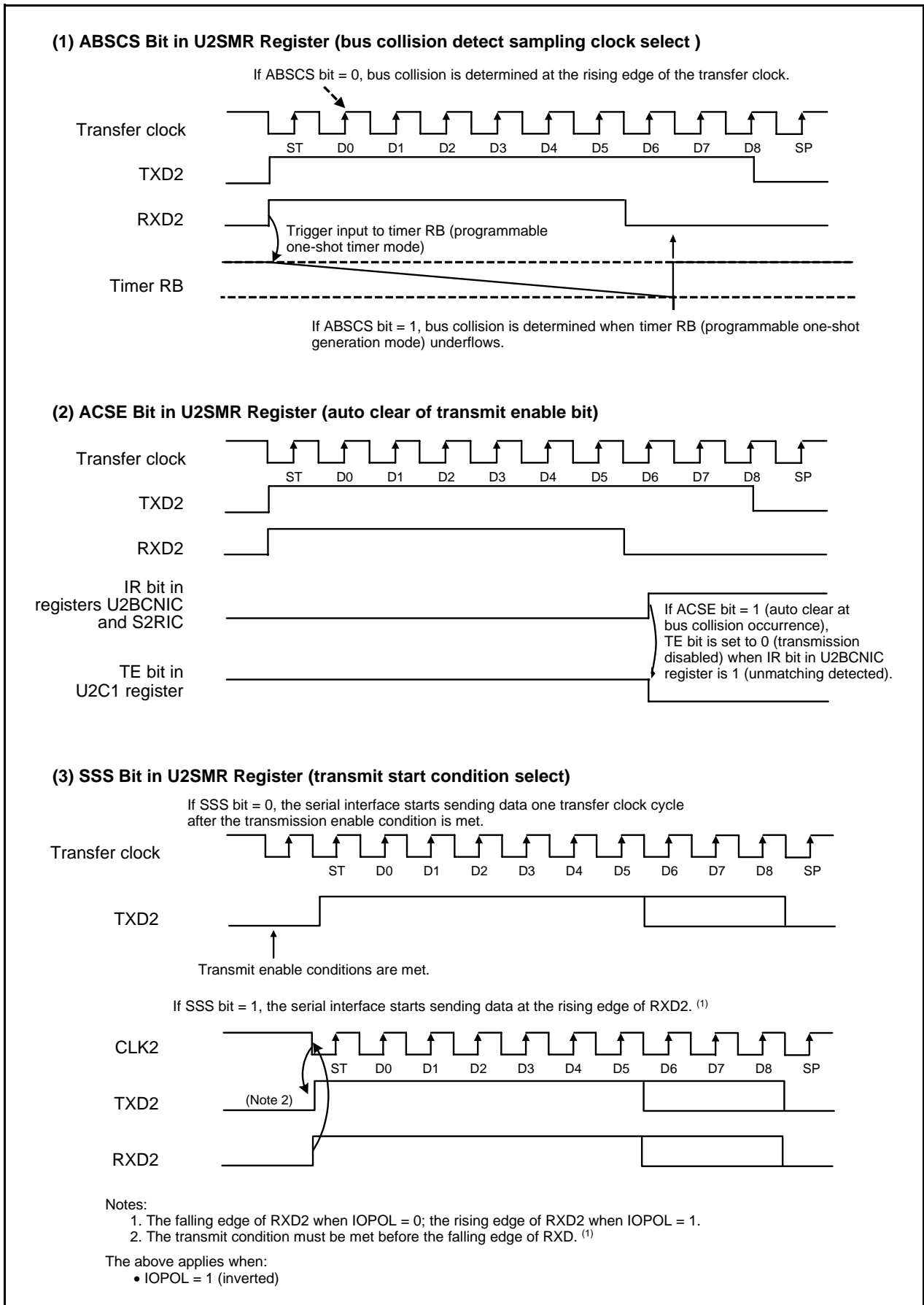

Figure 22.17 Bits Associated with Bus Collision Detect Function

22.7 Multiprocessor Communication Function

When the multiprocessor communication function is used, data transmission/reception can be performed between a number of processors sharing communication lines by asynchronous serial communication, in which a multiprocessor bit is added to the data. For multiprocessor communication, each receiving station is addressed by a unique ID code. The serial communication cycle consists of two component cycles; an ID transmission cycle for specifying the receiving station, and a data transmission cycle for the specified receiving station. The multiprocessor bit is used to differentiate between the ID transmission cycle and the data transmission cycle. When the multiprocessor bit is set to 1, the cycle is an ID transmission cycle; when the multiprocessor bit is set to 0, the cycle is a data transmission cycle. Figure 22.18 shows an Inter-Processor Communication Example Using Multiprocessor Format (Data AAh Transmission to Receiving Station A).

The transmitting station first sends the ID code of the receiving station to perform communication as communication data with a 1 multiprocessor bit added. It then sends transmit data as communication data with a 0 multiprocessor bit added.

When communication data in which the multiprocessor bit is 1 is received, the receiving station compares that data with its own ID. If they match, the data to be sent next is received. If they do not match, the receive station continues to skip communication data until data in which the multiprocessor bit is 1 is again received.

UART2 uses the MPIE bit in the U2SMR5 register to implement this function. When the MPIE bit is set to 1, data transfer from the UART2 receive register to the U2RB register, receive error detection, and the settings of the status flags, the RI bit in the U2C1 register, bits FER and OER in the U2RB register, are disabled until data in which the multiprocessor bit is 1 is received. On receiving a receive character in which the multiprocessor bit is 1, the MPRB bit in the U2RB register is set to 1 and the MPIE in the U2SMR5 register bit is set to 0, thus normal reception is resumed.

When the multiprocessor format is specified, the parity bit specification is invalid. All other bit settings are the same as those in normal asynchronous mode (UART mode). The clock used for multiprocessor communication is the same as that in normal asynchronous mode (UART mode).

Figure 22.19 shows a Block Diagram of Multiprocessor Communication Function.

Table 22.15 lists the Registers and Settings in Multiprocessor Communication Function.

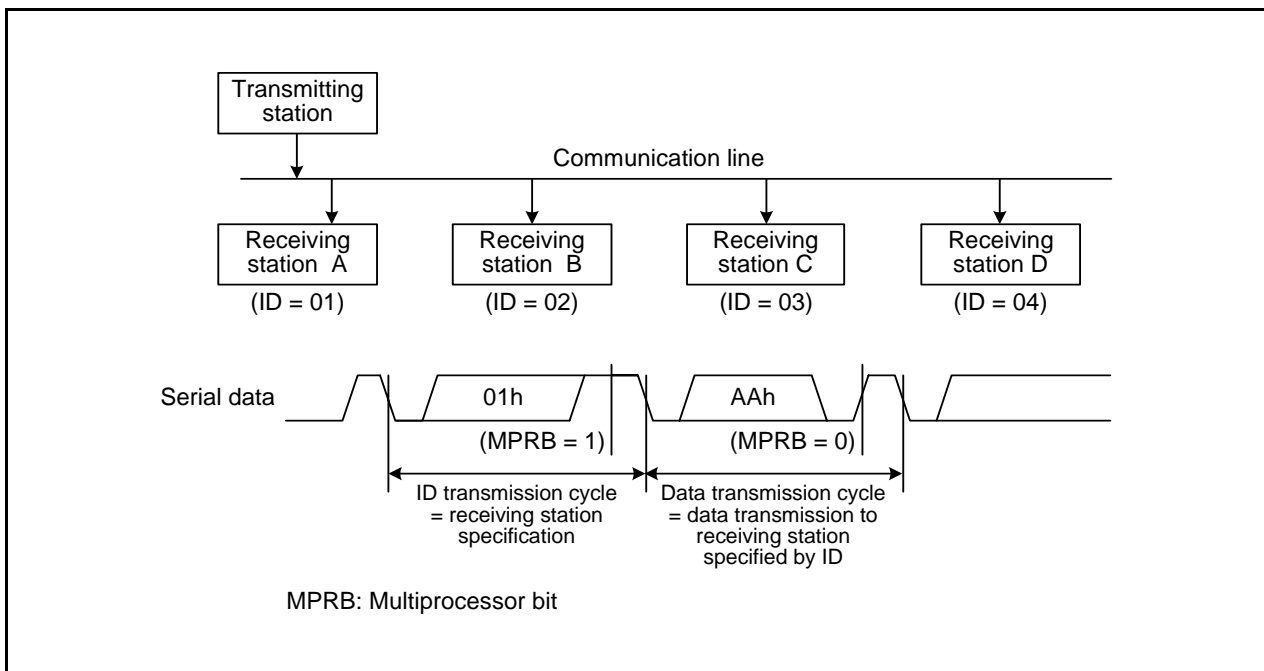

Figure 22.18 Inter-Processor Communication Example Using Multiprocessor Format (Data AAh Transmission to Receiving Station A)

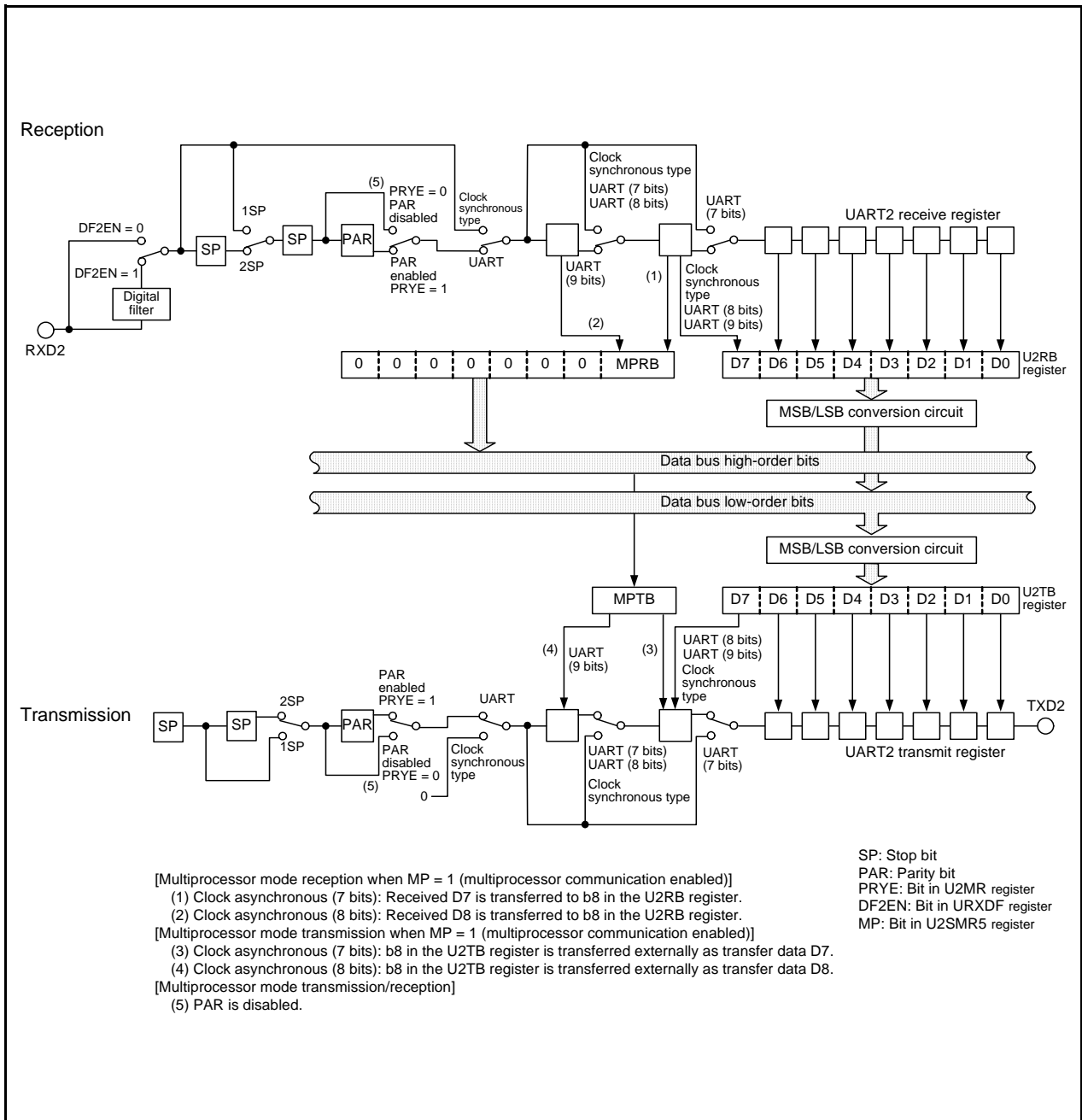

Figure 22.19 Block Diagram of Multiprocessor Communication Function

Table 22.15 Registers and Settings in Multiprocessor Communication Function

Register	Bit	Function
U2TB (1)	b0 to b7	Set transmit data.
	MPTB	Set to 0 or 1.
U2RB (2)	b0 to b7	Receive data can be read.
	MPRB	Multiprocessor bit
	OER, FER, SUM	Error flag
U2BRG	b0 to b7	Set the transfer rate.
U2MR	SMD2 to SMD0	Set to 100b when transfer data is 7 bits long.
		Set to 101b when transfer data is 8 bits long.
	CKDIR	Select the internal clock or external clock.
	STPS	Select the stop bit.
	PRY, PRYE	Parity detection function disabled
	IOPOL	Set to 0.
U2C0	CLK0, CLK1	Select the U2BRG count source.
	CRS	$\overline{\text{CTS}}$ or $\overline{\text{RTS}}$ function disabled
	TXEPT	Transmit register empty flag
	CRD	Set to 0.
	NCH	Select TXD2 pin output mode.
	CKPOL	Set to 0.
	UFORM	Set to 0.
U2C1	TE	Set to 1 to enable transmission.
	TI	Transmit buffer empty flag
	RE	Set to 1 to enable reception.
	RI	Receive complete flag
	U2IRS	Select the UART2 transmit interrupt source.
	U2LCH	Set to 0.
	U2ERE	Set to 0.
U2SMR	b0 to b7	Set to 0.
U2SMR2	b0 to b7	Set to 0.
U2SMR3	b0 to b7	Set to 0.
U2SMR4	b0 to b7	Set to 0.
U2SMR5	MP	Set to 1.
	MPIE	Set to 1.
URXDF	DF2EN	Select the digital filter enabled or disabled.

Notes:

1. Set the MPTB bit to 1 when the ID data frame is transmitted. Set this bit to 0 when the data frame is transmitted.
2. If the MPRB bit is set to 1, received D7 to D0 are ID fields. If the MPRB bit is set to 0, received D7 to D0 are data fields.

22.7.1 Multiprocessor Transmission

Figure 22.20 shows a Sample Flowchart of Multiprocessor Data Transmission. Set the MPTB bit in the U2TB register to 1 for ID transmission cycles. Set the MPTB bit in the U2TB register to 0 for data transmission cycles. Other operations are the same as in universal asynchronous receiver/transmitter mode (UART mode).

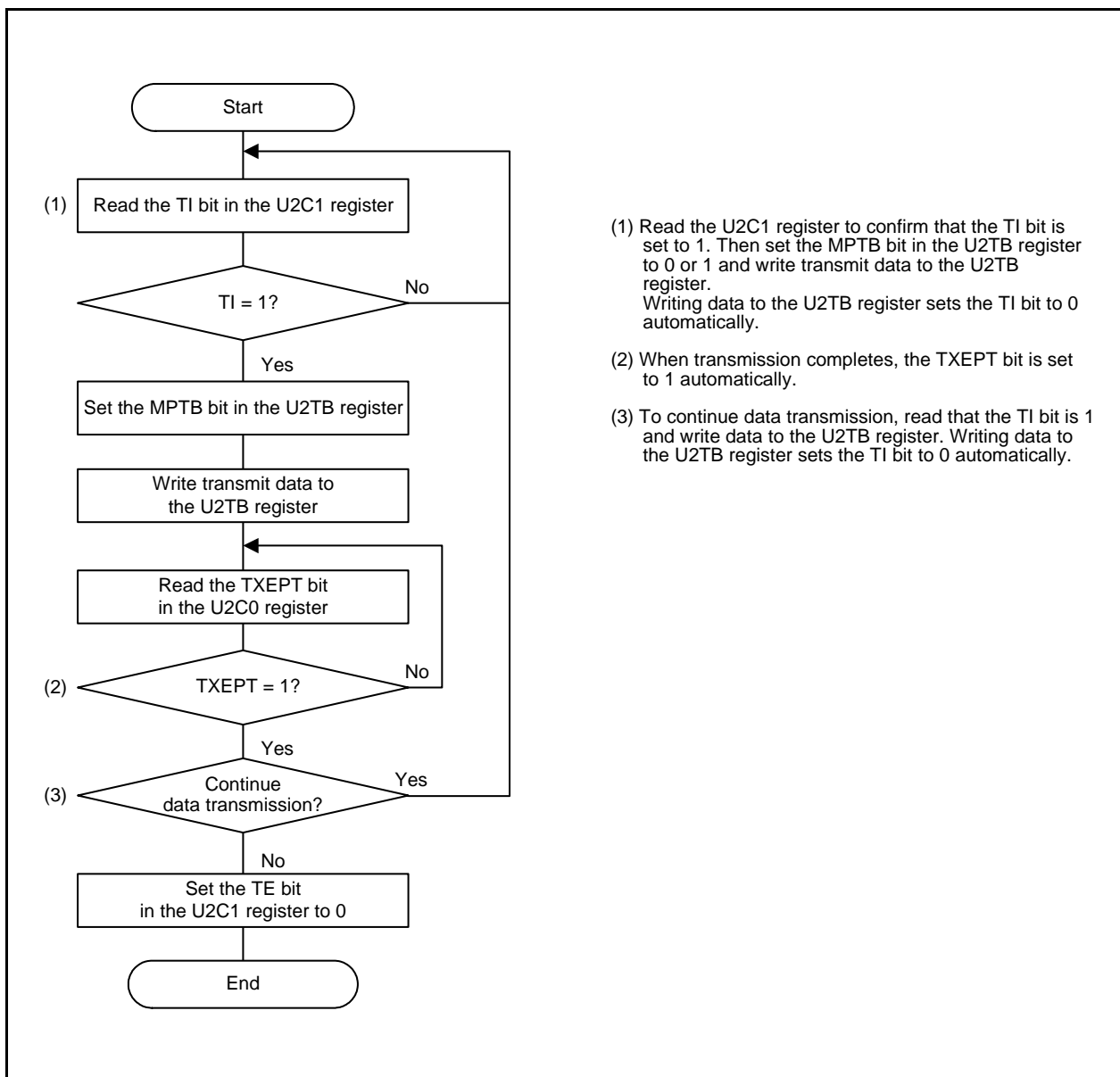

- (1) Read the U2C1 register to confirm that the TI bit is set to 1. Then set the MPTB bit in the U2TB register to 0 or 1 and write transmit data to the U2TB register. Writing data to the U2TB register sets the TI bit to 0 automatically.
- (2) When transmission completes, the TXEPT bit is set to 1 automatically.
- (3) To continue data transmission, read that the TI bit is 1 and write data to the U2TB register. Writing data to the U2TB register sets the TI bit to 0 automatically.

Figure 22.20 Sample Flowchart of Multiprocessor Data Transmission

22.7.2 Multiprocessor Reception

Figure 22.21 shows a Sample Flowchart of Multiprocessor Data Reception. When the MPIE bit in the U2SMR5 register is set to 1, communication data is ignored until data in which the multiprocessor bit is 1 is received. Communication data with a 1 multiprocessor bit added is transferred to the U2RB register as receive data. At this time, a reception complete interrupt request is generated. Other operations are the same as in universal asynchronous receiver/transmitter mode (UART mode). Figure 22.22 shows a Receive Operation Example during Multiprocessor Communication (with 8-Bit Data/Multiprocessor Bit/One-Stop Bit).

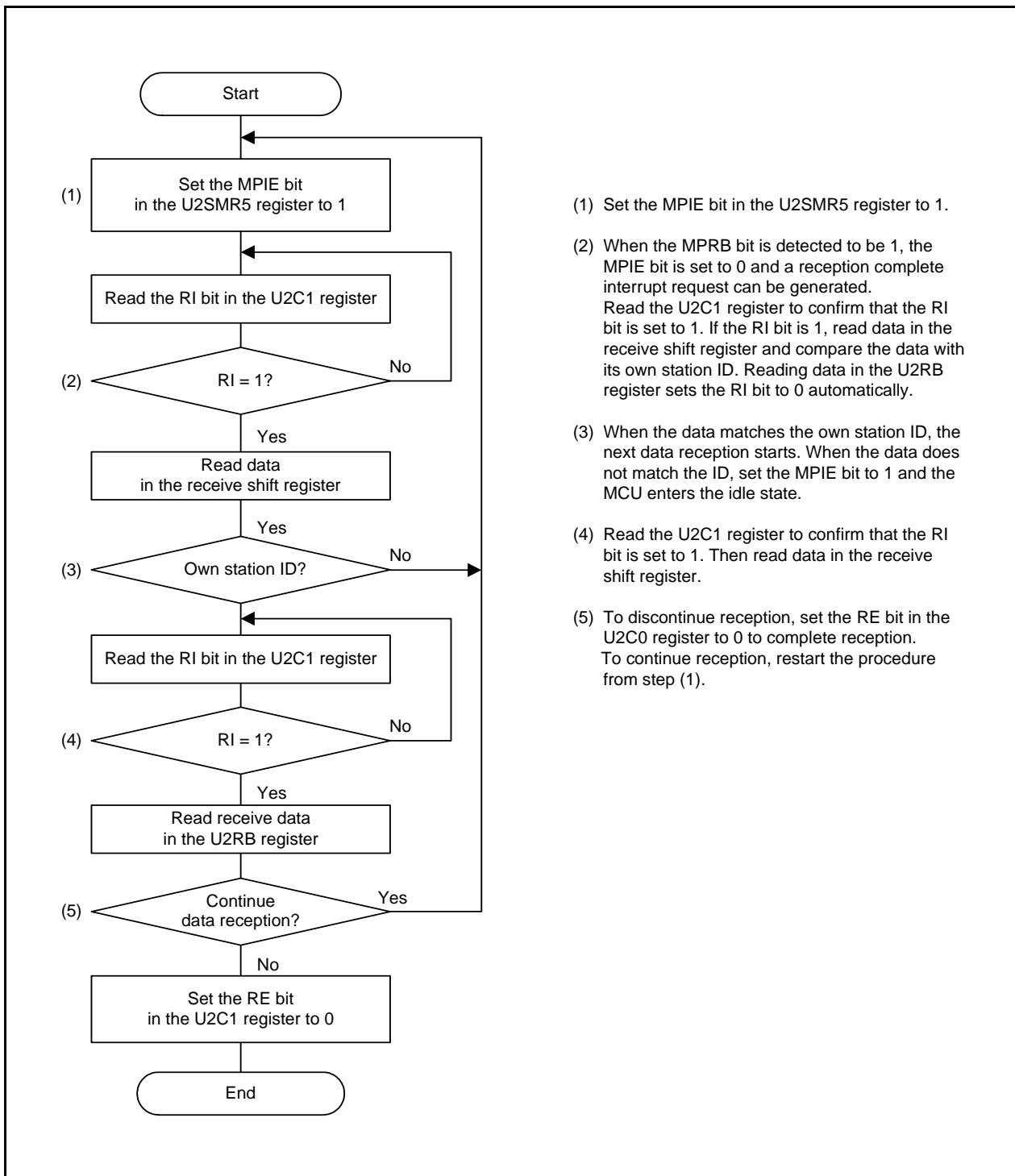

- (1) Set the MPIE bit in the U2SMR5 register to 1.
- (2) When the MPRB bit is detected to be 1, the MPIE bit is set to 0 and a reception complete interrupt request can be generated. Read the U2C1 register to confirm that the RI bit is set to 1. If the RI bit is 1, read data in the receive shift register and compare the data with its own station ID. Reading data in the U2RB register sets the RI bit to 0 automatically.
- (3) When the data matches the own station ID, the next data reception starts. When the data does not match the ID, set the MPIE bit to 1 and the MCU enters the idle state.
- (4) Read the U2C1 register to confirm that the RI bit is set to 1. Then read data in the receive shift register.
- (5) To discontinue reception, set the RE bit in the U2C0 register to 0 to complete reception. To continue reception, restart the procedure from step (1).

Figure 22.21 Sample Flowchart of Multiprocessor Data Reception

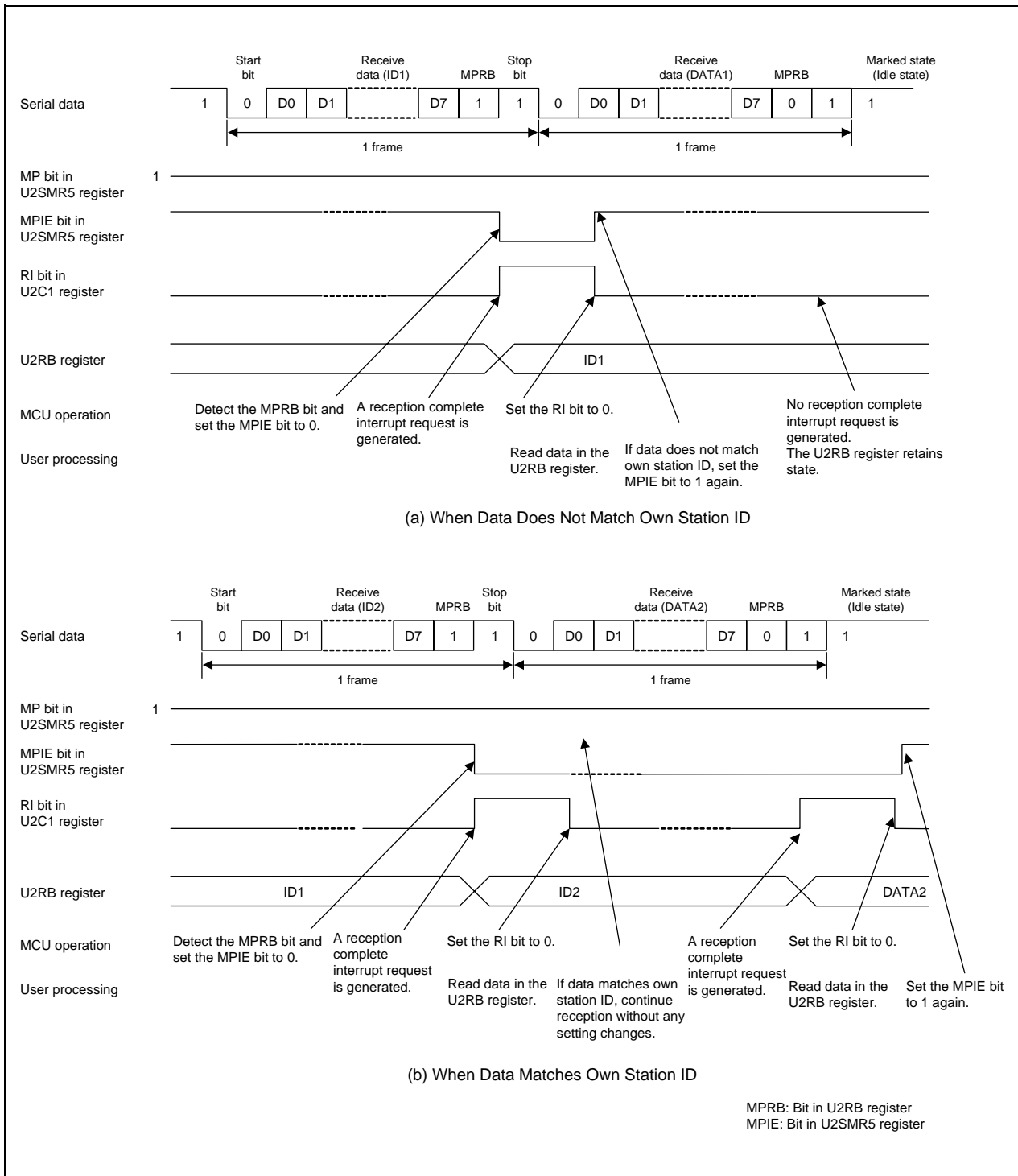

Figure 22.22 Receive Operation Example during Multiprocessor Communication (with 8-Bit Data/Multiprocessor Bit/One-Stop Bit)

22.7.3 RXD2 Digital Filter Select Function

When the DF2EN bit in the URXDF register is set to 1 (RXD2 digital filter enabled), the RXD2 input signal is loaded internally via the digital filter circuit for noise reduction. The noise canceller consists of three cascaded latch circuits and a match detection circuit. The RXD2 input signal is sampled on the internal basic clock with a frequency 16 times the bit rate. It is recognized as a signal and the level is passed forward to the next circuit when three latch outputs match. When the outputs do not match, the previous value is retained.

In other words, when the level is changed within three clocks, the change is recognized as not a signal but noise. Figure 22.23 shows a Block Diagram of RXD2 Digital Filter Circuit.

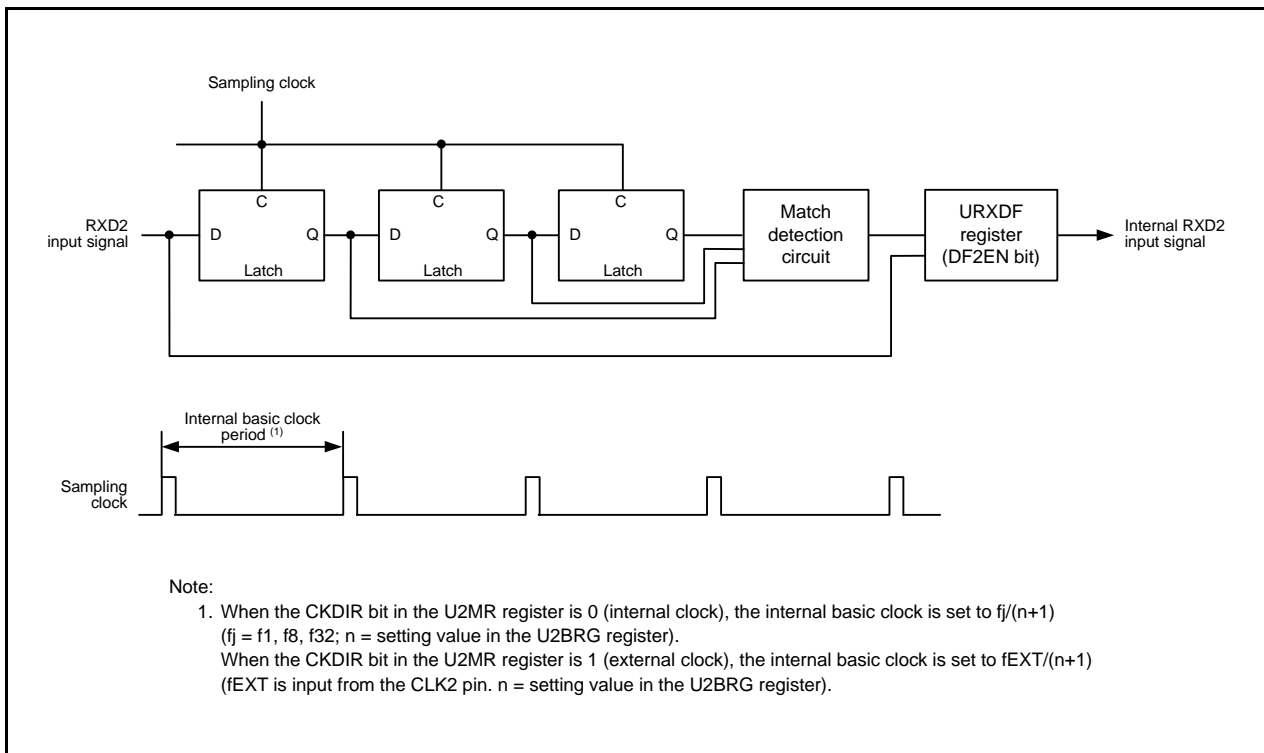

Figure 22.23 Block Diagram of RXD2 Digital Filter Circuit

22.8 Notes on Serial Interface (UART2)

22.8.1 Clock Synchronous Serial I/O Mode

22.8.1.1 Transmission/Reception

When the $\overline{\text{RTS}}$ function is used with an external clock, the $\overline{\text{RTS2}}$ pin outputs “L,” which informs the transmitting side that the MCU is ready for a receive operation. The $\overline{\text{RTS2}}$ pin outputs “H” when a receive operation starts. Therefore, the transmit timing and receive timing can be synchronized by connecting the $\overline{\text{RTS2}}$ pin to the $\overline{\text{CTS2}}$ pin of the transmitting side. The $\overline{\text{RTS}}$ function is disabled when an internal clock is selected.

22.8.1.2 Transmission

If an external clock is selected, the following conditions must be met while the external clock is held high when the CKPOL bit in the U2C0 register is set to 0 (transmit data output at the falling edge and receive data input at the rising edge of the transfer clock), or while the external clock is held low when the CKPOL bit is set to 1 (transmit data output at the rising edge and receive data input at the falling edge of the transfer clock).

- The TE bit in the U2C1 register = 1 (transmission enabled)
- The TI bit in the U2C1 register = 0 (data present in the U2TB register)
- If the $\overline{\text{CTS}}$ function is selected, input on the $\overline{\text{CTS2}}$ pin = “L”

22.8.1.3 Reception

In clock synchronous serial I/O mode, the shift clock is generated by activating the transmitter. Set the UART2-associated registers for transmit operation even if the MCU is used for receive operation only. Dummy data is output from the TXD2 pin while receiving.

When an internal clock is selected, the shift clock is generated by setting the TE bit in the U2C1 register to 1 (transmission enabled) and placing dummy data in the U2TB register. When an external clock is selected, set the TE bit to 1 (transmission enabled), place dummy data in the U2TB register, and input an external clock to the CLK2 pin to generate the shift clock.

If data is received consecutively, an overrun error occurs when the RE bit in the U2C1 register is set to 1 (data present in the U2RB register) and the next receive data is received in the UART2 receive register. Then, the OER bit in the U2RB register is set to 1 (overrun error). At this time, the U2RB register value is undefined. If an overrun error occurs, the IR bit in the S2RIC register remains unchanged.

To receive data consecutively, set dummy data in the low-order byte in the U2TB register per each receive operation.

If an external clock is selected, the following conditions must be met while the external clock is held high when the CKPOL bit is set to 0, or while the external clock is held low when the CKPOL bit is set to 1.

- The RE bit in the U2C1 register = 1 (reception enabled)
- The TE bit in the U2C1 register = 1 (transmission enabled)
- The TI bit in the U2C1 register = 0 (data present in the U2TB register)

22.8.2 Special Mode 1 (I²C Mode)

When generating start, stop, and restart conditions, set the STSPSEL bit in the U2SMR4 register to 0 and wait for more than half cycle of the transfer clock before changing each condition generation bit (STAREQ, RSTAREQ, and STPREQ) from 0 to 1.

22.8.3 UART2 Bit Rate Register (U2BRG)

Immediately after writing 00h to the U2BRG register, there may be a delay of up to 256 cycles of the count source when the following data transmission/reception starts (including the timing when the TI bit in the U2C1 register is set to 0 (data present in the U2TB register)) and when the start bit is detected during reception).

22.8.4 U2TB register

Write to this register using the MOV instruction.

When the multiprocessor communication function is used, write in 8-bit units. Set bits b0 to b7 after setting the MPTB bit.

When the multiprocessor communication function is not used, if the transfer data length is 9 bits, write in 16-bit units or write to the higher byte first and then the lower byte in 8-bit units.

23. Synchronous Serial Communication Unit (SSU)

Synchronous serial communication unit (SSU) supports clock synchronous serial data communication.

23.1 Overview

Table 23.1 shows a Synchronous Serial Communication Unit Specifications and Figure 23.1 shows a Block Diagram of Synchronous Serial Communication Unit.

Table 23.1 Synchronous Serial Communication Unit Specifications

Item	Specification
Transfer data format	<ul style="list-style-type: none"> Transfer data length: 8 to 16 bits Continuous transmission and reception of serial data are supported since both transmitter and receiver have buffer structures.
Operating modes	<ul style="list-style-type: none"> Clock synchronous communication mode 4-wire bus communication mode (including bidirectional communication)
Master/slave device	Selectable
I/O pins	SSCK (I/O): Clock I/O pin SSI (I/O): Data I/O pin SSO (I/O): Data I/O pin SCS (I/O): Chip-select I/O pin
Transfer clocks	<ul style="list-style-type: none"> When the MSS bit in the SSCRH register is set to 0 (operates as slave device), external clock is selected (input from SSCK pin). When the MSS bit in the SSCRH register is set to 1 (operates as master device), internal clock (selectable among f1/256, f1/128, f1/64, f1/32, f1/16, f1/8 and f1/4, output from SSCK pin) is selected. Clock polarity and phase of SSCK can be selected.
Receive error detection	<ul style="list-style-type: none"> Overrun error Overrun error occurs during reception and completes in error. While the RDRF bit in the SSSR register is set to 1 (data in the SSRDR register) and when next serial data receive is completed, the ORER bit is set to 1.
Multimaster error detection	<ul style="list-style-type: none"> Conflict error When the SSUMS bit in the SSMR2 register is set to 1 (4-wire bus communication mode) and the MSS bit in the SSCRH register is set to 1 (operates as master device) and when starting a serial communication, the CE bit in the SSSR register is set to 1 if "L" applies to the SCS pin input. When the SSUMS bit in the SSMR2 register is set to 1 (4-wire bus communication mode), the MSS bit in the SSCRH register is set to 0 (operates as slave device) and the SCS pin input changes state from "L" to "H", the CE bit in the SSSR register is set to 1.
Interrupt requests	5 interrupt requests (transmit-end, transmit-data-empty, receive-data-full, overrun error, and conflict error) ⁽¹⁾ .
Selectable functions	<ul style="list-style-type: none"> Data transfer direction <ul style="list-style-type: none"> Selects MSB-first or LSB-first SSCK clock polarity <ul style="list-style-type: none"> Selects "L" or "H" level when clock stops SSCK clock phase <ul style="list-style-type: none"> Selects edge of data change and data download

Note:

1. Synchronous serial communication unit has only one interrupt vector table.

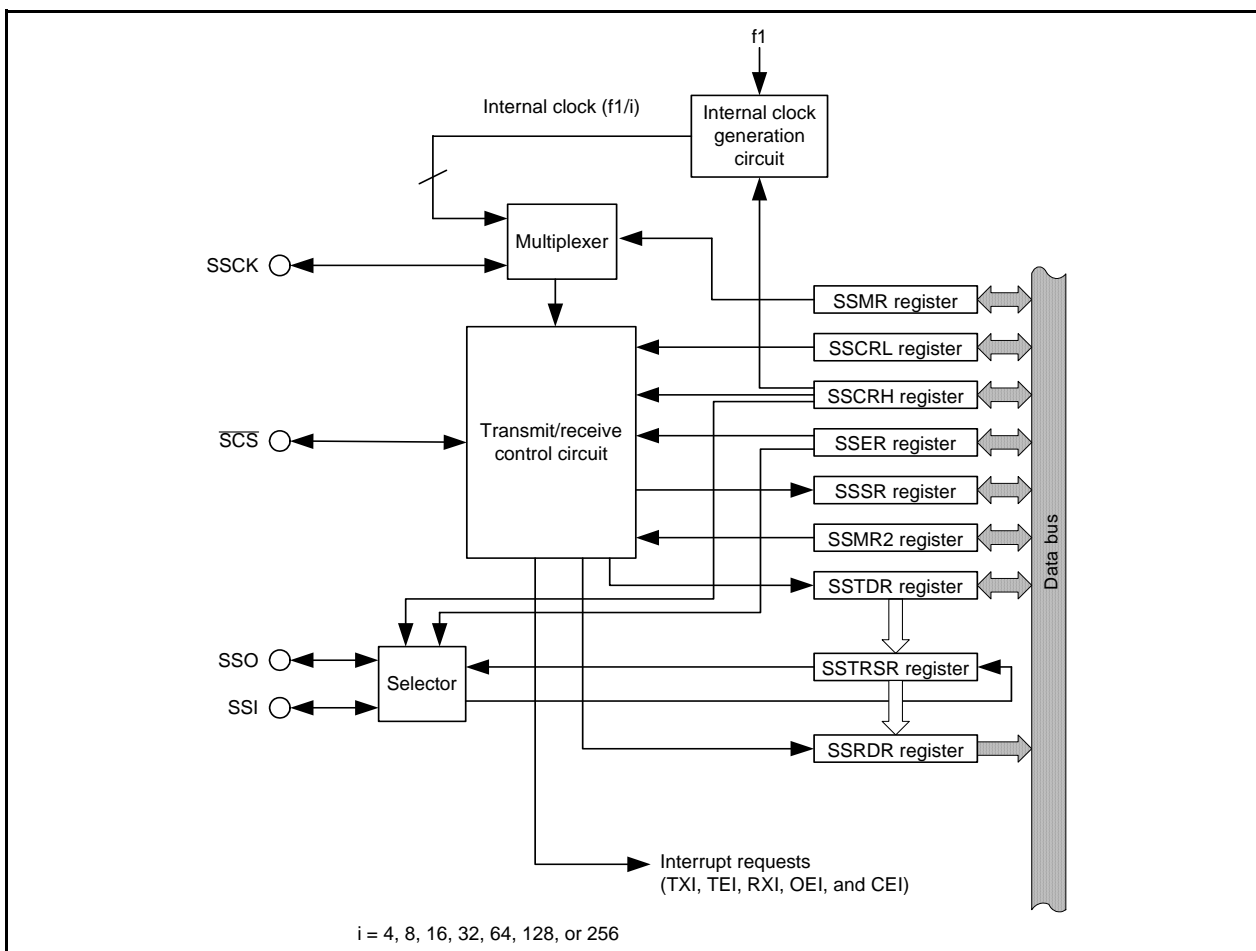

Figure 23.1 Block Diagram of Synchronous Serial Communication Unit

Table 23.2 Pin Configuration of Synchronous Serial Communication Unit

Pin Name	Assigned Pin	I/O	Function
SSI	P1_6 or P3_3	I/O	Data I/O pin
$\overline{\text{SCS}}$	P3_4	I/O	Chip-select signal I/O pin
SSCK	P3_5	I/O	Clock I/O pin
SSO	P3_7	I/O	Data I/O pin

23.2 Registers

23.2.1 Module Standby Control Register (MSTCR)

Address 0008h

Bit	b7	b6	b5	b4	b3	b2	b1	b0
Symbol	—	—	MSTTRC	MSTTRD	MSTIIC	—	—	—
After Reset	0	0	0	0	0	0	0	0

Bit	Symbol	Bit Name	Function	R/W
b0	—	Nothing is assigned. If necessary, set to 0. When read, the content is 0.		—
b1	—			
b2	—			
b3	MSTIIC	SSU standby bit	0: Active 1: Standby ⁽¹⁾	R/W
b4	MSTTRD	Timer RD standby bit	0: Active 1: Standby ^(2, 3)	R/W
b5	MSTTRC	Timer RC standby bit	0: Active 1: Standby ⁽⁴⁾	R/W
b6	—	Reserved bit	Set to 0.	R/W
b7	—	Nothing is assigned. If necessary, set to 0. When read, the content is 0.		—

Notes:

1. Stop the SSU and the I²C bus functions before setting to standby. When the MSTIIC bit is set to 1 (standby), any access to the SSU associated registers (addresses 0193h to 019Dh) is disabled.
2. Stop the timer RD function before setting to standby. When the MSTTRD bit is set to 1 (standby), any access to the timer RD associated registers (addresses 0135h to 015Fh) is disabled.
3. To set the MSTTRD bit to 1 (standby), set bits TCK2 to TCK0 in the TRDCR_i (i = 0 or 1) register to 000b (f1).
4. Stop the timer RC function before setting to standby. When the MSTTRC bit is set to 1 (standby), any access to the timer RC associated registers (addresses 0120h to 0133h) is disabled.

23.2.2 SSU Pin Select Register (SSUICSR)

Address 018Ch

Bit	b7	b6	b5	b4	b3	b2	b1	b0
Symbol	—	SCSSEL0	SSISEL1	SSISEL0	—	—	—	—
After Reset	0	0	0	0	0	0	0	0

Bit	Symbol	Bit Name	Function	R/W
b0	—	Reserved bits	Set to 0.	R/W
b1	—			R/W
b2	—	Nothing is assigned. If necessary, set to 0. When read, the content is 0.		—
b3	—			—
b4	SSISEL0	SSI pin select bit	b5 b4 0 0: SSI pin not used 0 1: P3_3 assigned 1 0: P1_6 assigned 1 1: Do not set.	R/W
b5	SSISEL1			R/W
b6	SCSSEL0	SCS pin select bit	0: SCS pin not used 1: P3_4 assigned	R/W
b7	—	Nothing is assigned. If necessary, set to 0. When read, the content is 0.		R/W

Bits SSISEL0 and SSISEL1 (SSI pin select bit)

Bits SSISEL0 and SSISEL1 select which pin is assigned to the SSU I/O. To use the I/O pin for SSU, set these bit.

Set the SSUICSR register setting the SSU associated registers. Also, do not change the setting value in this register during SSU operation.

SCSSEL0 Bit (SCS pin select bit)

The SCSSEL0 bit selects which pin is assigned to the SSU I/O. To use the I/O pin for SSU, set this bit.

Set the SSUICSR register setting the SSU associated registers. Also, do not change the setting value in this register during SSU operation.

23.2.3 SS Bit Counter Register (SSBR)

Address 0193h

Bit	b7	b6	b5	b4	b3	b2	b1	b0
Symbol	—	—	—	—	BS3	BS2	BS1	BS0
After Reset	1	1	1	1	1	0	0	0

Bit	Symbol	Bit Name	Function	R/W
b0	BS0	SSU data transfer length set bit ⁽¹⁾	b3 b2 b1 b0 0 0 0 0: 16 bits	R/W
b1	BS1		1 0 0 0: 8 bits	R/W
b2	BS2		1 0 0 1: 9 bits	R/W
b3	BS3		1 0 1 0: 10 bits 1 0 1 1: 11 bits 1 1 0 0: 12 bits 1 1 0 1: 13 bits 1 1 1 0: 14 bits 1 1 1 1: 15 bits	R/W
b4	—	Nothing is assigned. If necessary, set to 0. When read, the content is 1.		—
b5	—			
b6	—			
b7	—			

Note:

- Do not write to bits BS0 to BS3 during SSU operation.

To set the SSBR register, set the RE bit in the SSER register to 0 (reception disabled) and the TE bit to 0 (transmission disabled).

Bits BS0 to BS3 (SSU Data Transfer Length Set Bit)

As the SSU data transfer length, 8 to 16 bits can be used.

23.2.4 SS Transmit Data Register (SSTDR)

Address 0195h to 0194h

Bit	b7	b6	b5	b4	b3	b2	b1	b0
Symbol	—	—	—	—	—	—	—	—
After Reset	1	1	1	1	1	1	1	1

Bit	b15	b14	b13	b12	b11	b10	b9	b8
Symbol	—	—	—	—	—	—	—	—
After Reset	1	1	1	1	1	1	1	1

Bit	Symbol	Function	R/W
b15 to b0	—	Store the transmit data. ⁽¹⁾ The stored transmit data is transferred to the SSTRSR register and transmission is started when it is detected that the SSTRSR register is empty. When the next transmit data is written to the SSTDR register during the data transmission from the SSTRSR register, the data can be transmitted continuously. When the MLS bit in the SSMR register is set to 1 (transfer data with LSB-first), the data in which MSB and LSB are reversed is read, after writing to the SSTDR register.	R/W

Note:

- When the SSU data transfer length is set to 9 bits or more with the SSBR register, access the SSTDR register in 16-bit units.

23.2.5 SS Receive Data Register (SSRDR)

Address 0197h to 0196h

Bit	b7	b6	b5	b4	b3	b2	b1	b0
Symbol	—	—	—	—	—	—	—	—
After Reset	1	1	1	1	1	1	1	1

Bit	b15	b14	b13	b12	b11	b10	b9	b8
Symbol	—	—	—	—	—	—	—	—
After Reset	1	1	1	1	1	1	1	1

Bit	Symbol	Function	R/W
b15 to b0	—	Store the receive data. (1, 2) The receive data is transferred to the SSRDR register and the receive operation is completed when 1 byte of data has been received by the SSTRSR register. At this time, the next receive operation is possible. Continuous reception is possible using registers SSTRSR and SSRDR.	R

Notes:

1. The SSRDR register retains the data received before an overrun error occurs (ORER bit in the SSSR register set to 1 (overrun error)). When an overrun error occurs, the receive data may contain errors and therefore should be discarded.
2. When the SSU data transfer length is set to 9 bits or more with the SSBR register, access the SSRDR register in 16-bit units.

23.2.6 SS Control Register H (SSCRH)

Address 0198h

Bit	b7	b6	b5	b4	b3	b2	b1	b0
Symbol	—	RSSTP	MSS	—	—	CKS2	CKS1	CKS0
After Reset	0	0	0	0	0	0	0	0

Bit	Symbol	Bit Name	Function	R/W
b0	CKS0	Transfer clock select bit (1)	b2 b1 b0 0 0 0: f1/256 0 0 1: f1/128 0 1 0: f1/64 0 1 1: f1/32 1 0 0: f1/16 1 0 1: f1/8 1 1 0: f1/4 1 1 1: Do not set.	R/W
b1	CKS1			R/W
b2	CKS2			R/W
b3	—	Nothing is assigned. If necessary, set to 0. When read, the content is 0.		—
b4	—			—
b5	MSS	Master/slave device select bit (2)	0: Operates as slave device 1: Operates as master device	R/W
b6	RSSTP	Receive single stop bit (3)	0: Maintains receive operation after receiving 1 byte of data 1: Completes receive operation after receiving 1 byte of data	R/W
b7	—	Nothing is assigned. If necessary, set to 0. When read, the content is 0.		—

Notes:

1. The set clock is used when the MSS bit is set to 1 (operates as master device).
2. The SSCK pin functions as the transfer clock output pin when the MSS bit is set to 1 (operates as master device). The MSS bit is set to 0 (operates as slave device) when the CE bit in the SSSR register is set to 1 (conflict error occurs).
3. The RSSTP bit is disabled when the MSS bit is set to 0 (operates as slave device).

23.2.7 SS Control Register L (SSCRL)

Address 0199h

Bit	b7	b6	b5	b4	b3	b2	b1	b0
Symbol	—	—	SOL	SOLP	—	—	SRES	—
After Reset	0	1	1	1	1	1	0	1

Bit	Symbol	Bit Name	Function	R/W
b0	—	Nothing is assigned. If necessary, set to 0. When read, the content is 1.		—
b1	SRES	SSU control unit reset bit	Writing 1 to this bit resets the SSU control unit and the SSTRSR register. The value in the SSU internal register ⁽¹⁾ is retained.	R/W
b2	—	Nothing is assigned. If necessary, set to 0. When read, the content is 1.		—
b3	—			
b4	SOLP	SOL write protect bit ⁽²⁾	The output level can be changed by the SOL bit when this bit is set to 0. The SOLP bit remains unchanged even if 1 is written to it. When read, the content is 1.	R/W
b5	SOL	Serial data output value setting bit	When read 0: The serial data output is set to "L". 1: The serial data output is set to "H". When written ^(2, 3) 0: The data output is "L". 1: The data output is "H".	R/W
b6	—	Nothing is assigned. If necessary, set to 0. When read, the content is 1.		—
b7	—	Nothing is assigned. If necessary, set to 0. When read, the content is 0.		—

Notes:

- Registers SSBR, SSCRH, SSCRL, SSMR, SSER, SSSR, SSMR2, SSTDR, and SSRDR.
- For the data output after serial data transmission, the last bit value of the transmitted serial data is retained.
If the content of the SOL bit is rewritten before or after serial data transmission, the change is immediately reflected in the data output.
When writing to the SOL bit, set the SOLP bit to 0 and the SOL bit to 0 or 1 simultaneously by the MOV instruction.
- Do not write to the SOL bit during data transfer.

23.2.8 SS Mode Register (SSMR)

Address 019Ah

Bit	b7	b6	b5	b4	b3	b2	b1	b0
Symbol	MLS	CPOS	CPHS	—	BC3	BC2	BC1	BC0
After Reset	0	0	0	1	0	0	0	0

Bit	Symbol	Bit Name	Function	R/W
b0	BC0	Bits counter 3 to 0	b3 b2 b1 b0 0 0 0 0: 16 bits left	R
b1	BC1		0 0 0 1: 1 bit left	R
b2	BC2		0 0 1 0: 2 bits left	R
b3	BC3		0 0 1 1: 3 bits left	R
			0 1 0 0: 4 bits left	
		0 1 0 1: 5 bits left		
		0 1 1 0: 6 bits left		
		0 1 1 1: 7 bits left		
		1 0 0 0: 8 bits left		
		1 0 0 1: 9 bits left		
		1 0 1 0: 10 bits left		
		1 0 1 1: 11 bits left		
		1 1 0 0: 12 bits left		
		1 1 0 1: 13 bits left		
		1 1 1 0: 14 bits left		
		1 1 1 1: 15 bits left		
b4	—	Nothing is assigned. If necessary, set to 0. When read, the content is 1.		—
b5	CPHS	SSCK clock phase select bit ⁽¹⁾	0: Change data at odd edge (Download data at even edge) 1: Change data at even edge (Download data at odd edge)	R/W
b6	CPOS	SSCK clock polarity select bit ⁽¹⁾	0: "H" when clock stops 1: "L" when clock stops	R/W
b7	MLS	MSB first/LSB first select bit	0: Transfers data MSB first 1: Transfers data LSB first	R/W

Note:

1. Refer to **23.3.1.1 Association between Transfer Clock Polarity, Phase, and Data** for the settings of the CPHS and CPOS bits.
When the SSUMS bit in the SSMR2 register is set to 0 (clock synchronous communication mode), set the CPHS bit to 0 and the CPOS bit to 0.

23.2.9 SS Enable Register (SSER)

Address 019Bh

Bit	b7	b6	b5	b4	b3	b2	b1	b0
Symbol	TIE	TEIE	RIE	TE	RE	—	—	CEIE
After Reset	0	0	0	0	0	0	0	0

Bit	Symbol	Bit Name	Function	R/W
b0	CEIE	Conflict error interrupt enable bit	0: Disables conflict error interrupt request 1: Enables conflict error interrupt request	R/W
b1	—	Nothing is assigned. If necessary, set to 0. When read, the content is 0.		—
b2	—			
b3	RE	Receive enable bit	0: Disables receive 1: Enables receive	R/W
b4	TE	Transmit enable bit	0: Disables transmit 1: Enables transmit	R/W
b5	RIE	Receive interrupt enable bit	0: Disables receive data full and overrun error interrupt request 1: Enables receive data full and overrun error interrupt request	R/W
b6	TEIE	Transmit end interrupt enable bit	0: Disables transmit end interrupt request 1: Enables transmit end interrupt request	R/W
b7	TIE	Transmit interrupt enable bit	0: Disables transmit data empty interrupt request 1: Enables transmit data empty interrupt request	R/W

23.2.10 SS Status Register (SSSR)

Address 019Ch

Bit	b7	b6	b5	b4	b3	b2	b1	b0
Symbol	TDRE	TEND	RDRF	—	—	ORER	—	CE
After Reset	0	0	0	0	0	0	0	0

Bit	Symbol	Bit Name	Function	R/W
b0	CE	Conflict error flag ⁽¹⁾	0: No conflict errors generated 1: Conflict errors generated ⁽²⁾	R/W
b1	—	Nothing is assigned. If necessary, set to 0. When read, the content is 0.		—
b2	ORER	Overrun error flag ⁽¹⁾	0: No overrun errors generated 1: Overrun errors generated ⁽³⁾	R/W
b3	—	Nothing is assigned. If necessary, set to 0. When read, the content is 0.		—
b4	—			
b5	RDRF	Receive data register full flag ^(1, 4)	0: No data in SSRDR register 1: Data in SSRDR register	R/W
b6	TEND	Transmit end flag ^(1, 5)	0: The TDRE bit is set to 0 when transmitting the last bit of transmit data 1: The TDRE bit is set to 1 when transmitting the last bit of transmit data	R/W
b7	TDRE	Transmit data empty flag ^(1, 5, 6)	0: Data is not transferred from registers SSTDR to SSTRSR 1: Data is transferred from registers SSTDR to SSTRSR	R/W

Notes:

- Writing 1 to CE, ORER, RDRF, TEND, or TDRE bits is invalid. To set any of these bits to 0, first read 1 then write 0.
- When the serial communication is started while the SSUMS bit in the SSMR2 register is set to 1 (four-wire bus communication mode) and the MSS bit in the SSCRH register is set to 1 (operates as master device), the CE bit is set to 1 if "L" is applied to the SCS pin input. Refer to **23.5.4 SCS Pin Control and Arbitration** for more information.
When the SSUMS bit in the SSMR2 register is set to 1 (four-wire bus communication mode), the MSS bit in the SSCRH register is set to 0 (operates as slave device) and the SCS pin input changes the level from "L" to "H" during transfer, the CE bit is set to 1.
- Indicates when overrun errors occur and receive completes by error reception. If the next serial data receive operation is completed while the RDRF bit is set to 1 (data in the SSRDR register), the ORER bit is set to 1. After the ORER bit is set to 1 (overrun error), receive operation is disabled while the bit remains 1.
- The RDRF bit is set to 0 when reading out the data from the SSRDR register.
- Bits TEND and TDRE are set to 0 when writing data to the SSTDR register.
When reading these bits immediately after writing to the SSTDR register, insert three or more NOP instructions between the instructions used for writing and reading.
- The TDRE bit is set to 1 when the TE bit in the SSER register is set to 1 (transmit enabled).

If the SSSR register is accessed continuously, insert one or more NOP instructions between the instructions used for access.

23.2.11 SS Mode Register 2 (SSMR2)

Address 019Dh

Bit	b7	b6	b5	b4	b3	b2	b1	b0
Symbol	BIDE	SCKS	CSS1	CSS0	SCKOS	SOOS	CSOS	SSUMS
After Reset	0	0	0	0	0	0	0	0

Bit	Symbol	Bit Name	Function	R/W
b0	SSUMS	SSU mode select bit ⁽¹⁾	0: Clock synchronous communication mode 1: Four-wire bus communication mode	R/W
b1	CSOS	\overline{SCS} pin open drain output select bit	0: CMOS output 1: N-channel open-drain output	R/W
b2	SOOS	Serial data pin open output drain select bit ⁽¹⁾	0: CMOS output ⁽⁵⁾ 1: N-channel open-drain output	R/W
b3	SCKOS	SSCK pin open drain output select bit	0: CMOS output 1: N-channel open-drain output	R/W
b4	CSS0	\overline{SCS} pin select bit ⁽²⁾	b5 b4 0 0: Functions as port 0 1: Functions as \overline{SCS} input pin 1 0: Functions as \overline{SCS} output pin ⁽³⁾ 1 1: Functions as \overline{SCS} output pin ⁽³⁾	R/W
b5	CSS1			R/W
b6	SCKS	SSCK pin select bit	0: Functions as port 1: Functions as serial clock pin	R/W
b7	BIDE	Bidirectional mode enable bit ^(1, 4)	0: Standard mode (communication using 2 pins of data input and data output) 1: Bidirectional mode (communication using 1 pin of data input and data output)	R/W

Notes:

1. Refer to **23.3.2.1 Association between Data I/O Pins and SS Shift Register** for information on combinations of data I/O pins.
2. The \overline{SCS} pin functions as a port, regardless of the values of bits CSS0 and CSS1 when the SSUMS bit is set to 0 (clock synchronous communication mode).
3. This bit functions as the \overline{SCS} input pin before starting transfer.
4. The BIDE bit is disabled when the SSUMS bit is set to 0 (clock synchronous communication mode).
5. When the SOOS bit is set to 0 (CMOS output), set the port direction register bits corresponding to pins SSI and SSO to 0 (input mode).

23.3 Common Items for Multiple Modes

23.3.1 Transfer Clock

The transfer clock can be selected from among seven internal clocks (f1/256, f1/128, f1/64, f1/32, f1/16, f1/8, and f1/4) and an external clock.

When using synchronous serial communication unit, set the SCKS bit in the SSMR2 register to 1 and select the SSCK pin as the serial clock pin.

When the MSS bit in the SSCRH register is set to 1 (operates as master device), an internal clock can be selected and the SSCK pin functions as output. When transfer is started, the SSCK pin outputs clocks of the transfer rate selected by bits CKS0 to CKS2 in the SSCRH register.

When the MSS bit in the SSCRH register is set to 0 (operates as slave device), an external clock can be selected and the SSCK pin functions as input.

23.3.1.1 Association between Transfer Clock Polarity, Phase, and Data

The association between the transfer clock polarity, phase and data changes according to the combination of the SSUMS bit in the SSMR2 register and bits CPHS and CPOS in the SSMR register.

Figure 23.2 shows the Association between Transfer Clock Polarity, Phase, and Transfer Data.

Also, the MSB-first transfer or LSB-first transfer can be selected by setting the MLS bit in the SSMR register. When the MLS bit is set to 1, transfer is started from the LSB and proceeds to the MSB. When the MLS bit is set to 0, transfer is started from the MSB and proceeds to the LSB.

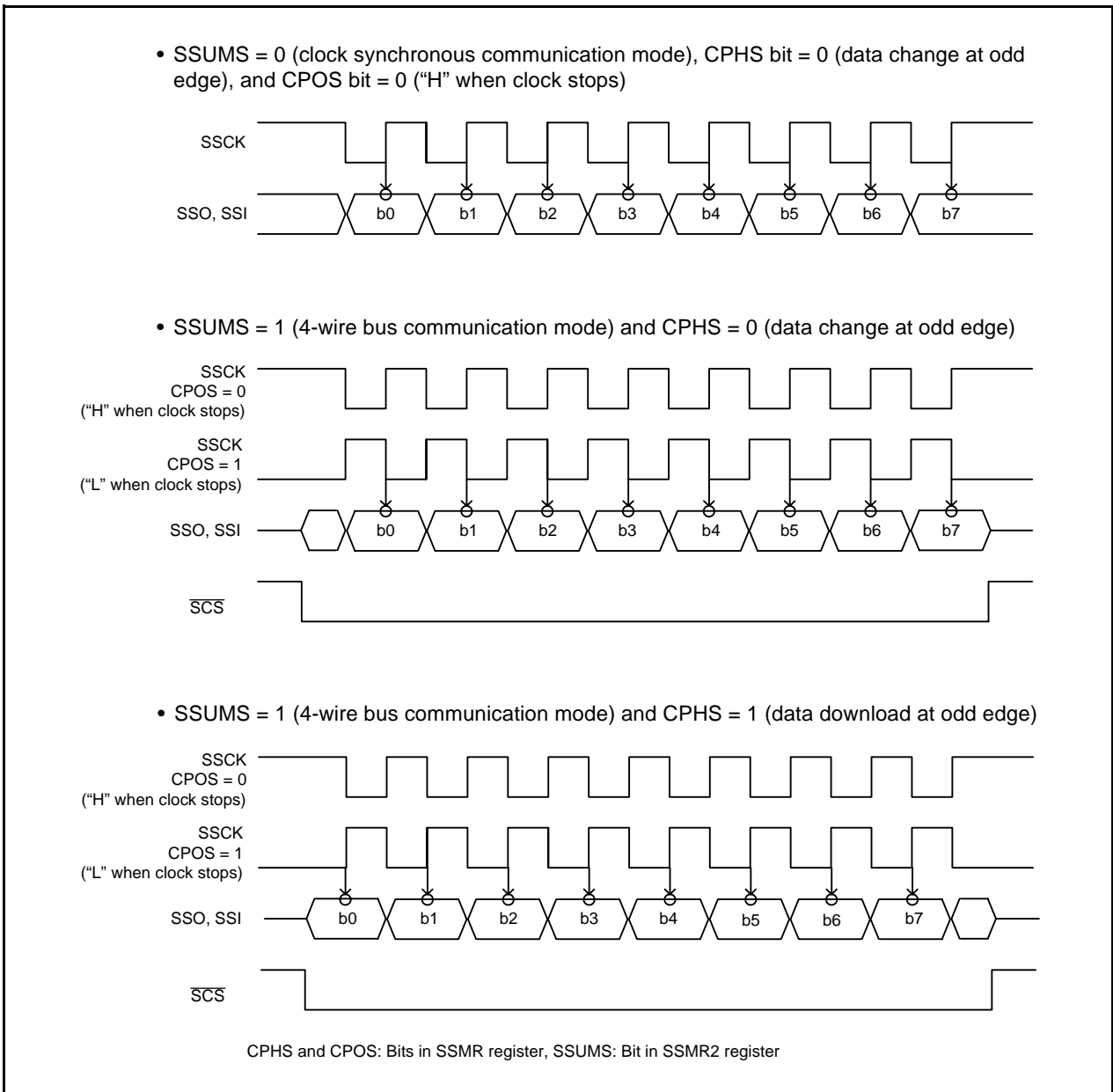

Figure 23.2 Association between Transfer Clock Polarity, Phase, and Transfer Data

23.3.2 SS Shift Register (SSTRSR)

The SSTRSR register is a shift register for transmitting and receiving serial data.

When transmit data is transferred from the SSTDR register to the SSTRSR register and the MLS bit in the SSMR register is set to 0 (MSB-first), the bit 0 in the SSTDR register is transferred to bit 0 in the SSTRSR register. When the MLS bit is set to 1 (LSB-first), bit 7 in the SSTDR register is transferred to bit 0 in the SSTRSR register.

23.3.2.1 Association between Data I/O Pins and SS Shift Register

The connection between the data I/O pins and SSTRSR register (SS shift register) changes according to a combination of the MSS bit in the SSCRH register and the SSUMS bit in the SSMR2 register. The connection also changes according to the BIDE bit in the SSMR2 register.

Figure 23.3 shows the Association between Data I/O Pins and SSTRSR Register.

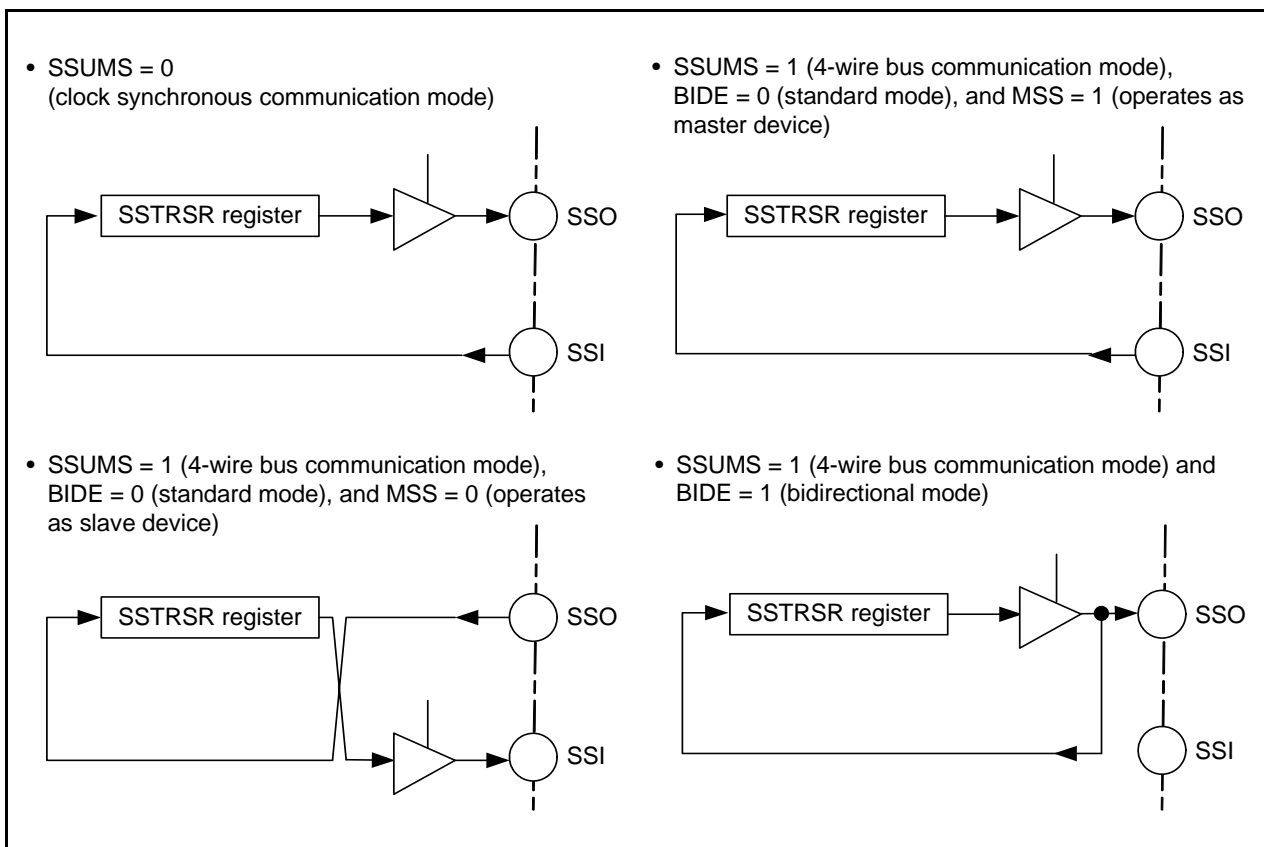

Figure 23.3 Association between Data I/O Pins and SSTRSR Register

23.3.3 Interrupt Requests

Synchronous serial communication unit has five interrupt requests: transmit data empty, transmit end, receive data full, overrun error, and conflict error. Since these interrupt requests are assigned to the synchronous serial communication unit interrupt vector table, determining interrupt sources by flags is required.

Table 23.3 shows the Synchronous Serial Communication Unit Interrupt Requests.

Table 23.3 Synchronous Serial Communication Unit Interrupt Requests

Interrupt Request	Abbreviation	Generation Condition
Transmit data empty	TXI	TIE = 1, TDRE = 1
Transmit end	TEI	TEIE = 1, TEND = 1
Receive data full	RXI	RIE = 1, RDRF = 1
Overrun error	OEI	RIE = 1, ORER = 1
Conflict error	CEI	CEIE = 1, CE = 1

CEIE, RIE, TEIE and TIE: Bits in SSER register

ORER, RDRF, TEND and TDRE: Bits in SSSR register

If the generation conditions in Table 23.3 are met, a synchronous serial communication unit interrupt request is generated. Set each interrupt source to 0 by a synchronous serial communication unit interrupt routine.

However, the TDRE and TEND bits are automatically set to 0 by writing transmit data to the SSTDR register and the RDRF bit is automatically set to 0 by reading the SSRDR register. In particular, the TDRE bit is set to 1 (data transmitted from registers SSTDR to SSTRSR) at the same time transmit data is written to the SSTDR register. Setting the TDRE bit to 0 (data not transmitted from registers SSTDR to SSTRSR) can cause an additional byte of data to be transmitted.

23.3.4 Communication Modes and Pin Functions

Synchronous serial communication unit switches the functions of the I/O pins in each communication mode according to the setting of the MSS bit in the SSCRH register and bits RE and TE in the SSER register.

Table 23.4 shows the Association between Communication Modes and I/O Pins.

Table 23.4 Association between Communication Modes and I/O Pins

Communication Mode	Bit Setting					Pin State		
	SSUMS	BIDE	MSS	TE	RE	SSI	SSO	SSCK
Clock synchronous communication mode	0	Disabled	0	0	1	Input	– (1)	Input
				1	0	– (1)	Output	Input
				1	1	Input	Output	Input
			1	0	1	Input	– (1)	Output
				1	0	– (1)	Output	Output
				1	1	Input	Output	Output
4-wire bus communication mode	1	0	0	0	1	– (1)	Input	Input
				1	0	Output	– (1)	Input
				1	1	Output	Input	Input
			1	0	1	Input	– (1)	Output
				1	0	– (1)	Output	Output
				1	1	Input	Output	Output
4-wire bus (bidirectional) communication mode (2)	1	1	0	0	1	– (1)	Input	Input
				1	0	– (1)	Output	Input
			1	0	1	– (1)	Input	Output
				1	0	– (1)	Output	Output

Notes:

1. This pin can be used as a programmable I/O port.
2. Do not set both bits TE and RE to 1 in 4-wire bus (bidirectional) communication mode.

SSUMS and BIDE: Bits in SSMR2 register

MSS: Bit in SSCRH register

TE and RE: Bits in SSER register

23.4 Clock Synchronous Communication Mode

23.4.1 Initialization in Clock Synchronous Communication Mode

Figure 23.4 shows Initialization in Clock Synchronous Communication Mode. To initialize, set the TE bit in the SSER register to 0 (transmit disabled) and the RE bit to 0 (receive disabled) before data transmission or reception.

Set the TE bit to 0 and the RE bit to 0 before changing the communication mode or format.

Setting the RE bit to 0 does not change the contents of flags RDRF and ORER or the contents of the SSRDR register.

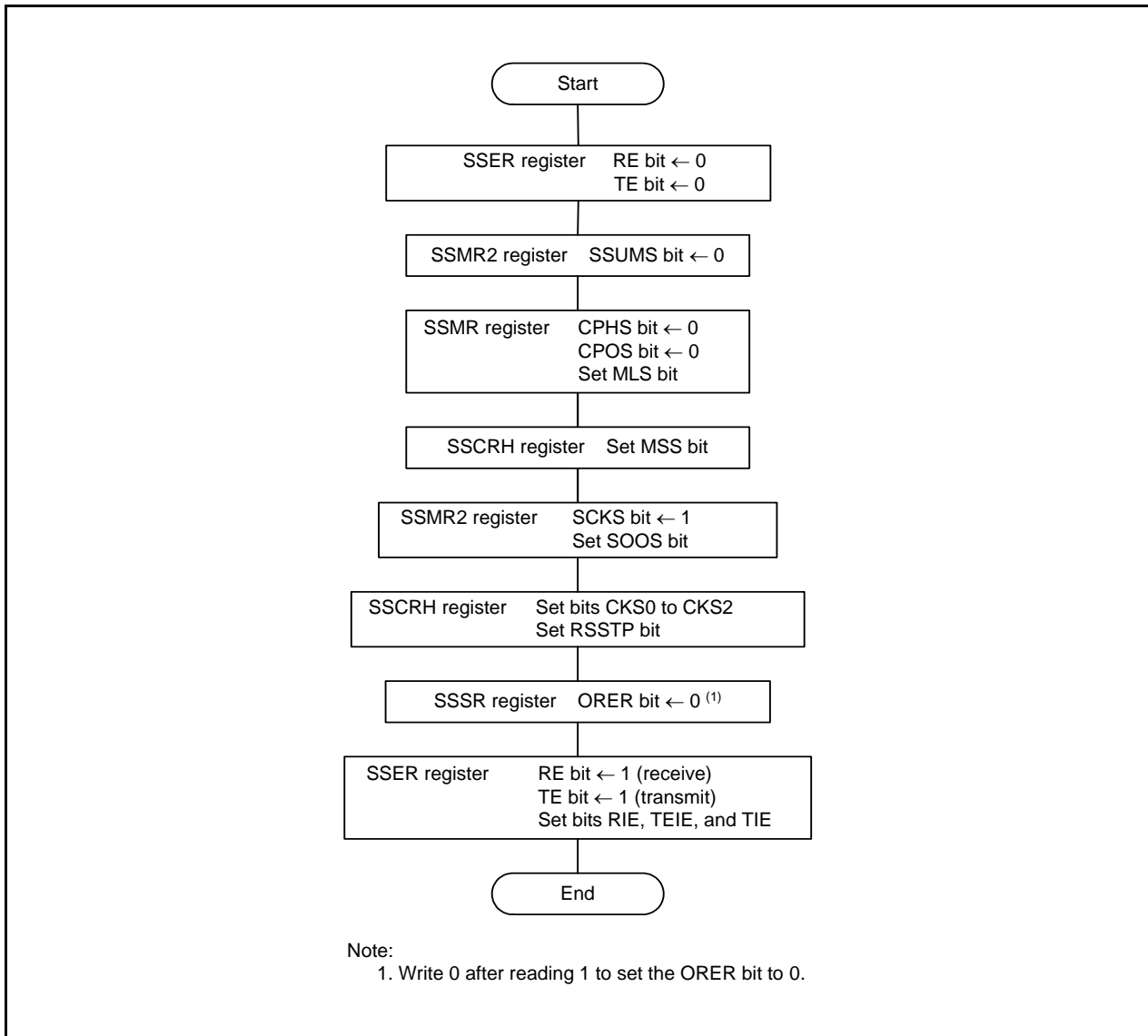

Figure 23.4 Initialization in Clock Synchronous Communication Mode

23.4.2 Data Transmission

Figure 23.5 shows an Example of Synchronous Serial Communication Unit Operation for Data Transmission (Clock Synchronous Communication Mode, 8-Bit SSU Data Transfer Length). During data transmission, the synchronous serial communication unit operates as described below (The data transfer length can be set from 8 to 16 bits using the SSBR register).

When synchronous serial communication unit is set as a master device, it outputs a synchronous clock and data. When synchronous serial communication unit is set as a slave device, it outputs data synchronized with the input clock.

When the TE bit is set to 1 (transmit enabled) before writing the transmit data to the SSTDR register, the TDRE bit is automatically set to 0 (data not transferred from registers SSTDR to SSTRSR) and the data is transferred from registers SSTDR to SSTRSR.

After the TDRE bit is set to 1 (data transferred from registers SSTDR to SSTRSR), transmission starts. When the TIE bit in the SSER register is set to 1, the TXI interrupt request is generated. When one frame of data is transferred while the TDRE bit is set to 0, data is transferred from registers SSTDR to SSTRSR and transmission of the next frame is started. If the 8th bit is transmitted while the TDRE bit is set to 1, the TEND bit in the SSSR register is set to 1 (the TDRE bit is set to 1 when the last bit of the transmit data is transmitted) and the state is retained. The TEI interrupt request is generated when the TEIE bit in the SSER register is set to 1 (transmit-end interrupt request enabled). The SSCK pin is fixed "H" after transmit-end.

Transmission cannot be performed while the ORER bit in the SSSR register is set to 1 (overrun error). Confirm that the ORER bit is set to 0 before transmission.

Figure 23.6 shows a Sample Flowchart of Data Transmission (Clock Synchronous Communication Mode).

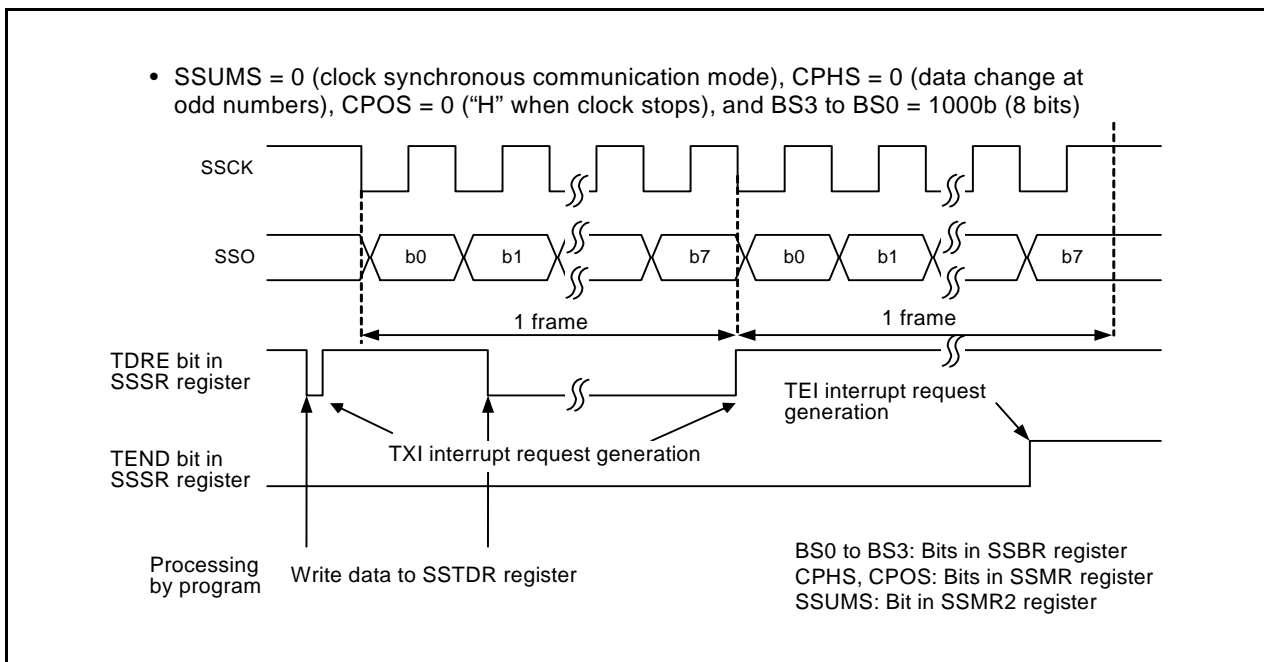

Figure 23.5 Example of Synchronous Serial Communication Unit Operation for Data Transmission (Clock Synchronous Communication Mode, 8-Bit SSU Data Transfer Length)

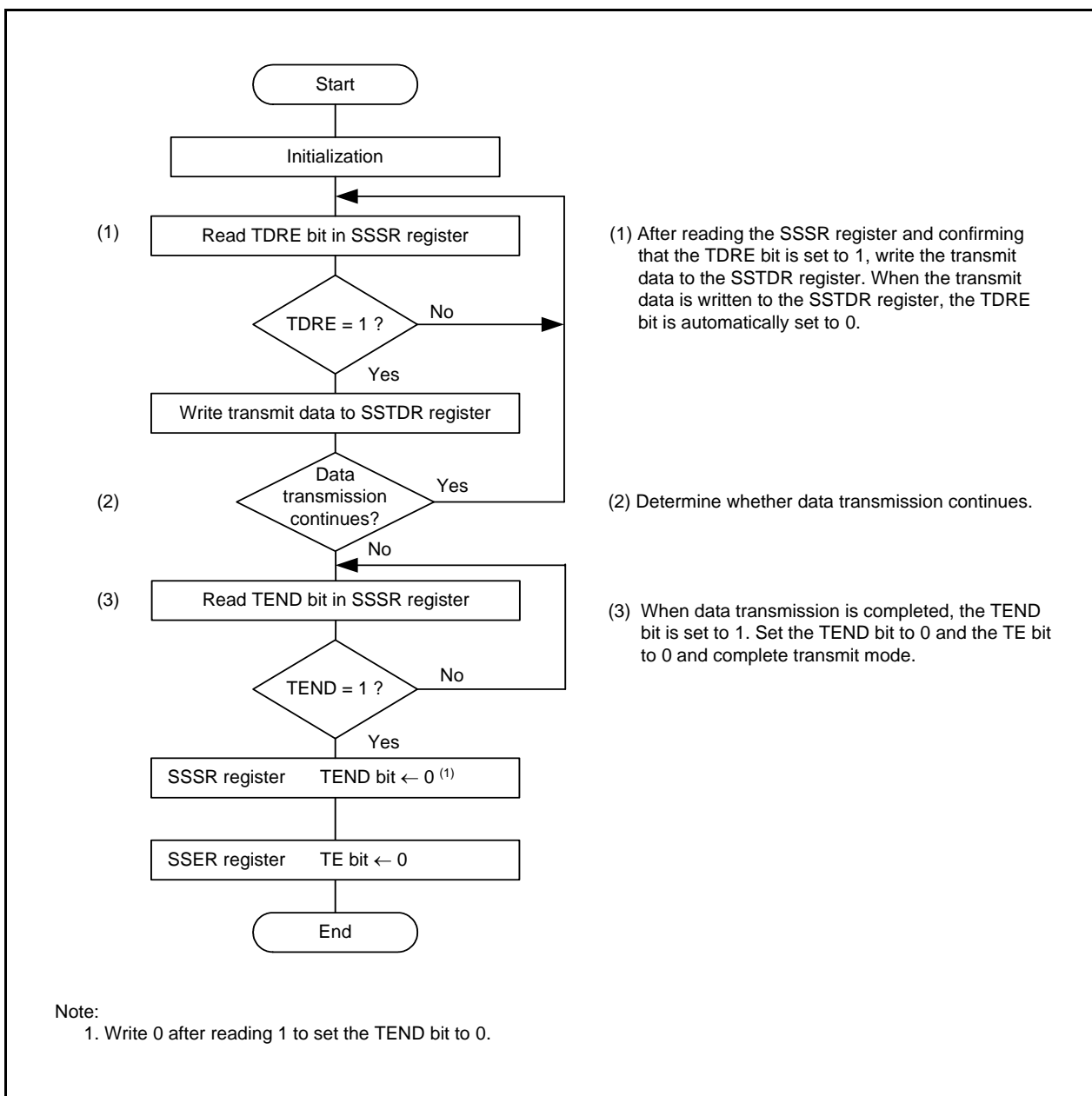

Figure 23.6 Sample Flowchart of Data Transmission (Clock Synchronous Communication Mode)

23.4.3 Data Reception

Figure 23.7 shows an Example of Synchronous Serial Communication Unit Operation for Data Reception (Clock Synchronous Communication Mode, 8-Bit SSU Data Transfer Length). During data reception, synchronous serial communication unit operates as described below (The data transfer length can be set from 8 to 16 bits using the SSBR register).

When the synchronous serial communication unit is set as the master device, it outputs a synchronous clock and inputs data. When synchronous serial communication unit is set as a slave device, it inputs data synchronized with the input clock.

When synchronous serial communication unit is set as a master device, it outputs a receive clock and starts receiving by performing dummy read of the SSRDR register.

After 8 bits of data are received, the RDRF bit in the SSSR register is set to 1 (data in the SSRDR register) and receive data is stored in the SSRDR register. When the RIE bit in the SSER register is set to 1 (RXI and OEI interrupt requests enabled), the RXI interrupt request is generated. If the SSSR register is read, the RDRF bit is automatically set to 0 (no data in the SSRDR register).

Read the receive data after setting the RSSTP bit in the SSCRH register to 1 (after receiving 1 byte of data, the receive operation is completed). Synchronous serial communication unit outputs a clock for receiving 8 bits of data and stops. After that, set the RE bit in the SSER register to 0 (receive disabled) and the RSSTP bit to 0 (receive operation is continued after receiving the 1 byte of data) and read the receive data. If the SSRDR register is read while the RE bit is set to 1 (receive enabled), a receive clock is output again.

When the 8th clock rises while the RDRF bit is set to 1, the ORER bit in the SSSR register is set to 1 (overrun error: OEI) and the operation is stopped. When the ORER bit is set to 1, receive cannot be performed. Confirm that the ORER bit is set to 0 before restarting receive.

Figure 23.8 shows a Sample Flowchart of Data Reception (MSS = 1) (Clock Synchronous Communication Mode).

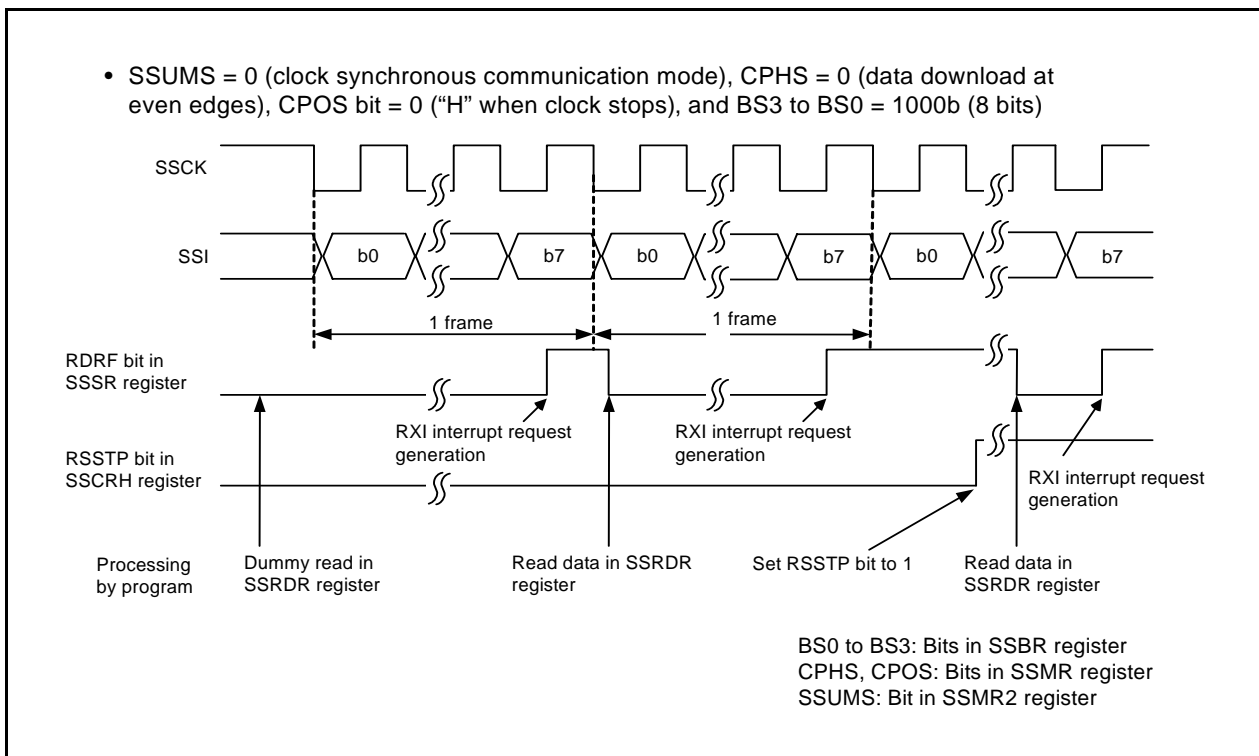

Figure 23.7 Example of Synchronous Serial Communication Unit Operation for Data Reception (Clock Synchronous Communication Mode, 8-Bit SSU Data Transfer Length)

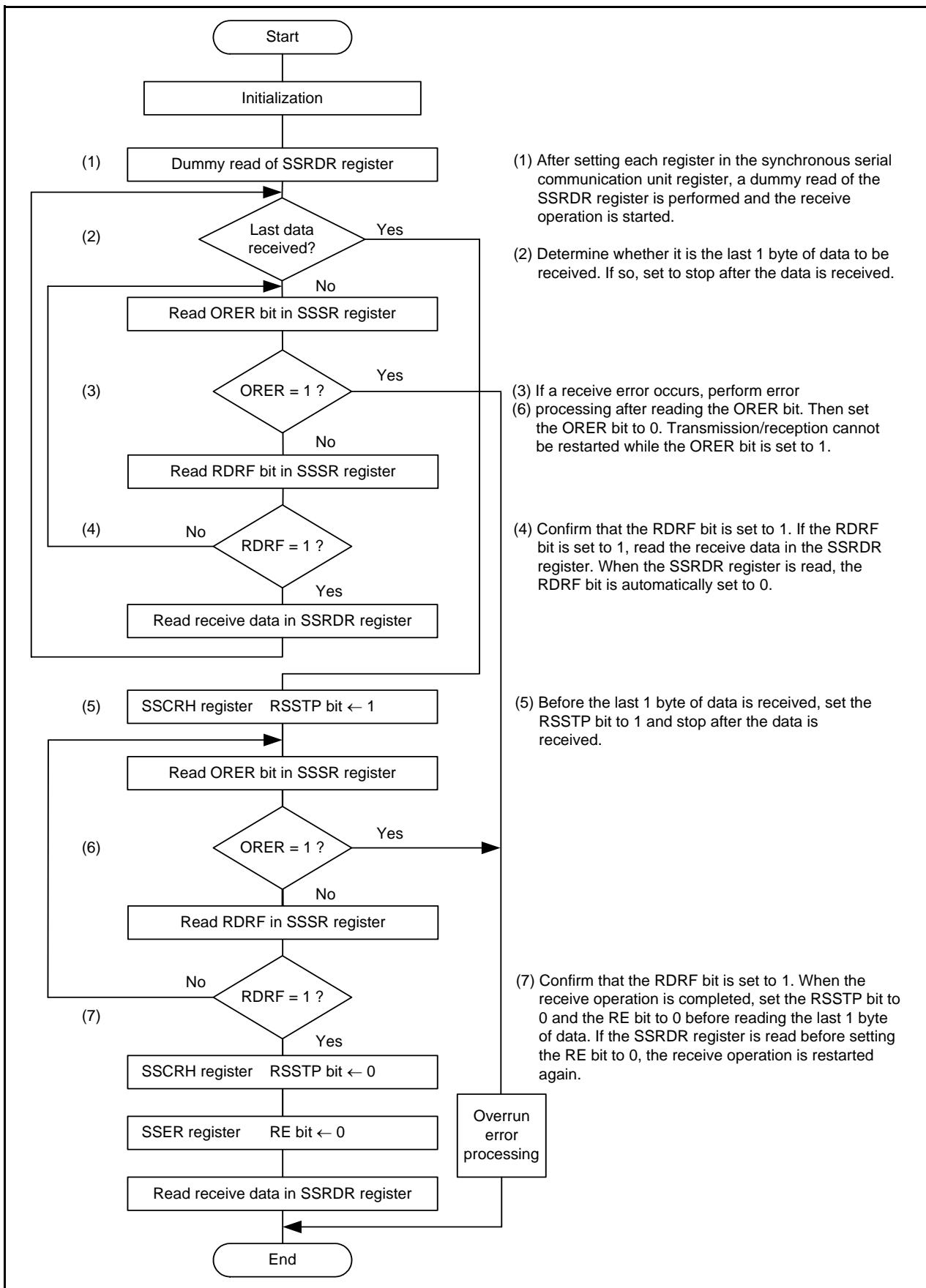

Figure 23.8 Sample Flowchart of Data Reception (MSS = 1) (Clock Synchronous Communication Mode)

23.4.3.1 Data Transmission/Reception

Data transmission/reception is an operation combining data transmission and reception which were described earlier. Transmission/reception is started by writing data to the SSTDR register.

When the last transfer clock (The data transfer length can be set from 8 to 16 bits using the SSBR register) rises or the ORER bit is set to 1 (overrun error) while the TDRE bit is set to 1 (data is transferred from registers SSTDR to SSTRSR), the transmit/receive operation is stopped.

When switching from transmit mode (TE = 1) or receive mode (RE = 1) to transmit/receive mode (TE = RE = 1), set the TE bit to 0 and RE bit to 0 before switching. After confirming that the TEND bit is set to 0 (the TDRE bit is set to 0 when the last bit of the transmit data is transmitted), the RDRF bit is set to 0 (no data in the SSRDR register), and the ORER bit is set to 0 (no overrun error), set bits TE and RE to 1.

Figure 23.9 shows a Sample Flowchart of Data Transmission/Reception (Clock Synchronous Communication Mode).

When exiting transmit/receive mode after this mode is used (TE = RE = 1), a clock may be output if transmit/receive mode is exited after reading the SSRDR register. To avoid any clock outputs, perform either of the following:

- First set the RE bit to 0, and then set the TE bit to 0.
- Set bits TE and RE to 0 at the same time.

When subsequently switching to receive mode (TE = 0 and RE = 1), first set the SRES bit to 1, and set this bit to 0 to reset the SSU control unit and the SSTRSR register. Then, set the RE bit to 1.

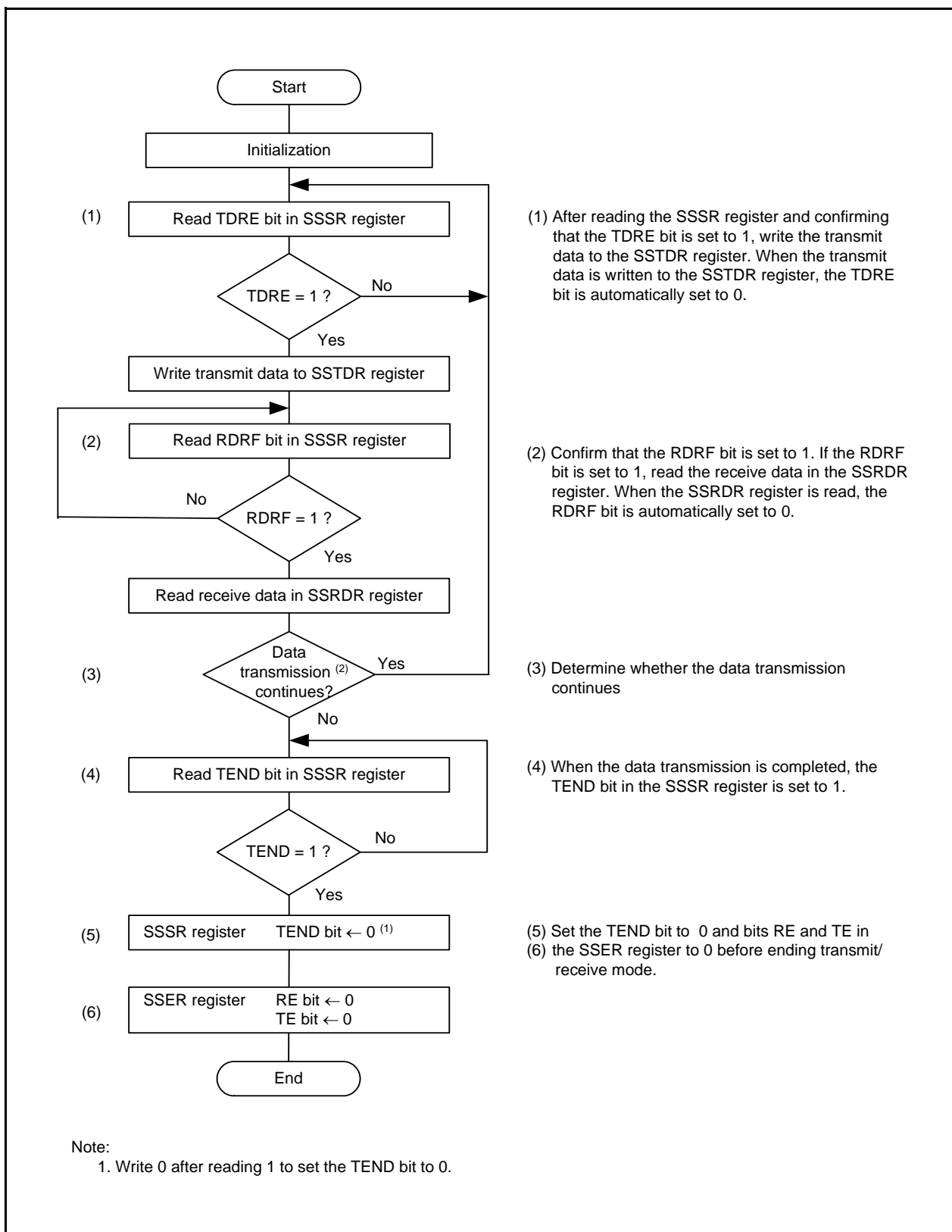

Figure 23.9 Sample Flowchart of Data Transmission/Reception (Clock Synchronous Communication Mode)

23.5 Operation in 4-Wire Bus Communication Mode

In 4-wire bus communication mode, a 4-wire bus consisting of a clock line, a data input line, a data output line, and a chip select line is used for communication. This mode includes bidirectional mode in which the data input line and data output line function as a single pin.

The data input line and output line change according to the settings of the MSS bit in the SSCRH register and the BIDE bit in the SSMR2 register. For details, refer to **23.3.2.1 Association between Data I/O Pins and SS Shift Register**. In this mode, clock polarity, phase, and data settings are performed by bits CPOS and CPHS in the SSMR register. For details, refer to **23.3.1.1 Association between Transfer Clock Polarity, Phase, and Data**.

When this MCU is set as the master device, the chip select line controls output. When synchronous serial communication unit is set as a slave device, the chip select line controls input. When it is set as the master device, the chip select line controls output of the $\overline{\text{SCS}}$ pin or controls output of a general port according to the setting of the CSS1 bit in the SSMR2 register. When the MCU is set as a slave device, the chip select line sets the $\overline{\text{SCS}}$ pin as an input pin by setting bits CSS1 and CSS0 in the SSMR2 register to 01b.

In 4-wire bus communication mode, the MLS bit in the SSMR register is set to 0 and communication is performed MSB-first.

23.5.1 Initialization in 4-Wire Bus Communication Mode

Figure 23.10 shows Initialization in 4-Wire Bus Communication Mode. Before the data transit/receive operation, set the TE bit in the SSER register to 0 (transmit disabled), the RE bit in the SSER register to 0 (receive disabled), and initialize the synchronous serial communication unit.

To change the communication mode or format, set the TE bit to 0 and the RE bit to 0 before making the change. Setting the RE bit to 0 does not change the settings of flags RDRF and ORER or the contents of the SSRDR register.

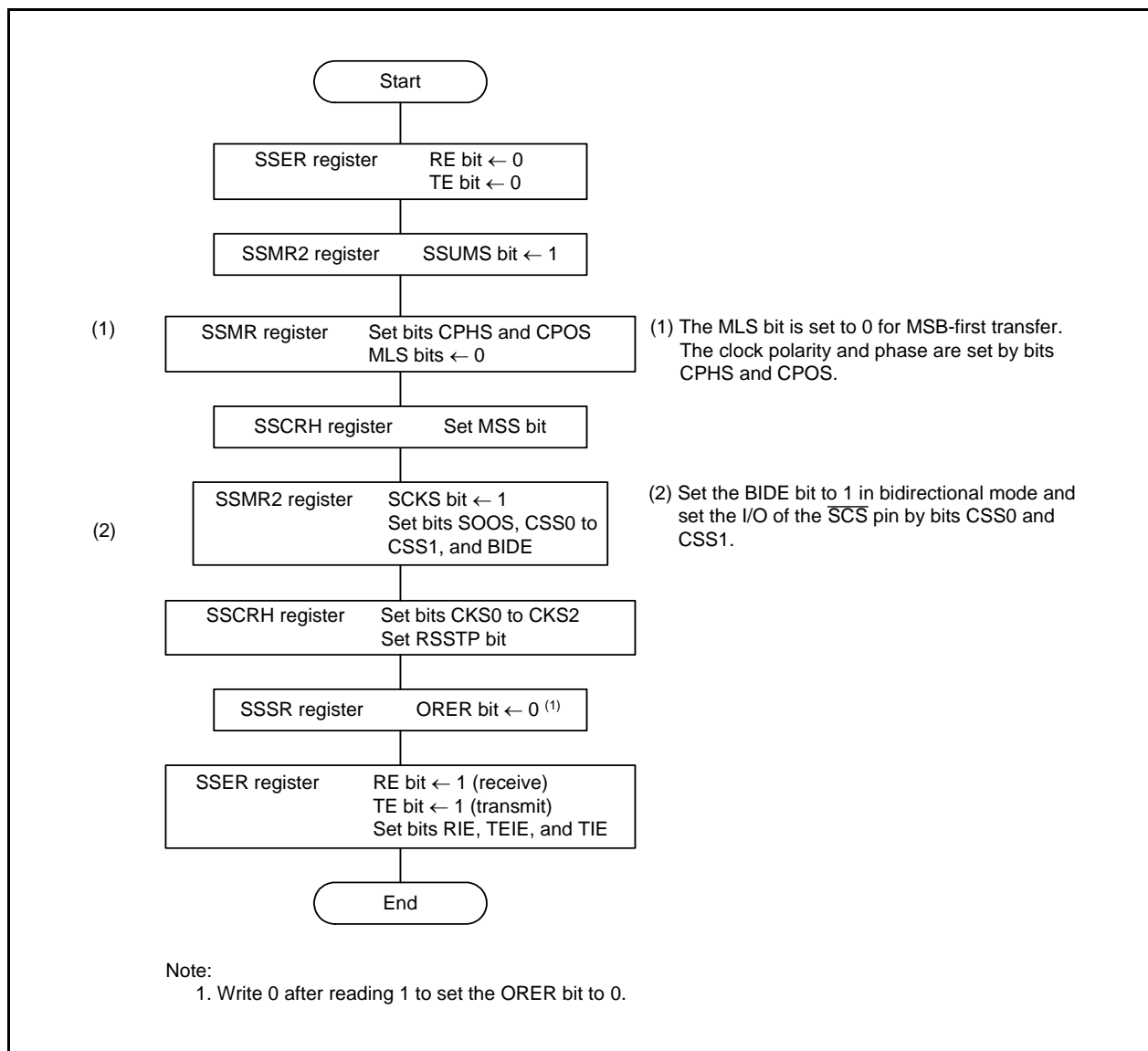

Figure 23.10 Initialization in 4-Wire Bus Communication Mode

23.5.2 Data Transmission

Figure 23.11 shows an Example of Synchronous Serial Communication Unit Operation during Data Transmission (4-Wire Bus Communication Mode, 8-Bit SSU Data Transfer Length). During the data transmit operation, synchronous serial communication unit operates as described below (The data transfer length can be set from 8 to 16 bits using the SSBR register).

When the MCU is set as the master device, it outputs a synchronous clock and data. When the MCU is set as a slave device, it outputs data in synchronization with the input clock while the $\overline{\text{SCS}}$ pin is "L".

When the transmit data is written to the SSTDR register after setting the TE bit to 1 (transmit enabled), the TDRE bit is automatically set to 0 (data has not been transferred from registers SSTDR to SSTRSR) and the data is transferred from registers SSTDR to SSTRSR. After the TDRE bit is set to 1 (data is transferred from registers SSTDR to SSTRSR), transmission starts. When the TIE bit in the SSER register is set to 1, a TXI interrupt request is generated.

After 1 frame of data is transferred while the TDRE bit is set to 0, the data is transferred from registers SSTDR to SSTRSR and transmission of the next frame is started. If the 8th bit is transmitted while TDRE is set to 1, TEND in the SSSR register is set to 1 (when the last bit of the transmit data is transmitted, the TDRE bit is set to 1) and the state is retained. If the TEIE bit in the SSER register is set to 1 (transmit-end interrupt requests enabled), a TEI interrupt request is generated. The SSCK pin remains "H" after transmit-end and the $\overline{\text{SCS}}$ pin is held "H". When transmitting continuously while the $\overline{\text{SCS}}$ pin is held "L", write the next transmit data to the SSTDR register before transmitting the 8th bit.

Transmission cannot be performed while the ORER bit in the SSSR register is set to 1 (overrun error). Confirm that the ORER bit is set to 0 before transmission.

In contrast to the clock synchronous communication mode, the SSO pin is placed in high-impedance state while the $\overline{\text{SCS}}$ pin is placed in high-impedance state when operating as a master device and the SSI pin is placed in high-impedance state while the $\overline{\text{SCS}}$ pin is placed in "H" input state when operating as a slave device.

The sample flowchart is the same as that for the clock synchronous communication mode (refer to **Figure 23.6 Sample Flowchart of Data Transmission (Clock Synchronous Communication Mode)**).

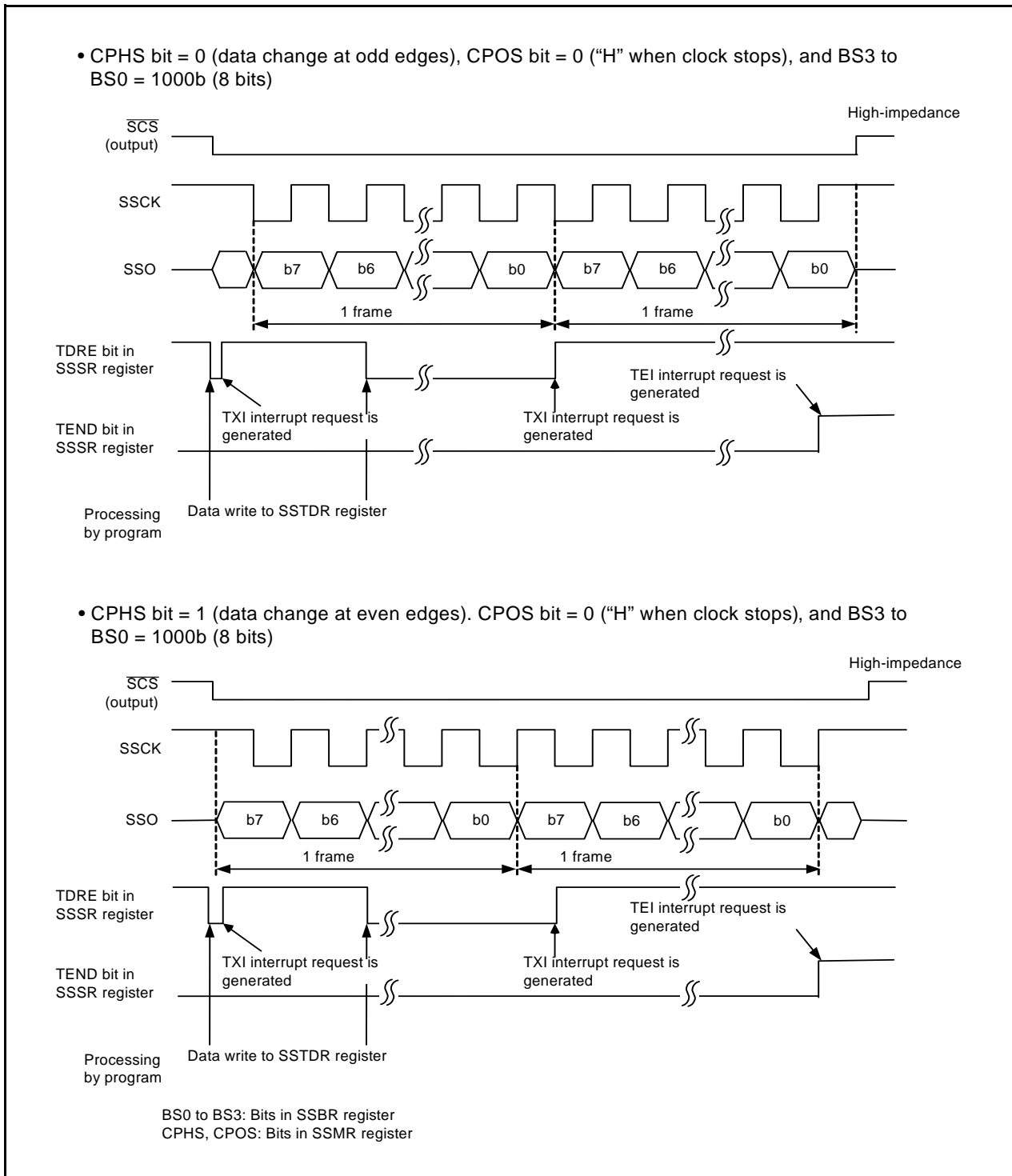

Figure 23.11 Example of Synchronous Serial Communication Unit Operation during Data Transmission (4-Wire Bus Communication Mode, 8-Bit SSU Data Transfer Length)

23.5.3 Data Reception

Figure 23.12 shows an Example of Synchronous Serial Communication Unit Operation during Data Reception (4-Wire Bus Communication Mode, 8-Bit SSU Data Transfer Length). During data reception, synchronous serial communication unit operates as described below (The data transfer length can be set from 8 to 16 bits using the SSBR register).

When the MCU is set as the master device, it outputs a synchronous clock and inputs data. When the MCU is set as a slave device, it outputs data synchronized with the input clock while the \overline{SCS} pin receives "L" input. When the MCU is set as the master device, it outputs a receive clock and starts receiving by performing a dummy read of the SSRDR register.

After 8 bits of data are received, the RDRF bit in the SSSR register is set to 1 (data in the SSRDR register) and receive data is stored in the SSRDR register. When the RIE bit in the SSER register is set to 1 (RXI and OEI interrupt requests enabled), an RXI interrupt request is generated. When the SSRDR register is read, the RDRF bit is automatically set to 0 (no data in the SSRDR register).

Read the receive data after setting the RSSTP bit in the SSCRH register to 1 (after receiving 1-byte data, the receive operation is completed). Synchronous serial communication unit outputs a clock for receiving 8 bits of data and stops. After that, set the RE bit in the SSER register to 0 (receive disabled) and the RSSTP bit to 0 (receive operation is continued after receiving 1-byte data) and read the receive data. When the SSRDR register is read while the RE bit is set to 1 (receive enabled), a receive clock is output again.

When the 8th clock rises while the RDRF bit is set to 1, the ORER bit in the SSSR register is set to 1 (overrun error: OEI) and the operation is stopped. When the ORER bit is set to 1, reception cannot be performed. Confirm that the ORER bit is set to 0 before restarting reception.

The timing with which bits RDRF and ORER are set to 1 varies depending on the setting of the CPHS bit in the SSMR register. Figure 23.12 shows when bits RDRF and ORER are set to 1.

When the CPHS bit is set to 1 (data download at the odd edges), bits RDRF and ORER are set to 1 at some point during the frame.

The sample flowchart is the same as that for the clock synchronous communication mode (refer to **Figure 23.8 Sample Flowchart of Data Reception (MSS = 1) (Clock Synchronous Communication Mode)**).

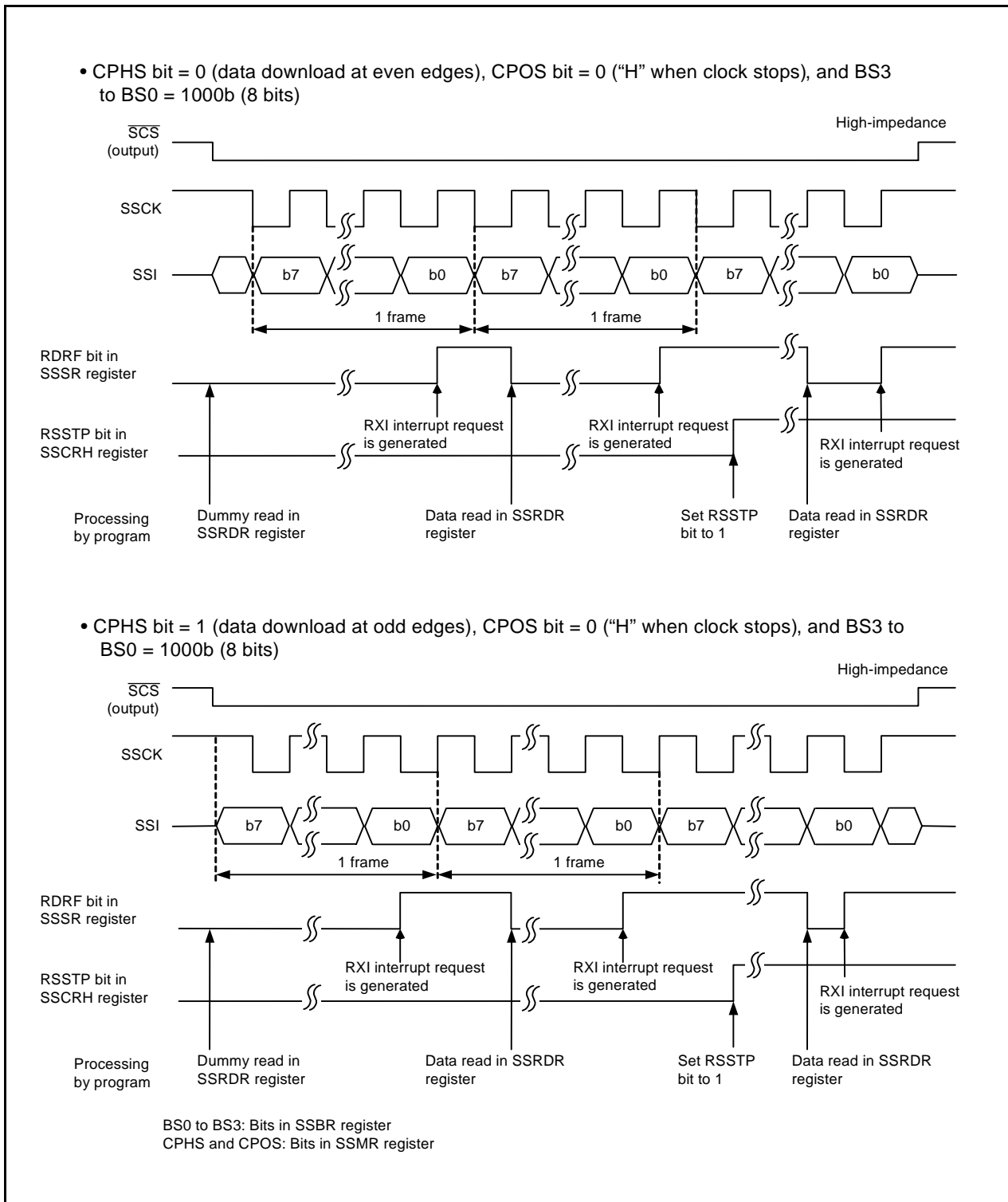

Figure 23.12 Example of Synchronous Serial Communication Unit Operation during Data Reception (4-Wire Bus Communication Mode, 8-Bit SSU Data Transfer Length)

23.5.4 $\overline{\text{SCS}}$ Pin Control and Arbitration

When setting the SSUMS bit in the SSMR2 register to 1 (4-wire bus communication mode) and the CSS1 bit in the SSMR2 register to 1 (functions as $\overline{\text{SCS}}$ output pin), set the MSS bit in the SSCRH register to 1 (operates as the master device) and check the arbitration of the $\overline{\text{SCS}}$ pin before starting serial transfer. If synchronous serial communication unit detects that the synchronized internal $\overline{\text{SCS}}$ signal is held “L” in this period, the CE bit in the SSSR register is set to 1 (conflict error) and the MSS bit is automatically set to 0 (operates as a slave device).

Figure 23.13 shows the Arbitration Check Timing.

Future transmit operations are not performed while the CE bit is set to 1. Set the CE bit to 0 (no conflict error) before starting transmission.

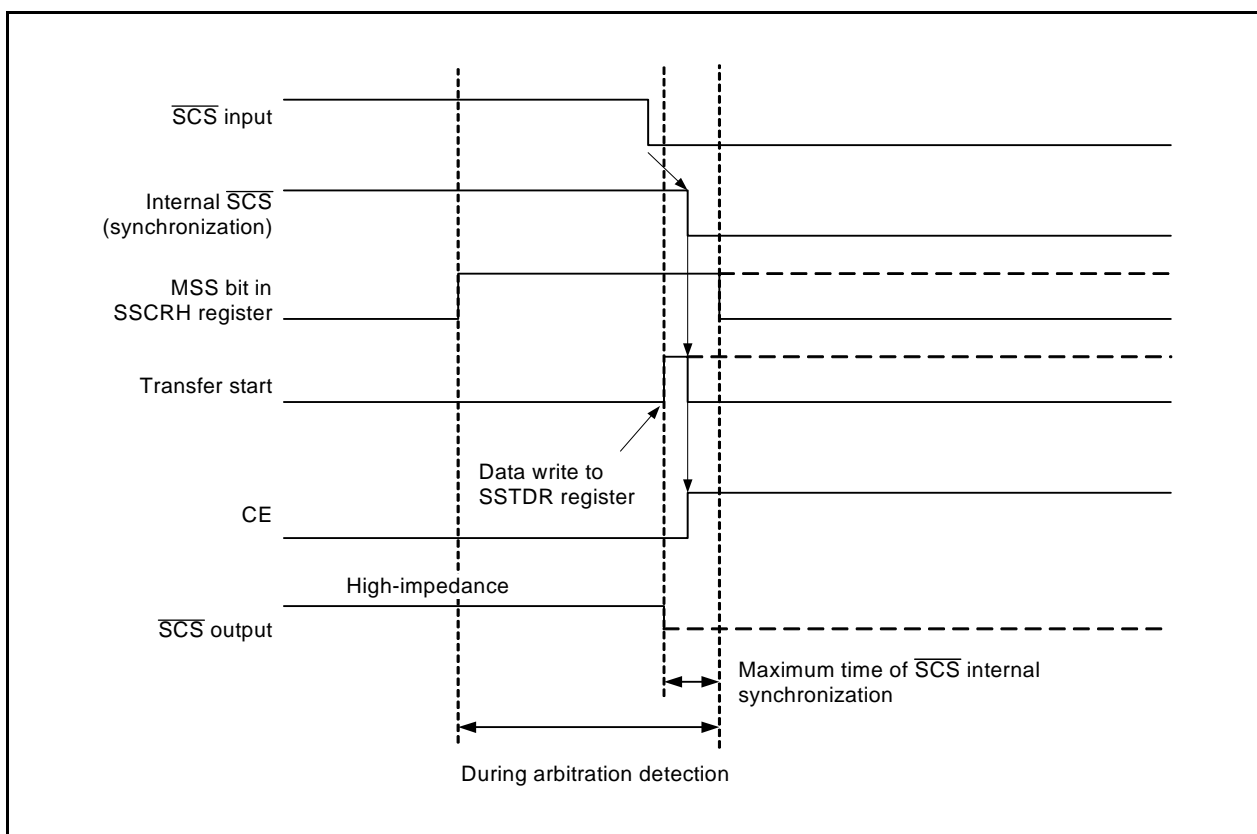

Figure 23.13 Arbitration Check Timing

24. Hardware LIN

The hardware LIN performs LIN communication in cooperation with timer RA and UART0.

24.1 Overview

The hardware LIN has the features listed below.

Figure 24.1 shows a Hardware LIN Block Diagram.

The wake-up function for each mode is detected using $\overline{INT1}$.

Master mode

- Synch Break generation
- Bus collision detection

Slave mode

- Synch Break detection
- Synch Field measurement
- Control function for Synch Break and Synch Field signal inputs to UART0
- Bus collision detection

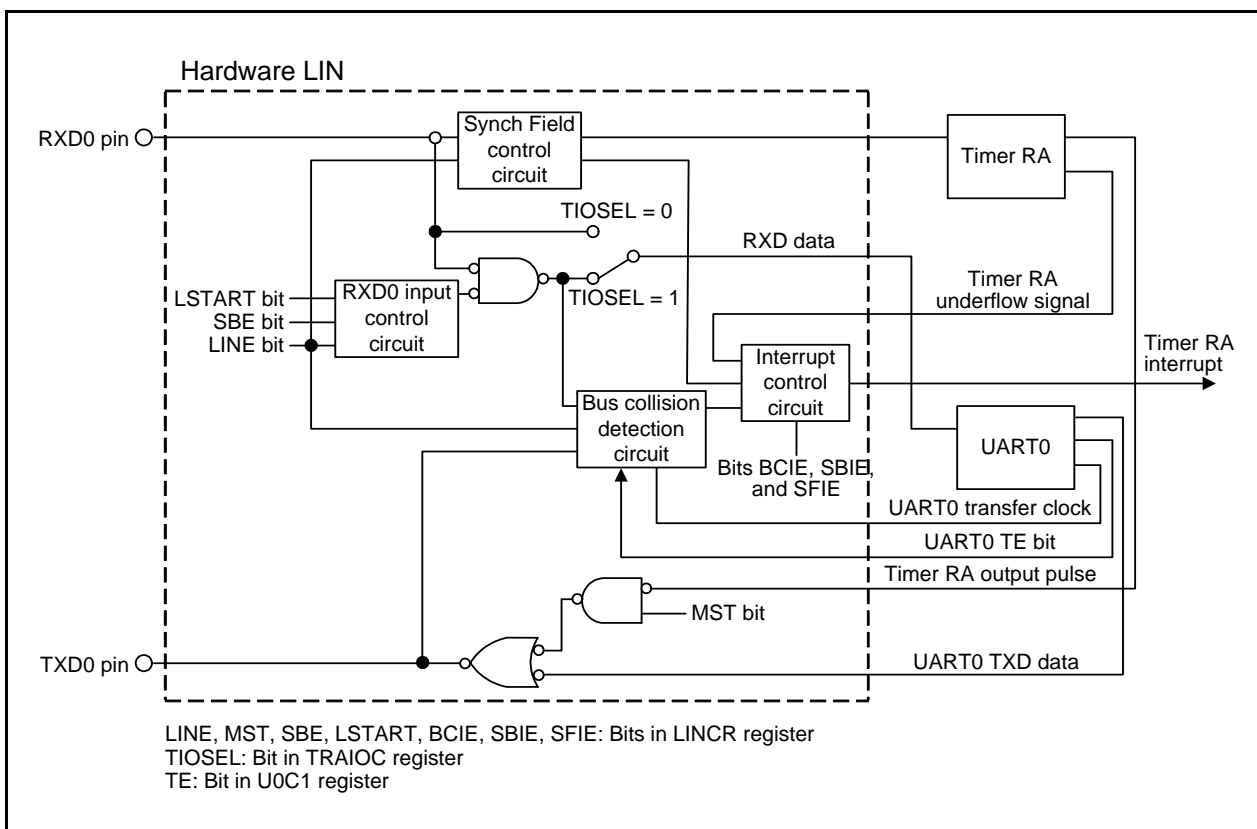

Figure 24.1 Hardware LIN Block Diagram

24.2 Input/Output Pins

The pin configuration for the hardware LIN is listed in Table 24.1.

Table 24.1 Hardware LIN Pin Configuration

Name	Pin Name	Assigned Pin	Input/Output	Function
Receive data input	RXD0	P1_5 (1)	Input	Receive data input pin for the hardware LIN
Transmit data output	TXD0	P1_4 (2)	Output	Transmit data output pin for the hardware LIN

Notes:

1. To use the hardware LIN, refer to **Table 7.18**.
2. To use the hardware LIN, set the TXD0SEL0 bit in the U0SR register to 1.

24.3 Registers

The hardware LIN contains the following registers:

- LIN Control Register 2 (LINCR2)
- LIN Control Register (LINCR)
- LIN Status Register (LINST)

24.3.1 LIN Control Register 2 (LINCR2)

Address 0105h

Bit	b7	b6	b5	b4	b3	b2	b1	b0
Symbol	—	—	—	—	—	—	—	BCE
After Reset	0	0	0	0	0	0	0	0

Bit	Symbol	Bit Name	Function	R/W
b0	BCE	Bus collision detection during Sync Break transmission enable bit	0: Bus collision detection disabled 1: Bus collision detection enabled	R/W
b1	—	Reserved bits	Set to 0.	R/W
b2	—			
b3	—			
b4	—	Nothing is assigned. If necessary, set to 0. When read, the content is 0.		—
b5	—			
b6	—			
b7	—			

24.3.2 LIN Control Register (LINCR)

Address 0106h

Bit	b7	b6	b5	b4	b3	b2	b1	b0
Symbol	LINE	MST	SBE	LSTART	RXDSF	BCIE	SBIE	SFIE
After Reset	0	0	0	0	0	0	0	0

Bit	Symbol	Bit Name	Function	R/W
b0	SFIE	Synch Field measurement-completed interrupt enable bit	0: Synch Field measurement-completed interrupt disabled 1: Synch Field measurement-completed interrupt enabled	R/W
b1	SBIE	Synch Break detection interrupt enable bit	0: Synch Break detection interrupt disabled 1: Synch Break detection interrupt enabled	R/W
b2	BCIE	Bus collision detection interrupt enable bit	0: Bus collision detection interrupt disabled 1: Bus collision detection interrupt enabled	R/W
b3	RXDSF	RXD0 input status flag	0: RXD0 input enabled 1: RXD0 input disabled	R
b4	LSTART	Synch Break detection start bit (1)	When this bit is set to 1, timer RA input is enabled and RXD0 input is disabled. When read, the content is 0.	R/W
b5	SBE	RXD0 input unmasking timing select bit (effective only in slave mode)	0: Unmasked after Synch Break detected 1: Unmasked after Synch Field measurement completed	R/W
b6	MST	LIN operation mode setting bit (2)	0: Slave mode (Synch Break detection circuit operation) 1: Master mode (timer RA output OR'ed with TXD0)	R/W
b7	LINE	LIN operation start bit	0: LIN operation stops 1: LIN operation starts (3)	R/W

Notes:

1. After setting the LSTART bit, confirm that the RXDSF flag is set to 1 before Synch Break input starts.
2. Before switching LIN operation modes, stop the LIN operation (LINE bit = 0) once.
3. Inputs to timer RA and UART0 are disabled immediately after the LINE bit is set to 1 (LIN operation starts). (Refer to **Figure 24.3 Header Field Transmission Flowchart Example (1)** and **Figure 24.7 Header Field Reception Flowchart Example (2)**.)

24.3.3 LIN Status Register (LINST)

Address 0107h

Bit	b7	b6	b5	b4	b3	b2	b1	b0
Symbol	—	—	B2CLR	B1CLR	B0CLR	BCDCT	SBDCT	SFDCT
After Reset	0	0	0	0	0	0	0	0

Bit	Symbol	Bit Name	Function	R/W
b0	SFDCT	Synch Field measurement-completed flag	When this bit is set to 1, Synch Field measurement is completed.	R
b1	SBDCT	Synch Break detection flag	when this bit is set to 1, Synch Break is detected or Synch Break generation is completed.	R
b2	BCDCT	Bus collision detection flag	When this bit is set to 1, bus collision is detected.	R
b3	B0CLR	SFDCT bit clear bit	When this bit is set to 1, the SFDCT bit is set to 0. When read, the content is 0.	R/W
b4	B1CLR	SBDCT bit clear bit	When this bit is set to 1, the SBDCT bit is set to 0. When read, the content is 0.	R/W
b5	B2CLR	BCDCT bit clear bit	When this bit is set to 1, the BCDCT bit is set to 0. When read, the content is 0.	R/W
b6	—	Nothing is assigned. If necessary, set to 0. When read, the content is 0.		—
b7	—			—

24.4 Function Description

24.4.1 Master Mode

Figure 24.2 shows an Operating Example during Header Field Transmission in master mode. Figures 24.3 and 24.4 show Examples of Header Field Transmission Flowchart.

During header field transmission, the hardware LIN operates as follows:

- (1) When 1 is written to the TSTART bit in the TRACR register for timer RA, a “L” level is output from the TXD0 pin for the period set in registers TRAPRE and TRA for timer RA.
- (2) When timer RA underflows, the TXD0 pin output is inverted and the SBDCT flag in the LINST register is set to 1. If the SBIE bit in the LINCRC register is set to 1, a timer RA interrupt is generated.
- (3) The hardware LIN transmits “55h” via UART0.
- (4) After the hardware LIN completes transmitting “55h”, it transmits an ID field via UART0.
- (5) After the hardware LIN completes transmitting the ID field, it performs communication for a response field.

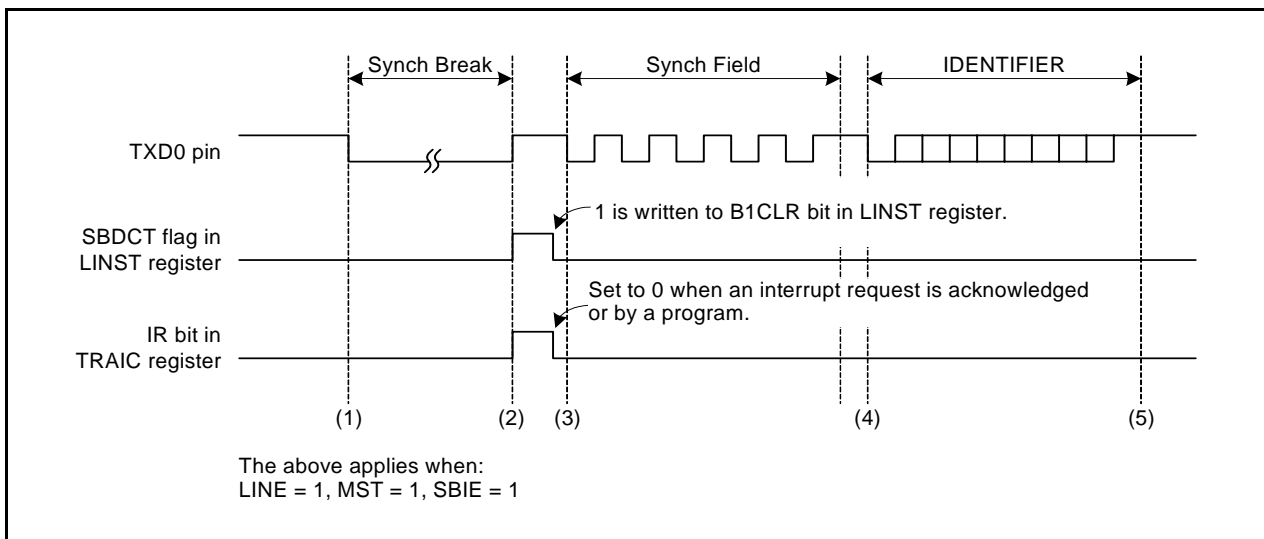

Figure 24.2 Operating Example during Header Field Transmission

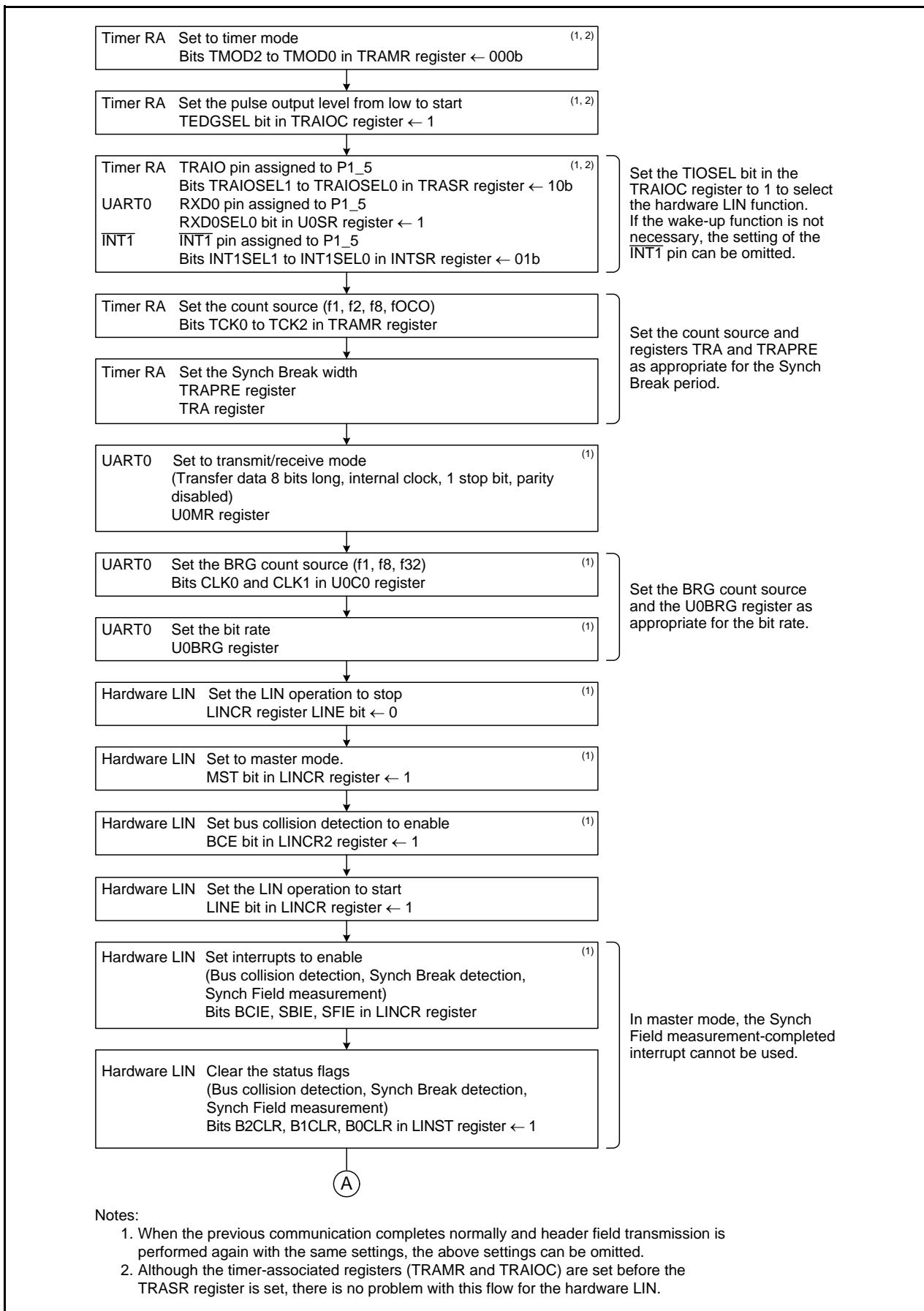

Figure 24.3 Header Field Transmission Flowchart Example (1)

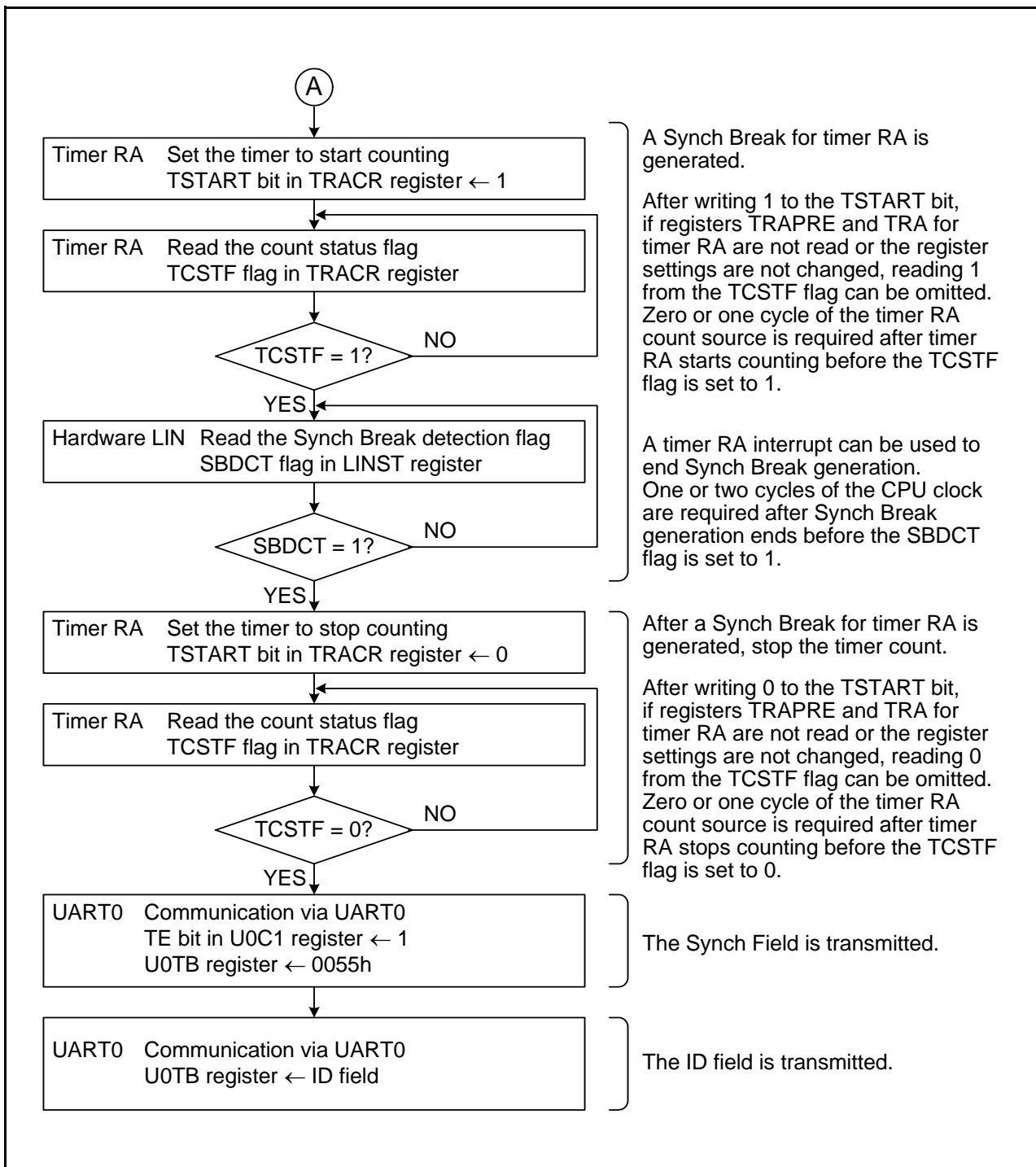

Figure 24.4 Header Field Transmission Flowchart Example (2)

24.4.2 Slave Mode

Figure 24.5 shows an Operating Example during Header Field Reception in slave mode. Figure 24.6 through Figure 24.8 show examples of Header Field Reception Flowchart.

During header field reception, the hardware LIN operates as follows:

- (1) When 1 is written to the LSTART bit in the LINCX register for the hardware LIN, Synch Break detection is enabled.
- (2) If a “L” level is input for a duration equal to or longer than the period set in timer RA, the hardware LIN detected it as a Synch Break. At this time, the SBDCT flag in the LINST register is set to 1. If the SBIE bit in the LINCX register is set to 1, a timer RA interrupt is generated. Then the hardware LIN enters the Synch Field measurement.
- (3) The hardware LINA receives a Synch Field (55h) and measures the period of the start bit and bits 0 to 6 is using timer RA. At this time, whether to input the Synch Field signal to RXD0 of UART0 can be selected by the SBE bit in the LINCX register.
- (4) When the Synch Field measurement is completed, the SFDCT flag in the LINST register is set to 1. If the SFIE bit in the LINCX register is set to 1, a timer RA interrupt is generated.
- (5) After the Synch Field measurement is completed, a transfer rate is calculated from the timer RA count value. The rate is set in UART0 and registers TRAPRE and TRA for timer RA are set again. Then the hardware LIN receives an ID field via UART0.
- (6) After the hardware LIN completes receiving the ID field, it performs communication for a response field.

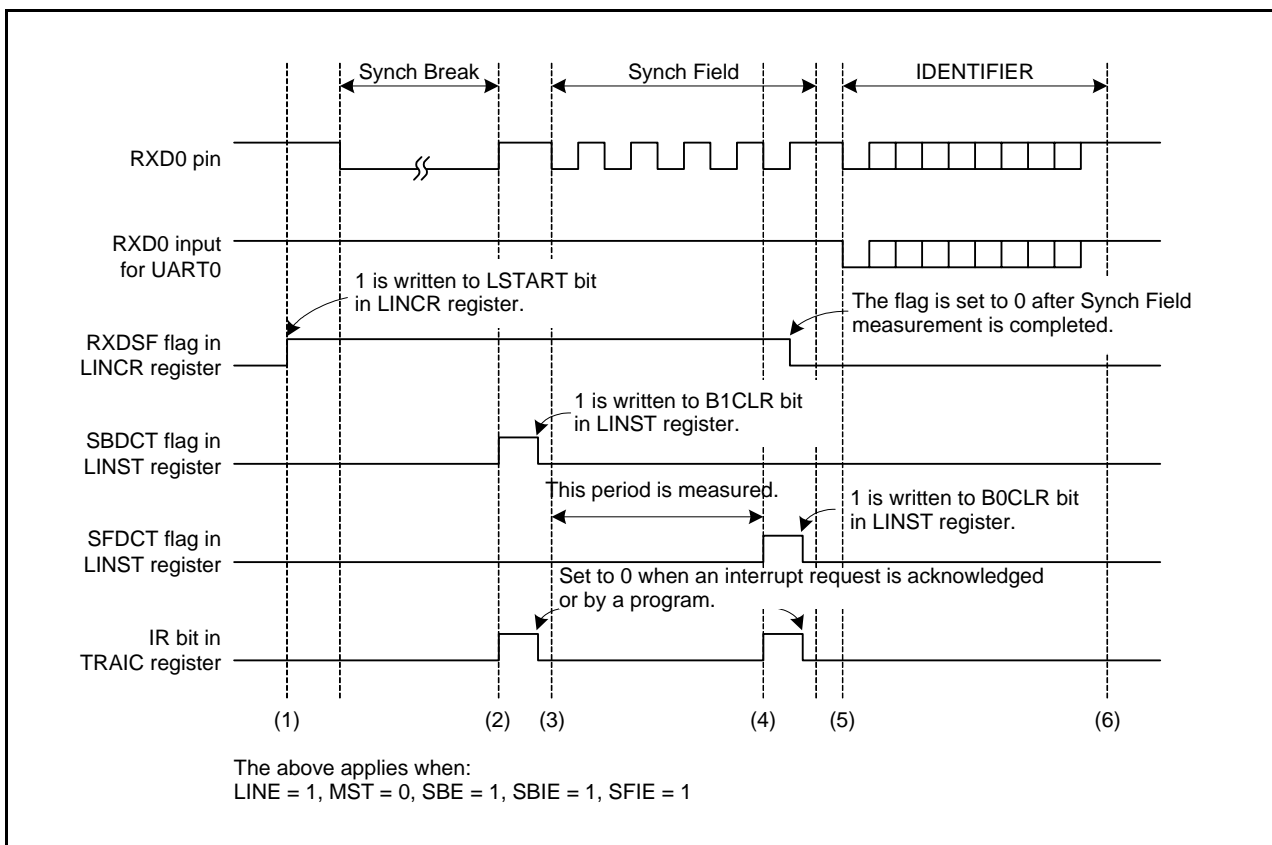

Figure 24.5 Operating Example during Header Field Reception

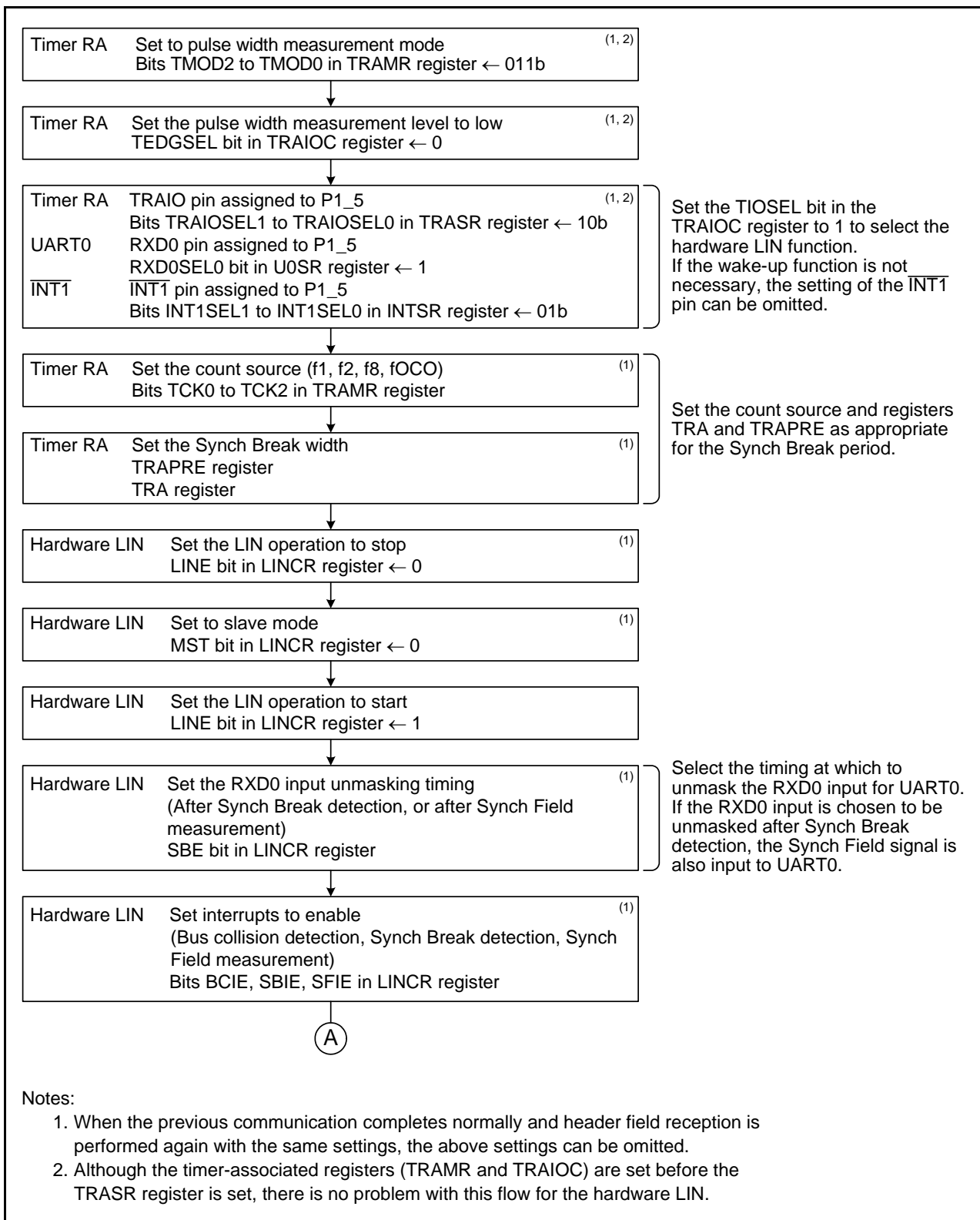

Figure 24.6 Header Field Reception Flowchart Example (1)

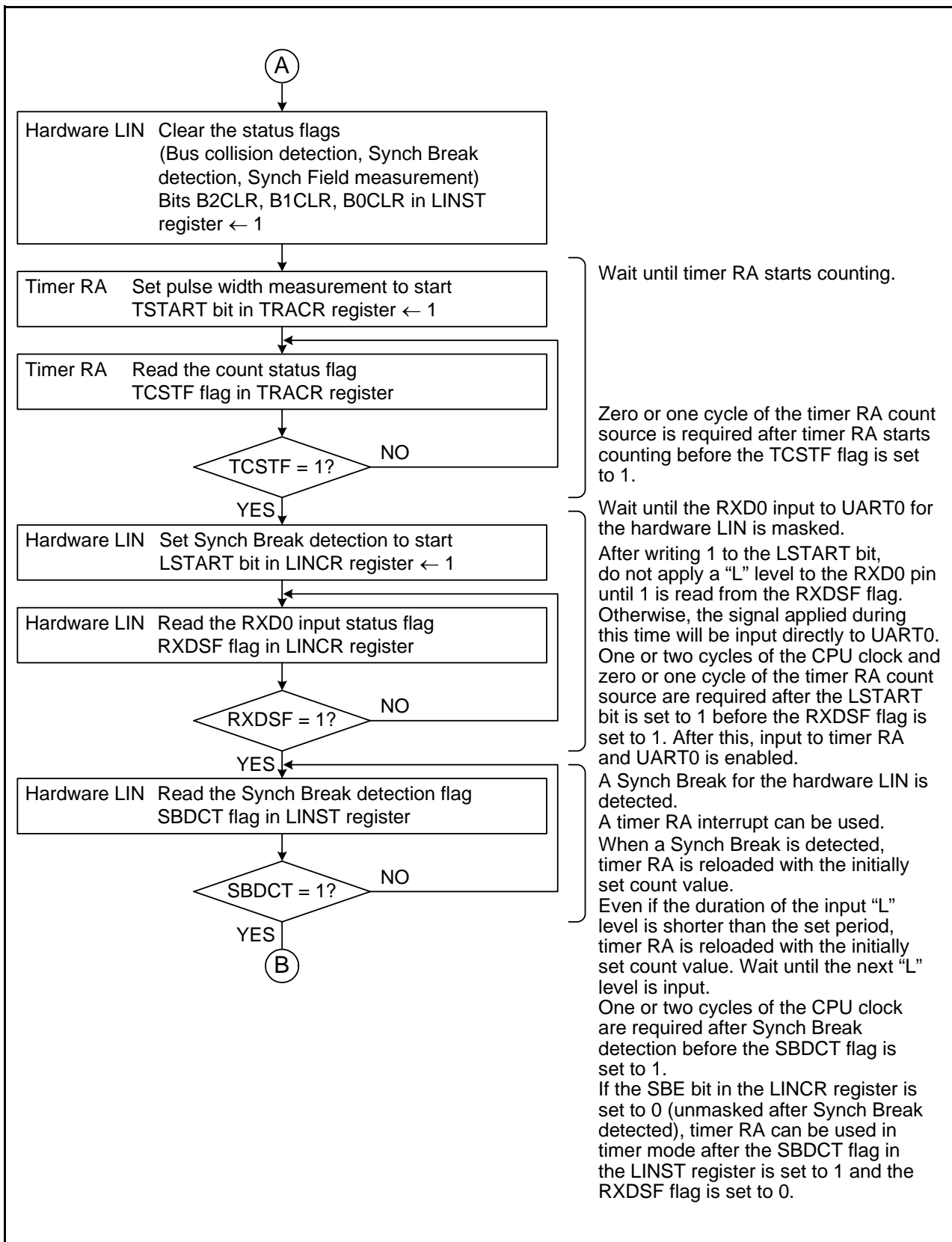

Figure 24.7 Header Field Reception Flowchart Example (2)

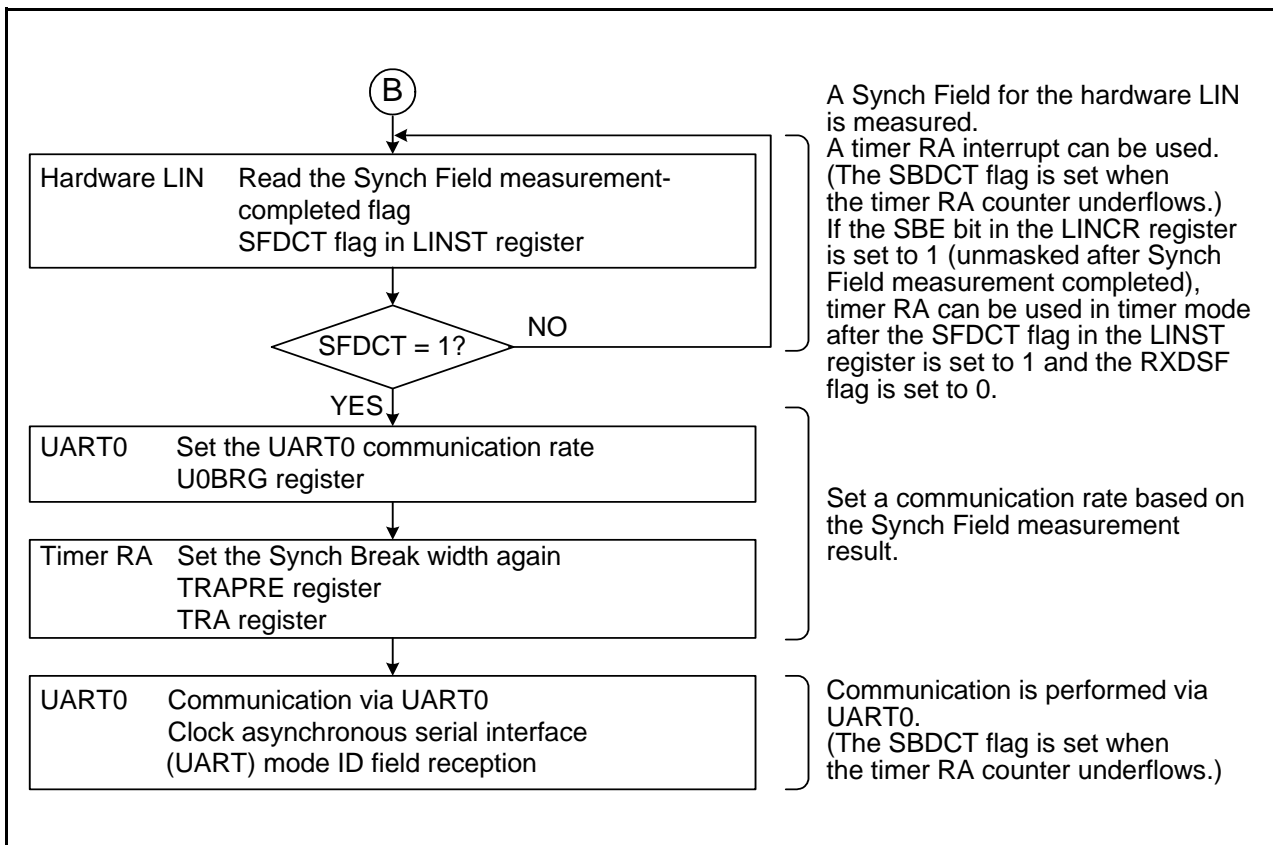

Figure 24.8 Header Field Reception Flowchart Example (3)

24.4.3 Bus Collision Detection Function

The bus collision detection function can be used if UART0 is enabled for transmission (TE bit in U0C1 register = 1). To detect a bus collision during Synch Break transmission, set the BCE bit in the LINCR2 register to 1 (bus collision detection enabled).

Figure 24.9 shows an Operating Example When Bus Collision is Detected.

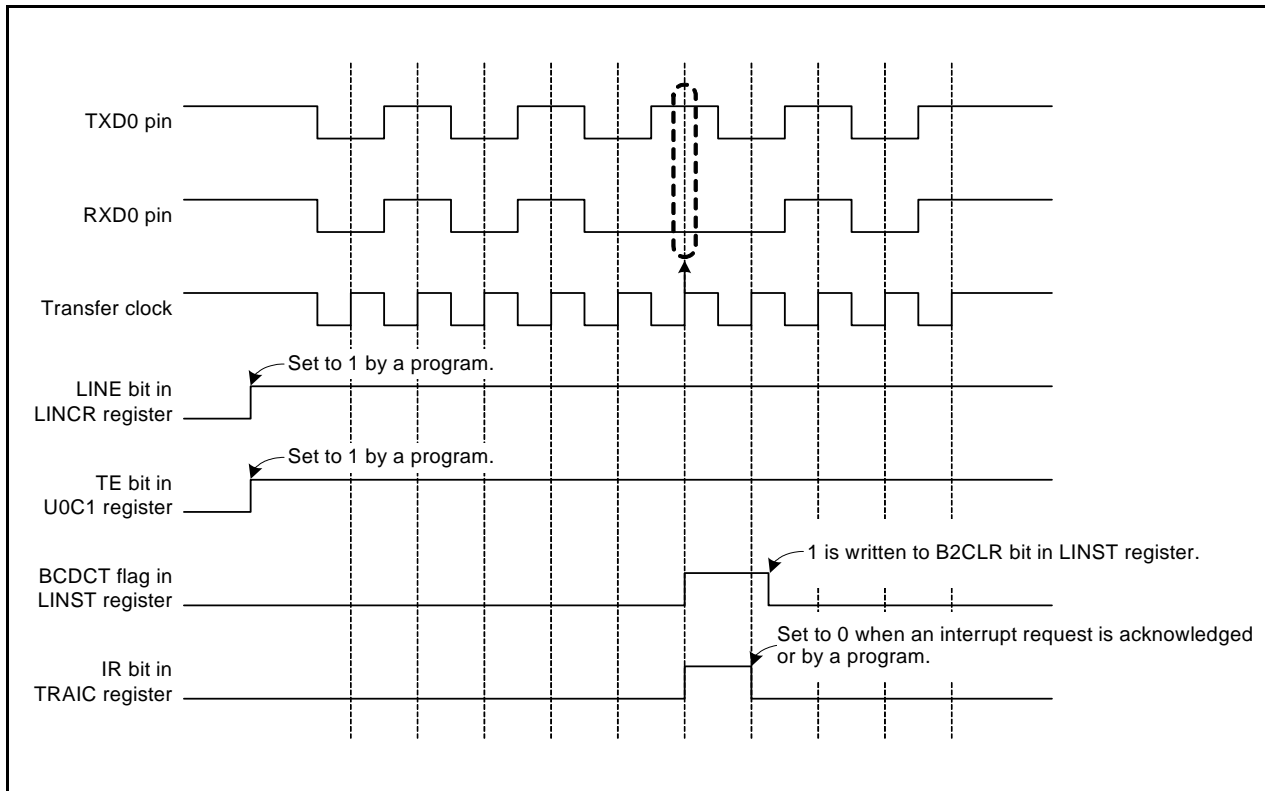

Figure 24.9 Operating Example When Bus Collision is Detected

24.4.4 Hardware LIN End Processing

Figure 24.10 shows an Example of Hardware LIN Communication Completion Flowchart. Use the following timing for hardware LIN end processing:

- If the hardware bus collision detection function is used
Perform hardware LIN end processing after checksum transmission completes.
- If the bus collision detection function is not used
Perform hardware LIN end processing after header field transmission and reception complete.

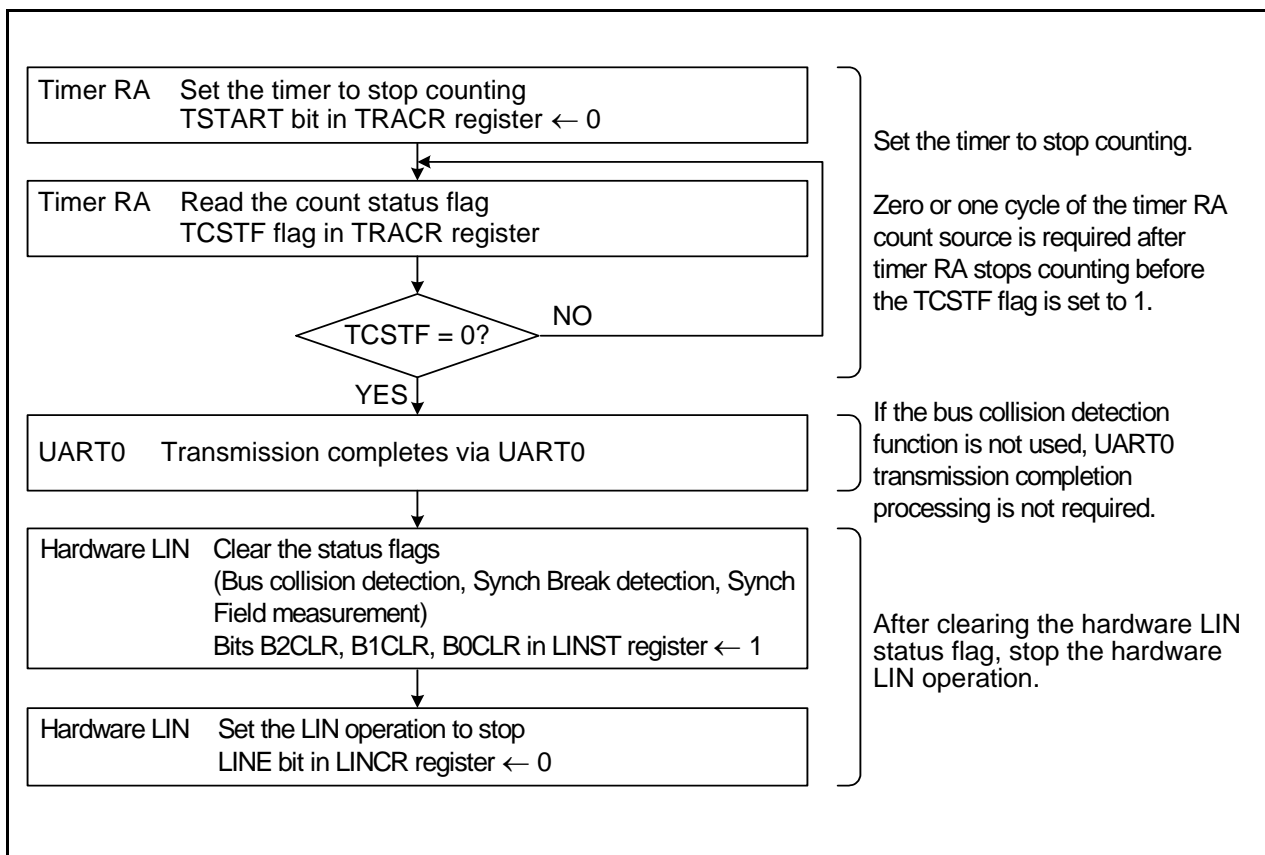

Figure 24.10 Example of Hardware LIN Communication Completion Flowchart

24.5 Interrupt Requests

There are four interrupt requests generated by the hardware LIN: Synch Break detection, Completion of Synch Break generation, Completion of Synch Field measurement, and bus collision detection. These interrupts are shared with timer RA.

Table 24.2 lists the Hardware LIN Interrupt Requests.

Table 24.2 Hardware LIN Interrupt Requests

Interrupt Request	Status Flag	Interrupt Source
Synch Break detection	SBDCT	Generated when timer RA underflows after the “L” level duration for the RXD0 input is measured, or when a “L” level is input for a duration longer than the Synch Break period during communication.
Completion of Synch Break generation		Generated when a “L” level output to TXD0 for the duration set by timer RA is completed.
Completion of Synch Field measurement	SFDCT	Generated when measurement for 6 bits of the Lynch Field by timer RA is completed.
Bus collision detection	BCDCT	Generated when the RXD0 input and TXD0 output values are different at data latch timing while UART0 is enabled for transmission.

24.6 Notes on Hardware LIN

For the time-out processing of the header and response fields, use another timer to measure the duration of time with a Synch Break detection interrupt as the starting point.

25. A/D Converter

The A/D converter consists of one 10-bit successive approximation A/D converter circuit with a capacitive coupling amplifier. The analog input shares pins P0_0 to P0_7, and P1_0 to P1_3.

25.1 Overview

Table 25.1 lists the A/D Converter Performance. Figure 25.1 shows a Block Diagram of A/D Converter.

Table 25.1 A/D Converter Performance

Item	Performance
A/D conversion method	Successive approximation (with capacitive coupling amplifier)
Analog input voltage ⁽¹⁾	0 V to AVCC
Operating clock ϕ_{AD} ⁽²⁾	fAD, fAD divided by 2, fAD divided by 4, fAD divided by 8 (fAD=f1 or fOCO-F)
Resolution	8 bits or 10 bits selectable
Absolute accuracy	AVCC = Vref = 5 V, ϕ_{AD} = 20 MHz <ul style="list-style-type: none"> • 8-bit resolution ± 2 LSB • 10-bit resolution ± 3 LSB AVCC = Vref = 3.0 V, ϕ_{AD} = 10 MHz <ul style="list-style-type: none"> • 8-bit resolution ± 2 LSB • 10-bit resolution ± 5 LSB
Operating mode	One-shot mode, repeat mode 0, repeat mode 1, single sweep mode, and repeat sweep mode
Analog input pin	12 pins (AN0 to AN11)
A/D conversion start condition	<ul style="list-style-type: none"> • Software trigger • Timer RD • Timer RC • External trigger (Refer to 25.3.3 A/D Conversion Start Condition.)
Conversion rate per pin (ϕ_{AD} = fAD)	Minimum 44 ϕ_{AD} cycles

Notes:

1. When the analog input voltage is over the reference voltage, the A/D conversion result will be 3FFh in 10-bit mode and FFh in 8-bit mode.
2. Refer to **Table 30.4 A/D Converter Characteristics** for the operating clock ϕ_{AD} .
3. The conversion rate per pin is minimum 44 ϕ_{AD} cycles for 8-bit and 10-bit resolution.

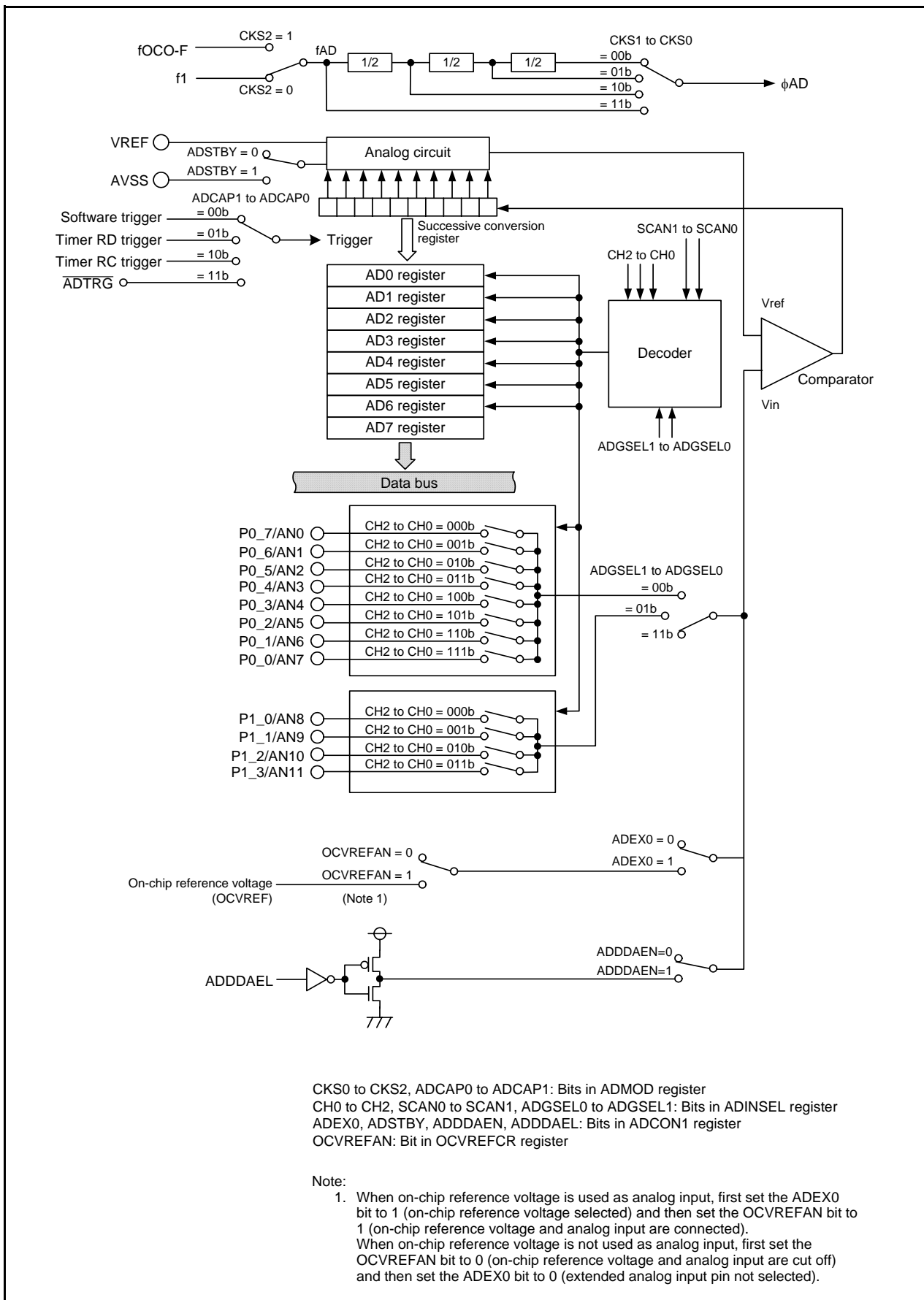

Figure 25.1 Block Diagram of A/D Converter

25.2 Registers

25.2.1 On-Chip Reference Voltage Control Register (OCVREFCR)

Address 0026h

Bit	b7	b6	b5	b4	b3	b2	b1	b0
Symbol	—	—	—	—	—	—	—	OCVREFAN
After Reset	0	0	0	0	0	0	0	0

Bit	Symbol	Bit Name	Function	R/W
b0	OCVREFAN	On-chip reference voltage to analog input connect bit ⁽¹⁾	0: On-chip reference voltage and analog input are cut off 1: On-chip reference voltage and analog input are connected	R/W
b1	—	Reserved bits	Set to 0.	R/W
b2	—			
b3	—			
b4	—			
b5	—			
b6	—			
b7	—			

Note:

- When on-chip reference voltage is used as analog input, first set the ADEX0 bit in the ADCON1 register to 1 (on-chip reference voltage selected) and then set the OCVREFAN bit to 1 (on-chip reference voltage and analog input are connected).
When on-chip reference voltage is not used as analog input, first set the OCVREFAN bit to 0 (on-chip reference voltage and analog input are cut off) and then set the ADEX0 bit to 0 (extended analog input pin not selected).

Set the PRC3 bit in the PRCR register to 1 (write enabled) before rewriting the OCVREFCR register.

If the contents of the OCVREFCR register are rewritten during A/D conversion, the conversion result is undefined.

25.2.2 A/D Register i (ADi) (i = 0 to 7)

Address 00C1h to 00C0h (AD0), 00C3h to 00C2h (AD1), 00C5h to 00C4h (AD2),
00C7h to 00C6h (AD3), 00C9h to 00C8h (AD4), 00CBh to 00CAh (AD5),
00CDh to 00CCh (AD6), 00CFh to 00CEh (AD7)

Bit	b7	b6	b5	b4	b3	b2	b1	b0
Symbol	—	—	—	—	—	—	—	—
After Reset	X	X	X	X	X	X	X	X

Bit	b15	b14	b13	b12	b11	b10	b9	b8
Symbol	—	—	—	—	—	—	—	—
After Reset	0	0	0	0	0	0	X	X

Bit	Function		R/W
	10-Bit Mode (BITS Bit in ADCON1 Register = 1)	8-Bit Mode (BITS Bit in ADCON1 Register = 0)	
b0	8 low-order bits in A/D conversion result	A/D conversion result	R
b1			
b2			
b3			
b4			
b5			
b6			
b7			
b8	2 high-order bits in A/D conversion result	When read, the content is 0.	R
b9			
b10	Nothing is assigned. If necessary, set to 0. When read, the content is 0.		—
b11			
b12			
b13			
b14			
b15	Reserved bit	When read, the content is undefined.	R

If the contents of the ADCON1, ADMOD, ADINSEL, or OCVREFCR register are written during A/D conversion, the conversion result is undefined.

When using the A/D converter in 10-bit mode, repeat mode 0, repeat mode 1, or repeat sweep mode, access the ADi register in 16-bit units. Do not access it in 8-bit units.

25.2.3 A/D Mode Register (ADM0D)

Address 00D4h

Bit	b7	b6	b5	b4	b3	b2	b1	b0
Symbol	ADCAP1	ADCAP0	MD2	MD1	MD0	CKS2	CKS1	CKS0
After Reset	0	0	0	0	0	0	0	0

Bit	Symbol	Bit Name	Function	R/W
b0	CKS0	Division select bit	b1 b0 0 0: fAD divided by 8 0 1: fAD divided by 4 1 0: fAD divided by 2 1 1: fAD divided by 1 (no division)	R/W
b1	CKS1			R/W
b2	CKS2	Clock source select bit (1)	0: Selects f1 1: Selects fOCO-F	R/W
b3	MD0	A/D operating mode select bit	b5 b4 b3 0 0 0: One-shot mode 0 0 1: Do not set. 0 1 0: Repeat mode 0 0 1 1: Repeat mode 1 1 0 0: Single sweep mode 1 0 1: Do not set. 1 1 0: Repeat sweep mode 1 1 1: Do not set.	R/W
b4	MD1			R/W
b5	MD2			R/W
b6	ADCAP0	A/D conversion trigger select bit	b7 b6 0 0: A/D conversion starts by software trigger (ADST bit in ADCON0 register) 0 1: A/D conversion starts by conversion trigger from timer RD 1 0: A/D conversion starts by conversion trigger from timer RC 1 1: A/D conversion starts by external trigger ($\overline{\text{ADTRG}}$)	R/W
b7	ADCAP1			R/W

Note:

- When the CKS2 bit is changed, wait for 3 ϕ AD cycles or more before starting A/D conversion.

If the ADM0D register is rewritten during A/D conversion, the conversion result is undefined.

25.2.4 A/D Input Select Register (ADINSEL)

Address 00D5h

Bit	b7	b6	b5	b4	b3	b2	b1	b0
Symbol	ADGSEL1	ADGSEL0	SCAN1	SCAN0	—	CH2	CH1	CH0
After Reset	1	1	0	0	0	0	0	0

Bit	Symbol	Bit Name	Function	R/W
b0	CH0	Analog input pin select bit	Refer to Table 25.2 Analog Input Pin Selection	R/W
b1	CH1			R/W
b2	CH2			R/W
b3	—	Reserved bit	Set to 0.	R/W
b4	SCAN0	A/D sweep pin count select bit	^{b5 b4} 0 0: 2 pins 0 1: 4 pins 1 0: 6 pins 1 1: 8 pins	R/W
b5	SCAN1			R/W
b6	ADGSEL0	A/D input group select bit	^{b7 b6} 0 0: Port P0 group selected 0 1: Port P1 group selected 1 0: Do not set. 1 1: Port group not selected	R/W
b7	ADGSEL1			R/W

If the ADINSEL register is rewritten during A/D conversion, the conversion result is undefined.

Table 25.2 Analog Input Pin Selection

Bits CH2 to CH0	Bits ADGSEL1, ADGSEL0 = 00b	Bits ADGSEL1, ADGSEL0 = 01b
000b	AN0	AN8
001b	AN1	AN9
010b	AN2	AN10
011b	AN3	AN11
100b	AN4	Do not set.
101b	AN5	
110b	AN6	
111b	AN7	

25.2.5 A/D Control Register 0 (ADCON0)

Address 00D6h

Bit	b7	b6	b5	b4	b3	b2	b1	b0
Symbol	—	—	—	—	—	—	—	ADST
After Reset	0	0	0	0	0	0	0	0

Bit	Symbol	Bit Name	Function	R/W
b0	ADST	A/D conversion start flag	0: Stop A/D conversion 1: Start A/D conversion	R/W
b1	—	Nothing is assigned. If necessary, set to 0. When read, the content is 0.		—
b2	—			
b3	—			
b4	—			
b5	—			
b6	—			
b7	—			

ADST Bit (A/D conversion start flag)

[Conditions for setting to 1]

When A/D conversion starts and while A/D conversion is in progress.

[Condition for setting to 0]

When A/D conversion stops.

25.2.6 A/D Control Register 1 (ADCON1)

Address 00D7h

Bit	b7	b6	b5	b4	b3	b2	b1	b0
Symbol	ADDDAEL	ADDDAEN	ADSTBY	BITS	—	—	—	ADEX0
After Reset	0	0	0	0	0	0	0	0

Bit	Symbol	Bit Name	Function	R/W
b0	ADEX0	Extended analog input pin select bit ⁽¹⁾	0: Extended analog input pin not selected 1: On-chip reference voltage selected ^(2, 6, 7)	R/W
b1	—	Reserved bits	Set to 0.	R/W
b2	—			
b3	—			
b4	BITS			
b5	ADSTBY	A/D standby bit ⁽³⁾	0: A/D operation stops (standby) ⁽⁴⁾ 1: A/D operation enabled	R/W
b6	ADDDAEN	A/D open-circuit detection assist function enable bit ^(5, 7)	0: Disabled 1: Enabled	R/W
b7	ADDDAEL	A/D open-circuit detection assist method select bit ⁽⁵⁾	0: Discharge before conversion 1: Precharge before conversion	R/W

Notes:

- When on-chip reference voltage is used as analog input, first set the ADEX0 bit to 1 (on-chip reference voltage selected) and then set the OCVREFAN bit in the OCVREFCR register to 1 (on-chip reference voltage and analog input are connected).
When on-chip reference voltage is not used as analog input, first set the OCVREFAN bit to 0 (on-chip reference voltage and analog input are cut off) and then set the ADEX0 bit to 0 (extended analog input pin not selected).
- Do not set to 1 (A/D conversion using comparison reference voltage as input) in single sweep mode or repeat sweep mode.
- When the ADSTBY bit is changed from 0 (A/D operation stops) to 1 (A/D operation enabled), wait for 1 ϕ AD cycle or more before starting A/D conversion.
- Stop the A/D function before setting to standby. When the ADSTBY bit is set to 1 (standby), any access to the A/D associated registers (addresses 00C0h to 00CFh, and 00D4h to 00D7h) is disabled.
However, only the ADSTBY bit can be accessed in the ADCON1 register at address 00D7h.
- To enable the A/D open-circuit detection assist function, select the conversion start state with the ADDDAEL bit after setting the ADDDAEN bit to 1 (enabled).
The conversion result with an open circuit varies with external circuits. Careful evaluation should be performed according to the system before using this function.
- When on-chip reference voltage is used (ADEX0 = 1), set bits CH2 to CH0 in the ADINSEL register to 000b.
- When on-chip reference voltage is used (ADEX0 = 1), set the ADDDAEN bit to 0 (A/D open-circuit detection assist function disabled).

If the ADCON1 register is rewritten during A/D conversion, the conversion result is undefined.

25.3 Common Items for Multiple Modes

25.3.1 Input/Output Pins

The analog input shares pins P0_0 to P0_7, and P1_0 to P1_3 in AN0 to AN11.
 When using the AN_i (i = 0 to 11) pin as input, set the corresponding port direction bit to 0 (input mode).
 After changing the A/D operating mode, select an analog input pin again.

25.3.2 A/D Conversion Cycles

Figure 25.2 shows a Timing Diagram of A/D Conversion. Figure 25.3 shows the A/D Conversion Cycles ($\phi_{AD} = f_{AD}$).

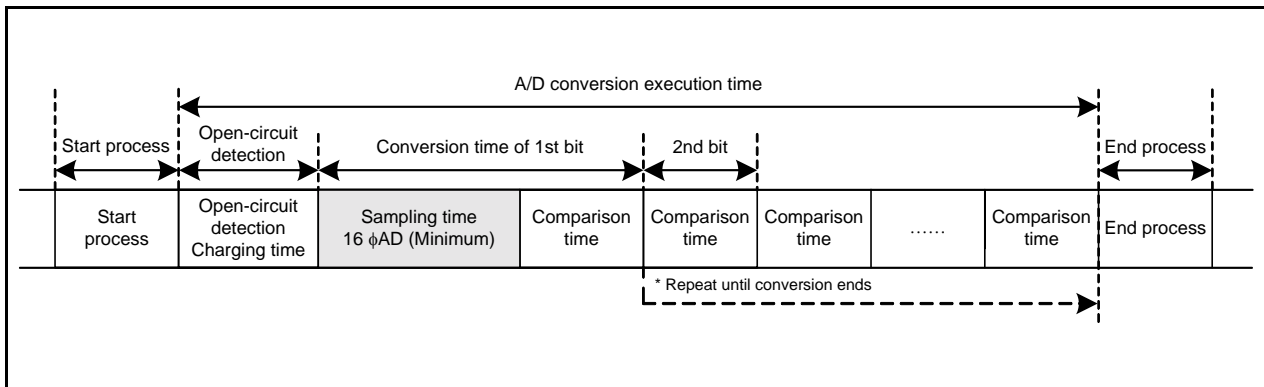

Figure 25.2 Timing Diagram of A/D Conversion

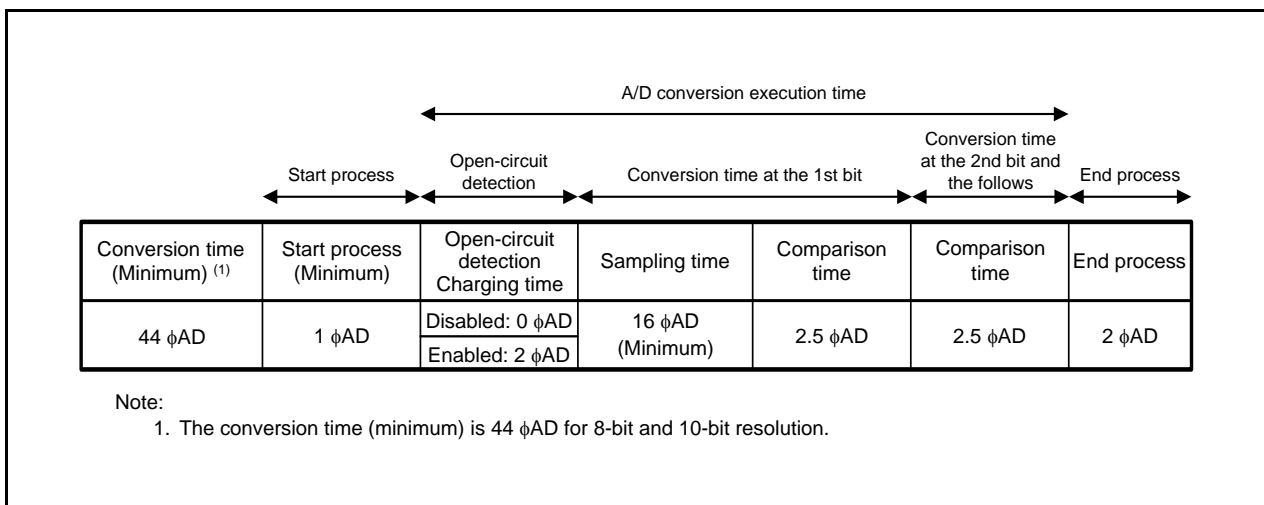

Figure 25.3 A/D Conversion Cycles ($\phi_{AD} = f_{AD}$)

Note:
 1. The conversion time (minimum) is 44 ϕ_{AD} for 8-bit and 10-bit resolution.

Table 25.3 shows the Number of Cycles for A/D Conversion Items. The A/D conversion time is defined as follows.

The start process time varies depending on which ϕ_{AD} is selected.

When 1 (A/D conversion starts) is written to the ADST bit in the ADCON0 register, an A/D conversion starts after the start process time has elapsed. Reading the ADST bit before the A/D conversion returns 0 (A/D conversion stops).

In the modes where an A/D conversion is performed on multiple pins or multiple times, the between-execution process time is inserted between the A/D conversion execution time for one pin and the next A/D conversion time.

In one-shot mode and single sweep mode, the ADST bit is set to 0 during the end process time and the last A/D conversion result is stored in the ADi register at the same time.

- In on-shot mode
Start process time + A/D conversion execution time + end process time
- When two pins are selected in single sweep mode
Start process time + (A/D conversion execution time + between-execution process time + A/D conversion execution time) + end process time

Table 25.3 Number of Cycles for A/D Conversion Items

A/D Conversion Item		Number of Cycles
Start process time	$\phi_{AD} = f_{AD}$	1 or 2 fAD cycles
	$\phi_{AD} = f_{AD}$ divided by 2	2 or 3 fAD cycles
	$\phi_{AD} = f_{AD}$ divided by 4	3 or 4 fAD cycles
	$\phi_{AD} = f_{AD}$ divided by 8	5 or 6 fAD cycles
A/D conversion execution time	Open-circuit detection disabled	40 ϕ_{AD} cycles + 1 to 3 fAD cycles
	Open-circuit detection enabled	42 ϕ_{AD} cycles + 1 to 3 fAD cycles
Between-execution process time		1 ϕ_{AD} cycle
End process time		2 or 3 fAD cycles

25.3.3 A/D Conversion Start Condition

A software trigger, trigger from timer RD or timer RC, and external trigger are used as A/D conversion start triggers.

Figure 25.4 shows the Block Diagram of A/D Conversion Start Control Unit.

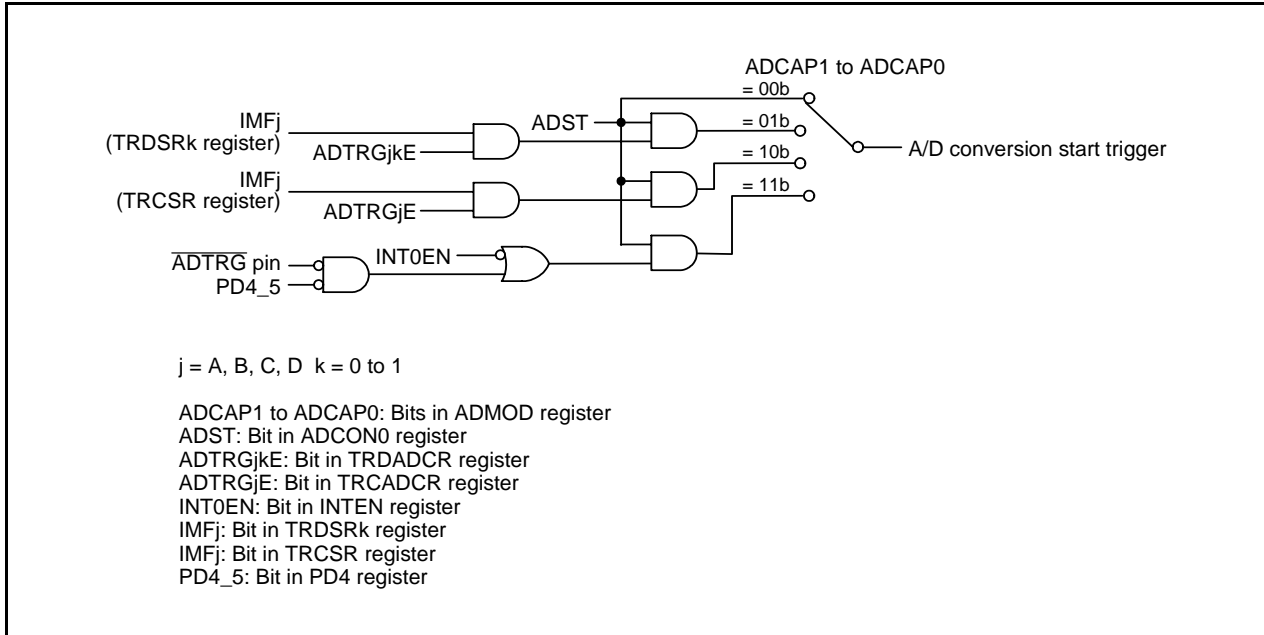

Figure 25.4 Block Diagram of A/D Conversion Start Control Unit

25.3.3.1 Software Trigger

A software trigger is selected when bits ADCAP1 to ADCAP0 in the ADMOD register are set to 00b (software trigger).

The A/D conversion starts when the ADST bit in the ADCON0 register is set to 1 (A/D conversion starts).

25.3.3.2 Trigger from Timer RD

This trigger is selected when bits ADCAP1 to ADCAP0 in the ADMOD register are set to 01b (timer RD).

To use this function, make sure the following conditions are met.

- Bits ADCAP1 to ADCAP0 in the ADMOD register are set to 01b (timer RD).
- Timer RD is used in the output compare function (timer mode, PWM mode, reset synchronous PWM mode, complementary PWM mode, and PWM3 mode).
- The ADTRGjkE bit (j = A, B, C, D, k = 0 or 1) in the TRDADCR register is set to 1 (A/D trigger occurs at compare match with TRDGRjk register).
- The ADST bit in the ADCON0 register is set to 1 (A/D conversion starts).

When the IMFj bit in the TRDSRk register is changed from 0 to 1, A/D conversion starts.

Refer to **20. Timer RD**, **20.4 Timer Mode (Output Compare Function)**, **20.5 PWM Mode**, **20.6 Reset Synchronous PWM Mode**, **20.7 Complementary PWM Mode**, **20.8 PWM3 Mode** for the details of timer RD and the output compare function (timer mode, PWM mode, reset synchronous PWM mode, complementary PWM mode, and PWM3 mode).

25.3.3.3 Trigger from Timer RC

This trigger is selected when bits ADCAP1 to ADCAP0 in the ADMOD register are set to 10b (timer RC). To use this function, make sure the following conditions are met.

- Bits ADCAP1 to ADCAP0 in the ADMOD register are set to 10b (timer RC).
- Timer RC is used in the output compare function (timer mode, PWM mode, PWM2 mode).
- The ADTRGjE bit (j = A, B, C, D) in the TRCADCR register is set to 1 (A/D trigger occurs at compare match with TRCGRj register).
- The ADST bit in the ADCON0 register is set to 1 (A/D conversion starts).

When the IMFj bit in the TRCSR register is changed from 0 to 1, A/D conversion starts.

Refer to **19. Timer RC**, **19.5 Timer Mode (Output Compare Function)**, **19.6 PWM Mode**, **19.7 PWM2 Mode** for the details of timer RC and the output compare function (timer mode, PWM mode, and PWM2 mode).

25.3.3.4 External Trigger

This trigger is selected when bits ADCAP1 to ADCAP0 in the ADMOD register are set to 11b (external trigger ($\overline{\text{ADTRG}}$)).

To use this function, make sure the following conditions are met.

- Bits ADCAP1 to ADCAP0 in the ADMOD register are set to 11b (external trigger ($\overline{\text{ADTRG}}$)).
- Set the INT0EN bit in the INTEN register to 1 ($\overline{\text{INT0}}$ input enabled) and the INT0PL bit to 0 (one edge), and set the POL bit in the INT0IC register to 0 (falling edge selected).
- Set the PD4_5 bit in the PD4 register to 0 (input mode).
- Select the $\overline{\text{INT0}}$ digital filter by bits INT0F1 to INT0F0 in the INTF register.
- The ADST bit in the ADCON0 register is set to 1 (A/D conversion starts).

The IR bit in the INT0IC register is set to 1 (interrupt requested) in accordance with the setting of the POL bit in the INT0IC register and the INT0PL bit in the INTEN register and a change in the $\overline{\text{ADTRG}}$ pin input (refer to **11.8 Notes on Interrupts**).

For details on interrupts, refer to **11. Interrupts**.

When the $\overline{\text{ADTRG}}$ pin input is changed from “H” to “L” under the above conditions, A/D conversion starts.

25.3.4 A/D Conversion Result

The A/D conversion result is stored in the ADi register (i = 0 to 7). The register where the result is stored varies depending on the A/D operating mode used. The contents of the ADi register are undefined after a reset. Values cannot be written to the ADi register.

In repeat mode 0, no interrupt request is generated. After the first AD conversion is completed, determine if the A/D conversion time has elapsed by a program.

In one-shot mode, repeat mode 1, single sweep mode, and repeat sweep mode, an interrupt request is generated at certain times, such as when an A/D conversion completes (the IR bit in the ADIC register is set to 1).

However, in repeat mode 1 and repeat sweep mode, A/D conversion continues after an interrupt request is generated. Read the ADi register before the next A/D conversion is completed, since at completion the ADi register is rewritten with the new value.

In one-shot mode and single sweep mode, when bits ADCAP1 to ADCAP0 in the ADMOD register is set to 00b (software trigger), the ADST bit in the ADCON0 register is used to determine whether the A/D conversion or sweep has completed.

During an A/D conversion operation, if the ADST bit in the ADCON0 register is set to 0 (A/D conversion stops) by a program to forcibly terminate A/D conversion, the conversion result of the A/D converter is undefined and no interrupt is generated. The value of the ADi register before A/D conversion may also be undefined.

If the ADST bit is set to 0 by a program, do not use the value of all the ADi register.

25.3.5 Low Current Consumption Function

When the A/D converter is not used, power consumption can be reduced by setting the ADSTBY bit in the ADCON1 register to 0 (A/D operation stops (standby)) to shut off any analog circuit current flow.

To use the A/D converter, set the ADSTBY bit to 1 (A/D operation enabled) and wait for 1 ϕ AD cycle or more before setting the ADST bit in the ADCON0 register to 1 (A/D conversion starts). Do not write 1 to bits ADST and ADSTBY at the same time.

Also, do not set the ADSTBY bit to 0 (A/D operation stops (standby)) during A/D conversion.

25.3.6 On-Chip Reference Voltage (OCVREF)

In one-shot mode, repeat mode 0, and repeat mode 1, the on-chip reference voltage (OCVREF) can be used as analog input.

Any variation in VREF can be confirmed using the on-chip reference voltage. Use the ADEX0 bit in the ADCON1 register and the OCVREFAN bit in the OCVREFCR register to select the on-chip reference voltage.

The A/D conversion result of the on-chip reference voltage in one-shot mode or in repeat mode 0 is stored in the AD0 register.

25.3.7 A/D Open-Circuit Detection Assist Function

To suppress influences of the analog input voltage leakage from the previously converted channel during A/D conversion operation, a function is incorporated to fix the electric charge on the chopper amp capacitor to the predetermined state (AVCC or GND) before starting conversion.

This function enables more reliable detection of an open circuit in the wiring connected to the analog input pins. Figure 25.5 shows the A/D Open-Circuit Detection Example on AVCC Side (Precharge before Conversion Selected) and Figure 25.6 shows the A/D Open-Circuit Detection Example on AVSS Side (Discharge before Conversion Selected).

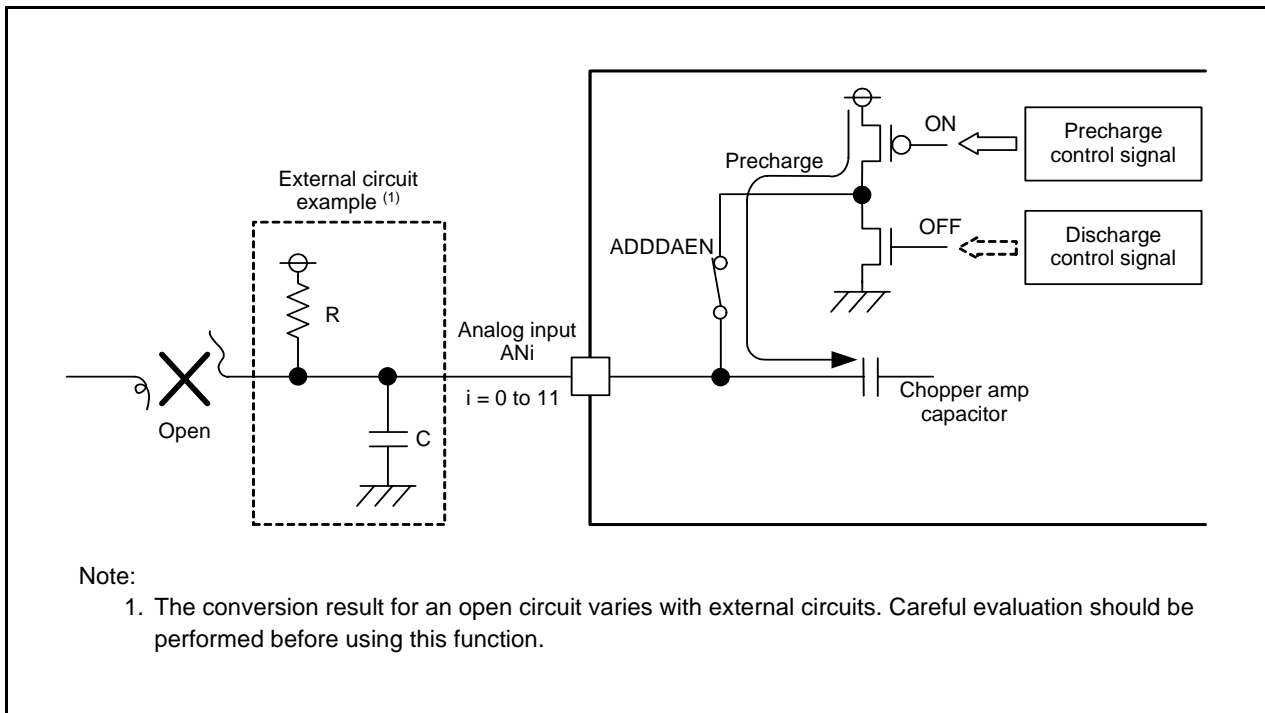

Figure 25.5 A/D Open-Circuit Detection Example on AVCC Side (Precharge before Conversion Selected)

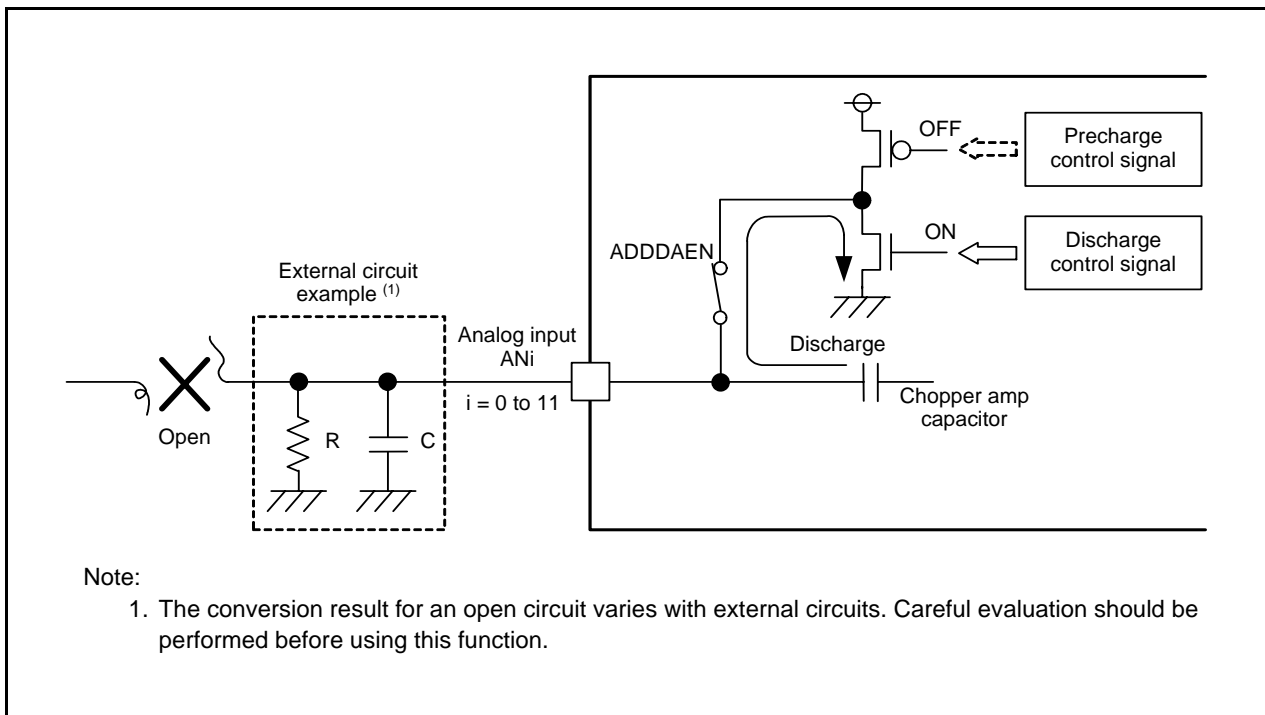

Figure 25.6 A/D Open-Circuit Detection Example on AVSS Side (Discharge before Conversion Selected)

25.4 One-Shot Mode

In one-shot mode, the input voltage to one pin selected from among AN0 to AN11 or OCVREF is A/D converted once.

Table 25.4 lists the One-Shot Mode Specifications.

Table 25.4 One-Shot Mode Specifications

Item	Specification
Function	The input voltage to the pin selected by bits CH2 to CH0 and bits ADGSEL1 to ADGSEL0 in the ADINSEL register or the ADEX0 bit in the ADCON1 register is A/D converted once.
Resolution	8 bits or 10 bits
A/D conversion start condition	<ul style="list-style-type: none"> • Software trigger • Timer RD • Timer RC • External trigger (Refer to 25.3.3 A/D Conversion Start Condition)
A/D conversion stop condition	<ul style="list-style-type: none"> • A/D conversion completes (If bits ADCAP1 to ADCAP0 in the ADMOD register are set to 00b (software trigger), the ADST bit in the ADCON0 register is set to 0.) • Set the ADST bit to 0
Interrupt request generation timing	When A/D conversion completes
Analog input pin	One pin selectable from among AN0 to AN11, or OCVREF.
Storage register for A/D conversion result	AD0 register: AN0, AN8, OCVREF AD1 register: AN1, AN9 AD2 register: AN2, AN10 AD3 register: AN3, AN11 AD4 register: AN4 AD5 register: AN5 AD6 register: AN6 AD7 register: AN7
Reading of result of A/D converter	Read register AD0 to AD7 corresponding to the selected pin.

25.5 Repeat Mode 0

In repeat mode 0, the input voltage to one pin selected from among AN0 to AN11 or OCVREF is A/D converted repeatedly.

Table 25.5 lists the Repeat Mode 0 Specifications.

Table 25.5 Repeat Mode 0 Specifications

Item	Specification
Function	The input voltage to the pin selected by bits CH2 to CH0 and bits ADGSEL1 to ADGSEL0 in the ADINSEL register or the ADEX0 bit in the ADCON1 register is A/D converted repeatedly.
Resolution	8 bits or 10 bits
A/D conversion start condition	<ul style="list-style-type: none"> • Software trigger • Timer RD • Timer RC • External trigger (Refer to 25.3.3 A/D Conversion Start Condition)
A/D conversion stop condition	Set the ADST bit in the ADCON0 register to 0
Interrupt request generation timing	Not generated
Analog input pin	One pin selectable from among AN0 to AN11, or OCVREF.
Storage register for A/D conversion result	AD0 register: AN0, AN8, OCVREF AD1 register: AN1, AN9 AD2 register: AN2, AN10 AD3 register: AN3, AN11 AD4 register: AN4 AD5 register: AN5 AD6 register: AN6 AD7 register: AN7
Reading of result of A/D converter	Read register AD0 to AD7 corresponding to the selected pin.

25.6 Repeat Mode 1

In repeat mode 1, the input voltage to one pin selected from among AN0 to AN11 or OCVREF is A/D converted repeatedly.

Table 25.6 lists the Repeat Mode 1 Specifications. Figure 25.7 shows the Operating Example of Repeat Mode 1.

Table 25.6 Repeat Mode 1 Specifications

Item	Specification
Function	The input voltage to the pin selected by bits CH2 to CH0 and bits ADGSEL1 to ADGSEL0 in the ADINSEL register or the ADEX0 bit in the ADCON1 register is A/D converted repeatedly.
Resolution	8 bits or 10 bits
A/D conversion start condition	<ul style="list-style-type: none"> • Software trigger • Timer RD • Timer RC • External trigger (Refer to 25.3.3 A/D Conversion Start Condition)
A/D conversion stop condition	Set the ADST bit in the ADCON0 register to 0
Interrupt request generation timing	When the A/D conversion result is stored in the AD7 register.
Analog input pin	One pin selectable from among AN0 to AN11, or OCVREF.
Storage register for A/D conversion result	AD0 register: 1st A/D conversion result, 9th A/D conversion result... AD1 register: 2nd A/D conversion result, 10th A/D conversion result... AD2 register: 3rd A/D conversion result, 11th A/D conversion result... AD3 register: 4th A/D conversion result, 12th A/D conversion result... AD4 register: 5th A/D conversion result, 13th A/D conversion result... AD5 register: 6th A/D conversion result, 14th A/D conversion result... AD6 register: 7th A/D conversion result, 15th A/D conversion result... AD7 register: 8th A/D conversion result, 16th A/D conversion result...
Reading of result of A/D converter	Read registers AD0 to AD7

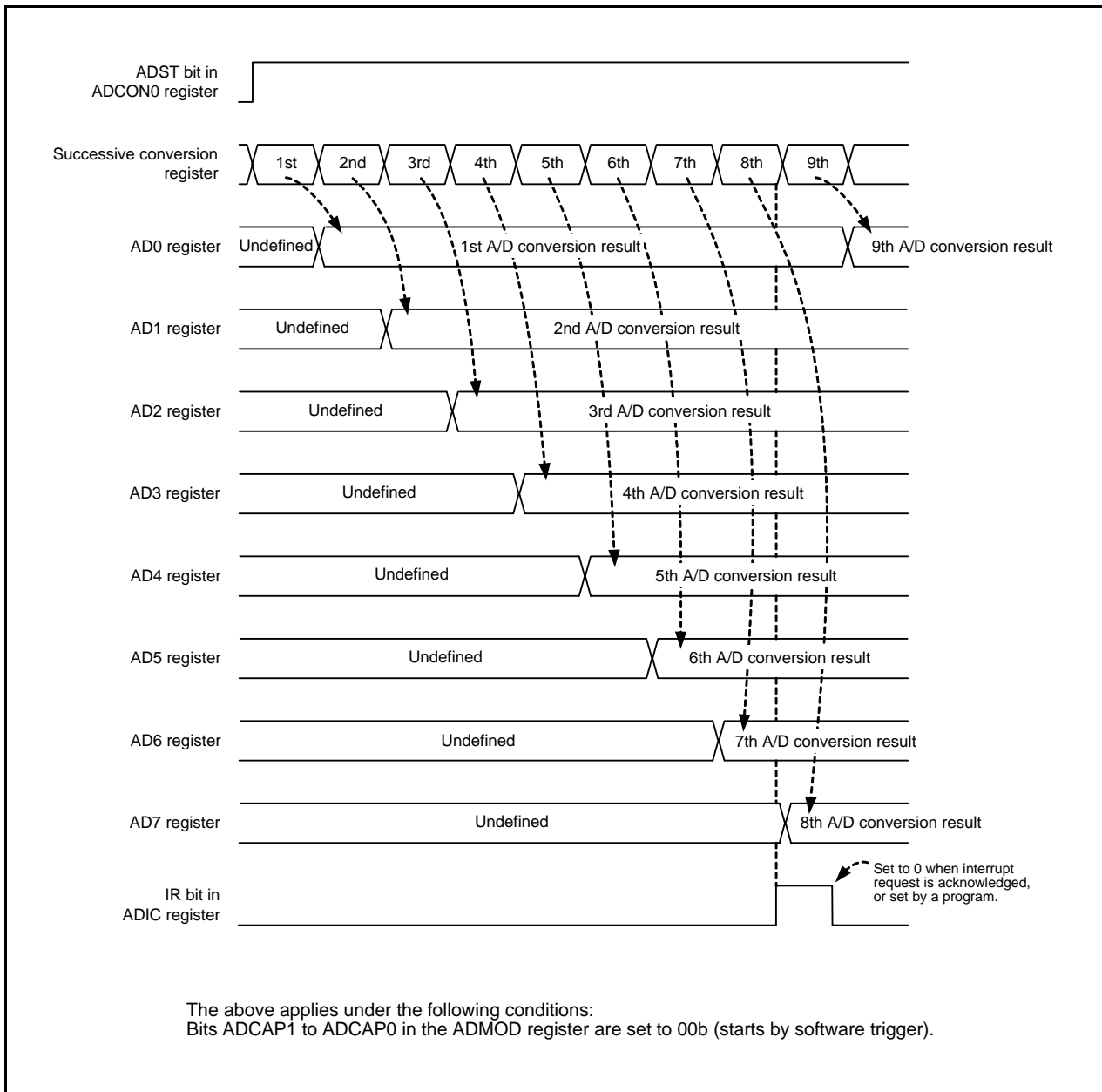

Figure 25.7 Operating Example of Repeat Mode 1

25.7 Single Sweep Mode

In single sweep mode, the input voltage to two, four, six, or eight pins selected from among AN0 to AN11 are A/D converted once.

Table 25.7 lists the Single Sweep Mode Specifications. Figure 25.8 shows the Operating Example of Single Sweep Mode.

Table 25.7 Single Sweep Mode Specifications

Item		Specification
Function		The input voltage to the pins selected by bits ADGSEL1 to ADGSEL0 and bits SCAN1 to SCAN0 in the ADINSEL register is A/D converted once.
Resolution		8 bits or 10 bits
A/D conversion start condition		<ul style="list-style-type: none"> • Software trigger • Timer RD • Timer RC • External trigger (Refer to 25.3.3 A/D Conversion Start Condition)
A/D conversion stop condition	Software trigger	<ul style="list-style-type: none"> • If two pins are selected, when A/D conversion of the two selected pins completes (the ADST bit in the ADCON0 register is set to 0). • If four pins are selected, when A/D conversion of the four selected pins completes (the ADST bit is set to 0). • If six pins are selected, when A/D conversion of the six selected pins completes (the ADST bit is set to 0). • If eight pins are selected, when A/D conversion of the eight selected pins completes (the ADST bit is set to 0). • Set the ADST bit to 0.
	Timer RD	Set the ADST bit to 0.
	Timer RC	
	External trigger	
Interrupt request generation timing		<ul style="list-style-type: none"> • If two pins are selected, when A/D conversion of the two selected pins completes. • If four pins are selected, when A/D conversion of the four selected pins completes. • If six pins are selected, when A/D conversion of the six selected pins completes. • If eight pins are selected, when A/D conversion of the eight selected pins completes.
Analog input pin		AN0 to AN1(2 pins), AN8 to AN9(2 pins), AN0 to AN3(4 pins), AN8 to AN11(4 pins), AN0 to AN5(6 pins), AN0 to AN7(8 pins) (Selectable by bits SCAN1 to SCAN0 and bits ADGSEL1 to ADGSEL0.)
Storage register for A/D conversion result		AD0 register: AN0, AN8 AD1 register: AN1, AN9 AD2 register: AN2, AN10 AD3 register: AN3, AN11 AD4 register: AN4 AD5 register: AN5 AD6 register: AN6 AD7 register: AN7
Reading of result of A/D converter		Read the registers from AD0 to AD7 corresponding to the selected pin.

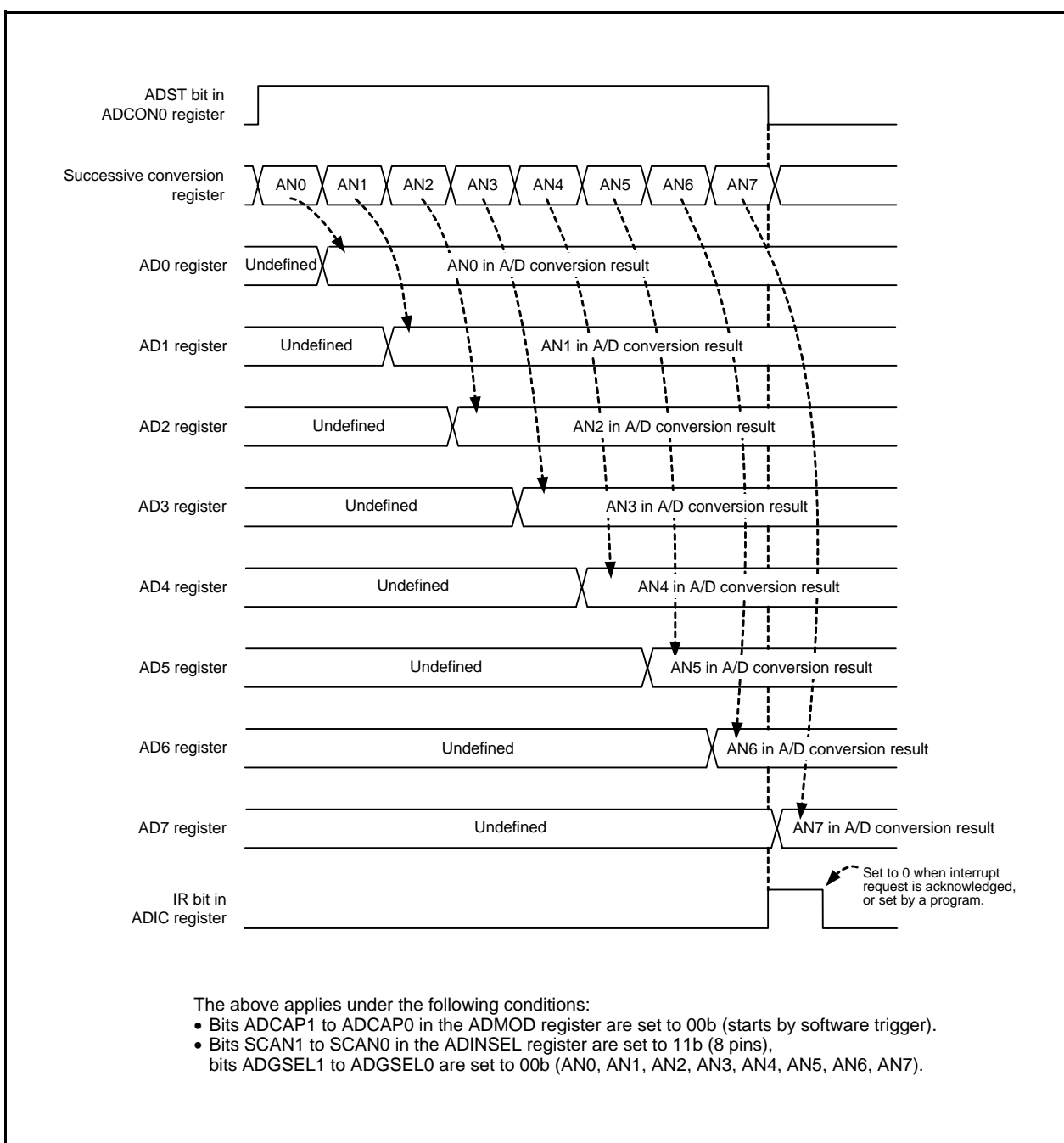

Figure 25.8 Operating Example of Single Sweep Mode

25.8 Repeat Sweep Mode

In repeat sweep mode, the input voltage to two, four, six, or eight pins selected from among AN0 to AN11 are A/D converted repeatedly.

Table 25.8 lists the Repeat Sweep Mode Specifications. Figure 25.9 shows the Operating Example of Repeat Sweep Mode.

Table 25.8 Repeat Sweep Mode Specifications

Item	Specification
Function	The input voltage to the pins selected by bits ADGSEL1 to ADGSEL0 and bits SCAN1 to SCAN0 in the ADINSEL register are A/D converted repeatedly.
Resolution	8 bits or 10 bits
A/D conversion start condition	<ul style="list-style-type: none"> • Software trigger • Timer RD • Timer RC • External trigger (Refer to 25.3.3 A/D Conversion Start Condition)
A/D conversion stop condition	Set the ADST bit in the ADCON0 register to 0
Interrupt request generation timing	<ul style="list-style-type: none"> • If two pins are selected, when A/D conversion of the two selected pins completes. • If four pins are selected, when A/D conversion of the four selected pins completes. • If six pins are selected, when A/D conversion of the six selected pins completes. • If eight pins are selected, when A/D conversion of the eight selected pins completes.
Analog input pin	AN0 to AN1(2 pins), AN8 to AN9(2 pins), AN0 to AN3(4 pins), AN8 to AN11(4 pins), AN0 to AN5(6 pins), AN0 to AN7(8 pins) (Selectable by bits SCAN1 to SCAN0 and bits ADGSEL1 to ADGSEL0.)
Storage register for A/D conversion result	AD0 register: AN0, AN8 AD1 register: AN1, AN9 AD2 register: AN2, AN10 AD3 register: AN3, AN11 AD4 register: AN4 AD5 register: AN5 AD6 register: AN6 AD7 register: AN7
Reading of result of A/D converter	Read the registers from AD0 to AD7 corresponding to the selected pin.

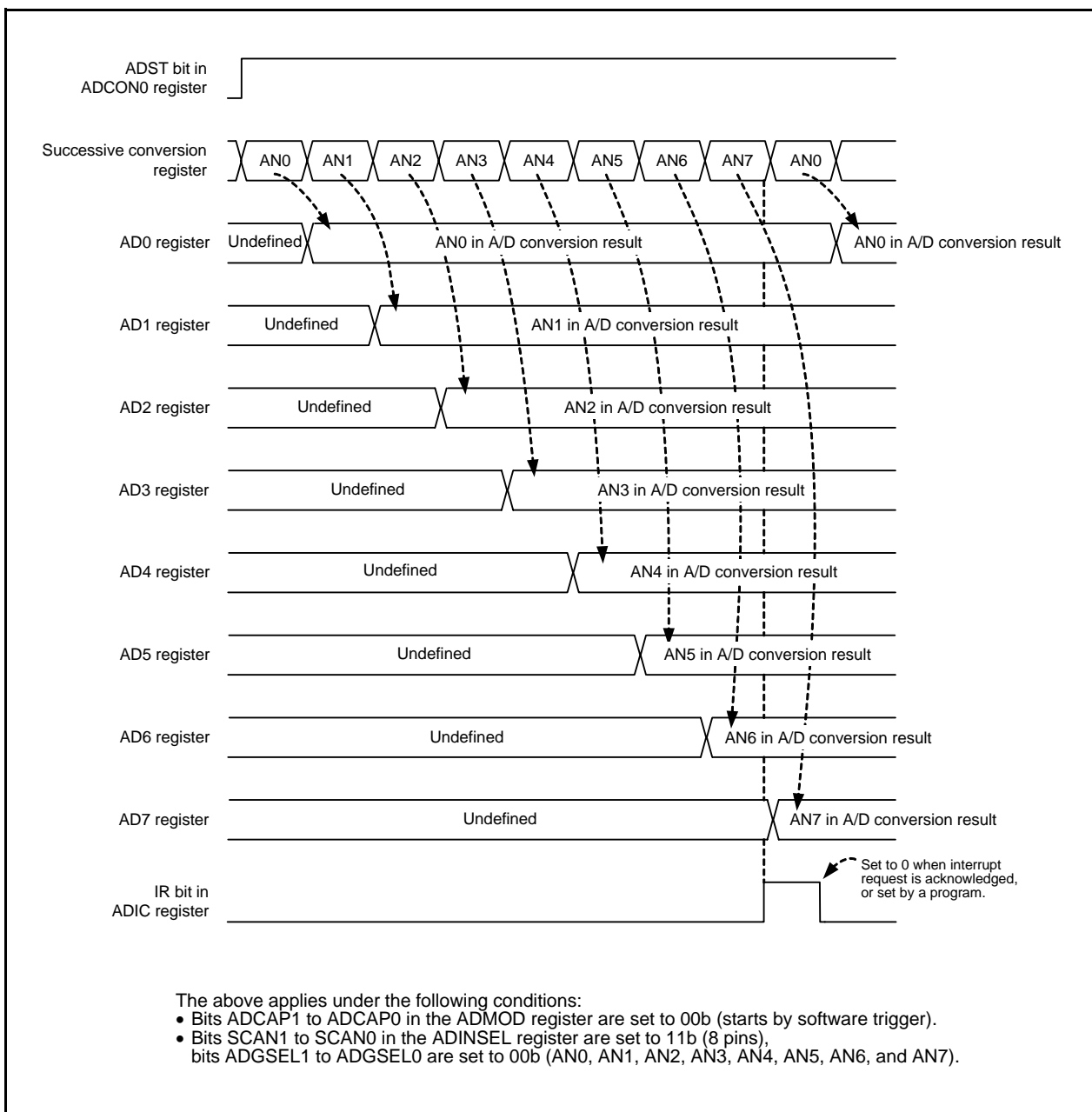

Figure 25.9 Operating Example of Repeat Sweep Mode

25.9 Output Impedance of Sensor under A/D Conversion

To carry out A/D conversion properly, charging the internal capacitor C shown in Figure 25.10 has to be completed within a specified period of time. T (sampling time) as the specified time. Let output impedance of sensor equivalent circuit be R0, internal resistance of microcomputer be R, precision (error) of the A/D converter be X, and the resolution of A/D converter be Y (Y is 1024 in the 10-bit mode, and 256 in the 8-bit mode).

$$VC \text{ is generally } VC = VIN \left\{ 1 - e^{-\frac{1}{C(R0+R)}t} \right\}$$

$$\text{And when } t = T, \quad VC = VIN - \frac{X}{Y} VIN = VIN \left(1 - \frac{X}{Y} \right)$$

$$e^{-\frac{1}{C(R0+R)}T} = \frac{X}{Y}$$

$$-\frac{1}{C(R0+R)}T = \ln \frac{X}{Y}$$

$$\text{Hence, } R0 = -\frac{T}{C \cdot \ln \frac{X}{Y}} - R$$

Figure 25.10 shows the Analog Input Pin and External Sensor Equivalent Circuit. When the difference between VIN and VC becomes 0.1LSB, we find impedance R0 when voltage between pins VC changes from 0 to VIN - (0.1/1024) VIN in time T. (0.1/1024) means that A/D precision drop due to insufficient capacitor charge is held to 0.1LSB at time of A/D conversion in the 10-bit mode. Actual error however is the value of absolute precision added to 0.1LSB.

T = 0.8 μs when φAD = 20 MHz. Output impedance R0 for sufficiently charging capacitor C within time T is determined as follows.

T = 0.8 μs, R = 10 kΩ, C = 6.0 pF, X = 0.1, and Y = 1024. Hence,

$$R0 = \frac{0.8 \times 10^{-6}}{6.0 \times 10^{-12} \cdot \ln \frac{0.1}{1024}} - 10 \times 10^3 \approx 4.4 \times 10^3$$

Thus, the allowable output impedance of the sensor equivalent circuit, making the precision (error) 0.1LSB or less, is approximately 4.4 kΩ maximum.

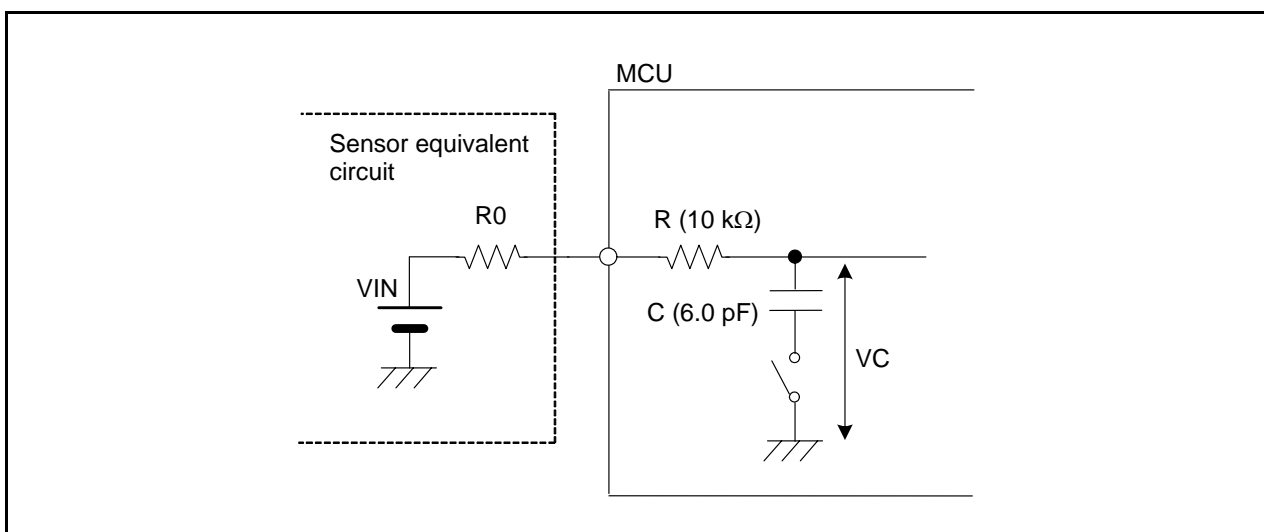

Figure 25.10 Analog Input Pin and External Sensor Equivalent Circuit

25.10 Notes on A/D Converter

- Write to the ADMOD register, the ADINSEL register, the ADCON0 register (other than ADST bit), the ADCON1 register, the OCVREFCR register when A/D conversion is stopped (before a trigger occurs).
- To use the A/D converter in repeat mode 0, repeat mode 1, or repeat sweep mode, select the frequency of the A/D converter operating clock ϕ_{AD} or more for the CPU clock during A/D conversion.
Do not select fOCO-F as ϕ_{AD} .
- Connect 0.1 μ F capacitor between the VREF pin and AVSS pin.
- Do not enter stop mode during A/D conversion.
- Do not enter wait mode during A/D conversion regardless of the state of the CM02 bit in the CM0 register (1: Peripheral function clock stops in wait mode or 0: Peripheral function clock does not stop in wait mode).
- Do not set the FMSTP bit in the FMR0 register to 1 (flash memory stops) or the FMR27 bit to 1 (low-current-consumption read mode enabled) during A/D conversion. Otherwise, the A/D conversion result will be undefined.
- Do not change the CKS2 bit in the ADMOD register while fOCO-F is stopped.
- During an A/D conversion operation, if the ADST bit in the ADCON0 register is set to 0 (A/D conversion stops) by a program to forcibly terminate A/D conversion, the conversion result of the A/D converter is undefined and no interrupt is generated. The value of the ADi register before A/D conversion may also be undefined. If the ADST bit is set to 0 by a program, do not use the value of all the ADi register.

26. D/A Converter

The D/A converters are 8-bit R-2R type units. There are two independent D/A converters.

26.1 Overview

D/A conversion is performed by writing a value to the DA_i register (i = 0 or 1). To output the conversion result, set the DA_iE bit in the DACON register to 1 (output enabled). Before using D/A conversion, set the corresponding bits PD0_6 and PD0_7 in the PD0 register to 0 (input mode) and the PU01 bit in the PUR0 register to 0 (not pulled up). The output analog voltage (V) is determined by the setting value n (n: decimal) of the DA_i register.

$$V = V_{ref} \times n / 256 \quad (n = 0 \text{ to } 255)$$

V_{ref}: Reference voltage

Table 26.1 lists the D/A Converter Specifications. Figure 26.1 shows the D/A Converter Block Diagram and Figure 26.2 shows the D/A Converter Equivalent Circuit.

Table 26.1 D/A Converter Specifications

Item	Performance
D/A conversion method	R-2R method
Resolution	8 bits
Analog output pins	2 (DA0 and DA1)

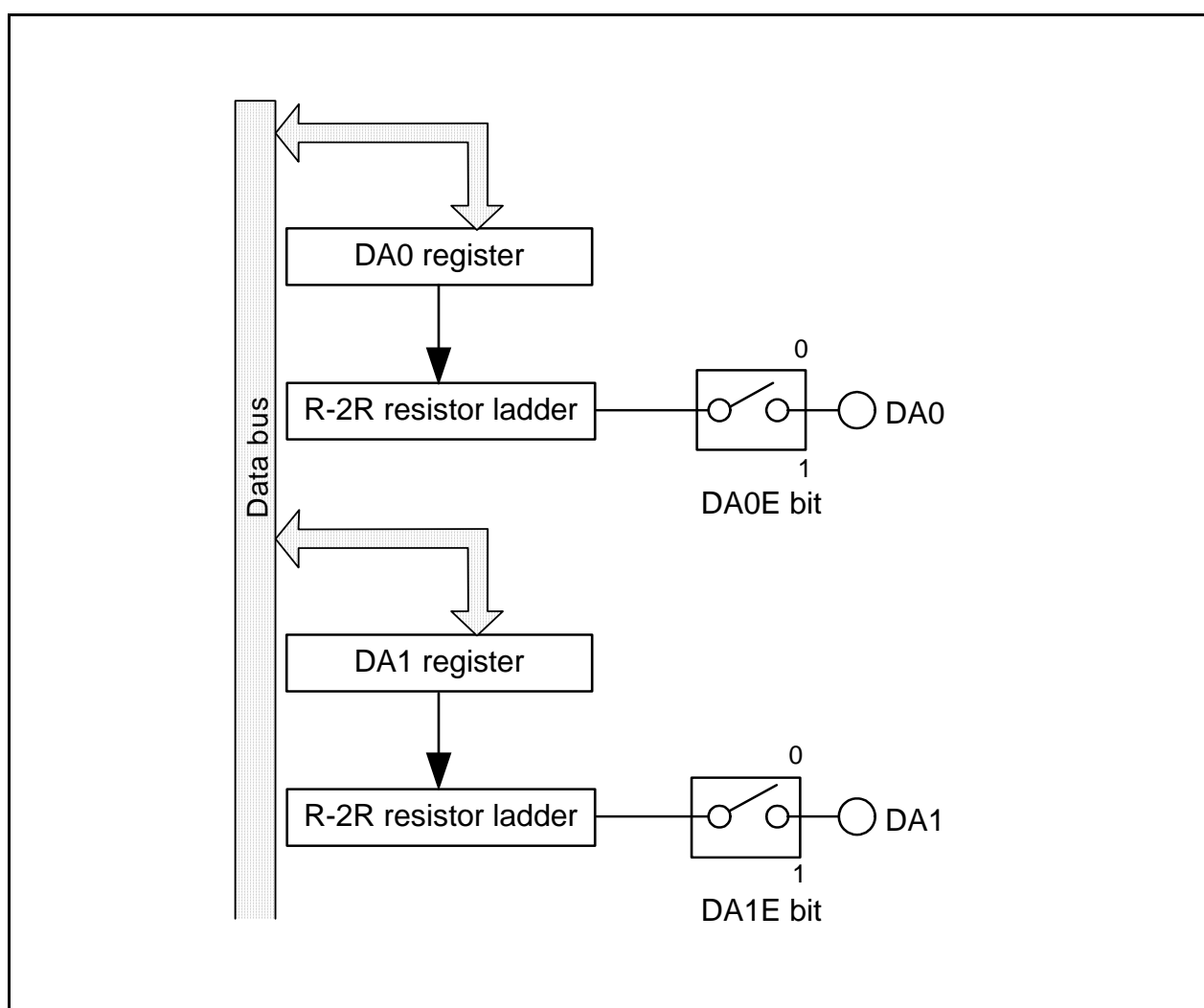

Figure 26.1 D/A Converter Block Diagram

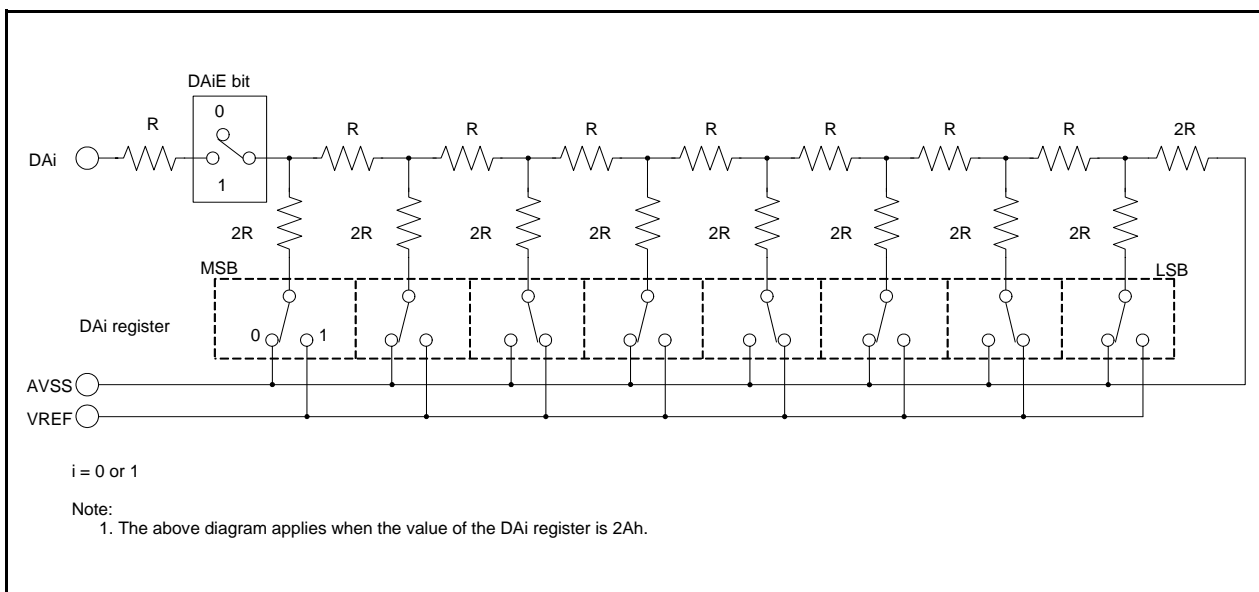

Figure 26.2 D/A Converter Equivalent Circuit

26.2 Registers

26.2.1 D/A_i Register (DA_i) (i = 0 or 1)

Address 00D8h (DA0), 00D9h (DA1)

Bit	b7	b6	b5	b4	b3	b2	b1	b0
Symbol	—	—	—	—	—	—	—	—
After Reset	0	0	0	0	0	0	0	0

Bit	Function	Setting Range	R/W
b7-b0	Output value of D/A conversion	00h to FFh	R/W

When the D/A converter is not used, set the DA_iE bit (i = 0 or 1) to 0 (output disabled) and set the DA_i register to 00h to prevent current from flowing into the R-2R resistor ladder to reduce unnecessary current consumption.

26.2.2 D/A Control Register (DACON)

Address 00DCh

Bit	b7	b6	b5	b4	b3	b2	b1	b0
Symbol	—	—	—	—	—	—	DA1E	DA0E
After Reset	0	0	0	0	0	0	0	0

Bit	Symbol	Bit Name	Function	R/W
b0	DA0E	D/A0 output enable bit	0: Output disabled 1: Output enabled	R/W
b1	DA1E	D/A1 output enable bit	0: Output disabled 1: Output enabled	R/W
b2	—	Nothing is assigned. If necessary, set to 0. When read, the content is 0.		—
b3	—			
b4	—			
b5	—			
b6	—			
b7	—			

When the D/A converter is not used, set the DA_iE bit (i = 0 or 1) to 0 (output disabled) and set the DA_i register to 00h to prevent current from flowing into the R-2R resistor ladder to reduce unnecessary current consumption.

27. Comparator B

Comparator B compares a reference input voltage and an analog input voltage. Comparator B1 and comparator B3 are independent of each other.

27.1 Overview

The comparison result of the reference input voltage and analog input voltage can be read by software. An input to the IVREF_i (i = 1 or 3) pin can be used as the reference input voltage.

Table 27.1 lists the Comparator B Specifications, Figure 27.1 shows a Comparator B Block Diagram, and Table 27.2 lists the I/O Pins.

Table 27.1 Comparator B Specifications

Item	Specification
Analog input voltage	Input voltage to the IVCMP _i pin
Reference input voltage	Input voltage to the IVREF _i pin
Comparison result	Read from the INT _i COUT bit in the INTCMP register
Interrupt request generation timing	When the comparison result changes.
Selectable functions	<ul style="list-style-type: none"> Digital filter function Whether the digital filter is applied or not and the sampling frequency can be selected.

i = 1 or 3

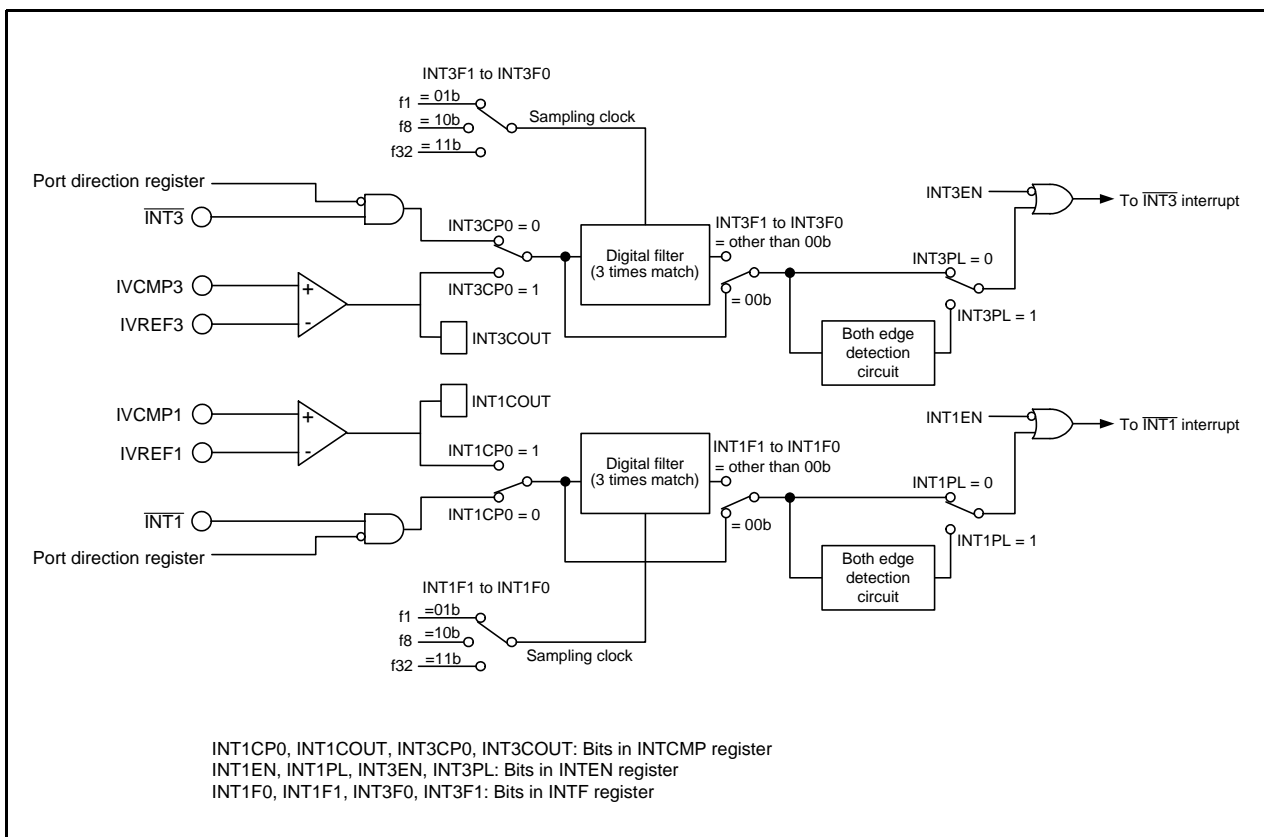

Figure 27.1 Comparator B Block Diagram

Table 27.2 I/O Pins

Pin Name	I/O	Function
IVCMP1	Input	Comparator B1 analog pin
IVREF1	Input	Comparator B1 reference voltage pin
IVCMP3	Input	Comparator B3 analog pin
IVREF3	Input	Comparator B3 reference voltage pin

27.2 Registers

27.2.1 Comparator B Control Register 0 (INTCMP)

Address 01F8h

Bit	b7	b6	b5	b4	b3	b2	b1	b0
Symbol	INT3COUT	—	—	INT3CP0	INT1COUT	—	—	INT1CP0
After Reset	0	0	0	0	0	0	0	0

Bit	Symbol	Bit Name	Function	R/W
b0	INT1CP0	Comparator B1 operation enable bit	0: Comparator B1 operation disabled 1: Comparator B1 operation enabled	R/W
b1	—	Reserved bits	Set to 0.	R/W
b2	—			
b3	INT1COUT	Comparator B1 monitor flag	0: IVCMP1 < IVREF1 or comparator B1 operation disabled 1: IVCMP1 > IVREF1	R
b4	INT3CP0	Comparator B3 operation enable bit	0: Comparator B3 operation disabled 1: Comparator B3 operation enabled	R/W
b5	—	Reserved bits	Set to 0.	R/W
b6	—			
b7	INT3COUT	Comparator B3 monitor flag	0: IVCMP3 < IVREF3 or comparator B3 operation disabled 1: IVCMP3 > IVREF3	R

27.2.2 External Input Enable Register 0 (INTEN)

Address 01FAh

Bit	b7	b6	b5	b4	b3	b2	b1	b0
Symbol	INT3PL	INT3EN	—	—	INT1PL	INT1EN	INT0PL	INT0EN
After Reset	0	0	0	0	0	0	0	0

Bit	Symbol	Bit Name	Function	R/W
b0	INT0EN	$\overline{\text{INT0}}$ input enable bit	0: Disabled 1: Enabled	R/W
b1	INT0PL	$\overline{\text{INT0}}$ input polarity select bit (1, 2)	0: One edge 1: Both edges	R/W
b2	INT1EN	$\overline{\text{INT1}}$ input enable bit	0: Disabled 1: Enabled	R/W
b3	INT1PL	$\overline{\text{INT1}}$ input polarity select bit (1, 2)	0: One edge 1: Both edges	R/W
b4	—	Reserved bits	Set to 0.	R/W
b5	—			
b6	INT3EN	$\overline{\text{INT3}}$ input enable bit	0: Disabled 1: Enabled	R/W
b7	INT3PL	$\overline{\text{INT3}}$ input polarity select bit (1, 2)	0: One edge 1: Both edges	R/W

Notes:

- To set the INTiPL bit (i = 0 to 1, 3) to 1 (both edges), set the POL bit in the INTiIC register to 0 (falling edge selected).
- The IR bit in the INTiIC register may be set to 1 (interrupt requested) if the INTEN register is rewritten. Refer to **11.8.4 Changing Interrupt Sources**.

27.2.3 INT Input Filter Select Register 0 (INTF)

Address 01FCh

Bit	b7	b6	b5	b4	b3	b2	b1	b0
Symbol	INT3F1	INT3F0	—	—	INT1F1	INT1F0	INT0F1	INT0F0
After Reset	0	0	0	0	0	0	0	0

Bit	Symbol	Bit Name	Function	R/W
b0	INT0F0	INT0 input filter select bit	^{b1 b0} 0 0: No filter 0 1: Filter with f1 sampling 1 0: Filter with f8 sampling 1 1: Filter with f32 sampling	R/W
b1	INT0F1			R/W
b2	INT1F0	INT1 input filter select bit	^{b3 b2} 0 0: No filter 0 1: Filter with f1 sampling 1 0: Filter with f8 sampling 1 1: Filter with f32 sampling	R/W
b3	INT1F1			R/W
b4	—	Reserved bits	Set to 0.	R/W
b5	—			R/W
b6	INT3F0	INT3 input filter select bit	^{b7 b6} 0 0: No filter 0 1: Filter with f1 sampling 1 0: Filter with f8 sampling 1 1: Filter with f32 sampling	R/W
b7	INT3F1			R/W

27.3 Functional Description

Comparator B1 and comparator B3 operate independently. Their operations are the same. Table 27.3 lists the Procedure for Setting Registers Associated with Comparator B.

Table 27.3 Procedure for Setting Registers Associated with Comparator B

Step	Register	Bit	Setting Value
1	Select the function of pins IVCMPi and IVREFi. Refer to 7.5 Port Settings . However, set registers and bits other than listed in step 2 and the following steps.		
2	INTF	Select whether to enable or disable the filter. Select the sampling clock.	
3	INTCMP	INTiCPO	1 (operation enabled)
4	Wait for comparator stability time (100 μ s max.)		
5	INTEN	INTiEN	When using an interrupt: 1 (interrupt enabled)
		INTiPL	When using an interrupt: Select the input polarity.
6	INTiIC	ILVL2 to ILVL0	When using an interrupt: Select the interrupt priority level.
		IR	When using an interrupt: 0 (no interrupt requested: initialization)

$i = 1$ or 3

Figure 27.2 shows an Operating Example of Comparator Bi ($i = 1$ or 3).

If the analog input voltage is higher than the reference input voltage, the INTiCOUT bit in the INTCMP register is set to 1. If the analog input voltage is lower than the reference input voltage, the INTiCOUT bit is set to 0. To use the comparator Bi interrupt, set the INTiEN bit in the INTEN register to 1 (interrupt enabled). If the comparison result changes at this time, a comparator Bi interrupt request is generated. Refer to **27.4 Comparator B1 and Comparator B3 Interrupts** for details of interrupts.

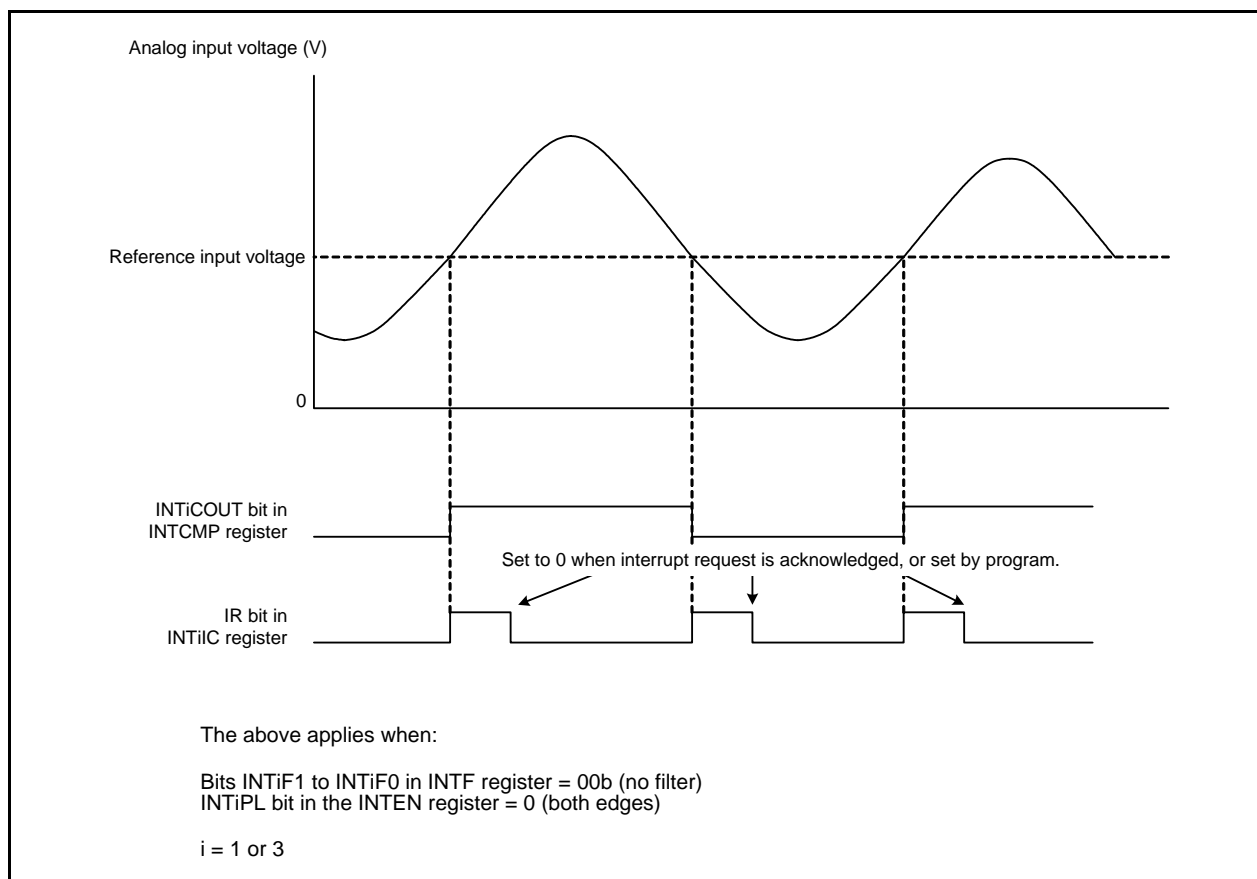

Figure 27.2 Operating Example of Comparator Bi ($i = 1$ or 3)

27.3.1 Comparator Bi Digital Filter (i = 1 or 3)

Comparator Bi can use the same digital filter as the $\overline{\text{INTi}}$ input. The sampling clock can be selected by bits INTiF1 and INTiF0 in the INTF register. The INTiCOUT signal output from comparator Bi is sampled every sampling clock. When the level matches three times, the IR bit in the INTiIC register is set to 1 (interrupt requested).

Figure 27.3 shows a Configuration of Comparator Bi Digital Filter, and Figure 27.4 shows an Operating Example of Comparator Bi Digital Filter.

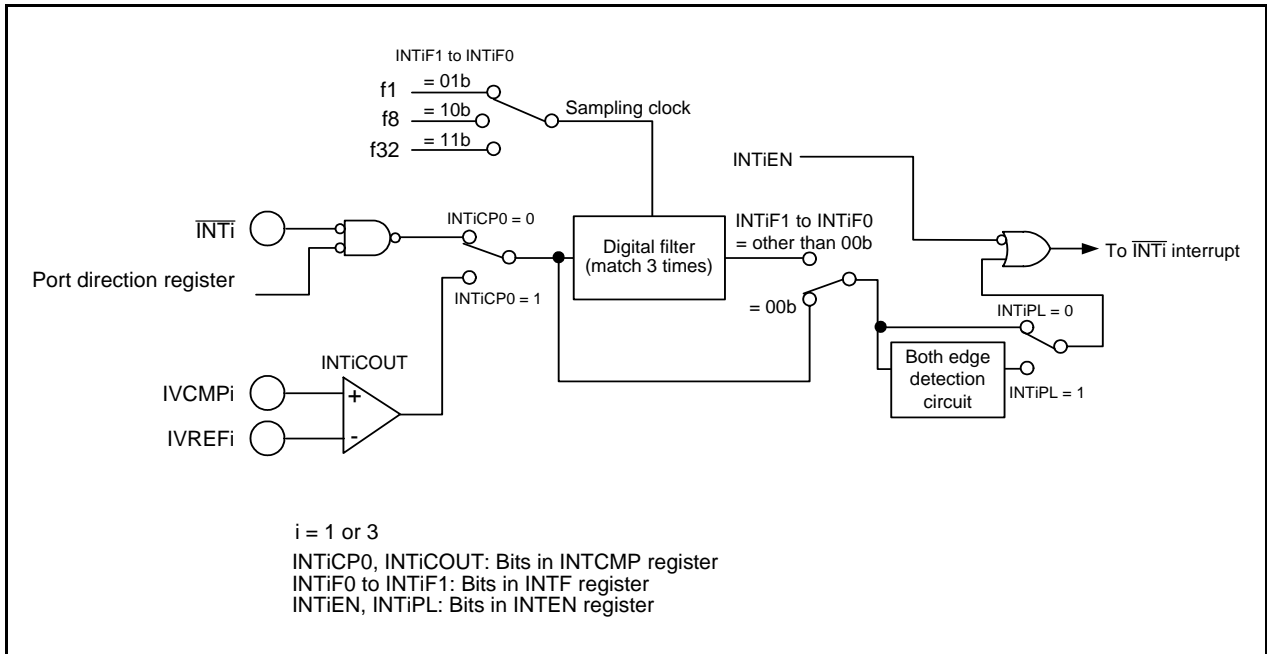

Figure 27.3 Configuration of Comparator Bi Digital Filter

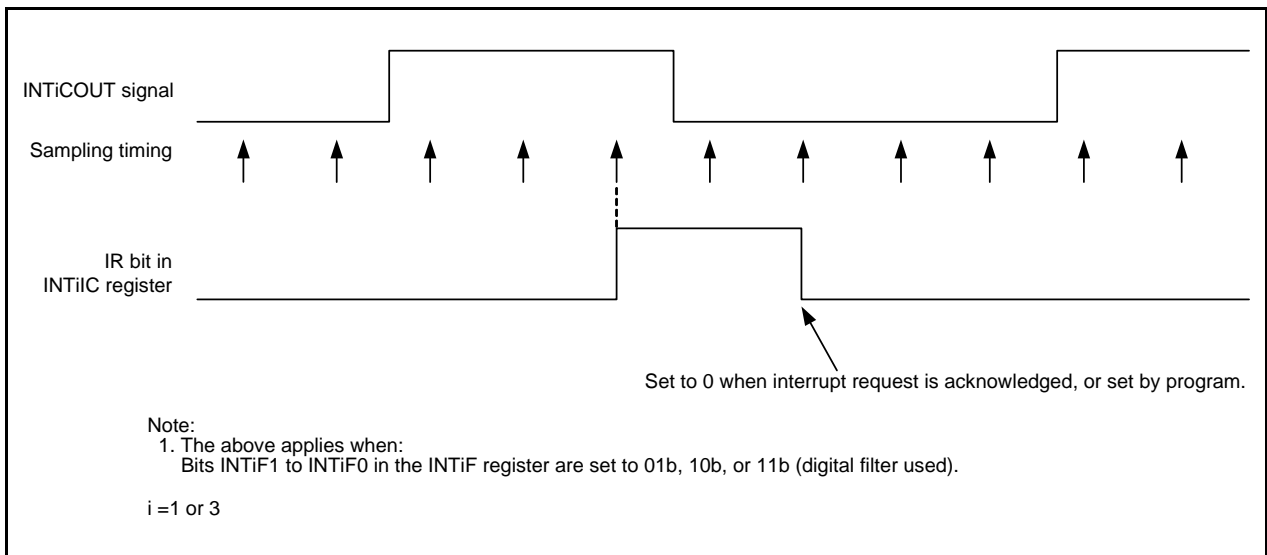

Figure 27.4 Operating Example of Comparator Bi Digital Filter

27.4 Comparator B1 and Comparator B3 Interrupts

Comparator B generates an interrupt request from two sources, comparator B1 and comparator B3. The comparator Bi (i = 1 or 3) interrupt uses the same INTiIC register (bits IR and ILVL0 to ILVL2) as the $\overline{\text{INTi}}$ (i = 1 or 3) and a single vector.

To use the comparator Bi interrupt, set the INTiEN bit in the INTEN register to 1 (interrupt enabled). In addition, the polarity can be selected by the INTiPL bit in the INTEN register and the POL bit in the INTiIC register. Inputs can also be passed through the digital filter with three different sampling clocks.

28. Flash Memory

The flash memory can perform in the following three rewrite modes: CPU rewrite mode, standard serial I/O mode, and parallel I/O mode.

28.1 Overview

Table 28.1 lists the Flash Memory Version Performance (R8C/33G Group) and Table 28.3 the Flash Memory Version Performance (R8C/33H Group) (Refer to **Table 1.1** and **Table 1.2 Specifications for R8C/33G Group** and **Table 1.3** and **Table 1.4 Specifications for R8C/33H Group**, for the items other than listed in **Table 28.1** and **Table 28.3**).

The R8C/33G Group has data flash (1 KB × 4 blocks) with the background operation (BGO) function.

Table 28.1 Flash Memory Version Performance (R8C/33G Group)

Item		Specification
Flash memory operating mode		3 modes (CPU rewrite, standard serial I/O, and parallel I/O)
Division of erase blocks		Refer to Figure 28.1 .
Programming method		Byte units
Erasure method		Block erase
Programming and erasure control method (1)		Program and erase control by software commands
Rewrite control method	Blocks 0 to 3 (Program ROM) (3)	Rewrite protect control in block units by the lock bit
	Blocks A, B, C, and D (Data flash)	Individual rewrite protect control on blocks A, B, C, and D by bits FMR14, FMR15, FMR16, and FMR17 in the FMR1 register
Number of commands		7 commands
Programming and erasure endurance (2)	Blocks 0 to 3 (Program ROM) (3)	1,000 times
	Blocks A, B, C, and D (Data flash)	10,000 times
ID code check function		Standard serial I/O mode supported
ROM code protection		Parallel I/O mode supported

Notes:

1. To perform programming and erasure, use VCC = 2.7 V to 5.5 V as the supply voltage. Do not perform programming and erasure at less than 2.7 V.
2. Definition of programming and erasure endurance
The programming and erasure endurance is defined on a per-block basis. If the programming and erasure endurance is n (n = 1,000 or 10,000), each block can be erased n times. For example, if 1,024 1-byte writes are performed to different addresses in block A, a 1-Kbyte block, and then the block is erased, the programming/erasure endurance still stands at one. When performing 100 or more rewrites, the actual erase count can be reduced by executing program operations in such a way that all blank areas are used before performing an erase operation. Avoid rewriting only particular blocks and try to average out the programming and erasure endurance of the blocks. It is also advisable to retain data on the erasure endurance of each block and limit the number of erase operations to a certain number.
3. The number of blocks and block division vary with the MCU. Refer to **Figure 28.1 R8C/33G Group, R8C/33H Group Flash Memory Block Diagram** for details.

Table 28.2 Flash Memory Version Performance (R8C/33H Group)

Item		Specification
Flash memory operating mode		3 modes (CPU rewrite, standard serial I/O, and parallel I/O)
Division of erase blocks		Refer to Figure 28.1 .
Programming method		Byte units
Erasure method		Block erase
Programming and erasure control method		Program and erase control by software commands
Rewrite control method	Blocks 0 to 3 (Program ROM) ⁽³⁾	Rewrite protect control in block units by the lock bit
Number of commands		7 commands
Programming and erasure endurance ⁽²⁾	Blocks 0 to 3 (Program ROM) ⁽³⁾	100 times
ID code check function		Standard serial I/O mode supported
ROM code protection		Parallel I/O mode supported

Notes:

- Definition of programming and erasure endurance
The programming and erasure endurance is defined on a per-block basis. If the programming and erasure endurance is 100, each block can be erased 100 times. For example, if 4,096 1-byte writes are performed to different addresses in block, a 4-Kbyte block, and then the block is erased, the programming/erasure endurance still stands at one. The actual erase count can be reduced by executing program operations in such a way that all blank areas are used before performing an erase operation. Avoid rewriting only particular blocks and try to average out the programming and erasure endurance of the blocks. It is also advisable to retain data on the erasure endurance of each block and limit the number of erase operations to a certain number.
- The number of blocks and block division vary with the MCU. Refer to **Figure 28.1 R8C/33G Group, R8C/33H Group Flash Memory Block Diagram** for details.

Table 28.3 Flash Memory Rewrite Mode

Flash Memory Rewrite Mode	CPU Rewrite Mode	Standard Serial I/O Mode	Parallel I/O Mode
Function	User ROM area is rewritten by executing software commands from the CPU.	User ROM area is rewritten using a dedicated serial programmer.	User ROM area is rewritten using a dedicated parallel programmer.
Rewritable area	User ROM	User ROM	User ROM
Rewrite programs	User program	Standard boot program	–

28.2 Memory Map

The flash memory contains a user ROM area and a boot ROM area (reserved area).

Figure 28.1 show the R8C/33G Group, R8C/33H Group Flash Memory Block Diagram.

The user ROM area contains program ROM and data flash (only for the R8C/33G Group).

Program ROM: Flash memory mainly used for storing programs

Data flash: Flash memory mainly used for storing data to be rewritten

The user ROM area is divided into several blocks. The user ROM area can be rewritten in CPU rewrite mode, standard serial I/O mode, or parallel I/O mode.

The rewrite control program (standard boot program) for standard serial I/O mode is stored in the boot ROM area before shipment. The boot ROM area is allocated separately from the user ROM area.

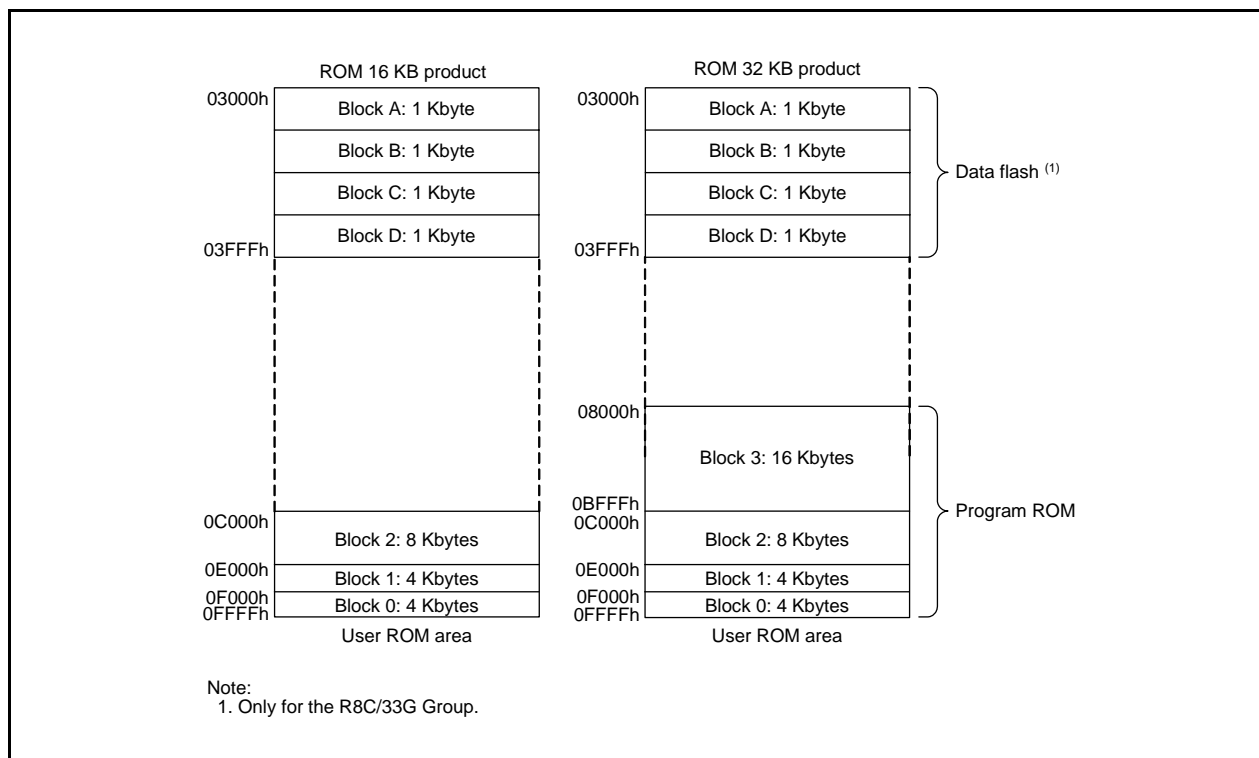

Figure 28.1 R8C/33G Group, R8C/33H Group Flash Memory Block Diagram

28.3 Functions to Prevent Flash Memory from being Rewritten

Standard serial I/O mode has an ID code check function, and parallel I/O mode has a ROM code protect function to prevent the flash memory from being read or rewritten easily.

28.3.1 ID Code Check Function

The ID code check function is used in standard serial I/O mode. Unless 3 bytes (addresses 0FFFCh to 0FFFEh) of the reset vector are set to FFFFFFFh, the ID codes sent from the serial programmer or the on-chip debugging emulator and the 7-byte ID codes written in the flash memory are checked to see if they match. If the ID codes do not match, the commands sent from the serial programmer or the on-chip debugging emulator are not accepted. For details of the ID code check function, refer to **12. ID Code Areas**.

28.3.2 ROM Code Protect Function

The ROM protect function prevents the contents of the flash memory from being read, rewritten, or erased using the OFS register in parallel I/O mode.

Refer to **13. Option Function Select Area** for details of the option function select area.

The ROM code protect function is enabled by writing 1 to the ROMCR bit and writing 0 to the ROMCP1 bit. This prevents the contents of the on-chip flash memory from being read or rewritten.

Once ROM code protection is enabled, the content of the internal flash memory cannot be rewritten in parallel I/O mode. To disable ROM code protection, erase the block including the OFS register using CPU rewrite mode or standard serial I/O mode.

28.3.3 Option Function Select Register (OFS)

Address 0FFFFh								
Bit	b7	b6	b5	b4	b3	b2	b1	b0
Symbol	CSPROINI	LVDAS	—	—	ROMCP1	ROMCR	—	WDTON
After Reset	User Setting Value ⁽¹⁾							

Bit	Symbol	Bit Name	Function	R/W
b0	WDTON	Watchdog timer start select bit	0: Watchdog timer automatically starts after reset 1: Watchdog timer is stopped after reset	R/W
b1	—	Reserved bit	Set to 1.	R/W
b2	ROMCR	ROM code protect disable bit	0: ROM code protect disabled 1: ROMCP1 bit enabled	R/W
b3	ROMCP1	ROM code protect bit	0: ROM code protect enabled 1: ROM code protect disabled	R/W
b4	—	Reserved bit	Set to 1.	R/W
b5	—	Reserved bit	Set to 0.	R/W
b6	LVDAS	Voltage detection 0 circuit start bit ⁽²⁾	0: Voltage monitor 0 reset enabled after reset 1: Voltage monitor 0 reset disabled after reset	R/W
b7	CSPROINI	Count source protection mode after reset select bit	0: Count source protect mode enabled after reset 1: Count source protect mode disabled after reset	R/W

Notes:

- The OFS register is allocated in the flash memory, not in the SFRs. Set appropriate values as ROM data by a program.
Do not write additions to the OFS register. If the block including the OFS register is erased, the OFS register is set to FFh.
When blank products are shipped, the OFS register is set to FFh. It is set to the written value after written by the user.
When factory-programming products are shipped, the value of the OFS register is the value programmed by the user.
- To use power-on reset and voltage monitor 0 reset, set the LVDAS bit to 0 (voltage monitor 0 reset enabled after reset).

For a setting example of the OFS register, refer to **13.3.1 Setting Example of Option Function Select Area**.

28.4 CPU Rewrite Mode

In CPU rewrite mode, the user ROM area can be rewritten by executing software commands from the CPU. Therefore, the user ROM area can be rewritten directly while the MCU is mounted on a board without using a ROM programmer. Execute the software command only to blocks in the user ROM area.

The flash module has an erase-suspend function which halts the erase operation temporarily during an erase operation in CPU rewrite mode. During erase-suspend, the flash memory can be read or programmed.

Erase-write 0 mode (EW0 mode) and erase-write 1 mode (EW1 mode) are available in CPU rewrite mode.

Table 28.4 lists the Differences between EW0 Mode and EW1 Mode.

Table 28.4 Differences between EW0 Mode and EW1 Mode

Item	EW0 Mode	EW1 Mode
Operating mode	Single-chip mode	Single-chip mode
Rewrite control program allocatable area	User ROM	User ROM
Rewrite control program executable areas ⁽¹⁾	RAM (The rewrite control program must be transferred before being executed.) However, the program can be executed in the program ROM area when rewriting the data flash area.	User ROM or RAM
Rewritable area	User ROM	User ROM However, blocks which contain the rewrite control program are excluded.
Software command restrictions ⁽¹⁾	—	Program and block erase commands Cannot be executed to any block which contains the rewrite control program.
Mode after programming or block erasure or after entering erase-suspend	Read array mode	Read array mode
CPU and DTC state during programming and block erasure ⁽¹⁾	The CPU operates.	<ul style="list-style-type: none"> The CPU or DTC operates while the data flash area is being programmed or block erased. The CPU or DTC is put in a hold state while the program ROM area is being programmed or block erased. (I/O ports retain the state before the command execution).
Flash memory status detection	Read bits FST7, FMT5, and FMT4 in the FST register by a program.	Read bits FST7, FST5, and FST4 in the FST register by a program.
Conditions for entering erase-suspend ⁽¹⁾	<ul style="list-style-type: none"> Set bits FMR20 and FMR21 in the FMR2 register to 1 by a program. Set bits FMR20 and FMR22 in the FMR2 register to 1 and the enabled maskable interrupt is generated. 	<ul style="list-style-type: none"> Set bits FMR20 and FMR21 in the FMR2 register to 1 by a program (while rewriting the data flash area). Set bits FMR20 and FMR22 in the FMR2 register to 1 and the enabled maskable interrupt is generated.
CPU clock	Max. 20 MHz	Max. 20 MHz

Note:

1. The R8C/33G Group has data flash.

28.4.1 Flash Memory Status Register (FST)

Address 01B2h

Bit	b7	b6	b5	b4	b3	b2	b1	b0
Symbol	FST7	FST6	FST5	FST4	—	LBDATA	BSYAEI	RDYSTI
After Reset	1	0	0	0	0	X	0	0

Bit	Symbol	Bit Name	Function	R/W
b0	RDYSTI	Flash ready status interrupt request flag (1, 4)	0: No flash ready status interrupt request 1: Flash ready status interrupt request	R/W
b1	BSYAEI	Flash access error interrupt request flag (2, 4)	0: No flash access error interrupt request 1: Flash access error interrupt request	R/W
b2	LBDATA	LBDATA monitor flag	0: Locked 1: Not locked	R
b3	—	Nothing is assigned. If necessary, set to 0. When read, the content is 0.		—
b4	FST4	Program error flag (3)	0: No program error 1: Program error	R
b5	FST5	Erase error flag (3)	0: No erase error 1: Erase error	R
b6	FST6	Erase-suspend status flag	0: Other than erase-suspend 1: During erase-suspend	R
b7	FST7	Ready/busy status flag	0: Busy 1: Ready	R

Notes:

- The RDYSTI bit cannot be set to 1 (flash ready status interrupt request) by a program.
When writing 0 (no flash ready status interrupt request) to the RDYSTI bit, read this bit (dummy read) before writing to it.
Make sure the DTC is not activated by the flash ready status source between reading and writing.
To confirm this bit, set the RDYSTIE bit in the FMR0 register to 1 (flash ready status interrupt enabled).
- The BSYAEI bit cannot be set to 1 (flash access error interrupt request) by a program.
When writing 0 (no flash access error interrupt request) to the BSYAEI bit, read this bit (dummy read) before writing to it.
To confirm this bit, set the BSYAEIE bit in the FMR0 register to 1 (flash access error interrupt enabled) or set the CMDERIE bit in the FMR0 register to 1 (erase/write error interrupt enabled).
- This bit is also set to 1 (error) when a command error occurs.
- When this bit is set to 1, do not set the FMR01 bit in the FMR0 register to 0 (CPU rewrite mode disabled).

RDYSTI Bit (Flash Ready Status Flag Interrupt Request Flag)

When the RDYSTIE bit in the FMR0 register is set to 1 (flash ready status interrupt enabled) and auto-programming or auto-erasure completes, or erase-suspend mode is entered, the RDYSTI bit is set to 1 (flash ready status interrupt request).

During interrupt handling, set the RDYSTI bit to 0 (no flash ready status interrupt request).

[Condition for setting to 0]

Set to 0 by an interrupt handling program.

[Condition for setting to 1]

When the flash memory status changes from busy to ready while the RDYSTIE bit in the FRMR0 register is set to 1, the RDYSTI bit is set to 1.

The status is changed from busy to ready in the following states:

- Completion of erasing/programming the flash memory
- Suspend acknowledgement
- Completion of forcible termination
- Completion of the lock bit program
- Completion of the read lock bit status
- When the flash memory can be read after it has been stopped.

BSYAEI Bit (Flash Access Error Interrupt Request Flag)

The BSYAEI bit is set to 1 (flash access error interrupt request) when the BSYAEIE bit in the FMR0 register is set to 1 (flash access error interrupt enabled) and the block during auto-programming/auto-erasure is accessed. This bit is also set to 1 if an erase or program error occurs when the CMDERIE bit in the FMR0 register is set to 1 (erase/write error interrupt enabled).

During interrupt handling, set the BSYAEI bit to 0 (no flash access error interrupt request).

[Conditions for setting to 0]

- (1) Set to 0 by an interrupt handling program.
- (2) Execute the clear status register command.

[Conditions for setting to 1]

- (1) Read or write the area that is being erased/written when the BSYAEIE bit in the FMR0 register is set to 1 and while the flash memory is busy.
Or, read the data flash area (only for the R8C/33G Group) while erasing/writing to the program ROM area. (Note that the read value is undefined in both cases. Writing has no effect.)
- (2) If a command sequence error, erase error, or program error occurs when the CMDERIE bit in the FMR0 register is set to 1 (erase/write error interrupt enabled).

LBDATA Bit (LBDATA Monitor Flag)

This is a read-only bit indicating the lock bit status. To confirm the lock bit status, execute the read lock bit status command and read the LBDATA bit after the FST7 bit is set to 1 (ready).

The condition for updating this bit is when the program, erase, read lock bit status commands are generated.

When the read lock bit status command is input, the FST7 bit is set to 0 (busy). At the time when the FST7 bit is set to 1 (ready), the lock bit status is stored in the LBDATA bit. The data in the LBDATA bit is retained until the next command is input.

FST4 Bit (Program Error Flag)

This is a read-only bit indicating the auto-programming status. The bit is set to 1 if a program error occurs; otherwise, it is set to 0. For details, refer to the description in **28.4.14 Full Status Check**.

FST5 Bit (Erase Error Flag)

This is a read-only bit indicating the status of auto-erasure command. The bit is set to 1 if an erase error occurs; otherwise, it is set to 0. Refer to **28.4.14 Full Status Check** for details.

FST6 Bit (Erase Suspend Status Flag)

This is a read-only bit indicating the suspend status. The bit is set to 1 when an erase-suspend request is acknowledged and a suspend status is entered; otherwise, it is set to 0.

FST7 Bit (Ready/Busy Status Flag)

When the FST7 bit is set to 0 (busy), the flash memory is in one of the following states:

- During programming
- During erasure
- During the lock bit program
- During the read lock bit status
- During forced stop operation
- The flash memory is being stopped
- The flash memory is being activated

Otherwise, the FST7 bit is set to 1 (ready).

28.4.2 Flash Memory Control Register 0 (FMR0)

Address 01B4h

Bit	b7	b6	b5	b4	b3	b2	b1	b0
Symbol	RDYSTIE	BSYAEIE	CMDERIE	CMDRST	FMSTP	FMR02	FMR01	—
After Reset	0	0	0	0	0	0	0	0

Bit	Symbol	Bit Name	Function	R/W
b0	—	Reserved bit	Set to 0.	R/W
b1	FMR01	CPU rewrite mode select bit (1, 4)	0: CPU rewrite mode disabled 1: CPU rewrite mode enabled	R/W
b2	FMR02	EW1 mode select bit (1)	0: EW0 mode 1: EW1 mode	R/W
b3	FMSTP	Flash memory stop bit (2)	0: Flash memory operates 1: Flash memory stops (Low-power consumption state, flash memory initialization)	R/W
b4	CMDRST	Erase/write sequence reset bit (3)	When the CMDRST bit is set to 1, the erase/write sequence is reset and erasure/writing can be forcibly stopped. When read, the content is 0.	R/W
b5	CMDERIE	Erase/write error interrupt enable bit	0: Erase/write error interrupt disabled 1: Erase/write error interrupt enabled	R/W
b6	BSYAEIE	Flash access error interrupt enable bit	0: Flash access error interrupt disabled 1: Flash access error interrupt enabled	R/W
b7	RDYSTIE	Flash ready status interrupt enable bit	0: Flash ready status interrupt disabled 1: Flash ready status interrupt enabled	R/W

Notes:

1. To set this bit to 1, first write 0 and then 1 immediately. Disable interrupts and DTC activation between writing 0 and writing 1.
2. Write to the FMSTP bit by a program transferred to the RAM. The FMSTP bit is enabled when the FMR01 bit is set to 1 (CPU rewrite mode enabled). To set the FMSTP bit to 1 (flash memory stops), set it when the FST7 bit in the FST register is set to 1 (ready).
3. The CMDRST bit is enabled when the FMR01 bit is set to 1 (CPU rewrite mode enabled) and the FST7 bit in the FST register is set to 0 (busy).
4. To set the FMR01 bit to 0 (CPU rewrite mode disabled), set it when the RDYSTI bit in the FST register is set to 0 (no flash ready status interrupt request) and the BSYAEI bit is set to 0 (no flash access error interrupt request).

FMR01 Bit (CPU Rewrite Mode Select Bit)

When the FMR01 bit is set to 1 (CPU rewrite mode enabled), the MCU is made ready to accept software commands.

FMR02 Bit (EW1 Mode Select Bit)

When the FMR02 bit is set to 1 (EW1 mode), EW1 mode is selected.

FMSTP Bit (Flash Memory Stop Bit)

This bit is used to initialize the flash memory control circuits, and also to reduce the amount of current consumed by the flash memory. Access to the flash memory is disabled by setting the FMSTP bit to 1.

Write to the FMSTP bit by a program transferred to the RAM.

To reduce the power consumption further in high-speed on-chip oscillator mode, low-speed on-chip oscillator mode (XIN clock stopped), set the FMSTP bit to 1. Refer to **29.2.10 Stopping Flash Memory** for details.

When entering stop mode or wait mode while CPU rewrite mode is disabled, the FMR0 register does not need to be set because the power for the flash memory is automatically turned off and is turned back on when exiting stop or wait mode.

When the FMSTP bit is set to 1 (including during the busy status (the period while the FST7 bit is 0) immediately after the FMSTP bit is changed from 1 to 0), do not set to low-current-consumption read mode at the same time.

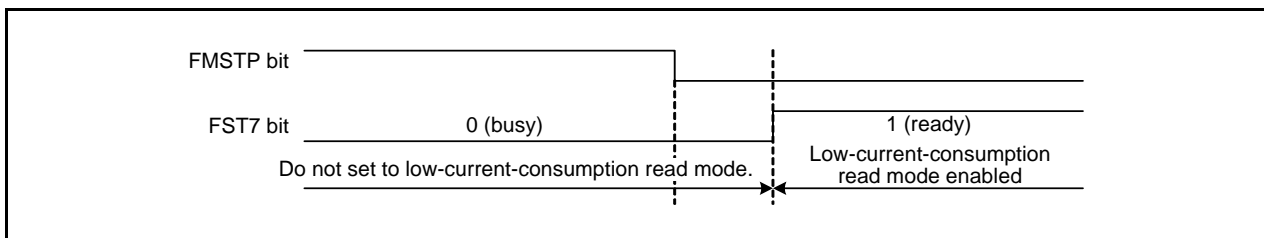

Figure 28.2 Transition to Low-Current-Consumption Read Mode

CMDRST Bit (Erase/Write Sequence Reset Bit)

This bit is used to initialize the flash memory sequence and forcibly stop a program or block erase command. The program ROM area can be read when resetting the sequence of programming/erasing the data flash area (only for the R8C/33G Group).

If the program or block erase command is forcibly stopped using the CMDRST bit in the FMR0 register, execute the clear status command after the FST7 bit in the FST register is changed to 1 (ready). To program to the same address again, execute the block erase command again and ensure it has been completed normally before programming. If the addresses and blocks which the program or block erase command is forcibly stopped are allocated in the program area, set the FMR13 bit in the FMR1 register to 1 (lock bit disabled) before executing the block erase command again.

When the CMDRST bit is set to 1 (erasure/writing stopped) during erase-suspend, the suspend status is also initialized. Thus execute block erasure again to the block which the block erasure is being suspended.

When $t_d(\text{CMDRST-READY})$ has elapsed after the CMDRST bit is set to 1 (erasure/writing stopped), the executing command is forcibly terminated and reading from the flash memory is enabled.

CMDERIE Bit (Erase/Write Error Interrupt Enable Bit)

This bit enables an flash command error interrupt to be generated if the following errors occur:

- Program error
- Block erase error
- Command sequence error

If the CMDERIE bit is set to 1 (erase/write error interrupt enabled), an interrupt is generated if the above errors occur.

If a flash command error interrupt is generated, execute the clear status register command during interrupt handling.

To change the CMDERIE bit from 0 (erase/write error interrupt disabled) to 1 (erase/write error interrupt enabled), make the setting as follows:

- (1) Execute the clear status register command.
- (2) Set the CMDERIE bit to 1.

BSYAEIE Bit (Flash Access Error Interrupt Enable Bit)

This bit enables a flash access error interrupt to be generated if the flash memory during rewriting is accessed.

To change the BSYAEIE bit from 0 (flash access error interrupt disabled) to 1 (flash access error interrupt enabled), make the setting as follows:

- (1) Read the BSYAEI bit in the FST register (dummy read).
- (2) Write 0 (no flash access error interrupt) to the BSYAEI bit.
- (3) Set the BSYAEIE bit to 1 (flash access error interrupt enabled).

RDYSTIE Bit (Flash Ready Status Interrupt Enable Bit)

This bit enables a flash ready status error interrupt to be generated when the status of the flash memory sequence changes from the busy to ready status.

To change the RDYSTIE bit from 0 (flash ready status interrupt disabled) to 1 (flash ready status interrupt enabled), make the setting as follows:

- (1) Read the RDYSTI bit in the FST register (dummy read).
- (2) Write 0 (no flash ready status interrupt) to the RDYSTI bit.
- (3) Set the RDYSTIE bit to 1 (flash ready status interrupt enabled).

28.4.3 Flash Memory Control Register 1 (FMR1) [R8C/33G Group]

Address 01B5h

Bit	b7	b6	b5	b4	b3	b2	b1	b0
Symbol	FMR17	FMR16	FMR15	FMR14	FMR13	—	—	—
After Reset	0	0	0	0	0	0	0	0

Bit	Symbol	Bit Name	Function	R/W
b0	—	Nothing is assigned. If necessary, set to 0. When read, the content is 0.		—
b1	—			
b2	—			
b3	FMR13	Lock bit disable select bit ⁽¹⁾	0: Lock bit enabled 1: Lock bit disabled	R/W
b4	FMR14	Data flash block A rewrite disable bit ^(2, 3)	0: Rewrite enabled (software command acceptable) 1: Rewrite disabled (software command not acceptable, no error occurred)	R/W
b5	FMR15	Data flash block B rewrite disable bit ^(2, 3)	0: Rewrite enabled (software command acceptable) 1: Rewrite disabled (software command not acceptable, no error occurred)	R/W
b6	FMR16	Data flash block C rewrite disable bit ^(2, 3)	0: Rewrite enabled (software command acceptable) 1: Rewrite disabled (software command not acceptable, no error occurred)	R/W
b7	FMR17	Data flash block D rewrite disable bit ^(2, 3)	0: Rewrite enabled (software command acceptable) 1: Rewrite disabled (software command not acceptable, no error occurred)	R/W

Notes:

1. To set the FMR13 bit to 1, first write 0 and then 1 immediately. Disable interrupts and DTC activation between writing 0 and writing 1.
2. To set this bit to 0, first write 1 and then 0 immediately. Disable interrupts and DTC activation between writing 1 and writing 0.
3. This bit is set to 0 when the FMR01 bit in the FMR0 register is set to 0 (CPU rewrite mode disabled).

FMR13 Bit (Lock Bit Disable Select Bit)

When the FMR13 bit is set to 1 (lock bit disabled), the lock bit is disabled. When the FMR13 bit is set to 0, the lock bit is enabled. Refer to **28.4.12 Data Protect Function** for the details of the lock bit.

The FMR13 bit enables the lock bit function only and the lock bit data does not change. However, when a block erase command is executed while the FMR13 bit is set to 1, the lock bit data set to 0 (locked) changes to 1 (not locked) after erasure completes.

[Conditions for setting to 0]

The FMR13 bit is set to 0 when one of the following conditions is met.

- Completion of the program command
- Completion of the erase command
- Generation of a command sequence error
- Transition to erase-suspend
- If the FMR01 bit in the FMR0 register is set to 0 (CPU rewrite mode disabled).
- If the FMSTP bit in the FMR0 register is set to 1 (flash memory stops).
- If the CMDRST bit in the FMR0 register is set to 1 (erasure/writing stopped).

[Condition for setting to 1]

Set to 1 by a program.

FMR14 Bit (Data Flash Block A Rewrite Disable Bit)

When the FMR 14 bit is set to 0, data flash block A accepts program and block erase commands.

FMR15 Bit (Data Flash Block B Rewrite Disable Bit)

When the FMR 15 bit is set to 0, data flash block B accepts program and block erase commands.

FMR16 Bit (Data Flash Block C Rewrite Disable Bit)

When the FMR 16 bit is set to 0, data flash block C accepts program and block erase commands.

FMR17 Bit (Data Flash Block D Rewrite Disable Bit)

When the FMR 17 bit is set to 0, data flash block D accepts program and block erase commands.

28.4.4 Flash Memory Control Register 1 (FMR1) [R8C/33H Group]

Address 01B5h

Bit	b7	b6	b5	b4	b3	b2	b1	b0
Symbol	—	—	—	—	FMR13	—	—	—
After Reset	0	0	0	0	0	0	0	0

Bit	Symbol	Bit Name	Function	R/W
b0	—	Nothing is assigned. If necessary, set to 0. When read, the content is 0.		—
b1	—			
b2	—			
b3	FMR13	Lock bit disable select bit ⁽¹⁾	0: Lock bit enabled 1: Lock bit disabled	R/W
b4	—	Reserved bits	Set to 0.	R/W
b5	—			
b6	—			
b7	—			

Note:

- To set the FMR13 bit to 1, first write 0 and then 1 immediately. Disable interrupts and DTC activation between writing 0 and writing 1.

FMR13 Bit (Lock Bit Disable Select Bit)

When the FMR13 bit is set to 1 (lock bit disabled), the lock bit is disabled. When the FMR13 bit is set to 0, the lock bit is enabled. Refer to **28.4.12 Data Protect Function** for the details of the lock bit.

The FMR13 bit enables the lock bit function only and the lock bit data does not change. However, when a block erase command is executed while the FMR13 bit is set to 1, the lock bit data set to 0 (locked) changes to 1 (not locked) after erasure completes.

[Conditions for setting to 0]

The FMR13 bit is set to 0 when one of the following conditions is met.

- Completion of the program command
- Completion of the erase command
- Generation of a command sequence error
- Transition to erase-suspend
- If the FMR01 bit in the FMR0 register is set to 0 (CPU rewrite mode disabled).
- If the FMSTP bit in the FMR0 register is set to 1 (flash memory stops).
- If the CMDRST bit in the FMR0 register is set to 1 (erasure/writing stopped).

[Condition for setting to 1]

Set to 1 by a program.

28.4.5 Flash Memory Control Register 2 (FMR2) [R8C/33G Group]

Address 01B6h

Bit	b7	b6	b5	b4	b3	b2	b1	b0
Symbol	FMR27	—	—	—	FMR23	FMR22	FMR21	FMR20
After Reset	0	0	0	0	0	0	0	0

Bit	Symbol	Bit Name	Function	R/W
b0	FMR20	Erase-suspend enable bit (1)	0: Erase-suspend disabled 1: Erase-suspend enabled	R/W
b1	FMR21	Erase-suspend request bit (2)	0: Erase restart 1: Erase-suspend request	R/W
b2	FMR22	Interrupt request suspend request enable bit (1)	0: Erase-suspend request disabled by interrupt request 1: Erase-suspend request enabled by interrupt request	R/W
b3	FMR23	Data flash access cycle selection bit (3)	0: 2 cycles of CPU clock 1: 4 cycles of CPU clock	R/W
b4	—	Reserved bits	Set to 0.	R/W
b5	—			
b6	—			
b7	FMR27	Low-current-consumption read mode enable bit (1, 4)	0: Low-current-consumption read mode disabled 1: Low-current-consumption read mode enabled	R/W

Notes:

- To set this bit to 1, first write 0 and then 1 immediately. Disable interrupts and DTC activation between writing 0 and writing 1.
- To set the FMR21 bit to 0 (erase restart), set it when the FMR01 bit in the FMR0 register is set to 1 (CPU rewrite mode enabled).
- To use the data flash with more than 16 MHz CPU clock, set this bit to 1 (4 cycles of the CPU clock).
- After setting the CPU clock to the low-speed on-chip oscillator clock divided by 4, 8, or 16, set the FMR27 bit to 1. When divided by 1 (no division) or divided by 2 is set, do not use low-current-consumption read mode. Enter wait mode or stop mode after setting the FMR27 bit to 0 (low-current-consumption read mode disabled). Do not enter wait mode or stop mode while the FMR27 bit is 1 (low-current-consumption read mode enabled).

FMR20 Bit (Erase-Suspend Enable Bit)

When the FMR20 bit is set to 1 (enabled), the erase-suspend function is enabled.

FMR21 Bit (Erase-Suspend Request Bit)

When the FMR21 bit is set to 1, erase-suspend mode is entered. If the FMR22 bit is set to 1 (erase-suspend request enabled by interrupt request), the FMR21 bit is automatically set to 1 (erase-suspend request) when an interrupt request for the enabled interrupt is generated, and erase-suspend mode is entered. To restart auto-erasure, set the FMR21 bit to 0 (erase restart).

[Condition for setting to 0]

Set to 0 by a program.

[Conditions for setting to 1]

- When the FMR22 bit is set to 1 (erase-suspend request enabled by interrupt request) at the time an interrupt is generated.
- Set to 1 by a program.

FMR22 Bit (Interrupt Request Suspend-Request Enable Bit)

When the FMR 22 bit is set to 1 (erase-suspend request enabled by interrupt request), the FMR21 bit is automatically set to 1 (erase-suspend request) at the time an interrupt request is generated during auto-erasure. Set the FMR22 bit to 1 when using erase-suspend while rewriting the user ROM area in EW1 mode.

FMR23 bit (data flash access cycle selection bit)

When the FMR23 bit is set to 1, the read timing of the data flash is changed from 2 cycles of CPU clock usually to four cycles. The access to program ROM area, SFR, and the RAM area is not changed. To use the data flash with more than 16 MHz CPU clock, set this bit to 1 (4 cycles of the CPU clock).

FMR27 Bit (Low-Current-Consumption Read Mode Enable Bit)

When the FMR 27 bit is set to 1 (low-current-consumption read mode enabled) in low-speed on-chip oscillator mode (XIN clock stopped), power consumption when reading the flash memory can be reduced. Refer to **29.2.11 Low-Current-Consumption Read Mode** for details.

When the CPU clock is set to the low-speed on-chip oscillator clock divided by 4, 8, or 16, low-current-consumption read mode can be used. When divided by 1 (no division) or divided by 2 is set, do not use low-current-consumption read mode.

After setting the divide ratio of the CPU clock, set the FMR27 bit to 1.

Enter wait mode or stop mode after setting the FMR27 bit to 0 (low-current-consumption read mode disabled). Do not enter wait mode or stop mode while the FMR27 bit is 1 (low-current-consumption read mode enabled). When the FMR27 bit is set to 1 (low-current-consumption read mode enabled), do not execute the program, block erase, or lock bit program command. To change the FMSTP bit from 1 (flash memory stops) to 0 (flash memory operates), make the setting when the FMR27 bit is set to 0 (low-current-consumption read mode disabled).

28.4.6 Flash Memory Control Register 2 (FMR2) [R8C/33H Group]

Address 01B6h

Bit	b7	b6	b5	b4	b3	b2	b1	b0
Symbol	FMR27	—	—	—	—	FMR22	FMR21	FMR20
After Reset	0	0	0	0	0	0	0	0

Bit	Symbol	Bit Name	Function	R/W
b0	FMR20	Erase-suspend enable bit (1)	0: Erase-suspend disabled 1: Erase-suspend enabled	R/W
b1	FMR21	Erase-suspend request bit (2)	0: Erase restart 1: Erase-suspend request	R/W
b2	FMR22	Interrupt request suspend request enable bit (1)	0: Erase-suspend request disabled by interrupt request 1: Erase-suspend request enabled by interrupt request	R/W
b3	—	Nothing is assigned. If necessary, set to 0. When read, the content is 0.		—
b4	—	Reserved bits	Set to 0.	R/W
b5	—			
b6	—			
b7	FMR27	Low-current-consumption read mode enable bit (1, 3)	0: Low-current-consumption read mode disabled 1: Low-current-consumption read mode enabled	R/W

Notes:

- To set this bit to 1, first write 0 and then 1 immediately. Disable interrupts and DTC activation between writing 0 and writing 1.
- To set the FMR21 bit to 0 (erase restart), set it when the FMR01 bit in the FMR0 register is set to 1 (CPU rewrite mode enabled).
- After setting the CPU clock to the low-speed on-chip oscillator clock divided by 4, 8, or 16, set the FMR27 bit to 1. When divided by 1 (no division) or divided by 2 is set, do not use low-current-consumption read mode. Enter wait mode or stop mode after setting the FMR27 bit to 0 (low-current-consumption read mode disabled). Do not enter wait mode or stop mode while the FMR27 bit is 1 (low-current-consumption read mode enabled).

FMR20 Bit (Erase-Suspend Enable Bit)

When the FMR20 bit is set to 1 (enabled), the erase-suspend function is enabled.

FMR21 Bit (Erase-Suspend Request Bit)

When the FMR21 bit is set to 1, erase-suspend mode is entered. If the FMR22 bit is set to 1 (erase-suspend request enabled by interrupt request), the FMR21 bit is automatically set to 1 (erase-suspend request) when an interrupt request for the enabled interrupt is generated, and erase-suspend mode is entered. To restart auto-erasure, set the FMR21 bit to 0 (erase restart).

[Condition for setting to 0]

Set to 0 by a program.

[Conditions for setting to 1]

- When the FMR22 bit is set to 1 (erase-suspend request enabled by interrupt request) at the time an interrupt is generated.
- Set to 1 by a program.

FMR22 Bit (Interrupt Request Suspend-Request Enable Bit)

When the FMR 22 bit is set to 1 (erase-suspend request enabled by interrupt request), the FMR21 bit is automatically set to 1 (erase-suspend request) at the time an interrupt request is generated during auto-erasure. Set the FMR22 bit to 1 when using erase-suspend while rewriting the user ROM area in EW1 mode.

FMR27 Bit (Low-Current-Consumption Read Mode Enable Bit)

When the FMR 27 bit is set to 1 (low-current-consumption read mode enabled) in low-speed on-chip oscillator mode (XIN clock stopped), power consumption when reading the flash memory can be reduced. Refer to **29.2.11 Low-Current-Consumption Read Mode** for details.

When the CPU clock is set to the low-speed on-chip oscillator clock divided by 4, 8, or 16, low-current-consumption read mode can be used. When divided by 1 (no division) or divided by 2 is set, do not use low-current-consumption read mode.

After setting the divide ratio of the CPU clock, set the FMR27 bit to 1.

Enter wait mode or stop mode after setting the FMR27 bit to 0 (low-current-consumption read mode disabled). Do not enter wait mode or stop mode while the FMR27 bit is 1 (low-current-consumption read mode enabled). When the FMR27 bit is set to 1 (low-current-consumption read mode enabled), do not execute the program, block erase, or lock bit program command. To change the FMSTP bit from 1 (flash memory stops) to 0 (flash memory operates), make the setting when the FMR27 bit is set to 0 (low-current-consumption read mode disabled).

28.4.7 EW0 Mode

When the FMR01 bit in the FMR0 register is set to 1 (CPU rewrite mode enabled), the MCU enters CPU rewrite mode and software commands can be accepted. At this time, the FMR02 bit in the FMR0 register is set to 0 so that EW0 mode is selected.

Software commands are used to control program and erase operations. The FST register can be used to confirm whether programming or erasure has completed.

To enter erase-suspend during auto-erasure, set the FMR20 bit to 1 (erase-suspend enabled) and the FMR21 bit to 1 (erase-suspend request). Next, verify the FST7 bit in the FST register is set to 1 (ready), then verify the FST6 bit is set to 1 (during erase-suspend) before accessing the flash memory. When the FST6 bit is set to 0, erasure completes.

When the FMR21 bit in the FMR2 register is set to 0 (erase restart), auto-erasure restarts. To confirm whether auto-erasure has restarted, verify the FST7 bit in the FST register is set to 0, then verify the FST6 bit is set to 0 (other than erase-suspend).

28.4.8 EW1 Mode

After the FMR01 bit in the FMR0 register is set to 1 (CPU rewrite mode enabled), EW1 mode is selected by setting the FMR02 bit is set to 1.

The FST register can be used to confirm whether programming and erasure has completed.

To enable the erase-suspend function during auto-erasure, execute the block erase command after setting the FMR20 bit in the FMR2 register to 1 (suspend enabled). To enter erase-suspend while auto-erasing the user ROM area, set the FMR22 bit in the FMR2 register to 1 (erase-suspend request enabled by interrupt request). Also, the interrupt to enter erase-suspend must be enabled beforehand.

When an interrupt request is generated, the FMR21 bit in the FMR2 register is automatically set to 1 (erase-suspend request) and auto-erasure suspends after $t_d(SR-SUS)$. After interrupt handling completes, set the FMR21 bit to 0 (erase restart) to restart auto-erasure.

28.4.9 Suspend Operation

The suspend function halts the auto-erase operation temporarily during auto-erasure. When auto-erasure is suspended, the next operation can be executed. (Refer to **Table 28.5 Executable Operation during Suspend**.)

- When suspending the auto-erasure of any block in data flash (only for R8C/33G Group), auto-programming and reading another block can be executed.
- When suspending the auto-erasure of data flash, auto-programming and reading program ROM can be executed.
- When suspending the auto-erasure of any block in program ROM, auto-programming and reading another block can be executed.
- When suspending the auto-erasure of program ROM, auto-programming and reading data flash can be executed.
- To check the suspend, verify the FST7 bit is set to 1 (ready), then verify the FST6 bit is set to 1 (during erase-suspend) to confirm whether erasure has been suspended. When the FST6 bit is set to 0 (other than erase suspend), erasure completes.

Figure 28.3 shows the Suspend Operation Timing.

Table 28.5 Executable Operation during Suspend

		Operation during Suspend											
		Data flash (Block during erasure execution before entering suspend)			Data flash (Block during no erasure execution before entering suspend)			Program ROM (Block during erasure execution before entering suspend)			Program ROM (Block during no erasure execution before entering suspend)		
		Erase	Program	Read	Erase	Program	Read	Erase	Program	Read	Erase	Program	Read
Areas during erasure execution before entering suspend	Data flash	D	D	D	D	E	E	N/A	N/A	N/A	D	E	E (5)
	Program ROM	N/A	N/A	N/A	D	E	E	D	D	D	D	E	E

Notes:

1. E indicates operation is enabled by using the suspend function, D indicates operation is disabled, and N/A indicates no combination is available.
2. Operation cannot be suspended during programming.
3. The block erase command can be executed for erasure. The program, lock bit program, and read lock bit status commands can be executed for programming. The clear status register command can be executed when the FST7 bit in the FST register is set to 1 (ready).
4. The MCU enters read array mode immediately after entering erase-suspend.
5. The program ROM area can be read with the BGO function while programming or block erasing data flash.
6. The R8C/33G Group has data flash.

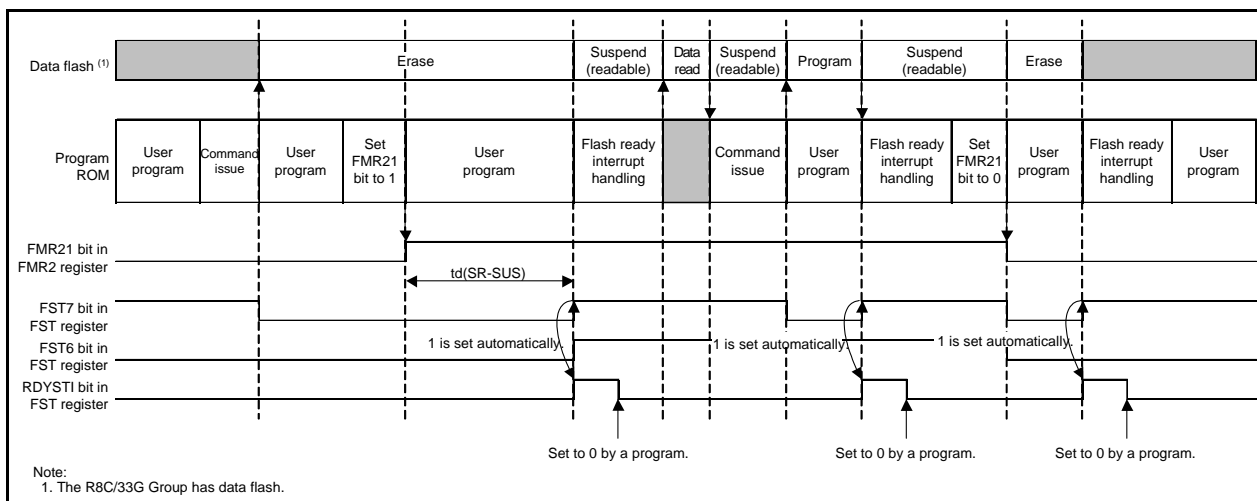

Figure 28.3 Suspend Operation Timing

28.4.10 How to Set and Exit Each Mode

Figure 28.4 shows How to Set and Exit EW0 Mode and Figure 28.5 shows How to Set and Exit EW0 Mode (When Rewriting Data Flash) and EW1 Mode.

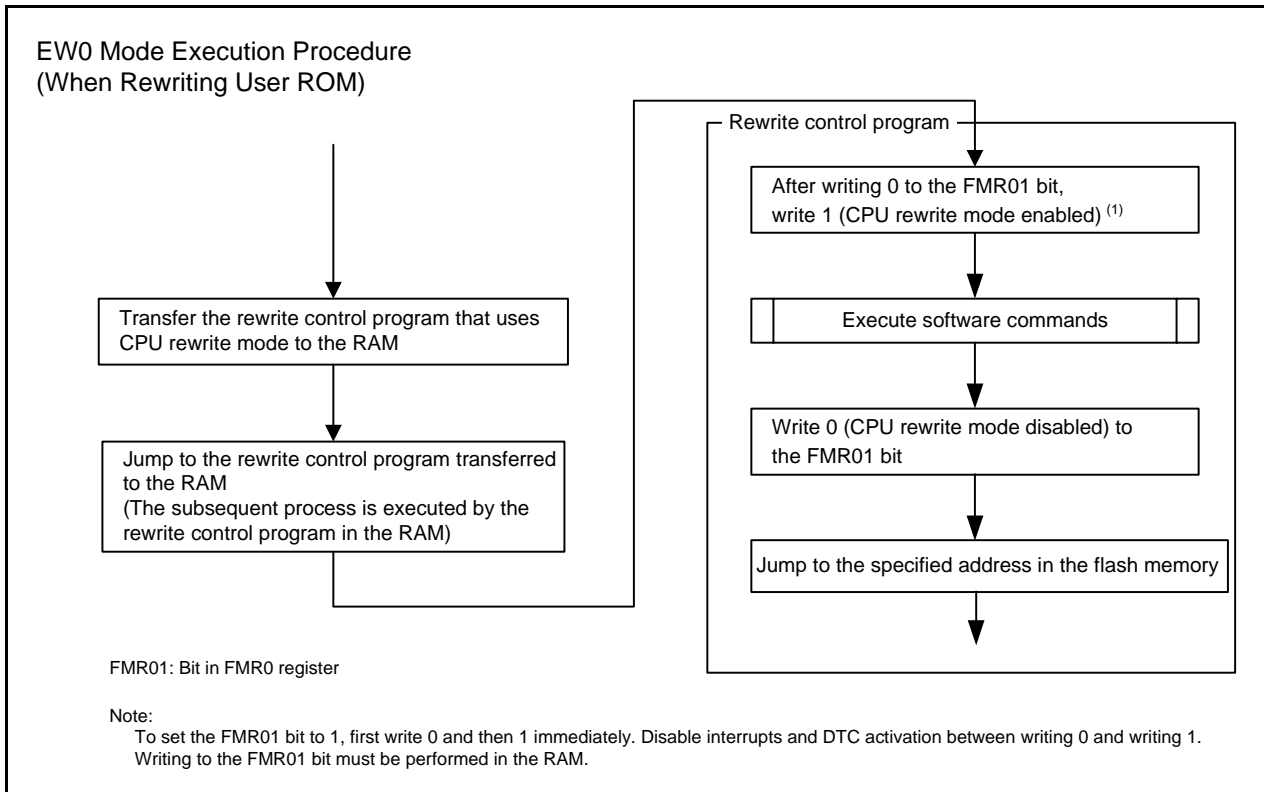

Figure 28.4 How to Set and Exit EW0 Mode

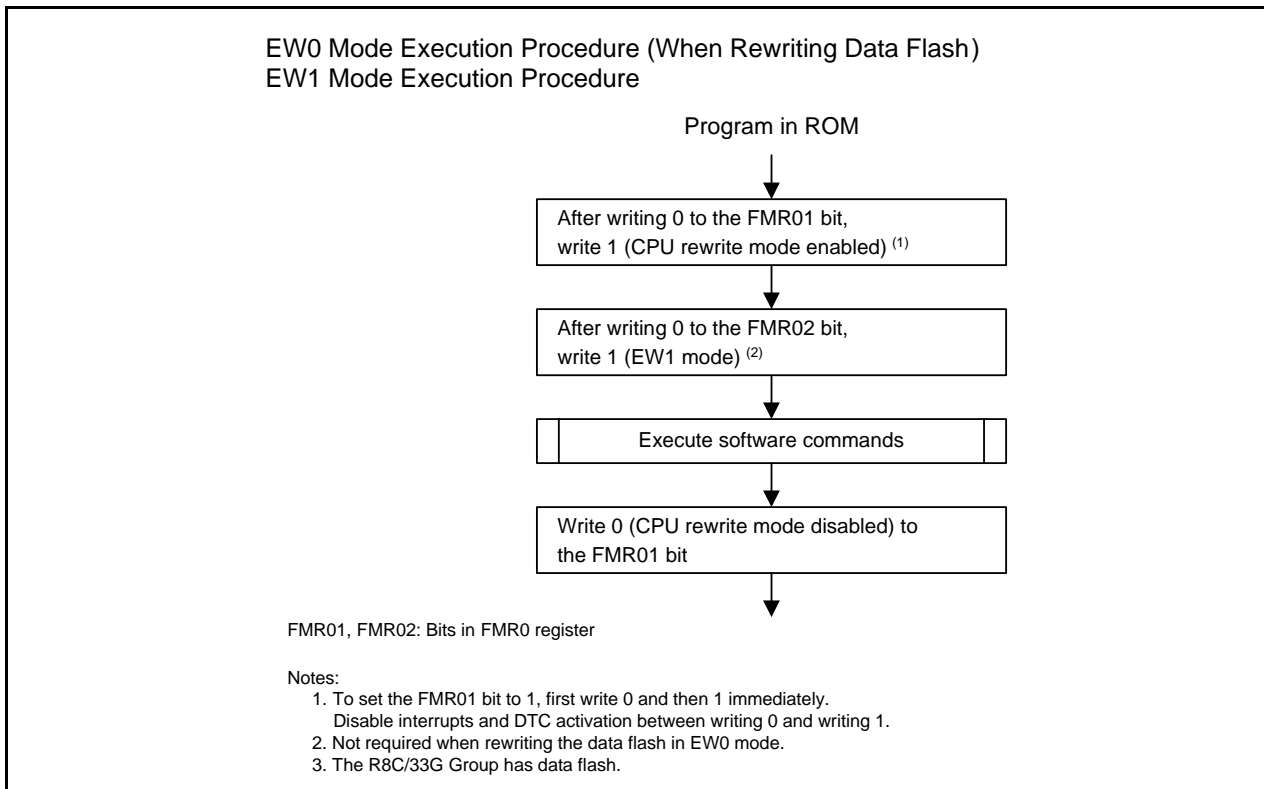

Figure 28.5 How to Set and Exit EW0 Mode (When Rewriting Data Flash) and EW1 Mode

28.4.11 BGO (BackGround Operation) Function [R8C/33G Group]

When the program ROM area is specified while a program or block erase operation to the data flash, array data can be read. This eliminates the need for writing software commands. Access time is the same as for normal read operations.

Any other block of the data flash cannot read during a program or block erase operation to the data flash.

Figure 28.6 shows the BGO Function.

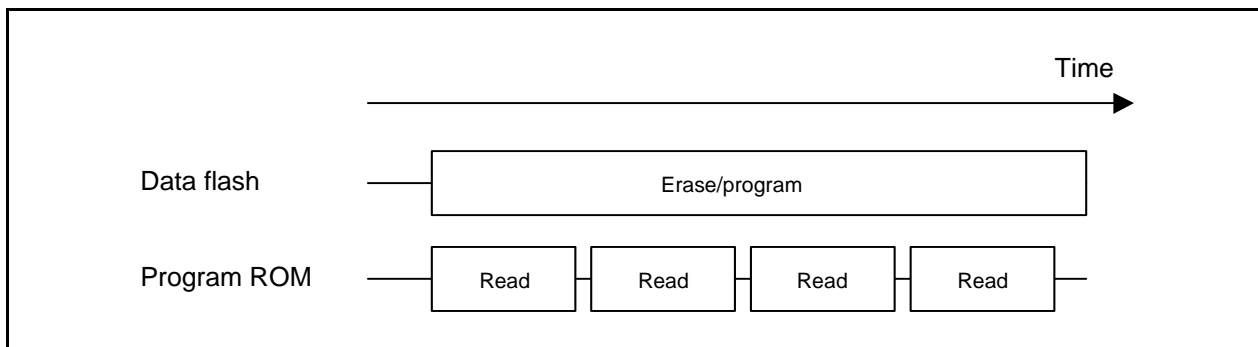

Figure 28.6 BGO Function

28.4.12 Data Protect Function

Each block in the flash memory has a nonvolatile lock bit. The lock bit is enabled by setting the FMR13 bit in the FMR1 register is set to 0 (lock bit enabled). The lock bit can be used to disable (lock) programming or erasing each block. This prevents data from being written or erased inadvertently. A block status changes according to the lock bit as follows:

- When the lock bit data is set to 0: locked (the block cannot be programmed or erased)
- When the lock bit data is set to 1: not locked (the block can be programmed and erased)

The lock bit data is set to 0 (locked) by executing the lock bit program command and to 1 (not locked) by erasing the block. No commands can be used to set only the lock bit data to 1.

The lock bit data can be read using the read lock bit status command.

When the FMR13 bit is set to 1 (lock bit disabled), the lock bit function is disabled and all blocks are not locked (each lock bit data remains unchanged). The lock bit function is enabled by setting the FMR13 bit to 0 (the lock bit data is retained).

When the block erase command is executed while the FMR13 bit is set to 1, the target block is erased regardless of the lock bit status. The lock bit of the erase target block is set to 1 after auto-erasure completes.

Refer to **28.4.13 Software Commands** for the details of individual commands.

The FMR13 bit is set to 0 after auto-erasure completes. This bit is also set to 0 if one of the following conditions is met. To erase or program a different locked block, set the FMR 13 bit to 1 again and execute the block erase or program command.

- If the FST7 bit in the FST register is changed from 0 (busy) to 1 (ready).
- If a command sequence error occurs.
- If the FMR01 bit in the FMR0 register is set to 0 (CPU mode disabled).
- If the FMSTP bit in the FM0 register is set to 1 (flash memory stops).
- If the CMDRST bit in the FMR0 register is set to 1 (erasure/writing stopped).

Figure 28.7 shows the FMR13 Bit Operation Timing.

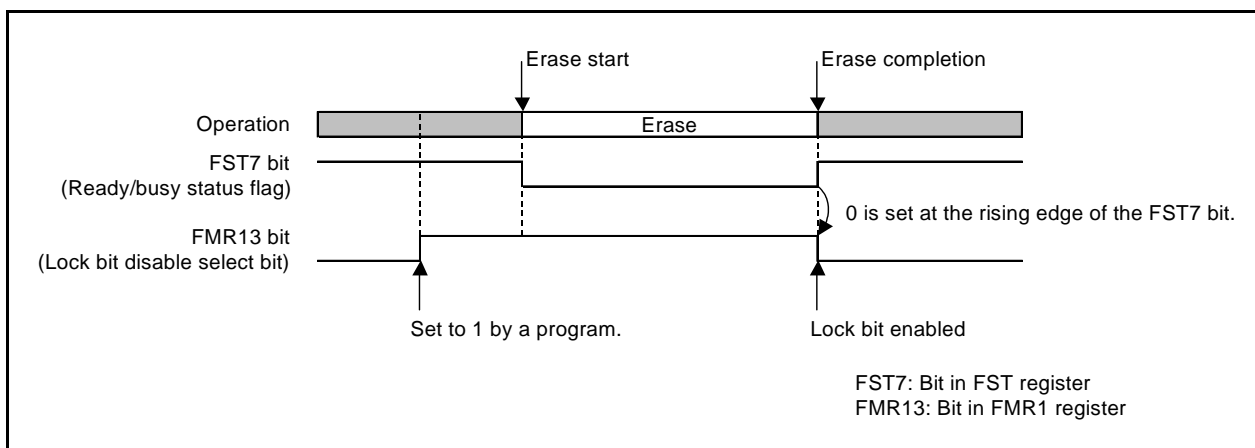

Figure 28.7 FMR13 Bit Operation Timing

28.4.13 Software Commands

The software commands are described below. Read or write commands and data in 8-bit units.
Do not input any command other than those listed in the table below.

Table 28.6 Software Commands

Command	First Bus Cycle			Second Bus Cycle		
	Mode	Address	Data	Mode	Address	Data
Read array	Write	x	FFh			
Clear status register	Write	x	50h			
Program	Write	WA	40h	Write	WA	WD
Block erase	Write	x	20h	Write	BA	D0h
Lock bit program	Write	BT	77h	Write	BT	D0h
Read lock bit status	Write	x	71h	Write	BT	D0h

WA: Write address

WD: Write data

BA: Any block address

BT: Starting block address

x: Any address in the user ROM area

28.4.13.1 Read Array Command

The read array command is used to read the flash memory.

When FFh is written in the first bus cycle, the MCU enters read array mode. When the read address is input in the following bus cycles, the content of the specified address can be read in 8-bit units.

Since read array mode remains until another command is written, the contents of multiple addresses can be read continuously.

In addition, after a reset, the MCU enters read array mode after a program, block erase, read lock bit status, or clear status register command, or after entering erase-suspend.

28.4.13.2 Clear Status Register Command

The clear status register command is used to set bits FST4 and FST5 in the FST register to 0.

When 50h is written in the first bus cycle, bits FST4 and FST5 in the FST register are set to 0.

28.4.13.3 Program Command

The program command is used to write data to the flash memory in 1-byte units.

When 40h is written in the first bus cycle and data is written in the second bus cycle to the write address, auto-programming (data program and verify operation) starts. Make sure the address value specified in the first bus cycle is the same address as the write address specified in the second bus cycle.

The FST7 bit in the FST register can be used to confirm whether auto-programming has completed. The FST7 bit is set to 0 during auto-programming and is set to 1 when auto-programming completes.

After auto-programming has completed, the auto-program result can be confirmed by the FST4 bit in the FST register (refer to **28.4.14 Full Status Check**).

Do not write additions to the already programmed addresses.

The program command targeting each block in the program ROM can be disabled using the lock bit.

As for the R8C/33G Group, following commands are not accepted under the following conditions:

- Program commands targeting data flash block A when the FMR14 bit in the FMR1 register is set to 1 (rewrite disabled).
- Program commands targeting data flash block B when the FMR15 bit is set to 1 (rewrite disabled).
- Program commands targeting data flash block C when the FMR16 bit is set to 1 (rewrite disabled).
- Program commands targeting data flash block D when the FMR17 bit is set to 1 (rewrite disabled).

Figure 28.8 shows a Program Flowchart (Flash Ready Status Interrupt Disabled) and Figure 28.9 shows a Program Flowchart (Flash Ready Status Interrupt Enabled).

In EW1 mode, do not execute this command to any address where a rewrite control program is allocated.

When the RDYSTIE bit in the FMR0 register is set to 1 (flash ready status interrupt enabled), a flash ready status interrupt can be generated upon completion of auto-programming. The auto-program result can be confirmed by reading the FST register during the interrupt routine.

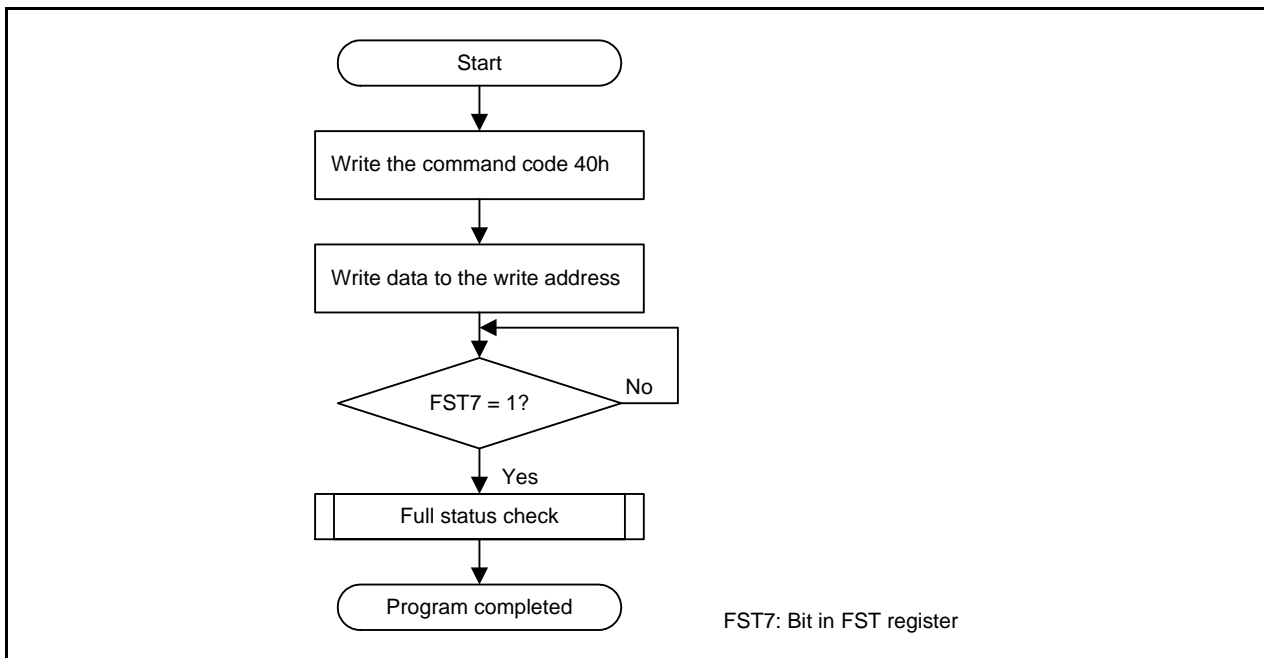

Figure 28.8 Program Flowchart (Flash Ready Status Interrupt Disabled)

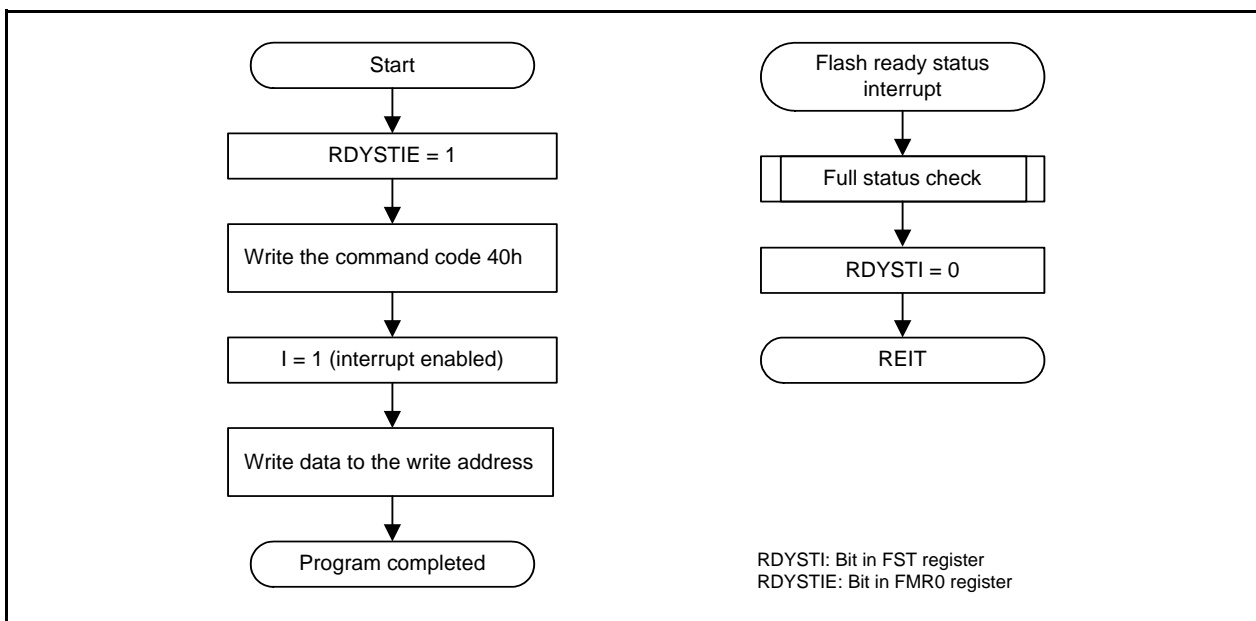

Figure 28.9 Program Flowchart (Flash Ready Status Interrupt Enabled)

28.4.13.4 Block Erase Command

When 20h is written in the first bus cycle and then D0h is written in the second bus cycle to any block address, auto-erasure (erase and erase verify operation) starts in the specified block.

The FST7 bit in the FST register can be used to confirm whether auto-erasure has completed. The FST7 bit is set to 0 during auto-erasure and is set to 1 when auto-erasure completes. After auto-erasure completes, all data in the block is set to FFh.

After auto-erasure has completed, the auto-erase result can be confirmed by the FST5 bit in the FST register. (Refer to **28.4.14 Full Status Check**).

The block erase command targeting each block in the program ROM can be disabled using the lock bit. As for the R8C/33G Group, following commands are not accepted under the following conditions:

- Block erase commands targeting data flash block A when the FMR14 bit in the FMR1 register is set to 1 (rewrite disabled).
- Block erase commands targeting data flash block B when the FMR15 bit is set to 1 (rewrite disabled).
- Block erase commands targeting data flash block C when the FMR16 bit is set to 1 (rewrite disabled).
- Block erase commands targeting data flash block D when the FMR17 bit is set to 1 (rewrite disabled).

Figure 28.10 shows a Block Erase Flowchart in EW0 Mode (Flash Ready Status Interrupt Disabled), Figure 28.11 shows a Block Erase Flowchart in EW0 Mode (Flash Ready Status Interrupt Disabled and Suspend Enabled), Figure 28.12 shows a Block Erase Flowchart in EW0 Mode (Flash Ready Status Interrupt Enabled and Suspend Enabled), and Figure 28.13 shows a Block Erase Flowchart in EW1 Mode (Flash Ready Status Interrupt Disabled and Suspend Enabled).

In EW1 mode, do not execute this command to any block where a rewrite control program is allocated.

While the RDYSTIE bit in the FMR0 register is set to 1 (flash ready status interrupt enabled), a flash ready status interrupt can be generated upon completion of auto-erasure. While the RDYSTIE bit is set to 1 and the FMR20 bit in the FMR2 register is set to 1 (erase-suspend enabled), a flash ready status interrupt is generated when the FMR21 bit is set to 1 (erase-suspend request) and auto-erasure suspends. The auto-erase result can be confirmed by reading the FST register during the interrupt routine.

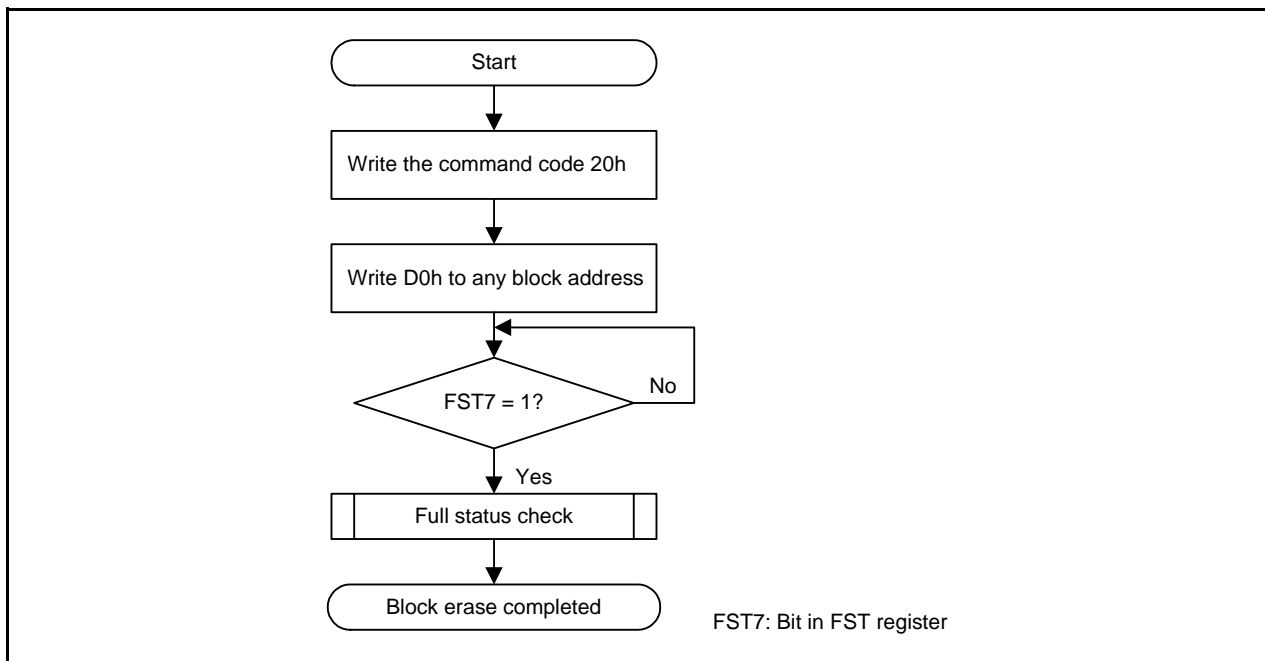

Figure 28.10 Block Erase Flowchart in EW0 Mode (Flash Ready Status Interrupt Disabled)

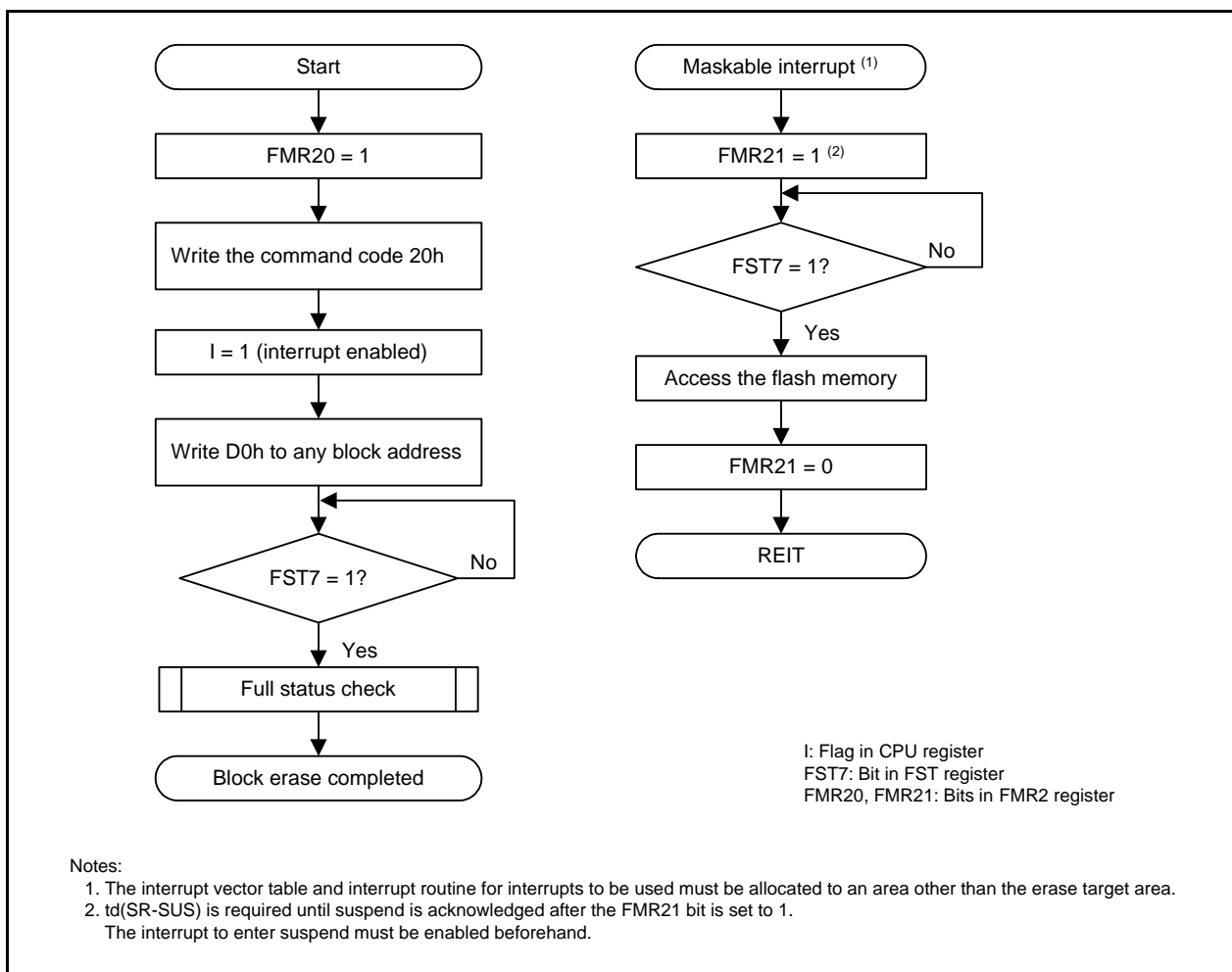

Figure 28.11 Block Erase Flowchart in EW0 Mode (Flash Ready Status Interrupt Disabled and Suspend Enabled)

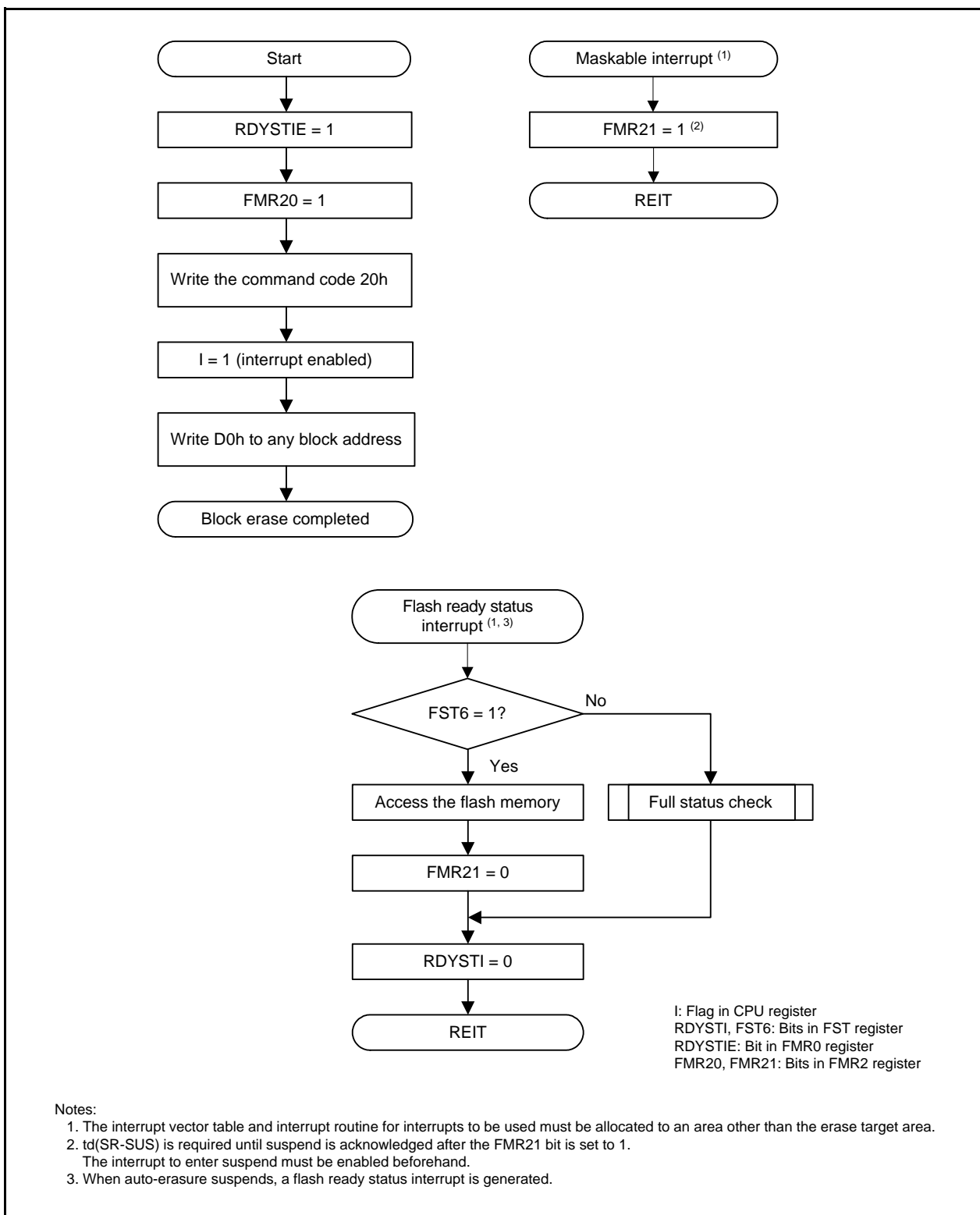

Figure 28.12 Block Erase Flowchart in EW0 Mode (Flash Ready Status Interrupt Enabled and Suspend Enabled)

When the FMR 22 bit is set to 1 (suspend request enabled by interrupt request), the FMR21 bit is automatically set to 1 (suspend request) when an interrupt request is generated during auto-erasure. Set the FMR22 bit to 1 when suspend is used while the user ROM area is auto-erased in EW1 mode.

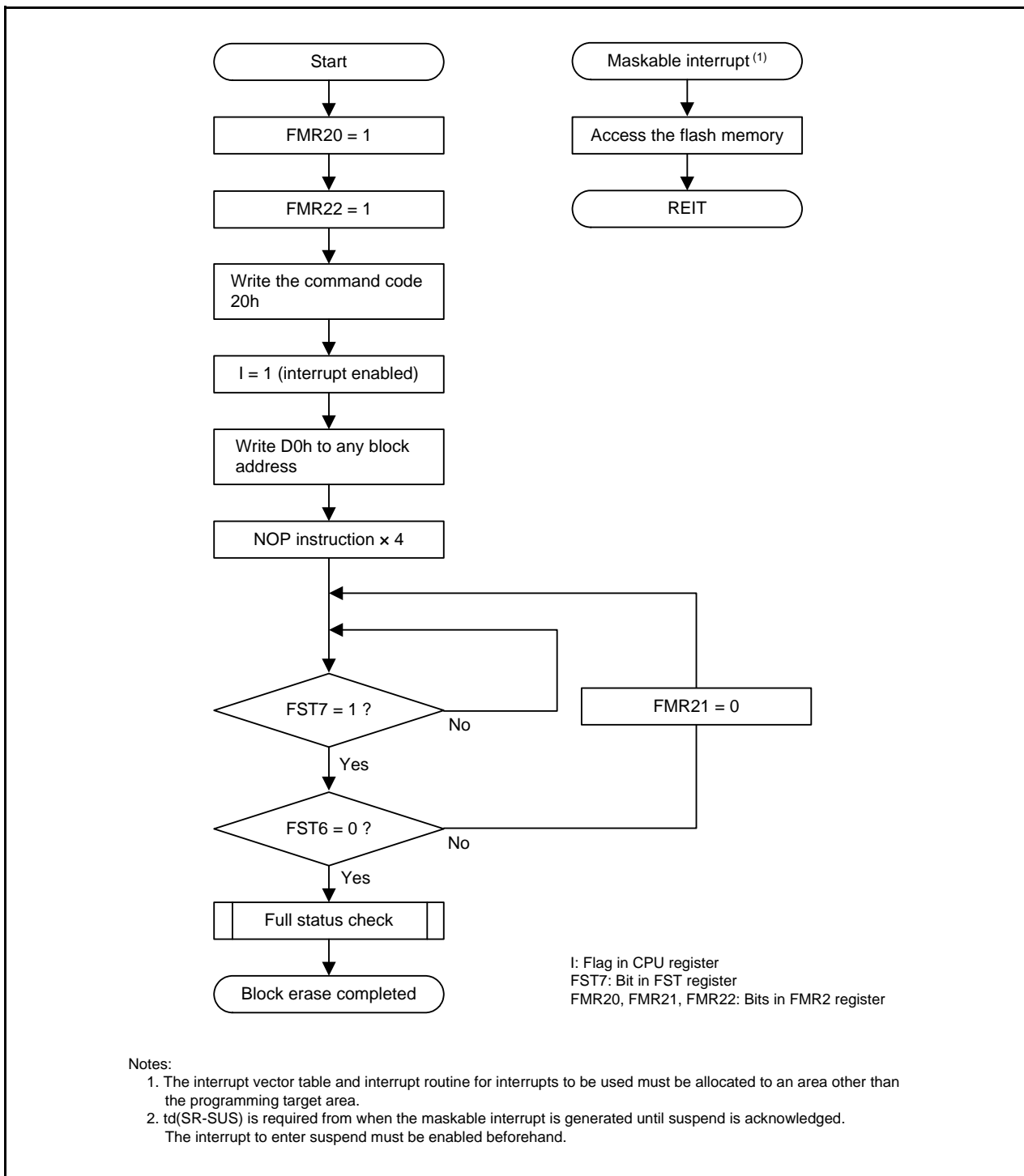

Figure 28.13 Block Erase Flowchart in EW1 Mode (Flash Ready Status Interrupt Disabled and Suspend Enabled)

28.4.13.5 Lock Bit Program Command

This command is used to set the lock bit of any block in the program ROM area to 0 (locked).

When 77h is written in the first bus cycle and D0h is written in the second bus cycle to the starting block address, 0 is written to the lock bit of the specified block. Make sure the address value in the first bus cycle is the same address as the starting block address specified in the second bus cycle.

Figure 28.14 shows a Lock Bit Program Flowchart. The lock bit status (lock bit data) can be read using the read lock bit status command.

The FST7 bit in the FST register can be used to confirm whether writing to the lock bit has completed.

Refer to **28.4.12 Data Protect Function** for the lock bit function and how to set the lock bit to 1 (not locked).

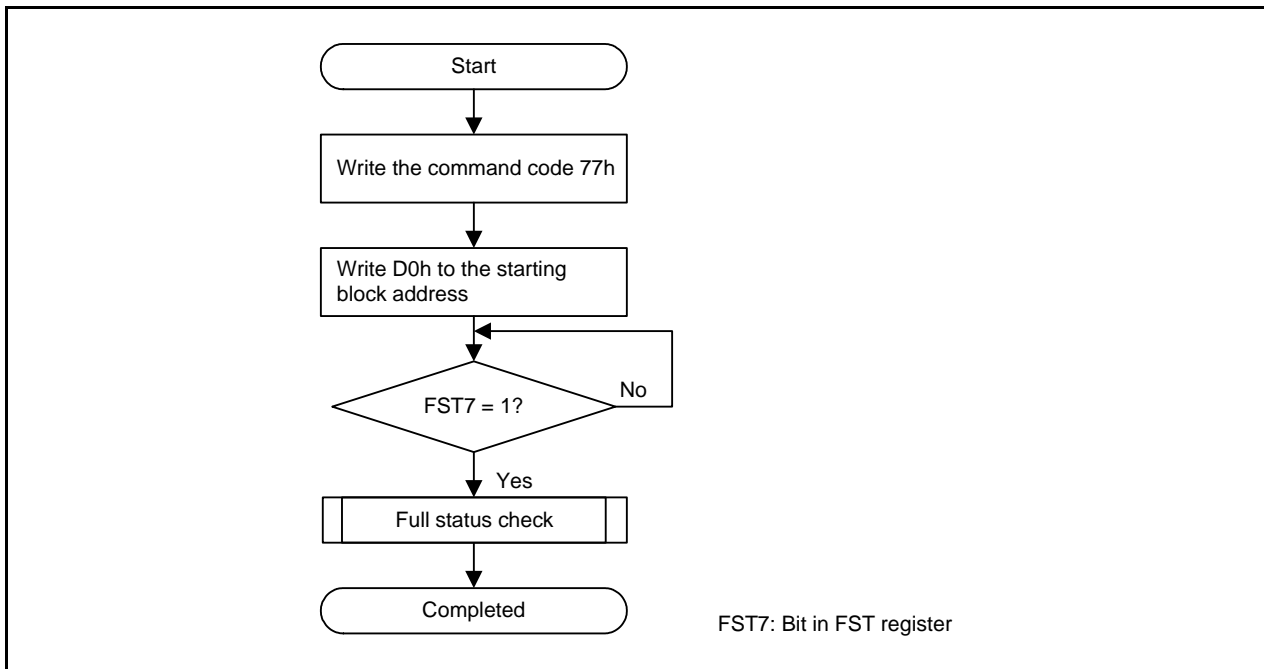

Figure 28.14 Lock Bit Program Flowchart

28.4.13.6 Read Lock Bit Status Command

This command is used to read the lock bit status of any block in the program ROM area.

When 71h written in the first bus cycle and D0h is written in the second cycle to the starting block address, the lock bit status of the specified block is stored in the LBDATA bit in the FST register. After the FST7 bit in the FST register has been set to 1 (ready), read the LBDATA bit.

Figure 28.15 shows a Read Lock Bit Status Flowchart.

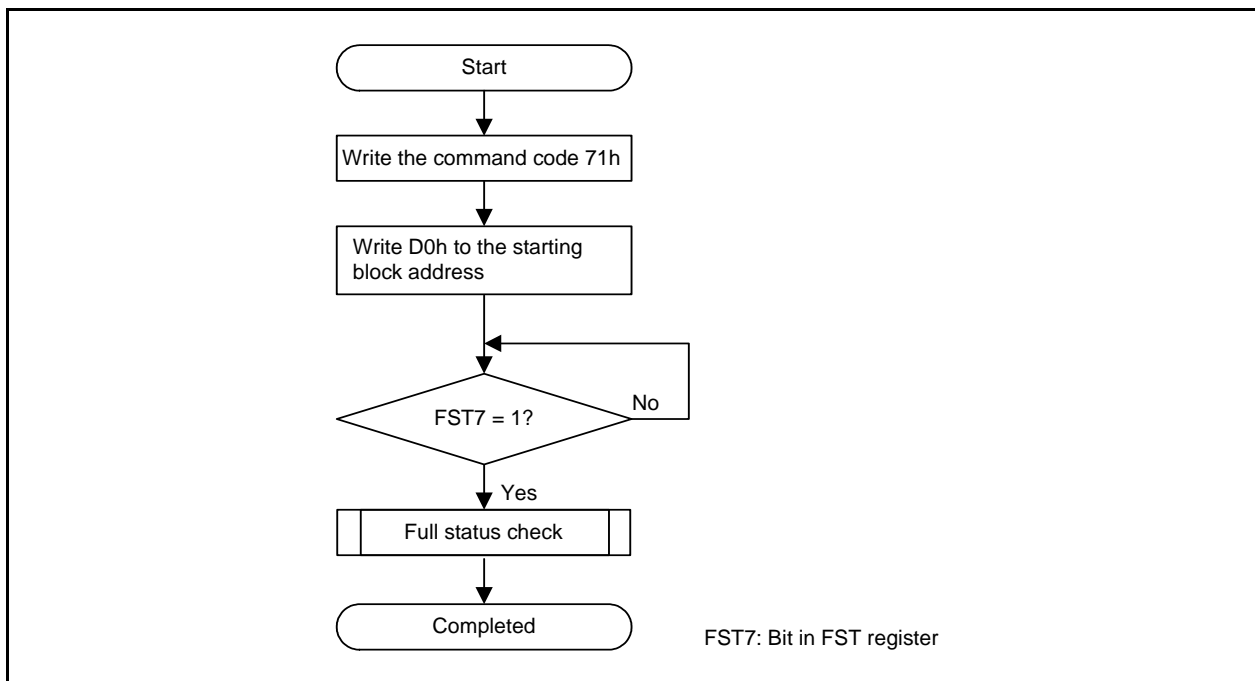

Figure 28.15 Read Lock Bit Status Flowchart

28.4.14 Full Status Check

If an error occurs, bits FST4 and FST5 in the FST register are set to 1, indicating the occurrence of an error. The execution result can be confirmed by checking these status bits (full status check).

Table 28.7 lists the Errors and FST Register Status. Figure 28.16 shows the Full Status Check and Handling Procedure for Individual Errors.

Table 28.7 Errors and FST Register Status

FST Register Status		Error	Error Occurrence Condition
FST5	FST4		
1	1	Command sequence error	<ul style="list-style-type: none"> • When a command is not written correctly. • When data other than valid data (i.e., D0h or FFh) is written in the second bus cycle of the block erase command ⁽¹⁾. • The erase command is executed during suspend • The command is executed to the block during suspend
1	0	Erase error	When the block erase command is executed, but auto-erasure does not complete correctly.
0	1	Program error	When the program command is executed, but auto-programming does not complete correctly.
		Lock bit program error	When the lock bit command is executed, but the lock bit is not set to 0 (locked).

Note:

1. When FFh is written in the second bus cycle of these commands, the MCU enters read array mode. At the same time, the command code written in the first bus cycle is invalid.

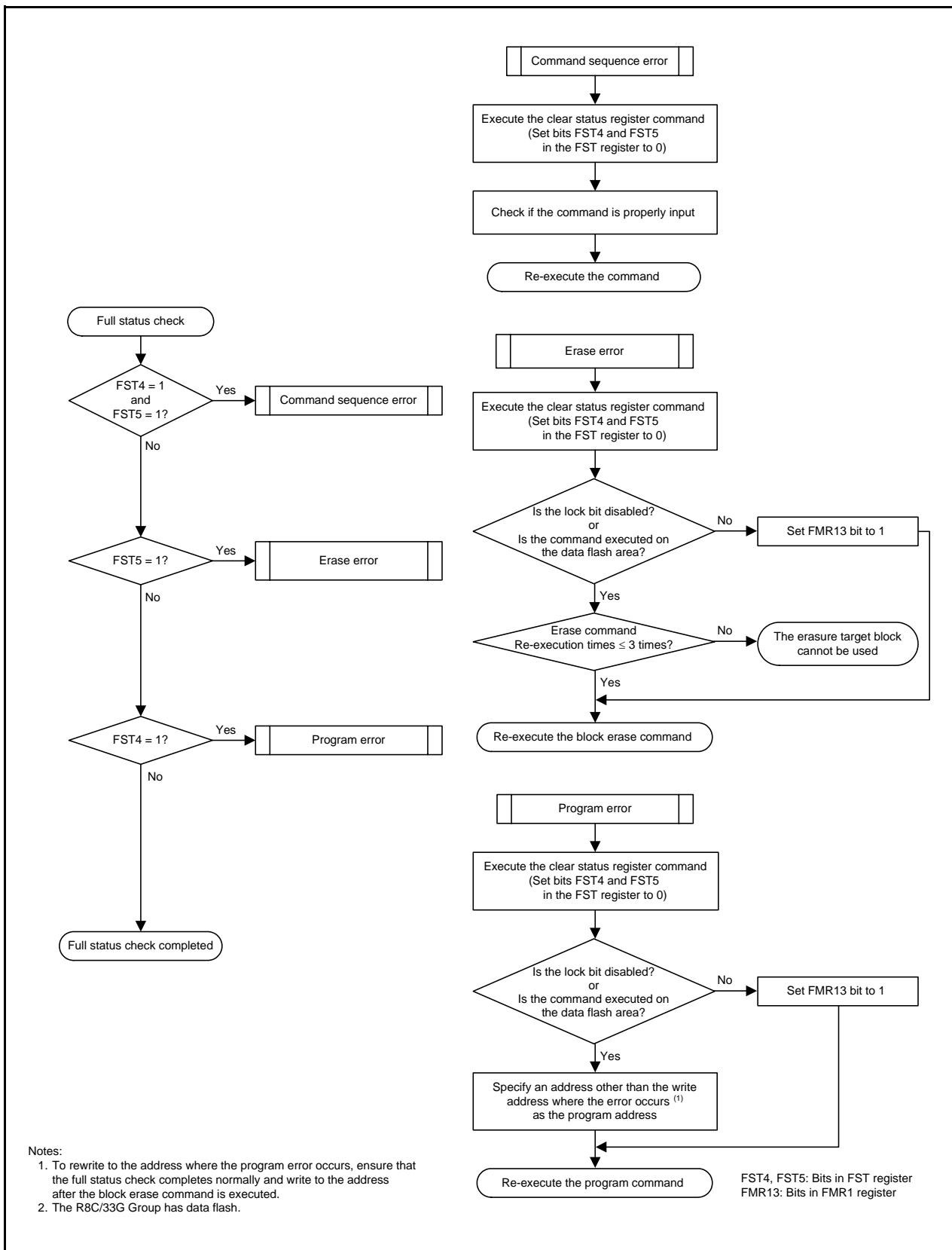

Figure 28.16 Full Status Check and Handling Procedure for Individual Errors

28.5 Standard Serial I/O Mode

In standard serial I/O mode, a serial programmer which supports the MCU can be used to rewrite the user ROM area while the MCU is mounted on-board.

There are three types of standard serial I/O modes:

- Standard serial I/O mode 1Clock synchronous serial I/O used to connect to a serial programmer
- Standard serial I/O mode 2Clock asynchronous serial I/O used to connect to a serial programmer
- Standard serial I/O mode 3Special clock asynchronous serial I/O used to connect to a serial programmer

Standard serial I/O mode 2 and standard serial I/O mode 3 can be used for the MCU.

Refer to **Appendix 2. Connection Examples between Serial Programmer and On-Chip Debugging Emulator** for examples of connecting to a serial programmer. Contact the serial programmer manufacturer for more information. Refer to the user's manual included with your serial programmer for instructions.

Table 28.8 lists the Pin Functions (Flash Memory Standard Serial I/O Mode 2) and Figure 28.17 shows Pin Handling in Standard Serial I/O Mode 2. Table 28.9 lists the Pin Functions (Flash Memory Standard Serial I/O Mode 3) and Figure 28.18 shows Pin Handling in Standard Serial I/O Mode 3.

After handling the pins shown in Table 28.9 and rewriting the flash memory using the programmer, apply a "H" level signal to the MODE pin and reset the hardware to run a program in the flash memory in single-chip mode.

28.5.1 ID Code Check Function

The ID code check function determines whether the ID codes sent from the serial programmer and those written in the flash memory match.

Refer to **12. ID Code Areas** for details of the ID code check.

Table 28.8 Pin Functions (Flash Memory Standard Serial I/O Mode 2)

Pin	Name	I/O	Description
VCC, VSS	Power supply input		Apply the guaranteed programming and erasure voltage to the VCC pin and 0 V to the VSS pin.
RESET	Reset input	I	Reset input pin
P4_6/XIN	P4_6 input/clock input	I	Connect a ceramic resonator or crystal oscillator between pins XIN and XOUT.
P4_7/XOUT	P4_7 input/clock output	I/O	
P4_3/XIN	P4_3 input/clock input	I	Connect a crystal oscillator between pins XCIN and XCOU.
P4_4/XOUT	P4_4 input/clock output	I/O	
P0_0 to P0_7	Input port P0	I	Input a "H" or "L" level signal or leave open.
P1_0 to P1_3, P1_6, P1_7	Input port P1	I	Input a "H" or "L" level signal or leave open.
P3_1, P3_3 to P3_7	Input port P3	I	Input a "H" or "L" level signal or leave open.
P4_2/VREF, P4_5	Input port P4	I	Input a "H" or "L" level signal or leave open.
P5_3, P5_4	Input port P5	I	Input a "H" or "L" level signal or leave open.
MODE	MODE	I/O	Input a "L" level signal.
P1_4	TXD output	O	Serial data output pin
P1_5	RXD input	I	Serial data input pin

I: Input O: Output I/O: Input and output

**Figure 28.17 Pin Handling in Standard Serial I/O Mode 2**

Table 28.9 Pin Functions (Flash Memory Standard Serial I/O Mode 3)

Pin	Name	I/O	Description
VCC, VSS	Power supply input		Apply the guaranteed programming and erasure voltage to the VCC pin and 0 V to the VSS pin.
RESET	Reset input	I	Reset input pin
P4_6/XIN	P4_6 input/clock input	I	If an external oscillator is connected, connect a ceramic resonator or crystal oscillator between pins XIN and XOUT. To use as an input port, input a "H" or "L" level signal or leave the pin open.
P4_7/XOUT	P4_7 input/clock output	I/O	
P0_0 to P0_7	Input port P0	I	Input a "H" or "L" level signal or leave open.
P1_0 to P1_7	Input port P1	I	Input a "H" or "L" level signal or leave open.
P3_1, P3_3 to P3_7	Input port P3	I	Input a "H" or "L" level signal or leave open.
P4_2/VREF, P4_5	Input port P4	I	Input a "H" or "L" level signal or leave open.
P5_3, P5_4	Input port P5	I	Input a "H" or "L" level signal or leave open.
MODE	MODE	I/O	Serial data I/O pin. Connect the pin to a programmer.

I: Input O: Output I/O: Input and output

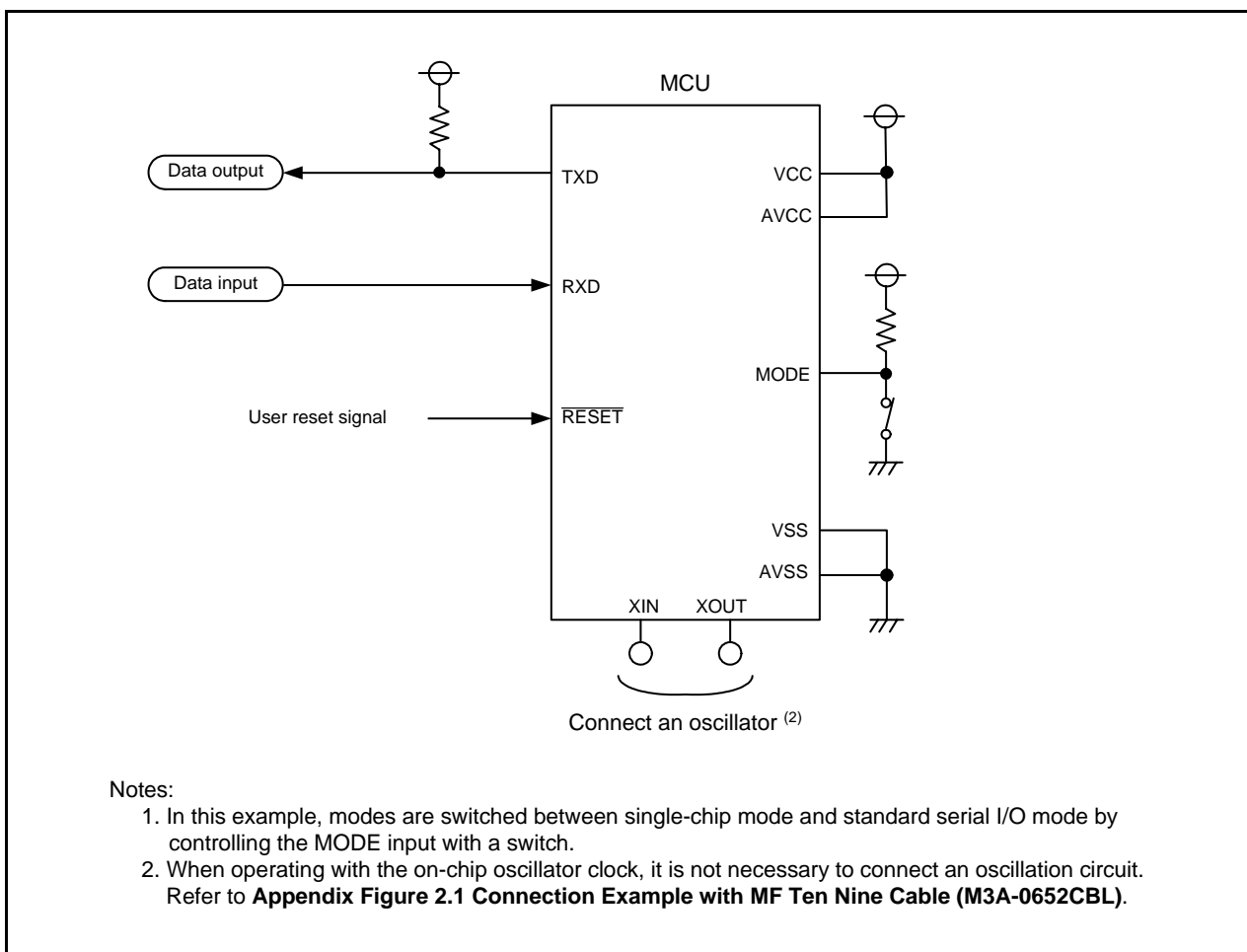
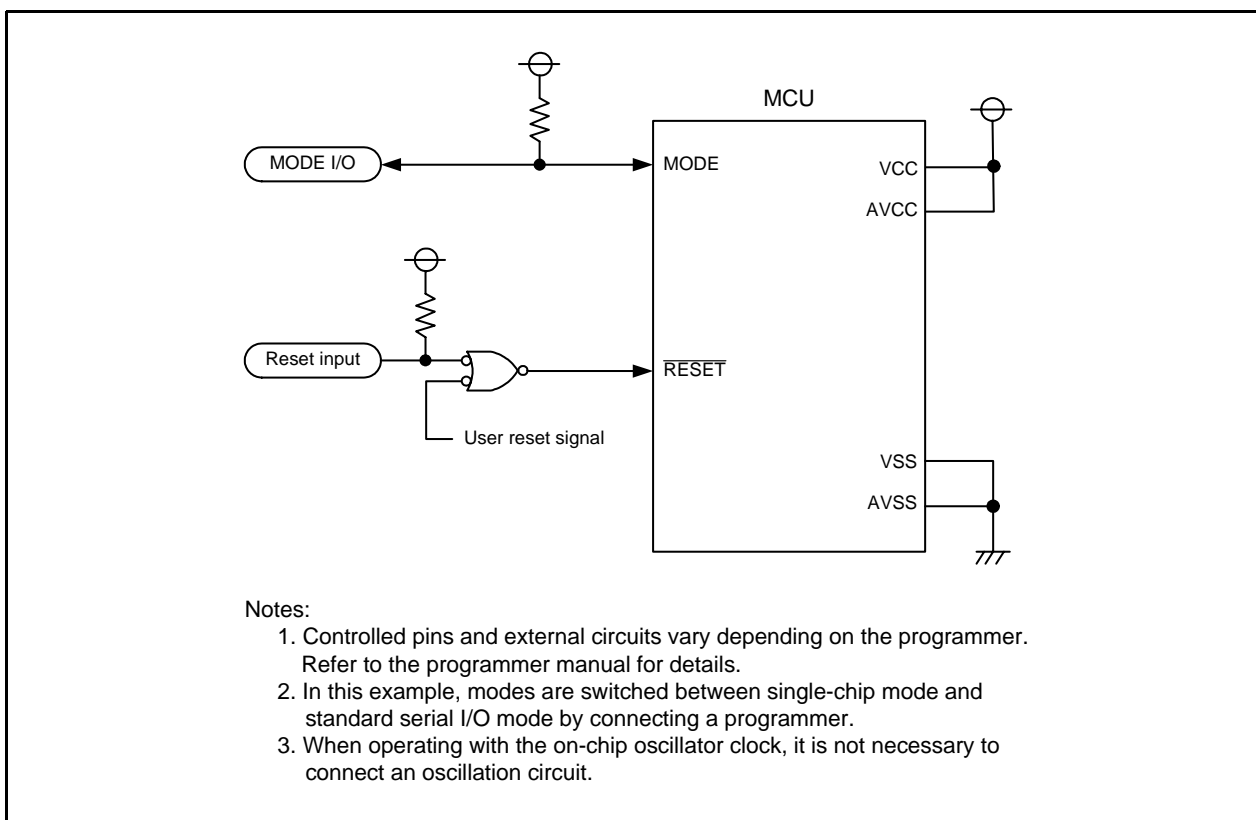

Figure 28.18 Pin Handling in Standard Serial I/O Mode 3

28.6 Parallel I/O Mode

Parallel I/O mode is used to input and output software commands, addresses and data necessary to control (read, program, and erase) the on-chip flash memory.

Use a parallel programmer which supports the MCU. Contact the parallel programmer manufacturer for more information. Refer to the user's manual included with your parallel programmer for instructions.

In parallel I/O mode, the user ROM areas shown in Figure 28.1 can be rewritten.

28.6.1 ROM Code Protect Function

The ROM code protect function prevents the flash memory from being read and rewritten. (Refer to the **28.3.2 ROM Code Protect Function**.)

28.7 Notes on Flash Memory

28.7.1 CPU Rewrite Mode

28.7.1.1 Prohibited Instructions

The following instructions cannot be used while the program ROM area is being rewritten in EW0 mode because they reference data in the flash memory: UND, INTO, and BRK.

28.7.1.2 Interrupts

Tables 28.10 to 28.12 show CPU Rewrite Mode Interrupts (1), (2) and (3), respectively.

Table 28.10 CPU Rewrite Mode Interrupts (1)

Mode	Erase/Write Target	Status	Maskable Interrupt
EW0	Data flash (1)	During auto-erase (suspend enabled)	When an interrupt request is acknowledged, interrupt handling is executed. If the FMR22 bit is set to 1 (erase-suspend request enabled by interrupt request), the FMR21 bit is automatically set to 1 (erase-suspend request). The flash memory suspends auto-erase after td(SR-SUS). If erase-suspend is required while the FMR22 bit is set to 0 (erase-suspend request disabled by interrupt request), set the FMR21 bit to 1 during interrupt handling. The flash memory suspends auto-erase after td(SR-SUS). While auto-erase is being suspended, any block other than the block during auto-erase execution can be read or written. Auto-erase can be restarted by setting the FMR21 bit to 0 (erase restart).
		During auto-erase (suspend disabled or FMR22 = 0)	Interrupt handling is executed while auto-erase or auto-programming is being performed.
		During auto-programming	
	Program ROM	During auto-erase (suspend enabled)	Usable by allocating a vector in RAM.
		During auto-erase (suspend disabled)	
		During auto-programming	
EW1	Data flash (1)	During auto-erase (suspend enabled)	When an interrupt request is acknowledged, interrupt handling is executed. If the FMR22 bit is set to 1, the FMR21 bit is automatically set to 1. The flash memory suspends auto-erase after td(SR-SUS). If erase-suspend is required while the FMR22 bit is set to 0, set the FMR21 bit to 1 during interrupt handling. The flash memory suspends auto-erase after td(SR-SUS). While auto-erase is being suspended, any block other than the block during auto-erase execution can be read or written. Auto-erase can be restarted by setting the FMR21 bit to 0.
		During auto-erase (suspend disabled or FMR22 = 0)	Interrupt handling is executed while auto-erase or auto-programming is being performed.
		During auto-programming	
	Program ROM	During auto-erase (suspend enabled)	Auto-erase suspends after td(SR-SUS) and interrupt handling is executed. Auto-erase can be restarted by setting the FMR21 bit to 0 after interrupt handling completes. While auto-erase is being suspended, any block other than the block during auto-erase execution can be read or written.
		During auto-erase (suspend disabled or FMR22 = 0)	Auto-erase and auto-programming have priority and interrupt requests are put on standby. Interrupt handling is executed after auto-erase and auto-program complete.
		During auto-programming	

FMR21, FMR22: Bits in FMR2 register

Note:

1. The R8C/33G Group Group has data flash.

Table 28.11 CPU Rewrite Mode Interrupts (2)

Mode	Erase/ Write Target	Status	<ul style="list-style-type: none"> • Watchdog Timer • Oscillation Stop Detection • Voltage Monitor 2 • Voltage Monitor 1 (Note 1)	<ul style="list-style-type: none"> • Undefined Instruction • INTO Instruction • BRK Instruction • Single Step • Address Match • Address Break (Note 1)
EW0	Data flash	During auto-erasure (suspend enabled) ⁽²⁾	When an interrupt request is acknowledged, interrupt handling is executed. If the FMR22 bit is set to 1 (erase-suspend request enabled by interrupt request), the FMR21 bit is automatically set to 1 (erase-suspend request). The flash memory suspends auto-erasure after td(SR-SUS). If erase-suspend is required while the FMR22 bit is set to 0 (erase-suspend request disabled by interrupt request), set the FMR21 bit to 1 during interrupt handling. The flash memory suspends auto-erasure after td(SR-SUS). While auto-erasure is being suspended, any block other than the block during auto-erasure execution can be read or written. Auto-erasure can be restarted by setting the FMR21 bit is set to 0 (erase restart).	When an interrupt request is acknowledged, interrupt handling is executed. If erase-suspend is required, set the FMR21 bit to 1 during interrupt handling. The flash memory suspends auto-erasure after td(SR-SUS). While auto-erasure is being suspended, any block other than the block during auto-erasure execution can be read or written. Auto-erasure can be restarted by setting the FMR21 bit in the FMR2 register is set to 0 (erase restart).
		During auto-erasure (suspend disabled or FMR22 = 0)	Interrupt handling is executed while auto-erasure or auto-programming is being performed.	
	During auto-programming			
	Program ROM	During auto-erasure (suspend enabled)	When an interrupt request is acknowledged, auto-erasure or auto-programming is forcibly stopped immediately and the flash memory is reset. Interrupt handling starts when the flash memory restarts after the fixed period. Since the block during auto-erasure or the address during auto-programming is forcibly stopped, the normal value may not be read. After the flash memory restarts, execute auto-erasure again and ensure it completes normally. The watchdog timer does not stop during the command operation, so interrupt requests may be generated. Initialize the watchdog timer regularly using the erase-suspend function.	Not usable during auto-erasure or auto-programming.
	During auto-erasure (suspend disabled)			
	During auto-programming			

FMR21, FMR22: Bits in FMR2 register

Notes:

1. Do not use a non-maskable interrupt while block 0 is being auto-erased because the fixed vector is allocated in block 0.
2. The R8C/33G Group has data flash.

Table 28.12 CPU Rewrite Mode Interrupts (3)

Mode	Erase/ Write Target	Status	<ul style="list-style-type: none"> • Watchdog Timer • Oscillation Stop Detection • Voltage Monitor 2 • Voltage Monitor 1 <p style="text-align: right;">(Note 1)</p>	<ul style="list-style-type: none"> • Undefined Instruction • INTO Instruction • BRK Instruction • Single Step • Address Match • Address Break <p style="text-align: right;">(Note 1)</p>
EW1	Data flash	During auto-erasure (suspend enabled) ⁽²⁾	When an interrupt request is acknowledged, interrupt handling is executed. If the FMR22 bit is set to 1, the FMR21 bit is automatically set to 1. The flash memory suspends auto-erasure after td(SR-SUS). If erase-suspend is required while the FMR22 bit is set to 0, set the FMR21 bit to 1 during interrupt handling. The flash memory suspends auto-programming after td(SR-SUS). While auto-erasure is being suspended, any block other than the block during auto-erasure execution can be read or written. Auto-erasure can be restarted by setting the FMR21 bit is set to 0.	When an interrupt request is acknowledged, interrupt handling is executed. If erase-suspend is required, set the FMR21 bit to 1 during interrupt handling. The flash memory suspends auto-erasure after td(SR-SUS). While auto-erasure is being suspended, any block other than the block during auto-erasure execution can be read or written. Auto-erasure can be restarted by setting the FMR21 bit in the FMR2 register is set to 0 (erase restart).
		During auto-erasure (suspend disabled or FMR22 = 0)	Interrupt handling is executed while auto-erasure or auto-programming is being performed.	
		During auto-programming		
	Program ROM	During auto-erasure (suspend enabled)	When an interrupt request is acknowledged, auto-erasure or auto-programming is forcibly stopped immediately and the flash memory is reset. Interrupt handling starts when the flash memory restarts after the fixed period.	Not usable during auto-erasure or auto-programming.
		During auto-erasure (suspend disabled or FMR22 = 0)	Since the block during auto-erasure or the address during auto-programming is forcibly stopped, the normal value may not be read. After the flash memory restarts, execute auto-erasure again and ensure it completes normally.	
		During auto-programming	The watchdog timer does not stop during the command operation, so interrupt requests may be generated. Initialize the watchdog timer regularly using the erase-suspend function.	

FMR21, FMR22: Bits in FMR2 register

Notes:

1. Do not use a non-maskable interrupt while block 0 is being auto-erased because the fixed vector is allocated in block 0.
2. The R8C/33G Group has data flash.

28.7.1.3 How to Access

To set one of the following bits to 1, first write 0 and then 1 immediately. Disable interrupts and DTC activation between writing 0 and writing 1.

- The FMR01 bit or FMR02 bit in the FMR0 register
- The FMR13 bit in the FMR1 register
- The FMR20 bit, FMR22 bit, or FMR 27 bit in the FMR2 register

To set one of the following bits to 0, first write 1 and then 0 immediately. Disable interrupts and DTC activation between writing 1 and writing 0.

- The FMR14 bit, FMR15 bit, FMR16 bit, or FMR17 bit in the FMR1 register

28.7.1.4 Rewriting User ROM Area

In EW0 mode, if the supply voltage drops while rewriting any block in which a rewrite control program is stored, it may not be possible to rewrite the flash memory because the rewrite control program cannot be rewritten correctly. In this case, use standard serial I/O mode.

28.7.1.5 Programming

Do not write additions to the already programmed address.

28.7.1.6 Entering Stop Mode or Wait Mode

Do not enter stop mode or wait mode during erase-suspend.

If the FST7 bit in the FST register is set to 0 (busy (during programming or erasure execution)), do not enter to stop mode or wait mode.

Do not enter stop mode or wait mode while the FMR27 bit is 1 (low-current-consumption read mode enabled).

28.7.1.7 Note when data flash is used

To use data flash with more than 16 MHz CPU clock, set the FMR23 bit in the FMR2 register to 1 (4 cycles of the CPU clock).

28.7.1.8 Low-Current-Consumption Read Mode

In low-speed clock mode and low-speed on-chip oscillator mode, the current consumption when reading the flash memory can be reduced by setting the FMR27 bit in the FMR2 register to 1 (low-current-consumption read mode enabled).

When the CPU clock is set to the low-speed on-chip oscillator clock divided by 4, 8, or 16, low-current-consumption read mode can be used. When divided by 1 (no division) or divided by 2 is set, do not use low-current-consumption read mode.

After setting the divide ratio of the CPU clock, set the FMR27 bit to 1 (low-current-consumption read mode enabled).

To reduce the power consumption, refer to **29. Reducing Power Consumption**.

Enter wait mode or stop mode after setting the FMR27 bit to 0 (low-current-consumption read mode disabled).

Do not enter wait mode or stop mode while the FMR27 bit is 1 (low-current-consumption read mode enabled).

29. Reducing Power Consumption

29.1 Overview

This chapter describes key points and processing methods for reducing power consumption.

29.2 Key Points and Processing Methods for Reducing Power Consumption

Key points for reducing power consumption are shown below. They should be referred to when designing a system or creating a program.

29.2.1 Voltage Detection Circuit

If voltage monitor 1 is not used, set the VCA26 bit in the VCA2 register to 0 (voltage detection 1 circuit disabled). If voltage monitor 2 is not used, set the VCA27 bit in the VCA2 register to 0 (voltage detection 2 circuit disabled).

If the power-on reset and voltage monitor 0 reset are not used, set the VCA25 bit in the VCA2 register to 0 (voltage detection 0 circuit disabled).

29.2.2 Ports

Even after the MCU enters wait mode or stop mode, the states of the I/O ports are retained. Current flows into the output ports in the active state, and shoot-through current flows into the input ports in the high-impedance state. Unnecessary ports should be set to input and fixed to a stable electric potential before the MCU enters wait mode or stop mode.

29.2.3 Clocks

Power consumption generally depends on the number of the operating clocks and their frequencies. The fewer the number of operating clocks or the lower their frequencies, the more power consumption decreases. Unnecessary clocks should be stopped accordingly.

Stopping low-speed on-chip oscillator oscillation: Set the CM14 bit in the CM1 register to 1 (low-speed on-chip oscillator off) and the OCD2 bit in the OCD register to 0 (XIN clock selected).

Stopping high-speed on-chip oscillator oscillation: Set the FRA00 bit in the FRA0 register to 0.

29.2.4 Wait Mode, Stop Mode

Power consumption can be reduced in wait mode and stop mode. Refer to **9.6 Power Control** for details.

29.2.5 Stopping Peripheral Function Clocks

If the peripheral function f1, f2, f4, f8, and f32 clocks are not necessary in wait mode, set the CM02 bit in the CM0 register to 1 (peripheral function clock stops in wait mode). This will stop the f1, f2, f4, f8, and f32 clocks in wait mode.

29.2.6 Timers

If timer RA is not used, set the TCKCUT bit in the TRAMR register to 1 (count source cutoff).

If timer RB is not used, set the TCKCUT bit in the TRBMR register to 1 (count source cutoff).

If timer RC is not used, set the MSTTRC bit in the MSTCR register to 1 (standby).

If timer RD is not used, set bits TCK2 to TCK0 in the TRDCR_i (i = 0 to 1) register to 000b (f1) and the MSTTRD bit in the MSTCR register to 1 (standby).

29.2.7 A/D Converter

When the A/D converter is not used, power consumption can be reduced by setting the ADSTBY bit in the ADCON1 register to 0 (A/D operation stops (standby)) to shut off any analog circuit current flow.

29.2.8 Clock Synchronous Serial Interface

When the SSU is not used, set the MSTIIC bit in the MSTCR register to 1 (standby).

29.2.9 Reducing Internal Power Consumption Using VCA20 Bit

The electric current in wait mode can be further reduced by setting the VCA20 bit in the VCA2 register to 1 (low consumption enabled). Set the VCA20 bit to 1 in low-speed clock mode or low-speed on-chip oscillator mode before entering wait mode.

The setting procedure for reducing internal power consumption using the VCA20 bit differs when the CM30 bit in the CM3 register is set to 1 (MCU enters wait mode) to enter wait mode and when the WAIT instruction is executed to enter wait mode. Figure 29.1 shows the Setting Procedure for Reducing Internal Power Consumption Using VCA20 Bit when CM30 Bit in CM3 Register is Set to 1 (MCU Enters Wait Mode) to Enter Wait Mode. Figure 29.2 shows the Setting Procedure for Reducing Internal Power Consumption Using VCA20 Bit when WAIT Instruction is Executed to Enter Wait Mode.

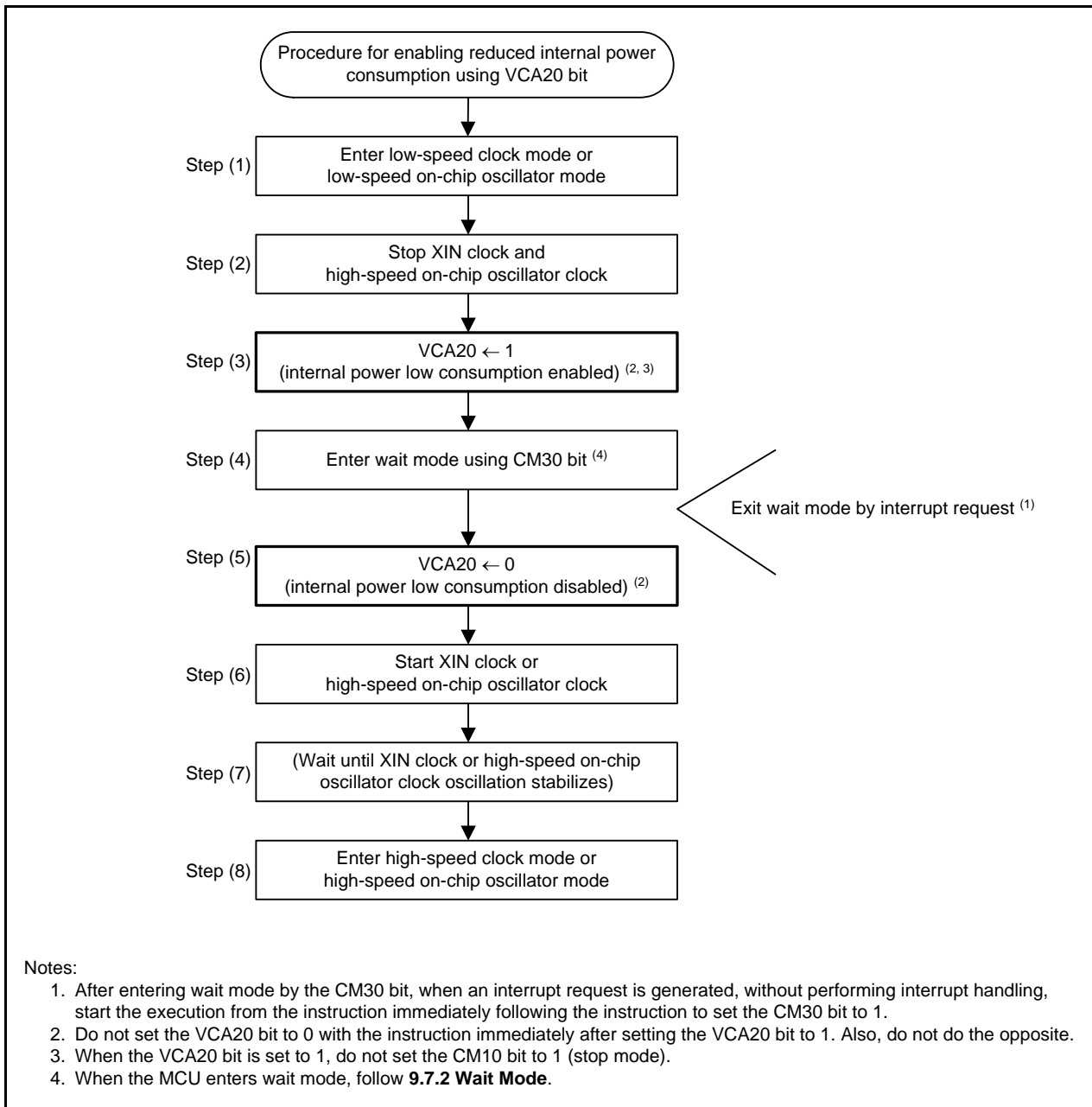

Figure 29.1 Setting Procedure for Reducing Internal Power Consumption Using VCA20 Bit when CM30 Bit in CM3 Register is Set to 1 (MCU Enters Wait Mode) to Enter Wait Mode

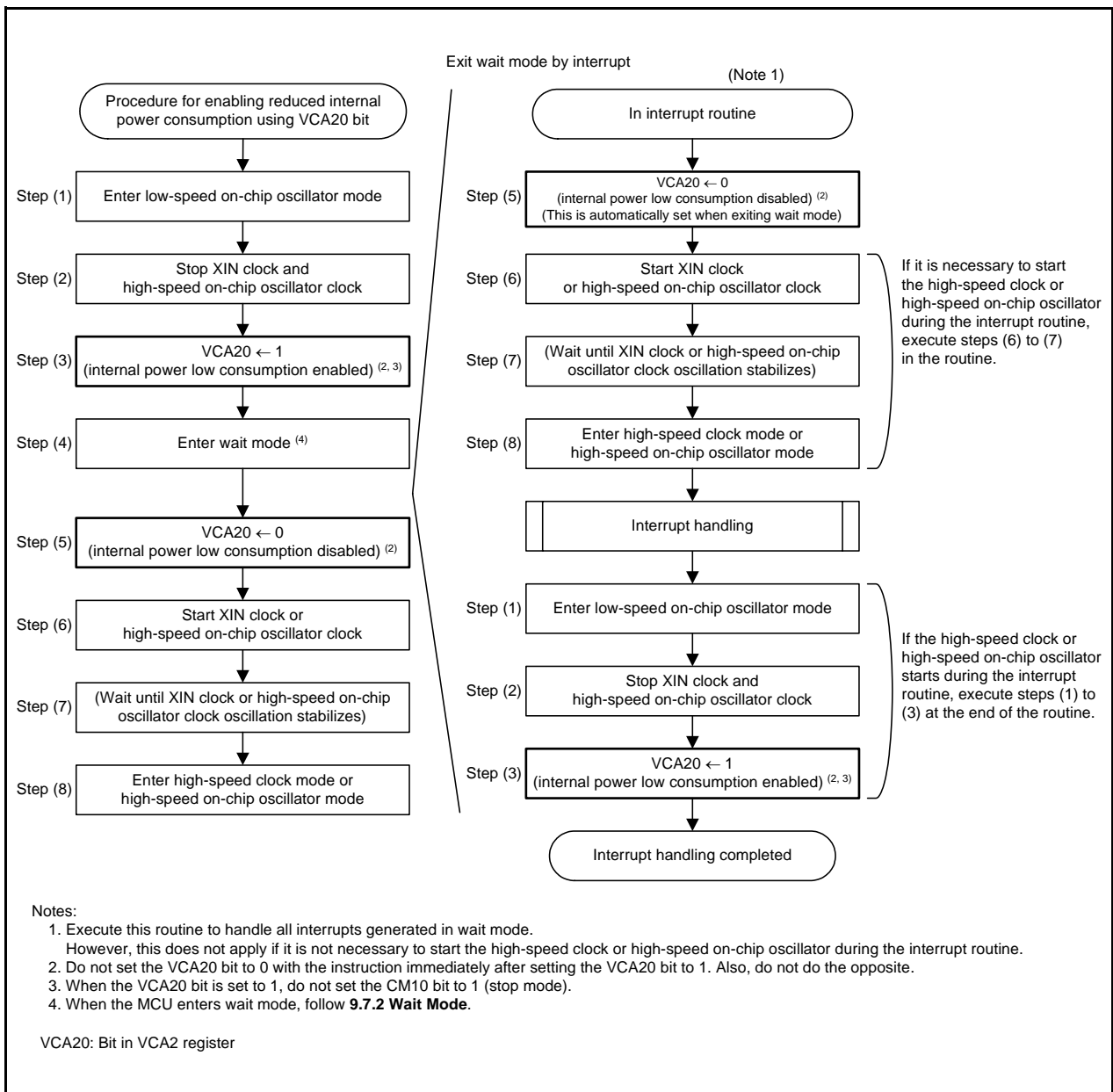

Figure 29.2 Setting Procedure for Reducing Internal Power Consumption Using VCA20 Bit when WAIT Instruction is Executed to Enter Wait Mode

29.2.10 Stopping Flash Memory

In low-speed on-chip oscillator mode, power consumption can be further reduced by stopping the flash memory using the FMSTP bit in the FMR0 register.

Access to the flash memory is disabled by setting the FMSTP bit to 1 (flash memory stops). The FMSTP bit must be written to by a program transferred to RAM.

When the MCU enters stop mode or wait mode while CPU rewrite mode is disabled, the power for the flash memory is automatically turned off. It is turned back on again after the MCU exits stop mode or wait mode. This eliminates the need to set the FMR0 register.

Figure 29.3 shows the Handling Procedure Example for Reducing Power Consumption Using FMSTP Bit.

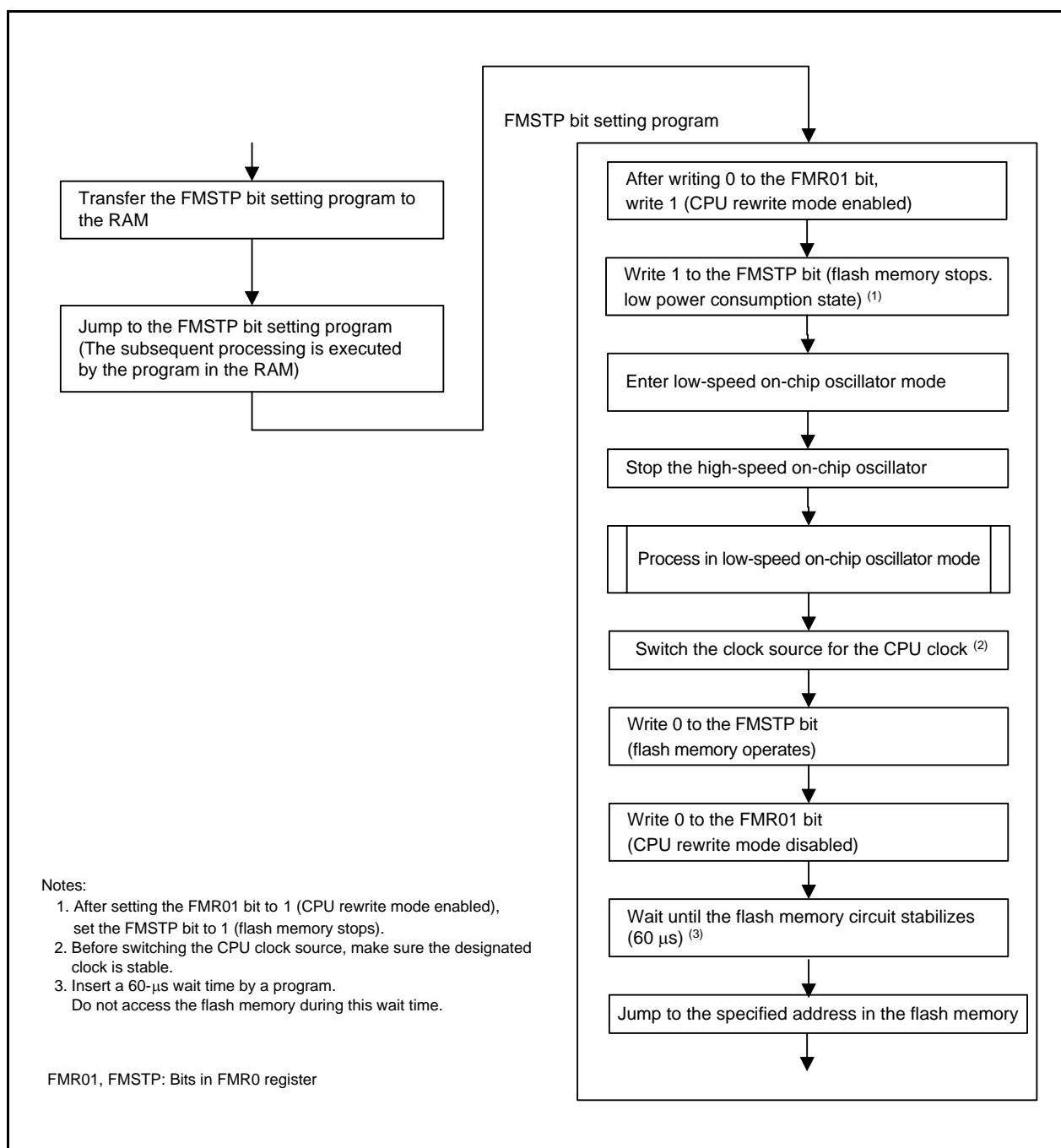

Figure 29.3 Handling Procedure Example for Reducing Power Consumption Using FMSTP Bit

29.2.11 Low-Current-Consumption Read Mode

In low-speed on-chip oscillator mode, the current consumption when reading the flash memory can be reduced by setting the FMR27 bit in the FMR2 register to 1 (low-current-consumption read mode enabled).

When the CPU clock is set to the low-speed on-chip oscillator clock divided by 4, 8, or 16, low-current-consumption read mode can be used. When divided by 1 (no division) or divided by 2 is set, do not use low-current-consumption read mode.

After setting the divide ratio of the CPU clock, set the FMR27 bit to 1 (low-current-consumption read mode enabled).

Enter wait mode or stop mode after setting the FMR27 bit to 0 (low-current-consumption read mode disabled).

Do not enter wait mode or stop mode while the FMR27 bit is 1 (low-current-consumption read mode enabled).

Figure 29.4 shows the Handling Procedure Example of Low-Current-Consumption Read Mode.

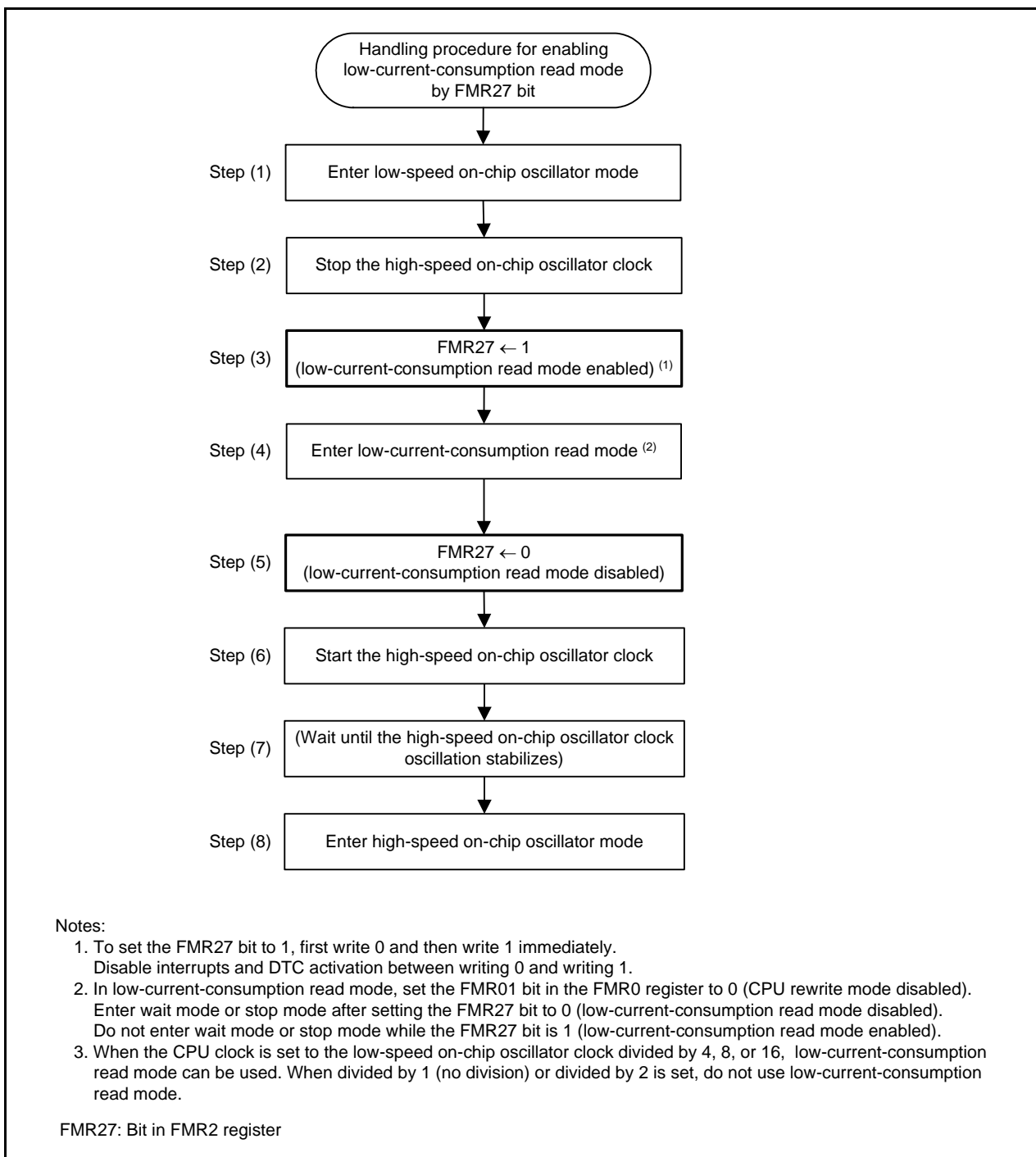

Figure 29.4 Handling Procedure Example of Low-Current-Consumption Read Mode

30. Electrical Characteristics

Table 30.1 Absolute Maximum Ratings

Symbol	Parameter	Condition	Rated Value	Unit
V _{CC} /AV _{CC}	Supply voltage		-0.3 to 6.5	V
V _I	Input voltage (1)		-0.3 to V _{CC} + 0.3	V
I _{IN}	Input current (1)	(2, 3, 4)	-4 to 4	mA
V _O	Output voltage		-0.3 to V _{CC} + 0.3	V
P _d	Power dissipation	-40°C ≤ T _{opr} ≤ 85°C	300	mW
		85°C < T _{opr} ≤ 125°C	125	mW
T _{opr}	Operating ambient temperature		-40 to 85 (J version) / -40 to 125 (K version)	°C
T _{stg}	Storage temperature		-65 to 150	°C

Notes:

1. Meet the specified range for the input voltage or the input current.
2. Applicable ports: P0, P1, P3_1, P3_3 to P3_7, P4_5, P5_3, P5_4
3. The total input current must be 12 mA or less.
4. Even if no voltage is supplied to V_{CC}, the input current may cause the MCU to be powered on and operate. When a voltage is supplied to V_{CC}, the input current may cause the supply voltage to rise. Since operations in any cases other than above are not guaranteed, use the power supply circuit in the system to ensure the supply voltage for the MCU is stable within the specified range.

Table 30.2 Recommended Operating Conditions

Symbol	Parameter			Conditions	Standard			Unit	
					Min.	Typ.	Max.		
V _{CC} /AV _{CC}	Supply voltage				2.7	–	5.5	V	
V _{SS} /AV _{SS}	Supply voltage				–	0	–	V	
V _{IH}	Input “H” voltage	Other than CMOS input				0.8 V _{CC}	–	V _{CC}	V
		CMOS input	Input level switching function (I/O port)	Input level selection : 0.35 V _{CC}	4.0 V ≤ V _{CC} ≤ 5.5 V	0.5 V _{CC}	–	V _{CC}	V
					2.7 V ≤ V _{CC} < 4.0 V	0.55 V _{CC}	–	V _{CC}	V
				Input level selection : 0.5 V _{CC}	4.0 V ≤ V _{CC} ≤ 5.5 V	0.65 V _{CC}	–	V _{CC}	V
					2.7 V ≤ V _{CC} < 4.0 V	0.7 V _{CC}	–	V _{CC}	V
				Input level selection : 0.7 V _{CC}	4.0 V ≤ V _{CC} ≤ 5.5 V	0.85 V _{CC}	–	V _{CC}	V
					2.7 V ≤ V _{CC} < 4.0 V	0.85 V _{CC}	–	V _{CC}	V
		External clock input (XOUT)				1.2	–	V _{CC}	V
V _{IL}	Input “L” voltage	Other than CMOS input				0	–	0.2 V _{CC}	V
		CMOS input	Input level switching function (I/O port)	Input level selection : 0.35 V _{CC}	4.0 V ≤ V _{CC} ≤ 5.5 V	0	–	0.2 V _{CC}	V
					2.7 V ≤ V _{CC} < 4.0 V	0	–	0.2 V _{CC}	V
				Input level selection : 0.5 V _{CC}	4.0 V ≤ V _{CC} ≤ 5.5 V	0	–	0.4 V _{CC}	V
					2.7 V ≤ V _{CC} < 4.0 V	0	–	0.3 V _{CC}	V
				Input level selection : 0.7 V _{CC}	4.0 V ≤ V _{CC} ≤ 5.5 V	0	–	0.55 V _{CC}	V
					2.7 V ≤ V _{CC} < 4.0 V	0	–	0.45 V _{CC}	V
		External clock input (XOUT)				0	–	0.4	V
I _{OH(sum)}	Peak sum output “H” current	Sum of all pins I _{OH(peak)}			–	–	–80	mA	
I _{OH(sum)}	Average sum output “H” current	Sum of all pins I _{OH(avg)}			–	–	–40	mA	
I _{OH(peak)}	Peak output “H” current				–	–	–10	mA	
I _{OH(avg)}	Average output “H” current				–	–	–5	mA	
I _{OL(sum)}	Peak sum output “L” current	Sum of all pins I _{OL(peak)}			–	–	80	mA	
I _{OL(sum)}	Average sum output “L” current	Sum of all pins I _{OL(avg)}			–	–	40	mA	
I _{OL(peak)}	Peak output “L” current				–	–	10	mA	
I _{OL(avg)}	Average output “L” current				–	–	5	mA	
f _(XIN)	XIN clock input oscillation frequency			2.7 V ≤ V _{CC} ≤ 5.5 V	–	–	20	MHz	
f _{OCO40M}	When used as the count source for timer RC or timer RD ⁽³⁾			2.7 V ≤ V _{CC} ≤ 5.5 V	32	–	40	MHz	
f _{OCO-F}	f _{OCO-F} frequency			2.7 V ≤ V _{CC} ≤ 5.5 V	–	–	20	MHz	
–	System clock frequency			2.7 V ≤ V _{CC} ≤ 5.5 V	–	–	20	MHz	
f _(BCLK)	CPU clock frequency			2.7 V ≤ V _{CC} ≤ 5.5 V	–	–	20	MHz	

Notes:

1. V_{CC} = 2.7 to 5.5 V and T_{opr} = –40 to 85°C (J version) / –40 to 125°C (K version), unless otherwise specified.
2. The average output current indicates the average value of current measured during 100 ms.
3. f_{OCO40M} can be used as the count source for timer RC or timer RD in the range of V_{CC} = 2.7 V to 5.5V.

Table 30.3 Recommended Operating Conditions (2)

Symbol	Parameter		Conditions	Standard			Unit
				Min.	Typ.	Max.	
I _{IC(H)}	High input injection current	P0, P1, P3_1, P3_3 to P3_7, P4_5, P5_3, P5_4	V _I > V _{CC}	–	–	2	mA
I _{IC(L)}	Low input injection current	P0, P1, P3_1, P3_3 to P3_7, P4_5, P5_3, P5_4	V _I < V _{SS}	–	–	–2	mA
Σ I _{IC}	Total injection current			–	–	8	mA

Note:

- V_{CC} = 4.5 to 5.5 V and T_{opr} = –40 to 85°C (J version) / –40 to 125°C (K version), unless otherwise specified.

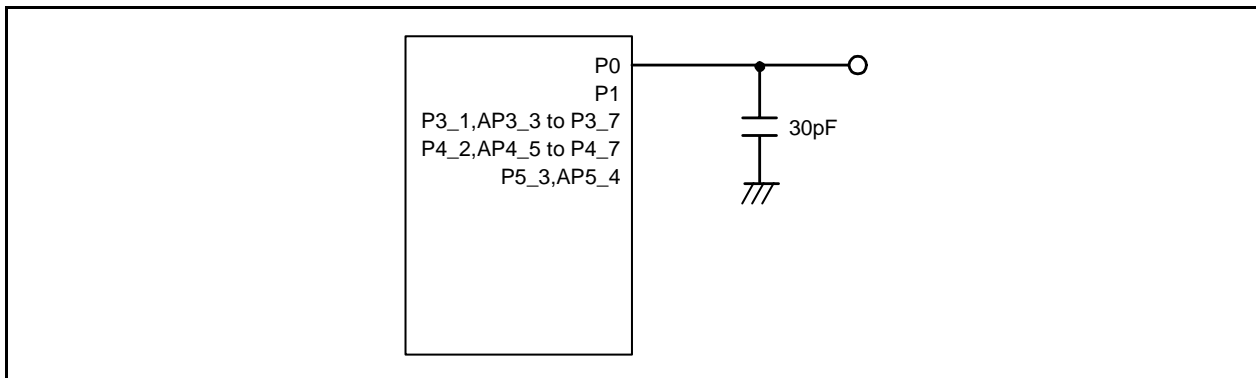

Figure 30.1 Ports P0 to P1, P3_1, P3_3 to P3_7, P4_2, P4_5 to P4_7, P5_3, and P5_4 Timing Measurement Circuit

Table 30.4 A/D Converter Characteristics

Symbol	Parameter		Conditions	Standard			Unit
				Min.	Typ.	Max.	
–	Resolution		$V_{ref} = AV_{CC}$	–	–	10	Bit
–	Absolute accuracy	10-bit mode	$V_{ref} = AV_{CC} = 5.0\text{ V}$ AN0 to AN7 input, AN8 to AN11 input	–	–	± 3	LSB
			$V_{ref} = AV_{CC} = 3.0\text{ V}$ AN0 to AN7 input, AN8 to AN11 input	–	–	± 5	LSB
		8-bit mode	$V_{ref} = AV_{CC} = 5.0\text{ V}$ AN0 to AN7 input, AN8 to AN11 input	–	–	± 2	LSB
			$V_{ref} = AV_{CC} = 3.0\text{ V}$ AN0 to AN7 input, AN8 to AN11 input	–	–	± 2	LSB
ϕ_{AD}	A/D conversion clock		$4.0\text{ V} \leq V_{ref} = AV_{CC} \leq 5.5\text{ V}$ (2)	2	–	20	MHz
			$2.7\text{ V} \leq V_{ref} = AV_{CC} \leq 5.5\text{ V}$ (2)	2	–	10	MHz
–	Tolerance level impedance			–	3	–	$k\Omega$
tCONV	Conversion time	10-bit mode	$V_{ref} = AV_{CC} = 5.0\text{ V}$, $\phi_{AD} = 20\text{ MHz}$	2.2	–	–	μs
		8-bit mode	$V_{ref} = AV_{CC} = 5.0\text{ V}$, $\phi_{AD} = 20\text{ MHz}$	2.2	–	–	μs
tsAMP	Sampling time		$\phi_{AD} = 20\text{ MHz}$	0.80	–	–	μs
I _{Vref}	V _{ref} current (4)		$V_{CC} = 5\text{ V}$, XIN = f1 = $\phi_{AD} = 20\text{ MHz}$	–	45	–	μA
V _{ref}	Reference voltage			2.7	–	AV _{CC}	V
V _{IA}	Analog input voltage (3)			0	–	V _{ref}	V
OCVREF	On-chip reference voltage		$2\text{ MHz} \leq \phi_{AD} \leq 4\text{ MHz}$	1.14	1.34	1.54	V

Notes:

1. $V_{CC}/AV_{CC} = V_{ref} = 2.7$ to 5.5 V , $V_{SS} = 0\text{ V}$ and $T_{opr} = -40$ to 85°C (J version) / -40 to 125°C (K version), unless otherwise specified.
2. The A/D conversion result will be undefined in wait mode, stop mode, when the flash memory stops, and in low-current-consumption mode. Do not perform A/D conversion in these states or transition to these states during A/D conversion.
3. When the analog input voltage is over the reference voltage, the A/D conversion result will be 3FFh in 10-bit mode and FFh in 8-bit mode.
4. When the D/A converter unused.

Table 30.5 D/A Converter Characteristics

Symbol	Parameter	Condition	Standard			Unit
			Min.	Typ.	Max.	
–	Resolution		–	–	8	Bit
–	Absolute accuracy		–	–	2.5	LSB
t_{su}	Setup time		–	–	3	μs
R_o	Output resistor		–	6	–	$k\Omega$
I_{Vref}	Reference power input current	(Note 2)	–	–	1.5	mA

Notes:

- $V_{CC}/AV_{CC} = V_{ref} = 2.7$ to 5.5 V and $T_{opr} = -40$ to $85^\circ C$ (J version) / -40 to $125^\circ C$ (K version), unless otherwise specified.
- This applies when one D/A converter is used and the value of the DA_i register ($i = 0$ or 1) for the unused D/A converter is 00h. The resistor ladder of the A/D converter is not included.

Table 30.6 Comparator B Electrical Characteristics

Symbol	Parameter	Condition	Standard			Unit
			Min.	Typ.	Max.	
V_{ref}	$IVREF1$, $IVREF3$ input reference voltage		0	–	$V_{CC} - 1.4$	V
V_i	$IVCMP1$, $IVCMP3$ input voltage		-0.3	–	$V_{CC} + 0.3$	V
–	Offset		–	5	100	mV
t_d	Comparator output delay time ⁽²⁾	$V_i = V_{ref} \pm 100$ mV	–	0.1	–	μs
I_{CMP}	Comparator operating current	$V_{CC} = 5.0$ V	–	17.5	–	μA

Notes:

- $V_{CC} = 2.7$ to 5.5 V, $T_{opr} = -40$ to $85^\circ C$ (J version) / -40 to $125^\circ C$ (K version), unless otherwise specified.
- When the digital filter is disabled.

Table 30.7 Flash Memory (Program ROM) Electrical Characteristics

Symbol	Parameter	Conditions	Standard			Unit
			Min.	Typ.	Max.	
–	Program/erase endurance ⁽²⁾	R8C/33G Group	1,000 ⁽³⁾	–	–	times
		R8C/33H Group	100 ⁽³⁾	–	–	times
–	Byte program time (program/erase endurance ≤ 100 times)		–	80	300	μs
–	Byte program time (program/erase endurance > 100 times)		–	80	500	μs
–	Block erase time		–	0.3	4	s
t _d (SR-SUS)	Time delay from suspend request until suspend		–	–	5+CPU clock × 3 cycles	ms
–	Interval from erase start/restart until following suspend request		0	–	–	μs
–	Time from suspend until erase restart		–	–	30+CPU clock × 1 cycle	μs
t _d (CMDRST-READY)	Time from when command is forcibly terminated until reading is enabled		–	–	30+CPU clock × 1 cycle	μs
–	Program, erase voltage		2.7	–	5.5	V
–	Read voltage		2.7	–	5.5	V
–	Program, erase temperature		–40	–	85°C (J version), 125°C (K version)	°C
–	Data hold time ⁽⁷⁾	Ambient temperature = 55°C ⁽⁸⁾	20	–	–	year

Notes:

- VCC = 2.7 to 5.5 V and Topr = -40 to 85°C (J version) / -40 to 125°C (K version), unless otherwise specified.
- Definition of programming/erasure endurance
The programming and erasure endurance is defined on a per-block basis.
If the programming and erasure endurance is n (n = 10,000), each block can be erased n times. For example, if 1,024 1-byte writes are performed to different addresses in block A, a 1 Kbyte block, and then the block is erased, the programming/erasure endurance still stands at one.
However, the same address must not be programmed more than once per erase operation (overwriting prohibited).
- Endurance to guarantee all electrical characteristics after program and erase. (1 to Min. value can be guaranteed).
- In a system that executes multiple programming operations, the actual erasure count can be reduced by writing to sequential addresses in turn so that as much of the block as possible is used up before performing an erase operation. For example, when programming groups of 16 bytes, the effective number of rewrites can be minimized by programming up to 128 groups before erasing them all in one operation. It is also advisable to retain data on the erasure endurance of each block and limit the number of erase operations to a certain number.
- If an error occurs during block erase, attempt to execute the clear status register command, then execute the block erase command at least three times until the erase error does not occur.
- Customers desiring program/erase failure rate information should contact their Renesas technical support representative.
- The data hold time includes time that the power supply is off or the clock is not supplied.
- This data hold time includes 3,000 hours in Ta = 125°C and 7,000 hours in Ta = 85°C.

Table 30.8 Flash Memory (Data flash Block A to Block D) Electrical Characteristics

Symbol	Parameter	Conditions	Standard			Unit
			Min.	Typ.	Max.	
–	Program/erase endurance ⁽²⁾		10,000 ⁽³⁾	–	–	times
–	Byte program time (program/erase endurance ≤ 1,000 times)		–	160	950	μs
–	Byte program time (program/erase endurance > 1,000 times)		–	300	950	μs
–	Block erase time (program/erase endurance ≤ 1,000 times)		–	0.2	1	s
–	Block erase time (program/erase endurance > 1,000 times)		–	0.3	1	s
t _{d(SR-SUS)}	Time delay from suspend request until suspend		–	–	3+CPU clock × 3 cycles	ms
–	Interval from erase start/restart until following suspend request		0	–	–	μs
–	Time from suspend until erase restart		–	–	30+CPU clock × 1 cycle	μs
t _{d(CMDRST-READY)}	Time from when command is forcibly terminated until reading is enabled		–	–	30+CPU clock × 1 cycle	μs
–	Program, erase voltage		2.7	–	5.5	V
–	Read voltage		2.7	–	5.5	V
–	Program, erase temperature		–40	–	85°C (J version), 125°C (K version)	°C
–	Data hold time ⁽⁷⁾	Ambient temperature = 55 °C ⁽⁸⁾	20	–	–	year

Notes:

- V_{CC} = 2.7 to 5.5 V and T_{opr} = –40 to 85°C (J version) / –40 to 125°C (K version), unless otherwise specified.
- Definition of programming/erasure endurance
The programming and erasure endurance is defined on a per-block basis.
If the programming and erasure endurance is n (n = 10,000), each block can be erased n times. For example, if 1,024 1-byte writes are performed to different addresses in block A, a 1 Kbyte block, and then the block is erased, the programming/erasure endurance still stands at one.
However, the same address must not be programmed more than once per erase operation (overwriting prohibited).
- Endurance to guarantee all electrical characteristics after program and erase. (1 to Min. value can be guaranteed).
- In a system that executes multiple programming operations, the actual erasure count can be reduced by writing to sequential addresses in turn so that as much of the block as possible is used up before performing an erase operation. For example, when programming groups of 16 bytes, the effective number of rewrites can be minimized by programming up to 128 groups before erasing them all in one operation. In addition, averaging the erasure endurance between blocks A to D can further reduce the actual erasure endurance. It is also advisable to retain data on the erasure endurance of each block and limit the number of erase operations to a certain number.
- If an error occurs during block erase, attempt to execute the clear status register command, then execute the block erase command at least three times until the erase error does not occur.
- Customers desiring program/erase failure rate information should contact their Renesas technical support representative.
- The data hold time includes time that the power supply is off or the clock is not supplied.
- This data hold time includes 3,000 hours in T_a = 125°C and 7,000 hours in T_a = 85°C.

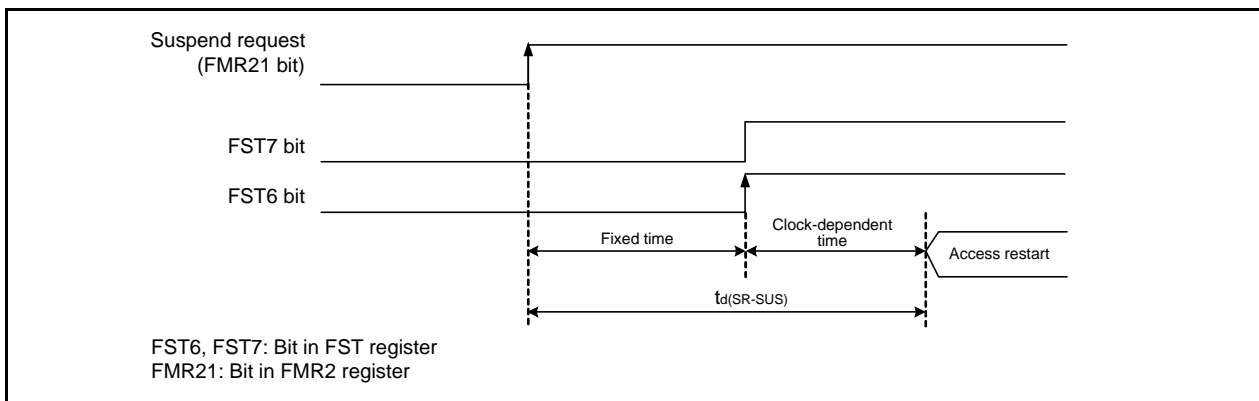

Figure 30.2 Time delay until Suspend

Table 30.9 Voltage Detection 0 Circuit Electrical Characteristics

Symbol	Parameter	Condition	Standard			Unit
			Min.	Typ.	Max.	
V _{det0}	Voltage detection level	At the falling of V _{CC}	2.70	2.85	3.05	V
–	Voltage detection 0 circuit response time ⁽³⁾	At the falling of V _{CC} from 5 V to (V _{det0} – 0.1) V	–	6	150	μs
–	Voltage detection circuit self power consumption	VCA25 = 1, V _{CC} = 5.0 V	–	1.5	–	μA
t _{d(E-A)}	Waiting time until voltage detection circuit operation starts ⁽²⁾		–	–	100	μs

Notes:

1. The measurement condition is V_{CC} = 2.7 V to 5.5 V and T_{opr} = –40 to 85°C (J version) / –40 to 125°C (K version).
2. Necessary time until the voltage detection circuit operates when setting to 1 again after setting the VCA25 bit in the VCA2 register to 0.
3. Time until the voltage monitor 0 reset is generated after the voltage passes V_{det0}.

Table 30.10 Voltage Detection 1 Circuit Electrical Characteristics

Symbol	Parameter	Condition	Standard			Unit
			Min.	Typ.	Max.	
V _{det1}	Voltage detection level V _{det1_7} ⁽²⁾	At the falling of V _{CC}	2.95	3.25	3.55	V
	Voltage detection level V _{det1_8} ⁽²⁾	At the falling of V _{CC}	3.10	3.40	3.70	V
	Voltage detection level V _{det1_9} ⁽²⁾	At the falling of V _{CC}	3.25	3.55	3.85	V
	Voltage detection level V _{det1_A} ⁽²⁾	At the falling of V _{CC}	3.40	3.70	4.00	V
	Voltage detection level V _{det1_B} ⁽²⁾	At the falling of V _{CC}	3.55	3.85	4.15	V
	Voltage detection level V _{det1_C} ⁽²⁾	At the falling of V _{CC}	3.70	4.00	4.30	V
	Voltage detection level V _{det1_D} ⁽²⁾	At the falling of V _{CC}	3.85	4.15	4.45	V
	Voltage detection level V _{det1_E} ⁽²⁾	At the falling of V _{CC}	4.00	4.30	4.60	V
–	Hysteresis width at the rising of V _{CC} in voltage detection 1 circuit		–	0.10	–	V
–	Voltage detection 1 circuit response time ⁽³⁾	At the falling of V _{CC} from 5 V to (V _{det1_7} – 0.1) V	–	60	150	μs
–	Voltage detection circuit self power consumption	VCA26 = 1, V _{CC} = 5.0 V	–	1.7	–	μA
t _{d(E-A)}	Waiting time until voltage detection circuit operation starts ⁽⁴⁾		–	–	100	μs

Notes:

1. The measurement condition is V_{CC} = 2.7 V to 5.5 V and T_{opr} = –40 to 85°C (J version) / –40 to 125°C (K version).
2. Select the voltage detection level with bits VD1S0 to VD1S3 in the VD1LS register.
3. Time until the voltage monitor 1 interrupt request is generated after the voltage passes V_{det1}.
4. Necessary time until the voltage detection circuit operates when setting to 1 again after setting the VCA26 bit in the VCA2 register to 0.

Table 30.11 Voltage Detection 2 Circuit Electrical Characteristics

Symbol	Parameter	Condition	Standard			Unit
			Min.	Typ.	Max.	
V _{det2}	Voltage detection level V _{det2}	At the falling of V _{cc}	3.70	4.00	4.30	V
–	Hysteresis width at the rising of V _{cc} in voltage detection 2 circuit		–	0.10	–	V
–	Voltage detection 2 circuit response time ⁽²⁾	At the falling of V _{cc} from 5 V to (V _{det2} – 0.1) V	–	20	150	μs
–	Voltage detection circuit self power consumption	VCA27 = 1, V _{cc} = 5.0 V	–	1.7	–	μA
t _{d(E-A)}	Waiting time until voltage detection circuit operation starts ⁽³⁾		–	–	100	μs

Notes:

1. The measurement condition is V_{cc} = 2.7 V to 5.5 V and T_{opr} = –40 to 85°C (J version) / –40 to 125°C (K version).
2. Time until the voltage monitor 2 interrupt request is generated after the voltage passes V_{det2}.
3. Necessary time until the voltage detection circuit operates after setting to 1 again after setting the VCA27 bit in the VCA2 register to 0.

Table 30.12 Power-on Reset Circuit (2)

Symbol	Parameter	Condition	Standard			Unit
			Min.	Typ.	Max.	
t _{rth}	External power V _{cc} rise gradient	⁽¹⁾	0	–	50,000	mV/msec

Notes:

1. The measurement condition is T_{opr} = –40 to 85°C (J version) / –40 to 125°C (K version), unless otherwise specified.
2. To use the power-on reset function, enable voltage monitor 0 reset by setting the LVDAS bit in the OFS register to 0.

**Figure 30.3 Power-on Reset Circuit Electrical Characteristics**

Table 30.13 High-speed On-Chip Oscillator Circuit Electrical Characteristics

Symbol	Parameter	Condition	Standard			Unit
			Min.	Typ.	Max.	
–	High-speed on-chip oscillator frequency after reset	$V_{CC} = 2.7\text{ V to } 5.5\text{ V}$, $-40^{\circ}\text{C} \leq T_{opr} \leq 85^{\circ}\text{C}$ (J version) / $-40^{\circ}\text{C} \leq T_{opr} \leq 125^{\circ}\text{C}$ (K version)	–	40	–	MHz
	High-speed on-chip oscillator frequency when the FRA4 register correction value is written into the FRA1 register and the FRA5 register correction value into the FRA3 register ⁽³⁾		–	36.864	–	MHz
	High-speed on-chip oscillator frequency when the FRA6 register correction value is written into the FRA1 register and the FRA7 register correction value into the FRA3 register		–	32	–	MHz
	High-speed on-chip oscillator frequency temperature . supply voltage dependence ⁽²⁾		–5	–	5	%
–	Oscillation stability time		–	200	–	μs
–	Self power consumption at oscillation	$V_{CC} = 5.0\text{ V}$, $T_{opr} = 25^{\circ}\text{C}$	–	400	–	μA

Notes:

1. $V_{CC} = 2.7$ to 5.5 V , $T_{opr} = -40$ to 85°C (J version) / -40 to 125°C (K version), unless otherwise specified.
2. This indicates the precision error for the oscillation frequency of the high-speed on-chip oscillator.
3. This enables the setting errors of bit rates such as 9600 bps and 38400 bps to be 0% when the serial interface is used in UART mode.

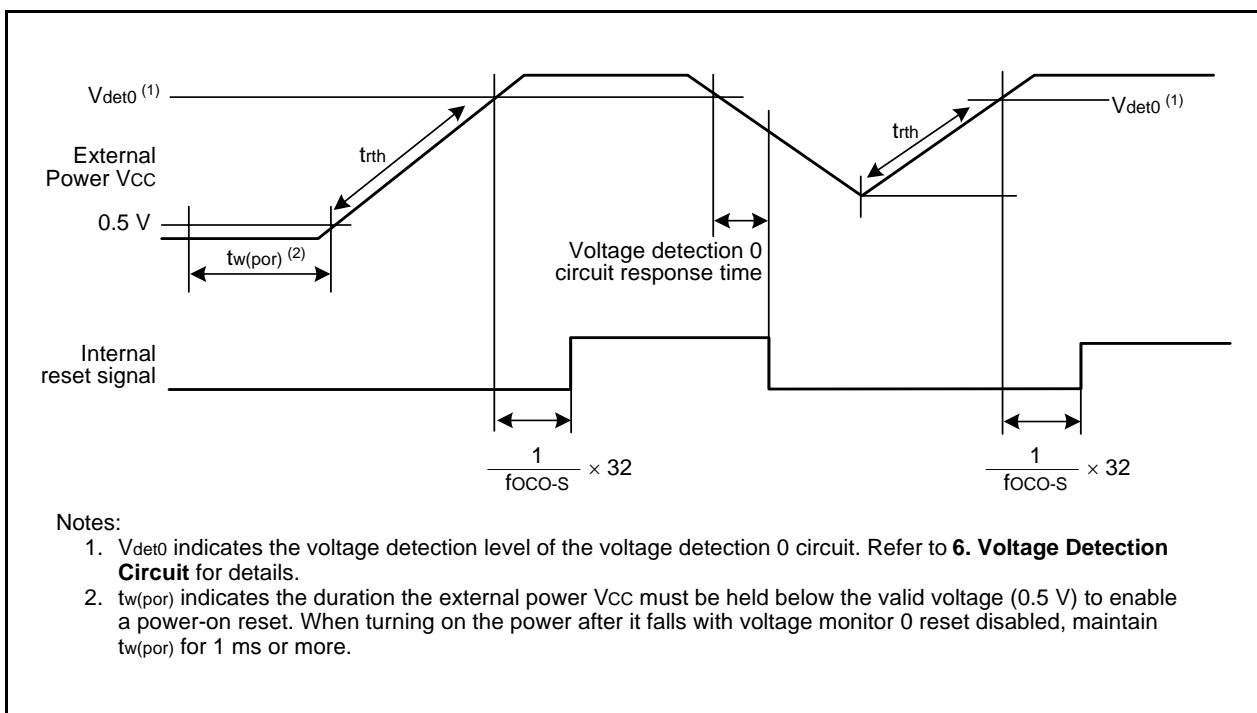
Table 30.14 Low-speed On-Chip Oscillator Circuit Electrical Characteristics

Symbol	Parameter	Condition	Standard			Unit
			Min.	Typ.	Max.	
fOCO-S	Low-speed on-chip oscillator frequency	$2.7\text{ V} \leq V_{CC} < 4.2\text{ V}$	106.25	125	143.75	kHz
		$4.2\text{ V} \leq V_{CC} \leq 5.5\text{ V}$	112.5	125	137.5	
fOCO-WDT	Low-speed on-chip oscillator frequency for watchdog timer	$2.7\text{ V} \leq V_{CC} < 4.2\text{ V}$	106.25	125	143.75	kHz
		$4.2\text{ V} \leq V_{CC} < 5.5\text{ V}$	112.5	125	137.5	
–	Oscillation stability time	$V_{CC} = 5.0\text{ V}$, $T_{opr} = 25^{\circ}\text{C}$	–	30	100	μs
–	Self power consumption at oscillation	$V_{CC} = 5.0\text{ V}$, $T_{opr} = 25^{\circ}\text{C}$	–	3	–	μA

Note:

1. $V_{CC} = 2.7$ to 5.5 V , $T_{opr} = -40$ to 85°C (J version) / -40 to 125°C (K version), unless otherwise specified.

Table 30.15 Power Supply Circuit Timing Characteristics

Symbol	Parameter	Condition	Standard			Unit
			Min.	Typ.	Max.	
$t_{d(P-R)}$	Time for internal power supply stabilization during power-on ⁽²⁾		–	–	2,000	μs

Notes:

1. The measurement condition is $V_{CC} = 2.7\text{ V to } 5.5\text{ V}$ and $T_{opr} = -40$ to 85°C (J version) / -40 to 125°C (K version).
2. Waiting time until the internal power supply generation circuit stabilizes during power-on.

Table 30.16 Timing Requirements of Synchronous Serial Communication Unit (SSU) (1)

Symbol	Parameter		Conditions	Standard			Unit
				Min.	Typ.	Max.	
tsucyc	SSCK clock cycle time			4	–	–	tcyc (2)
tHI	SSCK clock "H" width			0.4	–	0.6	tsucyc
tLO	SSCK clock "L" width			0.4	–	0.6	tsucyc
tRISE	SSCK clock rising time	Master		–	–	1	tcyc (2)
		Slave		–	–	1	μs
tFALL	SSCK clock falling time	Master		–	–	1	tcyc (2)
		Slave		–	–	1	μs
tsu	SSO, SSI data input setup time			100	–	–	ns
tH	SSO, SSI data input hold time			1	–	–	tcyc (2)
tLEAD	$\overline{\text{SCS}}$ setup time	Slave		1tcyc + 50	–	–	ns
tLAG	$\overline{\text{SCS}}$ hold time	Slave		1tcyc + 50	–	–	ns
tOD	SSO, SSI data output delay time			–	–	1	tcyc (2)
tSA	SSI slave access time		$2.7 \text{ V} \leq V_{\text{CC}} \leq 5.5 \text{ V}$	–	–	1.5tcyc + 100	ns
tOR	SSI slave out open time		$2.7 \text{ V} \leq V_{\text{CC}} \leq 5.5 \text{ V}$	–	–	1.5tcyc + 100	ns

Notes:

1. $V_{\text{CC}} = 2.7$ to 5.5 V , $V_{\text{SS}} = 0 \text{ V}$ and $T_{\text{opr}} = -40$ to 85°C (J version) / -40 to 125°C (K version), unless otherwise specified.
2. $1\text{tcyc} = 1/f_1(\text{s})$

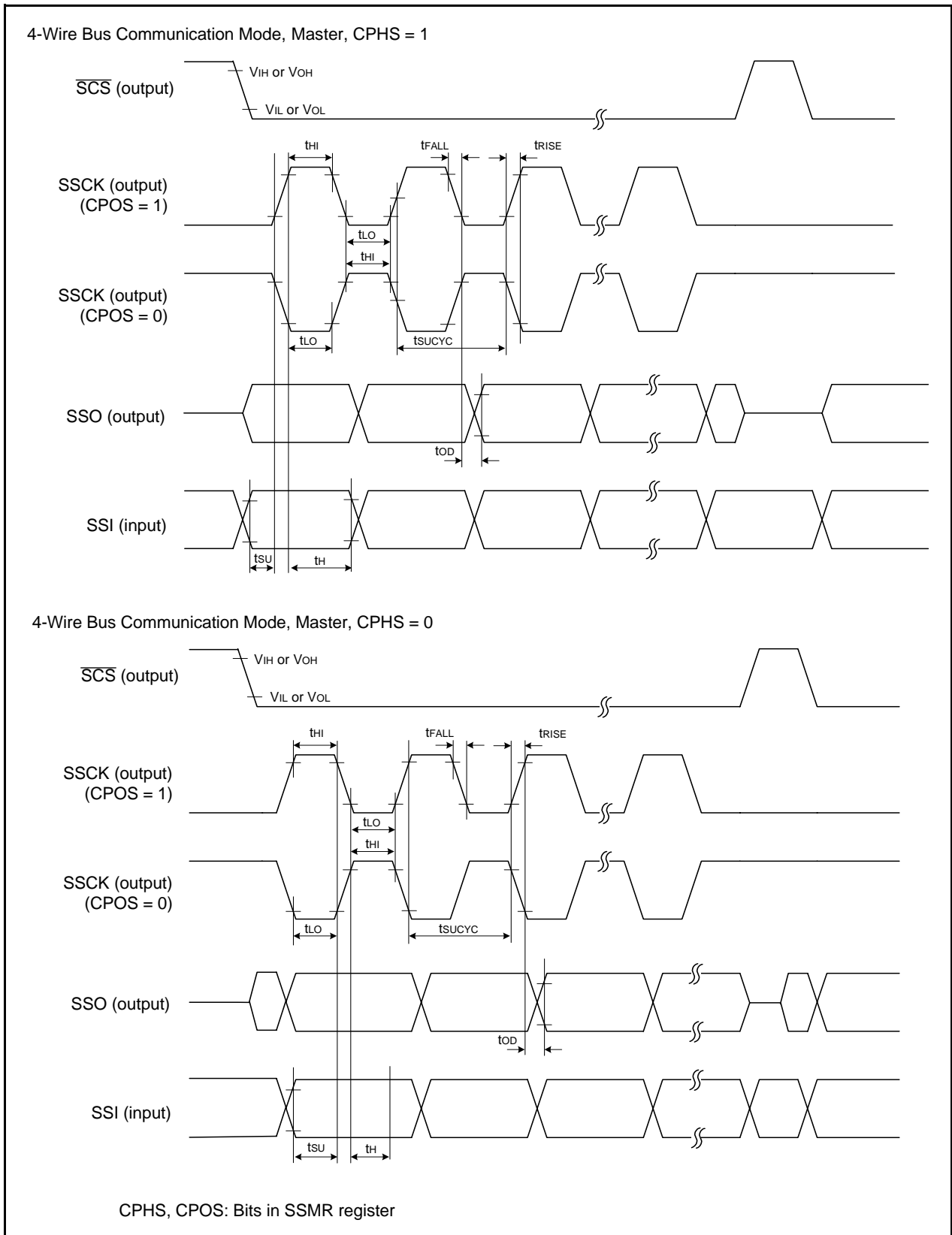

Figure 30.4 I/O Timing of Synchronous Serial Communication Unit (SSU) (Master)

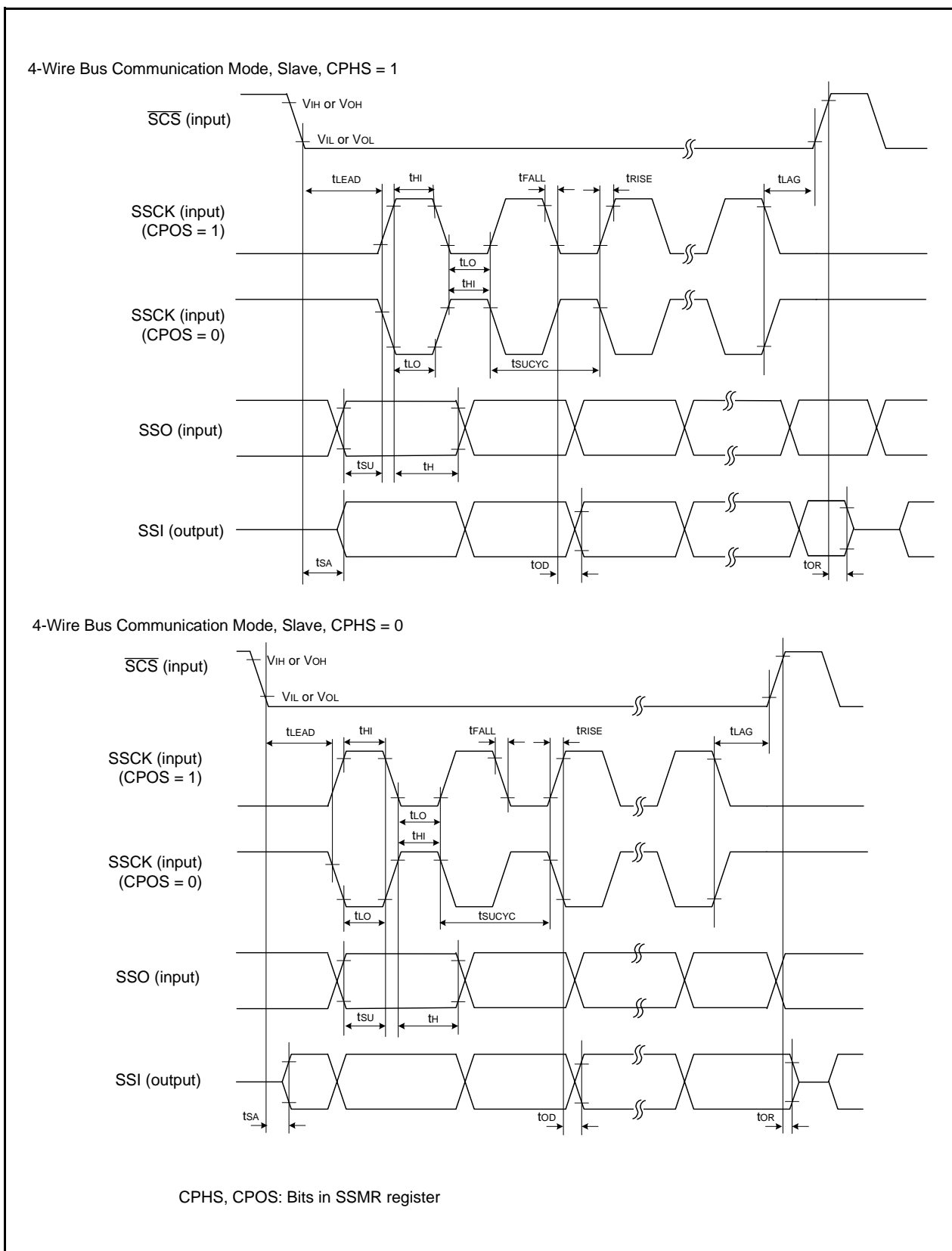

Figure 30.5 I/O Timing of Synchronous Serial Communication Unit (SSU) (Slave)

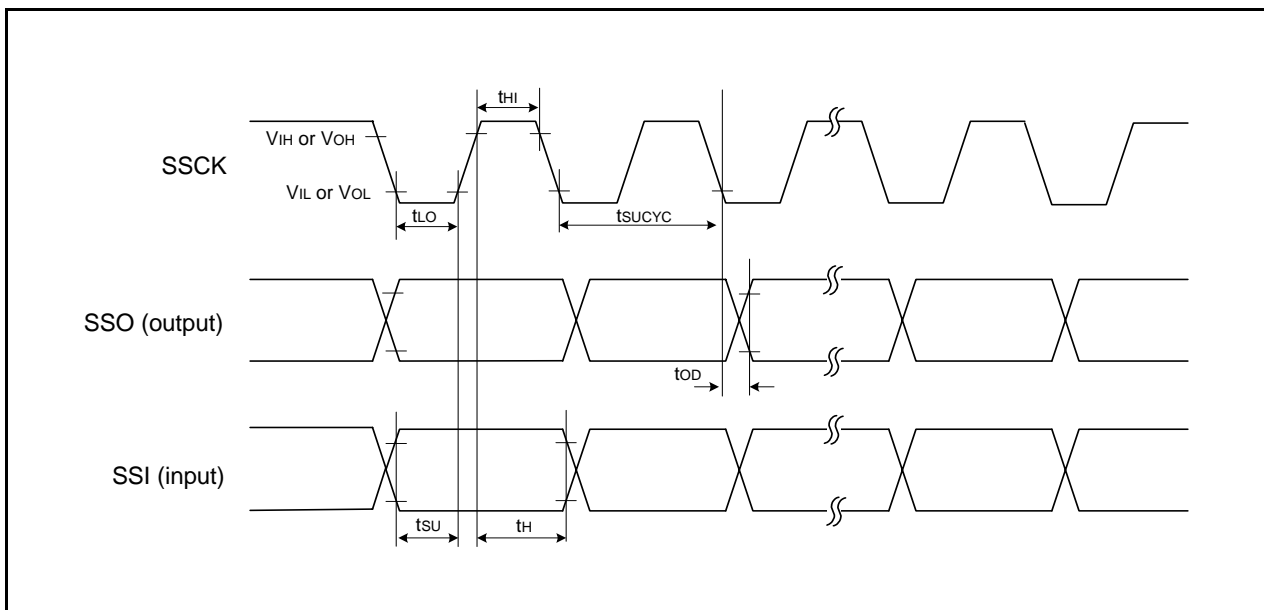

Figure 30.6 I/O Timing of Synchronous Serial Communication Unit (SSU) (Clock Synchronous Communication Mode)

Table 30.17 Electrical Characteristics (1) [4.2 V ≤ V_{CC} ≤ 5.5 V]

Symbol	Parameter		Condition	Standard			Unit
				Min.	Typ.	Max.	
V _{OH}	Output "H" voltage	Other than XOUT	I _{OH} = -5 mA	V _{CC} - 2.0	-	V _{CC}	V
			I _{OH} = -200 μA	V _{CC} - 0.3	-	V _{CC}	V
		XOUT	I _{OH} = -200 μA	1.0	-	V _{CC}	V
V _{OL}	Output "L" voltage	Other than XOUT	I _{OL} = 5 mA	-	-	2.0	V
			I _{OL} = 200 μA	-	-	0.45	V
		XOUT	I _{OL} = 200 μA	-	-	0.5	V
V _{T+} -V _{T-}	Hysteresis	INT0, INT1, INT3, KI0, KI1, KI2, KI3, TRAIO, TRBO, TRCIOA, TRCIOB, TRCIOC, TRCIOD, TRDIOA0, TRDIOB0, TRDIOC0, TRDIOD0, TRDIOA1, TRDIOB1, TRDIOC1, TRDIOD1, TRCTRG, TRCCLK, TRDCLK, ADTRG, RXD0, RXD2, CLK0, CLK2, SSI, SCL2, SDA2, SSO	V _{CC} = 5.0 V	0.1	1.2	-	V
		RESET	V _{CC} = 5.0 V	0.1	1.2	-	V
I _{IH}	Input "H" current		V _I = 5 V, V _{CC} = 5.0 V	-	-	1.0	μA
I _{IL}	Input "L" current		V _I = 0 V, V _{CC} = 5.0 V	-	-	-1.0	μA
R _{PULLUP}	Pull-up resistance		V _I = 0 V, V _{CC} = 5.0 V	25	50	100	kΩ
R _{fXIN}	Feedback resistance	XIN		-	0.3	-	MΩ
V _{RAM}	RAM hold voltage		During stop mode	2.0	-	-	V

Note:

- 4.2 V ≤ V_{CC} ≤ 5.5 V and T_{opr} = -40 to 85°C (J version) / -40 to 125°C (K version), f(XIN) = 20 MHz, unless otherwise specified.

Table 30.18 Electrical Characteristics (2) [3.3 V ≤ Vcc ≤ 5.5 V]
(Topr = −40 to 85°C (J version), unless otherwise specified.)

Symbol	Parameter	Condition	Standard			Unit	
			Min.	Typ.	Max.		
Icc	Power supply current (Vcc = 3.3 to 5.5 V) Single-chip mode, output pins are open, other pins are Vss	High-speed clock mode (1)	XIN = 20 MHz (square wave) High-speed on-chip oscillator off Low-speed on-chip oscillator on = 125 kHz No division	–	7.0	15	mA
			XIN = 16 MHz (square wave) High-speed on-chip oscillator off Low-speed on-chip oscillator on = 125 kHz No division	–	5.6	12.5	mA
			XIN = 10 MHz (square wave) High-speed on-chip oscillator off Low-speed on-chip oscillator on = 125 kHz No division	–	3.6	–	mA
			XIN = 20 MHz (square wave) High-speed on-chip oscillator off Low-speed on-chip oscillator on = 125 kHz Divide-by-8	–	3.0	–	mA
			XIN = 16 MHz (square wave) High-speed on-chip oscillator off Low-speed on-chip oscillator on = 125 kHz Divide-by-8	–	2.2	–	mA
			XIN = 10 MHz (square wave) High-speed on-chip oscillator off Low-speed on-chip oscillator on = 125 kHz Divide-by-8	–	1.5	–	mA
		High-speed on-chip oscillator mode (1)	XIN clock off High-speed on-chip oscillator on fOCO-F = 20 MHz Low-speed on-chip oscillator on = 125 kHz No division	–	7.0	15	mA
			XIN clock off High-speed on-chip oscillator on fOCO-F = 20 MHz Low-speed on-chip oscillator on = 125 kHz Divide-by-8	–	3.0	–	mA
		Low-speed on-chip oscillator mode	XIN clock off High-speed on-chip oscillator off Low-speed on-chip oscillator on = 125 kHz Divide-by-8, FMR27 = 1, VCA20 = 0	–	90	180	μA
		Wait mode	XIN clock off High-speed on-chip oscillator off Low-speed on-chip oscillator on = 125 kHz While a WAIT instruction is executed Peripheral clock operation VCA27 = VCA26 = VCA25 = 0 VCA20 = 1	–	15	110	μA
			XIN clock off High-speed on-chip oscillator off Low-speed on-chip oscillator on = 125 kHz While a WAIT instruction is executed Peripheral clock off VCA27 = VCA26 = VCA25 = 0 VCA20 = 1	–	5.0	100	μA
		Stop mode	XIN clock off, Topr = 25°C High-speed on-chip oscillator off Low-speed on-chip oscillator off CM10 = 1 Peripheral clock off VCA27 = VCA26 = VCA25 = 0	–	2.0	5.0	μA
			XIN clock off, Topr = 85°C High-speed on-chip oscillator off Low-speed on-chip oscillator off CM10 = 1 Peripheral clock off VCA27 = VCA26 = VCA25 = 0	–	15.0	–	μA

Note:

- The typical value (Typ.) indicates the current value when the CPU and the memory operate. The maximum value (Max.) indicates the current when the CPU, the memory, and the peripheral functions operate and the flash memory is programmed/erased.

Table 30.19 Electrical Characteristics (3) [3.3 V ≤ Vcc ≤ 5.5 V]
(Topr = −40 to 125°C (K version), unless otherwise specified.)

Symbol	Parameter	Condition	Standard			Unit	
			Min.	Typ.	Max.		
Icc	Power supply current (Vcc = 3.3 to 5.5 V) Single-chip mode, output pins are open, other pins are Vss	High-speed clock mode (1)	XIN = 20 MHz (square wave) High-speed on-chip oscillator off Low-speed on-chip oscillator on = 125 kHz No division	–	7.0	15	mA
			XIN = 16 MHz (square wave) High-speed on-chip oscillator off Low-speed on-chip oscillator on = 125 kHz No division	–	5.6	12.5	mA
			XIN = 10 MHz (square wave) High-speed on-chip oscillator off Low-speed on-chip oscillator on = 125 kHz No division	–	3.6	–	mA
			XIN = 20 MHz (square wave) High-speed on-chip oscillator off Low-speed on-chip oscillator on = 125 kHz Divide-by-8	–	3.0	–	mA
			XIN = 16 MHz (square wave) High-speed on-chip oscillator off Low-speed on-chip oscillator on = 125 kHz Divide-by-8	–	2.2	–	mA
			XIN = 10 MHz (square wave) High-speed on-chip oscillator off Low-speed on-chip oscillator on = 125 kHz Divide-by-8	–	1.5	–	mA
		High-speed on-chip oscillator mode (1)	XIN clock off High-speed on-chip oscillator on fOCO-F = 20 MHz Low-speed on-chip oscillator on = 125 kHz No division	–	7.0	15	mA
			XIN clock off High-speed on-chip oscillator on fOCO-F = 20 MHz Low-speed on-chip oscillator on = 125 kHz Divide-by-8	–	3.0	–	mA
		Low-speed on-chip oscillator mode	XIN clock off High-speed on-chip oscillator off Low-speed on-chip oscillator on = 125 kHz Divide-by-8, FMR27 = 1, VCA20 = 0	–	90	400	μA
		Wait mode	XIN clock off High-speed on-chip oscillator off Low-speed on-chip oscillator on = 125 kHz While a WAIT instruction is executed Peripheral clock operation VCA27 = VCA26 = VCA25 = 0 VCA20 = 1	–	15	330	μA
			XIN clock off High-speed on-chip oscillator off Low-speed on-chip oscillator on = 125 kHz While a WAIT instruction is executed Peripheral clock off VCA27 = VCA26 = VCA25 = 0 VCA20 = 1	–	5.0	320	μA
		Stop mode	XIN clock off, Topr = 25°C High-speed on-chip oscillator off Low-speed on-chip oscillator off CM10 = 1 Peripheral clock off VCA27 = VCA26 = VCA25 = 0	–	2.0	5.0	μA
			XIN clock off, Topr = 85°C High-speed on-chip oscillator off Low-speed on-chip oscillator off CM10 = 1 Peripheral clock off VCA27 = VCA26 = VCA25 = 0	–	60	–	μA

Note:

- The typical value (Typ.) indicates the current value when the CPU and the memory operate. The maximum value (Max.) indicates the current when the CPU, the memory, and the peripheral functions operate and the flash memory is programmed/erased.

Timing Requirements

(Unless Otherwise Specified: $V_{CC} = 5\text{ V}$, $V_{SS} = 0\text{ V}$ at $T_{opr} = -40^{\circ}\text{C}$ to 85°C (J version)/
 -40°C to 125°C (K version))

Table 30.20 External Clock Input (XOUT)

Symbol	Parameter	Standard		Unit
		Min.	Max.	
$t_{c(XOUT)}$	XOUT input cycle time	50	–	ns
$t_{WH(XOUT)}$	XOUT input "H" width	24	–	ns
$t_{WL(XOUT)}$	XOUT input "L" width	24	–	ns

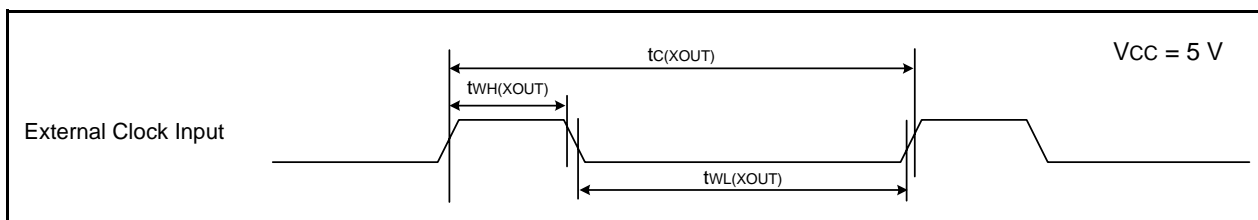
**Figure 30.7 External Clock Input Timing Diagram when $V_{CC} = 5\text{ V}$** **Table 30.21 TRAI0 Input**

Symbol	Parameter	Standard		Unit
		Min.	Max.	
$t_{c(TRAIO)}$	TRAIO input cycle time	100	–	ns
$t_{WH(TRAIO)}$	TRAIO input "H" width	40	–	ns
$t_{WL(TRAIO)}$	TRAIO input "L" width	40	–	ns

**Figure 30.8 TRAI0 Input Timing Diagram when $V_{CC} = 5\text{ V}$**

Table 30.22 Serial Interface

Symbol	Parameter	Condition	Standard		Unit
			Min.	Max.	
$t_{c(CK)}$	CLKi input cycle time	When external clock selected	200	–	ns
$t_{w(CKH)}$	CLKi input “H” width		100	–	ns
$t_{w(CKL)}$	CLKi input “L” width		100	–	ns
$t_{d(C-Q)}$	TXDi output delay time		–	90	ns
$t_{h(C-Q)}$	TXDi hold time		0	–	ns
$t_{su(D-C)}$	RXDi input setup time		10	–	ns
$t_{h(C-D)}$	RXDi input hold time		90	–	ns
$t_{d(C-Q)}$	TXDi output delay time	When internal clock selected	–	10	ns
$t_{su(D-C)}$	RXDi input setup time		90	–	ns
$t_{h(C-D)}$	RXDi input hold time		90	–	ns

$i = 0, 2$

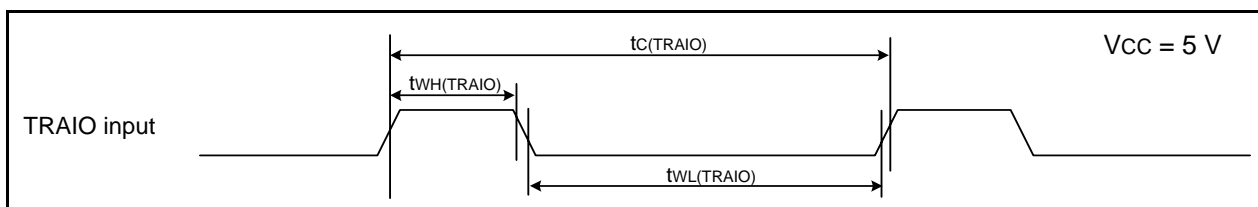
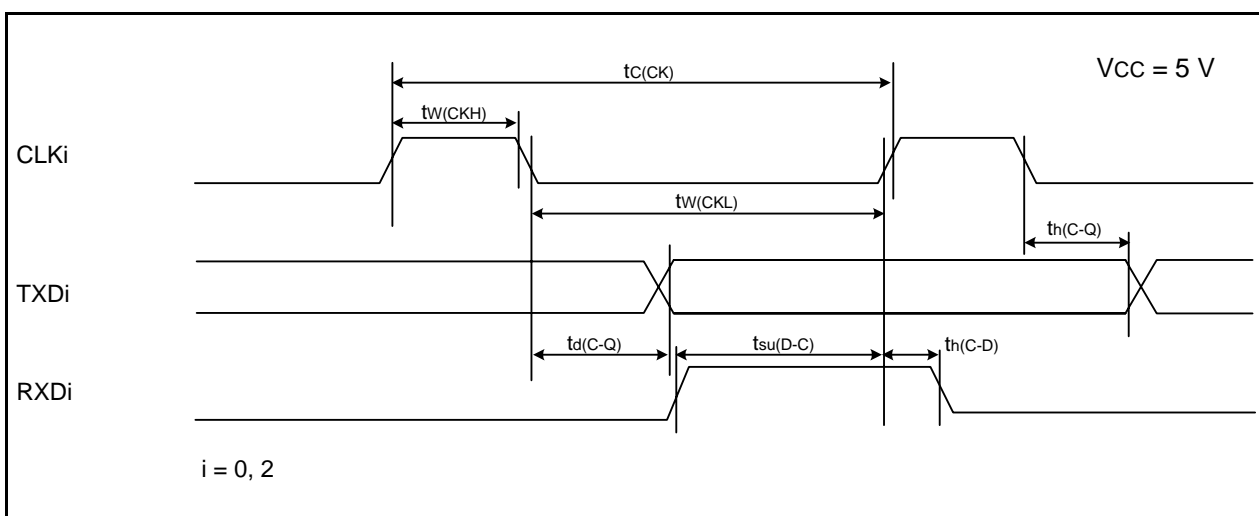

Figure 30.9 Serial Interface Timing Diagram when Vcc = 5 V

Table 30.23 External Interrupt \overline{INTi} ($i = 0$ to 1, 3) Input, Key Input Interrupt \overline{Kli} ($i = 0$ to 3)

Symbol	Parameter	Standard		Unit
		Min.	Max.	
$t_{w(INH)}$	\overline{INTi} input “H” width, \overline{Kli} input “H” width	250 (1)	–	ns
$t_{w(INL)}$	\overline{INTi} input “L” width, \overline{Kli} input “L” width	250 (2)	–	ns

Notes:

1. When selecting the digital filter by the \overline{INTi} input filter select bit, use an \overline{INTi} input HIGH width of either (1/digital filter clock frequency × 3) or the minimum value of standard, whichever is greater.
2. When selecting the digital filter by the \overline{INTi} input filter select bit, use an \overline{INTi} input LOW width of either (1/digital filter clock frequency × 3) or the minimum value of standard, whichever is greater.

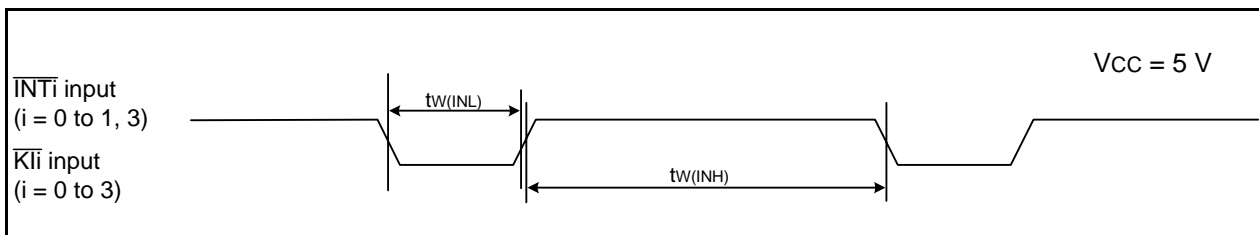

Figure 30.10 Input Timing Diagram for External Interrupt \overline{INTi} and Key Input Interrupt \overline{Kli} when Vcc = 5 V

Table 30.24 Electrical Characteristics (4) [$2.7\text{ V} \leq V_{CC} < 4.2\text{ V}$]

Symbol	Parameter		Condition	Standard			Unit
				Min.	Typ.	Max.	
V _{OH}	Output "H" voltage	Other than XOUT	I _{OH} = -1 mA	V _{CC} - 0.5	-	V _{CC}	V
		XOUT	I _{OH} = -200 μA	1.0	-	V _{CC}	V
V _{OL}	Output "L" voltage	Other than XOUT	I _{OL} = 1 mA	-	-	0.5	V
		XOUT	I _{OL} = 200 μA	-	-	0.5	V
V _{T+} -V _{T-}	Hysteresis	$\overline{\text{INT0}}, \overline{\text{INT1}}, \overline{\text{INT3}},$ K10, K11, K12, K13, TRAIO, TRBO, TRCIOA, TRCIOB, TRCIOC, TRCIOD, TRDIOA0, TRDIOB0, TRDIOC0, TRDIOD0, TRDIOA1, TRDIOB1, TRDIOC1, TRDIOD1, TRCTRG, TRCCLK, TRDCLK, ADTRG, RXD0, RXD2, CLK0, CLK2, SSI, SCL2, SDA2, SSO	V _{CC} = 3.0 V	0.1	0.4	-	V
		$\overline{\text{RESET}}$	V _{CC} = 3.0 V	0.1	0.5	-	V
I _{IH}	Input "H" current		V _I = 3 V, V _{CC} = 3.0 V	-	-	1.0	μA
I _{IL}	Input "L" current		V _I = 0 V, V _{CC} = 3.0 V	-	-	-1.0	μA
R _{PULLUP}	Pull-up resistance		V _I = 0 V, V _{CC} = 3.0 V	42	84	168	kΩ
R _{fXIN}	Feedback resistance	XIN		-	0.3	-	MΩ
V _{RAM}	RAM hold voltage		During stop mode	2.0	-	-	V

Note:

1. $2.7\text{ V} \leq V_{CC} < 4.2\text{ V}$ and T_{opr} = -40 to 85°C (J version) / -40 to 125°C (K version), f(XIN) = 20 MHz, unless otherwise specified.

Table 30.25 Electrical Characteristics (5) [2.7 V ≤ V_{CC} < 3.3 V]
(T_{opr} = -40 to 85°C (J version), unless otherwise specified.)

Symbol	Parameter	Condition	Standard			Unit	
			Min.	Typ.	Max.		
I _{CC}	Power supply current (2.7 V ≤ V _{CC} < 3.3 V) Single-chip mode, output pins are open, other pins are V _{SS}	High-speed clock mode (1)	XIN = 20 MHz (square wave) High-speed on-chip oscillator off Low-speed on-chip oscillator on = 125 kHz No division	–	7.0	14.5	mA
			XIN = 16 MHz (square wave) High-speed on-chip oscillator off Low-speed on-chip oscillator on = 125 kHz No division	–	5.6	12	mA
			XIN = 10 MHz (square wave) High-speed on-chip oscillator off Low-speed on-chip oscillator on = 125 kHz No division	–	3.6	–	mA
			XIN = 20 MHz (square wave) High-speed on-chip oscillator off Low-speed on-chip oscillator on = 125 kHz No division	–	3.0	–	mA
			XIN = 16 MHz (square wave) High-speed on-chip oscillator off Low-speed on-chip oscillator on = 125 kHz No division	–	2.2	–	mA
			XIN = 10 MHz (square wave) High-speed on-chip oscillator off Low-speed on-chip oscillator on = 125 kHz No division	–	1.5	–	mA
			High-speed on-chip oscillator mode (1)	XIN clock off High-speed on-chip oscillator on f _{OCO-F} = 20 MHz Low-speed on-chip oscillator on = 125 kHz No division	–	7.0	14.5
		XIN clock off High-speed on-chip oscillator on f _{OCO-F} = 20 MHz Low-speed on-chip oscillator on = 125 kHz Divide-by-8		–	3.0	–	mA
		Low-speed on-chip oscillator mode	XIN clock off High-speed on-chip oscillator off Low-speed on-chip oscillator on = 125 kHz Divide-by-8, FMR27 = 1, VCA20 = 0	–	85	180	μA
		Wait mode	XIN clock off High-speed on-chip oscillator off Low-speed on-chip oscillator on = 125 kHz While a WAIT instruction is executed Peripheral clock operation VCA27 = VCA26 = VCA25 = 0, VCA20 = 1	–	15	110	μA
			XIN clock off High-speed on-chip oscillator off Low-speed on-chip oscillator on = 125 kHz While a WAIT instruction is executed Peripheral clock off VCA27 = VCA26 = VCA25 = 0, VCA20 = 1	–	5.0	100	μA
		Stop mode	XIN clock off, T _{opr} = 25°C High-speed on-chip oscillator off Low-speed on-chip oscillator off CM10 = 1 Peripheral clock off VCA27 = VCA26 = VCA25 = 0	–	2.0	5.0	μA
			XIN clock off, T _{opr} = 85°C High-speed on-chip oscillator off Low-speed on-chip oscillator off CM10 = 1 Peripheral clock off VCA27 = VCA26 = VCA25 = 0	–	13.0	–	μA

Note:

- The typical value (Typ.) indicates the current value when the CPU and the memory operate.
The maximum value (Max.) indicates the current when the CPU, the memory, and the peripheral functions operate and the flash memory is programmed/erased.

Table 30.26 Electrical Characteristics (6) [2.7 V ≤ V_{CC} < 3.3 V]
(T_{opr} = -40 to 125°C (K version), unless otherwise specified.)

Symbol	Parameter	Condition	Standard			Unit	
			Min.	Typ.	Max.		
I _{CC}	Power supply current (2.7 V ≤ V _{CC} < 3.3 V) Single-chip mode, output pins are open, other pins are V _{SS}	High-speed clock mode (1)	XIN = 20 MHz (square wave) High-speed on-chip oscillator off Low-speed on-chip oscillator on = 125 kHz No division	–	7.0	14.5	mA
			XIN = 16 MHz (square wave) High-speed on-chip oscillator off Low-speed on-chip oscillator on = 125 kHz No division	–	5.6	12	mA
			XIN = 10 MHz (square wave) High-speed on-chip oscillator off Low-speed on-chip oscillator on = 125 kHz No division	–	3.6	–	mA
			XIN = 20 MHz (square wave) High-speed on-chip oscillator off Low-speed on-chip oscillator on = 125 kHz No division	–	3.0	–	mA
			XIN = 16 MHz (square wave) High-speed on-chip oscillator off Low-speed on-chip oscillator on = 125 kHz No division	–	2.2	–	mA
			XIN = 10 MHz (square wave) High-speed on-chip oscillator off Low-speed on-chip oscillator on = 125 kHz No division	–	1.5	–	mA
			High-speed on-chip oscillator mode (1)	XIN clock off High-speed on-chip oscillator on f _{OCO-F} = 20 MHz Low-speed on-chip oscillator on = 125 kHz No division	–	7.0	14.5
		XIN clock off High-speed on-chip oscillator on f _{OCO-F} = 20 MHz Low-speed on-chip oscillator on = 125 kHz Divide-by-8		–	3.0	–	mA
		Low-speed on-chip oscillator mode	XIN clock off High-speed on-chip oscillator off Low-speed on-chip oscillator on = 125 kHz Divide-by-8, FMR27 = 1, VCA20 = 0	–	85	390	μA
		Wait mode	XIN clock off High-speed on-chip oscillator off Low-speed on-chip oscillator on = 125 kHz While a WAIT instruction is executed Peripheral clock operation VCA27 = VCA26 = VCA25 = 0, VCA20 = 1	–	15	320	μA
			XIN clock off High-speed on-chip oscillator off Low-speed on-chip oscillator on = 125 kHz While a WAIT instruction is executed Peripheral clock off VCA27 = VCA26 = VCA25 = 0, VCA20 = 1	–	5.0	310	μA
		Stop mode	XIN clock off, T _{opr} = 25°C High-speed on-chip oscillator off Low-speed on-chip oscillator off CM10 = 1 Peripheral clock off VCA27 = VCA26 = VCA25 = 0	–	2.0	5.0	μA
			XIN clock off, T _{opr} = 85°C High-speed on-chip oscillator off Low-speed on-chip oscillator off CM10 = 1 Peripheral clock off VCA27 = VCA26 = VCA25 = 0	–	55	–	μA

Note:

- The typical value (Typ.) indicates the current value when the CPU and the memory operate.
The maximum value (Max.) indicates the current when the CPU, the memory, and the peripheral functions operate and the flash memory is programmed/erased.

Timing Requirements

(Unless Otherwise Specified: $V_{CC} = 3\text{ V}$, $V_{SS} = 0\text{ V}$ at $T_{opr} = -40^{\circ}\text{C}$ to 85°C (J version)/
 -40°C to 125°C (K version))

Table 30.27 External Clock Input (XOUT)

Symbol	Parameter	Standard		Unit
		Min.	Max.	
$t_{c(XOUT)}$	XOUT input cycle time	50	–	ns
$t_{WH(XOUT)}$	XOUT input "H" width	24	–	ns
$t_{WL(XOUT)}$	XOUT input "L" width	24	–	ns

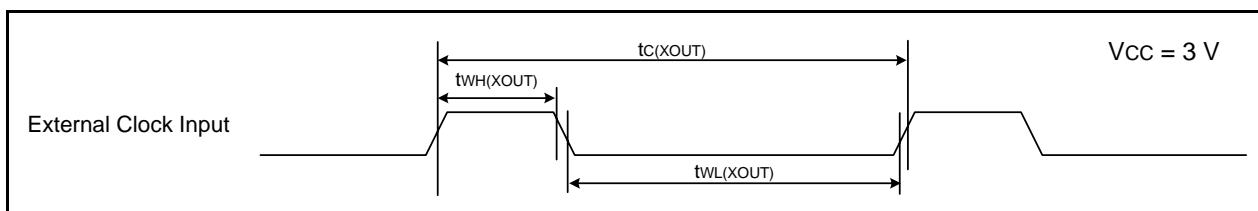
**Figure 30.11 External Clock Input Timing Diagram when $V_{CC} = 3\text{ V}$** **Table 30.28 TRAIO Input**

Symbol	Parameter	Standard		Unit
		Min.	Max.	
$t_{c(TRAIO)}$	TRAIO input cycle time	300	–	ns
$t_{WH(TRAIO)}$	TRAIO input "H" width	120	–	ns
$t_{WL(TRAIO)}$	TRAIO input "L" width	120	–	ns

**Figure 30.12 TRAIO Input Timing Diagram when $V_{CC} = 3\text{ V}$**

Table 30.29 Serial Interface

Symbol	Parameter	Condition	Standard		Unit
			Min.	Max.	
$t_{c(CK)}$	CLKi input cycle time	When external clock selected	300	–	ns
$t_{w(CKH)}$	CLKi input “H” width		150	–	ns
$t_{w(CKL)}$	CLKi Input “L” width		150	–	ns
$t_{d(C-Q)}$	TXDi output delay time		–	120	ns
$t_{h(C-Q)}$	TXDi hold time		0	–	ns
$t_{su(D-C)}$	RXDi input setup time	When internal clock selected	30	–	ns
$t_{h(C-D)}$	RXDi input hold time		90	–	ns
$t_{d(C-Q)}$	TXDi output delay time		–	30	ns
$t_{su(D-C)}$	RXDi input setup time		120	–	ns
$t_{h(C-D)}$	RXDi input hold time		90	–	ns

$i = 0, 2$

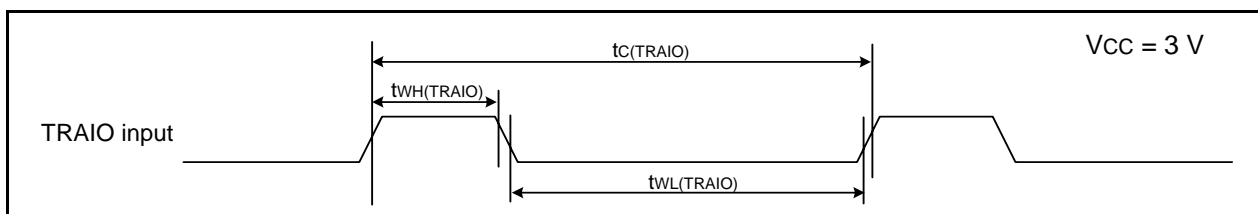
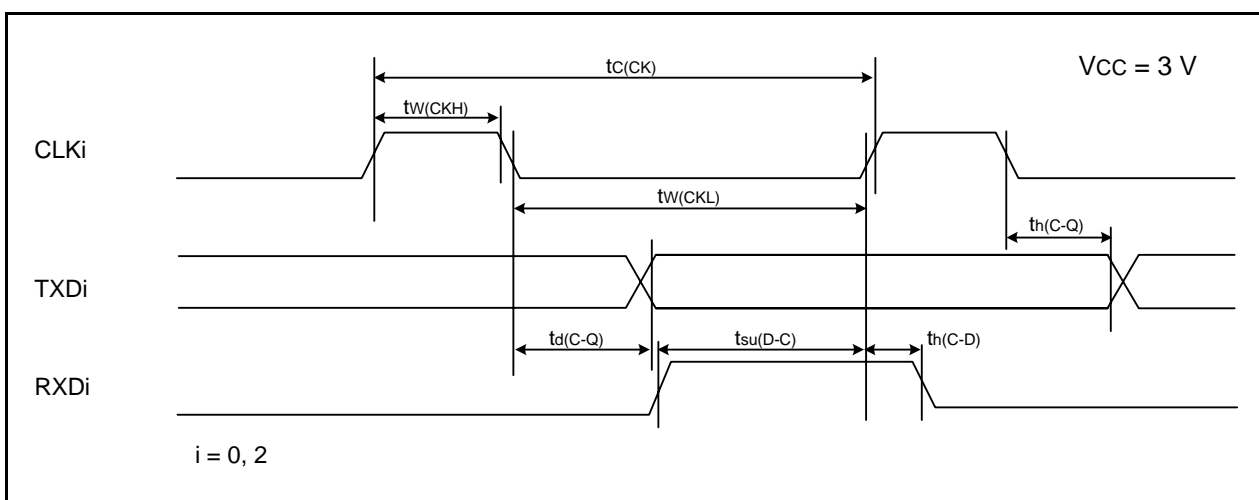

Figure 30.13 Serial Interface Timing Diagram when Vcc = 3 V

Table 30.30 External Interrupt \overline{INTi} ($i = 0$ to 1, 3) Input, Key Input Interrupt \overline{Kli} ($i = 0$ to 3)

Symbol	Parameter	Standard		Unit
		Min.	Max.	
$t_{w(INH)}$	\overline{INTi} input “H” width, \overline{Kli} input “H” width	380 (1)	–	ns
$t_{w(INL)}$	\overline{INTi} input “L” width, \overline{Kli} input “L” width	380 (2)	–	ns

Notes:

1. When selecting the digital filter by the \overline{INTi} input filter select bit, use an \overline{INTi} input HIGH width of either (1/digital filter clock frequency × 3) or the minimum value of standard, whichever is greater.
2. When selecting the digital filter by the \overline{INTi} input filter select bit, use an \overline{INTi} input LOW width of either (1/digital filter clock frequency × 3) or the minimum value of standard, whichever is greater.

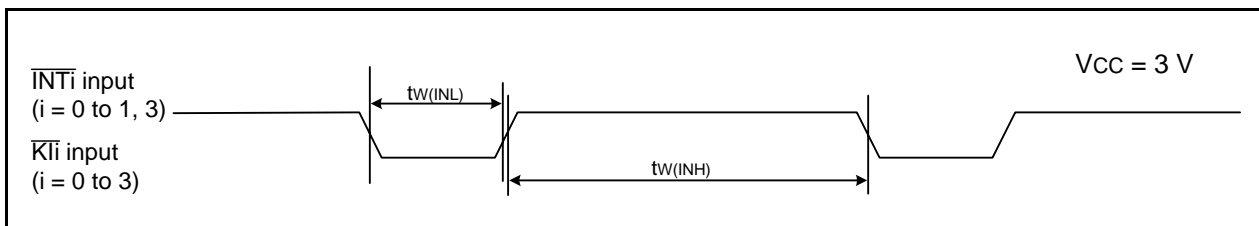

Figure 30.14 Input Timing Diagram for External Interrupt \overline{INTi} and Key Input Interrupt \overline{Kli} when Vcc = 3 V

31. Usage Notes

31.1 Notes on Clock Generation Circuit

31.1.1 Stop Mode

To enter stop mode, set the FMR01 bit in the FMR0 register to 0 (CPU rewrite mode disabled) and then the CM10 bit in the CM1 register to 1 (stop mode). An instruction queue pre-reads 4 bytes from the instruction which sets the CM10 bit to 1 (stop mode) and the program stops.

Insert at least four NOP instructions following the JMP.B instruction after the instruction which sets the CM10 bit to 1.

- Program example to enter stop mode

```

BCLR    1,FMR0    ; CPU rewrite mode disabled
BCLR    7,FMR2    ; Low-current-consumption read mode disabled
BSET    0,PRCR    ; Writing to CM1 register enabled
FSET    I         ; Interrupt enabled
BSET    0,CM1     ; Stop mode
JMP.B   LABEL_001
LABEL_001:
NOP
NOP
NOP
NOP

```

31.1.2 Wait Mode

When entering wait mode, set the FMR01 bit in the FMR0 register to 0 (CPU rewrite mode disabled) and the FMR27 bit to 0 (low-current-consumption read mode disabled) before entering the mode. Do not enter wait mode while the FMR01 bit is 1 (CPU rewrite mode enabled) or the FMR27 bit is 1 (low-current-consumption read mode enabled).

To enter wait mode by setting the CM30 bit to 1, set the I flag to 0 (maskable interrupt disabled).

To enter wait mode using the WAIT instruction, set the I flag to 1 (maskable interrupt enabled). An instruction queue pre-reads 4 bytes from the instruction to set the CM30 bit to 1 (MCU enters wait mode) or the WAIT instruction, and then the program stops. Insert at least four NOP instructions after the instruction to set the CM30 bit to 1 (MCU enters wait mode) or the WAIT instruction.

- Program example to execute the WAIT instruction

```

BCLR    1,FMR0    ; CPU rewrite mode disabled
BCLR    7,FMR2    ; Low-current-consumption read mode disabled
FSET    I         ; Interrupt enabled
WAIT              ; Wait mode
NOP
NOP
NOP
NOP

```

- Program example to execute the instruction to set the CM30 bit to 1

```

BCLR    1, FMR0    ; CPU rewrite mode disabled
BCLR    7, FMR2    ; Low-current-consumption read mode disabled
BSET    0, PRCR    ; Writing to CM3 register enabled
FCLR    I         ; Interrupt disabled
BSET    0, CM3     ; Wait mode
NOP
NOP
NOP
NOP
BCLR    0, PRCR    ; Writing to CM3 register disabled
FSET    I         ; Interrupt enabled

```

31.1.3 Reducing Internal Power Using VCA20 Bit

Set the VCA20 bit to 1 in low-speed clock mode or low-speed on-chip oscillator mode before entering wait mode.

To enter wait mode by setting the CM30 bit in the CM3 register to 1 (MCU enters wait mode), follow the procedure shown in Figure 9.1 to set the procedure for reducing internal power consumption using the VCA20 bit.

To enter wait mode by executing WAIT instruction, follow the procedure shown in Figure 9.2 to set the procedure for reducing internal power consumption using the VCA20 bit.

31.1.4 Oscillation Stop Detection Function

Since the oscillation stop detection function cannot be used if the XIN clock frequency is below 2 MHz, set bits OCD1 to OCD0 to 00b. In addition, the OCD3 bit cannot be used to confirm whether the XIN clock oscillation is stable.

31.1.5 Oscillation Circuit Constants

Consult the oscillator manufacturer to determine the optimal oscillation circuit constants for the user system.

31.2 Notes on Interrupts

31.2.1 Reading Address 00000h

Do not read address 00000h by a program. When a maskable interrupt request is acknowledged, the CPU reads interrupt information (interrupt number and interrupt request level) from 00000h in the interrupt sequence. At this time, the IR bit for the acknowledged interrupt is set to 0.

If address 00000h is read by a program, the IR bit for the interrupt which has the highest priority among the enabled interrupts is set to 0. This may cause the interrupt to be canceled, or an unexpected interrupt to be generated.

31.2.2 SP Setting

Set a value in the SP before an interrupt is acknowledged. The SP is set to 0000h after a reset. If an interrupt is acknowledged before setting a value in the SP, the program may run out of control.

31.2.3 External Interrupt and Key Input Interrupt

Either the “L” level width or “H” level width shown in the Electrical Characteristics is required for the signal input to pins $\overline{\text{INT0}}$ to $\overline{\text{INT1}}$, $\overline{\text{INT3}}$ and pins $\overline{\text{KI0}}$ to $\overline{\text{KI3}}$, regardless of the CPU clock.

For details, refer to **Table 30.23** (VCC = 5V), **Table 30.30** (VCC = 3V) **External Interrupt $\overline{\text{INTi}}$ (i = 0 to 1, 3) Input, Key Input Interrupt $\overline{\text{KIi}}$ (i = 0 to 3)**.

31.2.4 Changing Interrupt Sources

The IR bit in the interrupt control register may be set to 1 (interrupt requested) when the interrupt source changes. To use an interrupt, set the IR bit to 0 (no interrupt requested) after changing interrupt sources. Changing interrupt sources as referred to here includes all factors that change the source, polarity, or timing of the interrupt assigned to a software interrupt number. Therefore, if a mode change of a peripheral function involves the source, polarity, or timing of an interrupt, set the IR bit to 0 (no interrupt requested) after making these changes. Refer to the descriptions of the individual peripheral functions for related interrupts. Figure 31.1 shows a Procedure Example for Changing Interrupt Sources.

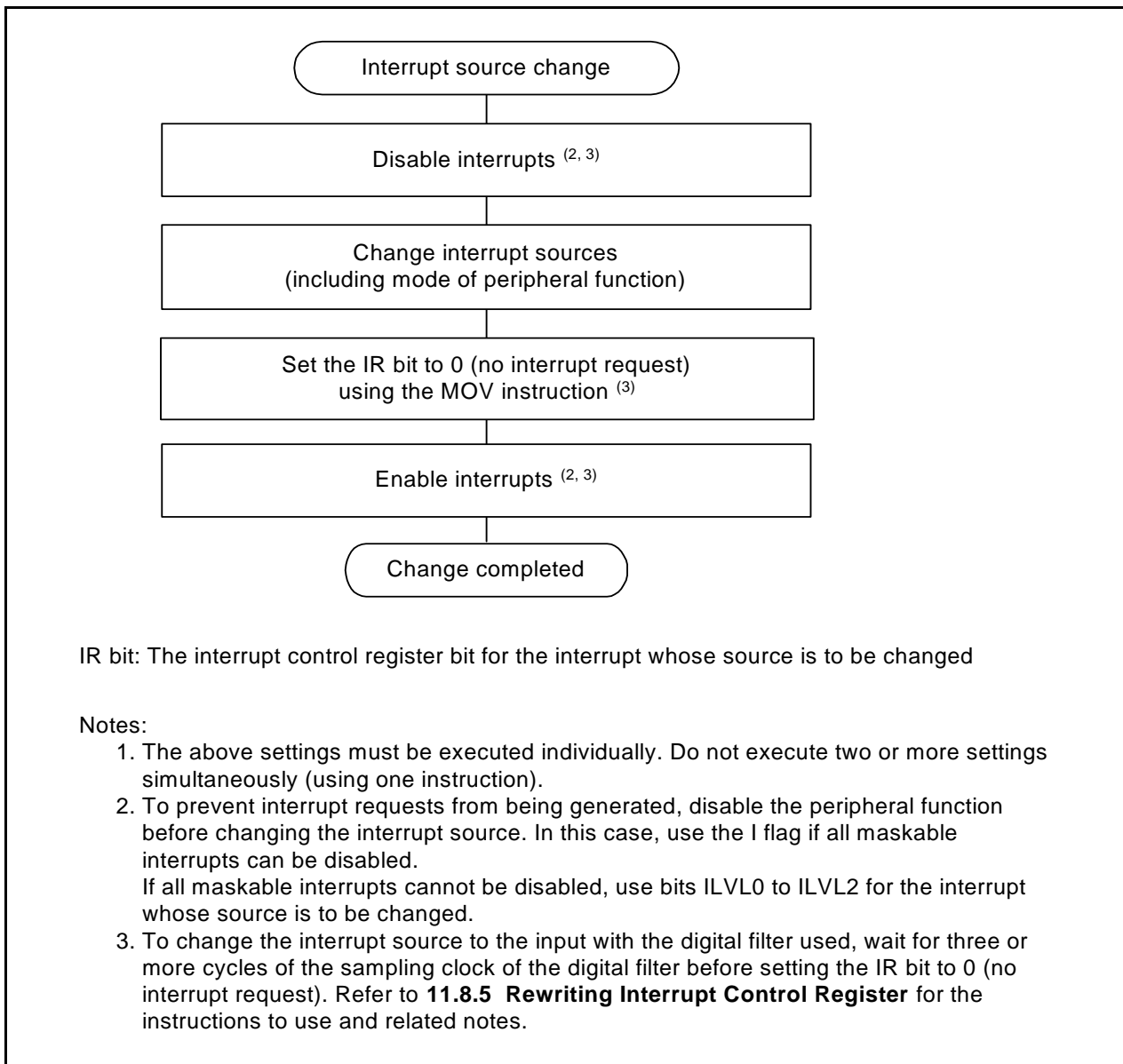

Figure 31.1 Procedure Example for Changing Interrupt Sources

31.2.5 Rewriting Interrupt Control Register

- (a) The contents of the interrupt control register can be rewritten only while no interrupt requests corresponding to that register are generated. If an interrupt request may be generated, disable the interrupt before rewriting the contents of the interrupt control register.
- (b) When rewriting the contents of the interrupt control register after disabling the interrupt, be careful to choose appropriate instructions.

Changing any bit other than the IR bit

If an interrupt request corresponding to the register is generated while executing the instruction, the IR bit may not be set to 1 (interrupt requested), and the interrupt may be ignored. If this causes a problem, use one of the following instructions to rewrite the contents of the register: AND, OR, BCLR, and BSET.

Changing the IR bit

Depending on the instruction used, the IR bit may not be set to 0 (no interrupt requested). Use the MOV instruction to set the IR bit to 0.

- (c) When using the I flag to disable an interrupt, set the I flag as shown in the sample programs below. Refer to (b) regarding rewriting the contents of interrupt control registers using the sample programs.

Examples 1 to 3 shows how to prevent the I flag from being set to 1 (interrupts enabled) before the contents of the interrupt control register are rewritten for the effects of the internal bus and the instruction queue buffer.

Example 1: Use the NOP instructions to pause program until the interrupt control register is rewritten

```
INT_SWITCH1:
  FCLR   I           ; Disable interrupts
  AND.B  #00H,0056H ; Set the TRAIC register to 00h
  NOP                    ;
  NOP                    ;
  FSET   I           ; Enable interrupts
```

Example 2: Use a dummy read to delay the FSET instruction

```
INT_SWITCH2:
  FCLR   I           ; Disable interrupts
  AND.B  #00H,0056H ; Set the TRAIC register to 00h
  MOV.W  MEM,R0      ; Dummy read
  FSET   I           ; Enable interrupts
```

Example 3: Use the POPC instruction to change the I flag

```
INT_SWITCH3:
  PUSHC  FLG
  FCLR   I           ; Disable interrupts
  AND.B  #00H,0056H ; Set the TRAIC register to 00h
  POPC   FLG         ; Enable interrupts
```

31.3 Notes on ID Code Areas

31.3.1 Setting Example of ID Code Areas

The ID code areas are allocated in the flash memory, not in the SFRs. Set appropriate values as ROM data by a program. The following shows a setting example.

- To set 55h in all of the ID code areas

```
.org 00FFDCH
.word dummy | (55000000h) ; UND
.word dummy | (55000000h) ; INTO
.word dummy ; BREAK
.word dummy | (55000000h) ; ADDRESS MATCH
.word dummy | (55000000h) ; SET SINGLE STEP
.word dummy | (55000000h) ; WDT
.word dummy | (55000000h) ; ADDRESS BREAK
.word dummy | (55000000h) ; RESERVE
```

(Programming formats vary depending on the compiler. Check the compiler manual.)

31.4 Notes on Option Function Select Area

31.4.1 Setting Example of Option Function Select Area

The option function select area is allocated in the flash memory, not in the SFRs. Set appropriate values as ROM data by a program. The following shows a setting example.

- To set FFh in the OFS register

```
.org 00FFFCH
.word reset | (0FF00000h) ; RESET
```

(Programming formats vary depending on the compiler. Check the compiler manual.)

- To set FFh in the OFS2 register

```
.org 00FFDBH
.byte 0FFh
```

(Programming formats vary depending on the compiler. Check the compiler manual.)

31.5 Notes on DTC

31.5.1 DTC activation source

- Do not generate any DTC activation sources before entering wait mode or during wait mode.
- Do not generate any DTC activation sources before entering stop mode or during stop mode.

31.5.2 DTCENi (i = 0 to 4, 6) Registers

- Modify bits DTCENi0 to DTCENi7 only while an interrupt request corresponding to the register is not generated.
- When the interrupt source flag in the status register for the peripheral function is 1, do not modify the corresponding activation source bit among bits DTCENi0 to DTCENi7.
- Do not access the DTCENi registers using DTC transfers.

31.5.3 Peripheral Modules

- Do not set the status register bit for the peripheral function to 0 using a DTC transfer.
- When the DTC activation source is SSU receive data full, read the SSRDR register using a DTC transfer. The RDRF bit in the SSSR register is set to 0 (no data in SSRDR) by reading the SSRDR register. However, the RDRF bit is not set to 0 by reading the SSRDR register when the DTC data transfer setting is either of the following:
 - Transfer causing the DTCCTj (j = 0 to 23) register value to change from 1 to 0 in normal mode
 - Transfer causing the DTCCRj register value to change from 1 to 0 while the RPTINT bit in the DTCCRj register is 1 (interrupt generation enabled) in repeat mode
- When the DTC activation source is SSU transmit data empty, write to the SSTDR register using a DTC transfer. The TDRE bit in the SSSR register is set to 0 (data is not transferred from registers SSTDR to SSTRSR) by writing to the SSTDR register.

31.5.4 Interrupt Request

No interrupt is generated for the CPU during DTC operation in any of the following cases:

- When the DTC activation source is SSU transmit data empty or flash ready status
- When performing the data transfer causing the DTCCTj (j = 0 to 23) register value to change to 0 in normal mode
- When performing the data transfer causing the DTCCRj register value to change to 0 while the RPTINT bit in the DTCCRj register is 1 (interrupt generation enabled) in repeat mode

31.5.5 DTC Activation

When the DTC is activated, operation may be shifted for one cycle before reading a vector.

31.5.6 DTC Chain Transfers

When performing chain transfers using several control data, the number of transfers set to the first control data is enabled and the number of transfers proceeded after the first control data is disabled.

Examples:

- When DTCCT0 = 5 and DTCCT1 = 10, chain transfers are performed as DTCCT0 = DTCCT1 = 5.
- When DTCCT0 = 10 and DTCCT1 = 5, chain transfers are performed as DTCCT0 = DTCCT1 = 10.
- When DTCCT0 = 10, DTCCT1 = 5, and DTCCT2 = 2, chain transfers are performed as DTCCT0 = DTCCT1 = DTCCT2 = 10.

31.6 Notes on Timer RA

- Timer RA stops counting after a reset. Set the values in the timer RA and timer RA prescalers before the count starts.
- Even if the prescaler and timer RA are read out in 16-bit units, these registers are read 1 byte at a time by the MCU. Consequently, the timer value may be updated during the period when these two registers are being read.
- In pulse width measurement mode and pulse period measurement mode, bits TEDGF and TUNDF in the TRACR register can be set to 0 by writing 0 to these bits by a program. However, these bits remain unchanged if 1 is written. When using the READ-MODIFY-WRITE instruction for the TRACR register, the TEDGF or TUNDF bit may be set to 0 although these bits are set to 1 while the instruction is being executed. In this case, write 1 to the TEDGF or TUNDF bit which is not supposed to be set to 0 with the MOV instruction.
- When changing to pulse period measurement mode from another mode, the contents of bits TEDGF and TUNDF are undefined. Write 0 to bits TEDGF and TUNDF before the count starts.
- The TEDGF bit may be set to 1 by the first timer RA prescaler underflow generated after the count starts.
- When using the pulse period measurement mode, leave two or more periods of the timer RA prescaler immediately after the count starts, then set the TEDGF bit to 0.
- The TCSTF bit retains 0 (count stops) for 0 to 1 cycle of the count source after setting the TSTART bit to 1 (count starts) while the count is stopped.
Do not write to the TRACR register until the TCSTF bit is set to 1. Also, do not access other registers associated with timer RA ⁽¹⁾.
The TCSTF bit remains 1 for 0 to 1 cycle of the count source after setting the TSTART bit to 0 (count stops) while the count is in progress. Timer RA counting is stopped when the TCSTF bit is set to 0.
Do not write to the TRACR register until the TCSTF bit is set to 0. Also, do not access other registers associated with timer RA ⁽¹⁾.

Note:

1. Registers associated with timer RA: TRAIOC, TRAMR, TRAPRE, and TRA.

- When the TRAPRE register is continuously written during count operation (TCSTF bit is set to 1), allow three or more cycles of the count source clock for each write interval.
- When the TRA register is continuously written during count operation (TCSTF bit is set to 1), allow three or more cycles of the prescaler underflow for each write interval.
- Do not set 00h to the TRA register in pulse width measurement mode and pulse period measurement mode.

31.7 Notes on Timer RB

- Timer RB stops counting after a reset. Set the values in the timer RB and timer RB prescalers before the count starts.
- Even if the prescaler and timer RB is read out in 16-bit units, these registers are read 1 byte at a time by the MCU. Consequently, the timer value may be updated during the period when these two registers are being read.
- In programmable one-shot generation mode and programmable wait one-shot generation mode, when setting the TSTART bit in the TRBCR register to 0 (stops counting) or setting the TOSSP bit in the TRBOCR register to 1 (stops one-shot), the timer reloads the value of reload register and stops. Therefore, in programmable one-shot generation mode and programmable wait one-shot generation mode, read the timer count value before the timer stops.
- The TCSTF bit remains 0 (count stops) for 1 to 2 cycles of the count source after setting the TSTART bit to 1 (count starts) while the count is stopped.

During this time, do not access registers associated with timer RB ⁽¹⁾ other than the TCSTF bit. Timer RB starts counting at the first valid edge of the count source after the TCSTF bit is set to 1 (during count).

The TCSTF bit remains 1 for 1 to 2 cycles of the count source after setting the TSTART bit to 0 (count stops) while the count is in progress. Timer RB counting is stopped when the TCSTF bit is set to 0.

During this time, do not access registers associated with timer RB ⁽¹⁾ other than the TCSTF bit.

Note:

1. Registers associated with timer RB: TRBCR, TRBOCR, TRBIOC, TRBMR, TRBPRES, TRBSC, and TRBPR.

- If the TSTOP bit in the TRBCR register is set to 1 during timer operation, timer RB stops immediately.
- If 1 is written to the TOSST or TOSSP bit in the TRBOCR register, the value of the TOSSTF bit changes after one or two cycles of the count source have elapsed. If the TOSSP bit is written to 1 during the period between when the TOSST bit is written to 1 and when the TOSSTF bit is set to 1, the TOSSTF bit may be set to either 0 or 1 depending on the content state. Likewise, if the TOSST bit is written to 1 during the period between when the TOSSP bit is written to 1 and when the TOSSTF bit is set to 0, the TOSSTF bit may be set to either 0 or 1.
- To use the underflow signal of timer RA as the count source for timer RB, set timer RA in timer mode, pulse output mode, or event count mode.

31.7.1 Timer Mode

To write to registers TRBPRES and TRBPR during count operation (TCSTF bit in the TRBCR register is set to 1), note the following points:

- When the TRBPRES register is written continuously, allow three or more cycles of the count source for each write interval.
- When the TRBPR register is written continuously, allow three or more cycles of the prescaler underflow for each write interval.

31.7.2 Programmable Waveform Generation Mode

To write to registers TRBPRES and TRBPR during count operation (TCSTF bit in the TRBCR register is set to 1), note the following points:

- When the TRBPRES register is written continuously, allow three or more cycles of the count source for each write interval.
- When the TRBPR register is written continuously, allow three or more cycles of the prescaler underflow for each write interval.

31.7.3 Programmable One-shot Generation Mode

To write to registers TRBPRES and TRBPR during count operation (TCSTF bit in the TRBCR register is set to 1), note the following points:

- When the TRBPRES register is written continuously during count operation (TCSTF bit is set to 1), allow three or more cycles of the count source for each write interval.
- When the TRBPR register is written continuously during count operation (TCSTF bit is set to 1), allow three or more cycles of the prescaler underflow for each write interval.

31.7.4 Programmable Wait One-shot Generation Mode

To write to registers TRBPRES and TRBPR during count operation (TCSTF bit in the TRBCR register is set to 1), note the following points:

- When the TRBPRES register is written continuously, allow three or more cycles of the count source for each write interval.
- When the TRBPR register is written continuously, allow three or more cycles of the prescaler underflow for each write interval.

31.8 Notes on Timer RC

31.8.1 TRC Register

- The following note applies when the CCLR bit in the TRCCR1 register is set to 1 (clear TRC register at compare match with TRCGRA register).

When using a program to write a value to the TRC register while the TSTART bit in the TRCMR register is set to 1 (count starts), ensure that the write does not overlap with the timing with which the TRC register is set to 0000h.

If the timing of the write to the TRC register and the setting of the TRC register to 0000h coincide, the write value will not be written to the TRC register and the TRC register will be set to 0000h.

- Reading from the TRC register immediately after writing to it can result in the value previous to the write being read out. To prevent this, execute the JMP.B instruction between the read and the write instructions.

```

Program Example      MOV.W      #XXXXh, TRC          ;Write
                    JMP.B      L1              ;JMP.B instruction
                    L1:         MOV.W      TRC,DATA        ;Read

```

31.8.2 TRCSR Register

Reading from the TRCSR register immediately after writing to it can result in the value previous to the write being read out. To prevent this, execute the JMP.B instruction between the read and the write instructions.

```

Program Example      MOV.B      #XXh, TRCSR        ;Write
                    JMP.B      L1              ;JMP.B instruction
                    L1:         MOV.B      TRCSR,DATA    ;Read

```

31.8.3 TRCCR1 Register

To set bits TCK2 to TCK0 in the TRCCR1 register to 111b (fOCO-F), set fOCO-F to the clock frequency higher than the CPU clock frequency.

31.8.4 Count Source Switching

- Stop the count before switching the count source.

Switching procedure

- Set the TSTART bit in the TRCMR register to 0 (count stops).
- Change the settings of bits TCK2 to TCK0 in the TRCCR1 register.

- When changing the count source from fOCO40M to another clock other than fOCO-F and stopping fOCO40M, wait 2 cycles of f1 or more after setting the clock switch, and then stop fOCO40M.

Switching procedure

- Set the TSTART bit in the TRCMR register to 0 (count stops).
- Change the settings of bits TCK2 to TCK0 in the TRCCR1 register.
- Wait for a minimum of two cycles of f1.
- Set the FRA00 bit in the FRA0 register to 0 (high-speed on-chip oscillator off).

- After switching the count source from fOCO-F to a clock other than fOCO40M, allow a minimum of one cycle of fOCO-F + fOCO40M to elapse after changing the clock setting before stopping fOCO-F.

Switching procedure

- (1) Set the TSTART bit in the TRCMR register to 0 (count stops).
- (2) Change the settings of bits TCK2 to TCK0 in the TRCCR1 register.
- (3) Wait for a minimum of one cycle of fOCO-F + fOCO40M.
- (4) Set the FRA00 bit in the FRA0 register to 0 (high-speed on-chip oscillator off).

31.8.5 Input Capture Function

- Set the pulse width of the input capture signal as follows:
 - [When the digital filter is not used]
Three or more cycles of the timer RC operation clock (refer to **Table 19.1 Timer RC Operation Clock**)
 - [When the digital filter is used]
Five cycles of the digital filter sampling clock + three cycles of the timer RC operating clock, minimum (refer to **Figure 19.5 Digital Filter Block Diagram**)
- The value of the TRC register is transferred to the TRCGRj register one or two cycles of the timer RC operation clock after the input capture signal is input to the TRCIOj (j = A, B, C, or D) pin (when the digital filter function is not used).
- When the input capture function is used, if an edge selected by bits IOj0 and IOj1 (j = A, B, C, or D) in the TRCIOR0 or TRCIOR1 register is input to the TRCIOj pin, the IMFj bit in the TRCSR register is set to 1 even when the TSTART bit in the TRCMR register is 0 (count stops).

31.8.6 TRCMR Register in PWM2 Mode

When the CSEL bit in the TRCCR2 register is set to 1 (count stops at compare match with the TRCGRA register), do not set the TRCMR register at compare match timing of registers TRC and TRCGRA.

31.9 Notes on Timer RD

31.9.1 TRDSTR Register

- Set the TRDSTR register using the MOV instruction.
- When the CSELi (i = 0 to 1) bit is set to 0 (the count stops at compare match of registers TRDi and TRDGRAi), the count does not stop and the TSTARTi bit remains unchanged even if 0 (count stops) is written to the TSTARTi bit.
Therefore, set the TSTARTi bit to 0 to change other bits without changing the TSTARTi bit when the CSELi bit is set to 0.
To stop counting by a program, set the TSTARTi bit after setting the CSELi bit to 1. Although the CSELi bit is set to 1 and the TSTARTi bit is set to 0 at the same time (with 1 instruction), the count cannot be stopped.
- Table 31.1 lists the TRDIOji (j = A, B, C, or D) Pin Output Level when Count Stops to use the TRDIOji (j = A, B, C, or D) pin with the timer RD output.

Table 31.1 TRDIOji (j = A, B, C, or D) Pin Output Level when Count Stops

Count Stop	TRDIOji Pin Output when Count Stops
When the CSELi bit is set to 1, set the TSTARTi bit to 0 and the count stops.	The pin holds the output level immediately before the count stops. (The pin outputs the initial output level selected by bits OLS0 and OLS1 in the TRDFCR register in complementary and reset synchronous PWM modes.)
When the CSELi bit is set to 0, the count stops at compare match of registers TRDi and TRDGRAi.	The pin holds the output level after the output changes by compare match. (The pin outputs the initial output level selected by bits OLS0 and OLS1 in the TRDFCR register in complementary and reset synchronous PWM modes.)

31.9.2 TRDi Register (i = 0 or 1)

- When writing the value to the TRDi register by a program while the TSTARTi bit in the TRDSTR register is set to 1 (count starts), avoid overlapping with the timing for setting the TRDi register to 0000h, and then write.

If the timing for setting the TRDi register to 0000h overlaps with the timing for writing the value to the TRDi register, the value is not written and the TRDi register is set to 0000h.

These precautions are applicable when selecting the following by bits CCLR2 to CCLR0 in the TRDCRi register.

- 001b (Clear the TRDi register by input capture/compare match in the TRDGRAi register.)
- 010b (Clear the TRDi register by input capture/compare match in the TRDGRBi register.)
- 011b (Synchronous clear)
- 101b (Clear the TRDi register by input capture/compare match in the TRDGRCi register.)
- 110b (Clear the TRDi register by input capture/compare match in the TRDGRDi register.)

- When writing the value to the TRDi register and continuously reading the same register, the value before writing may be read. In this case, execute the JMP.B instruction between the writing and reading.

```

Program example      MOV.W    #XXXXh, TRD0      ;Writing
                    JMP.B    L1                          ;JMP.B
                    L1:     MOV.W    TRD0,DATA            ;Reading

```

31.9.3 TRDSRi Register (i = 0 or 1)

When writing the value to the TRDSRi register and continuously reading the same register, the value before writing may be read. In this case, execute the JMP.B instruction between the writing and reading.

```

Program example      MOV.B    #XXh, TRDSR0             ;Writing
                    JMP.B    L1                          ;JMP.B
                    L1:     MOV.B    TRDSR0,DATA        ;Reading

```

31.9.4 TRDCRi Register (i = 0 or 1)

To set bits TCK2 to TCK0 in the TRDCRi register to 111b (fOCO-F), set fOCO-F to the clock frequency higher than the CPU clock frequency.

31.9.5 Count Source Switch

- Switch the count source after the count stops.

Switching procedure

- (1) Set the TSTART_i (i = 0 or 1) bit in the TRDSTR register to 0 (count stops).
- (2) Change bits TCK2 to TCK0 in the TRDCR_i register.

- When changing the count source from fOCO40M to another clock other than fOCO-F and stopping fOCO40M, wait 2 cycles of f1 or more after setting the clock switch, and then stop fOCO40M.

Switching procedure

- (1) Set the TSTART_i (i = 0 or 1) bit in the TRDSTR register to 0 (count stops).
- (2) Change bits TCK2 to TCK0 in the TRDCR_i register.
- (3) Wait 2 or more cycles of f1.
- (4) Set the FRA00 bit in the FRA0 register to 0 (high-speed on-chip oscillator stops).

- After switching the count source from fOCO-F to a clock other than fOCO40M, allow a minimum of one cycle of fOCO-F + fOCO40M to elapse after changing the clock setting before stopping fOCO-F.

Switching procedure

- (1) Set the TSTART_i (i = 0 to 1) bit in the TRDSTR register to 0 (count stops).
- (2) Change the settings of bits TCK2 to TCK0 in the TRDCR_i register.
- (3) Wait for a minimum of one cycle of fOCO-F + fOCO40M.
- (4) Set the FRA00 bit in the FRA0 register to 0 (high-speed on-chip oscillator off).

31.9.6 Input Capture Function

- Set the pulse width of the input capture signal to 3 or more cycles of the timer RD operation clock (refer to **Table 20.1 Timer RD Operation Clocks**).
- The value in the TRD_i register is transferred to the TRDGR_{ji} register 2 to 3 cycles of the timer RD operation clock after the input capture signal is applied to the TRDIO_{ji} (i = 0 or 1, j = A, B, C, or D) pin (no digital filter).
- When the input capture function is used, if an edge selected by bits IO_j0 and IO_j1 in the TRDIOR_{Ai} or TRDIOR_{Ci} register (i = 0 or 1, j = A, B, C, or D) is input to the TRDIO_{ji} pin, the IMF_j bit in the TRDSR_i register is set to 1 even when the TSTART_i bit in the TRDSTR register is 0 (count stops).

31.9.7 Reset Synchronous PWM Mode

- When reset synchronous PWM mode is used for motor control, make sure OLS0 = OLS1.
- Set to reset synchronous PWM mode by the following procedure:

Switching procedure

- (1) Set the TSTART0 bit in the TRDSTR register to 0 (count stops).
- (2) Set bits CMD1 to CMD0 in the TRDFCR register to 00b (timer mode, PWM mode, and PWM3 mode).
- (3) Set bits CMD1 to CMD0 to 01b (reset synchronous PWM mode).
- (4) Set the other registers associated with timer RD again.

31.9.8 Complementary PWM Mode

- When complementary PWM mode is used for motor control, make sure OLS0 = OLS1.
- Change bits CMD1 to CMD0 in the TRDFCR register in the following procedure.
Switching procedure: When setting to complementary PWM mode (including re-set), or changing the transfer timing from the buffer register to the general register in complementary PWM mode.

- (1) Set both the TSTART0 and TSTART1 bits in the TRDSTR register to 0 (count stops).
- (2) Set bits CMD1 to CMD0 in the TRDFCR register to 00b (timer mode, PWM mode, and PWM3 mode).
- (3) Set bits CMD1 to CMD0 to 10b or 11b (complementary PWM mode).
- (4) Set the registers associated with other timer RD again.

Switching procedure: When stopping complementary PWM mode

- (1) Set both the TSTART0 and TSTART1 bits in the TRDSTR register to 0 (count stops).
- (2) Set bits CMD1 to CMD0 to 00b (timer mode, PWM mode, and PWM3 mode).

- Do not write to TRDGRA0, TRDGRB0, TRDGRA1, or TRDGRB1 register during operation.
When changing the PWM waveform, transfer the values written to registers TRDGRD0, TRDGRC1, and TRDGRD1 to registers TRDGRB0, TRDGRA1, and TRDGRB1 using the buffer operation.
However, to write data to the TRDGRD0, TRDGRC1, or TRDGRD1 register, set bits BFD0, BFC1, and BFD1 to 0 (general register). After this, bits BFD0, BFC1, and BFD1 may be set to 1 (buffer register).
The PWM period cannot be changed.
- If the value in the TRDGRA0 register is assumed to be m , the TRD0 register counts $m-1$, m , $m+1$, m , $m-1$, in that order, when changing from increment to decrement operation.
When changing from m to $m+1$, the IMFA bit is set to 1. Also, bits CMD1 to CMD0 in the TRDFCR register are set to 11b (complementary PWM mode, buffer data transferred at compare match between registers TRD0 and TRDGRA0), the content in the buffer registers (TRDGRD0, TRDGRC1, and TRDGRD1) is transferred to the general registers (TRDGRB0, TRDGRA1, and TRDGRB1).
During $m+1$, m , and $m-1$ operation, the IMFA bit remains unchanged and data are not transferred to registers such as the TRDGRA0 register.

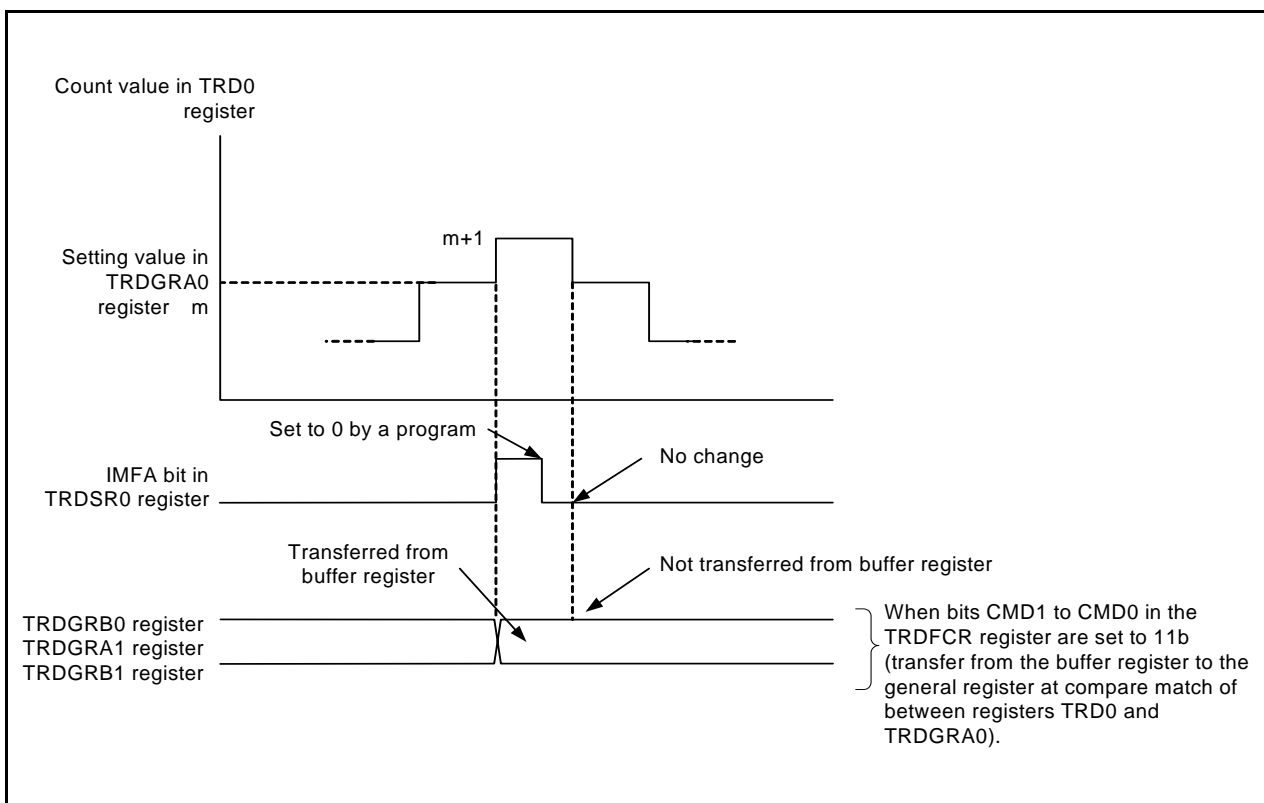

Figure 31.2 Operation at Compare Match between Registers TRD0 and TRDGRA0 in Complementary PWM Mode

- The TRD1 register counts 1, 0, FFFFh, 0, 1, in that order, when changing from decrement to increment operation.

The UDF bit is set to 1 when changing between 1, 0, and FFFFh operation. Also, when bits CMD1 to CMD0 in the TRDFCR register are set to 10b (complementary PWM mode, buffer data transferred at underflow in the TRD1 register), the content in the buffer registers (TRDGRD0, TRDGRC1, and TRDGRD1) is transferred to the general registers (TRDGRB0, TRDGRA1, and TRDGRB1). During FFFFh, 0, 1 operation, data are not transferred to registers such as the TRDGRB0 register. Also, at this time, the OVF bit remains unchanged.

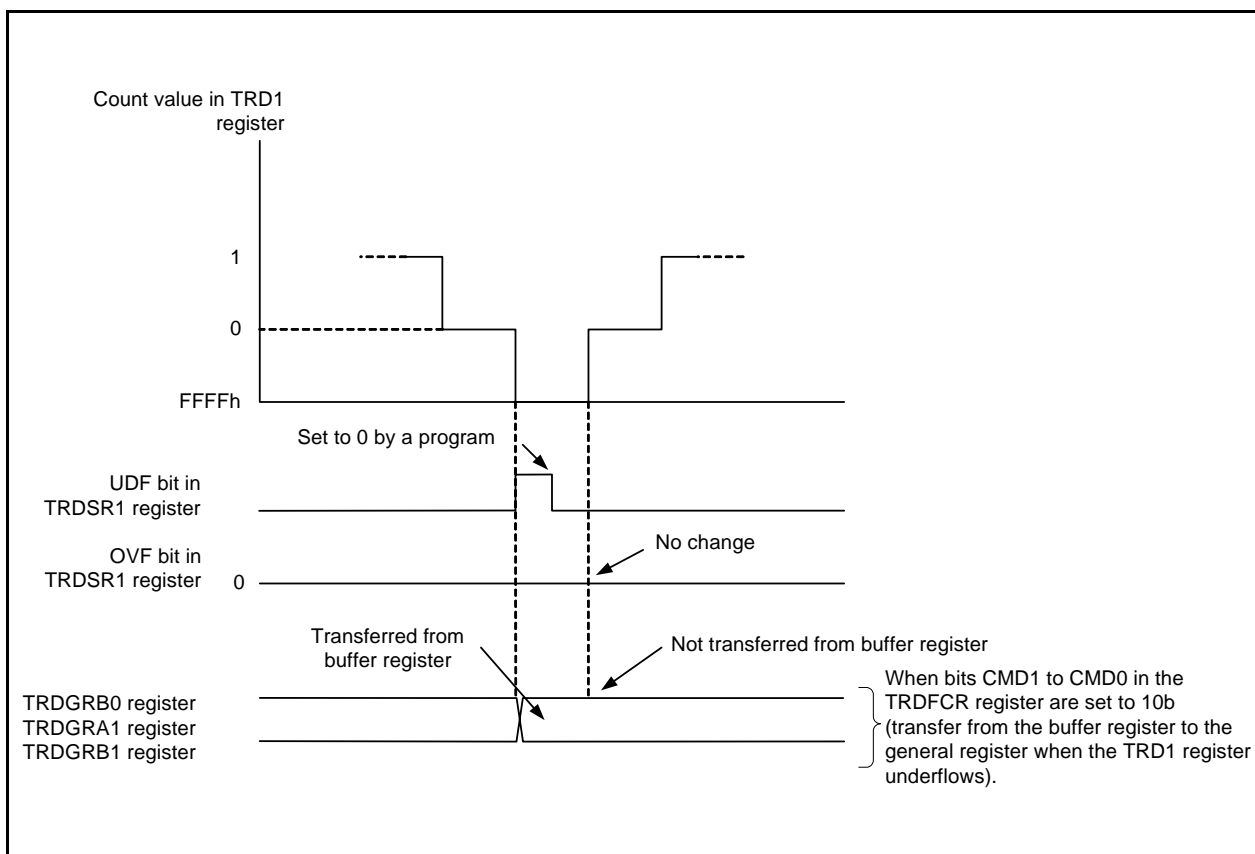

Figure 31.3 Operation when TRD1 Register Underflows in Complementary PWM Mode

- Select with bits CMD1 to CMD0 the timing of data transfer from the buffer register to the general register. However, transfer takes place with the following timing in spite of the value of bits CMD1 to CMD0 in the following cases:

Value in buffer register \geq value in TRDGRA0 register:

Transfer takes place at underflow of the TRD1 register.

After this, when the buffer register is set to 0001h or above and a smaller value than the value of the TRDGRA0 register, and the TRD1 register underflows for the first time after setting, the value is transferred to the general register. After that, the value is transferred with the timing selected by bits CMD1 to CMD0.

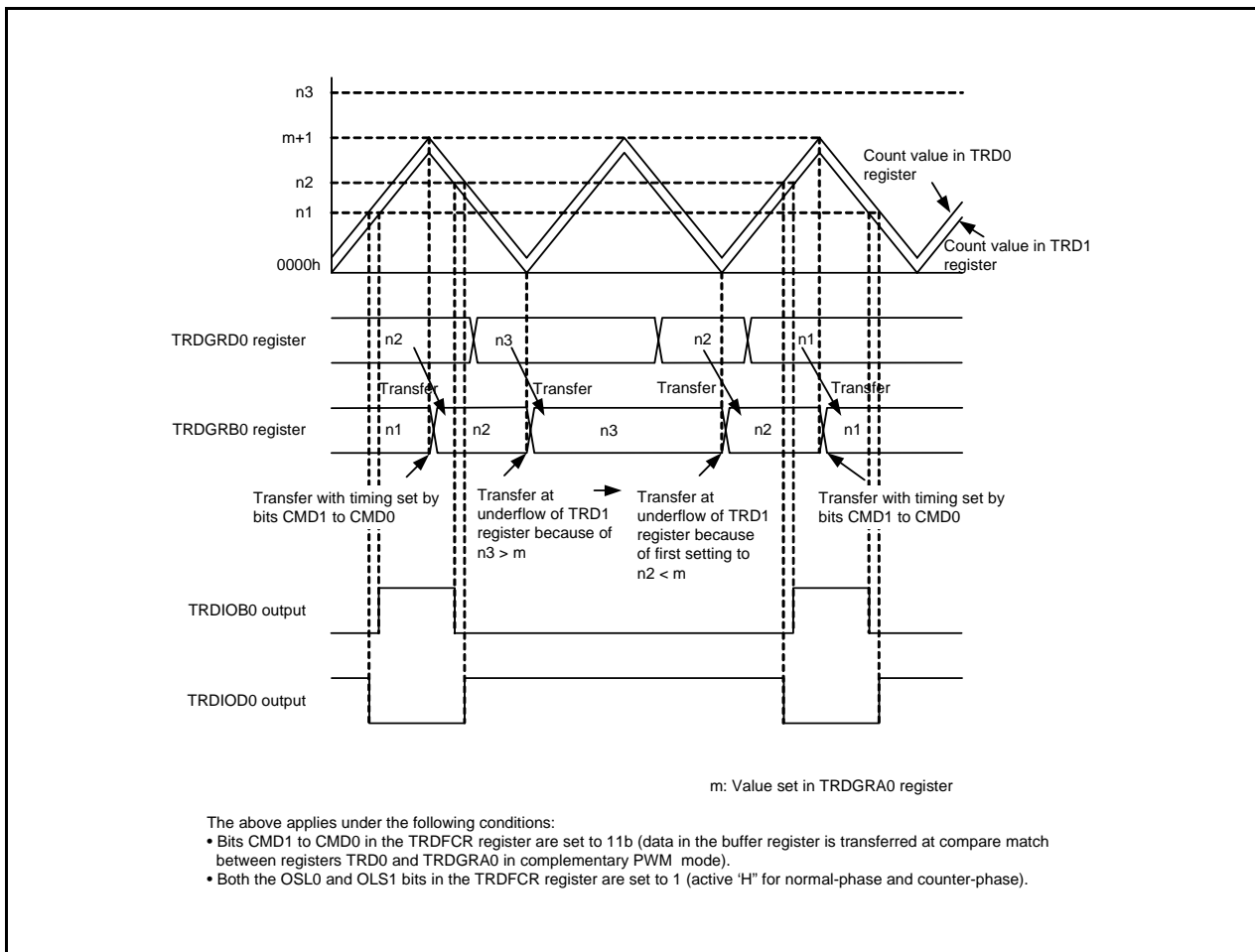

Figure 31.4 Operation when Value in Buffer Register \geq Value in TRDGRA0 Register in Complementary PWM Mode

When the value in the buffer register is set to 0000h:

Transfer takes place at compare match between registers TRD0 and TRDGRA0.

After this, when the buffer register is set to 0001h or above and a smaller value than the value of the TRDGRA0 register, and a compare match occurs between registers TRD0 and TRDGRA0 for the first time after setting, the value is transferred to the general register. After that, the value is transferred with the timing selected by bits CMD1 to CMD0.

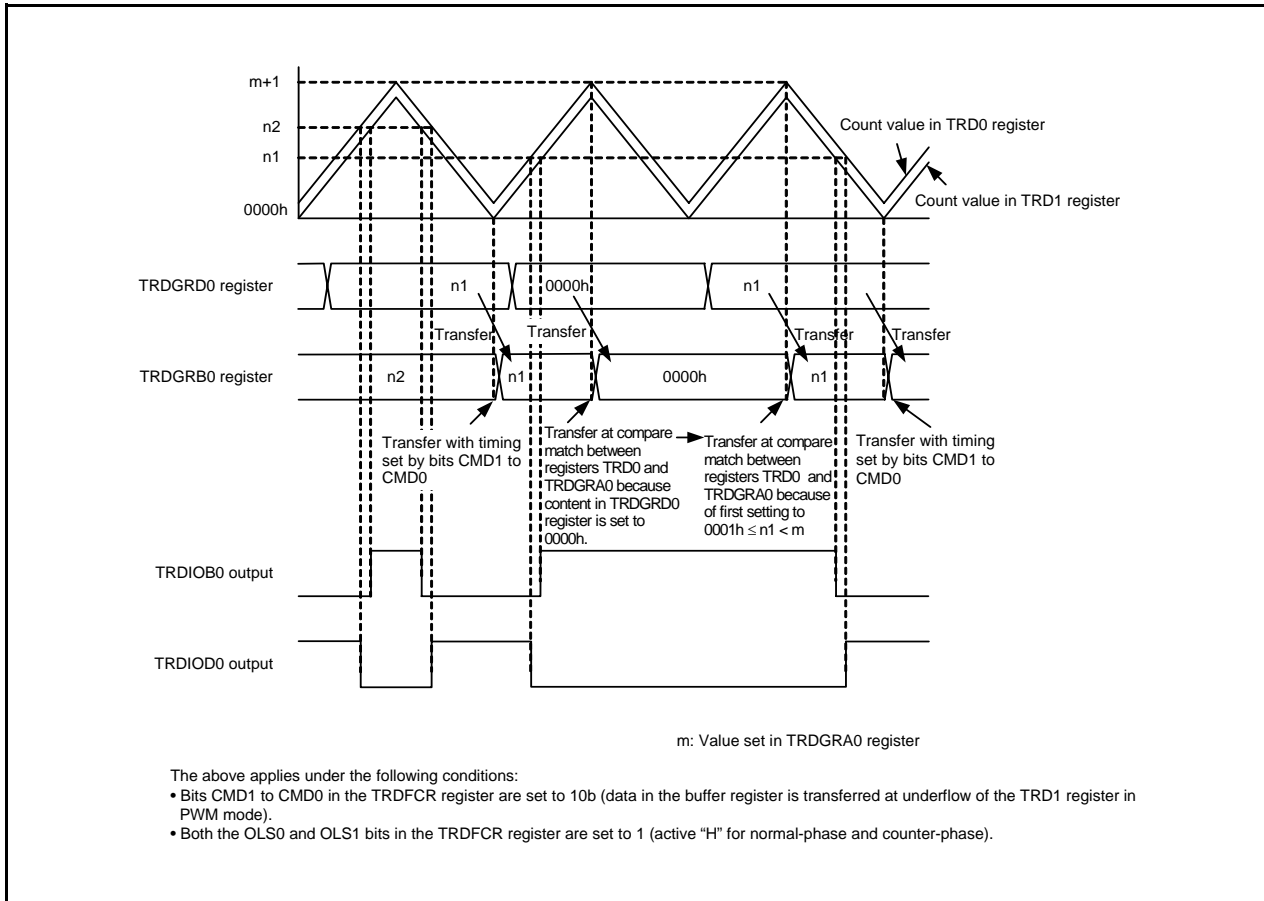

Figure 31.5 Operation when Value in Buffer Register Is Set to 0000h in Complementary PWM Mode

31.9.9 Count Source fOCO40M

The count source fOCO40M can be used with supply voltage $V_{CC} = 2.7$ to 5.5 V. For supply voltage other than that, do not set bits TCK2 to TCK0 in registers TRDCR0 and TRDCR to 110b (select fOCO40M as the count source).

31.10 Notes on Serial Interface (UART0)

- When reading data from the UORB register either in clock synchronous serial I/O mode or in clock asynchronous serial I/O mode, always read data in 16-bit units.

When the high-order byte of the UORB register is read, bits PER and FER in the UORB register and the RI bit in the UOC1 register are set to 0.

To check receive errors, read the UORB register and then use the read data.

Program example to read the receive buffer register:

```
MOV.W    00A6H,R0    ; Read the UORB register
```

- When writing data to the UOTB register in clock asynchronous serial I/O mode with 9-bit transfer data length, write data to the high-order byte first and then the low-order byte, in 8-bit units.

Program example to write to the transmit buffer register:

```
MOV.B    #XXH,00A3H  ; Write to the high-order byte of the UOTB register  
MOV.B    #XXH,00A2H  ; Write to the low-order byte of the UOTB register
```

31.11 Notes on Serial Interface (UART2)

31.11.1 Clock Synchronous Serial I/O Mode

31.11.1.1 Transmission/Reception

When the $\overline{\text{RTS}}$ function is used with an external clock, the $\overline{\text{RTS2}}$ pin outputs “L,” which informs the transmitting side that the MCU is ready for a receive operation. The $\overline{\text{RTS2}}$ pin outputs “H” when a receive operation starts. Therefore, the transmit timing and receive timing can be synchronized by connecting the $\overline{\text{RTS2}}$ pin to the $\overline{\text{CTS2}}$ pin of the transmitting side. The $\overline{\text{RTS}}$ function is disabled when an internal clock is selected.

31.11.1.2 Transmission

If an external clock is selected, the following conditions must be met while the external clock is held high when the CKPOL bit in the U2C0 register is set to 0 (transmit data output at the falling edge and receive data input at the rising edge of the transfer clock), or while the external clock is held low when the CKPOL bit is set to 1 (transmit data output at the rising edge and receive data input at the falling edge of the transfer clock).

- The TE bit in the U2C1 register = 1 (transmission enabled)
- The TI bit in the U2C1 register = 0 (data present in the U2TB register)
- If the $\overline{\text{CTS}}$ function is selected, input on the $\overline{\text{CTS2}}$ pin = “L”

31.11.1.3 Reception

In clock synchronous serial I/O mode, the shift clock is generated by activating the transmitter. Set the UART2-associated registers for transmit operation even if the MCU is used for receive operation only. Dummy data is output from the TXD2 pin while receiving.

When an internal clock is selected, the shift clock is generated by setting the TE bit in the U2C1 register to 1 (transmission enabled) and placing dummy data in the U2TB register. When an external clock is selected, set the TE bit to 1 (transmission enabled), place dummy data in the U2TB register, and input an external clock to the CLK2 pin to generate the shift clock.

If data is received consecutively, an overrun error occurs when the RE bit in the U2C1 register is set to 1 (data present in the U2RB register) and the next receive data is received in the UART2 receive register. Then, the OER bit in the U2RB register is set to 1 (overrun error). At this time, the U2RB register value is undefined. If an overrun error occurs, the IR bit in the S2RIC register remains unchanged.

To receive data consecutively, set dummy data in the low-order byte in the U2TB register per each receive operation.

If an external clock is selected, the following conditions must be met while the external clock is held high when the CKPOL bit is set to 0, or while the external clock is held low when the CKPOL bit is set to 1.

- The RE bit in the U2C1 register = 1 (reception enabled)
- The TE bit in the U2C1 register = 1 (transmission enabled)
- The TI bit in the U2C1 register = 0 (data present in the U2TB register)

31.11.2 Special Mode 1 (I²C Mode)

When generating start, stop, and restart conditions, set the STSPSEL bit in the U2SMR4 register to 0 and wait for more than half cycle of the transfer clock before changing each condition generation bit (STAREQ, RSTAREQ, and STPREQ) from 0 to 1.

31.11.3 UART2 Bit Rate Register (U2BRG)

Immediately after writing 00h to the U2BRG register, there may be a delay of up to 256 cycles of the count source when the following data transmission/reception starts (including the timing when the TI bit in the U2C1 register is set to 0 (data present in the U2TB register)) and when the start bit is detected during reception).

31.11.4 U2TB register

Write to this register using the MOV instruction.

When the multiprocessor communication function is used, write in 8-bit units. Set bits b0 to b7 after setting the MPTB bit.

When the multiprocessor communication function is not used, if the transfer data length is 9 bits, write in 16-bit units or write to the higher byte first and then the lower byte in 8-bit units.

31.12 Notes on Hardware LIN

For the time-out processing of the header and response fields, use another timer to measure the duration of time with a Synch Break detection interrupt as the starting point.

31.13 Notes on A/D Converter

- Write to the ADMOD register, the ADINSEL register, the ADCON0 register (other than ADST bit), the ADCON1 register, the OCVREFCR register when A/D conversion is stopped (before a trigger occurs).
- To use the A/D converter in repeat mode 0, repeat mode 1, or repeat sweep mode, select the frequency of the A/D converter operating clock ϕ_{AD} or more for the CPU clock during A/D conversion.
Do not select fOCO-F as ϕ_{AD} .
- Connect 0.1 μ F capacitor between the VREF pin and AVSS pin.
- Do not enter stop mode during A/D conversion.
- Do not enter wait mode during A/D conversion regardless of the state of the CM02 bit in the CM0 register (1: Peripheral function clock stops in wait mode or 0: Peripheral function clock does not stop in wait mode).
- Do not set the FMSTP bit in the FMR0 register to 1 (flash memory stops) or the FMR27 bit to 1 (low-current-consumption read mode enabled) during A/D conversion. Otherwise, the A/D conversion result will be undefined.
- Do not change the CKS2 bit in the ADMOD register while fOCO-F is stopped.
- During an A/D conversion operation, if the ADST bit in the ADCON0 register is set to 0 (A/D conversion stops) by a program to forcibly terminate A/D conversion, the conversion result of the A/D converter is undefined and no interrupt is generated. The value of the ADi register before A/D conversion may also be undefined.
If the ADST bit is set to 0 by a program, do not use the value of all the ADi register.

31.14 Notes on Flash Memory

31.14.1 CPU Rewrite Mode

31.14.1.1 Prohibited Instructions

The following instructions cannot be used while the program ROM area is being rewritten in EW0 mode because they reference data in the flash memory: UND, INTO, and BRK.

31.14.1.2 Interrupts

Tables 31.2 to 31.4 show CPU Rewrite Mode Interrupts (1), (2) and (3), respectively.

Table 31.2 CPU Rewrite Mode Interrupts (1)

Mode	Erase/Write Target	Status	Maskable Interrupt
EW0	Data flash (1)	During auto-erase (suspend enabled)	When an interrupt request is acknowledged, interrupt handling is executed. If the FMR22 bit is set to 1 (erase-suspend request enabled by interrupt request), the FMR21 bit is automatically set to 1 (erase-suspend request). The flash memory suspends auto-erase after td(SR-SUS). If erase-suspend is required while the FMR22 bit is set to 0 (erase-suspend request disabled by interrupt request), set the FMR21 bit to 1 during interrupt handling. The flash memory suspends auto-erase after td(SR-SUS). While auto-erase is being suspended, any block other than the block during auto-erase execution can be read or written. Auto-erase can be restarted by setting the FMR21 bit to 0 (erase restart).
		During auto-erase (suspend disabled or FMR22 = 0)	Interrupt handling is executed while auto-erase or auto-programming is being performed.
		During auto-programming	
	Program ROM	During auto-erase (suspend enabled)	Usable by allocating a vector in RAM.
		During auto-erase (suspend disabled)	
		During auto-programming	
EW1	Data flash (1)	During auto-erase (suspend enabled)	When an interrupt request is acknowledged, interrupt handling is executed. If the FMR22 bit is set to 1, the FMR21 bit is automatically set to 1. The flash memory suspends auto-erase after td(SR-SUS). If erase-suspend is required while the FMR22 bit is set to 0, set the FMR21 bit to 1 during interrupt handling. The flash memory suspends auto-erase after td(SR-SUS). While auto-erase is being suspended, any block other than the block during auto-erase execution can be read or written. Auto-erase can be restarted by setting the FMR21 bit to 0.
		During auto-erase (suspend disabled or FMR22 = 0)	Interrupt handling is executed while auto-erase or auto-programming is being performed.
		During auto-programming	
	Program ROM	During auto-erase (suspend enabled)	Auto-erase suspends after td(SR-SUS) and interrupt handling is executed. Auto-erase can be restarted by setting the FMR21 bit to 0 after interrupt handling completes. While auto-erase is being suspended, any block other than the block during auto-erase execution can be read or written.
		During auto-erase (suspend disabled or FMR22 = 0)	Auto-erase and auto-programming have priority and interrupt requests are put on standby. Interrupt handling is executed after auto-erase and auto-program complete.
		During auto-programming	

FMR21, FMR22: Bits in FMR2 register

Note:

1. The R8C/33G Group Group has data flash.

Table 31.3 CPU Rewrite Mode Interrupts (2)

Mode	Erase/ Write Target	Status	<ul style="list-style-type: none"> • Watchdog Timer • Oscillation Stop Detection • Voltage Monitor 2 • Voltage Monitor 1 <p style="text-align: right;">(Note 1)</p>	<ul style="list-style-type: none"> • Undefined Instruction • INTO Instruction • BRK Instruction • Single Step • Address Match • Address Break <p style="text-align: right;">(Note 1)</p>
EW0	Data flash	During auto-erasure (suspend enabled) ⁽²⁾	When an interrupt request is acknowledged, interrupt handling is executed. If the FMR22 bit is set to 1 (erase-suspend request enabled by interrupt request), the FMR21 bit is automatically set to 1 (erase-suspend request). The flash memory suspends auto-erasure after td(SR-SUS). If erase-suspend is required while the FMR22 bit is set to 0 (erase-suspend request disabled by interrupt request), set the FMR21 bit to 1 during interrupt handling. The flash memory suspends auto-erasure after td(SR-SUS). While auto-erasure is being suspended, any block other than the block during auto-erasure execution can be read or written. Auto-erasure can be restarted by setting the FMR21 bit is set to 0 (erase restart).	When an interrupt request is acknowledged, interrupt handling is executed. If erase-suspend is required, set the FMR21 bit to 1 during interrupt handling. The flash memory suspends auto-erasure after td(SR-SUS). While auto-erasure is being suspended, any block other than the block during auto-erasure execution can be read or written. Auto-erasure can be restarted by setting the FMR21 bit in the FMR2 register is set to 0 (erase restart).
		During auto-erasure (suspend disabled or FMR22 = 0)	Interrupt handling is executed while auto-erasure or auto-programming is being performed.	
	During auto-programming			
	Program ROM	During auto-erasure (suspend enabled)	When an interrupt request is acknowledged, auto-erasure or auto-programming is forcibly stopped immediately and the flash memory is reset. Interrupt handling starts when the flash memory restarts after the fixed period. Since the block during auto-erasure or the address during auto-programming is forcibly stopped, the normal value may not be read. After the flash memory restarts, execute auto-erasure again and ensure it completes normally. The watchdog timer does not stop during the command operation, so interrupt requests may be generated. Initialize the watchdog timer regularly using the erase-suspend function.	Not usable during auto-erasure or auto-programming.
	During auto-erasure (suspend disabled)			
	During auto-programming			

FMR21, FMR22: Bits in FMR2 register

Notes:

1. Do not use a non-maskable interrupt while block 0 is being auto-erased because the fixed vector is allocated in block 0.
2. The R8C/33G Group Group has data flash.

Table 31.4 CPU Rewrite Mode Interrupts (3)

Mode	Erase/ Write Target	Status	<ul style="list-style-type: none"> • Watchdog Timer • Oscillation Stop Detection • Voltage Monitor 2 • Voltage Monitor 1 <p style="text-align: right;">(Note 1)</p>	<ul style="list-style-type: none"> • Undefined Instruction • INTO Instruction • BRK Instruction • Single Step • Address Match • Address Break <p style="text-align: right;">(Note 1)</p>
EW1	Data flash	During auto-erase (suspend enabled) ⁽²⁾	When an interrupt request is acknowledged, interrupt handling is executed. If the FMR22 bit is set to 1, the FMR21 bit is automatically set to 1. The flash memory suspends auto-erase after td(SR-SUS). If erase-suspend is required while the FMR22 bit is set to 0, set the FMR21 bit to 1 during interrupt handling. The flash memory suspends auto-programming after td(SR-SUS). While auto-erase is being suspended, any block other than the block during auto-erase execution can be read or written. Auto-erase can be restarted by setting the FMR21 bit is set to 0.	When an interrupt request is acknowledged, interrupt handling is executed. If erase-suspend is required, set the FMR21 bit to 1 during interrupt handling. The flash memory suspends auto-erase after td(SR-SUS). While auto-erase is being suspended, any block other than the block during auto-erase execution can be read or written. Auto-erase can be restarted by setting the FMR21 bit in the FMR2 register is set to 0 (erase restart).
		During auto-erase (suspend disabled or FMR22 = 0)	Interrupt handling is executed while auto-erase or auto-programming is being performed.	
		During auto-programming		
	Program ROM	During auto-erase (suspend enabled)	When an interrupt request is acknowledged, auto-erase or auto-programming is forcibly stopped immediately and the flash memory is reset. Interrupt handling starts when the flash memory restarts after the fixed period.	Not usable during auto-erase or auto-programming.
		During auto-erase (suspend disabled or FMR22 = 0)	Since the block during auto-erase or the address during auto-programming is forcibly stopped, the normal value may not be read. After the flash memory restarts, execute auto-erase again and ensure it completes normally.	
		During auto-programming	The watchdog timer does not stop during the command operation, so interrupt requests may be generated. Initialize the watchdog timer regularly using the erase-suspend function.	

FMR21, FMR22: Bits in FMR2 register

Notes:

1. Do not use a non-maskable interrupt while block 0 is being auto-erased because the fixed vector is allocated in block 0.
2. The R8C/33G Group has data flash.

31.14.1.3 How to Access

To set one of the following bits to 1, first write 0 and then 1 immediately. Disable interrupts and DTC activation between writing 0 and writing 1.

- The FMR01 bit or FMR02 bit in the FMR0 register
- The FMR13 bit in the FMR1 register
- The FMR20 bit, FMR22 bit, or FMR 27 bit in the FMR2 register

To set one of the following bits to 0, first write 1 and then 0 immediately. Disable interrupts and DTC activation between writing 1 and writing 0.

- The FMR14 bit, FMR15 bit, FMR16 bit, or FMR17 bit in the FMR1 register

31.14.1.4 Rewriting User ROM Area

In EW0 mode, if the supply voltage drops while rewriting any block in which a rewrite control program is stored, it may not be possible to rewrite the flash memory because the rewrite control program cannot be rewritten correctly. In this case, use standard serial I/O mode.

31.14.1.5 Programming

Do not write additions to the already programmed address.

31.14.1.6 Entering Stop Mode or Wait Mode

Do not enter stop mode or wait mode during erase-suspend.

If the FST7 bit in the FST register is set to 0 (busy (during programming or erasure execution)), do not enter to stop mode or wait mode.

Do not enter stop mode or wait mode while the FMR27 bit is 1 (low-current-consumption read mode enabled).

31.14.1.7 Note when data flash is used

To use data flash with more than 16 MHz CPU clock, set the FMR23 bit in the FMR2 register to 1 (4 cycles of the CPU clock).

31.14.1.8 Low-Current-Consumption Read Mode

In low-speed clock mode and low-speed on-chip oscillator mode, the current consumption when reading the flash memory can be reduced by setting the FMR27 bit in the FMR2 register to 1 (low-current-consumption read mode enabled).

When the CPU clock is set to the low-speed on-chip oscillator clock divided by 4, 8, or 16, low-current-consumption read mode can be used. When divided by 1 (no division) or divided by 2 is set, do not use low-current-consumption read mode.

After setting the divide ratio of the CPU clock, set the FMR27 bit to 1 (low-current-consumption read mode enabled).

To reduce the power consumption, refer to **29. Reducing Power Consumption**.

Enter wait mode or stop mode after setting the FMR27 bit to 0 (low-current-consumption read mode disabled).

Do not enter wait mode or stop mode while the FMR27 bit is 1 (low-current-consumption read mode enabled).

31.15 Notes on Noise

31.15.1 Inserting a Bypass Capacitor between VCC and VSS Pins as a Countermeasure against Noise and Latch-up

Connect a bypass capacitor (at least 0.1 μF) using the shortest and thickest wire possible.

31.15.2 Countermeasures against Noise Error of Port Control Registers

During rigorous noise testing or the like, external noise (mainly power supply system noise) can exceed the capacity of the MCU's internal noise control circuitry. In such cases the contents of the port related registers may be changed.

As a firmware countermeasure, it is recommended that the port registers, port direction registers, and pull-up control registers be reset periodically. However, examine the control processing fully before introducing the reset routine as conflicts may be created between the reset routine and interrupt routines.

31.16 Note on Supply Voltage Fluctuation

After reset is deasserted, the supply voltage applied to the VCC pin must meet either or both the allowable ripple voltage $V_r(\text{vcc})$ or ripple voltage falling gradient $dV_r(\text{vcc})/dt$ shown in Figure 31.6.

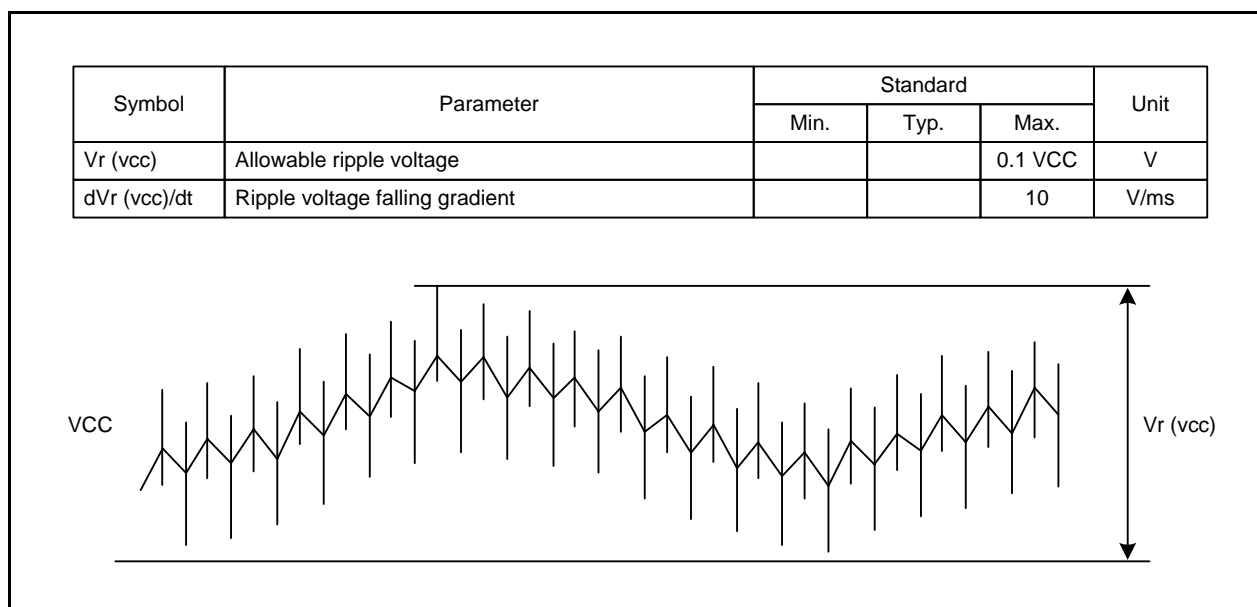

Figure 31.6 Definition of ripple voltage

32. Notes on On-Chip Debugger

When using the on-chip debugger to develop and debug programs for the R8C/33G Group, R8C/33H Group, take note of the following.

- (1) Some of the user flash memory and RAM areas are used by the on-chip debugger. These areas cannot be accessed by the user.
Refer to the on-chip debugger manual for which areas are used.
- (2) Do not set the address match interrupt (registers AIER0, AIER1, RMAD0, and RMAD1 and fixed vector tables) in a user system.
- (3) Do not use the BRK instruction in a user system.

Connecting and using the on-chip debugger has some special restrictions. Refer to the on-chip debugger manual for details.

33. Notes on Emulator Debugger

Connecting and using the emulator debugger has some special restrictions. Refer to the emulator debugger manual for details.

Note

Timer RD in these products does not support full-spec emulators. Use the on-chip debugging emulator for debugging.

Appendix 1. Package Dimensions

Diagrams showing the latest package dimensions and mounting information are available in the “Packages” section of the Renesas Electronics website.

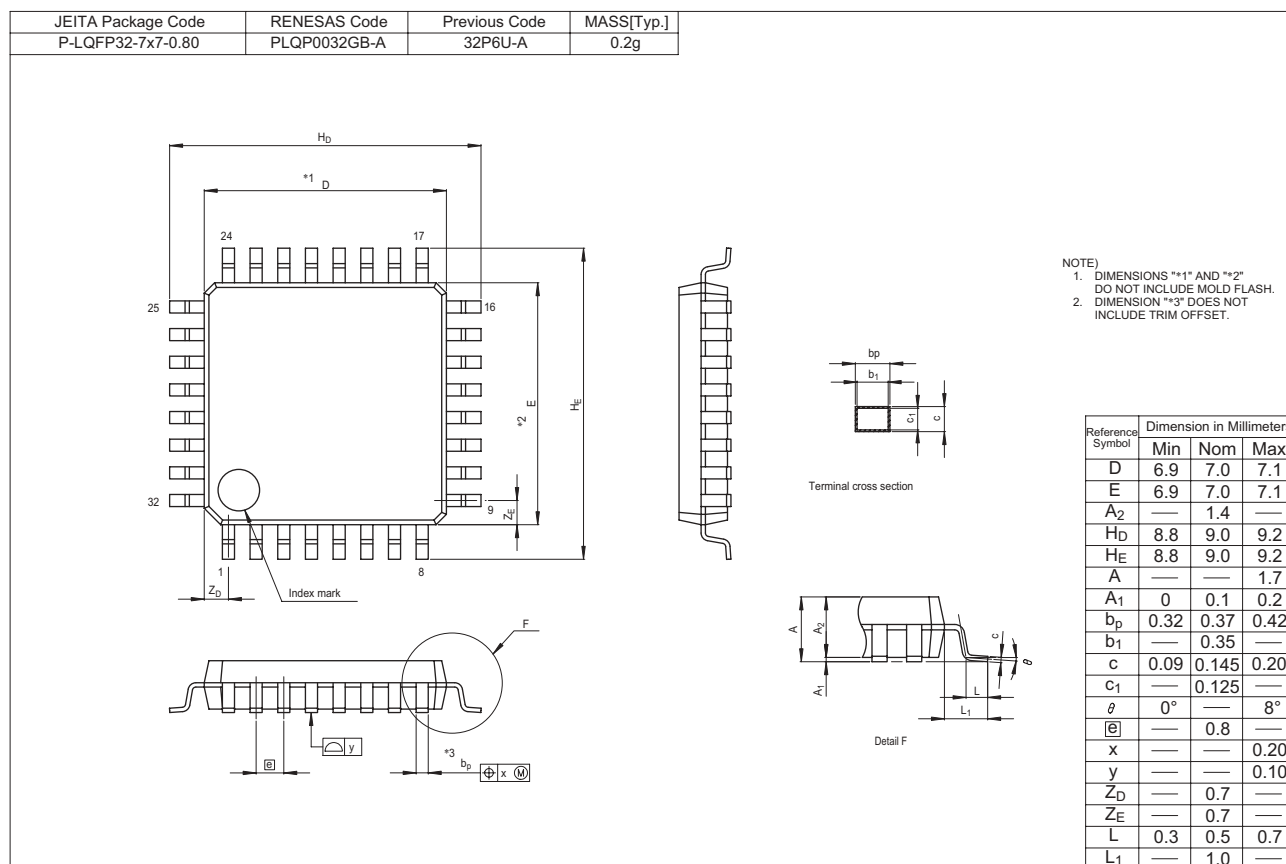

Appendix 2. Connection Examples between Serial Programmer and On-Chip Debugging Emulator

Appendix Figure 2.1 shows a Connection Example with MF Ten Nine Cable (M3A-0652CBL) and Appendix Figure 2.2 shows a Connection Example with E8a Emulator (R0E00008AKCE00).

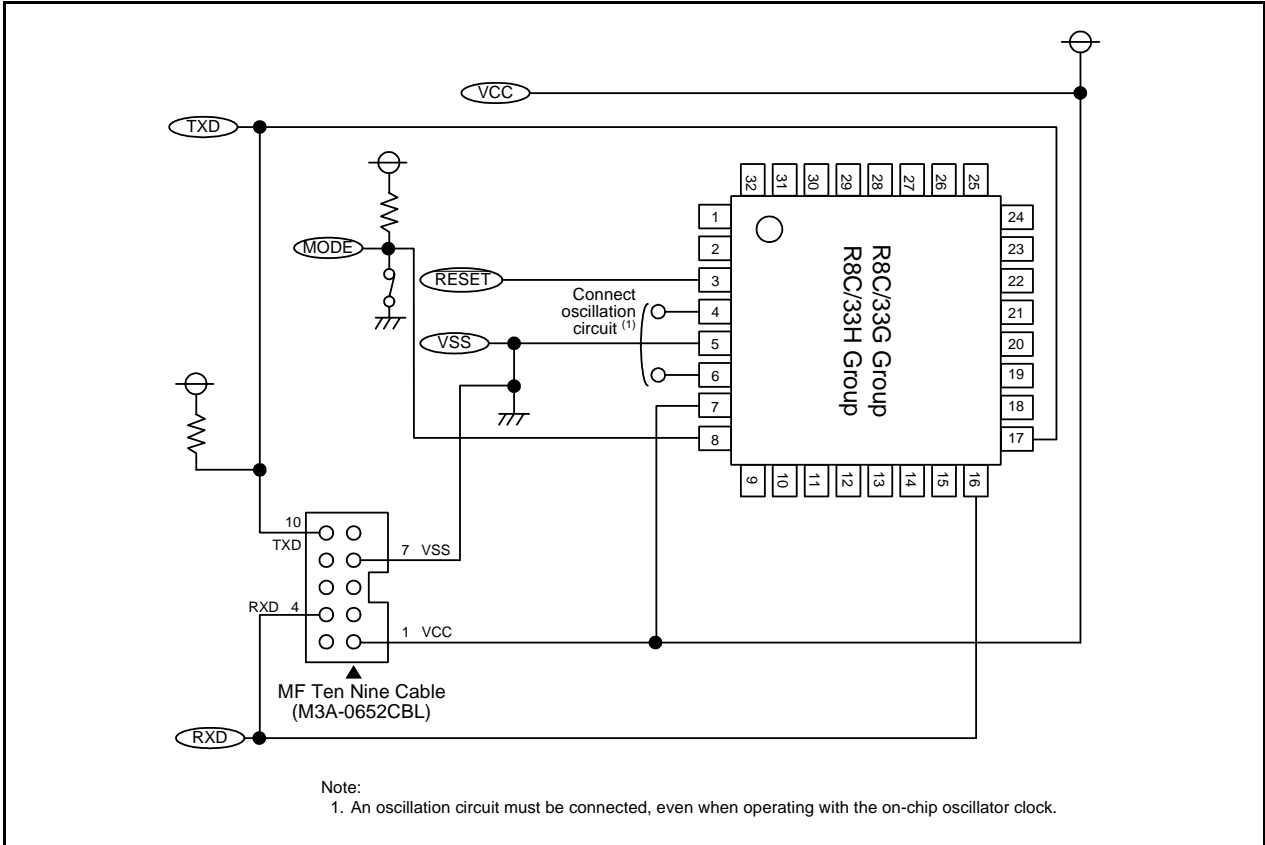

Appendix Figure 2.1 Connection Example with MF Ten Nine Cable (M3A-0652CBL)

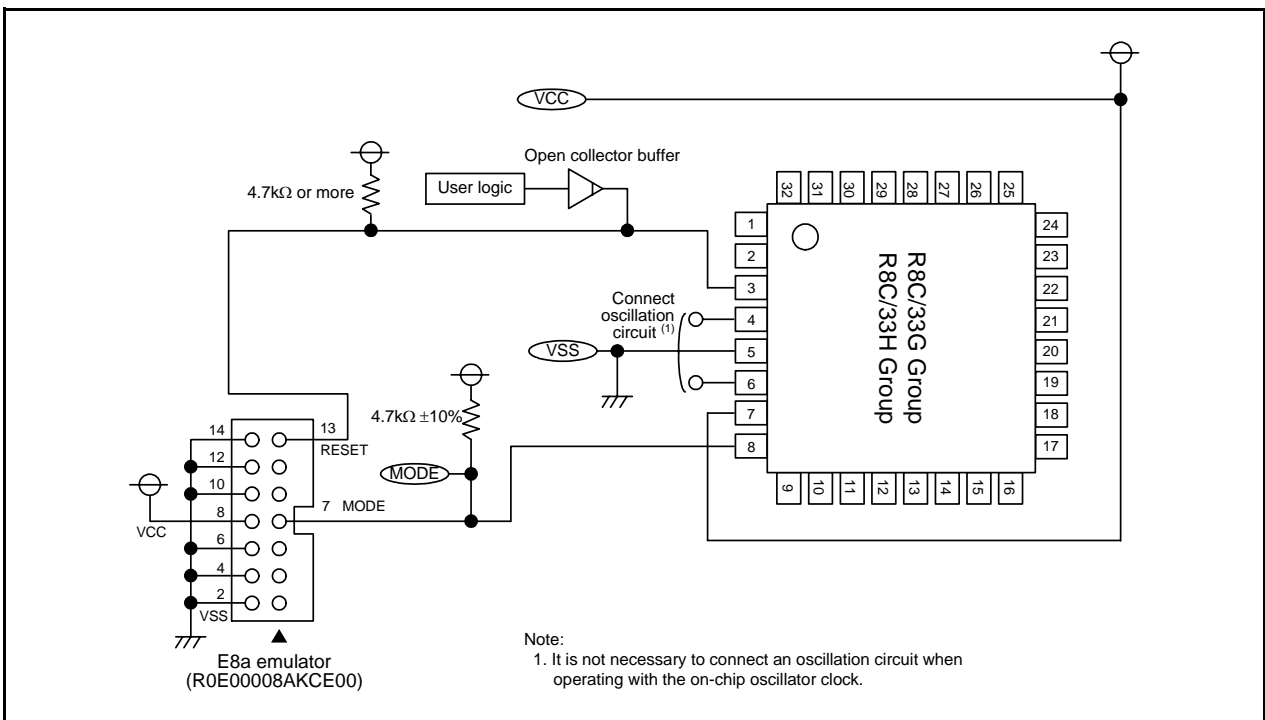

Appendix Figure 2.2 Connection Example with E8a Emulator (R0E00008AKCE00)

Appendix 3. Example of Oscillation Evaluation Circuit

Appendix Figure 3.1 shows an Example of Oscillation Evaluation Circuit.

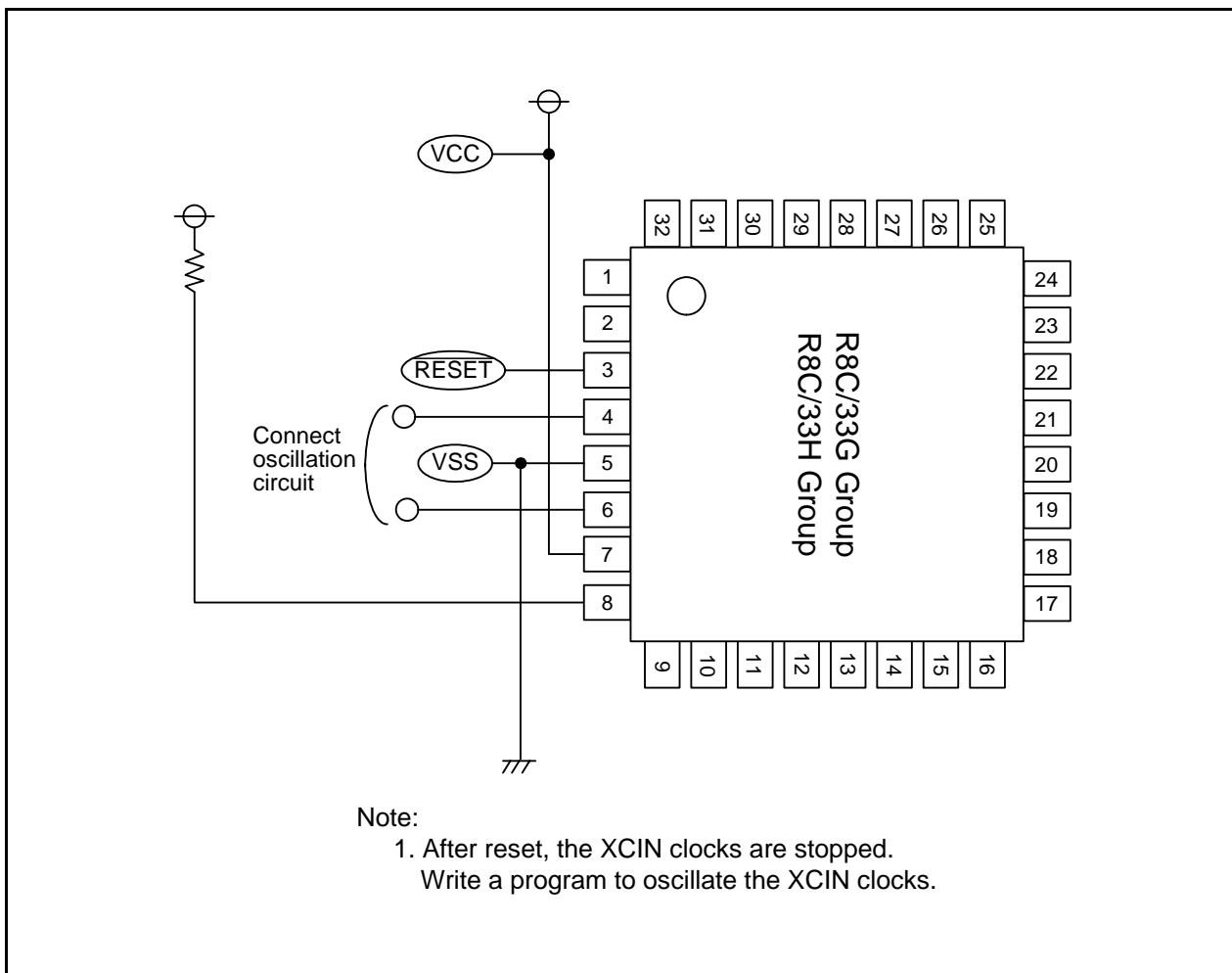

Appendix Figure 3.1 Example of Oscillation Evaluation Circuit

Index

[A]		[O]	
ADCON0	519	OCD	110
ADCON1	520	OCVREFCR	515
ADi (i = 0 to 7)	516	OFS	33, 52, 168, 175, 551
ADIC	140	OFS2	34, 169, 176
ADINSEL	518		
ADMOD	517	[P]	
AIERi (i = 0 or 1)	157	PDi (i = 0 to 1, 3 to 5)	71
		Pi (i = 0 to 1, 3 to 5)	72
[C]		PINSR	81
CM0	106	PM0	32
CM1	107	PM1	173
CM3	108	PRCR	134
CMPA	45	PUR0	82
CSPR	174	PUR1	82
[D]		[R]	
DACON	539	RMADi (i = 0 or 1)	157
DAi (i = 0 or 1)	539	RSTFR	32
DTBLSj (j = 0 to 23)	182		
DTCCRj (j = 0 to 23)	182	[S]	
DTCCTj (j = 0 to 23)	183	S0RIC	140
DTCENi (i = 0 to 4, 6)	184	S0TIC	140
DTCTL	185	S2RIC	140
DTDARj (j = 0 to 23)	183	S2TIC	140
DTRLDj (j = 0 to 23)	183	SSBR	472
DTSARj (j = 0 to 23)	183	SSCRH	473
		SSCRL	474
		SSER	476
[F]		SSMR	475
FMR0	555	SSMR2	478
FMR1	558, 560	SSRDR	473
FMR2	561, 563	SSSR	477
FMRDYIC	141	SSTDR	472
FRA0	111	SSUIC	141
FRA1	111	SSUICSR	79, 471
FRA2	112		
FRA3	113	[T]	
FRA4	113	TRA	205
FRA5	113	TRACR	203
FRA6	113	TRAIC	140
FRA7	110	TRAIOC	203, 206, 209, 211, 213, 216
FST	553	TRAMR	204
		TRAPRE	204
		TRASR	73, 205
[I]		TRBCR	220
INTCMP	542	TRBIC	140
INTEN	151, 542	TRBIOC	221, 224, 228, 231, 235
INTF	152, 543	TRBMR	221
INTiIC (i = 0 to 4)	142	TRBOCR	220
INTSR	80, 150	TRBPR	223
		TRBPPE	222
[K]		TRBRCSR	73, 223, 249
KIEN	155	TRBSC	222
KUPIC	140	TRC	246
		TRCADCR	248
[L]		TRCCR1	243, 265, 274, 280
LINCR	501	TRCCR2	247, 268, 275, 281
LINCR2	500	TRCDF	247, 282
LINST	501	TRCGRA	246
		TRCGRB	246
		TRCGRC	246
[M]		TRCGRD	246
MSTCR	242, 299, 313, 333, 348, 362, 378, 470		

TRCIC	141	VCAC	46
TRCIER	243	VCMP1IC	140
TRCIOR0	245, 260, 266	VCMP2IC	140
TRCIOR1	245, 261, 267	VD1LS	48
TRCMR	242	VLT0	83
TRCOER	248	VLT1	84
TRCPSR0	74, 250	VW0C	49
TRCPSR1	75, 251	VW1C	50
TRCSR	244	VW2C	51
TRD0	355, 369, 386		
TRD0IC	141	[W]	
TRD1	370	WDTC	174
TRD1IC	141	WDTR	173
TRDADCR	314, 334, 349, 363, 379	WDTS	173
TRDCR0	353, 384		
TRDCRi (i = 0 or 1)	302, 320, 338, 367		
TRDDFi (i = 0 or 1)	301		
TRDFCR	301, 317, 336, 351, 365, 381		
TRDGRAi (i = 0 or 1)	307, 325, 341, 356, 370, 387		
TRDGRBi (i = 0 or 1)	307, 325, 341, 356, 370, 387		
TRDGRC1	370		
TRDGRCi (i = 0 or 1)	307, 325, 341, 356, 387		
TRDGRDi (i = 0 or 1)	307, 325, 341, 356, 370, 387		
TRDi (i = 0 or 1)	306, 324, 341		
TRDIERi (i = 0 or 1)	306, 324, 340, 355, 369, 386		
TRDIORAi (i = 0 or 1)	303, 321		
TRDIORCi (i = 0 or 1)	304, 322		
TRDMR	300, 316, 335, 350, 364, 380		
TRDOCR	319, 338, 383		
TRDOER1	318, 337, 352, 366, 382		
TRDOER2	318, 337, 352, 366, 382		
TRDPMR	300, 317, 336		
TRDPOCRi (i = 0 or 1)	340		
TRDPSR0	76, 308, 326, 342, 357, 372, 389		
TRDPSR1	76, 308, 326, 342, 357, 372, 389		
TRDSRi (i = 0 or 1)	305, 323, 339, 354, 368, 385		
TRDSTR	299, 315, 335, 350, 364, 380		
[U]			
U0BRG	401		
U0C0	403		
U0C1	403		
U0MR	401		
U0RB	404		
U0SR	77, 405		
U0TB	402		
U2BCNIC	140		
U2BRG	423		
U2C0	425		
U2C1	426		
U2MR	423		
U2RB	427		
U2SMR	430		
U2SMR2	430		
U2SMR3	429		
U2SMR4	429		
U2SMR5	428		
U2SR0	78, 431		
U2SR1	78, 431		
U2TB	424		
URXDF	428		
[V]			
VCA1	46		
VCA2	47, 114		

REVISION HISTORY

R8C/33G Group, R8C/33H Group User's Manual: Hardware

Rev.	Date	Description	
		Page	Summary
0.10	Jan 29, 2010	—	First Edition issued
0.20	Jul 21, 2010	348 362 394, 623 510 518 519 592 636	Table 20.11 "Count stop conditions" revised Table 20.13 "Count stop conditions" revised Table 20.18 and 31.1 revised Table 25.1 "Conversion rate per pin" and "Note 3" revised Figure 25.2 and 25.3 revised Table 25.3 "A/D conversion execution time" revised Table 30.3 "tCONV Conversion time" revised 31.16 and Figure 31.6 added
1.00	Jul 05, 2011	All pages 3 5 6, 7 8 11 16 26 36 38 41 47 55 56 57 59 71 72 73 74 75 76 79 80 81 85 86 87 88 89	"Preliminary" and "Under development" deleted Table 1.2 revised Table 1.4 revised Table 1.5, Table 1.6 "(D): Under development" deleted, Figure 1.1, Figure 1.2 revised Figure 1.3 revised Table 1.8 revised 3.1 revised Table 4.9 revised Figure 5.4, Figure 5.5 revised 5.4 revised 6.1 revised 6.2.4 Note 1 revised Table 6.2 Note 3 revised Figure 6.6 revised Table 6.3 Note 3 revised Table 7.1, Table 7.2 Note1 revised 7.4.1 Note 2, Note3 revised 7.4.2 Note1, Note 2 revised 7.4.3, 7.4.4 revised 7.4.5 revised 7.4.6 revised 7.4.7 revised 7.4.12 revised 7.4.13 revised 7.4.14 revised Table 7.5 Note 2 added Table 7.10 revised, Note 2 added Table 7.13, Table 7.14 revised Table 7.15 revised Table 7.16 revised, Note 2 added

REVISION HISTORY

R8C/33G Group, R8C/33H Group User's Manual: Hardware

Rev.	Date	Description	
		Page	Summary
1.00	Jul 05, 2011	90	Table 7.18 revised
		91	Table 7.19 to Table 7.21 revised, Table 7.19 Note 2, Table 7.21 Note 2 added
		92	Table 7.22, Note 2, Table 7.23, Note 2 revised, Table 7.23 Note 3 deleted
		93	Table 7.24, Table 7.25 revised, Table 7.25 Note 2 added
		94	Table 7.26, Table 7.28 revised
		95	Table 7.29, Table 7.30 revised, Table 7.30 Note 2 deleted
		96	Table 7.31, Table 7.32, Note 1, Table 7.34 revised
		102	"To use the data flash with the data flash area.", Table 8.3 added
		103	9.1, Table 9.1 Note 3 revised
		105	Figure 9.2 " $\overline{\text{INT0}}$ " → "INT"
		108	9.2.3 Note 4 revised
		110	9.2.4 Note 4 "In addition, ... XIN clock oscillation is stable." added
		111	9.2.6 Note 3 added
		114	9.2.13 Note 1 revised
		114	"9.2.14 I/O Function Pin Select Register (PINSR)" deleted
		115	Figure 9.3 revised
		117	9.5.4 revised
		121	9.6.2.2 revised, 9.6.2.3 added
		122	Table 9.3 revised
		123	9.6.2.6 Title added
		124	9.6.2.7 Title added
		125	9.6.3.2 revised
		130	Figure 9.8 Title "when Oscillation Stop is Detected" added
		132	9.8.2 revised
		133	9.8.3, 9.8.4 "In addition, the XIN clock oscillation is stable." added
		138	Table 11.1 revised, Note 2 and Note 3 added
		139	Table 11.2 Note 3 and Note 4 added
		150	11.4.2 revised
		203	17.2.1, Note 4 revised
		205	17.2.5 Note 2 added, 17.2.6 revised
206	17.3.1 revised		
209	17.4.1 revised, Note 1 added		
211	17.5.1 revised		
213	17.6.1 revised		
216	17.7.1 revised		
218	17.8 "• Do not set 00h to pulse period measurement mode." added		
223	18.2.8 revised		
242	19.2.1, Note 1, Note 2, Note 4 revised		
249	19.2.14 revised		

REVISION HISTORY

R8C/33G Group, R8C/33H Group User's Manual: Hardware

Rev.	Date	Description	
		Page	Summary
1.00	Jul 05, 2011	250	19.2.15 revised
		251	19.2.16 revised
		258	Table 19.7 revised
		287, 288	19.9.4, 19.9.5 revised
		297	20.3 "Input Capture Function" → "Timer Mode (Input Capture Function)"
		299	20.3.1, Note1, Note 2, Note 4 revised,
		299 to 307	20.3.2 to 20.3.13 "... in Input Capture Function" → "... [Timer Mode (in Input Capture Function)]"
		308	20.3.14 revised
		311	20.4 "Output Compare Function" → "Timer Mode (Output Compare Function)"
		313	20.4.1, Note1, Note 2, Note4 revised
		315 to 325	20.4.3 to 20.4.16 "... in Output Compare Function" → "... [Timer Mode (in Output Compare Function)]"
		326	20.4.17, 20.4.18 revised
		333	20.5.1, Note 1, Note 2, Note4 revised
		342	20.5.16 revised
		348	20.6.1, Note 1, Note 2, Note 4 revised
		357	20.6.13 revised
		362	20.7.1, Note 1, Note 2, Note 4 revised
		372	20.7.14 revised
		378	20.8.1, Note 1, Note 2, Note 4 revised
		389	20.8.14 revised
		394	20.10.5, 20.10.6 revised
		396	Figure 20.26 revised
		407	Table 21.3 Note 2 deleted
		408	"Table 21.4 lists the I/O high-impedance state.)", Table 21.4 added
		413	Table 21.5 Note 1 "The IR bit in ... remains unchanged." deleted
		414	Table 21.6 Note 3 deleted
		415	"Table 21.7 lists the I/O high-impedance state.)", Table 21.7 added
		416	Figure 21.6 revised
		422	Table 22.1 revised
		423	22.2.2 revised
		424	22.2.3, Note 1 revised, Note 2 added
		433	Table 22.3 Note 2 deleted
		434	"Table 22.4 lists the Pin Serial I/O Mode.", Table 22.4 added
		439	Table 22.5 Note 1 "The IR bit in ... remains unchanged." deleted
		441	"Table 22.7 lists the I/O Pin in UART Mode.", Table 22.7 added
		446	22.4.6 "The output level edge of the CLK2 pin." deleted
		462	22.7.1, Figure 22.20 revised
		467	22.8.3, 22.8.4 added

REVISION HISTORY

R8C/33G Group, R8C/33H Group User's Manual: Hardware

Rev.	Date	Description	
		Page	Summary
1.00	Jul 05, 2011	470	23.2.1, Note 1, Note 2, Note 4 revised
		477	23.2.10 Note 5 "When reading ... used for writing and reading." added
		513	Table 25.1 revised
		520	25.2.6, Note 4, Note 5 and Note 6 added
		521	Figure 25.2, Figure 25.3 revised
		522	25.3.2 revised
		525	25.3.6 "Extended Analog Input Pins" → "On-Chip Reference Voltage (OCVREF)"
		535	25.9 "0.75" → "0.8", "3.5" → "4.4"
		552	Table 28.4 revised
		553	28.4.1 Note 1, Note 2 revised
		554	FST5 Bit revised
		556	CMDRST Bit revised, CMDERIE Bit "To change the CMDERIE bit ... as follows: (1) ... (2) ..." added
		557	BSYAEIE Bit "To change the BSYAEIE bit ... as follows: (1) ... (3) ..." and RDYSTIE Bit "To change the RDYSTIE bit ... as follows: (1) ... (3) ..." added
		567	Figure 28.4 revised
		570	28.4.13.1 revised
		571	28.4.13.3 revised
		578	28.4.13.6 revised
		579	Figure 28.15 revised
		583	Table 28.8, Figure 28.17 revised
		589	"28.7.1.8 Note when data flash is used" added
		590	29.2.3 revised
		591	29.2.9, Figure 29.1 added
		592	Figure 29.2 Title revised
		595	Table 30.1 revised, Note 1 to Note 4 added
		597	"Table 30.3 Recommended Operating Conditions (2)" added, Figure 30.1 revised
		598	Table 30.4 revised, Note 4 added
		600	Table 30.7, Note 1, Note 2 revised, Note 8 added
		601	Table 30.8 revised, Note 8 added
		602	Table 30.9, Table 30.10 revised
		603	Table 30.11 revised
		604	Table 30.13, Table 30.14 revised, Table 30.13 Note 2 added
		605	Table 30.16 revised
609	Table 30.17 revised		
610	Table 30.18 revised, Note 1 added		
611	Table 30.19 added		
612	"Timing Requirements" revised		

REVISION HISTORY

R8C/33G Group, R8C/33H Group User's Manual: Hardware

Rev.	Date	Description	
		Page	Summary
1.00	Jul 05, 2011	613	Table 30.22 revised
		614	Table 30.24 revised
		615	Table 30.25 revised, Note 1 added
		616	Table 30.26 added
		617	"Timing Requirements" revised
		618	Table 30.29 revised
		619	31.1.2 revised
		620	31.1.3, 31.1.4 "In addition, the XIN clock oscillation is stable." added
		629, 630	31.8.4, 31.8.5 revised
		632	31.9.6 revised
		634	Figure 31.3 revised
		639	31.11.3, 31.11.4 added
		643	31.14.1.8 added
648	Appendix Figure 2.1 revised		
1.10	Jan 31, 2014	61	Figure 7.1 revised
		62	Figure 7.3 revised
		63	Figure 7.4 revised
		64	Figure 7.5 revised
		65	Figure 7.6 revised
		66	Figure 7.7 revised
		67	Figure 7.8 revised
		68	Figure 7.10 revised
		70	Figure 7.12 revised
		91	Table 7.20 revised
		92	Table 7.22 revised
		119	9.6.1 revised
		125	9.6.3.2 revised
		196	15.3.8 revised
		200, 625	15.4.2, 31.5.2, revised, 15.4.5, 15.4.6, 31.5.5, 31.5.6 added
		203	17.2.1 revised
		218, 626	17.8, 31.6 revised
		396, 634	Figure 20.26, Figure 31.3 revised
		445	Figure 22.10 revised
		453	Figure 22.15 revised
		503	Figure 24.3 revised
		506	Figure 24.6 revised
		520	25.2.6 revised
531	Table 25.7 revised		
544	Figure 27.2 revised		
545	Figure 27.4 revised		

REVISION HISTORY	R8C/33G Group, R8C/33H Group User's Manual: Hardware
------------------	--

Rev.	Date	Description	
		Page	Summary
1.10	Jan 31, 2014	553, 554	28.4.1 revised
		556	28.4.2 revised
		566	Table 28.5 revised
		570	Table 28.6, 28.4.13.1 revised
		573	28.4.13.4 revised
		574	Figure 28.10 revised
		575	Figure 28.11 revised
		576	Figure 28.12 revised
		577	Figure 28.13 added
		—	28.4.13.7 deleted
		580	Table 28.7 revised
		581	Figure 28.16 revised
		589, 643	Old 28.7.1.7, 31.14.1.7 Block Blank Check deleted

R8C/33G Group, R8C/33H Group User's Manual: Hardware

Publication Date: Rev.0.10 Jan 29, 2010
Rev.1.10 Jan 31, 2014

Published by: Renesas Electronics Corporation

**SALES OFFICES****Renesas Electronics Corporation**<http://www.renesas.com>Refer to "<http://www.renesas.com/>" for the latest and detailed information.**Renesas Electronics America Inc.**2801 Scott Boulevard Santa Clara, CA 95050-2549, U.S.A.
Tel: +1-408-588-6000, Fax: +1-408-588-6130**Renesas Electronics Canada Limited**1101 Nicholson Road, Newmarket, Ontario L3Y 9C3, Canada
Tel: +1-905-898-5441, Fax: +1-905-898-3220**Renesas Electronics Europe Limited**Dukes Meadow, Millboard Road, Bourne End, Buckinghamshire, SL8 5FH, U.K
Tel: +44-1628-585-100, Fax: +44-1628-585-900**Renesas Electronics Europe GmbH**Arcadiastrasse 10, 40472 Düsseldorf, Germany
Tel: +49-211-6503-0, Fax: +49-211-6503-1327**Renesas Electronics (China) Co., Ltd.**Room 1709, Quantum Plaza, No.27 ZhiChunLu Haidian District, Beijing 100191, P.R.China
Tel: +86-10-8235-1155, Fax: +86-10-8235-7679**Renesas Electronics (Shanghai) Co., Ltd.**Unit 301, Tower A, Central Towers, 555 Langao Road, Putuo District, Shanghai, P. R. China 200333
Tel: +86-21-2226-0888, Fax: +86-21-2226-0999**Renesas Electronics Hong Kong Limited**Unit 1601-1613, 16/F., Tower 2, Grand Century Place, 193 Prince Edward Road West, Mongkok, Kowloon, Hong Kong
Tel: +852-2265-6688, Fax: +852 2686-9022/9044**Renesas Electronics Taiwan Co., Ltd.**13F, No. 363, Fu Shing North Road, Taipei 10543, Taiwan
Tel: +886-2-8175-9600, Fax: +886 2-8175-9670**Renesas Electronics Singapore Pte. Ltd.**80 Bendemeer Road, Unit #06-02 Hyflux Innovation Centre, Singapore 339949
Tel: +65-6213-0200, Fax: +65-6213-0300**Renesas Electronics Malaysia Sdn.Bhd.**Unit 906, Block B, Menara Amcorp, Amcorp Trade Centre, No. 18, Jln Persiaran Barat, 46050 Petaling Jaya, Selangor Darul Ehsan, Malaysia
Tel: +60-3-7955-9390, Fax: +60-3-7955-9510**Renesas Electronics Korea Co., Ltd.**12F., 234 Teheran-ro, Gangnam-Ku, Seoul, 135-920, Korea
Tel: +82-2-558-3737, Fax: +82-2-558-5141

R8C/33G Group, R8C/33H Group