

K40 Sub-Family Reference Manual

Supports: MK40DN512ZVLL10



Document Number: K40P100M100SF2RM
Rev. 6, Nov 2011



Contents

Section Number	Title	Page
----------------	-------	------

Chapter 1 About This Document

1.1	Overview.....	53
1.1.1	Purpose.....	53
1.1.2	Audience.....	53
1.2	Conventions.....	53
1.2.1	Numbering systems.....	53
1.2.2	Typographic notation.....	54
1.2.3	Special terms.....	54

Chapter 2 Introduction

2.1	Overview.....	55
2.2	K40 Family Introduction.....	55
2.3	Module Functional Categories.....	55
2.3.1	ARM Cortex-M4 Core Modules.....	56
2.3.2	System Modules.....	57
2.3.3	Memories and Memory Interfaces.....	58
2.3.4	Clocks.....	59
2.3.5	Security and Integrity modules.....	59
2.3.6	Analog modules.....	59
2.3.7	Timer modules.....	60
2.3.8	Communication interfaces.....	61
2.3.9	Human-machine interfaces.....	62
2.4	Orderable part numbers.....	62

Chapter 3 Chip Configuration

3.1	Introduction.....	65
-----	-------------------	----

Section Number	Title	Page
3.2	Core modules.....	65
3.2.1	ARM Cortex-M4 Core Configuration.....	65
3.2.2	Nested Vectored Interrupt Controller (NVIC) Configuration.....	68
3.2.3	Asynchronous Wake-up Interrupt Controller (AWIC) Configuration.....	74
3.2.4	JTAG Controller Configuration.....	75
3.3	System modules.....	76
3.3.1	SIM Configuration.....	76
3.3.2	Mode Controller Configuration.....	77
3.3.3	PMC Configuration.....	77
3.3.4	Low-Leakage Wake-up Unit (LLWU) Configuration.....	78
3.3.5	MCM Configuration.....	80
3.3.6	Crossbar Switch Configuration.....	80
3.3.7	Memory Protection Unit (MPU) Configuration.....	82
3.3.8	Peripheral Bridge Configuration.....	85
3.3.9	DMA request multiplexer configuration.....	87
3.3.10	DMA Controller Configuration.....	90
3.3.11	External Watchdog Monitor (EWM) Configuration.....	91
3.3.12	Watchdog Configuration.....	92
3.4	Clock Modules.....	93
3.4.1	MCG Configuration.....	93
3.4.2	OSC Configuration.....	94
3.4.3	RTC OSC configuration.....	95
3.5	Memories and Memory Interfaces.....	95
3.5.1	Flash Memory Configuration.....	95
3.5.2	Flash Memory Controller Configuration.....	98
3.5.3	SRAM Configuration.....	99
3.5.4	SRAM Controller Configuration.....	102

Section Number	Title	Page
3.5.5	System Register File Configuration.....	103
3.5.6	VBAT Register File Configuration.....	103
3.5.7	EzPort Configuration.....	104
3.6	Security.....	105
3.6.1	CRC Configuration.....	105
3.6.2	DryIce (tamper detect and secure storage) configuration.....	106

Section Number	Title	Page
3.7	Analog.....	107
3.7.1	16-bit SAR ADC with PGA Configuration.....	107
3.7.2	CMP Configuration.....	114
3.7.3	12-bit DAC Configuration.....	116
3.7.4	VREF Configuration.....	117
3.8	Timers.....	118
3.8.1	PDB Configuration.....	118
3.8.2	FlexTimer Configuration.....	121
3.8.3	PIT Configuration.....	125
3.8.4	Low-power timer configuration.....	126
3.8.5	CMT Configuration.....	128
3.8.6	RTC configuration.....	129
3.9	Communication interfaces.....	130
3.9.1	Universal Serial Bus (USB) Subsystem.....	130
3.9.2	CAN Configuration.....	135
3.9.3	SPI configuration.....	137
3.9.4	I2C Configuration.....	140
3.9.5	UART Configuration.....	141
3.9.6	SDHC Configuration.....	144
3.9.7	I2S configuration.....	145
3.10	Human-machine interfaces (HMI).....	147
3.10.1	GPIO configuration.....	147
3.10.2	TSI Configuration.....	148
3.10.3	Segment LCD Configuration.....	150
 Chapter 4 Memory Map 		
4.1	Introduction.....	153
4.2	System memory map.....	153
4.2.1	Aliased bit-band regions.....	154

Section Number	Title	Page
4.3	Flash Memory Map.....	155
4.3.1	Alternate Non-Volatile IRC User Trim Description.....	156
4.4	SRAM memory map.....	156
4.5	Peripheral bridge (AIPS-Lite0 and AIPS-Lite1) memory maps.....	156
4.5.1	Peripheral Bridge 0 (AIPS-Lite 0) Memory Map.....	157
4.5.2	Peripheral Bridge 1 (AIPS-Lite 1) Memory Map.....	161
4.6	Private Peripheral Bus (PPB) memory map.....	165

Chapter 5 Clock Distribution

5.1	Introduction.....	167
5.2	Programming model.....	167
5.3	High-Level device clocking diagram.....	167
5.4	Clock definitions.....	168
5.4.1	Device clock summary.....	169
5.5	Internal clocking requirements.....	171
5.5.1	Clock divider values after reset.....	171
5.5.2	VLPR mode clocking.....	172
5.6	Clock Gating.....	172
5.7	Module clocks.....	172
5.7.1	PMC 1-kHz LPO clock.....	174
5.7.2	WDOG clocking.....	174
5.7.3	Debug trace clock.....	175
5.7.4	PORT digital filter clocking.....	175
5.7.5	LPTMR clocking.....	176
5.7.6	USB FS OTG Controller clocking.....	176
5.7.7	FlexCAN clocking.....	177
5.7.8	UART clocking.....	177
5.7.9	SDHC clocking.....	177
5.7.10	I2S clocking.....	178

Section Number	Title	Page
5.7.11	TSI clocking.....	178

Chapter 6 Reset and Boot

6.1	Introduction.....	181
6.2	Reset.....	181
6.2.1	Power-on reset (POR).....	182
6.2.2	System resets.....	182
6.2.3	Debug resets.....	185
6.3	Boot.....	187
6.3.1	Boot sources.....	187
6.3.2	Boot options.....	187
6.3.3	FOPT boot options.....	187
6.3.4	Boot sequence.....	188

Chapter 7 Power Management

7.1	Introduction.....	191
7.2	Power modes.....	191
7.3	Entering and exiting power modes.....	193
7.4	Power mode transitions.....	194
7.5	Power modes shutdown sequencing.....	195
7.6	Module Operation in Low Power Modes.....	195
7.7	Clock Gating.....	198

Chapter 8 Security

8.1	Introduction.....	199
8.2	Flash Security.....	199
8.3	Security Interactions with other Modules.....	200
8.3.1	Security Interactions with EzPort.....	200
8.3.2	Security Interactions with Debug.....	200

Section Number	Title	Page
Chapter 9		
Debug		
9.1	Introduction.....	201
9.1.1	References.....	203
9.2	The Debug Port.....	203
9.2.1	JTAG-to-SWD change sequence.....	204
9.2.2	JTAG-to-cJTAG change sequence.....	204
9.3	Debug Port Pin Descriptions.....	205
9.4	System TAP connection.....	205
9.4.1	IR Codes.....	205
9.5	JTAG status and control registers.....	206
9.5.1	MDM-AP Control Register.....	207
9.5.2	MDM-AP Status Register.....	209
9.6	Debug Resets.....	210
9.7	AHB-AP.....	211
9.8	ITM.....	212
9.9	Core Trace Connectivity.....	212
9.10	Embedded Trace Macrocell v3.5 (ETM).....	212
9.11	Coresight Embedded Trace Buffer (ETB).....	213
9.11.1	Performance Profiling with the ETB.....	213
9.11.2	ETB Counter Control.....	214
9.12	TPIU.....	214
9.13	DWT.....	214
9.14	Debug in Low Power Modes.....	215
9.14.1	Debug Module State in Low Power Modes.....	216
9.15	Debug & Security.....	216

Chapter 10
Signal Multiplexing and Signal Descriptions

10.1	Introduction.....	217
------	-------------------	-----

Section Number	Title	Page
10.2	Signal Multiplexing Integration.....	217
10.2.1	Port control and interrupt module features.....	218
10.2.2	Clock gating.....	218
10.2.3	Signal multiplexing constraints.....	218
10.3	Pinout.....	219
10.3.1	K40 Signal Multiplexing and Pin Assignments.....	219
10.3.2	K40 Pinouts.....	223
10.4	Module Signal Description Tables.....	224
10.4.1	Core Modules.....	224
10.4.2	System Modules.....	225
10.4.3	Clock Modules.....	226
10.4.4	Memories and Memory Interfaces.....	226
10.4.5	Security Modules.....	227
10.4.6	Analog.....	227
10.4.7	Communication Interfaces.....	229
10.4.8	Human-Machine Interfaces (HMI).....	233

Chapter 11 Port control and interrupts (PORT)

11.1	Introduction.....	235
11.1.1	Overview.....	235
11.1.2	Features.....	235
11.1.3	Modes of operation.....	236
11.2	External signal description.....	237
11.3	Detailed signal descriptions.....	237
11.4	Memory map and register definition.....	237
11.4.1	Pin Control Register n (PORT _x _PCR _n).....	244
11.4.2	Global Pin Control Low Register (PORT _x _GPCLR).....	246
11.4.3	Global Pin Control High Register (PORT _x _GPCHR).....	247
11.4.4	Interrupt Status Flag Register (PORT _x _ISFR).....	247

Section Number	Title	Page
11.4.5	Digital Filter Enable Register (PORTx_DFER).....	248
11.4.6	Digital Filter Clock Register (PORTx_DFRCR).....	249
11.4.7	Digital Filter Width Register (PORTx_DFWR).....	249
11.5	Functional description.....	250
11.5.1	Pin control.....	250
11.5.2	Global pin control.....	250
11.5.3	External interrupts.....	251
11.5.4	Digital filter.....	252

Chapter 12 System integration module (SIM)

12.1	Introduction.....	253
12.1.1	Features.....	253
12.1.2	Modes of operation.....	253
12.1.3	SIM Signal Descriptions.....	254
12.2	Memory map and register definition.....	254
12.2.1	System Options Register 1 (SIM_SOPT1).....	256
12.2.2	System Options Register 2 (SIM_SOPT2).....	258
12.2.3	System Options Register 4 (SIM_SOPT4).....	260
12.2.4	System Options Register 5 (SIM_SOPT5).....	262
12.2.5	System Options Register 6 (SIM_SOPT6).....	264
12.2.6	System Options Register 7 (SIM_SOPT7).....	265
12.2.7	System Device Identification Register (SIM_SDID).....	267
12.2.8	System Clock Gating Control Register 1 (SIM_SCGC1).....	268
12.2.9	System Clock Gating Control Register 2 (SIM_SCGC2).....	269
12.2.10	System Clock Gating Control Register 3 (SIM_SCGC3).....	270
12.2.11	System Clock Gating Control Register 4 (SIM_SCGC4).....	271
12.2.12	System Clock Gating Control Register 5 (SIM_SCGC5).....	274
12.2.13	System Clock Gating Control Register 6 (SIM_SCGC6).....	276
12.2.14	System Clock Gating Control Register 7 (SIM_SCGC7).....	278

Section Number	Title	Page
12.2.15	System Clock Divider Register 1 (SIM_CLKDIV1).....	279
12.2.16	System Clock Divider Register 2 (SIM_CLKDIV2).....	281
12.2.17	Flash Configuration Register 1 (SIM_FCFG1).....	282
12.2.18	Flash Configuration Register 2 (SIM_FCFG2).....	284
12.2.19	Unique Identification Register High (SIM_UIDH).....	285
12.2.20	Unique Identification Register Mid-High (SIM_UIDMH).....	286
12.2.21	Unique Identification Register Mid Low (SIM_UIDML).....	286
12.2.22	Unique Identification Register Low (SIM_UIDL).....	287
12.3	Functional description.....	287

Chapter 13 Mode Controller

13.1	Introduction.....	289
13.1.1	Features.....	289
13.1.2	Modes of Operation.....	289
13.1.3	MCU Reset.....	300
13.2	Mode Control Memory Map/Register Definition.....	303
13.2.1	System Reset Status Register High (MC_SRSR).....	304
13.2.2	System Reset Status Register Low (MC_SRSL).....	305
13.2.3	Power Mode Protection Register (MC_PMPROT).....	306
13.2.4	Power Mode Control Register (MC_PMCTRL).....	308

Chapter 14 Power Management Controller

14.1	Introduction.....	311
14.2	Features.....	311
14.3	Low-Voltage Detect (LVD) System.....	311
14.3.1	LVD Reset Operation.....	312
14.3.2	LVD Interrupt Operation.....	312
14.3.3	Low-Voltage Warning (LVW) Interrupt Operation.....	312

Section Number	Title	Page
14.4	PMC Memory Map/Register Definition.....	313
14.4.1	Low Voltage Detect Status and Control 1 Register (PMC_LVDSC1).....	313
14.4.2	Low Voltage Detect Status and Control 2 Register (PMC_LVDSC2).....	314
14.4.3	Regulator Status and Control Register (PMC_REGSC).....	316

Chapter 15 Low-leakage wake-up unit (LLWU)

15.1	Introduction.....	317
15.1.1	Features.....	318
15.1.2	Modes of operation.....	318
15.1.3	Block diagram.....	319
15.2	LLWU Signal Descriptions.....	320
15.3	Memory map/register definition.....	321
15.3.1	LLWU Pin Enable 1 Register (LLWU_PE1).....	321
15.3.2	LLWU Pin Enable 2 Register (LLWU_PE2).....	322
15.3.3	LLWU Pin Enable 3 Register (LLWU_PE3).....	324
15.3.4	LLWU Pin Enable 4 Register (LLWU_PE4).....	325
15.3.5	LLWU Module Enable Register (LLWU_ME).....	326
15.3.6	LLWU Flag 1 Register (LLWU_F1).....	327
15.3.7	LLWU Flag 2 Register (LLWU_F2).....	329
15.3.8	LLWU Flag 3 Register (LLWU_F3).....	331
15.3.9	LLWU Control and Status Register (LLWU_CS).....	332
15.4	Functional description.....	333
15.4.1	LLS mode.....	334
15.4.2	VLLS modes.....	334
15.4.3	Initialization.....	335
15.4.4	Low power mode recovery.....	335

Section Number	Title	Page
Chapter 16		
Miscellaneous Control Module (MCM)		
16.1	Introduction.....	337
16.1.1	Features.....	337
16.2	Memory Map/Register Descriptions.....	337
16.2.1	Crossbar switch (AXBS) slave configuration (MCM_PLASC).....	338
16.2.2	Crossbar switch (AXBS) master configuration (MCM_PLAMC).....	338
16.2.3	SRAM arbitration and protection (MCM_SRAMAP).....	339
16.2.4	Interrupt status register (MCM_ISR).....	340
16.2.5	ETB counter control register (MCM_ETBCC).....	341
16.2.6	ETB reload register (MCM_ETBRL).....	342
16.2.7	ETB counter value register (MCM_ETBCNT).....	343
16.3	Functional Description.....	343
16.3.1	Interrupts.....	343
Chapter 17		
Crossbar Switch (AXBS)		
17.1	Introduction.....	345
17.1.1	Features.....	345
17.2	Memory Map / Register Definition.....	346
17.2.1	Priority Registers Slave (AXBS_PRSn).....	347
17.2.2	Control Register (AXBS_CRSn).....	350
17.2.3	Master General Purpose Control Register (AXBS_MGPCRn).....	352
17.3	Functional Description.....	353
17.3.1	General operation.....	353
17.3.2	Register coherency.....	354
17.3.3	Arbitration.....	354
17.4	Initialization/application information.....	357
Chapter 18		
Memory Protection Unit (MPU)		
18.1	Introduction.....	359

Section Number	Title	Page
18.2	Overview.....	359
18.2.1	Block Diagram.....	359
18.2.2	Features.....	360
18.3	Memory Map/Register Definition.....	361
18.3.1	Control/Error Status Register (MPU_CESR).....	364
18.3.2	Error Address Register, Slave Port n (MPU_EARn).....	366
18.3.3	Error Detail Register, Slave Port n (MPU_EDRn).....	367
18.3.4	Region Descriptor n, Word 0 (MPU_RGDn_WORD0).....	368
18.3.5	Region Descriptor n, Word 1 (MPU_RGDn_WORD1).....	369
18.3.6	Region Descriptor n, Word 2 (MPU_RGDn_WORD2).....	369
18.3.7	Region Descriptor n, Word 3 (MPU_RGDn_WORD3).....	372
18.3.8	Region Descriptor Alternate Access Control n (MPU_RGDAACn).....	373
18.4	Functional Description.....	375
18.4.1	Access Evaluation Macro.....	375
18.4.2	Putting It All Together and Error Terminations.....	376
18.4.3	Power Management.....	377
18.5	Initialization Information.....	377
18.6	Application Information.....	377

Chapter 19 Peripheral Bridge (AIPS-Lite)

19.1	Introduction.....	381
19.1.1	Features.....	381
19.1.2	General operation.....	381
19.2	Memory map/register definition.....	382
19.2.1	Master Privilege Register A (AIPSx_MPRA).....	383
19.2.2	Peripheral Access Control Register (AIPSx_PACRn).....	387
19.2.3	Peripheral Access Control Register (AIPSx_PACRn).....	392
19.3	Functional Description.....	397
19.3.1	Access support.....	397

Section Number	Title	Page
Chapter 20		
Direct memory access multiplexer (DMAMUX)		
20.1	Introduction.....	399
20.1.1	Overview.....	399
20.1.2	Features.....	400
20.1.3	Modes of operation.....	400
20.2	External signal description.....	401
20.3	Memory map/register definition.....	401
20.3.1	Channel Configuration Register (DMAMUX_CHCFGn).....	402
20.4	Functional description.....	403
20.4.1	DMA channels with periodic triggering capability.....	403
20.4.2	DMA channels with no triggering capability.....	406
20.4.3	"Always enabled" DMA sources.....	406
20.5	Initialization/application information.....	407
20.5.1	Reset.....	407
20.5.2	Enabling and configuring sources.....	407
Chapter 21		
Direct Memory Access Controller (eDMA)		
21.1	Introduction.....	411
21.1.1	Block diagram.....	411
21.1.2	Block parts.....	412
21.1.3	Features.....	414
21.2	Modes of operation.....	415
21.3	Memory map/register definition.....	415
21.3.1	Control Register (DMA_CR).....	430
21.3.2	Error Status Register (DMA_ES).....	432
21.3.3	Enable Request Register (DMA_ERQ).....	434
21.3.4	Enable Error Interrupt Register (DMA_EEI).....	436
21.3.5	Clear Enable Error Interrupt Register (DMA_CEEI).....	438

Section Number	Title	Page
21.3.6	Set Enable Error Interrupt Register (DMA_SEEI).....	439
21.3.7	Clear Enable Request Register (DMA_CERQ).....	440
21.3.8	Set Enable Request Register (DMA_SERQ).....	441
21.3.9	Clear DONE Status Bit Register (DMA_CDNE).....	442
21.3.10	Set START Bit Register (DMA_SSRT).....	443
21.3.11	Clear Error Register (DMA_CERR).....	444
21.3.12	Clear Interrupt Request Register (DMA_CINT).....	445
21.3.13	Interrupt Request Register (DMA_INT).....	445
21.3.14	Error Register (DMA_ERR).....	448
21.3.15	Hardware Request Status Register (DMA_HRS).....	450
21.3.16	Channel n Priority Register (DMA_DCHPRIn).....	452
21.3.17	TCD Source Address (DMA_TCDn_SADDR).....	453
21.3.18	TCD Signed Source Address Offset (DMA_TCDn_SOFF).....	454
21.3.19	TCD Transfer Attributes (DMA_TCDn_ATTR).....	454
21.3.20	TCD Minor Byte Count (Minor Loop Disabled) (DMA_TCDn_NBYTES_MLNO).....	455
21.3.21	TCD Signed Minor Loop Offset (Minor Loop Enabled and Offset Disabled) (DMA_TCDn_NBYTES_MLOFFNO).....	456
21.3.22	TCD Signed Minor Loop Offset (Minor Loop and Offset Enabled) (DMA_TCDn_NBYTES_MLOFFYES).....	457
21.3.23	TCD Last Source Address Adjustment (DMA_TCDn_SLAST).....	458
21.3.24	TCD Destination Address (DMA_TCDn_DADDR).....	458
21.3.25	TCD Signed Destination Address Offset (DMA_TCDn_DOFF).....	459
21.3.26	TCD Current Minor Loop Link, Major Loop Count (Channel Linking Enabled) (DMA_TCDn_CITER_ELINKYES).....	459
21.3.27	TCD Current Minor Loop Link, Major Loop Count (Channel Linking Disabled) (DMA_TCDn_CITER_ELINKNO).....	460
21.3.28	TCD Last Destination Address Adjustment/Scatter Gather Address (DMA_TCDn_DLASTSGA).....	461
21.3.29	TCD Control and Status (DMA_TCDn_CSR).....	462
21.3.30	TCD Beginning Minor Loop Link, Major Loop Count (Channel Linking Enabled) (DMA_TCDn_BITER_ELINKYES).....	464

Section Number	Title	Page
21.3.31	TCD Beginning Minor Loop Link, Major Loop Count (Channel Linking Disabled) (DMA_TCDn_BITER_ELINKNO).....	465
21.4	Functional description.....	466
21.4.1	eDMA basic data flow.....	466
21.4.2	Error reporting and handling.....	469
21.4.3	Channel preemption.....	471
21.4.4	Performance.....	471
21.5	Initialization/application information.....	475
21.5.1	eDMA initialization.....	475
21.5.2	Programming errors.....	477
21.5.3	Arbitration mode considerations.....	478
21.5.4	Performing DMA transfers.....	478
21.5.5	Monitoring transfer descriptor status.....	482
21.5.6	Dynamic programming.....	484

Chapter 22 External Watchdog Monitor (EWM)

22.1	Introduction.....	487
22.1.1	Features.....	487
22.1.2	Modes of Operation.....	488
22.1.3	Block Diagram.....	489
22.2	EWM Signal Descriptions.....	490
22.3	Memory Map/Register Definition.....	490
22.3.1	Control Register (EWM_CTRL).....	490
22.3.2	Service Register (EWM_SERV).....	491
22.3.3	Compare Low Register (EWM_CMPL).....	492
22.3.4	Compare High Register (EWM_CMPH).....	492
22.4	Functional Description.....	493
22.4.1	The EWM_out Signal.....	493
22.4.2	The EWM_in Signal.....	494

Section Number	Title	Page
22.4.3	EWM Counter.....	494
22.4.4	EWM Compare Registers.....	494
22.4.5	EWM Refresh Mechanism.....	495

Chapter 23 Watchdog Timer (WDOG)

23.1	Introduction.....	497
23.2	Features.....	497
23.3	Functional Overview.....	499
23.3.1	Unlocking and Updating the Watchdog.....	500
23.3.2	The Watchdog Configuration Time (WCT).....	501
23.3.3	Refreshing the Watchdog.....	502
23.3.4	Windowed Mode of Operation.....	502
23.3.5	Watchdog Disabled Mode of Operation.....	502
23.3.6	Low Power Modes of Operation.....	503
23.3.7	Debug Modes of Operation.....	503
23.4	Testing the Watchdog.....	504
23.4.1	Quick Test.....	504
23.4.2	Byte Test.....	504
23.5	Backup Reset Generator.....	506
23.6	Generated Resets and Interrupts.....	506
23.7	Memory Map and Register Definition.....	507
23.7.1	Watchdog Status and Control Register High (WDOG_STCTRLH).....	508
23.7.2	Watchdog Status and Control Register Low (WDOG_STCTRL).....	510
23.7.3	Watchdog Time-out Value Register High (WDOG_TOVALH).....	510
23.7.4	Watchdog Time-out Value Register Low (WDOG_TOVAL).....	511
23.7.5	Watchdog Window Register High (WDOG_WINH).....	511
23.7.6	Watchdog Window Register Low (WDOG_WINL).....	512
23.7.7	Watchdog Refresh Register (WDOG_REFRESH).....	512
23.7.8	Watchdog Unlock Register (WDOG_UNLOCK).....	512

Section Number	Title	Page
23.7.9	Watchdog Timer Output Register High (WDOG_TMROUTH).....	513
23.7.10	Watchdog Timer Output Register Low (WDOG_TMROUTL).....	513
23.7.11	Watchdog Reset Count Register (WDOG_RSTCNT).....	514
23.7.12	Watchdog Prescaler Register (WDOG_PRESC).....	514
23.8	Watchdog Operation with 8-bit access.....	514
23.8.1	General Guideline.....	514
23.8.2	Refresh and Unlock operations with 8-bit access.....	515
23.9	Restrictions on Watchdog Operation.....	516

Chapter 24 Multipurpose Clock Generator (MCG)

24.1	Introduction.....	519
24.1.1	Features.....	519
24.1.2	Modes of Operation.....	522
24.2	External Signal Description.....	523
24.3	Memory Map/Register Definition.....	523
24.3.1	MCG Control 1 Register (MCG_C1).....	524
24.3.2	MCG Control 2 Register (MCG_C2).....	525
24.3.3	MCG Control 3 Register (MCG_C3).....	526
24.3.4	MCG Control 4 Register (MCG_C4).....	527
24.3.5	MCG Control 5 Register (MCG_C5).....	528
24.3.6	MCG Control 6 Register (MCG_C6).....	530
24.3.7	MCG Status Register (MCG_S).....	531
24.3.8	MCG Auto Trim Control Register (MCG_ATC).....	533
24.3.9	MCG Auto Trim Compare Value High Register (MCG_ATCVH).....	533
24.3.10	MCG Auto Trim Compare Value Low Register (MCG_ATCVL).....	534
24.4	Functional Description.....	534
24.4.1	MCG Mode State Diagram.....	534
24.4.2	Low Power Bit Usage.....	539

Section Number	Title	Page
24.4.3	MCG Internal Reference Clocks.....	539
24.4.4	External Reference Clock.....	540
24.4.5	MCG Fixed Frequency Clock	540
24.4.6	MCG PLL Clock	541
24.4.7	MCG Auto TRIM (ATM).....	541
24.5	Initialization / Application Information.....	542
24.5.1	MCG Module Initialization Sequence.....	542
24.5.2	Using a 32.768 kHz Reference.....	544
24.5.3	MCG Mode Switching.....	545

Chapter 25 Oscillator (OSC)

25.1	Introduction.....	555
25.2	Features and Modes.....	555
25.3	Block Diagram.....	556
25.4	OSC Signal Descriptions.....	556
25.5	External Crystal / Resonator Connections.....	557
25.6	External Clock Connections.....	558
25.7	Memory Map/Register Definitions.....	559
25.7.1	OSC Memory Map/Register Definition.....	559
25.8	Functional Description.....	560
25.8.1	OSC Module States.....	560
25.8.2	OSC Module Modes.....	562
25.8.3	Counter.....	564
25.8.4	Reference Clock Pin Requirements.....	564
25.9	Reset.....	564
25.10	Low Power Modes Operation.....	565
25.11	Interrupts.....	565

Section Number	Title	Page
Chapter 26		
RTC Oscillator		
26.1	Introduction.....	567
26.1.1	Features and Modes.....	567
26.1.2	Block Diagram.....	567
26.2	RTC Signal Descriptions.....	568
26.2.1	EXTAL32 — Oscillator Input.....	568
26.2.2	XTAL32 — Oscillator Output.....	568
26.3	External Crystal Connections.....	569
26.4	Memory Map/Register Descriptions.....	569
26.5	Functional Description.....	569
26.6	Reset Overview.....	570
26.7	Interrupts.....	570

Chapter 27
Flash Memory Controller (FMC)

27.1	Introduction.....	571
27.1.1	Overview.....	571
27.1.2	Features.....	571
27.2	Modes of operation.....	572
27.3	External signal description.....	572
27.4	Memory map and register descriptions.....	572
27.4.1	Flash Access Protection Register (FMC_PFAPR).....	579
27.4.2	Flash Bank 0 Control Register (FMC_PFB0CR).....	582
27.4.3	Flash Bank 1 Control Register (FMC_PFB1CR).....	584
27.4.4	Cache Tag Storage (FMC_TAGVDW0Sn).....	586
27.4.5	Cache Tag Storage (FMC_TAGVDW1Sn).....	587
27.4.6	Cache Tag Storage (FMC_TAGVDW2Sn).....	588
27.4.7	Cache Tag Storage (FMC_TAGVDW3Sn).....	589
27.4.8	Cache Data Storage (upper word) (FMC_DATAW0SnU).....	590

Section Number	Title	Page
27.4.9	Cache Data Storage (lower word) (FMC_DATAW0SnL).....	591
27.4.10	Cache Data Storage (upper word) (FMC_DATAW1SnU).....	592
27.4.11	Cache Data Storage (lower word) (FMC_DATAW1SnL).....	593
27.4.12	Cache Data Storage (upper word) (FMC_DATAW2SnU).....	594
27.4.13	Cache Data Storage (lower word) (FMC_DATAW2SnL).....	595
27.4.14	Cache Data Storage (upper word) (FMC_DATAW3SnU).....	596
27.4.15	Cache Data Storage (lower word) (FMC_DATAW3SnL).....	597
27.5	Functional description.....	597

Chapter 28 Flash Memory Module (FTFL)

28.1	Introduction.....	599
28.1.1	Features.....	600
28.1.2	Block Diagram.....	600
28.1.3	Glossary.....	601
28.2	External Signal Description.....	602
28.3	Memory Map and Registers.....	603
28.3.1	Flash Configuration Field Description.....	603
28.3.2	Program Flash IFR Map.....	603
28.3.3	Register Descriptions.....	604
28.4	Functional Description.....	613
28.4.1	Program Flash Memory Swap.....	613
28.4.2	Interrupts.....	614
28.4.3	Flash Operation in Low-Power Modes.....	614
28.4.4	Functional Modes of Operation.....	615
28.4.5	Flash Reads and Ignored Writes.....	615
28.4.6	Read While Write (RWW).....	615
28.4.7	Flash Program and Erase.....	615
28.4.8	FTFL Command Operations.....	616
28.4.9	Margin Read Commands.....	621

Section Number	Title	Page
28.4.10	FTFL Command Description.....	622
28.4.11	Security.....	644
28.4.12	Reset Sequence.....	646

Chapter 29 EzPort

29.1	Overview.....	647
29.1.1	Introduction.....	647
29.1.2	Features.....	648
29.1.3	Modes of Operation.....	648
29.2	External Signal Description.....	649
29.2.1	EzPort Clock (EZP_CK).....	649
29.2.2	EzPort Chip Select (EZP_CS).....	649
29.2.3	EzPort Serial Data In (EZP_D).....	650
29.2.4	EzPort Serial Data Out (EZP_Q).....	650
29.3	Command Definition.....	650
29.3.1	Command Descriptions.....	651
29.4	Flash Memory Map for EzPort Access.....	655

Chapter 30 Cyclic redundancy check (CRC)

30.1	Introduction.....	657
30.1.1	Features.....	657
30.1.2	Block diagram.....	657
30.1.3	Modes of operation.....	658
30.2	Memory map and register descriptions.....	658
30.2.1	CRC Data Register (CRC_CRC).....	659
30.2.2	CRC Polynomial Register (CRC_GPOLY).....	660
30.2.3	CRC Control Register (CRC_CTRL).....	661
30.3	Functional description.....	662
30.3.1	CRC initialization/re-initialization.....	662

Section Number	Title	Page
30.3.2	CRC calculations.....	662
30.3.3	Transpose feature.....	663
30.3.4	CRC result complement.....	665

Chapter 31 Analog-to-Digital Converter (ADC)

31.1	Introduction.....	667
31.1.1	Features.....	667
31.1.2	Block diagram.....	668
31.2	ADC Signal Descriptions.....	669
31.2.1	Analog power (VDDA).....	670
31.2.2	Analog ground (VSSA).....	670
31.2.3	Voltage reference select.....	670
31.2.4	Analog channel inputs (ADx).....	671
31.2.5	Differential analog channel inputs (DADx).....	671
31.3	Register Definition.....	671
31.3.1	ADC status and control registers 1 (ADCx_SC1n).....	674
31.3.2	ADC configuration register 1 (ADCx_CFG1).....	677
31.3.3	Configuration register 2 (ADCx_CFG2).....	679
31.3.4	ADC data result register (ADCx_Rn).....	680
31.3.5	Compare value registers (ADCx_CVn).....	681
31.3.6	Status and control register 2 (ADCx_SC2).....	682
31.3.7	Status and control register 3 (ADCx_SC3).....	684
31.3.8	ADC offset correction register (ADCx_OFS).....	685
31.3.9	ADC plus-side gain register (ADCx_PG).....	686
31.3.10	ADC minus-side gain register (ADCx_MG).....	686
31.3.11	ADC plus-side general calibration value register (ADCx_CLPD).....	687
31.3.12	ADC plus-side general calibration value register (ADCx_CLPS).....	688
31.3.13	ADC plus-side general calibration value register (ADCx_CLP4).....	688
31.3.14	ADC plus-side general calibration value register (ADCx_CLP3).....	689

Section Number	Title	Page
31.3.15	ADC plus-side general calibration value register (ADCx_CLP2).....	689
31.3.16	ADC plus-side general calibration value register (ADCx_CLP1).....	690
31.3.17	ADC plus-side general calibration value register (ADCx_CLP0).....	690
31.3.18	ADC PGA register (ADCx_PGA).....	691
31.3.19	ADC minus-side general calibration value register (ADCx_CLMD).....	692
31.3.20	ADC minus-side general calibration value register (ADCx_CLMS).....	693
31.3.21	ADC minus-side general calibration value register (ADCx_CLM4).....	693
31.3.22	ADC minus-side general calibration value register (ADCx_CLM3).....	694
31.3.23	ADC minus-side general calibration value register (ADCx_CLM2).....	694
31.3.24	ADC minus-side general calibration value register (ADCx_CLM1).....	695
31.3.25	ADC minus-side general calibration value register (ADCx_CLM0).....	695
31.4	Functional description.....	696
31.4.1	PGA functional description.....	696
31.4.2	Clock select and divide control.....	697
31.4.3	Voltage reference selection.....	697
31.4.4	Hardware trigger and channel selects.....	698
31.4.5	Conversion control.....	699
31.4.6	Automatic compare function.....	706
31.4.7	Calibration function.....	707
31.4.8	User defined offset function.....	709
31.4.9	Temperature sensor.....	710
31.4.10	MCU wait mode operation.....	710
31.4.11	MCU Normal Stop mode operation.....	711
31.4.12	MCU Low Power Stop mode operation.....	712

Section Number	Title	Page
31.5	Initialization information.....	712
31.5.1	ADC module initialization example.....	713
31.6	Application information.....	715
31.6.1	External pins and routing.....	715
31.6.2	Sources of error.....	717

Chapter 32 Comparator (CMP)

32.1	Introduction.....	723
32.2	CMP Features.....	723
32.3	6-bit DAC Key Features.....	724
32.4	ANMUX Key Features.....	725
32.5	CMP, DAC, and ANMUX Diagram.....	725
32.6	CMP Block Diagram.....	726
32.7	Memory Map/Register Definitions.....	728
32.7.1	CMP Control Register 0 (CMPx_CR0).....	729
32.7.2	CMP Control Register 1 (CMPx_CR1).....	730
32.7.3	CMP Filter Period Register (CMPx_FPR).....	731
32.7.4	CMP Status and Control Register (CMPx_SCR).....	732
32.7.5	DAC Control Register (CMPx_DACCR).....	733
32.7.6	MUX Control Register (CMPx_MUXCR).....	734
32.8	CMP Functional Description.....	735
32.8.1	CMP Functional Modes.....	736
32.8.2	Power Modes.....	745
32.8.3	Startup and Operation.....	746
32.8.4	Low Pass Filter.....	747
32.9	CMP Interrupts.....	749
32.10	CMP DMA Support.....	749
32.11	Digital to Analog Converter Block Diagram.....	749

Section Number	Title	Page
32.12	DAC Functional Description.....	750
32.12.1	Voltage Reference Source Select.....	750
32.13	DAC Resets.....	750
32.14	DAC Clocks.....	750
32.15	DAC Interrupts.....	751

Chapter 33 12-bit Digital-to-Analog Converter (DAC)

33.1	Introduction.....	753
33.2	Features.....	753
33.3	Block Diagram.....	753
33.4	Memory Map/Register Definition.....	754
33.4.1	DAC Data Low Register (DACx_DATnL).....	756
33.4.2	DAC Data High Register (DACx_DATnH).....	757
33.4.3	DAC Status Register (DACx_SR).....	757
33.4.4	DAC Control Register (DACx_C0).....	758
33.4.5	DAC Control Register 1 (DACx_C1).....	759
33.4.6	DAC Control Register 2 (DACx_C2).....	760
33.5	Functional Description.....	760
33.5.1	DAC Data Buffer Operation.....	761
33.5.2	DMA Operation.....	762
33.5.3	Resets.....	762
33.5.4	Low Power Mode Operation.....	762

Chapter 34 Voltage Reference (VREFV1)

34.1	Introduction.....	765
34.1.1	Overview.....	766
34.1.2	Features.....	766
34.1.3	Modes of Operation.....	767
34.1.4	VREF Signal Descriptions.....	767

Section Number	Title	Page
34.2	Memory Map and Register Definition.....	767
34.2.1	VREF Trim Register (VREF_TRM).....	768
34.2.2	VREF Status and Control Register (VREF_SC).....	769
34.3	Functional Description.....	770
34.3.1	Voltage Reference Disabled, SC[VREFEN] = 0.....	770
34.3.2	Voltage Reference Enabled, SC[VREFEN] = 1.....	770
34.4	Initialization/Application Information.....	771

Chapter 35 Programmable Delay Block (PDB)

35.1	Introduction.....	773
35.1.1	Features.....	773
35.1.2	Implementation.....	774
35.1.3	Back-to-back Acknowledgement Connections.....	775
35.1.4	DAC External Trigger Input Connections.....	775
35.1.5	Block Diagram.....	775
35.1.6	Modes of Operation.....	777
35.2	PDB Signal Descriptions.....	777
35.3	Memory Map and Register Definition.....	777
35.3.1	Status and Control Register (PDBx_SC).....	779
35.3.2	Modulus Register (PDBx_MOD).....	781
35.3.3	Counter Register (PDBx_CNT).....	782
35.3.4	Interrupt Delay Register (PDBx_IDLY).....	782
35.3.5	Channel n Control Register 1 (PDBx_CHnC1).....	783
35.3.6	Channel n Status Register (PDBx_CHnS).....	784
35.3.7	Channel n Delay 0 Register (PDBx_CHnDLY0).....	785
35.3.8	Channel n Delay 1 Register (PDBx_CHnDLY1).....	785
35.3.9	DAC Interval Trigger n Control Register (PDBx_DACINTCn).....	786
35.3.10	DAC Interval n Register (PDBx_DACINTn).....	786
35.3.11	Pulse-Out n Enable Register (PDBx_POEN).....	787

Section Number	Title	Page
35.3.12	Pulse-Out n Delay Register (PDBx_POnDLY).....	787
35.4	Functional Description.....	788
35.4.1	PDB Pre-trigger and Trigger Outputs.....	788
35.4.2	PDB Trigger Input Source Selection.....	790
35.4.3	DAC Interval Trigger Outputs.....	790
35.4.4	Pulse-Out's.....	791
35.4.5	Updating the Delay Registers.....	791
35.4.6	Interrupts.....	793
35.4.7	DMA.....	793
35.5	Application Information.....	793
35.5.1	Impact of Using the Prescaler and Multiplication Factor on Timing Resolution.....	793

Chapter 36 FlexTimer (FTM)

36.1	Introduction.....	795
36.1.1	FlexTimer Philosophy.....	795
36.1.2	Features.....	796
36.1.3	Modes of Operation.....	797
36.1.4	Block Diagram.....	797
36.2	FTM Signal Descriptions.....	800
36.2.1	EXTCLK — FTM External Clock.....	800
36.2.2	CHn — FTM Channel (n) I/O Pin.....	800
36.2.3	FAULTj — FTM Fault Input.....	800
36.2.4	PHA — FTM Quadrature Decoder Phase A Input.....	801
36.2.5	PHB — FTM Quadrature Decoder Phase B Input.....	801
36.3	Memory Map and Register Definition.....	801
36.3.1	Module Memory Map.....	801
36.3.2	Register Descriptions.....	801
36.3.3	Status and Control (FTMx_SC).....	808
36.3.4	Counter (FTMx_CNT).....	809

Section Number	Title	Page
36.3.5	Modulo (FTMx_MOD).....	810
36.3.6	Channel (n) Status and Control (FTMx_CnSC).....	811
36.3.7	Channel (n) Value (FTMx_CnV).....	814
36.3.8	Counter Initial Value (FTMx_CNTIN).....	815
36.3.9	Capture and Compare Status (FTMx_STATUS).....	815
36.3.10	Features Mode Selection (FTMx_MODE).....	818
36.3.11	Synchronization (FTMx_SYNC).....	819
36.3.12	Initial State for Channels Output (FTMx_OUTINIT).....	822
36.3.13	Output Mask (FTMx_OUTMASK).....	823
36.3.14	Function for Linked Channels (FTMx_COMBINE).....	825
36.3.15	Deadtime Insertion Control (FTMx_DEADTIME).....	830
36.3.16	FTM External Trigger (FTMx_EXTTRIG).....	831
36.3.17	Channels Polarity (FTMx_POL).....	833
36.3.18	Fault Mode Status (FTMx_FMS).....	835
36.3.19	Input Capture Filter Control (FTMx_FILTER).....	837
36.3.20	Fault Control (FTMx_FLTCTRL).....	839
36.3.21	Quadrature Decoder Control and Status (FTMx_QDCTRL).....	841
36.3.22	Configuration (FTMx_CONF).....	843
36.3.23	FTM Fault Input Polarity (FTMx_FLTPOL).....	844
36.3.24	Synchronization Configuration (FTMx_SYNCONF).....	846
36.3.25	FTM Inverting Control (FTMx_INVCTRL).....	848
36.3.26	FTM Software Output Control (FTMx_SWOCTRL).....	849
36.3.27	FTM PWM Load (FTMx_PWMLOAD).....	851
36.4	Functional Description.....	853
36.4.1	Clock Source.....	853
36.4.2	Prescaler.....	854
36.4.3	Counter.....	854
36.4.4	Input Capture Mode.....	859
36.4.5	Output Compare Mode.....	862

Section Number	Title	Page
36.4.6	Edge-Aligned PWM (EPWM) Mode.....	863
36.4.7	Center-Aligned PWM (CPWM) Mode.....	865
36.4.8	Combine Mode.....	866
36.4.9	Complementary Mode.....	874
36.4.10	Registers Updated from Write Buffers.....	875
36.4.11	PWM Synchronization.....	877
36.4.12	Inverting.....	893
36.4.13	Software Output Control.....	894
36.4.14	Deadtime Insertion.....	896
36.4.15	Output Mask.....	899
36.4.16	Fault Control.....	900
36.4.17	Polarity Control.....	903
36.4.18	Initialization.....	904
36.4.19	Features Priority.....	904
36.4.20	Channel Trigger Output.....	905
36.4.21	Initialization Trigger.....	906
36.4.22	Capture Test Mode.....	908
36.4.23	DMA.....	909
36.4.24	Dual Edge Capture Mode.....	910
36.4.25	Quadrature Decoder Mode.....	917
36.4.26	BDM Mode.....	922
36.4.27	Intermediate Load.....	923
36.4.28	Global Time Base (GTB).....	925
36.5	Reset Overview.....	926
36.6	FTM Interrupts.....	928
36.6.1	Timer Overflow Interrupt.....	928
36.6.2	Channel (n) Interrupt.....	928
36.6.3	Fault Interrupt.....	928

Chapter 37 Periodic Interrupt Timer (PIT)

37.1	Introduction.....	931
37.1.1	Block Diagram.....	931
37.1.2	Features.....	932
37.2	Signal Description.....	932
37.3	Memory Map/Register Description.....	933
37.3.1	PIT Module Control Register (PIT_MCR).....	934
37.3.2	Timer Load Value Register (PIT_LDVAL _n).....	935
37.3.3	Current Timer Value Register (PIT_CVAL _n).....	935
37.3.4	Timer Control Register (PIT_TCTRL _n).....	936
37.3.5	Timer Flag Register (PIT_TFLG _n).....	936
37.4	Functional Description.....	937
37.4.1	General.....	937
37.4.2	Interrupts.....	938
37.5	Initialization and Application Information.....	939

Chapter 38 Low power timer (LPTMR)

38.1	Introduction.....	941
38.1.1	Features.....	941
38.1.2	Modes of operation.....	941
38.2	LPTMR signal descriptions.....	942
38.2.1	Detailed signal descriptions.....	942
38.3	Memory map and register definition.....	943
38.3.1	Low Power Timer Control Status Register (LPTMR _x _CSR).....	944
38.3.2	Low Power Timer Prescale Register (LPTMR _x _PSR).....	945
38.3.3	Low Power Timer Compare Register (LPTMR _x _CMR).....	947
38.3.4	Low Power Timer Counter Register (LPTMR _x _CNR).....	947

Section Number	Title	Page
38.4	Functional description.....	948
38.4.1	LPTMR power and reset.....	948
38.4.2	LPTMR clocking.....	948
38.4.3	LPTMR prescaler/glitch filter.....	949
38.4.4	LPTMR compare.....	950
38.4.5	LPTMR counter.....	950
38.4.6	LPTMR hardware trigger.....	951
38.4.7	LPTMR interrupt.....	951

Chapter 39 Carrier Modulator Transmitter (CMT)

39.1	Introduction.....	953
39.2	Features.....	953
39.3	Block Diagram.....	954
39.4	Modes of Operation.....	955
39.4.1	Wait Mode Operation.....	956
39.4.2	Stop Mode Operation.....	956
39.5	CMT External Signal Descriptions.....	957
39.5.1	CMT_IRO — Infrared Output.....	957
39.6	Memory Map/Register Definition.....	957
39.6.1	CMT Carrier Generator High Data Register 1 (CMT_CGH1).....	958
39.6.2	CMT Carrier Generator Low Data Register 1 (CMT_CGL1).....	959
39.6.3	CMT Carrier Generator High Data Register 2 (CMT_CGH2).....	960
39.6.4	CMT Carrier Generator Low Data Register 2 (CMT_CGL2).....	960
39.6.5	CMT Output Control Register (CMT_OC).....	961
39.6.6	CMT Modulator Status and Control Register (CMT_MSC).....	962
39.6.7	CMT Modulator Data Register Mark High (CMT_CMD1).....	963
39.6.8	CMT Modulator Data Register Mark Low (CMT_CMD2).....	964
39.6.9	CMT Modulator Data Register Space High (CMT_CMD3).....	964
39.6.10	CMT Modulator Data Register Space Low (CMT_CMD4).....	965

Section Number	Title	Page
39.6.11	CMT Primary Prescaler Register (CMT_PPS).....	965
39.6.12	CMT Direct Memory Access (CMT_DMA).....	966
39.7	Functional Description.....	967
39.7.1	Clock Divider.....	967
39.7.2	Carrier Generator.....	967
39.7.3	Modulator.....	970
39.7.4	Extended Space Operation.....	974
39.8	CMT Interrupts and DMA.....	975

Chapter 40 Real Time Clock (RTC)

40.1	Introduction.....	977
40.1.1	Features.....	977
40.1.2	Modes of operation.....	977
40.1.3	RTC signal descriptions.....	978
40.2	Register definition.....	978
40.2.1	RTC Time Seconds Register (RTC_TSR).....	979
40.2.2	RTC Time Prescaler Register (RTC_TPR).....	980
40.2.3	RTC Time Alarm Register (RTC_TAR).....	980
40.2.4	RTC Time Compensation Register (RTC_TCR).....	981
40.2.5	RTC Control Register (RTC_CR).....	982
40.2.6	RTC Status Register (RTC_SR).....	984
40.2.7	RTC Lock Register (RTC_LR).....	985
40.2.8	RTC Interrupt Enable Register (RTC_IER).....	986
40.2.9	RTC Write Access Register (RTC_WAR).....	987
40.2.10	RTC Read Access Register (RTC_RAR).....	988
40.3	Functional description.....	989
40.3.1	Power, clocking and reset.....	989
40.3.2	Time counter.....	990
40.3.3	Compensation.....	991

Section Number	Title	Page
40.3.4	Time alarm.....	992
40.3.5	Update mode.....	992
40.3.6	Register lock.....	992
40.3.7	Access control.....	993
40.3.8	Interrupt.....	993

Chapter 41 Universal Serial Bus OTG Controller (USBOTG)

41.1	Introduction.....	995
41.1.1	USB.....	995
41.1.2	USB On-The-Go.....	996
41.1.3	USB-FS Features.....	997
41.2	Functional Description.....	997
41.2.1	Data Structures.....	997
41.3	Programmers Interface.....	998
41.3.1	Buffer Descriptor Table.....	998
41.3.2	Rx vs. Tx as a USB Target Device or USB Host.....	999
41.3.3	Addressing Buffer Descriptor Table Entries.....	1000
41.3.4	Buffer Descriptor Formats.....	1000
41.3.5	USB Transaction.....	1003
41.4	Memory Map/Register Definitions.....	1005
41.4.1	Peripheral ID Register (USB _x _PERID).....	1007
41.4.2	Peripheral ID Complement Register (USB _x _IDCOMP).....	1008
41.4.3	Peripheral Revision Register (USB _x _REV).....	1008
41.4.4	Peripheral Additional Info Register (USB _x _ADDINFO).....	1009
41.4.5	OTG Interrupt Status Register (USB _x _OTGISTAT).....	1009
41.4.6	OTG Interrupt Control Register (USB _x _OTGICR).....	1010
41.4.7	OTG Status Register (USB _x _OTGSTAT).....	1011
41.4.8	OTG Control Register (USB _x _OTGCTL).....	1012
41.4.9	Interrupt Status Register (USB _x _ISTAT).....	1013

Section Number	Title	Page
41.4.10	Interrupt Enable Register (USB _x _INTEN).....	1014
41.4.11	Error Interrupt Status Register (USB _x _ERRSTAT).....	1015
41.4.12	Error Interrupt Enable Register (USB _x _ERREN).....	1016
41.4.13	Status Register (USB _x _STAT).....	1018
41.4.14	Control Register (USB _x _CTL).....	1019
41.4.15	Address Register (USB _x _ADDR).....	1020
41.4.16	BDT Page Register 1 (USB _x _BDTPAGE1).....	1021
41.4.17	Frame Number Register Low (USB _x _FRMNUML).....	1021
41.4.18	Frame Number Register High (USB _x _FRMNUMH).....	1022
41.4.19	Token Register (USB _x _TOKEN).....	1022
41.4.20	SOF Threshold Register (USB _x _SOFTHLD).....	1023
41.4.21	BDT Page Register 2 (USB _x _BDTPAGE2).....	1024
41.4.22	BDT Page Register 3 (USB _x _BDTPAGE3).....	1024
41.4.23	Endpoint Control Register (USB _x _ENDPT _n).....	1024
41.4.24	USB Control Register (USB _x _USBCTRL).....	1026
41.4.25	USB OTG Observe Register (USB _x _OBSERVE).....	1026
41.4.26	USB OTG Control Register (USB _x _CONTROL).....	1027
41.4.27	USB Transceiver Control Register 0 (USB _x _USBTRC0).....	1028
41.5	OTG and Host Mode Operation.....	1029
41.6	Host Mode Operation Examples.....	1029
41.7	On-The-Go Operation.....	1032
41.7.1	OTG Dual Role A Device Operation.....	1033
41.7.2	OTG Dual Role B Device Operation.....	1034

Chapter 42

USB Device Charger Detection Module (USBDCD)

42.1	Preface.....	1037
42.1.1	References.....	1037
42.1.2	Acronyms and Abbreviations.....	1037
42.1.3	Glossary.....	1038

Section Number	Title	Page
42.2	Introduction.....	1038
42.2.1	Block Diagram.....	1038
42.2.2	Features.....	1039
42.2.3	Modes of Operation.....	1039
42.3	Module Signal Description.....	1040
42.3.1	USB Signal Descriptions.....	1040
42.4	Memory Map/Register Definition.....	1041
42.4.1	Control Register (USBDCD_CONTROL).....	1042
42.4.2	Clock Register (USBDCD_CLOCK).....	1043
42.4.3	Status Register (USBDCD_STATUS).....	1044
42.4.4	TIMER0 Register (USBDCD_TIMER0).....	1046
42.4.5	USBDCD_TIMER1.....	1047
42.4.6	USBDCD_TIMER2.....	1047
42.5	Functional Description.....	1048
42.5.1	The Charger Detection Sequence.....	1049
42.5.2	Interrupts and Events.....	1059
42.5.3	Resets.....	1060
42.6	Initialization Information.....	1061
42.7	Application Information.....	1061
42.7.1	External Pullups.....	1061
42.7.2	Dead or Weak Battery.....	1061
42.7.3	Handling Unplug Events.....	1062

Chapter 43 USB Voltage Regulator

43.1	Introduction.....	1063
43.1.1	Overview.....	1063
43.1.2	Features.....	1064
43.1.3	Modes of Operation.....	1065
43.2	USB Voltage Regulator Module Signal Descriptions.....	1065

Section Number	Title	Page
Chapter 44		
CAN (FlexCAN)		
44.1	Introduction.....	1067
44.1.1	Overview.....	1068
44.1.2	FlexCAN Module Features.....	1069
44.1.3	Modes of Operation.....	1070
44.2	FlexCAN Signal Descriptions.....	1072
44.2.1	CAN Rx	1072
44.2.2	CAN Tx	1072
44.3	Memory Map/Register Definition.....	1072
44.3.1	FlexCAN Memory Mapping.....	1072
44.3.2	Module Configuration Register (CANx_MCR).....	1078
44.3.3	Control 1 Register (CANx_CTRL1).....	1083
44.3.4	Free Running Timer (CANx_TIMER).....	1086
44.3.5	Rx Mailboxes Global Mask Register (CANx_RXMGMASK).....	1087
44.3.6	Rx 14 Mask Register (CANx_RX14MASK).....	1088
44.3.7	Rx 15 Mask Register (CANx_RX15MASK).....	1089
44.3.8	Error Counter (CANx_ECR).....	1090
44.3.9	Error and Status 1 Register (CANx_ESR1).....	1091
44.3.10	Interrupt Masks 2 Register (CANx_IMASK2).....	1095
44.3.11	Interrupt Masks 1 Register (CANx_IMASK1).....	1096
44.3.12	Interrupt Flags 2 Register (CANx_IFLAG2).....	1096
44.3.13	Interrupt Flags 1 Register (CANx_IFLAG1).....	1097
44.3.14	Control 2 Register (CANx_CTRL2).....	1100
44.3.15	Error and Status 2 Register (CANx_ESR2).....	1103
44.3.16	CRC Register (CANx_CRCR).....	1104
44.3.17	Rx FIFO Global Mask Register (CANx_RXFGMASK).....	1105
44.3.18	Rx FIFO Information Register (CANx_RXFIR).....	1106
44.3.19	Rx Individual Mask Registers (CANx_RXIMR _n).....	1107

Section Number	Title	Page
44.3.56	Message Buffer Structure.....	1108
44.3.57	Rx FIFO Structure.....	1114
44.4	Functional Description.....	1117
44.4.1	Transmit Process.....	1117
44.4.2	Arbitration process.....	1118
44.4.3	Receive Process.....	1122
44.4.4	Matching Process.....	1124
44.4.5	Move Process.....	1128
44.4.6	Data Coherence.....	1130
44.4.7	Rx FIFO.....	1134
44.4.8	CAN Protocol Related Features.....	1135
44.4.9	Modes of Operation Details.....	1142
44.4.10	Interrupts.....	1146
44.4.11	Bus Interface.....	1147
44.5	Initialization/Application Information.....	1148
44.5.1	FlexCAN Initialization Sequence.....	1148
 Chapter 45 SPI (DSPI) 		
45.1	Introduction.....	1151
45.1.1	Block Diagram.....	1151
45.1.2	Features.....	1152
45.1.3	DSPI Configurations.....	1153
45.1.4	Modes of Operation.....	1154
45.2	DSPI Signal Descriptions.....	1156
45.2.1	PCS0/SS — Peripheral Chip Select/Slave Select.....	1156
45.2.2	PCS1 - PCS3 — Peripheral Chip Selects 1 - 3.....	1156
45.2.3	PCS4 — Peripheral Chip Select 4.....	1157
45.2.4	PCS5/PCSS — Peripheral Chip Select 5/Peripheral Chip Select Strobe.....	1157
45.2.5	SIN — Serial Input.....	1157

Section Number	Title	Page
45.2.6	SOUT — Serial Output.....	1157
45.2.7	SCK — Serial Clock.....	1157
45.3	Memory Map/Register Definition.....	1158
45.3.1	DSPI Module Configuration Register (SPLx_MCR).....	1161
45.3.2	DSPI Transfer Count Register (SPLx_TCR).....	1164
45.3.3	DSPI Clock and Transfer Attributes Register (In Master Mode) (SPLx_CTAR _n).....	1164
45.3.4	DSPI Clock and Transfer Attributes Register (In Slave Mode) (SPLx_CTAR _n _SLAVE).....	1169
45.3.5	DSPI Status Register (SPLx_SR).....	1170
45.3.6	DSPI DMA/Interrupt Request Select and Enable Register (SPLx_RSER).....	1173
45.3.7	DSPI PUSH TX FIFO Register In Master Mode (SPLx_PUSHR).....	1175
45.3.8	DSPI PUSH TX FIFO Register In Slave Mode (SPLx_PUSHR_SLAVE).....	1177
45.3.9	DSPI POP RX FIFO Register (SPLx_POPR).....	1177
45.3.10	DSPI Transmit FIFO Registers (SPLx_TXFR _n).....	1178
45.3.11	DSPI Receive FIFO Registers (SPLx_RXFR _n).....	1178
45.4	Functional Description.....	1179
45.4.1	Start and Stop of DSPI Transfers.....	1180
45.4.2	Serial Peripheral Interface (SPI) Configuration.....	1180
45.4.3	DSPI Baud Rate and Clock Delay Generation.....	1184
45.4.4	Transfer Formats.....	1188
45.4.5	Continuous Serial Communications Clock.....	1193
45.4.6	Slave Mode Operation Constraints.....	1194
45.4.7	Interrupts/DMA Requests.....	1195
45.4.8	Power Saving Features.....	1197
45.5	Initialization/Application Information.....	1198
45.5.1	How to Manage DSPI Queues.....	1198
45.5.2	Switching Master and Slave Mode.....	1199
45.5.3	Baud Rate Settings.....	1200
45.5.4	Delay Settings.....	1200

Section Number	Title	Page
45.5.5	Calculation of FIFO Pointer Addresses.....	1201
Chapter 46		
Inter-Integrated Circuit (I2C)		
46.1	Introduction.....	1205
46.1.1	Features.....	1205
46.1.2	Modes of Operation.....	1206
46.1.3	Block Diagram.....	1206
46.2	I2C Signal Descriptions.....	1207
46.3	Memory Map and Register Descriptions.....	1207
46.3.1	I2C Address Register 1 (I2Cx_A1).....	1209
46.3.2	I2C Frequency Divider register (I2Cx_F).....	1209
46.3.3	I2C Control Register 1 (I2Cx_C1).....	1210
46.3.4	I2C Status Register (I2Cx_S).....	1212
46.3.5	I2C Data I/O register (I2Cx_D).....	1214
46.3.6	I2C Control Register 2 (I2Cx_C2).....	1215
46.3.7	I2C Programmable Input Glitch Filter register (I2Cx_FLT).....	1216
46.3.8	I2C Range Address register (I2Cx_RA).....	1216
46.3.9	I2C SMBus Control and Status register (I2Cx_SMB).....	1217
46.3.10	I2C Address Register 2 (I2Cx_A2).....	1218
46.3.11	I2C SCL Low Timeout Register High (I2Cx_SLTH).....	1219
46.3.12	I2C SCL Low Timeout Register Low (I2Cx_SLTL).....	1219
46.4	Functional Description.....	1220
46.4.1	I2C Protocol.....	1220
46.4.2	10-bit Address.....	1225
46.4.3	Address Matching.....	1226
46.4.4	System Management Bus Specification.....	1227
46.4.5	Resets.....	1230
46.4.6	Interrupts.....	1230
46.4.7	Programmable Input Glitch Filter.....	1232

Section Number	Title	Page
46.4.8	Address Matching Wakeup.....	1232
46.4.9	DMA Support.....	1233
46.5	Initialization/Application Information.....	1233

Chapter 47 Universal Asynchronous Receiver/Transmitter (UART)

47.1	Introduction.....	1237
47.1.1	Features.....	1237
47.1.2	Modes of operation.....	1239
47.2	UART signal descriptions.....	1240
47.2.1	Detailed signal descriptions.....	1240
47.3	Memory map and registers.....	1241
47.3.1	UART Baud Rate Registers:High (UARTx_BDH).....	1249
47.3.2	UART Baud Rate Registers: Low (UARTx_BDL).....	1251
47.3.3	UART Control Register 1 (UARTx_C1).....	1252
47.3.4	UART Control Register 2 (UARTx_C2).....	1253
47.3.5	UART Status Register 1 (UARTx_S1).....	1255
47.3.6	UART Status Register 2 (UARTx_S2).....	1258
47.3.7	UART Control Register 3 (UARTx_C3).....	1260
47.3.8	UART Data Register (UARTx_D).....	1262
47.3.9	UART Match Address Registers 1 (UARTx_MA1).....	1263
47.3.10	UART Match Address Registers 2 (UARTx_MA2).....	1264
47.3.11	UART Control Register 4 (UARTx_C4).....	1264
47.3.12	UART Control Register 5 (UARTx_C5).....	1265
47.3.13	UART Extended Data Register (UARTx_ED).....	1266
47.3.14	UART Modem Register (UARTx_MODEM).....	1267
47.3.15	UART Infrared Register (UARTx_IR).....	1269
47.3.16	UART FIFO Parameters (UARTx_PFIFO).....	1270
47.3.17	UART FIFO Control Register (UARTx_CFIFO).....	1271
47.3.18	UART FIFO Status Register (UARTx_SFIFO).....	1272

Section Number	Title	Page
47.3.19	UART FIFO Transmit Watermark (UARTx_TWFIFO).....	1274
47.3.20	UART FIFO Transmit Count (UARTx_TCFIFO).....	1274
47.3.21	UART FIFO Receive Watermark (UARTx_RWFIFO).....	1275
47.3.22	UART FIFO Receive Count (UARTx_RCFIFO).....	1276
47.3.23	UART 7816 Control Register (UARTx_C7816).....	1276
47.3.24	UART 7816 Interrupt Enable Register (UARTx_IE7816).....	1278
47.3.25	UART 7816 Interrupt Status Register (UARTx_IS7816).....	1279
47.3.26	UART 7816 Wait Parameter Register (UARTx_WP7816T0).....	1281
47.3.27	UART 7816 Wait Parameter Register (UARTx_WP7816T1).....	1282
47.3.28	UART 7816 Wait N Register (UARTx_WN7816).....	1283
47.3.29	UART 7816 Wait FD Register (UARTx_WF7816).....	1283
47.3.30	UART 7816 Error Threshold Register (UARTx_ET7816).....	1284
47.3.31	UART 7816 Transmit Length Register (UARTx_TL7816).....	1285
47.4	Functional description.....	1285
47.4.1	Transmitter.....	1285
47.4.2	Receiver.....	1291
47.4.3	Baud rate generation.....	1305
47.4.4	Data format (non ISO-7816).....	1307
47.4.5	Single-wire operation.....	1310
47.4.6	Loop operation.....	1311
47.4.7	ISO-7816 / smartcard support.....	1311
47.4.8	Infrared interface.....	1316
47.5	Reset.....	1317
47.6	System level interrupt sources.....	1317
47.6.1	RXEDGIF description.....	1318
47.7	DMA operation.....	1319
47.8	Application information.....	1319
47.8.1	Transmit/receive data buffer operation.....	1319

Section Number	Title	Page
47.8.2	ISO-7816 initialization sequence.....	1320
47.8.3	Initialization sequence (non ISO-7816).....	1322
47.8.4	Overrun (OR) flag implications.....	1323
47.8.5	Overrun NACK considerations.....	1324
47.8.6	Match address registers.....	1325
47.8.7	Modem feature.....	1325
47.8.8	IrDA minimum pulse width.....	1326
47.8.9	Clearing 7816 wait timer (WT, BWT, CWT) interrupts.....	1326
47.8.10	Legacy and reverse compatibility considerations.....	1327

Chapter 48

Secured digital host controller (SDHC)

48.1	Introduction.....	1329
48.2	Overview.....	1329
48.2.1	Supported types of cards.....	1329
48.2.2	SDHC block diagram.....	1330
48.2.3	Features.....	1331
48.2.4	Modes and operations.....	1332
48.3	SDHC signal descriptions.....	1333
48.4	Memory map and register definition.....	1334
48.4.1	DMA System Address Register (SDHC_DSADDR).....	1335
48.4.2	Block Attributes Register (SDHC_BLKATTR).....	1336
48.4.3	Command Argument Register (SDHC_CMDARG).....	1337
48.4.4	Transfer Type Register (SDHC_XFERTYP).....	1338
48.4.5	Command Response 0 (SDHC_CMDRSP0).....	1342
48.4.6	Command Response 1 (SDHC_CMDRSP1).....	1343
48.4.7	Command Response 2 (SDHC_CMDRSP2).....	1343
48.4.8	Command Response 3 (SDHC_CMDRSP3).....	1343
48.4.9	Buffer Data Port Register (SDHC_DATPORT).....	1345
48.4.10	Present State Register (SDHC_PRSTAT).....	1345

Section Number	Title	Page
48.4.11	Protocol Control Register (SDHC_PROCTL).....	1350
48.4.12	System Control Register (SDHC_SYSCTL).....	1354
48.4.13	Interrupt Status Register (SDHC_IRQSTAT).....	1357
48.4.14	Interrupt Status Enable Register (SDHC_IRQSTATEN).....	1363
48.4.15	Interrupt Signal Enable Register (SDHC_IRQSIGEN).....	1366
48.4.16	Auto CMD12 Error Status Register (SDHC_AC12ERR).....	1368
48.4.17	Host Controller Capabilities (SDHC_HTCAPBLT).....	1371
48.4.18	Watermark Level Register (SDHC_WML).....	1373
48.4.19	Force Event Register (SDHC_FEVT).....	1373
48.4.20	ADMA Error Status Register (SDHC_ADMAES).....	1376
48.4.21	ADMA System Address Register (SDHC_ADSADDR).....	1378
48.4.22	Vendor Specific Register (SDHC_VENDOR).....	1378
48.4.23	MMC Boot Register (SDHC_MMBOOT).....	1380
48.4.24	Host Controller Version (SDHC_HOSTVER).....	1381
48.5	Functional description.....	1382
48.5.1	Data buffer.....	1382
48.5.2	DMA crossbar switch interface.....	1388
48.5.3	SD protocol unit.....	1394
48.5.4	Clock & reset manager.....	1396
48.5.5	Clock generator.....	1397
48.5.6	SDIO card interrupt.....	1397
48.5.7	Card insertion and removal detection.....	1399
48.5.8	Power management and wakeup events.....	1400
48.5.9	MMC fast boot.....	1401
48.6	Initialization/application of SDHC.....	1403
48.6.1	Command send and response receive basic operation.....	1403

Section Number	Title	Page
48.6.2	Card identification mode.....	1404
48.6.3	Card access.....	1409
48.6.4	Switch function.....	1420
48.6.5	ADMA operation.....	1422
48.6.6	Fast boot operation.....	1423
48.6.7	Commands for MMC/SD/SDIO/CE-ATA.....	1427
48.7	Software restrictions.....	1433
48.7.1	Initialization active.....	1433
48.7.2	Software polling procedure.....	1434
48.7.3	Suspend operation.....	1434
48.7.4	Data length setting.....	1434
48.7.5	(A)DMA address setting.....	1434
48.7.6	Data port access.....	1435
48.7.7	Change clock frequency.....	1435
48.7.8	Multi-block read.....	1435

Chapter 49 Integrated interchip sound (I2S)

49.1	Introduction.....	1437
49.1.1	Block diagram.....	1437
49.1.2	Features.....	1438
49.1.3	Modes of operation.....	1439
49.2	I2S signal descriptions.....	1441
49.3	Memory map/register definition.....	1445
49.3.1	I ² S Transmit Data Registers 0 (I2Sx_TX0).....	1447
49.3.2	I ² S Transmit Data Registers 1 (I2Sx_TX1).....	1447
49.3.3	I ² S Receive Data Registers 0 (I2Sx_RX0).....	1448
49.3.4	I ² S Receive Data Registers 1 (I2Sx_RX1).....	1448
49.3.5	I ² S Control Register (I2Sx_CR).....	1449
49.3.6	I ² S Interrupt Status Register (I2Sx_ISR).....	1452

Section Number	Title	Page
49.3.7	I ² S Interrupt Enable Register (I2Sx_IER).....	1457
49.3.8	I ² S Transmit Configuration Register (I2Sx_TCR).....	1461
49.3.9	I ² S Receive Configuration Register (I2Sx_RCR).....	1463
49.3.10	I ² S Transmit Clock Control Registers (I2Sx_TCCR).....	1465
49.3.11	I ² S Receive Clock Control Registers (I2Sx_RCCR).....	1467
49.3.12	I ² S FIFO Control/Status Register (I2Sx_FCSR).....	1468
49.3.13	I ² S AC97 Control Register (I2Sx_ACNT).....	1474
49.3.14	I ² S AC97 Command Address Register (I2Sx_ACADD).....	1475
49.3.15	I ² S AC97 Command Data Register (I2Sx_ACDAT).....	1476
49.3.16	I ² S AC97 Tag Register (I2Sx_ATAG).....	1476
49.3.17	I ² S Transmit Time Slot Mask Register (I2Sx_TMSK).....	1477
49.3.18	I ² S Receive Time Slot Mask Register (I2Sx_RMSK).....	1477
49.3.19	I ² S AC97 Channel Status Register (I2Sx_ACCST).....	1478
49.3.20	I ² S AC97 Channel Enable Register (I2Sx_ACCEN).....	1478
49.3.21	I ² S AC97 Channel Disable Register (I2Sx_ACCDIS).....	1479
49.4	Functional description.....	1479
49.4.1	Detailed operating mode descriptions.....	1479
49.4.2	I2S clocking.....	1495
49.4.3	External frame and clock operation.....	1500
49.4.4	Receive interrupt enable bit description.....	1502
49.4.5	Transmit interrupt enable bit description.....	1503
49.4.6	Internal frame and clock shutdown.....	1504
49.4.7	Reset.....	1505
49.5	Initialization/application information.....	1505
 Chapter 50 General purpose input/output (GPIO) 		
50.1	Introduction.....	1509
50.1.1	Features.....	1509

Section Number	Title	Page
50.1.2	Modes of operation.....	1509
50.1.3	GPIO signal descriptions.....	1510
50.2	Memory map and register definition.....	1511
50.2.1	Port Data Output Register (GPIOx_PDOR).....	1514
50.2.2	Port Set Output Register (GPIOx_PSOR).....	1514
50.2.3	Port Clear Output Register (GPIOx_PCOR).....	1515
50.2.4	Port Toggle Output Register (GPIOx_PTOR).....	1515
50.2.5	Port Data Input Register (GPIOx_PDIR).....	1516
50.2.6	Port Data Direction Register (GPIOx_PDDR).....	1516
50.3	Functional description.....	1517
50.3.1	General purpose input.....	1517
50.3.2	General purpose output.....	1517

Chapter 51 Touch sense input (TSI)

51.1	Introduction.....	1519
51.2	Features.....	1519
51.3	Overview.....	1520
51.3.1	Electrode capacitance measurement unit.....	1520
51.3.2	Electrode scan unit.....	1521
51.3.3	Touch detection unit.....	1522
51.4	Modes of operation.....	1522
51.4.1	TSI disabled mode.....	1522
51.4.2	TSI active mode.....	1522
51.4.3	TSI low power mode.....	1523
51.4.4	Block diagram.....	1523
51.5	TSI signal descriptions.....	1524
51.5.1	TSI_IN[15:0].....	1524
51.6	Memory map and register definition.....	1524
51.6.1	General Control and Status Register (TSIx_GENCS).....	1526

Section Number	Title	Page
51.6.2	SCAN control register (TSIx_SCANC).....	1529
51.6.3	Pin enable register (TSIx_PEN).....	1532
51.6.4	Status Register (TSIx_STATUS).....	1535
51.6.5	Counter Register (TSIx_CNTR n).....	1538
51.6.6	Channel n threshold register (TSIx_THRESHL Dn).....	1539
51.7	Functional descriptions.....	1539
51.7.1	Capacitance measurement.....	1539
51.7.2	TSI measurement result.....	1542
51.7.3	Electrode scan unit.....	1543
51.7.4	Touch detection unit.....	1546
51.8	Application information.....	1547
51.8.1	TSI module sensitivity.....	1547

Chapter 52 LCD Controller (SLCD)

52.1	Introduction	1549
52.1.1	Features.....	1549
52.1.2	Modes of operation.....	1550
52.1.3	Block diagram.....	1551
52.2	LCD Signal Descriptions.....	1552
52.2.1	LCD_P[63:0].....	1553
52.2.2	VLL1, VLL2, VLL3.....	1553
52.2.3	Vcap1, Vcap2.....	1553
52.3	Memory map and register definition.....	1553
52.3.1	LCD general control register (LCD_GCR).....	1555
52.3.2	LCD auxiliary register (LCD_AR).....	1559
52.3.3	LCD fault detect control register (LCD_FDCR).....	1561
52.3.4	LCD fault detect status register (LCD_FDSR).....	1562
52.3.5	LCD pin enable register (LCD_PEN n).....	1563
52.3.6	LCD backplane enable register (LCD_BPEN n).....	1564

Section Number	Title	Page
52.3.7	LCD waveform register (LCD_WF3TO0).....	1565
52.3.8	LCD waveform register (LCD_WF7TO4).....	1566
52.3.9	LCD waveform register (LCD_WF11TO8).....	1566
52.3.10	LCD waveform register (LCD_WF15TO12).....	1567
52.3.11	LCD waveform register (LCD_WF19TO16).....	1568
52.3.12	LCD waveform register (LCD_WF23TO20).....	1568
52.3.13	LCD waveform register (LCD_WF27TO24).....	1569
52.3.14	LCD waveform register (LCD_WF31TO28).....	1570
52.3.15	LCD waveform register (LCD_WF35TO32).....	1570
52.3.16	LCD waveform register (LCD_WF39TO36).....	1571
52.3.17	LCD waveform register (LCD_WF43TO40).....	1572
52.3.18	LCD waveform register (LCD_WF47TO44).....	1572
52.3.19	LCD waveform register (LCD_WF51TO48).....	1573
52.3.20	LCD waveform register (LCD_WF55TO52).....	1573
52.3.21	LCD waveform register (LCD_WF59TO56).....	1574
52.3.22	LCD waveform register (LCD_WF63TO60).....	1575
52.4	Functional description.....	1575
52.4.1	LCD controller driver description.....	1576
52.4.2	WFyTOx registers.....	1585
52.4.3	LCD display modes.....	1586
52.4.4	LCD charge pump and power supply operation.....	1588
52.4.5	Resets.....	1593
52.4.6	Interrupts.....	1593
52.4.7	LCD display fault detect circuit.....	1594
52.5	Initialization section.....	1601
52.5.1	Initialization sequence.....	1601

Section Number	Title	Page
52.5.2	Initialization Examples.....	1602
52.6	Application information.....	1608
52.6.1	LCD seven segment example description.....	1609
52.6.2	LCD contrast control.....	1612
Chapter 53		
JTAG Controller (JTAGC)		
53.1	Introduction.....	1615
53.1.1	Block diagram.....	1615
53.1.2	Features.....	1616
53.1.3	Modes of operation.....	1616
53.2	External signal description.....	1618
53.2.1	TCK—Test clock input.....	1618
53.2.2	TDI—Test data input.....	1618
53.2.3	TDO—Test data output.....	1618
53.2.4	TMS—Test mode select.....	1618
53.3	Register description.....	1619
53.3.1	Instruction register.....	1619
53.3.2	Bypass register.....	1619
53.3.3	Device identification register.....	1619
53.3.4	Boundary scan register.....	1620
53.4	Functional description.....	1621
53.4.1	JTAGC reset configuration.....	1621
53.4.2	IEEE 1149.1-2001 (JTAG) Test Access Port.....	1621
53.4.3	TAP controller state machine.....	1621
53.4.4	JTAGC block instructions.....	1623
53.4.5	Boundary scan.....	1626
53.5	Initialization/Application information.....	1626

Chapter 1

About This Document

1.1 Overview

1.1.1 Purpose

This document describes the features, architecture, and programming model of the Freescale K40 microcontroller.

1.1.2 Audience

This document is primarily for system architects and software application developers who are using or considering using the K40 microcontroller in a system.

1.2 Conventions

1.2.1 Numbering systems

The following suffixes identify different numbering systems:

This suffix	Identifies a
b	Binary number. For example, the binary equivalent of the number 5 is written 101b. In some cases, binary numbers are shown with the prefix <i>0b</i> .
d	Decimal number. Decimal numbers are followed by this suffix only when the possibility of confusion exists. In general, decimal numbers are shown without a suffix.
h	Hexadecimal number. For example, the hexadecimal equivalent of the number 60 is written 3Ch. In some cases, hexadecimal numbers are shown with the prefix <i>0x</i> .

1.2.2 Typographic notation

The following typographic notation is used throughout this document:

Example	Description
<i>placeholder, x</i>	Items in italics are placeholders for information that you provide. Italicized text is also used for the titles of publications and for emphasis. Plain lowercase letters are also used as placeholders for single letters and numbers.
code	Fixed-width type indicates text that must be typed exactly as shown. It is used for instruction mnemonics, directives, symbols, subcommands, parameters, and operators. Fixed-width type is also used for example code. Instruction mnemonics and directives in text and tables are shown in all caps; for example, BSR.
SR[SCM]	A mnemonic in brackets represents a named field in a register. This example refers to the Scaling Mode (SCM) field in the Status Register (SR).
REVNO[6:4], XAD[7:0]	Numbers in brackets and separated by a colon represent either: <ul style="list-style-type: none"> • A subset of a register's named field For example, REVNO[6:4] refers to bits 6–4 that are part of the COREREV field that occupies bits 6–0 of the REVNO register. • A continuous range of individual signals of a bus For example, XAD[7:0] refers to signals 7–0 of the XAD bus.

1.2.3 Special terms

The following terms have special meanings:

Term	Meaning
asserted	Refers to the state of a signal as follows: <ul style="list-style-type: none"> • An active-high signal is asserted when high (1). • An active-low signal is asserted when low (0).
deasserted	Refers to the state of a signal as follows: <ul style="list-style-type: none"> • An active-high signal is deasserted when low (0). • An active-low signal is deasserted when high (1). <p>In some cases, deasserted signals are described as <i>negated</i>.</p>
reserved	Refers to a memory space, register, or field that is either reserved for future use or for which, when written to, the module or chip behavior is unpredictable.

Chapter 2

Introduction

2.1 Overview

This chapter provides an overview of the Kinetis portfolio and K40 family of products. It also presents high-level descriptions of the modules available on the devices covered by this document.

2.2 K40 Family Introduction

The K40 MCU family is pin, peripheral and software compatible with the K10 MCU family and adds full-speed USB 2.0 On-The-Go with device charger detect capability and a flexible, low-power segment LCD controller with support for up to 320 segments. Devices start from 64 KB of flash in 64QFN packages extending up to 512 KB in a 144MAPBGA package with a rich suite of analog, communication, timing and control peripherals.

2.3 Module Functional Categories

The modules on this device are grouped into functional categories. The following sections describe the modules assigned to each category in more detail.

Table 2-1. Module functional categories

Module category	Description
ARM Cortex-M4 core	<ul style="list-style-type: none"> 32-bit MCU core from ARM's Cortex-M class adding DSP instructions, 1.25 DMIPS/MHz, based on ARMv7 architecture

Table continues on the next page...

Table 2-1. Module functional categories (continued)

Module category	Description
System	<ul style="list-style-type: none"> • System integration module • Power management and mode controllers <ul style="list-style-type: none"> • Multiple power modes available based on run, wait, stop, and power-down modes • Low-leakage wakeup unit • Miscellaneous control module • Crossbar switch • Memory protection unit • Peripheral bridge • Direct memory access (DMA) controller with multiplexer to increase available DMA requests • External watchdog monitor • Watchdog
Memories	<ul style="list-style-type: none"> • Internal memories include: <ul style="list-style-type: none"> • Program flash memory • Programming acceleration RAM • SRAM • Serial programming interface: EzPort
Clocks	<ul style="list-style-type: none"> • Multiple clock generation options available from internally- and externally-generated clocks • System oscillator to provide clock source for the MCU • RTC oscillator to provide clock source for the RTC
Security	<ul style="list-style-type: none"> • Cyclic Redundancy Check module for error detection • Tamper detect and secure storage
Analog	<ul style="list-style-type: none"> • High speed analog-to-digital converter with integrated programmable gain amplifier • Comparator • Digital-to-analog converter • Internal voltage reference
Timers	<ul style="list-style-type: none"> • Programmable delay block • FlexTimers • Periodic interrupt timer • Low power timer • Carrier modulator transmitter • Independent real time clock
Communications	<ul style="list-style-type: none"> • USB OTG controller with built-in FS/LS transceiver • USB device charger detect • USB voltage regulator • CAN • Serial peripheral interface • Inter-integrated circuit (I²C) • UART • Secured Digital host controller • Integrated interchip sound (I²S)
Human-Machine Interfaces (HMI)	<ul style="list-style-type: none"> • General purpose input/output controller • Capacitive touch sense input interface enabled in hardware • Segment LCD controller

2.3.1 ARM Cortex-M4 Core Modules

The following core modules are available on this device.

Table 2-2. Core modules

Module	Description
ARM Cortex-M4	The ARM Cortex-M4 is the newest member of the Cortex M Series of processors targeting microcontroller cores focused on very cost sensitive, deterministic, interrupt driven environments. The Cortex M4 processor is based on the ARMv7 Architecture and Thumb®-2 ISA and is upward compatible with the Cortex M3, Cortex M1, and Cortex M0 architectures. Cortex M4 improvements include an ARMv7 Thumb-2 DSP (ported from the ARMv7-A/R profile architectures) providing 32-bit instructions with SIMD (single instruction multiple data) DSP style multiply-accumulates and saturating arithmetic.
NVIC	The ARMv7-M exception model and nested-vector interrupt controller (NVIC) implement a relocatable vector table supporting many external interrupts, a single non-maskable interrupt (NMI), and priority levels. The NVIC replaces shadow registers with equivalent system and simplified programmability. The NVIC contains the address of the function to execute for a particular handler. The address is fetched via the instruction port allowing parallel register stacking and look-up. The first sixteen entries are allocated to ARM internal sources with the others mapping to MCU-defined interrupts.
AWIC	The primary function of the Asynchronous Wake-up Interrupt Controller (AWIC) is to detect asynchronous wake-up events in stop modes and signal to clock control logic to resume system clocking. After clock restart, the NVIC observes the pending interrupt and performs the normal interrupt or event processing.
Debug interfaces	Most of this device's debug is based on the ARM CoreSight™ architecture. Four debug interfaces are supported: <ul style="list-style-type: none"> • IEEE 1149.1 JTAG • IEEE 1149.7 JTAG (cJTAG) • Serial Wire Debug (SWD) • ARM Real-Time Trace Interface

2.3.2 System Modules

The following system modules are available on this device.

Table 2-3. System modules

Module	Description
System integration module (SIM)	The SIM includes integration logic and several module configuration settings.
Mode controller	The MC provides control and protection on entry and exit to each power mode, control for the Power management controller (PMC), and reset entry and exit for the complete MCU.
Power management controller (PMC)	The PMC provides the user with multiple power options. Ten different modes are supported that allow the user to optimize power consumption for the level of functionality needed. Includes power-on-reset (POR) and integrated low voltage detect (LVD) with reset (brownout) capability and selectable LVD trip points.

Table continues on the next page...

Table 2-3. System modules (continued)

Module	Description
Low-leakage wakeup unit (LLWU)	The LLWU module allows the device to wake from low leakage power modes (LLS and VLLS) through various internal peripheral and external pin sources.
Miscellaneous control module (MCM)	The MCM includes integration logic and embedded trace buffer details.
Crossbar switch (XBS)	The XBS connects bus masters and bus slaves, allowing all bus masters to access different bus slaves simultaneously and providing arbitration among the bus masters when they access the same slave.
Memory protection unit (MPU)	The MPU provides memory protection and task isolation. It concurrently monitors all bus master transactions for the slave connections.
Peripheral bridges	The peripheral bridge converts the crossbar switch interface to an interface to access a majority of peripherals on the device.
DMA multiplexer (DMAMUX)	The DMA multiplexer selects from many DMA requests down to 16 for the DMA controller.
Direct memory access (DMA) controller	The DMA controller provides programmable channels with transfer control descriptors for data movement via dual-address transfers for 8-, 16-, 32- and 128-bit data values.
External watchdog monitor (EWM)	The EWM is a redundant mechanism to the software watchdog module that monitors both internal and external system operation for fail conditions.
Software watchdog (WDOG)	The WDOG monitors internal system operation and forces a reset in case of failure. It can run from an independent 1 KHz low power oscillator with a programmable refresh window to detect deviations in program flow or system frequency.

2.3.3 Memories and Memory Interfaces

The following memories and memory interfaces are available on this device.

Table 2-4. Memories and memory interfaces

Module	Description
Flash memory	<ul style="list-style-type: none"> • Program flash memory — non-volatile flash memory that can execute program code • FlexMemory — encompasses the following memory types: <ul style="list-style-type: none"> • Programming acceleration RAM — RAM memory that accelerates flash programming
Flash memory controller	Manages the interface between the device and the on-chip flash memory.
SRAM	Internal system RAM. Partial SRAM kept powered in VLLS2 low leakage mode.
SRAM controller	Manages simultaneous accesses to system RAM by multiple master peripherals and core.
System register file	32-byte register file that is accessible during all power modes and is powered by VDD.
VBAT register file	32-byte register file that is accessible during all power modes and is powered by VBAT.

Table continues on the next page...

Table 2-4. Memories and memory interfaces (continued)

Module	Description
Serial programming interface (EzPort)	Same serial interface as, and subset of, the command set used by industry-standard SPI flash memories. Provides the ability to read, erase, and program flash memory and reset command to boot the system after flash programming.

2.3.4 Clocks

The following clock modules are available on this device.

Table 2-5. Clock modules

Module	Description
Multi-clock generator (MCG)	The MCG provides several clock sources for the MCU that include: <ul style="list-style-type: none"> • Phase-locked loop (PLL) — Voltage-controlled oscillator (VCO) • Frequency-locked loop (FLL) — Digitally-controlled oscillator (DCO) • Internal reference clocks — Can be used as a clock source for other on-chip peripherals
System oscillator	The system oscillator, in conjunction with an external crystal or resonator, generates a reference clock for the MCU.
Real-time clock oscillator	The RTC oscillator has an independent power supply and supports a 32 kHz crystal oscillator to feed the RTC clock. Optionally, the RTC oscillator can replace the system oscillator as the main oscillator source.

2.3.5 Security and Integrity modules

The following security and integrity modules are available on this device:

Table 2-6. Security and integrity modules

Module	Description
Cyclic Redundancy Check (CRC)	Hardware CRC generator circuit using 16/32-bit shift register. Error detection for all single, double, odd, and most multi-bit errors, programmable initial seed value, and optional feature to transpose input data and CRC result via transpose register.
Tamper Detection Module (TDM)	The Tamper Detect and Secure Storage includes a 32-byte secure memory that is asynchronously erased on any tamper detect. In addition, it can optionally force a System Reset and/or invalidate the Real Time Clock.

2.3.6 Analog modules

The following analog modules are available on this device:

Table 2-7. Analog modules

Module	Description
16-bit analog-to-digital converters (ADC) and programmable-gain amplifiers (PGA)	16-bit successive-approximation ADC designed with integrated programmable gain amplifiers (PGA)
Analog comparators	Compares two analog input voltages across the full range of the supply voltage.
6-bit digital-to-analog converters (DAC)	64-tap resistor ladder network which provides a selectable voltage reference for applications where voltage reference is needed.
12-bit digital-to-analog converters (DAC)	Low-power general-purpose DAC, whose output can be placed on an external pin or set as one of the inputs to the analog comparator or ADC.
Voltage reference (VREF)	Supplies an accurate voltage output that is trimmable in 0.5 mV steps. The VREF can be used in medical applications, such as glucose meters, to provide a reference voltage to biosensors or as a reference to analog peripherals, such as the ADC, DAC, or CMP.

2.3.7 Timer modules

The following timer modules are available on this device:

Table 2-8. Timer modules

Module	Description
Programmable delay block (PDB)	<ul style="list-style-type: none"> • 16-bit resolution • 3-bit prescaler • Positive transition of trigger event signal initiates the counter • Supports two triggered delay output signals, each with an independently-controlled delay from the trigger event • Outputs can be OR'd together to schedule two conversions from one input trigger event and can schedule precise edge placement for a pulsed output. This feature is used to generate the control signal for the CMP windowing feature and output to a package pin if needed for applications, such as critical conductive mode power factor correction. • Continuous-pulse output or single-shot mode supported, each output is independently enabled, with possible trigger events • Supports bypass mode • Supports DMA

Table continues on the next page...

Table 2-8. Timer modules (continued)

Module	Description
Flexible timer modules (FTM)	<ul style="list-style-type: none"> • Selectable FTM source clock, programmable prescaler • 16-bit counter supporting free-running or initial/final value, and counting is up or up-down • Input capture, output compare, and edge-aligned and center-aligned PWM modes • Operation of FTM channels as pairs with equal outputs, pairs with complimentary outputs, or independent channels with independent outputs • Deadtime insertion is available for each complementary pair • Generation of hardware triggers • Software control of PWM outputs • Up to 4 fault inputs for global fault control • Configurable channel polarity • Programmable interrupt on input capture, reference compare, overflowed counter, or detected fault condition • Quadrature decoder with input filters, relative position counting, and interrupt on position count or capture of position count on external event • DMA support for FTM events
Periodic interrupt timers (PIT)	<ul style="list-style-type: none"> • Four general purpose interrupt timers • Interrupt timers for triggering ADC conversions • 32-bit counter resolution • Clocked by system clock frequency • DMA support
Low-power timer (LPTimer)	<ul style="list-style-type: none"> • Selectable clock for prescaler/glitch filter of 1 kHz (internal LPO), 32.768 kHz (external crystal), or internal reference clock • Configurable Glitch Filter or Prescaler with 16-bit counter • 16-bit time or pulse counter with compare • Interrupt generated on Timer Compare • Hardware trigger generated on Timer Compare
Carrier modulator timer (CMT)	<ul style="list-style-type: none"> • Four CMT modes of operation: <ul style="list-style-type: none"> • Time with independent control of high and low times • Baseband • Frequency shift key (FSK) • Direct software control of CMT_IRO pin • Extended space operation in time, baseband, and FSK modes • Selectable input clock divider • Interrupt on end of cycle with the ability to disable CMT_IRO pin and use as timer interrupt • DMA support
Real-time clock (RTC)	<ul style="list-style-type: none"> • Independent power supply, POR, and 32 kHz Crystal Oscillator • 32-bit seconds counter with 32-bit Alarm • 16-bit Prescaler with compensation that can correct errors between 0.12 ppm and 3906 ppm

2.3.8 Communication interfaces

The following communication interfaces are available on this device:

Table 2-9. Communication modules

Module	Description
USB OTG (low-/full-speed)	USB 2.0 compliant module with support for host, device, and On-The-Go modes. Includes an on-chip transceiver for full and low speeds.
USB Device Charger Detect (USBDCD)	The USBDCD monitors the USB data lines to detect a smart charger meeting the USB Battery Charging Specification Rev1.1. This information allows the MCU to better manage the battery charging IC in a portable device.
USB voltage regulator	Up to 5 V regulator input typically provided by USB VBUS power with 3.3 V regulated output that powers on-chip USB subsystem, capable of sourcing 120 mA to external board components.
Controller Area Network (CAN)	Supports the full implementation of the CAN Specification Version 2.0, Part B
Serial peripheral interface (SPI)	Synchronous serial bus for communication to an external device
Inter-integrated circuit (I2C)	Allows communication between a number of devices. Also supports the System Management Bus (SMBus) Specification, version 2.
Universal asynchronous receiver/transmitters (UART)	Asynchronous serial bus communication interface with programmable 8- or 9-bit data format and support of ISO 7816 smart card interface
Secure Digital host controller (SDHC)	Interface between the host system and the SD, SDIO, MMC, or CE-ATA cards. The SDHC acts as a bridge, passing host bus transactions to the cards by sending commands and performing data accesses to/from the cards. It handles the SD, SDIO, MMC, and CE-ATA protocols at the transmission level.
I2S	The I ² S is a full-duplex, serial port that allows the chip to communicate with a variety of serial devices, such as standard codecs, digital signal processors (DSPs), microprocessors, peripherals, and audio codecs that implement the inter-IC sound bus (I ² S) and the Intel [®] AC97 standards

2.3.9 Human-machine interfaces

The following human-machine interfaces (HMI) are available on this device:

Table 2-10. HMI modules

Module	Description
General purpose input/output (GPIO)	All general purpose input or output (GPIO) pins are capable of interrupt and DMA request generation. All GPIO pins have 5 V tolerance.
Capacitive touch sense input (TSI)	Contains up to 16 channel inputs for capacitive touch sensing applications. Operation is available in low-power modes via interrupts.
Segment LCD controller	Generates the appropriate waveforms to drive multiplexed numeric, alpha-numeric, or custom LCD panels. Supports 3V or 5V LCD panels.

2.4 Orderable part numbers

The following table summarizes the part numbers of the devices covered by this document.

Table 2-11. Orderable part numbers summary

Freescale part number	CPU frequency	Pin count	Package	Total flash memory	Program flash	EEPROM	SRAM	GPIO
MK40DN512ZVLL10	100 MHz	100	LQFP	512 KB	512 KB	—	128 KB	64

Chapter 3

Chip Configuration

3.1 Introduction

This chapter provides details on the individual modules of the microcontroller. It includes:

- module block diagrams showing immediate connections within the device,
- specific module-to-module interactions not necessarily discussed in the individual module chapters, and
- links for more information.

3.2 Core modules

3.2.1 ARM Cortex-M4 Core Configuration

This section summarizes how the module has been configured in the chip. Full documentation for this module is provided by ARM and can be found at <http://www.arm.com>.

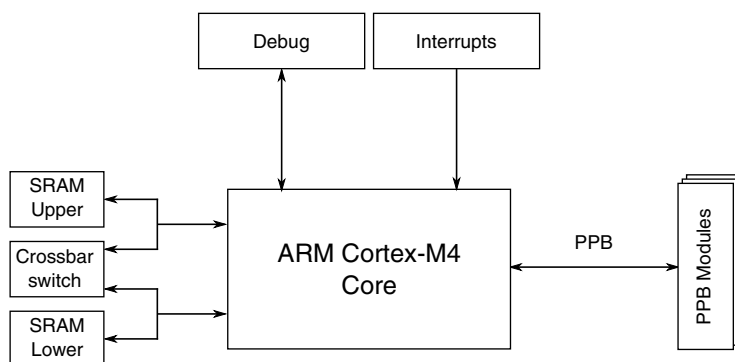

Figure 3-1. Core configuration

Table 3-1. Reference links to related information

Topic	Related module	Reference
Full description	ARM Cortex-M4 core, r0p0	http://www.arm.com
System memory map		System memory map
Clocking		Clock distribution
Power management		Power management
System/instruction/data bus module	Crossbar switch	Crossbar switch
System/instruction/data bus module	SRAM	SRAM
Debug	IEEE 1149.1 JTAG IEEE 1149.7 JTAG (cJTAG) Serial Wire Debug (SWD) ARM Real-Time Trace Interface	Debug
Interrupts	Nested Vectored Interrupt Controller (NVIC)	NVIC
Private Peripheral Bus (PPB) module	Miscellaneous Control Module (MCM)	MCM

3.2.1.1 Buses, interconnects, and interfaces

The ARM Cortex-M4 core has four buses as described in the following table.

Bus name	Description
Instruction code (ICODE) bus	The ICODE and DCODE buses are muxed. This muxed bus is called the CODE bus and is connected to the crossbar switch via a single master port. In addition, the CODE bus is also tightly coupled to the lower half of the system RAM (SRAM_L).
Data code (DCODE) bus	
System bus	The system bus is connected to a separate master port on the crossbar. In addition, the system bus is tightly coupled to the upper half system RAM (SRAM_U).
Private peripheral (PPB) bus	The PPB provides access to these modules: <ul style="list-style-type: none"> • ARM modules such as the NVIC, ETM, ITM, DWT, FBP, and ROM table • Freescale Miscellaneous Control Module (MCM)

3.2.1.2 System Tick Timer

The System Tick Timer's clock source is always the core clock, FCLK. This results in the following:

- The CLKSOURCE bit in SysTick Control and Status register is always set to select the core clock.
- Because the timing reference (FCLK) is a variable frequency, the TENMS bit in the SysTick Calibration Value Register is always zero.
- The NOREF bit in SysTick Calibration Value Register is always set, implying that FCLK is the only available source of reference timing.

3.2.1.3 Debug facilities

This device has extensive debug capabilities including run control and tracing capabilities. The standard ARM debug port that supports JTAG and SWD interfaces. Also the cJTAG interface is supported on this device.

3.2.1.4 Core privilege levels

The ARM documentation uses different terms than this document to distinguish between privilege levels.

If you see this term...	it also means this term...
Privileged	Supervisor
Unprivileged or user	User

3.2.2 Nested Vectored Interrupt Controller (NVIC) Configuration

This section summarizes how the module has been configured in the chip. Full documentation for this module is provided by ARM and can be found at <http://www.arm.com>.

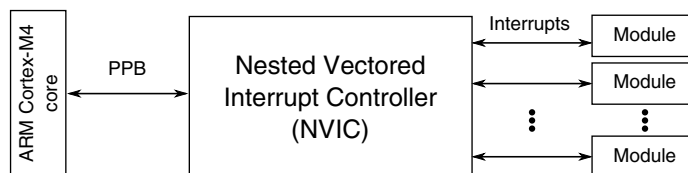

Figure 3-2. NVIC configuration

Table 3-2. Reference links to related information

Topic	Related module	Reference
Full description	Nested Vectored Interrupt Controller (NVIC)	http://www.arm.com
System memory map		System memory map
Clocking		Clock distribution
Power management		Power management
Private Peripheral Bus (PPB)	ARM Cortex-M4 core	ARM Cortex-M4 core

3.2.2.1 Interrupt priority levels

This device supports 16 priority levels for interrupts. Therefore, in the NVIC each source in the IPR registers contains 4 bits. For example, IPR0 is shown below:

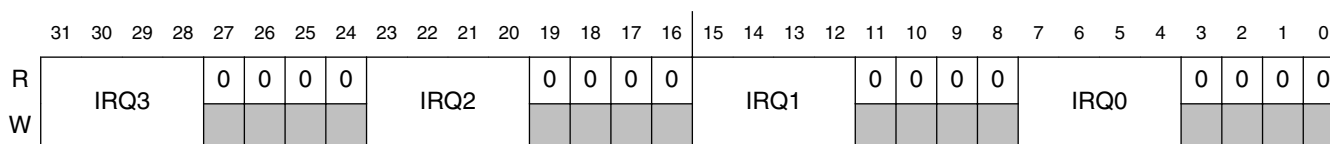

3.2.2.2 Non-maskable interrupt

The non-maskable interrupt request to the NVIC is controlled by the external $\overline{\text{NMI}}$ signal. The pin the $\overline{\text{NMI}}$ signal is multiplexed on, must be configured for the $\overline{\text{NMI}}$ function to generate the non-maskable interrupt request.

3.2.2.3 Interrupt channel assignments

The interrupt source assignments are defined in the following table.

- Vector number — the value stored on the stack when an interrupt is serviced.
- IRQ number — non-core interrupt source count, which is the vector number minus 16.

The IRQ number is used within ARM's NVIC documentation.

Table 3-4. Interrupt vector assignments

Address	Vector	IRQ ¹	NVIC non-IPR register number ²	NVIC IPR register number ³	Source module	Source description
ARM Core System Handler Vectors						
0x0000_0000	0	—	—	—	ARM core	Initial Stack Pointer
0x0000_0004	1	—	—	—	ARM core	Initial Program Counter
0x0000_0008	2	—	—	—	ARM core	Non-maskable Interrupt (NMI)
0x0000_000C	3	—	—	—	ARM core	Hard Fault
0x0000_0010	4	—	—	—	ARM core	MemManage Fault
0x0000_0014	5	—	—	—	ARM core	Bus Fault
0x0000_0018	6	—	—	—	ARM core	Usage Fault
0x0000_001C	7	—	—	—	—	—
0x0000_0020	8	—	—	—	—	—
0x0000_0024	9	—	—	—	—	—
0x0000_0028	10	—	—	—	—	—
0x0000_002C	11	—	—	—	ARM core	Supervisor call (SVCall)
0x0000_0030	12	—	—	—	ARM core	Debug Monitor
0x0000_0034	13	—	—	—	—	—
0x0000_0038	14	—	—	—	ARM core	Pendable request for system service (PendableSrvReq)
0x0000_003C	15	—	—	—	ARM core	System tick timer (SysTick)
Non-Core Vectors						
0x0000_0040	16	0	0	0	DMA	DMA channel 0 transfer complete
0x0000_0044	17	1	0	0	DMA	DMA channel 1 transfer complete
0x0000_0048	18	2	0	0	DMA	DMA channel 2 transfer complete
0x0000_004C	19	3	0	0	DMA	DMA channel 3 transfer complete
0x0000_0050	20	4	0	1	DMA	DMA channel 4 transfer complete

Table continues on the next page...

Table 3-4. Interrupt vector assignments (continued)

Address	Vector	IRQ ¹	NVIC non-IPR register number ²	NVIC IPR register number ³	Source module	Source description
0x0000_0054	21	5	0	1	DMA	DMA channel 5 transfer complete
0x0000_0058	22	6	0	1	DMA	DMA channel 6 transfer complete
0x0000_005C	23	7	0	1	DMA	DMA channel 7 transfer complete
0x0000_0060	24	8	0	2	DMA	DMA channel 8 transfer complete
0x0000_0064	25	9	0	2	DMA	DMA channel 9 transfer complete
0x0000_0068	26	10	0	2	DMA	DMA channel 10 transfer complete
0x0000_006C	27	11	0	2	DMA	DMA channel 11 transfer complete
0x0000_0070	28	12	0	3	DMA	DMA channel 12 transfer complete
0x0000_0074	29	13	0	3	DMA	DMA channel 13 transfer complete
0x0000_0078	30	14	0	3	DMA	DMA channel 14 transfer complete
0x0000_007C	31	15	0	3	DMA	DMA channel 15 transfer complete
0x0000_0080	32	16	0	4	DMA	DMA error interrupt channels 0-15
0x0000_0084	33	17	0	4	MCM	Normal interrupt
0x0000_0088	34	18	0	4	Flash memory	Command complete
0x0000_008C	35	19	0	4	Flash memory	Read collision
0x0000_0090	36	20	0	5	Mode Controller	Low-voltage detect, low-voltage warning
0x0000_0094	37	21	0	5	LLWU	Low Leakage Wakeup NOTE: The LLWU interrupt must not be masked by the interrupt controller to avoid a scenario where the system does not fully exit stop mode on an LLS recovery.
0x0000_0098	38	22	0	5	WDOG	Watchdog interrupt
0x0000_009C	39	23	0	5	—	—
0x0000_00A0	40	24	0	6	I ² C0	—
0x0000_00A4	41	25	0	6	I ² C1	—
0x0000_00A8	42	26	0	6	SPI0	Single interrupt vector for all sources
0x0000_00AC	43	27	0	6	SPI1	Single interrupt vector for all sources
0x0000_00B0	44	28	0	7	SPI2	Single interrupt vector for all sources
0x0000_00B4	45	29	0	7	CAN0	OR'ed Message buffer (0-15)
0x0000_00B8	46	30	0	7	CAN0	Bus Off
0x0000_00BC	47	31	0	7	CAN0	Error
0x0000_00C0	48	32	1	8	CAN0	Transmit Warning

Table continues on the next page...

Table 3-4. Interrupt vector assignments (continued)

Address	Vector	IRQ ¹	NVIC non-IPR register number ²	NVIC IPR register number ³	Source module	Source description
0x0000_00C4	49	33	1	8	CAN0	Receive Warning
0x0000_00C8	50	34	1	8	CAN0	Wake Up
0x0000_00CC	51	35	1	8	—	—
0x0000_00D0	52	36	1	9	—	—
0x0000_00D4	53	37	1	9	CAN1	OR'ed Message buffer (0-15)
0x0000_00D8	54	38	1	9	CAN1	Bus off
0x0000_00DC	55	39	1	9	CAN1	Error
0x0000_00E0	56	40	1	10	CAN1	Transmit Warning
0x0000_00E4	57	41	1	10	CAN1	Receive Warning
0x0000_00E8	58	42	1	10	CAN1	Wake Up
0x0000_00EC	59	43	1	10	—	—
0x0000_00F0	60	44	1	11	—	—
0x0000_00F4	61	45	1	11	UART0	Single interrupt vector for UART status sources
0x0000_00F8	62	46	1	11	UART0	Single interrupt vector for UART error sources
0x0000_00FC	63	47	1	11	UART1	Single interrupt vector for UART status sources
0x0000_0100	64	48	1	12	UART1	Single interrupt vector for UART error sources
0x0000_0104	65	49	1	12	UART2	Single interrupt vector for UART status sources
0x0000_0108	66	50	1	12	UART2	Single interrupt vector for UART error sources
0x0000_010C	67	51	1	12	UART3	Single interrupt vector for UART status sources
0x0000_0110	68	52	1	13	UART3	Single interrupt vector for UART error sources
0x0000_0114	69	53	1	13	UART4	Single interrupt vector for UART status sources
0x0000_0118	70	54	1	13	UART4	Single interrupt vector for UART error sources
0x0000_011C	71	55	1	13	—	—
0x0000_0120	72	56	1	14	—	—
0x0000_0124	73	57	1	14	ADC0	—
0x0000_0128	74	58	1	14	ADC1	—

Table continues on the next page...

Table 3-4. Interrupt vector assignments (continued)

Address	Vector	IRQ ¹	NVIC non-IPR register number ²	NVIC IPR register number ³	Source module	Source description
0x0000_012C	75	59	1	14	CMP0	—
0x0000_0130	76	60	1	15	CMP1	—
0x0000_0134	77	61	1	15	CMP2	—
0x0000_0138	78	62	1	15	FTM0	Single interrupt vector for all sources
0x0000_013C	79	63	1	15	FTM1	Single interrupt vector for all sources
0x0000_0140	80	64	2	16	FTM2	Single interrupt vector for all sources
0x0000_0144	81	65	2	16	CMT	—
0x0000_0148	82	66	2	16	RTC	Alarm interrupt
0x0000_014C	83	67	2	16	—	—
0x0000_0150	84	68	2	17	PIT	Channel 0
0x0000_0154	85	69	2	17	PIT	Channel 1
0x0000_0158	86	70	2	17	PIT	Channel 2
0x0000_015C	87	71	2	17	PIT	Channel 3
0x0000_0160	88	72	2	18	PDB	—
0x0000_0164	89	73	2	18	USB OTG	—
0x0000_0168	90	74	2	18	USB Charger Detect	—
0x0000_016C	91	75	2	18	—	—
0x0000_0170	92	76	2	19	—	—
0x0000_0174	93	77	2	19	—	—
0x0000_0178	94	78	2	19	—	—
0x0000_017C	95	79	2	19	I ² S0	—
0x0000_0180	96	80	2	20	SDHC	—
0x0000_0184	97	81	2	20	DAC0	—
0x0000_0188	98	82	2	20	—	—
0x0000_018C	99	83	2	20	TSI	Single interrupt vector for all sources
0x0000_0190	100	84	2	21	MCG	—
0x0000_0194	101	85	2	21	Low Power Timer	—
0x0000_0198	102	86	2	21	Segment LCD	Single interrupt vector for all sources
0x0000_019C	103	87	2	21	Port control module	Pin detect (Port A)
0x0000_01A0	104	88	2	22	Port control module	Pin detect (Port B)

Table continues on the next page...

Table 3-4. Interrupt vector assignments (continued)

Address	Vector	IRQ ¹	NVIC non-IPR register number ²	NVIC IPR register number ³	Source module	Source description
0x0000_01A4	105	89	2	22	Port control module	Pin detect (Port C)
0x0000_01A8	106	90	2	22	Port control module	Pin detect (Port D)
0x0000_01AC	107	91	2	22	Port control module	Pin detect (Port E)
0x0000_01B0	108	92	2	23	—	—
0x0000_01B4	109	93	2	23	—	—
0x0000_01B8	110	94	2	23	Software	Software interrupt ⁴

1. Indicates the NVIC's interrupt source number.
2. Indicates the NVIC's ISER, ICER, ISPR, ICPR, and IABR register number used for this IRQ. The equation to calculate this value is: $IRQ \div 32$
3. Indicates the NVIC's IPR register number used for this IRQ. The equation to calculate this value is: $IRQ \div 4$
4. This interrupt can only be pended or cleared via the NVIC registers.

3.2.2.3.1 Determining the bitfield and register location for configuring a particular interrupt

Suppose you need to configure the low-power timer (LPTMR) interrupt. The following table is an excerpt of the LPTMR row from [Interrupt channel assignments](#).

Table 3-5. LPTMR interrupt vector assignment

Address	Vector	IRQ ¹	NVIC non-IPR register number ²	NVIC IPR register number ³	Source module	Source description
0x0000_0194	101	85	2	21	Low Power Timer	—

1. Indicates the NVIC's interrupt source number.
2. Indicates the NVIC's ISER, ICER, ISPR, ICPR, and IABR register number used for this IRQ. The equation to calculate this value is: $IRQ \div 32$
3. Indicates the NVIC's IPR register number used for this IRQ. The equation to calculate this value is: $IRQ \div 4$

- The NVIC registers you would use to configure the interrupt are:
 - NVICISER2
 - NVICICER2
 - NVICISPR2
 - NVICICPR2

- NVICIABR2
- NVICIPR21
- To determine the particular IRQ's bitfield location within these particular registers:
 - NVICISER2, NVICICER2, NVICISPR2, NVICICPR2, NVICIABR2 bit location = $IRQ \bmod 32 = 21$
 - NVICIPR21 bitfield starting location = $8 * (IRQ \bmod 4) + 4 = 12$

Since the NVICIPR bitfields are 4-bit wide (16 priority levels), the NVICIPR21 bitfield range is 12-15

Therefore, the following bitfield locations are used to configure the LPTMR interrupts:

- NVICISER2[21]
- NVICICER2[21]
- NVICISPR2[21]
- NVICICPR2[21]
- NVICIABR2[21]
- NVICIPR21[15:12]

3.2.3 Asynchronous Wake-up Interrupt Controller (AWIC) Configuration

This section summarizes how the module has been configured in the chip. Full documentation for this module is provided by ARM and can be found at <http://www.arm.com>.

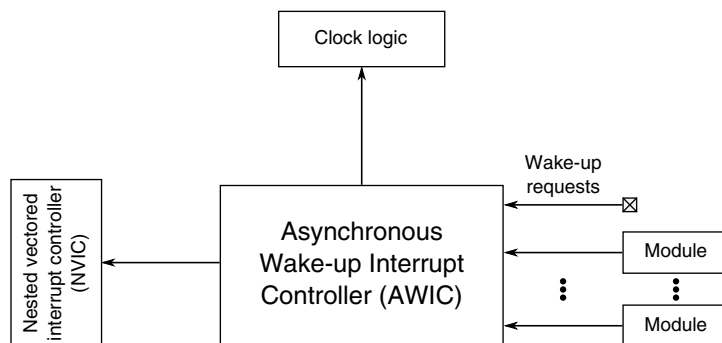

Figure 3-3. Asynchronous Wake-up Interrupt Controller configuration

Table 3-6. Reference links to related information

Topic	Related module	Reference
System memory map		System memory map
Clocking		Clock distribution

Table continues on the next page...

Table 3-6. Reference links to related information (continued)

Topic	Related module	Reference
Power management		Power management
	Nested Vectored Interrupt Controller (NVIC)	NVIC
Wake-up requests		AWIC wake-up sources

3.2.3.1 Wake-up sources

The device uses the following internal and external inputs to the AWIC module.

Table 3-7. AWIC Stop and VLPS Wake-up Sources

Wake-up source	Description
Available system resets	RESET pin and WDOG when LPO is its clock source, and JTAG
Low-voltage detect	Mode Controller
Low-voltage warning	Mode Controller
Pin interrupts	Port Control Module - Any enabled pin interrupt is capable of waking the system
ADCx	The ADC is functional when using internal clock source
CMPx	Since no system clocks are available, functionality is limited
I ² C	Address match wakeup
UART	Active edge on RXD
USB	Wakeup
LPTMR	Functional in Stop/VLPS modes
RTC	Functional in Stop/VLPS modes
SDHC	Wakeup
I2S	Wakeup
TSI	
CAN	
Segment LCD	
Tamper detect	Interrupt or a reset

3.2.4 JTAG Controller Configuration

This section summarizes how the module has been configured in the chip. For a comprehensive description of the module itself, see the module's dedicated chapter.

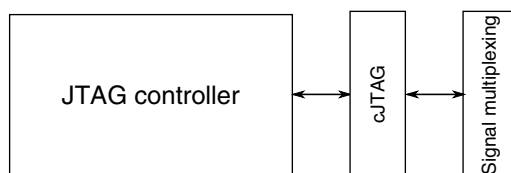

Figure 3-4. JTAGC Controller configuration

Table 3-8. Reference links to related information

Topic	Related module	Reference
Full description	JTAGC	JTAGC
Signal multiplexing	Port control	Signal multiplexing

3.3 System modules

3.3.1 SIM Configuration

This section summarizes how the module has been configured in the chip. For a comprehensive description of the module itself, see the module’s dedicated chapter.

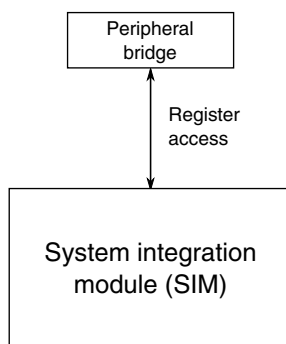

Figure 3-5. SIM configuration

Table 3-9. Reference links to related information

Topic	Related module	Reference
Full description	SIM	SIM
System memory map		System memory map
Clocking		Clock distribution
Power management		Power management

3.3.2 Mode Controller Configuration

This section summarizes how the module has been configured in the chip. For a comprehensive description of the module itself, see the module's dedicated chapter.

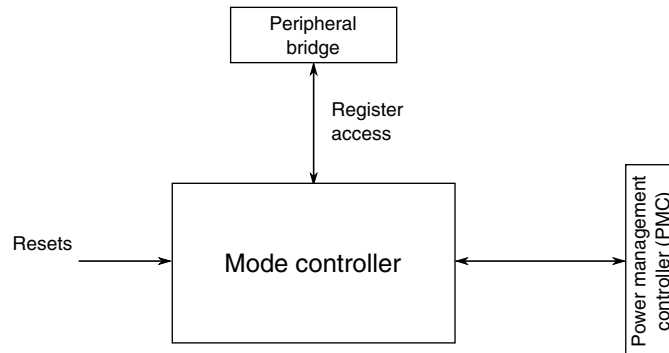

Figure 3-6. Mode controller configuration

Table 3-10. Reference links to related information

Topic	Related module	Reference
Full description	Mode Controller	Mode Controller
System memory map		System memory map
Power management		Power management
Power management controller (PMC)		PMC

3.3.3 PMC Configuration

This section summarizes how the module has been configured in the chip. For a comprehensive description of the module itself, see the module's dedicated chapter.

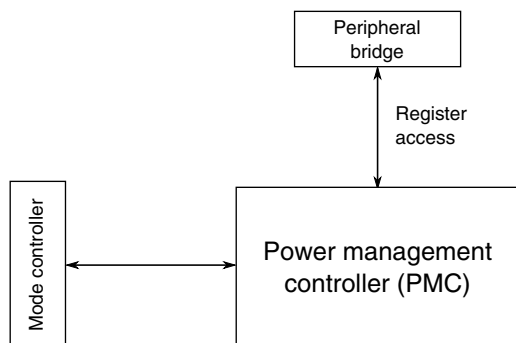

Figure 3-7. PMC configuration

Table 3-11. Reference links to related information

Topic	Related module	Reference
Full description	PMC	PMC
System memory map		System memory map
Power management		Power management
Full description	Mode Controller	Mode Controller
	Low-Leakage Wakeup Unit (LLWU)	LLWU

3.3.4 Low-Leakage Wake-up Unit (LLWU) Configuration

This section summarizes how the module has been configured in the chip. For a comprehensive description of the module itself, see the module’s dedicated chapter.

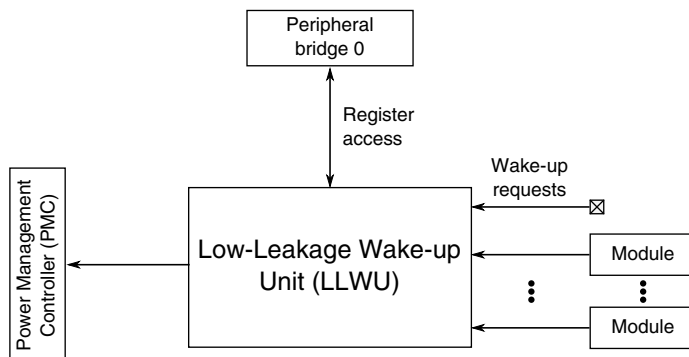

Figure 3-8. Low-Leakage Wake-up Unit configuration

Table 3-12. Reference links to related information

Topic	Related module	Reference
Full description	LLWU	LLWU
System memory map		System memory map

Table continues on the next page...

Table 3-12. Reference links to related information (continued)

Topic	Related module	Reference
Clocking		Clock distribution
Power management		Power management chapter
	Power Management Controller (PMC)	Power Management Controller (PMC)
	Mode Controller	Mode Controller
Wake-up requests		LLWU wake-up sources

3.3.4.1 Wake-up Sources

This chip uses the following internal peripheral and external pin inputs as wakeup sources to the LLWU module:

- LLWU_P0-15 are external pin inputs. See the chip's signal multiplexing table for the individual input signal options.
- LLWU_M0IF-M7IF are connections to the internal peripheral interrupt flags.

NOTE

$\overline{\text{RESET}}$ is also a wakeup source, depending on the bit setting in the LLWU_CS register. On devices where $\overline{\text{RESET}}$ is not a dedicated pin, it must also be enabled in the explicit port mux control.

Table 3-13. Wakeup sources for LLWU inputs

Input	Wakeup source	Input	Wakeup source
LLWU_P0	PTE1/LLWU_P0 pin	LLWU_P12	PTD0/LLWU_P12 pin
LLWU_P1	PTE2/LLWU_P1 pin	LLWU_P13	PTD2/LLWU_P13 pin
LLWU_P2	PTE4/LLWU_P2 pin	LLWU_P14	PTD4/LLW14_P0 pin
LLWU_P3	PTA4/LLWU_P3 pin ¹	LLWU_P15	PTD6/LLWU_P15 pin
LLWU_P4	PTA13/LLWU_P4 pin	LLWU_M0IF	LPTMR ²
LLWU_P5	PTB0/LLWU_P5 pin	LLWU_M1IF	CMP0 ²
LLWU_P6	PTC1/LLWU_P6 pin	LLWU_M2IF	CMP1 ²
LLWU_P7	PTC3/LLWU_P7 pin	LLWU_M3IF	CMP2 ²
LLWU_P8	PTC4/LLWU_P8 pin	LLWU_M4IF	TSI ²
LLWU_P9	PTC5/LLWU_P9 pin	LLWU_M5IF	RTC Alarm ²
LLWU_P10	PTC6/LLWU_P10 pin	LLWU_M6IF	ReservedDryIce (tamper detect) ²
LLWU_P11	PTC11/LLWU_P11 pin	LLWU_M7IF	Error Detect - wake-up source unknown

1. A falling edge input that remains low on this pin when waking up the MCU from VLLSx modes with the EzPort enabled causes entry into EzPort mode during the reset sequence. A falling edge input that remains low on this pin when waking

System modules

up the MCU from any non-VLLSx mode with the NMI function selected in its port control register asserts an NMI exception on low power mode recovery. The same occurs when recovering from VLLSx modes if EzPort is disabled; otherwise, EzPort mode is entered. See the "EzPort Configuration" section in this chapter for more information.

- Requires the peripheral and the peripheral interrupt to be enabled. The LLWU's WUME bit enables the internal module flag as a wakeup input. After wakeup, the flags are cleared based on the peripheral clearing mechanism.

3.3.5 MCM Configuration

This section summarizes how the module has been configured in the chip. For a comprehensive description of the module itself, see the module's dedicated chapter.

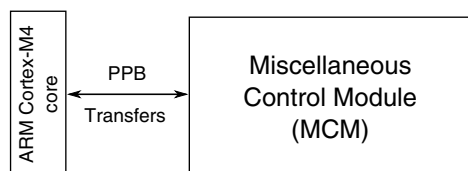

Figure 3-9. MCM configuration

Table 3-14. Reference links to related information

Topic	Related module	Reference
Full description	Miscellaneous control module (MCM)	MCM
System memory map		System memory map
Clocking		Clock distribution
Power management		Power management
Transfers Private Peripheral Bus (PPB)	ARM Cortex-M4 core	ARM Cortex-M4 core

3.3.6 Crossbar Switch Configuration

This section summarizes how the module has been configured in the chip. For a comprehensive description of the module itself, see the module's dedicated chapter.

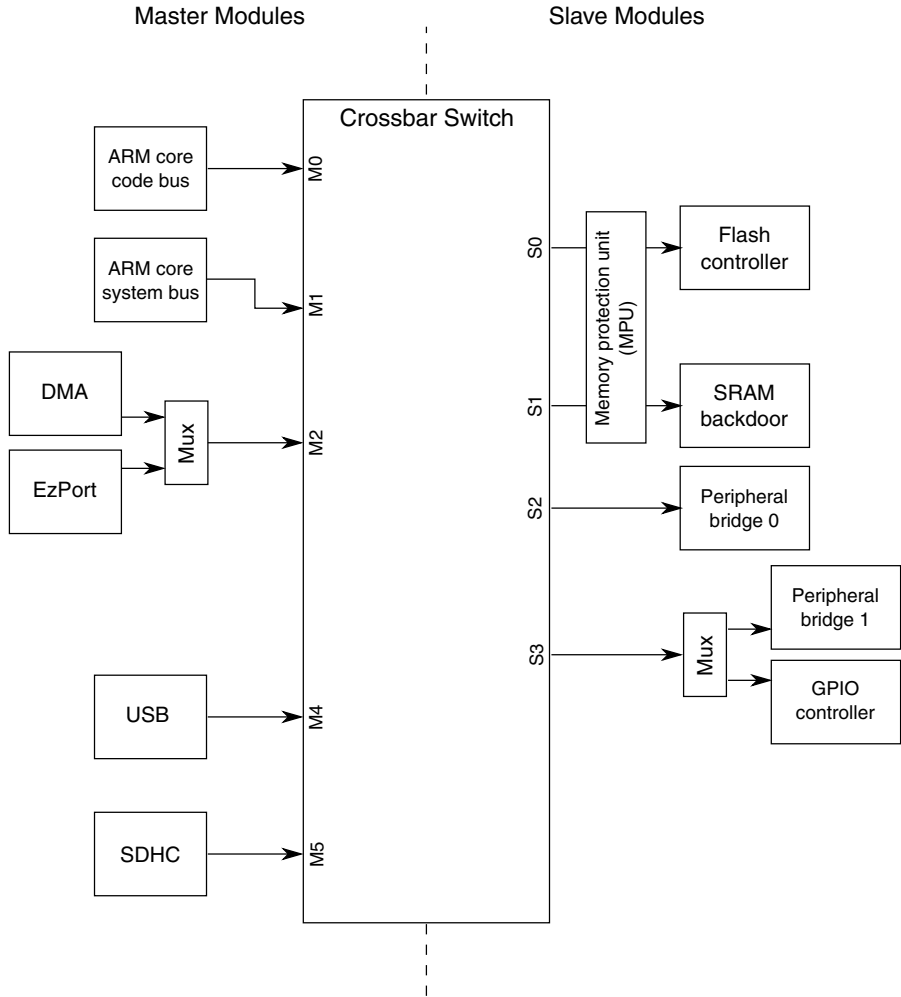

Figure 3-10. Crossbar switch integration

Table 3-15. Reference links to related information

Topic	Related module	Reference
Full description	Crossbar switch	Crossbar Switch
System memory map		System memory map
Clocking		Clock Distribution
Memory protection	MPU	MPU
Crossbar switch master	ARM Cortex-M4 core	ARM Cortex-M4 core
Crossbar switch master	DMA controller	DMA controller
Crossbar switch master	EzPort	EzPort
Crossbar switch master	USB FS/LS	USB FS/LS
Crossbar switch master	SDHC	SDHC
Crossbar switch slave	Flash	Flash
Crossbar switch slave	SRAM backdoor	SRAM backdoor
Crossbar switch slave	Peripheral bridges	Peripheral bridge

Table continues on the next page...

Table 3-15. Reference links to related information (continued)

Topic	Related module	Reference
Crossbar switch slave	GPIO controller	GPIO controller

3.3.6.1 Crossbar Switch Master Assignments

The masters connected to the crossbar switch are assigned as follows:

Master module	Master port number
ARM core code bus	0
ARM core system bus	1
DMA/EzPort	2
USB OTG	4
SDHC	5

NOTE

The DMA and EzPort share a master port. Since these modules never operate at the same time, no configuration or arbitration explanations are necessary.

3.3.6.2 Crossbar Switch Slave Assignments

The slaves connected to the crossbar switch are assigned as follows:

Slave module	Slave port number	Protected by MPU?
Flash memory controller	0	Yes
SRAM backdoor	1	Yes
Peripheral bridge 0 ¹	2	No. Protection built into bridge.
Peripheral bridge 1/GPIO ¹	3	No. Protection built into bridge.

1. See [System memory map](#) for access restrictions.

3.3.6.3 PRS register reset values

The AXBS_PRSn registers reset to 0054_3210h.

3.3.7 Memory Protection Unit (MPU) Configuration

This section summarizes how the module has been configured in the chip. For a comprehensive description of the module itself, see the module’s dedicated chapter.

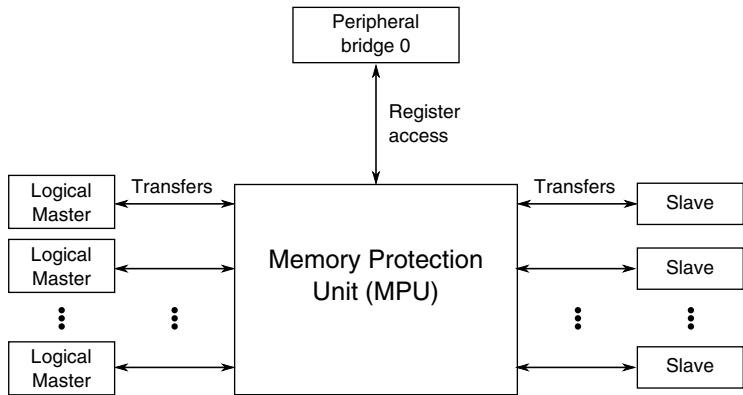

Figure 3-11. Memory Protection Unit configuration

Table 3-16. Reference links to related information

Topic	Related module	Reference
Full description	Memory Protection Unit (MPU)	MPU
System memory map		System memory map
Clocking		Clock distribution
Power management		Power management
Logical masters		Logical master assignments
Slave modules		Slave module assignments

3.3.7.1 MPU Slave Port Assignments

The memory-mapped resources protected by the MPU are:

Table 3-17. MPU Slave Port Assignments

Source	MPU Slave Port Assignment	Destination
Crossbar slave port 0	MPU slave port 0	Flash Controller
Crossbar slave port 1	MPU slave port 1	SRAM backdoor
Code Bus	MPU slave port 2	SRAM_L frontdoor
System Bus	MPU slave port 3	SRAM_U frontdoor

3.3.7.2 MPU Logical Bus Master Assignments

The logical bus master assignments for the MPU are:

Table 3-18. MPU Logical Bus Master Assignments

MPU Logical Bus Master Number	Bus Master
0	Core
1	Debugger
2	DMA
3	none
4	USB
5	SDHC
6	none
7	none

3.3.7.3 MPU Access Violation Indications

Access violations detected by the MPU are signaled to the appropriate bus master as shown below:

Table 3-19. Access Violation Indications

Bus Master	Core Indication
Core	Bus fault (interrupt vector #5) Note: To enable bus faults set the core's System Handler Control and State Register's BUSFAULTENA bit. If this bit is not set, MPU violations result in a hard fault (interrupt vector #3).
Debugger	The STICKYERROR flag is set in the Debug Port Control/Status Register.
DMA	Interrupt vector #32
USB_OTG	Interrupt vector #89
SDHC	Interrupt vector #96

3.3.7.4 Reset Values for RGD0 Registers

At reset, the MPU is enabled with a single region descriptor (RGD0) that maps the entire 4 GB address space with read, write and execute permissions given to the core, debugger and the DMA bus masters.

The following table shows the chip-specific reset values for RGD0 and RGDAAC0.

Table 3-20. Reset Values for RGD0 Registers

Register	Reset value
RGD0_WORD0	0000_0000h
RGD0_WORD1	FFFF_FFFFh
RGD0_WORD2	0061_F7DFh
RGD0_WORD3	0000_0001h
RGDAAC0	0061_F7DFh

3.3.7.5 Write Access Restrictions for RGD0 Registers

In addition to configuring the initial state of RGD0, the MPU implements further access control on writes to the RGD0 registers. Specifically, the MPU assigns a priority scheme where the debugger is treated as the highest priority master followed by the core and then all the remaining masters.

The MPU does not allow writes from the core to affect the RGD0 start or end addresses nor the permissions associated with the debugger; it can only write the permission fields associated with the other masters.

These protections (summarized below) guarantee that the debugger always has access to the entire address space and those rights cannot be changed by the core or any other bus master.

Table 3-21. Write Access to RGD0 Registers

Bus Master	Write Access?
Core	Partial. The Core cannot write to the following registers or register fields: <ul style="list-style-type: none"> • RGD0_WORD0, RGD0_WORD1, RGD0_WORD3 • RGD0_WORD2[M1SM, M1UM] • RGDAAC0[M1SM, M1UM] NOTE: Changes to the RGD0_WORD2 alterable fields should be done via a write to RGDAAC0.
Debugger	Yes
All other masters	No

3.3.8 Peripheral Bridge Configuration

This section summarizes how the module has been configured in the chip. For a comprehensive description of the module itself, see the module's dedicated chapter.

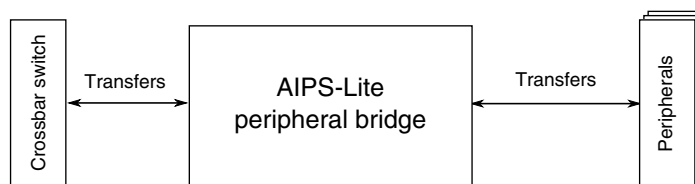

Figure 3-12. Peripheral bridge configuration

Table 3-22. Reference links to related information

Topic	Related module	Reference
Full description	Peripheral bridge (AIPS-Lite)	Peripheral bridge (AIPS-Lite)
System memory map		System memory map
Clocking		Clock Distribution
Crossbar switch	Crossbar switch	Crossbar switch

3.3.8.1 Number of peripheral bridges

This device contains two identical peripheral bridges.

3.3.8.2 Memory maps

The peripheral bridges are used to access the registers of most of the modules on this device. See [AIPS0 Memory Map](#) and [AIPS1 Memory Map](#) for the memory slot assignment for each module.

3.3.8.3 MPRA register

Each of the two peripheral bridges supports up to 8 crossbar switch masters, each assigned to a MPROTx field in the MPRA register. However, fewer are supported on this device. See [Crossbar switch](#) for details of the master port assignments for this device.

3.3.8.4 AIPS_Lite MPRA register reset value

- AIPS_x_MPRA reset value is 0x7770_0000

Therefore, masters 0, 1, and 2 are trusted bus masters after reset.

3.3.8.5 PACR registers

Each of the two peripheral bridges support up to 128 peripherals each assigned to an PACRx field within the PACRA-PACRP registers. However, fewer peripherals are supported on this device. See [AIPS0 Memory Map](#) and [AIPS1 Memory Map](#) for details of the peripheral slot assignments for this device. Unused PACRx fields are reserved.

3.3.8.6 AIPS_Lite PACRE-P register reset values

The AIPS_x_PACRE-P reset values depend on if the module is available on your particular device. For each populated slot in slots 32-127 in [Peripheral Bridge 0 \(AIPS-Lite 0\) Memory Map](#) and [Peripheral Bridge 1 \(AIPS-Lite 1\) Memory Map](#), the corresponding module's PACR[32:127] field resets to 0x4.

3.3.9 DMA request multiplexer configuration

This section summarizes how the module has been configured in the chip. For a comprehensive description of the module itself, see the module's dedicated chapter.

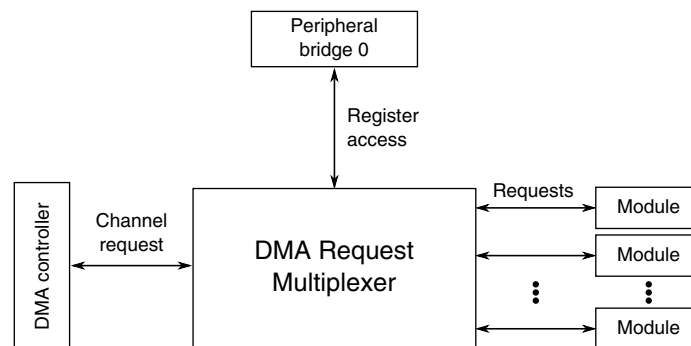

Figure 3-13. DMA request multiplexer configuration

Table 3-23. Reference links to related information

Topic	Related module	Reference
Full description	DMA request multiplexer	DMA Mux
System memory map		System memory map
Clocking		Clock distribution
Power management		Power management
Channel request	DMA controller	DMA Controller
Requests		DMA request sources

3.3.9.1 DMA MUX request sources

This device includes a DMA request mux that allows up to 63 DMA request signals to be mapped to any of the 16 DMA channels.

Because of the mux there is not a hard correlation between any of the DMA request sources and a specific DMA channel.

Table 3-24. DMA request sources - MUX 0

Source number	Source module	Source description
0	—	Channel disabled ¹
1	Reserved	Not used
2	UART0	Receive
3	UART0	Transmit
4	UART1	Receive
5	UART1	Transmit
6	UART2	Receive
7	UART2	Transmit
8	UART3	Receive
9	UART3	Transmit
10	UART4	Receive
11	UART4	Transmit
12	Reserved	—
13	Reserved	—
14	I ² S0	Receive
15	I ² S0	Transmit
16	SPI0	Receive
17	SPI0	Transmit
18	SPI1	Receive
19	SPI1	Transmit
20		
21		
22	I ² C0	—
23	I ² C1	—
24	FTM0	Channel 0
25	FTM0	Channel 1
26	FTM0	Channel 2

Table continues on the next page...

Table 3-24. DMA request sources - MUX 0 (continued)

Source number	Source module	Source description
27	FTM0	Channel 3
28	FTM0	Channel 4
29	FTM0	Channel 5
30	FTM0	Channel 6
31	FTM0	Channel 7
32	FTM1	Channel 0
33	FTM1	Channel 1
34	FTM2	Channel 0
35	FTM2	Channel 1
36	FTM3	Channel 0
37	FTM3	Channel 1
38	FTM3	Channel 2
39	FTM1	Channel 3
40	ADC0	—
41	ADC1	—
42	CMP0	—
43	CMP1	—
44	CMP2	—
45	DAC0	—
46	Reserved	—
47	CMT	—
48	PDB	—
49	Port control module	Port A
50	Port control module	Port B
51	Port control module	Port C
52	Port control module	Port D
53	Port control module	Port E
54	FTM3	Channel 4
55	FTM3	Channel 5
56	FTM3	Channel 6
57	FTM3	Channel 7
58	DMA MUX	Always enabled
59	DMA MUX	Always enabled
60	DMA MUX	Always enabled

Table continues on the next page...

Table 3-24. DMA request sources - MUX 0 (continued)

Source number	Source module	Source description
61	DMA MUX	Always enabled
62	DMA MUX	Always enabled
63	DMA MUX	Always enabled

1. Configuring a DMA channel to select source 0 or any of the reserved sources disables that DMA channel.

3.3.9.2 DMA transfers via PIT trigger

The PIT module can trigger a DMA transfer on the first four DMA channels. The assignments are detailed at [PIT/DMA Periodic Trigger Assignments](#).

3.3.10 DMA Controller Configuration

This section summarizes how the module has been configured in the chip. For a comprehensive description of the module itself, see the module’s dedicated chapter.

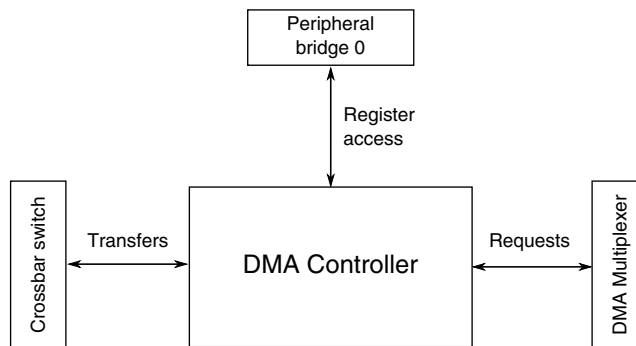

Figure 3-14. DMA Controller configuration

Table 3-25. Reference links to related information

Topic	Related module	Reference
Full description	DMA Controller	DMA Controller
System memory map		System memory map
Register access	Peripheral bridge (AIPS-Lite 0)	AIPS-Lite 0
Clocking		Clock distribution
Power management		Power management
Transfers	Crossbar switch	Crossbar switch

3.3.11 External Watchdog Monitor (EWM) Configuration

This section summarizes how the module has been configured in the chip. For a comprehensive description of the module itself, see the module’s dedicated chapter.

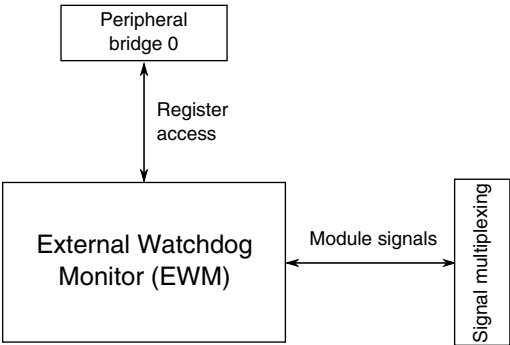

Figure 3-15. External Watchdog Monitor configuration

Table 3-26. Reference links to related information

Topic	Related module	Reference
Full description	External Watchdog Monitor (EWM)	EWM
System memory map		System memory map
Clocking		Clock distribution
Power management		Power management
Signal multiplexing	Port Control Module	Signal multiplexing

3.3.11.1 EWM clocks

This table shows the EWM clocks and the corresponding chip clocks.

Table 3-27. EWM clock connections

Module clock	Chip clock
Low Power Clock	1 kHz LPO Clock

3.3.11.2 EWM low-power modes

This table shows the EWM low-power modes and the corresponding chip low-power modes.

Table 3-28. EWM low-power modes

Module mode	Chip mode
Wait	Wait, VLPW
Stop	Stop, VLPS, LLS
Power Down	VLLS3, VLLS2, VLLS1

3.3.11.3 $\overline{\text{EWM_OUT}}$ pin state in low power modes

During Wait, Stop and Power Down modes the $\overline{\text{EWM_OUT}}$ pin enters a high-impedance state. A user has the option to control the logic state of the pin using an external pull device or by configuring the internal pull device. When the CPU enters a Run mode from Wait or Stop recovery, the pin resumes its previous state before entering Wait or Stop mode. When the CPU enters Run mode from Power Down, the pin returns to its reset state.

3.3.12 Watchdog Configuration

This section summarizes how the module has been configured in the chip. For a comprehensive description of the module itself, see the module’s dedicated chapter.

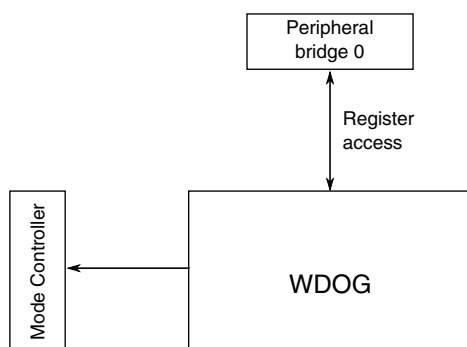

Figure 3-16. Watchdog configuration

Table 3-29. Reference links to related information

Topic	Related module	Reference
Full description	Watchdog	Watchdog
System memory map		System memory map
Clocking		Clock distribution
Power management		Power management
	Mode Controller (MC)	Mode Controller

3.3.12.1 WDOG clocks

This table shows the WDOG module clocks and the corresponding chip clocks.

Table 3-30. WDOG clock connections

Module clock	Chip clock
LPO Oscillator	1 kHz LPO Clock
Alt Clock	Bus Clock
Fast Test Clock	Bus Clock
System Bus Clock	Bus Clock

3.3.12.2 WDOG low-power modes

This table shows the WDOG low-power modes and the corresponding chip low-power modes.

Table 3-31. WDOG low-power modes

Module mode	Chip mode
Wait	Wait, VLPW
Standby	Stop, VLPS
Stop	Stop, VLPS
Power Down	LLS, VLLSx

NOTE

To enable the WDOG module when the chip is in Stop mode, write ones to both the STNDBYEN bit and the STOPEN bit of the Watchdog Status and Control Register High.

3.4 Clock Modules

3.4.1 MCG Configuration

This section summarizes how the module has been configured in the chip. For a comprehensive description of the module itself, see the module's dedicated chapter.

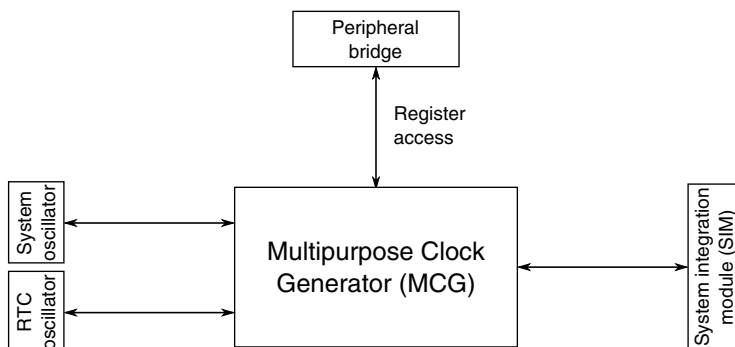

Figure 3-17. MCG configuration

Table 3-32. Reference links to related information

Topic	Related module	Reference
Full description	MCG	MCG
System memory map		System memory map
Clocking		Clock distribution
Power management		Power management
Signal multiplexing	Port control	Signal multiplexing

3.4.2 OSC Configuration

This section summarizes how the module has been configured in the chip. For a comprehensive description of the module itself, see the module’s dedicated chapter.

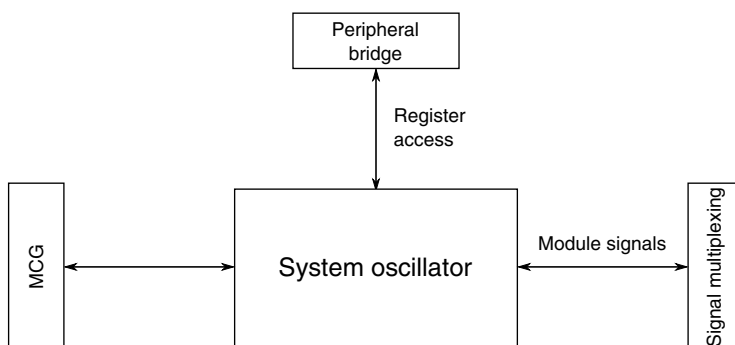

Figure 3-18. OSC configuration

Table 3-33. Reference links to related information

Topic	Related module	Reference
Full description	OSC	OSC
System memory map		System memory map
Clocking		Clock distribution

Table continues on the next page...

Table 3-33. Reference links to related information (continued)

Topic	Related module	Reference
Power management		Power management
Signal multiplexing	Port control	Signal multiplexing
Full description	MCG	MCG

3.4.2.1 OSC modes of operation with MCG

The MCG's C2 register bits configure the oscillator frequency range. See the OSC and MCG chapters for more details.

3.4.3 RTC OSC configuration

This section summarizes how the module has been configured in the chip. For a comprehensive description of the module itself, see the module's dedicated chapter.

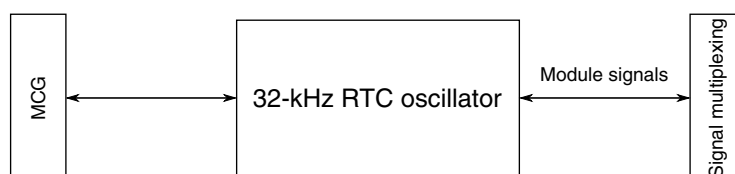
Figure 3-19. RTC OSC configuration
Table 3-34. Reference links to related information

Topic	Related module	Reference
Full description	RTC OSC	RTC OSC
Signal multiplexing	Port control	Signal multiplexing
Full description	MCG	MCG

3.5 Memories and Memory Interfaces

3.5.1 Flash Memory Configuration

This section summarizes how the module has been configured in the chip. For a comprehensive description of the module itself, see the module's dedicated chapter.

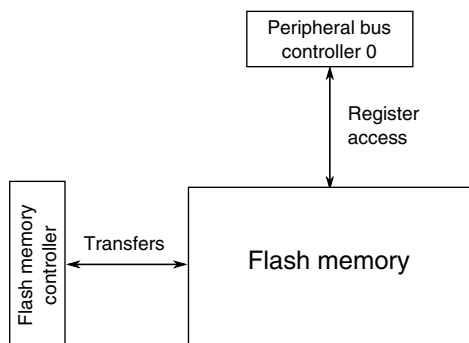

Figure 3-20. Flash memory configuration

Table 3-35. Reference links to related information

Topic	Related module	Reference
Full description	Flash memory	Flash memory
System memory map		System memory map
Clocking		Clock Distribution
Transfers	Flash memory controller	Flash memory controller
Register access	Peripheral bridge	Peripheral bridge

3.5.1.1 Flash memory types

This device contains the following types of flash memory:

- Program flash memory — non-volatile flash memory that can execute program code
- FlexMemory — encompasses the following memory types:
 - Programming acceleration RAM — RAM memory that accelerates flash programming

3.5.1.2 Flash Memory Sizes

The devices covered in this document contain:

- 2 blocks of program flash consisting of 2 KB sectors

The amounts of flash memory for the devices covered in this document are:

Device	Program flash (KB)	Block 0 (P-Flash) address range ¹	Block 1 (P-Flash) address range ¹
MK40DN512ZVLL10	512	0x0000_0000 – 0x0003_FFFF	0x0004_0000 – 0x0007_FFFF

1. The addresses shown assume program flash swap is disabled (default configuration).

3.5.1.3 Flash Memory Map

The various flash memories and the flash registers are located at different base addresses as shown in the following figure. The base address for each is specified in [System memory map](#).

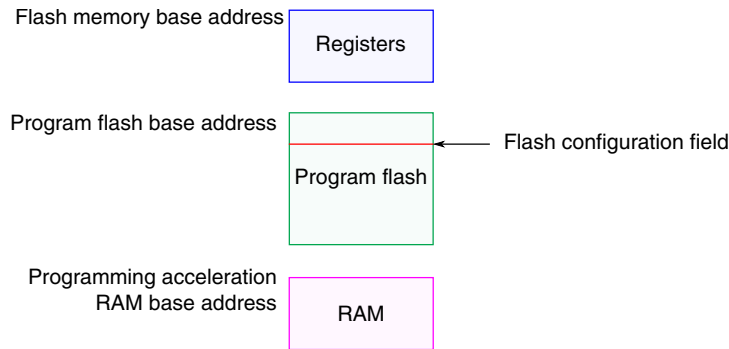

Figure 3-21. Flash memory map

3.5.1.4 Flash Security

How flash security is implemented on this device is described in [Chip Security](#).

3.5.1.5 Flash Modes

The flash memory operates in NVM normal and NVM special modes. The flash memory enters NVM special mode when the EzPort is enabled ($\overline{\text{EZP_CS}}$ asserted during reset), or the system is under debug mode. Otherwise, flash memory operates in NVM normal mode.

3.5.1.6 Erase All Flash Contents

In addition to software, the entire flash memory may be erased external to the flash memory in two ways:

1. Via the EzPort by issuing a bulk erase (BE) command. See the EzPort chapter for more details.
2. Via the SWJ-DP debug port by setting `DAP_CONTROL[0]`. `DAP_STATUS[0]` is set to indicate the mass erase command has been accepted. `DAP_STATUS[0]` is cleared when the mass erase completes.

3.5.1.7 FTFL_FOPT Register

The flash memory's FTFL_FOPT register allows the user to customize the operation of the MCU at boot time. See [FOPT boot options](#) for details of its definition.

3.5.2 Flash Memory Controller Configuration

This section summarizes how the module has been configured in the chip. For a comprehensive description of the module itself, see the module's dedicated chapter.

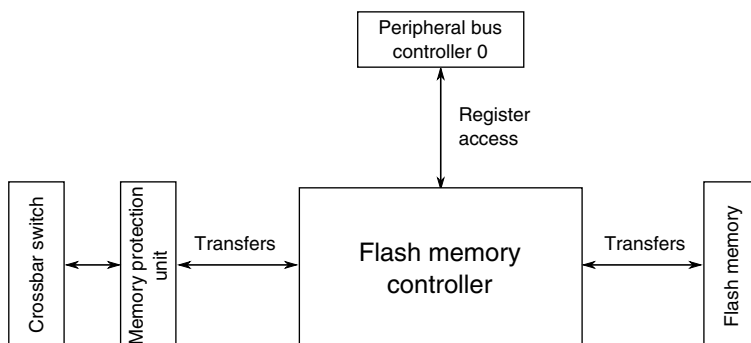

Figure 3-22. Flash memory controller configuration

Table 3-36. Reference links to related information

Topic	Related module	Reference
Full description	Flash memory controller	Flash memory controller
System memory map		System memory map
Clocking		Clock Distribution
Transfers	Flash memory	Flash memory
Transfers	MPU	MPU
Transfers	Crossbar switch	Crossbar Switch
Register access	Peripheral bridge	Peripheral bridge

3.5.2.1 Number of masters

The Flash Memory Controller supports up to eight crossbar switch masters. However, this device has a different number of crossbar switch masters. See [Crossbar Switch Configuration](#) for details on the master port assignments.

3.5.2.2 Program Flash Swap

On devices that contain program flash memory only, the program flash memory blocks may swap their base addresses.

While not using swap:

- FMC_PFB0CR controls the lower code addresses (block 0)
- FMC_PFB1CR controls the upper code addresses (block 1)

If swap is used, the opposite is true:

- FMC_PFB0CR controls the upper code addresses (now in block 0)
- FMC_PFB1CR controls the lower code addresses (now in block 1)

3.5.3 SRAM Configuration

This section summarizes how the module has been configured in the chip.

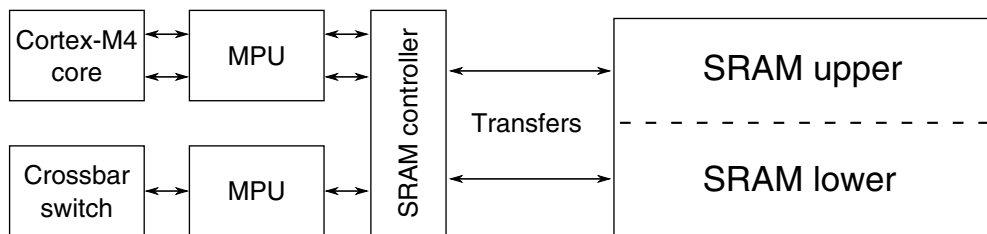

Figure 3-23. SRAM configuration

Table 3-37. Reference links to related information

Topic	Related module	Reference
Full description	SRAM	SRAM
System memory map		System memory map
Clocking		Clock Distribution
Transfers	SRAM controller	SRAM controller
	ARM Cortex-M4 core	ARM Cortex-M4 core
	Memory protection unit	Memory protection unit

3.5.3.1 SRAM sizes

This device contains SRAM tightly coupled to the ARM Cortex-M4 core. The amount of SRAM for the devices covered in this document is shown in the following table.

Device	SRAM (KB)
MK40DN512ZVLL10	128

3.5.3.2 SRAM Arrays

The on-chip SRAM is split into two equally-sized logical arrays, SRAM_L and SRAM_U.

The on-chip RAM is implemented such that the SRAM_L and SRAM_U ranges form a contiguous block in the memory map. As such:

- SRAM_L is anchored to 0x1FFF_FFFF and occupies the space before this ending address.
- SRAM_U is anchored to 0x2000_0000 and occupies the space after this beginning address.

Valid address ranges for SRAM_L and SRAM_U are then defined as:

- SRAM_L = [0x2000_0000-(SRAM_size/2)] to 0x1FFF_FFFF
- SRAM_U = 0x2000_0000 to [0x2000_0000+(SRAM_size/2)-1]

This is illustrated in the following figure.

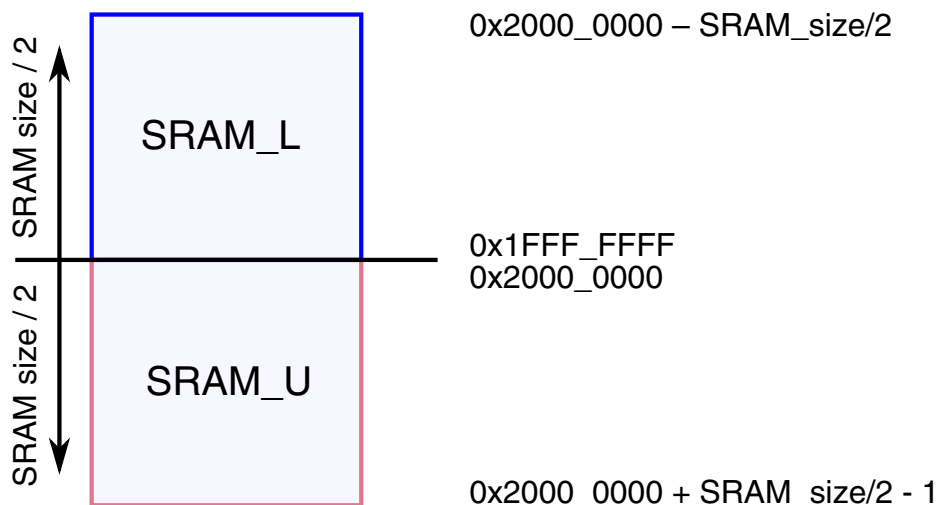

Figure 3-24. SRAM blocks memory map

For example, for a device containing 64 KB of SRAM the ranges are:

- SRAM_L: 0x1FFF_8000 – 0x1FFF_FFFF
- SRAM_U: 0x2000_0000 – 0x2000_7FFF

3.5.3.3 SRAM retention in low power modes

The SRAM is retained down to VLLS3 mode.

In VLLS2 the 4 KB region of SRAM_U from 0x2000_0000 is powered.

In VLLS1 no SRAM is retained. However, the [32-byte register file](#) is available in VLLS1.

3.5.3.4 SRAM accesses

The SRAM is split into two logical arrays that are 32-bits wide.

- SRAM_L — Accessible by the code bus of the Cortex-M4 core and by the backdoor port.
- SRAM_U — Accessible by the system bus of the Cortex-M4 core and by the backdoor port.

The backdoor port makes the SRAM accessible to the non-core bus masters (such as DMA).

The following figure illustrates the SRAM accesses within the device.

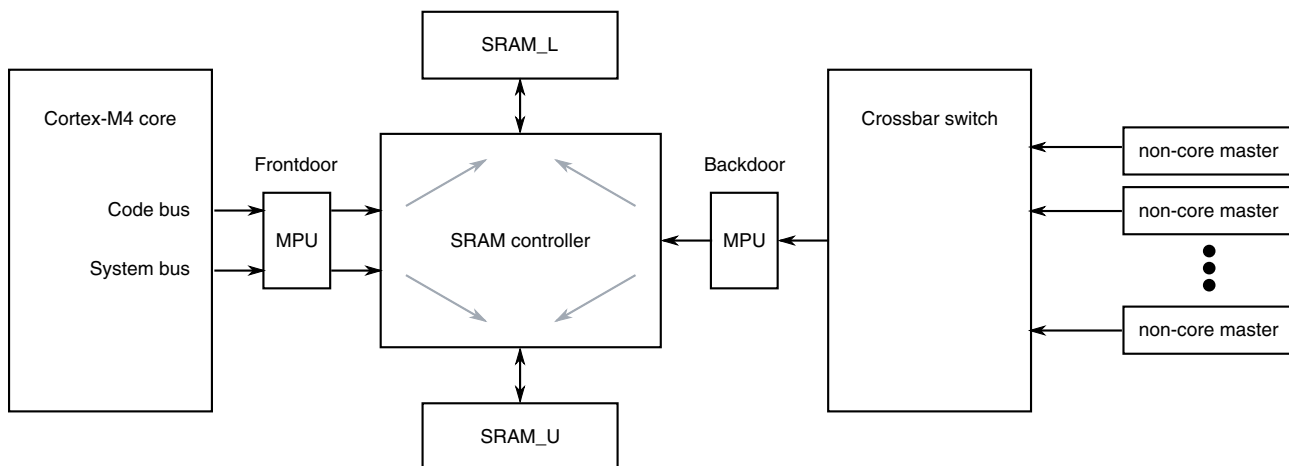

Figure 3-25. SRAM access diagram

The following simultaneous accesses can be made to different logical halves of the SRAM:

- Core code and core system
- Core code and non-core master
- Core system and non-core master

NOTE

Two non-core masters cannot access SRAM simultaneously.
The required arbitration and serialization is provided by the

crossbar switch. The SRAM_{L,U} arbitration is controlled by the SRAM controller based on the configuration bits in the MCM module.

NOTE

Burst-access cannot occur across the 0x2000_0000 boundary that separates the two SRAM arrays. The two arrays should be treated as separate memory ranges for burst accesses.

3.5.3.5 SRAM arbitration and priority control

The MCM's SRAMAP register controls the arbitration and priority schemes for the two SRAM arrays.

3.5.4 SRAM Controller Configuration

This section summarizes how the module has been configured in the chip.

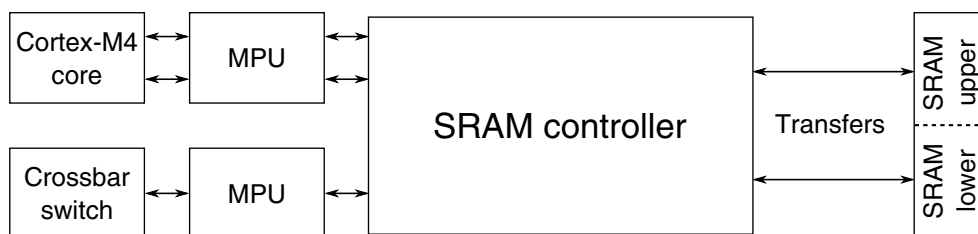

Figure 3-26. SRAM controller configuration

Table 3-38. Reference links to related information

Topic	Related module	Reference
System memory map		System memory map
Power management		Power management
Power management controller (PMC)		PMC
Transfers	SRAM	SRAM
	ARM Cortex-M4 core	ARM Cortex-M4 core
	MPU	Memory protection unit
Configuration	MCM	MCM

3.5.5 System Register File Configuration

This section summarizes how the module has been configured in the chip.

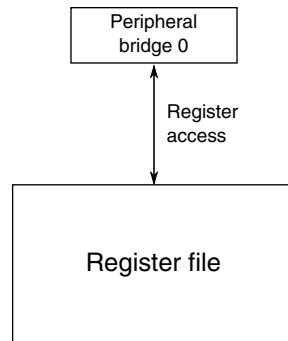

Figure 3-27. System Register file configuration

Table 3-39. Reference links to related information

Topic	Related module	Reference
Full description	Register file	Register file
System memory map		System memory map
Clocking		Clock distribution
Power management		Power management

3.5.5.1 System Register file

This device includes a 32-byte register file that is powered in all power modes.

Also, it retains contents during low-voltage detect (LVD) events and is only reset during a power-on reset.

3.5.6 VBAT Register File Configuration

This section summarizes how the module has been configured in the chip.

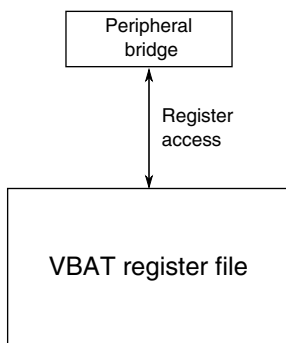

Figure 3-28. VBAT Register file configuration

Table 3-40. Reference links to related information

Topic	Related module	Reference
Full description	VBAT register file	VBAT register file
System memory map		System memory map
Clocking		Clock distribution
Power management		Power management

3.5.6.1 VBAT register file

This device includes a 32-byte register file that is powered in all power modes and is powered by VBAT.

It is only reset during VBAT power-on reset.

3.5.7 EzPort Configuration

This section summarizes how the module has been configured in the chip. For a comprehensive description of the module itself, see the module’s dedicated chapter.



Figure 3-29. EzPort configuration

Table 3-41. Reference links to related information

Topic	Related module	Reference
Full description	EzPort	EzPort

Table continues on the next page...

Table 3-41. Reference links to related information (continued)

Topic	Related module	Reference
System memory map		System memory map
Clocking		Clock Distribution
Transfers	Crossbar switch	Crossbar switch
Signal Multiplexing	Port control	Signal Multiplexing

3.5.7.1 JTAG instruction

The system JTAG controller implements an EZPORT instruction. When executing this instruction, the JTAG controller resets the core logic and asserts the EzPort chip select signal to force the processor into EzPort mode.

3.5.7.2 Flash Option Register (FOPT)

The FOPT[EZPORT_DIS] bit can be used to prevent entry into EzPort mode during reset. If the FOPT[EZPORT_DIS] bit is cleared, then the state of the chip select signal ($\overline{\text{EZP_CS}}$) is ignored and the MCU always boots in normal mode.

This option is useful for systems that use the $\overline{\text{EZP_CS}}$ /NMI signal configured for its NMI function. Disabling EzPort mode prevents possible unwanted entry into EzPort mode if the external circuit that drives the NMI signal asserts it during reset.

The FOPT register is loaded from the flash option byte. If the flash option byte is modified the new value takes effect for any subsequent resets, until the value is changed again.

3.6 Security

3.6.1 CRC Configuration

This section summarizes how the module has been configured in the chip. For a comprehensive description of the module itself, see the module's dedicated chapter.

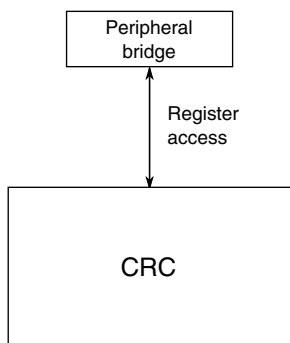

Figure 3-30. CRC configuration

Table 3-42. Reference links to related information

Topic	Related module	Reference
Full description	CRC	CRC
System memory map		System memory map
Power management		Power management

3.6.2 Drylce (tamper detect and secure storage) configuration

This section summarizes how the module has been configured in the chip. For a comprehensive description of the module itself, see the module’s dedicated chapter.

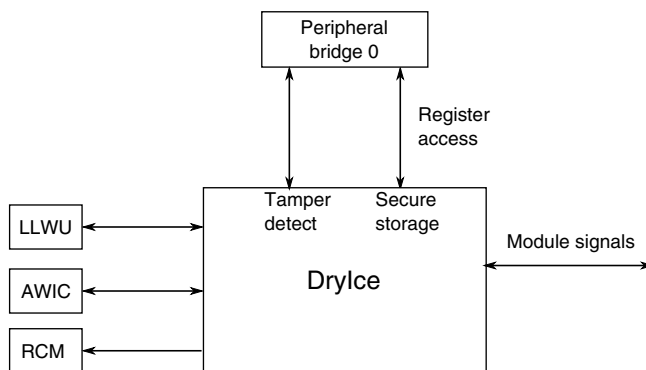

Figure 3-31. Drylce configuration

Table 3-43. Reference links to related information

Topic	Related module	Reference
Full description	Drylce	Drylce
System memory map		System memory map
Clocking		Clock Distribution
Power management		Power management

Table continues on the next page...

Table 3-43. Reference links to related information (continued)

Topic	Related module	Reference
System reset	Reset Control Module (RCM)	Tamper detect
AWIC		AWIC
LLWU		LLWU

3.7 Analog

3.7.1 16-bit SAR ADC with PGA Configuration

This section summarizes how the module has been configured in the chip. For a comprehensive description of the module itself, see the module's dedicated chapter.

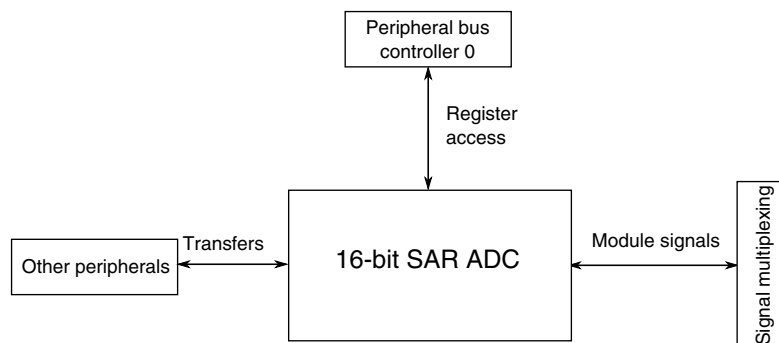
Figure 3-32. 16-bit SAR ADC with PGA configuration
Table 3-44. Reference links to related information

Topic	Related module	Reference
Full description	16-bit SAR ADC with PGA	16-bit SAR ADC with PGA
System memory map		System memory map
Clocking		Clock distribution
Power management		Power management
Signal multiplexing	Port control	Signal multiplexing

3.7.1.1 ADC instantiation information

This device contains two ADCs. Each ADC contains a PGA channel for a total of two separate PGAs.

3.7.1.1.1 Number of ADC channels

The number of ADC channels present on the device is determined by the pinout of the specific device package. For details regarding the number of ADC channel available on a particular package, refer to the signal multiplexing chapter of this MCU.

3.7.1.2 DMA Support on ADC

Applications may require continuous sampling of the ADC (4K samples/sec) that may have considerable load on the CPU. Though using PDB to trigger ADC may reduce some CPU load, The ADC supports DMA request functionality for higher performance when the ADC is sampled at a very high rate or cases were PDB is bypassed. The ADC can trigger the DMA (via DMA req) on conversion completion.

3.7.1.3 ADC0 Connections/Channel Assignment

NOTE

As indicated by the following sections, each ADCx_DPx input and certain ADCx_DMx inputs may operate as single-ended ADC channels in single-ended mode.

3.7.1.3.1 ADC0 Channel Assignment for 100-Pin Package

ADC Channel (SC1n[ADCH])	Channel	Input signal (SC1n[DIFF]= 1)	Input signal (SC1n[DIFF]= 0)
00000	DAD0	ADC0_DP0 and ADC0_DM0 ¹	ADC0_DP0 ²
00001	DAD1	ADC0_DP1 and ADC0_DM1	ADC0_DP1
00010	DAD2	PGA0_DP and PGA0_DM	PGA0_DP
00011	DAD3	ADC0_DP3 and ADC0_DM3 ³	ADC0_DP3 ⁴
00100 ⁵	AD4a	Reserved	
00101 ⁵	AD5a	Reserved	
00110 ⁵	AD6a	Reserved	
00111 ⁵	AD7a	Reserved	
00100 ⁵	AD4b	Reserved	ADC0_SE4b
00101 ⁵	AD5b	Reserved	ADC0_SE5b
00110 ⁵	AD6b	Reserved	ADC0_SE6b
00111 ⁵	AD7b	Reserved	ADC0_SE7b
01000	AD8	Reserved	ADC0_SE8 ⁶
01001	AD9	Reserved	ADC0_SE9 ⁷

Table continues on the next page...

ADC Channel (SC1n[ADCH])	Channel	Input signal (SC1n[DIFF]= 1)	Input signal (SC1n[DIFF]= 0)
01010	AD10	Reserved	Reserved
01011	AD11	Reserved	Reserved
01100	AD12	Reserved	ADC0_SE12
01101	AD13	Reserved	ADC0_SE13
01110	AD14	Reserved	ADC0_SE14
01111	AD15	Reserved	ADC0_SE15
10000	AD16	Reserved	
10001	AD17	Reserved	
10010	AD18	Reserved	
10011	AD19	Reserved	ADC0_DM0 ⁸
10100	AD20	Reserved	ADC0_DM1
10101	AD21	Reserved	
10110	AD22	Reserved	
10111	AD23	Reserved	12-bit DAC0 Output
11000	AD24	Reserved	Reserved
11001	AD25	Reserved	Reserved
11010	AD26	Temperature Sensor (Diff)	Temperature Sensor (S.E)
11011	AD27	Bandgap (Diff) ⁹	Bandgap (S.E) ⁹
11100	AD28	Reserved	Reserved
11101	AD29	-VREFH (Diff)	VREFH (S.E)
11110	AD30	Reserved	VREFL
11111	AD31	Module Disabled	Module Disabled

1. Interleaved with ADC1_DP3 and ADC1_DM3
2. Interleaved with ADC1_DP3
3. Interleaved with ADC1_DP0 and ADC1_DM0
4. Interleaved with ADC1_DP0
5. ADCx_CFG2[MUXSEL] bit selects between ADCx_SEn channels a and b. Refer to MUXSEL description in ADC chapter for details.
6. Interleaved with ADC1_SE8
7. Interleaved with ADC1_SE9
8. Interleaved with ADC1_DM3
9. This is the PMC bandgap 1V reference voltage not the VREF module 1.2 V reference voltage. Prior to reading from this ADC channel, ensure that you enable the bandgap buffer by setting the PMC_REGSC[BGBE] bit. Refer to the device data sheet for the bandgap voltage (V_{BG}) specification.

3.7.1.4 ADC1 Connections/Channel Assignment

NOTE

As indicated in the following tables, each ADCx_DPx input and certain ADCx_DMx inputs may operate as single-ended ADC channels in single-ended mode.

3.7.1.4.1 ADC1 Channel Assignment for 100-Pin Package

ADC Channel (SC1n[ADCH])	Channel	Input signal (SC1n[DIFF]= 1)	Input signal (SC1n[DIFF]= 0)
00000	DAD0	ADC1_DP0 and ADC1_DM0 ¹	ADC1_DP0 ²
00001	DAD1	ADC1_DP1 and ADC1_DM1	ADC1_DP1
00010	DAD2	PGA1_DP and PGA1_DM	PGA1_DP
00011	DAD3	ADC1_DP3 and ADC1_DM3 ³	ADC1_DP3 ⁴
00100 ⁵	AD4a	Reserved	ADC1_SE4a
00101 ⁵	AD5a	Reserved	ADC1_SE5a
00110 ⁵	AD6a	Reserved	ADC1_SE6a
00111 ⁵	AD7a	Reserved	ADC1_SE7a
00100 ⁵	AD4b	Reserved	ADC1_SE4b
00101 ⁵	AD5b	Reserved	ADC1_SE5b
00110 ⁵	AD6b	Reserved	ADC1_SE6b
00111 ⁵	AD7b	Reserved	ADC1_SE7b
01000	AD8	Reserved	ADC1_SE8 ⁶
01001	AD9	Reserved	ADC1_SE9 ⁷
01010	AD10	Reserved	Reserved
01011	AD11	Reserved	Reserved
01100	AD12	Reserved	Reserved
01101	AD13	Reserved	
01110	AD14	Reserved	ADC1_SE14
01111	AD15	Reserved	ADC1_SE15
10000	AD16	Reserved	
10001	AD17	Reserved	
10010	AD18	Reserved	VREF Output
10011	AD19	Reserved	ADC1_DM0 ⁸
10100	AD20	Reserved	ADC1_DM1
10101	AD21	Reserved	Reserved
10110	AD22	Reserved	
10111	AD23	Reserved	
11000	AD24	Reserved	Reserved
11001	AD25	Reserved	Reserved
11010	AD26	Temperature Sensor (Diff)	Temperature Sensor (S.E)
11011	AD27	Bandgap (Diff) ⁹	Bandgap (S.E) ⁹
11100	AD28	Reserved	Reserved
11101	AD29	-VREFH (Diff)	VREFH (S.E)
11110	AD30	Reserved	VREFL
11111	AD31	Module Disabled	Module Disabled

1. Interleaved with ADC0_DP3 and ADC0_DM3
2. Interleaved with ADC0_DP3
3. Interleaved with ADC0_DP0 and ADC0_DM0
4. Interleaved with ADC0_DP0

5. ADCx_CFG2[MUXSEL] bit selects between ADCx_SEn channels a and b. Refer to MUXSEL description in ADC chapter for details.
6. Interleaved with ADC0_SE8
7. Interleaved with ADC0_SE9
8. Interleaved with ADC0_DM3
9. This is the PMC bandgap 1V reference voltage not the VREF module 1.2 V reference voltage. Prior to reading from this ADC channel, ensure that you enable the bandgap buffer by setting the PMC_REGSC[BGBE] bit. Refer to the device data sheet for the bandgap voltage (V_{BG}) specification.

3.7.1.5 ADC Channels MUX Selection

The following figure shows the assignment of ADCx_SEn channels a and b through a MUX selection to ADC. To select between alternate set of channels, refer to ADCx_CFG2[MUXSEL] bit settings for more details.

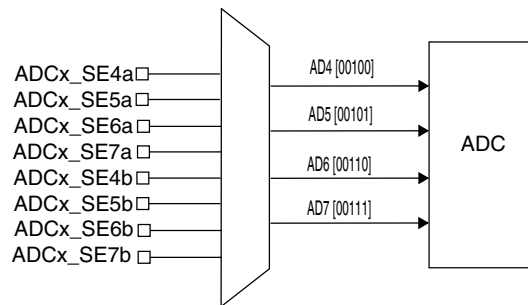

Figure 3-33. ADCx_SEn channels a and b selection

3.7.1.6 ADC Hardware Interleaved Channels

The AD8 and AD9 channels on ADCx are interleaved in hardware using the following configuration.

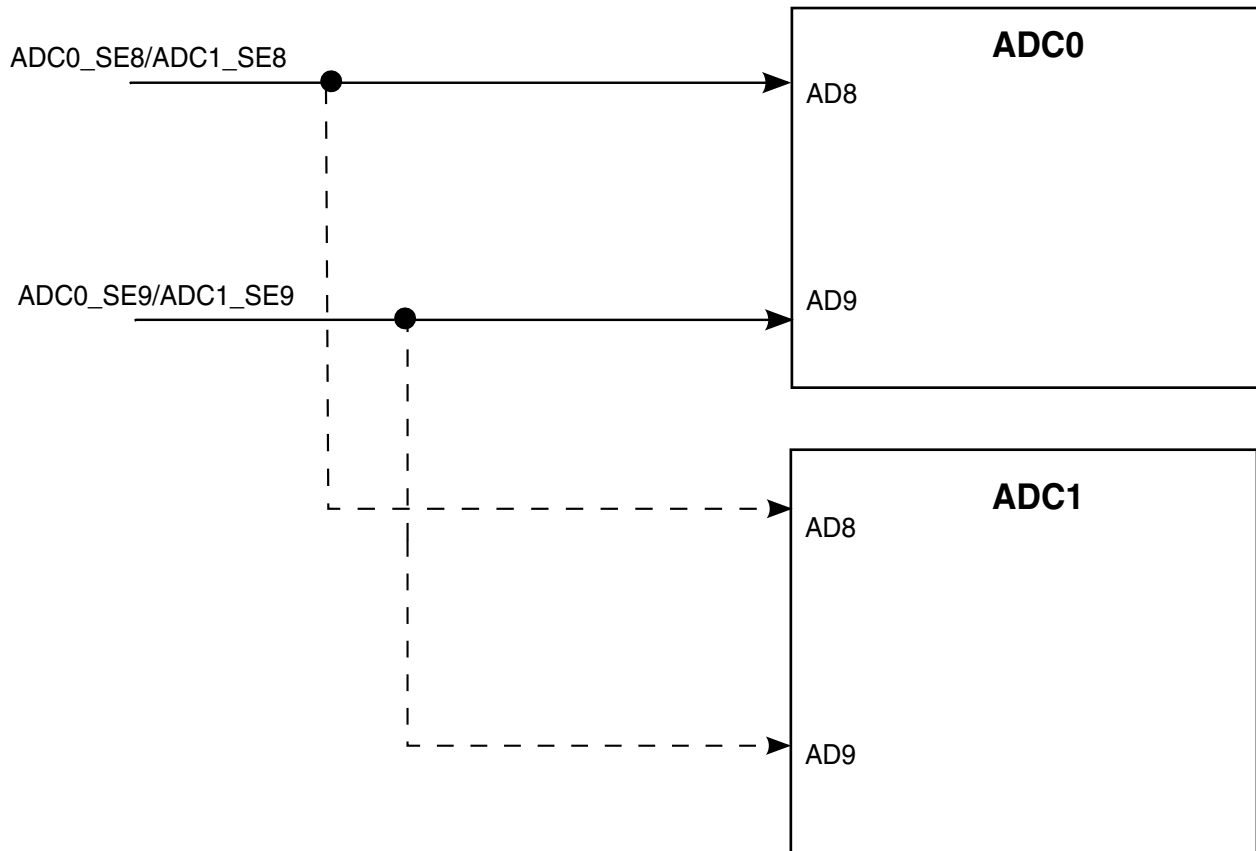

Figure 3-34. ADC hardware interleaved channels integration

3.7.1.7 ADC and PGA Reference Options

The ADC supports the following references:

- VREFH/VREFL - connected as the primary reference option
- 1.2 V VREF_OUT - connected as the V_{ALT} reference option

ADC_x_SC2[REFSEL] bit selects the voltage reference sources for ADC. Refer to REFSEL description in ADC chapter for more details.

The only reference option for the PGA is the 1.2 V VREF_OUT source. The VREF_OUT signal can either be driven by an external voltage source via the VREF_OUT pin or from the output of the VREF module. Ensure that the VREF module is disabled when an external voltage source is used instead. For PGA maximum differential input signal swing range, refer to the device data sheet for 16-bit ADC with PGA characteristics.

3.7.1.8 ADC triggers

The ADC supports both software and hardware triggers. The primary hardware mechanism for triggering the ADC is the PDB. The PDB itself can be triggered by other peripherals. For example: RTC (Alarm, Seconds) signal is connected to the PDB. The PDB trigger can receive the RTC (alarm/seconds) trigger input forcing ADC conversions in run mode (where PDB is enabled). On the other hand, the ADC can conduct conversions in low power modes, not triggered by PDB. This allows the ADC to do conversions in low power mode and store the output in the result register. The ADC generates interrupt when the data is ready in the result register that wakes the system from low power mode. The PDB can also be bypassed by using the ADCxTRGSEL bits in the SOPT7 register.

For operation of triggers in different modes, refer to Power Management chapter.

3.7.1.9 Alternate clock

For this device, the alternate clock is connected to OSCERCLK.

NOTE

This clock option is only usable when OSCERCLK is in the MHz range. A system with OSCERCLK in the kHz range has the optional clock source below minimum ADC clock operating frequency.

3.7.1.10 ADC low-power modes

This table shows the ADC low-power modes and the corresponding chip low-power modes.

Table 3-45. ADC low-power modes

Module mode	Chip mode
Wait	Wait, VLPW
Normal Stop	Stop, VLPS
Low Power Stop	LLS, VLLS3, VLLS2, VLLS1

3.7.1.11 PGA Integration

- No additional external pins are required for the PGA as it is part of the ADC and is selected as a separate channel

- Each PGA connects to the differential ADC channels
- The PGA outputs differential pairs that are connected to ADC differential input
- When the PGA is used, differential input from the pins is connected to differential input channel 2 on ADCx

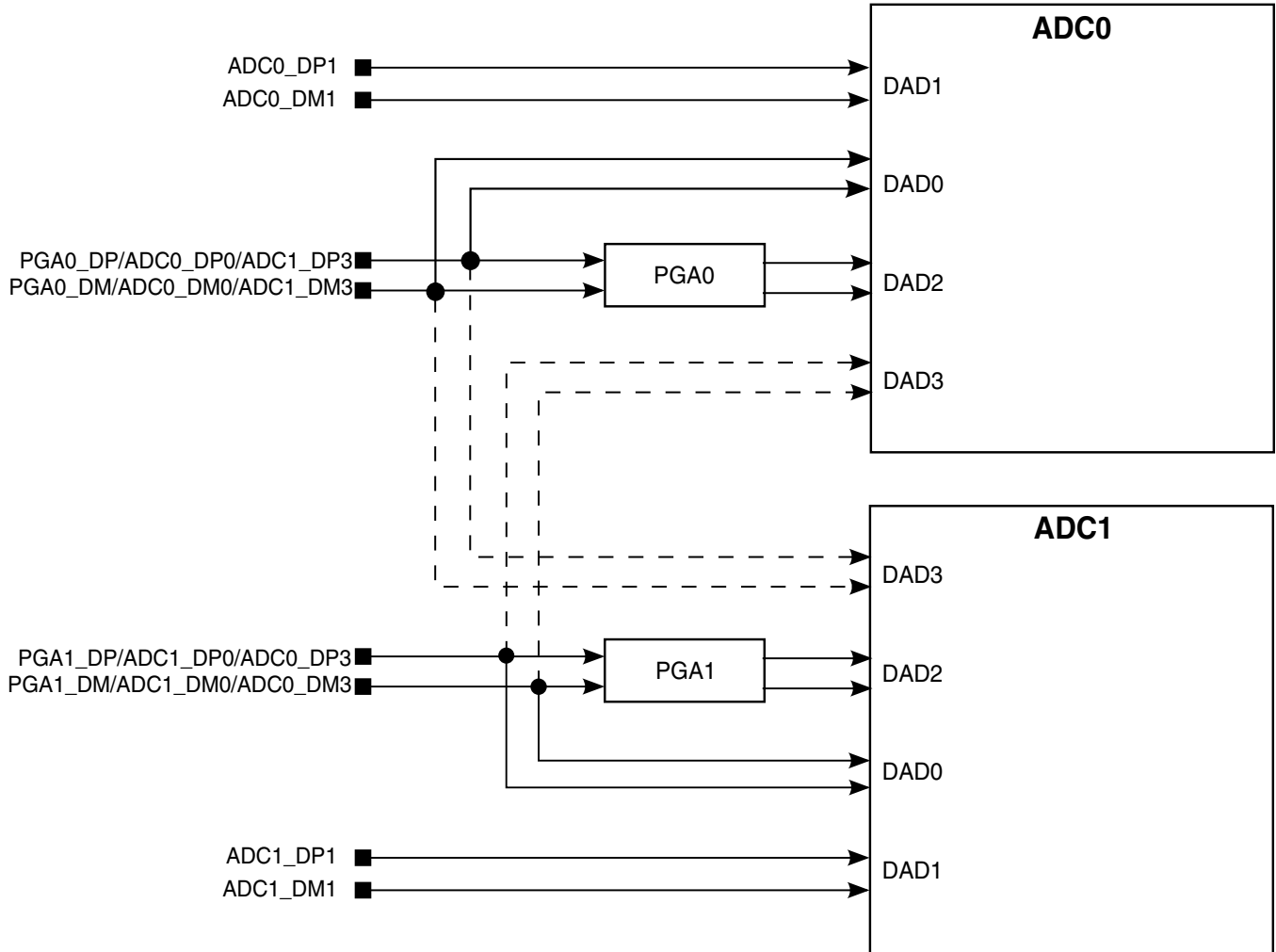
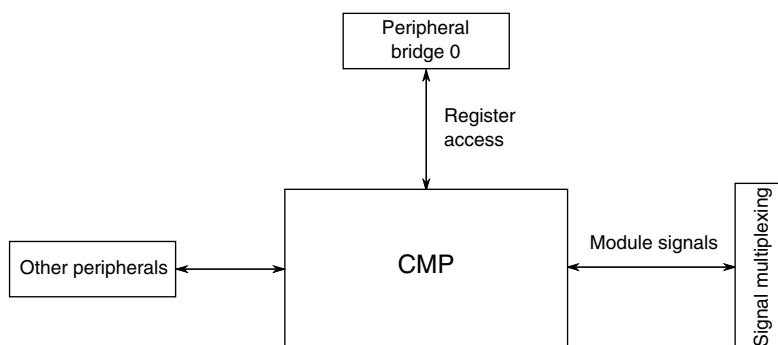

Figure 3-35. PGA Integration

3.7.2 CMP Configuration

This section summarizes how the module has been configured in the chip. For a comprehensive description of the module itself, see the module’s dedicated chapter.

Figure 3-36. CMP configuration
Table 3-46. Reference links to related information

Topic	Related module	Reference
Full description	Comparator (CMP)	Comparator
System memory map		System memory map
Clocking		Clock distribution
Power management		Power management
Signal multiplexing	Port control	Signal multiplexing

3.7.2.1 CMP input connections

The following table shows the fixed internal connections to the CMP.

CMP Inputs	CMP0	CMP1	CMP2
IN0	CMP0_IN0	CMP1_IN0	CMP2_IN0
IN1	CMP0_IN1	CMP1_IN1	CMP2_IN1
IN2	CMP0_IN2	—	—
IN3	CMP0_IN3	12b DAC0 reference/ CMP1_IN3	CMP2_IN3
IN4	CMP0_IN4	—	—
IN5	VREF output/CMP0_IN5	VREF output/CMP1_IN5	—CMP2_IN5
IN6	Bandgap	Bandgap	Bandgap
IN7	6b DAC0 reference	6b DAC1 reference	—

3.7.2.2 CMP external references

The 6-bit DAC sub-block supports selection of two references. For this device, the references are connected as follows:

- VREF_OUT - V_{in1} input
- VDD - V_{in2} input

3.7.2.3 External window/sample input

PDB pulse-out controls the CMP Sample/Window timing.

3.7.3 12-bit DAC Configuration

This section summarizes how the module has been configured in the chip. For a comprehensive description of the module itself, see the module’s dedicated chapter.

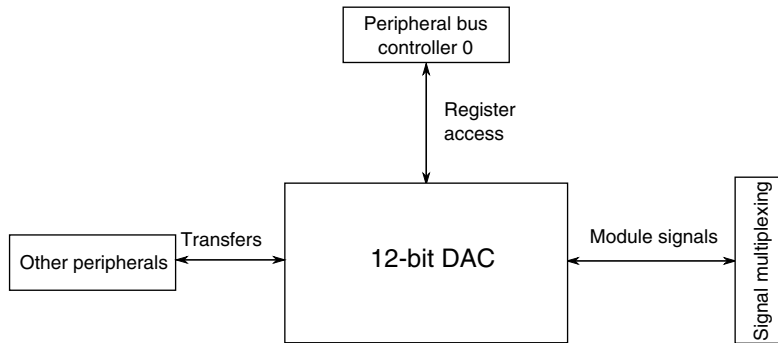

Figure 3-37. 12-bit DAC configuration

Table 3-47. Reference links to related information

Topic	Related module	Reference
Full description	12-bit DAC	12-bit DAC
System memory map		System memory map
Clocking		Clock distribution
Power management		Power management
Signal multiplexing	Port control	Signal multiplexing

3.7.3.1 12-bit DAC Overview

This device contains one 12-bit digital-to-analog converter (DAC) with programmable reference generator output. The DAC includes a FIFO for DMA support.

3.7.3.2 12-bit DAC Output

The output of the DAC can be placed on an external pin or set as one of the inputs to the analog comparator or ADC.

3.7.3.3 12-bit DAC Reference

For this device VREF_OUT and VDDA are selectable as the DAC reference. VREF_OUT is connected to the DACREF_1 input and VDDA is connected to the DACREF_2 input. Use DACx_C0[DACRFS] control bit to select between these two options.

Be aware that if the DAC and ADC use the VREF_OUT reference simultaneously, some degradation of ADC accuracy is to be expected due to DAC switching.

3.7.4 VREF Configuration

This section summarizes how the module has been configured in the chip. For a comprehensive description of the module itself, see the module’s dedicated chapter.

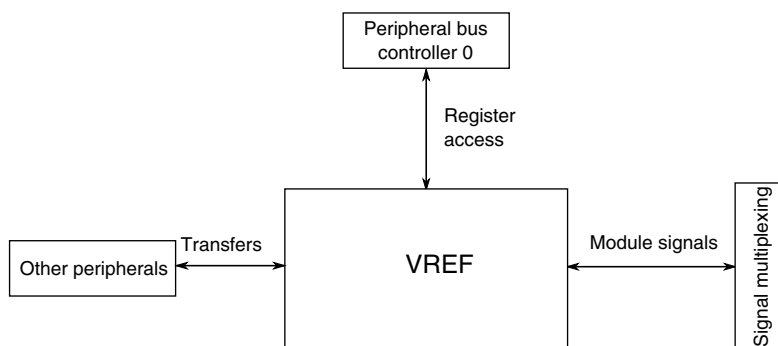

Figure 3-38. VREF configuration

Table 3-48. Reference links to related information

Topic	Related module	Reference
Full description	VREF	VREF
System memory map		System memory map
Clocking		Clock distribution
Power management		Power management
Signal multiplexing	Port control	Signal multiplexing

3.7.4.1 VREF Overview

This device includes a voltage reference (VREF) to supply an accurate 1.2 V voltage output.

The voltage reference can provide a reference voltage to external peripherals or a reference to analog peripherals, such as the ADC, DAC, or CMP.

NOTE

For either an internal or external reference if the VREF_OUT functionality is being used, VREF_OUT signal must be connected to an output load capacitor. Refer the device data sheet for more details.

3.8 Timers

3.8.1 PDB Configuration

This section summarizes how the module has been configured in the chip. For a comprehensive description of the module itself, see the module’s dedicated chapter.

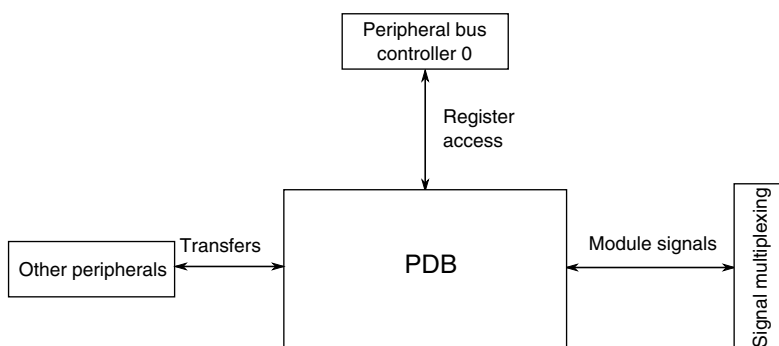

Figure 3-39. PDB configuration

Table 3-49. Reference links to related information

Topic	Related module	Reference
Full description	PDB	PDB
System memory map		System memory map
Clocking		Clock distribution
Power management		Power management
Signal multiplexing	Port control	Signal multiplexing

3.8.1.1 PDB Instantiation

3.8.1.1.1 PDB Output Triggers

Table 3-50. PDB output triggers

Number of PDB channels for ADC trigger	2
Number of pre-triggers per PDB channel	2
Number of DAC triggers	1
Number of PulseOut	1

3.8.1.1.2 PDB Input Trigger Connections

Table 3-51. PDB Input Trigger Options

PDB Trigger	PDB Input
0000	External Trigger
0001	CMP 0
0010	CMP 1
0011	CMP 2
0100	PIT Ch 0 Output
0101	PIT Ch 1 Output
0110	PIT Ch 2 Output
0111	PIT Ch 3 Output
1000	FTM0 Init and Ext Trigger Outputs
1001	FTM1 Init and Ext Trigger Outputs
1010	FTM2 Init and Ext Trigger Outputs
1011	Reserved
1100	RTC Alarm
1101	RTC Seconds
1110	LPTMR Output
1111	Software Trigger

3.8.1.2 PDB Module Interconnections

PDB trigger outputs	Connection
Channel 0 triggers	ADC0 trigger
Channel 1 triggers	ADC1 trigger and synchronous input 1 of FTM0
DAC triggers	DAC0 trigger
Pulse-out	Pulse-out connected to each CMP module's sample/window input to control sample operation

3.8.1.3 Back-to-back acknowledgement connections

In this MCU, PDB back-to-back operation acknowledgement connections are implemented as follows:

- PDB channel 0 pre-trigger 0 acknowledgement input: ADC1SC1B_COCO
- PDB channel 0 pre-trigger 1 acknowledgement input: ADC0SC1A_COCO
- PDB channel 1 pre-trigger 0 acknowledgement input: ADC0SC1B_COCO
- PDB channel 1 pre-trigger 1 acknowledgement input: ADC1SC1A_COCO

So, the back-to-back chain is connected as a ring:

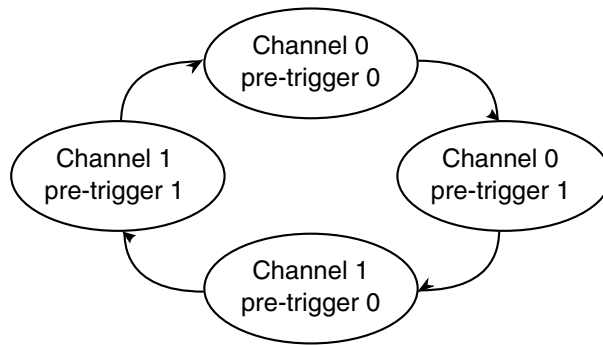

Figure 3-40. PDB back-to-back chain

The application code can set the PDBx_CHnC1[BB] bits to configure the PDB pre-triggers as a single chain or several chains.

3.8.1.4 PDB Interval Trigger Connections to DAC

In this MCU, PDB interval trigger connections to DAC are implemented as follows.

- PDB interval trigger 0 connects to DAC0 hardware trigger input.

3.8.1.5 DAC External Trigger Input Connections

In this MCU, two DAC external trigger inputs are implemented.

- DAC external trigger input 0: ADC0SC1A_COCO
- DAC external trigger input 1: ADC1SC1A_COCO

NOTE

Application code can set the PDBx_DACINTCn[EXT] bit to allow DAC external trigger input when the corresponding ADC Conversion complete flag, ADCx_SC1n[COCO], is set.

3.8.1.6 Pulse-Out Connection

The Pulse-Out of PDB is connected to all the CMP blocks and used as the sample window.

3.8.1.7 Pulse-Out Enable Register Implementation

The following table shows the comparison of pulse-out enable register at the module and chip level.

Table 3-52. PDB pulse-out enable register

Register	Module implementation	Chip implementation
POnEN	7:0 - POEN 31:8 - Reserved	0 - POEN 31:1 - Reserved

3.8.2 FlexTimer Configuration

This section summarizes how the module has been configured in the chip. For a comprehensive description of the module itself, see the module's dedicated chapter.

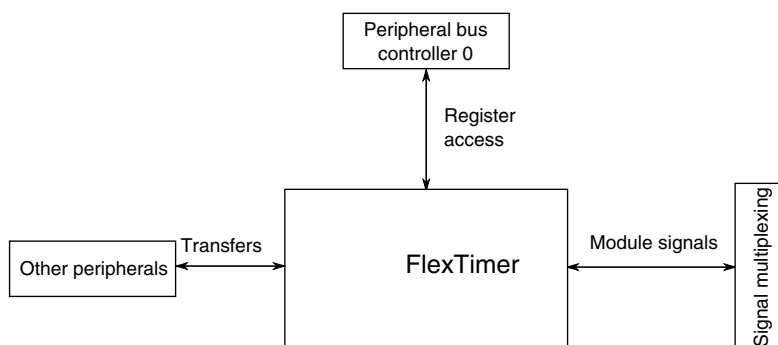

Figure 3-41. FlexTimer configuration

Table 3-53. Reference links to related information

Topic	Related module	Reference
Full description	FlexTimer	FlexTimer
System memory map		System memory map
Clocking		Clock distribution
Power management		Power management
Signal multiplexing	Port control	Signal multiplexing

3.8.2.1 Instantiation Information

This device contains three FlexTimer modules.

The following table shows how these modules are configured.

Table 3-54. FTM Instantiations

FTM instance	Number of channels	Features/usage
FTM0	8	3-phase motor + 2 general purpose or stepper motor
FTM1	2	Quadrature decoder or general purpose
FTM2	2	Quadrature decoder or general purpose

Compared with the FTM0 configuration, the FTM1 and FTM2 configuration adds the Quadrature decoder feature and reduces the number of channels.

3.8.2.2 External Clock Options

By default each FTM is clocked by the internal bus clock (the FTM refers to it as system clock). Each module contains a register setting that allows the module to be clocked from an external clock instead. There are two external FTM_CLKINx pins that can be selected by any FTM module via the SOPT4 register in the SIM module.

3.8.2.3 Fixed frequency clock

The fixed frequency clock for each FTM is MCGFFCLK.

3.8.2.4 FTM Interrupts

The FlexTimer has multiple sources of interrupt. However, these sources are OR'd together to generate a single interrupt request to the interrupt controller. When an FTM interrupt occurs, read the FTM status registers (FMS, SC, and STATUS) to determine the exact interrupt source.

3.8.2.5 FTM Fault Detection Inputs

The following fault detection input options for the FTM modules are selected via the SOPT4 register in the SIM module. The external pin option is selected by default.

- FTM0 FAULT0 = FTM0_FLT0 pin or CMP0 output
- FTM0 FAULT1 = FTM0_FLT1 pin or CMP1 output
- FTM0 FAULT2 = FTM0_FLT2 pin or CMP2 output
- FTM0 FAULT3 = FTM0_FLT3 pin

- FTM1 FAULT0 = FTM1_FLT0 pin or CMP0 output
- FTM1 FAULT1 = CMP1 output
- FTM1 FAULT2 = CMP2 output

- FTM2 FAULT0 = FTM2_FLT0 pin or CMP0 output
- FTM2 FAULT1 = CMP1 output
- FTM2 FAULT2 = CMP2 output

3.8.2.6 FTM Hardware Triggers

The FTM synchronization hardware triggers are connected in the chip as follows:

- FTM0 hardware trigger 0 = CMP0 Output
- FTM0 hardware trigger 1 = PDB channel 1 Trigger Output
- FTM0 hardware trigger 2 = FTM0_FLT0 pin

- FTM1 hardware trigger 0 = CMP0 Output
- FTM1 hardware trigger 1 = CMP1 Output
- FTM1 hardware trigger 2 = FTM1_FLT0 pin

- FTM2 hardware trigger 0 = CMP0 Output
- FTM2 hardware trigger 1 = CMP2 Output
- FTM2 hardware trigger 2 = FTM2_FLT0 pin

3.8.2.7 Input capture options for FTM module instances

The following channel 0 input capture source options are selected via the SOPT4 register in the SIM module. The external pin option is selected by default.

- FTM1 channel 0 input capture = FTM1_CH0 pin or CMP0 output or CMP1 output
- FTM2 channel 0 input capture = FTM2_CH0 pin or CMP0 output or CMP1 output

3.8.2.8 FTM output triggers for other modules

FTM output triggers can be selected as input triggers for the PDB and ADC modules. See [PDB Instantiation](#) and [ADC triggers](#).

3.8.2.9 FTM Global Time Base

This chip provides the optional FTM global time base feature (see [Global Time Base \(GTB\)](#)).

FTM0 provides the only source for the FTM global time base. The other FTM modules can share the time base as shown in the following figure:

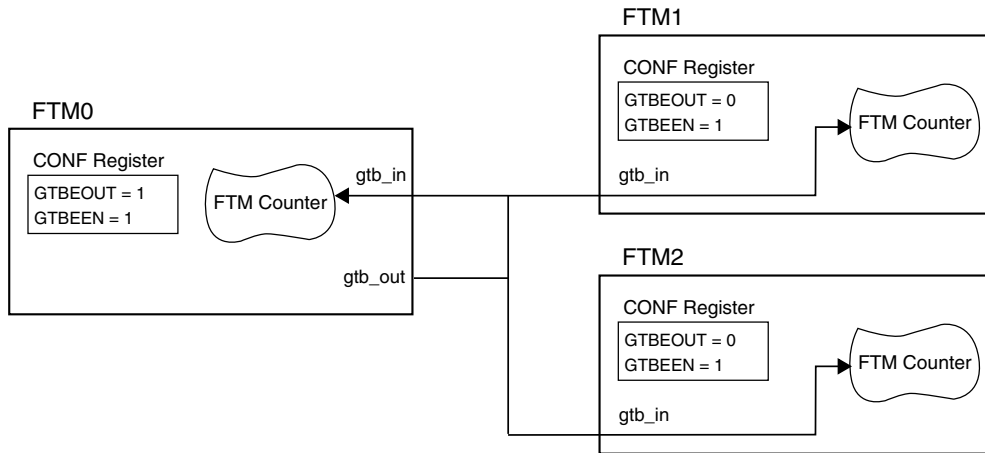

Figure 3-42. FTM Global Time Base Configuration

3.8.2.10 FTM BDM and debug halt mode

In the FTM chapter, references to the chip being in "BDM" are the same as the chip being in "debug halt mode".

3.8.3 PIT Configuration

This section summarizes how the module has been configured in the chip. For a comprehensive description of the module itself, see the module's dedicated chapter.

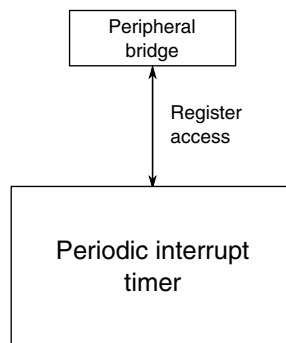

Figure 3-43. PIT configuration

Table 3-55. Reference links to related information

Topic	Related module	Reference
Full description	PIT	PIT
System memory map		System memory map
Clocking		Clock Distribution
Power management		Power management

3.8.3.1 PIT/DMA Periodic Trigger Assignments

The PIT generates periodic trigger events to the DMA Mux as shown in the table below.

Table 3-56. PIT channel assignments for periodic DMA triggering

DMA Channel Number	PIT Channel
DMA Channel 0	PIT Channel 0
DMA Channel 1	PIT Channel 1
DMA Channel 2	PIT Channel 2
DMA Channel 3	PIT Channel 3

3.8.3.2 PIT/ADC Triggers

PIT triggers are selected as ADCx trigger sources using the SOPT7[ADCxTRGSEL] bits in the SIM module. For more details, refer to SIM chapter.

3.8.4 Low-power timer configuration

This section summarizes how the module has been configured in the chip. For a comprehensive description of the module itself, see the module's dedicated chapter.

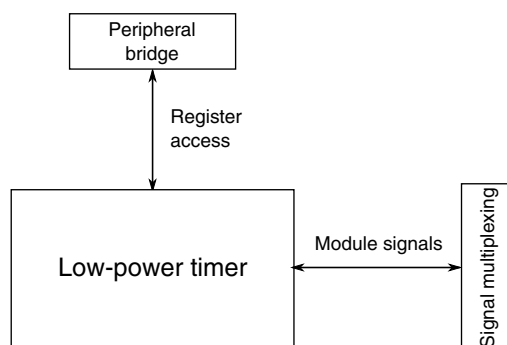

Figure 3-44. LPT configuration

Table 3-57. Reference links to related information

Topic	Related module	Reference
Full description	Low-power timer	Low-power timer
System memory map		System memory map
Clocking		Clock Distribution

Table continues on the next page...

Table 3-57. Reference links to related information (continued)

Topic	Related module	Reference
Power management		Power management
Signal Multiplexing	Port control	Signal Multiplexing

3.8.4.1 LPTMR prescaler/glitch filter clocking options

The prescaler and glitch filter of the LPTMR module can be clocked from one of four sources determined by the LPTMR0_PSR[PCS] bitfield. The following table shows the chip-specific clock assignments for this bitfield.

NOTE

The chosen clock must remain enabled if the LPTMR is to continue operating in all required low-power modes.

LPTMR0_PSR[PCS]	Prescaler/glitch filter clock number	Chip clock
00	0	MCGIRCLK — internal reference clock (not available in VLPS/LLS/VLLS modes)
01	1	LPO — 1 kHz clock
10	2	ERCLK32K — secondary external reference clock
11	3	OSCERCLK — external reference clock

See [Clock Distribution](#) for more details on these clocks.

3.8.4.2 LPTMR pulse counter input options

The LPTMR_CSR[TPS] bitfield configures the input source used in pulse counter mode. The following table shows the chip-specific input assignments for this bitfield.

LPTMR_CSR[TPS]	Pulse counter input number	Chip input
00	0	CMP0 output
01	1	LPTMR_ALT1 pin
10	2	LPTMR_ALT2 pin
11	3	Reserved

3.8.5 CMT Configuration

This section summarizes how the module has been configured in the chip. For a comprehensive description of the module itself, see the module's dedicated chapter.

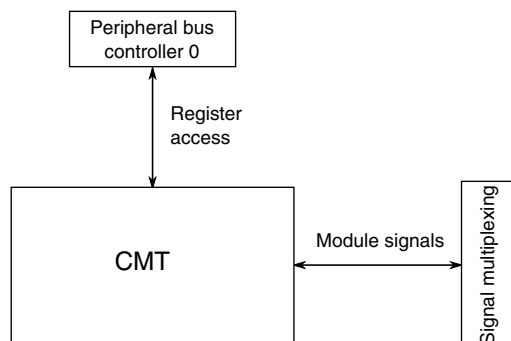

Figure 3-45. CMT configuration

Table 3-58. Reference links to related information

Topic	Related module	Reference
Full description	Carrier modulator transmitter (CMT)	CMT
System memory map		System memory map
Clocking		Clock distribution
Power management		Power management
Signal multiplexing	Port control	Signal multiplexing

3.8.5.1 Instantiation Information

This device contains one CMT module.

3.8.5.2 IRO Drive Strength

The IRO pad requires higher current drive than can be obtained from a single pad. For this device, the pin associated with the CMT_IRO signal is doubled bonded to two pads.

The SOPT2[CMTUARTPAD] field in SIM module can be used to configure the pin associated with the CMT_IRO signal as a higher current output port pin.

3.8.6 RTC configuration

This section summarizes how the module has been configured in the chip. For a comprehensive description of the module itself, see the module's dedicated chapter.

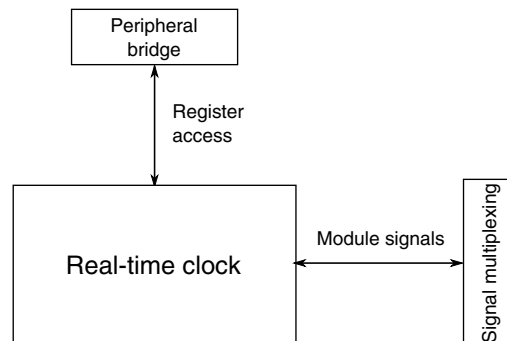

Figure 3-46. RTC configuration

Table 3-59. Reference links to related information

Topic	Related module	Reference
Full description	RTC	RTC
System memory map		System memory map
Clocking		Clock Distribution
Power management		Power management

3.8.6.1 RTC_CLKOUT signal

When the RTC is enabled and the port control module selects the RTC_CLKOUT function, the RTC_CLKOUT signal is fixed to a 1 Hz output.

3.8.6.2 RTC_WAKEUP signal

The RTC_WAKEUP pin is not supported on this device.

3.8.6.3 RTC seconds interrupt

The RTC seconds interrupt is not supported on this device.

3.9 Communication interfaces

3.9.1 Universal Serial Bus (USB) Subsystem

The USB subsystem includes these components:

- Dual-role USB OTG-capable (On-The-Go) controller that supports a full-speed (FS) device or FS/LS host. The module complies with the USB 2.0 specification.
- USB transceiver that includes internal 15 kΩ pulldowns on the D+ and D- lines for host mode functionality.
- A 3.3 V regulator.
- USB device charger detection module.
- VBUS detect signal: To detect a valid VBUS in device mode, use a GPIO signal that can wake the chip in all power modes.

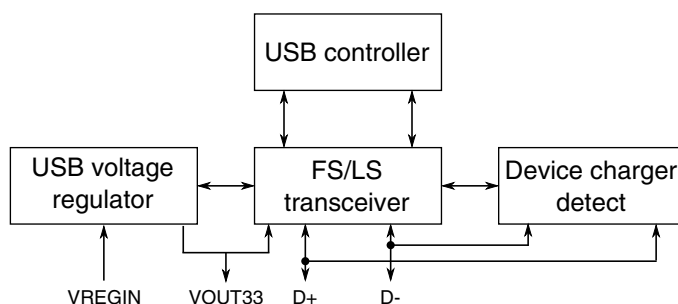

Figure 3-47. USB Subsystem Overview

3.9.1.1 USB Wakeup

When the USB detects that there is no activity on the USB bus for more than 3 ms, the INT_STAT[SLEEP] bit is set. This bit can cause an interrupt and software decides the appropriate action.

Waking from a low power mode (except in LLS/VLLS mode where USB is not powered) occurs through an asynchronous interrupt triggered by activity on the USB bus. Setting the USBTRC0[USBRESMEN] bit enables this function.

3.9.1.2 USB Power Distribution

This chip includes an internal 5 V to 3.3 V USB regulator that powers the USB transceiver or the MCU (depending on the application).

3.9.1.2.1 AA/AAA cells power supply

The chip can be powered by two AA/AAA cells. In this case, the MCU is powered through VDD which is within the 1.8 to 3.0 V range. After USB cable insertion is detected, the USB regulator is enabled to power the USB transceiver.

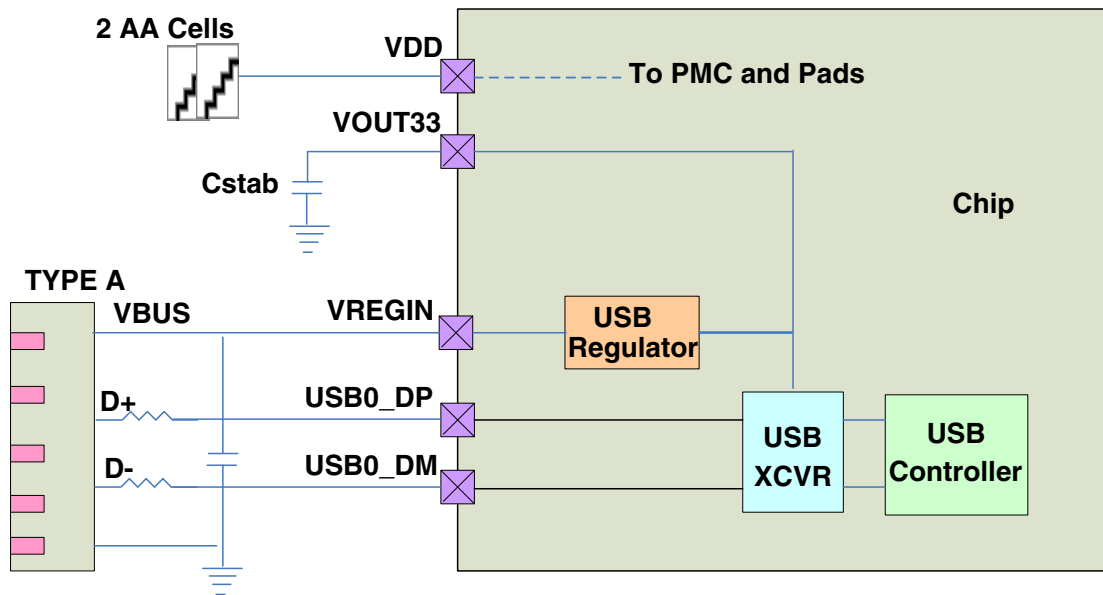

Figure 3-48. USB regulator AA cell usecase

3.9.1.2.2 Li-Ion battery power supply

The chip can also be powered by a single Li-ion battery. In this case, VOUT33 is connected to VDD. The USB regulator must be enabled by default to power the MCU. When connected to a USB host, the input source of this regulator is switched to the USB bus supply from the Li-ion battery. To charge the battery, the MCU can configure the battery charger according to the charger detection information.

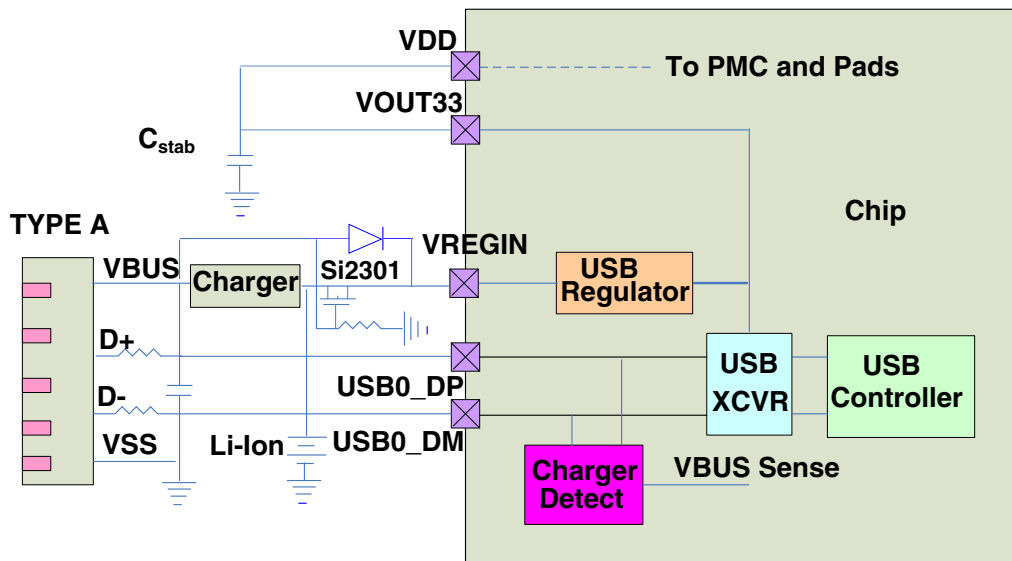

Figure 3-49. USB regulator Li-ion usecase

3.9.1.2.3 USB bus power supply

The chip can also be powered by the USB bus directly. In this case, VOUT33 is connected to VDD. The USB regulator must be enabled by default to power the MCU, then to power USB transceiver or external sensor.

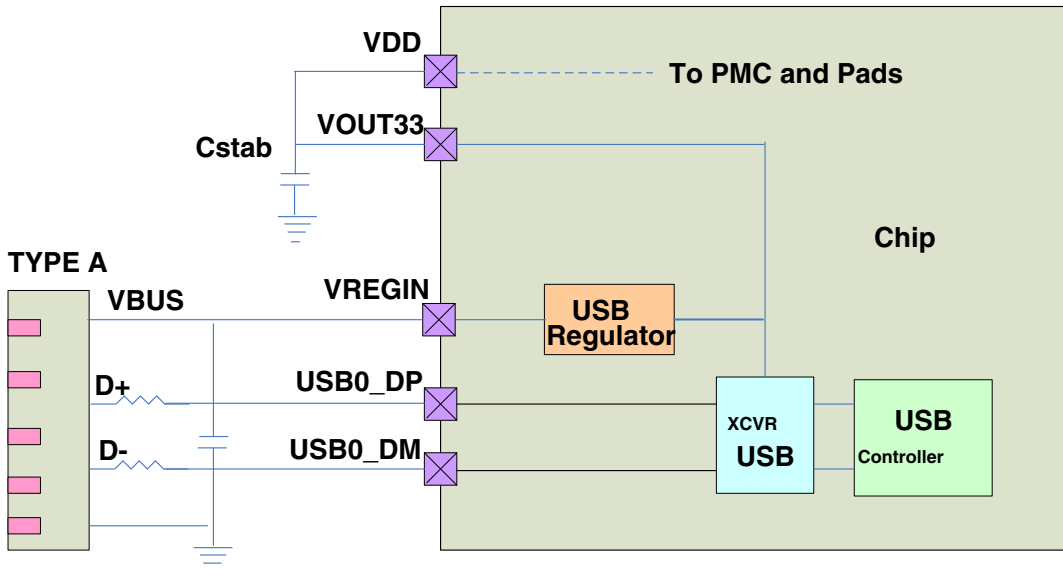

Figure 3-50. USB regulator bus supply

3.9.1.3 USB power management

The regulator should be put into STANDBY mode whenever the chip is in Stop mode. This can be done by setting the SIM_SOPT1[USBSTBY] bit.

3.9.1.4 USB controller configuration

This section summarizes how the module has been configured in the chip. For a comprehensive description of the module itself, see the module’s dedicated chapter.

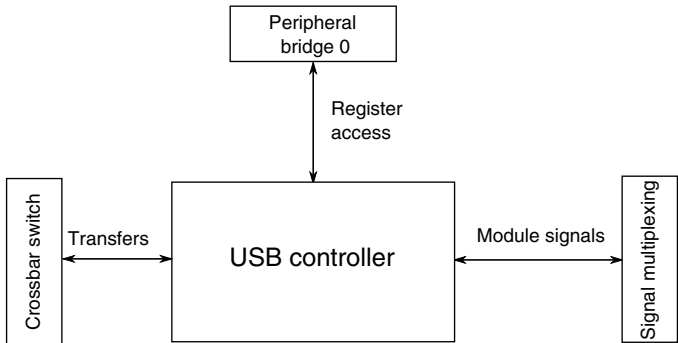

Figure 3-51. USB controller configuration

Table 3-60. Reference links to related information

Topic	Related module	Reference
Full description	USB controller	USB controller
System memory map		System memory map
Clocking		Clock Distribution
Transfers	Crossbar switch	Crossbar switch
Signal Multiplexing	Port control	Signal Multiplexing

NOTE

When USB is not used in the application, it is recommended that the USB regulator VREGIN and VOUT33 pins remain floating.

3.9.1.5 USB DCD Configuration

This section summarizes how the module has been configured in the chip. For a comprehensive description of the module itself, see the module’s dedicated chapter.

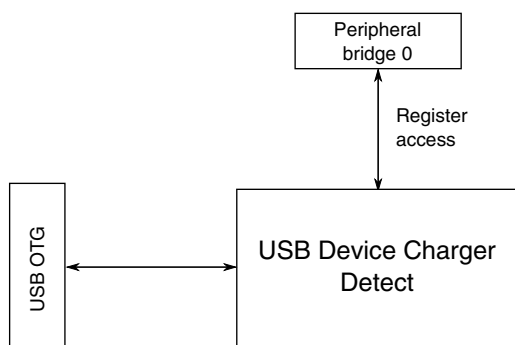

Figure 3-52. USB DCD configuration

Table 3-61. Reference links to related information

Topic	Related module	Reference
Full description	USB DCD	USB DCD
System memory map		System memory map
Clocking		Clock Distribution
	USB controller	USB controller

3.9.1.6 USB Voltage Regulator Configuration

This section summarizes how the module has been configured in the chip. For a comprehensive description of the module itself, see the module’s dedicated chapter.

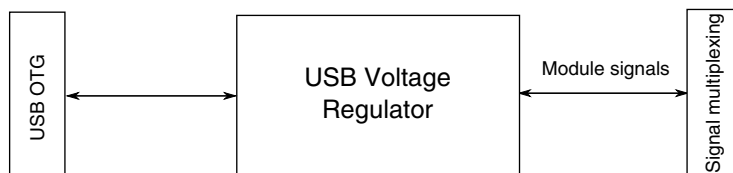

Figure 3-53. USB Voltage Regulator configuration

Table 3-62. Reference links to related information

Topic	Related module	Reference
Full description	USB Voltage Regulator	USB Voltage Regulator
System memory map		System memory map
Clocking		Clock Distribution
	USB controller	USB controller
Signal Multiplexing	Port control	Signal Multiplexing

NOTE

When USB is not used in the application, it is recommended that the USB regulator VREGIN and VOUT33 pins remain floating.

3.9.2 CAN Configuration

This section summarizes how the module has been configured in the chip. For a comprehensive description of the module itself, see the module's dedicated chapter.

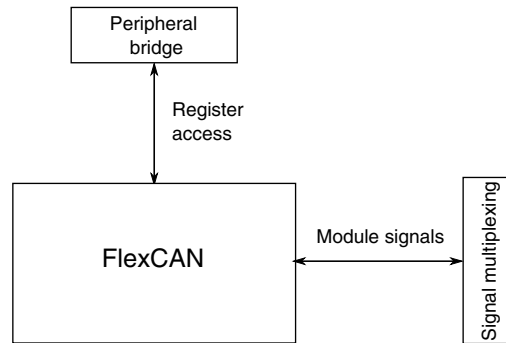

Figure 3-54. CAN configuration

Table 3-63. Reference links to related information

Topic	Related module	Reference
Full description	CAN	CAN
System memory map		System memory map
Clocking		Clock Distribution
Power management		Power management
Signal Multiplexing	Port control	Signal Multiplexing

3.9.2.1 Number of FlexCAN modules

This device contains 2 identical FlexCAN modules.

3.9.2.2 Reset value of MDIS bit

The CAN_MCR[MDIS] bit is set after reset. Therefore, FlexCAN module is disabled following a reset.

3.9.2.3 Number of message buffers

Each FlexCAN module contains 16 message buffers. Each message buffer is 16 bytes.

3.9.2.4 FlexCAN Clocking

3.9.2.4.1 Clocking Options

The FlexCAN module has a register bit CANCTRL[CLK_SRC] that selects between clocking the FlexCAN from the internal bus clock or the input clock (EXTAL).

3.9.2.4.2 Clock Gating

The clock to each CAN module can be gated on and off using the SCGC_n[CAN_x] bits. These bits are cleared after any reset, which disables the clock to the corresponding module. The appropriate clock enable bit should be set by software at the beginning of the FlexCAN initialization routine to enable the module clock before attempting to initialize any of the FlexCAN registers.

3.9.2.5 FlexCAN Interrupts

The FlexCAN has multiple sources of interrupt requests. However, some of these sources are OR'd together to generate a single interrupt request. See below for the mapping of the individual interrupt sources to the interrupt request:

Request	Sources
Message buffer	Message buffers 0-15
Bus off	Bus off
Error	<ul style="list-style-type: none"> • Bit1 error • Bit0 error • Acknowledge error • Cyclic redundancy check (CRC) error • Form error • Stuffing error • Transmit error warning • Receive error warning
Transmit Warning	Transmit Warning
Receive Warning	Receive Warning
Wake-up	Wake-up

3.9.2.6 FlexCAN Operation in Low Power Modes

The FlexCAN module is operational in VLPR and VLPW modes. With the 2 MHz bus clock, the fastest supported FlexCAN transfer rate is 256 kbps. The bit timing parameters in the module must be adjusted for the new frequency, but full functionality is possible.

The FlexCAN module can be configured to generate a wakeup interrupt in STOP and VLPS modes. When the FlexCAN is configured to generate a wakeup, a recessive to dominant transition on the CAN bus generates an interrupt.

3.9.2.7 FlexCAN Doze Mode

The Doze mode for the FlexCAN module is the same as the Wait and VLPW modes for the chip.

3.9.3 SPI configuration

This section summarizes how the module has been configured in the chip. For a comprehensive description of the module itself, see the module's dedicated chapter.

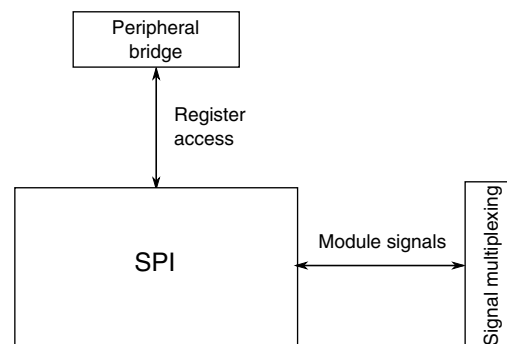

Figure 3-55. SPI configuration

Table 3-64. Reference links to related information

Topic	Related module	Reference
Full description	SPI	SPI
System memory map		System memory map
Clocking		Clock Distribution
Signal Multiplexing	Port control	Signal Multiplexing

3.9.3.1 SPI Modules Configuration

This device contains three SPI modules.

3.9.3.2 SPI clocking

The SPI module is clocked by the internal bus clock (the DSPI refers to it as system clock). The module has an internal divider, with a minimum divide is two. So, the SPI can run at a maximum frequency of bus clock/2.

3.9.3.3 Number of CTARs

SPI CTAR registers define different transfer attribute configurations. The SPI module supports up to eight CTAR registers. This device supports two CTARs on all instances of the SPI.

In master mode, the CTAR registers define combinations of transfer attributes, such as frame size, clock phase, clock polarity, data bit ordering, baud rate, and various delays. In slave mode only CTAR0 is used, and a subset of its bitfields sets the slave transfer attributes.

3.9.3.4 TX FIFO size

Table 3-65. SPI transmit FIFO size

SPI Module	Transmit FIFO size
SPI0	4
SPI1	4
SPI2	4

3.9.3.5 RX FIFO Size

SPI supports up to 16-bit frame size during reception.

Table 3-66. SPI receive FIFO size

SPI Module	Receive FIFO size
SPI0	4
SPI1	4
SPI2	4

3.9.3.6 Number of PCS signals

The following table shows the number of peripheral chip select signals available per SPI module.

Table 3-67. SPI PCS signals

SPI Module	PCS Signals
SPI0	SPI_PCS[5:0]
SPI1	SPI_PCS[3:0]
SPI2	SPI_PCS[1:0]

3.9.3.7 SPI Operation in Low Power Modes

In VLPR and VLPW modes the SPI is functional; however, the reduced system frequency also reduces the max frequency of operation for the SPI. In VLPR and VLPW modes the max SPI_CLK frequency is 1MHz.

In stop and VLPS modes, the clocks to the SPI module are disabled. The module is not functional, but it is powered so that it retains state.

There is one way to wake from stop mode via the SPI, which is explained in the following section.

3.9.3.7.1 Using GPIO Interrupt to Wake from stop mode

Here are the steps to use a GPIO to create a wakeup upon reception of SPI data in slave mode:

1. Point the GPIO interrupt vector to the desired interrupt handler.
2. Enable the GPIO input to generate an interrupt on either the rising or falling edge (depending on the polarity of the chip select signal).
3. Enter Stop or VLPS mode and Wait for the GPIO interrupt.

NOTE

It is likely that in using this approach the first word of data from the SPI host might not be received correctly. This is dependent on the transfer rate used for the SPI, the delay between chip select assertion and presentation of data, and the system interrupt latency.

3.9.3.8 SPI Doze Mode

The Doze mode for the SPI module is the same as the Wait and VLPW modes for the chip.

3.9.3.9 SPI Interrupts

The SPI has multiple sources of interrupt requests. However, these sources are OR'd together to generate a single interrupt request per SPI module to the interrupt controller. When an SPI interrupt occurs, read the SPI_SR to determine the exact interrupt source.

3.9.3.10 SPI clocks

This table shows the SPI module clocks and the corresponding chip clocks.

Table 3-68. SPI clock connections

Module clock	Chip clock
System Clock	Bus Clock

3.9.4 I2C Configuration

This section summarizes how the module has been configured in the chip. For a comprehensive description of the module itself, see the module's dedicated chapter.

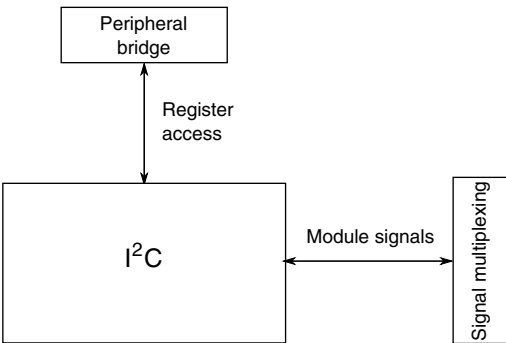

Figure 3-56. I2C configuration

Table 3-69. Reference links to related information

Topic	Related module	Reference
Full description	I ² C	I²C
System memory map		System memory map
Clocking		Clock Distribution
Power management		Power management
Signal Multiplexing	Port control	Signal Multiplexing

3.9.4.1 Number of I2C modules

This device has two I²C modules.

3.9.5 UART Configuration

This section summarizes how the module has been configured in the chip. For a comprehensive description of the module itself, see the module’s dedicated chapter.

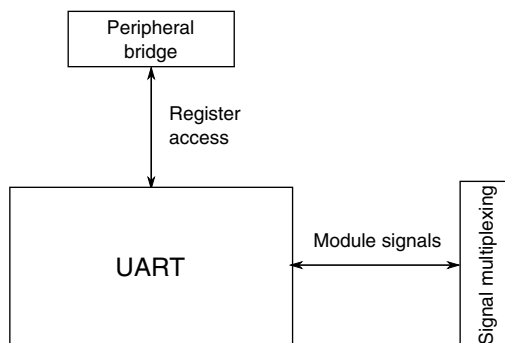

Figure 3-57. UART configuration

Table 3-70. Reference links to related information

Topic	Related module	Reference
Full description	UART	UART
System memory map		System memory map
Clocking		Clock Distribution
Power management		Power management
Signal Multiplexing	Port control	Signal Multiplexing

3.9.5.1 UART configuration information

This device contains five UART modules. This section describes how each module is configured on this device.

1. Standard features of all UARTs:
 - RS-485 support
 - Hardware flow control (RTS/CTS)
 - 9-bit UART to support address mark with parity
 - MSB/LSB configuration on data
2. UART0 and UART1 are clocked from the core clock, the remaining UARTs are clocked on the bus clock. The maximum baud rate is 1/16 of related source clock frequency.
3. IrDA is available on all UARTs
4. UART0 contains the standard features plus ISO7816
5. AMR support on all UARTs. The pin control and interrupts (PORT) module supports open-drain for all I/O.
6. UART0 and UART1 contains 8-entry transmit and 8-entry receive FIFOs
7. All other UARTs contain a 1-entry transmit and receive FIFOs

3.9.5.2 UART wakeup

The UART can be configured to generate an interrupt/wakeup on the first active edge that it receives.

3.9.5.3 UART interrupts

The UART has multiple sources of interrupt requests. However, some of these sources are OR'd together to generate a single interrupt request. See below for the mapping of the individual interrupt sources to the interrupt request:

The status interrupt combines the following interrupt sources:

Source	UART 0	UART 1	UART 2	UART 3	UART 4
Transmit data empty	x	x	x	x	x
Transmit complete	x	x	x	x	x
Idle line	x	x	x	x	x
Receive data full	x	x	x	x	x
LIN break detect	x	x	x	x	x
RxD pin active edge	x	x	x	x	x
Initial character detect	x	—	—	—	—

The error interrupt combines the following interrupt sources:

Source	UART 0	UART 1	UART 2	UART 3	UART 4
Receiver overrun	x	x	x	x	x
Noise flag	x	x	x	x	x
Framing error	x	x	x	x	x
Parity error	x	x	x	x	x
Transmitter buffer overflow	x	x	x	x	x
Receiver buffer underflow	x	x	x	x	x
Transmit threshold (ISO7816)	x	—	—	—	—
Receiver threshold (ISO7816)	x	—	—	—	—
Wait timer (ISO7816)	x	—	—	—	—
Character wait timer (ISO7816)	x	—	—	—	—

Table continues on the next page...

Source	UART 0	UART 1	UART 2	UART 3	UART 4
Block wait timer (ISO7816)	x	—	—	—	—
Guard time violation (ISO7816)	x	—	—	—	—

3.9.6 SDHC Configuration

This section summarizes how the module has been configured in the chip. For a comprehensive description of the module itself, see the module’s dedicated chapter.

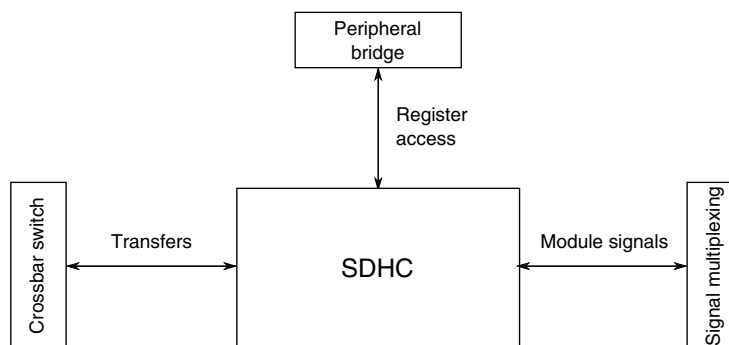

Figure 3-58. SDHC configuration

Table 3-71. Reference links to related information

Topic	Related module	Reference
Full description	SDHC	SDHC
System memory map		System memory map
Clocking		Clock Distribution
Power management		Power management
Transfers	Crossbar switch	Crossbar switch
Signal Multiplexing	Port control	Signal Multiplexing

3.9.6.1 SDHC clocking

In addition to the system clock, the SDHC needs a clock for the base for the external card clock. There are four possible clock sources for this clock, selected by the SIM’s SOPT2 register:

- Core/system clock
- MCGPLLCLK or MCGFLLCLK
- EXTAL
- Bypass clock from off-chip (SDHC0_CLKIN)

3.9.6.2 SD bus pullup/pulldown constraints

The SD standard requires the SD bus signals (except the SD clock) to be pulled up during data transfers. The SDHC also provides a feature of detecting card insertion/removal, by detecting voltage level changes on DAT[3] of the SD bus. To support this DAT[3] must be pulled down. To avoid a situation where the SDHC detects voltage changes due to normal data transfers on the SD bus as card insertion/removal, the interrupt relating to this event must be disabled after the card has been inserted and detected. It can be re-enabled after the card is removed.

3.9.7 I²S configuration

This section summarizes how the module has been configured in the chip. For a comprehensive description of the module itself, see the module's dedicated chapter.

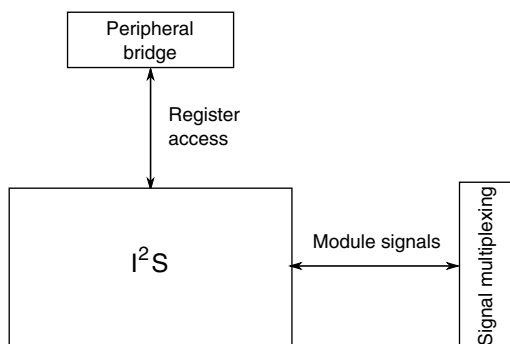

Figure 3-59. I²S configuration

Table 3-72. Reference links to related information

Topic	Related module	Reference
Full description	I ² S	I2S
System memory map		System memory map
Clocking		Clock Distribution
Power management		Power management
Signal multiplexing	Port control	Signal Multiplexing

NOTE

The I2S master clock can be output on the I2S0_MCLK pin or input on the I2S0_CLKIN pin. Using the I2S0_RX_BCLK pin to output the I2S master clock in synchronous mode is not supported on this device.

3.9.7.1 Interrupts

The interrupt outputs from the I²S module are OR'd to create a single interrupt to the interrupt control logic.

3.9.7.2 DMA requests

The I²S module has two DMA requests:

- Transmit FIFO
- Receive FIFO

3.9.7.3 I²S clock generation

To generate the desired frequencies for the I²S module there are multiple clocking options as shown below:

- The core/system clock is routed to an 8-bit fractional divider to generate the I²S clock.
- The PLL output is routed to an 8-bit fractional divider to generate the I²S clock.
- The EXTAL pin directly drives the I²S clock.
- The I2S0_CLKIN pin directly drives the I²S clock.

These options are controlled by the SIM_SOPT2[I2SSRC] field, and the 8-bit fractional divider is controlled by the SIM_CLKDIV2[I2SDIV, I2SFRAC] fields. See the [SIM module](#) for details.

3.9.7.4 I²S operation in low power modes

The I²S module requires interaction with the rest of the system to move data in or out of the FIFOs. Since the rest of the system is not active in stop, VLPS, and LLS modes, there is no use for the I²S in these modes. The I²S is powered so that it retains state in these modes, but it is not functional.

In VLPR and VLPW modes, the I²S is functional. However, the I²S is limited to 400 kHz maximum frequency.

3.10 Human-machine interfaces (HMI)

3.10.1 GPIO configuration

This section summarizes how the module has been configured in the chip. For a comprehensive description of the module itself, see the module’s dedicated chapter.

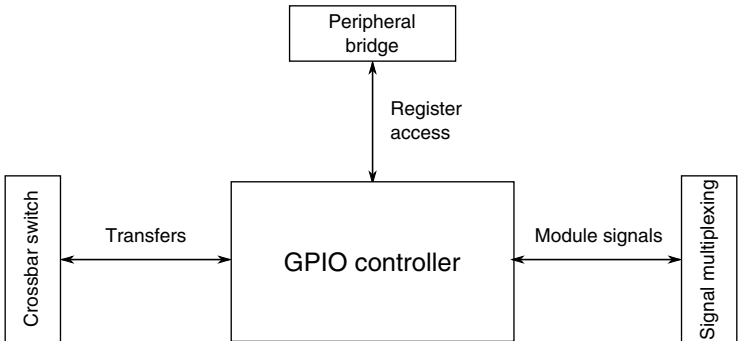

Figure 3-60. GPIO configuration

Table 3-73. Reference links to related information

Topic	Related module	Reference
Full description	GPIO	GPIO
System memory map		System memory map
Clocking		Clock Distribution
Power management		Power management
Transfers	Crossbar switch	Clock Distribution
Signal Multiplexing	Port control	Signal Multiplexing

3.10.1.1 GPIO access protection

The GPIO module does not have access protection because it is not connected to a peripheral bridge slot and is not protected by the MPU.

3.10.1.2 Number of GPIO signals

The number of GPIO signals available on the devices covered by this document are detailed in [Orderable part numbers](#).

3.10.2 TSI Configuration

This section summarizes how the module has been configured in the chip. For a comprehensive description of the module itself, see the module’s dedicated chapter.

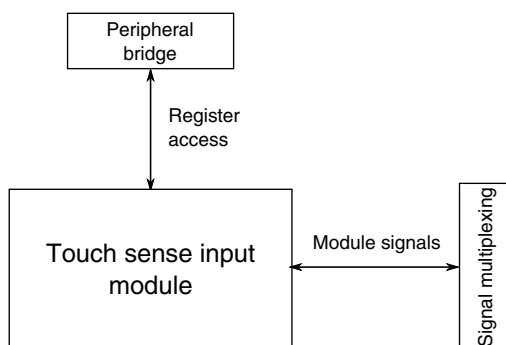

Figure 3-61. TSI configuration

Table 3-74. Reference links to related information

Topic	Related module	Reference
Full description	TSI	TSI
System memory map		System memory map
Clocking		Clock Distribution
Power management		Power management
Signal Multiplexing	Port control	Signal Multiplexing

3.10.2.1 Number of inputs

This device includes one TSI module containing 16 inputs. In low-power modes, one selectable pin is active.

3.10.2.2 TSI module functionality in MCU operation modes

Table 3-75. TSI module functionality in MCU operation modes

MCU operation mode	TSI clock sources	TSI operation mode when GENCS[TSIEN] is 1	Functional electrode pins	Required GENCS[STPE] state
Run	BUSCLK, MCGIRCLK, OSCERCLK	Active mode	All	Don't care
Wait	BUSCLK, MCGIRCLK, OSCERCLK	Active mode	All	Don't care

Table continues on the next page...

Table 3-75. TSI module functionality in MCU operation modes (continued)

MCU operation mode	TSI clock sources	TSI operation mode when GENCS[TSIEN] is 1	Functional electrode pins	Required GENCS[STPE] state
Stop	MCGIRCLK, OSCERCLK	Active mode	All	1
VLPR	BUSCLK, MCGIRCLK, OSCERCLK	Active mode	All	Don't care
VLPW	BUSCLK, MCGIRCLK, OSCERCLK	Active mode	All	Don't care
VLPS	OS CERCLK	Active mode	All	1
LLS	LPOCLK, VLPOSCCLK	Low power mode	Determined by PEN[LPSP]	1
VLLS3	LPOCLK, VLPOSCCLK	Low power mode	Determined by PEN[LPSP]	1
VLLS2	LPOCLK, VLPOSCCLK	Low power mode	Determined by PEN[LPSP]	1
VLLS1	LPOCLK, VLPOSCCLK	Low power mode	Determined by PEN[LPSP]	1

3.10.2.3 TSI clocks

This table shows the TSI clocks and the corresponding chip clocks.

Table 3-76. TSI clock connections

Module clock	Chip clock
BUSCLK	Bus clock
MCGIRCLK	MCGIRCLK
OS CERCLK	OS CERCLK
LPOCLK	1 kHz LPO clock
VLPOSCCLK	ERCLK32K

3.10.2.4 TSI Interrupts

The TSI has multiple sources of interrupt requests. However, these sources are OR'd together to generate a single interrupt request. When a TSI interrupt occurs, read the TSI status register to determine the exact interrupt source.

3.10.2.5 Shield drive signal

The shield drive signal is not supported on this device. Ignore this feature in the TSI chapter.

3.10.3 Segment LCD Configuration

This section summarizes how the module has been configured in the chip. For a comprehensive description of the module itself, see the module’s dedicated chapter.

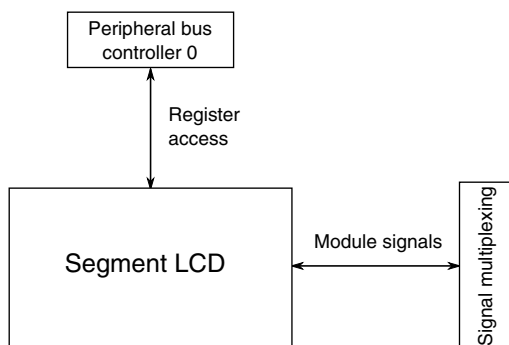

Figure 3-62. SLCD configuration

Table 3-77. Reference links to related information

Topic	Related module	Reference
Full description	Segment LCD	Segment LCD
System memory map		System memory map
Clocking		Clock distribution
Power management		Power management
Signal multiplexing	Port control	Signal multiplexing

3.10.3.1 Instantiation information

The following table lists the Segment LCD (SLCD) support information.

Table 3-78. SLCD support¹

Max. number of segments	Configurations
Up to 256	Up to 8 backplanes and up to 36 frontplanes

1. The LCD controller can support multiplexing from x1 up to x8.

3.10.3.2 LCD pin assignments

Configure the mux control registers to assign the corresponding module function to a pin. For normal operation of the LCD, use ALT0 LCD functions. The ALT7 LCD functions are only available for LCD fault detection.

See the [Signal Multiplexing and Signal Descriptions](#) chapter for the number of LCD pins used in this MCU.

3.10.3.3 LCD pin enable, backplane enable, and waveform registers

The following table shows the comparison of LCD pin enable, backplane enable, and waveform registers at the module and chip level.

Table 3-79. LCD pin enable, backplane enable, and waveform registers

Register	Module range	Chip range
PENn	PENL contains PEN[31:0] PENH contains PEN[63:32]	PENL contains PEN[31:0] PENH contains PEN[39:32]
BPENn	BPENL contains BPEN[31:0] BPENH contains BPEN[63:32]	BPENL contains BPEN[31:0] BPENH contains BPEN[39:32]
WFyTOx	WF3to0 – WF63to60	WF3to0 – WF39to36

3.10.3.4 LCD clock source

The following table shows the LCD clock and the corresponding chip clock source.

Table 3-80. LCD clock source

Module clock	Chip clock
Default clock (external crystal or reference clock)	Default clock is either the system OSC output clock (OSCOUTCLK) or RTC OSC output clock (RTCOUTCLK). This is selected by SOPT1[OSC32KSEL] bit in SIM module. The clock defaults to 32 kHz.
Alternate clock	Alternate clock is the MCGIRCLK output that is either the 32 kHz or 2 MHz internal reference clocks. This option is selected by the user in the MCG module. The clock defaults to 32 kHz.

3.10.3.5 Segment LCD Interrupts

The Segment LCD has multiple interrupt sources. However, all of these sources are OR'd together to generate a single interrupt request. Read the LFDSR and LGCR registers to determine the cause of the interrupt.

Chapter 4 Memory Map

4.1 Introduction

This device contains various memories and memory-mapped peripherals which are located in one 32-bit contiguous memory space. This chapter describes the memory and peripheral locations within that memory space.

4.2 System memory map

The following table shows the high-level device memory map.

Table 4-1. System memory map

System 32-bit Address Range	Destination Slave	Access
0x0000_0000–0x0FFF_FFFF	Program flash and read-only data (Includes exception vectors in first 1024 bytes)	All masters
0x1000_0000–0x13FF_FFFF	• Reserved	All masters
0x1400_0000–0x17FF_FFFF	Programming acceleration RAM	All masters
0x1800_0000–0x1FFF_FFFF	SRAM_L: Lower SRAM (ICODE/DCODE)	All masters
0x2000_0000–0x200F_FFFF	SRAM_U: Upper SRAM bitband region	All masters
0x2010_0000–0x21FF_FFFF	Reserved	–
0x2200_0000–0x23FF_FFFF	Aliased to SRAM_U bitband	Cortex-M4 core only
0x2400_0000–0x3FFF_FFFF	Reserved	–
0x4000_0000–0x4007_FFFF	Bitband region for peripheral bridge 0 (AIPS-Lite0)	Cortex-M4 core & DMA/EzPort
0x4008_0000–0x400F_EFFF	Bitband region for peripheral bridge 1 (AIPS-Lite1)	Cortex-M4 core & DMA/EzPort
0x400F_F000–0x400F_FFFF	Bitband region for general purpose input/output (GPIO)	Cortex-M4 core & DMA/EzPort

Table continues on the next page...

Table 4-1. System memory map (continued)

System 32-bit Address Range	Destination Slave	Access
0x4010_0000–0x41FF_FFFF	Reserved	–
0x4200_0000–0x43FF_FFFF	Aliased to peripheral bridge (AIPS-Lite) and general purpose input/output (GPIO) bitband	Cortex-M4 core only
0x4400_0000–0xDFFF_FFFF	Reserved	–
0xE000_0000–0xE00F_FFFF	Private peripherals	Cortex-M4 core only
0xE010_0000–0xFFFF_FFFF	Reserved	–

NOTE

1. EzPort master port is statically muxed with DMA master port. Access rights to AIPS-Lite peripheral bridges and general purpose input/output (GPIO) module address space is limited to the core, DMA, and EzPort.
2. ARM Cortex-M4 core access privileges also includes accesses via the debug interface.

4.2.1 Aliased bit-band regions

The SRAM_U, AIPS-Lite, and general purpose input/output (GPIO) module resources reside in the Cortex-M4 processor bit-band regions.

The processor also includes two 32 MB aliased bit-band regions associated with the two 1 MB bit-band spaces. Each 32-bit location in the 32 MB space maps to an individual bit in the bit-band region. A 32-bit write in the alias region has the same effect as a read-modify-write operation on the targeted bit in the bit-band region.

Bit 0 of the value written to the alias region determines what value is written to the target bit:

- Writing a value with bit 0 set writes a 1 to the target bit.
- Writing a value with bit 0 clear writes a 0 to the target bit.

A 32-bit read in the alias region returns either:

- a value of 0x0000_0000 to indicate the target bit is clear
- a value of 0x0000_0001 to indicate the target bit is set

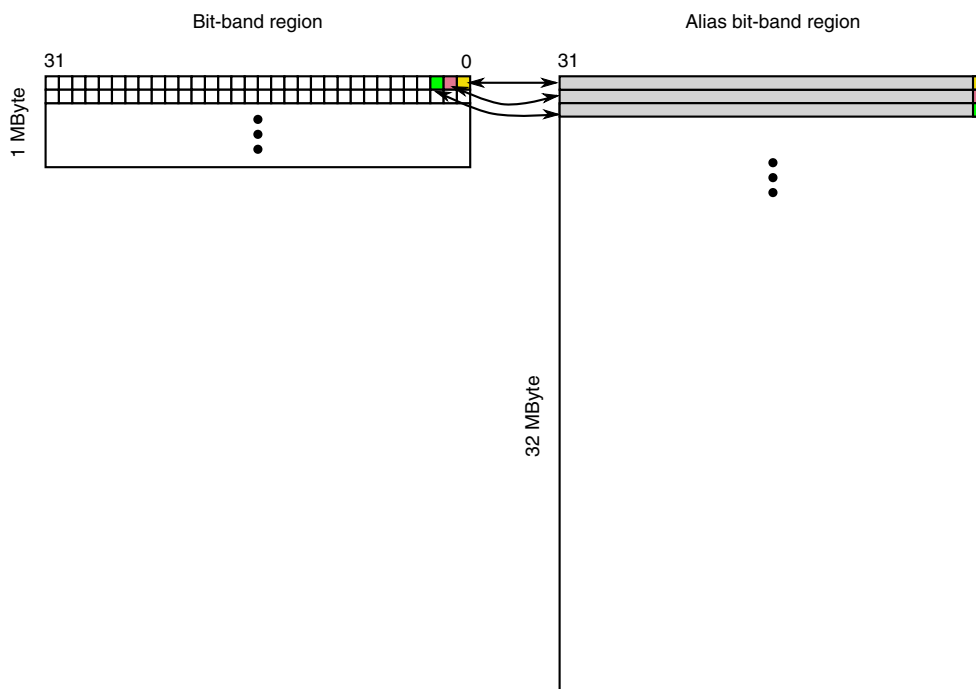

Figure 4-1. Alias bit-band mapping

NOTE

Each bit in bit-band region has an equivalent bit that can be manipulated through bit 0 in a corresponding long word in the alias bit-band region.

4.3 Flash Memory Map

The various flash memories and the flash registers are located at different base addresses as shown in the following figure. The base address for each is specified in [System memory map](#).

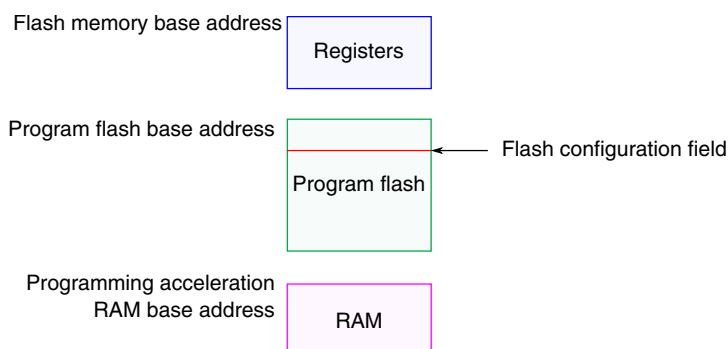

Figure 4-2. Flash memory map

4.3.1 Alternate Non-Volatile IRC User Trim Description

The following non-volatile locations (4 bytes) are reserved for custom IRC user trim supported by some development tools. An alternate IRC trim to the factory loaded trim can be stored at this location. To override the factory trim, user software must load new values into the MCG trim registers.

Non-Volatile Byte Address	Alternate IRC Trim Value
0x0000_03FC	Reserved
0x0000_03FD	Reserved
0x0000_03FE (bit 0)	SCFTRIM
0x0000_03FE (bit 4:1)	FCTRIM
0x0000_03FF	SCTRIM

4.4 SRAM memory map

The on-chip RAM is split evenly among SRAM_L and SRAM_U. The RAM is also implemented such that the SRAM_L and SRAM_U ranges form a contiguous block in the memory map. See [SRAM Arrays](#) for details.

Accesses to the SRAM_L and SRAM_U memory ranges outside the amount of RAM on the device causes the bus cycle to be terminated with an error followed by the appropriate response in the requesting bus master.

4.5 Peripheral bridge (AIPS-Lite0 and AIPS-Lite1) memory maps

The peripheral memory map is accessible via two slave ports on the crossbar switch in the 0x4000_0000–0x400F_FFFF region. The device implements two peripheral bridges (AIPS-Lite 0 and 1):

- AIPS-Lite0 covers 512 KB
- AIPS-Lite1 covers 508 KB with 4 KB assigned to the general purpose input/output module (GPIO)

AIPS-Lite0 is connected to crossbar switch slave port 2, and is accessible at locations 0x4000_0000–0x4007_FFFF.

AIPS-Lite1 and the general purpose input/output module share the connection to crossbar switch slave port 3. The AIPS-Lite1 is accessible at locations 0x4008_0000–0x400F_EFFF. The general purpose input/output module is accessible in a 4-kbyte region at 0x400F_F000–0x400F_FFFF. Its direct connection to the crossbar switch provides master access without incurring wait states associated with accesses via the AIPS-Lite controllers.

Modules that are disabled via their clock gate control bits in the SIM registers disable the associated AIPS slots. Access to any address within an unimplemented or disabled peripheral bridge slot results in a transfer error termination.

For programming model accesses via the peripheral bridges, there is generally only a small range within the 4 KB slots that is implemented. Accessing an address that is not implemented in the peripheral results in a transfer error termination.

4.5.1 Peripheral Bridge 0 (AIPS-Lite 0) Memory Map

Table 4-2. Peripheral bridge 0 slot assignments

System 32-bit base address	Slot number	Module
0x4000_0000	0	Peripheral bridge 0 (AIPS-Lite 0)
0x4000_1000	1	—
0x4000_2000	2	—
0x4000_3000	3	—
0x4000_4000	4	Crossbar switch
0x4000_5000	5	—
0x4000_6000	6	—
0x4000_7000	7	—
0x4000_8000	8	DMA controller
0x4000_9000	9	DMA controller transfer control descriptors
0x4000_A000	10	—
0x4000_B000	11	—
0x4000_C000	12	—
0x4000_D000	13	MPU
0x4000_E000	14	—
0x4000_F000	15	—
0x4001_0000	16	—
0x4001_1000	17	—
0x4001_2000	18	—

Table continues on the next page...

Table 4-2. Peripheral bridge 0 slot assignments (continued)

System 32-bit base address	Slot number	Module
0x4001_3000	19	—
0x4001_4000	20	—
0x4001_5000	21	—
0x4001_6000	22	—
0x4001_7000	23	—
0x4001_8000	24	—
0x4001_9000	25	—
0x4001_A000	26	—
0x4001_B000	27	—
0x4001_C000	28	—
0x4001_D000	29	—
0x4001_E000	30	—
0x4001_F000	31	Flash memory controller
0x4002_0000	32	Flash memory
0x4002_1000	33	DMA channel mutiplexer 0
0x4002_2000	34	—
0x4002_3000	35	—
0x4002_4000	36	FlexCAN 0
0x4002_5000	37	—
0x4002_6000	38	—
0x4002_7000	39	—
0x4002_8000	40	—
0x4002_9000	41	—
0x4002_A000	42	—
0x4002_B000	43	—
0x4002_C000	44	SPI 0
0x4002_D000	45	SPI 1
0x4002_E000	46	—
0x4002_F000	47	I2S 0
0x4003_0000	48	—
0x4003_1000	49	—
0x4003_2000	50	CRC
0x4003_3000	51	—
0x4003_4000	52	—

Table continues on the next page...

Table 4-2. Peripheral bridge 0 slot assignments (continued)

System 32-bit base address	Slot number	Module
0x4003_5000	53	USB DCD
0x4003_6000	54	Programmable delay block (PDB)
0x4003_7000	55	Periodic interrupt timers (PIT)
0x4003_8000	56	FlexTimer (FTM) 0
0x4003_9000	57	FlexTimer (FTM) 1
0x4003_A000	58	—
0x4003_B000	59	Analog-to-digital converter (ADC) 0
0x4003_C000	60	—
0x4003_D000	61	Real-time clock (RTC)
0x4003_E000	62	VBAT register file
0x4003_F000	63	—
0x4004_0000	64	Low-power timer (LPTMR)
0x4004_1000	65	System register file
0x4004_2000	66	DryIce
0x4004_3000	67	DryIce secure storage
0x4004_4000	68	—
0x4004_5000	69	Touch sense interface (TSI)
0x4004_6000	70	—
0x4004_7000	71	SIM low-power logic
0x4004_8000	72	System integration module (SIM)
0x4004_9000	73	Port A multiplexing control
0x4004_A000	74	Port B multiplexing control
0x4004_B000	75	Port C multiplexing control
0x4004_C000	76	Port D multiplexing control
0x4004_D000	77	Port E multiplexing control
0x4004_E000	78	—
0x4004_F000	79	—
0x4005_0000	80	—
0x4005_1000	81	—
0x4005_2000	82	Software watchdog
0x4005_3000	83	—
0x4005_4000	84	—
0x4005_5000	85	—
0x4005_6000	86	—

Table continues on the next page...

Table 4-2. Peripheral bridge 0 slot assignments (continued)

System 32-bit base address	Slot number	Module
0x4005_7000	87	—
0x4005_8000	88	—
0x4005_9000	89	—
0x4005_A000	90	—
0x4005_B000	91	—
0x4005_C000	92	—
0x4005_D000	93	—
0x4005_E000	94	—
0x4005_F000	95	—
0x4006_0000	96	—
0x4006_1000	97	External watchdog
0x4006_2000	98	Carrier modulator timer (CMT)
0x4006_3000	99	—
0x4006_4000	100	Multi-purpose Clock Generator (MCG)
0x4006_5000	101	System oscillator (OSC)
0x4006_6000	102	I ² C 0
0x4006_7000	103	I ² C 1
0x4006_8000	104	
0x4006_9000	105	—
0x4006_A000	106	UART 0
0x4006_B000	107	UART 1
0x4006_C000	108	UART 2
0x4006_D000	109	UART 3
0x4006_E000	110	—
0x4006_F000	111	—
0x4007_0000	112	—
0x4007_1000	113	—
0x4007_2000	114	USB OTG FS/LS
0x4007_3000	115	Analog comparator (CMP) / 6-bit digital-to-analog converter (DAC)
0x4007_4000	116	Voltage reference (VREF)
0x4007_5000	117	—
0x4007_6000	118	—
0x4007_7000	119	—
0x4007_8000	120	—

Table continues on the next page...

Table 4-2. Peripheral bridge 0 slot assignments (continued)

System 32-bit base address	Slot number	Module
0x4007_9000	121	—
0x4007_A000	122	—
0x4007_B000	123	—
0x4007_C000	124	Low-leakage wakeup unit (LLWU)
0x4007_D000	125	Power management controller (PMC)
0x4007_E000	126	System Mode controller (SMC)
0x4007_F000	127	—

4.5.2 Peripheral Bridge 1 (AIPS-Lite 1) Memory Map

Table 4-3. Peripheral bridge 1 slot assignments

System 32-bit base address	Slot number	Module
0x4008_0000	0	Peripheral bridge 1 (AIPS-Lite 1)
0x4008_1000	1	—
0x4008_2000	2	—
0x4008_3000	3	—
0x4008_4000	4	—
0x4008_5000	5	—
0x4008_6000	6	—
0x4008_7000	7	—
0x4008_8000	8	—
0x4008_9000	9	—
0x4008_A000	10	—
0x4008_B000	11	—
0x4008_C000	12	—
0x4008_D000	13	—
0x4008_E000	14	—
0x4008_F000	15	—
0x4009_0000	16	—
0x4009_1000	17	—
0x4009_2000	18	—
0x4009_3000	19	—
0x4009_4000	20	—

Table continues on the next page...

Table 4-3. Peripheral bridge 1 slot assignments (continued)

System 32-bit base address	Slot number	Module
0x4009_5000	21	—
0x4009_6000	22	—
0x4009_7000	23	—
0x4009_8000	24	—
0x4009_9000	25	—
0x4009_A000	26	—
0x4009_B000	27	—
0x4009_C000	28	—
0x4009_D000	29	—
0x4009_E000	30	—
0x4009_F000	31	—
0x400A_0000	32	—
0x400A_1000	33	—
0x400A_2000	34	—
0x400A_3000	35	—
0x400A_4000	36	FlexCAN 1
0x400A_5000	37	—
0x400A_6000	38	—
0x400A_7000	39	—
0x400A_8000	40	—
0x400A_9000	41	—
0x400A_A000	42	—
0x400A_B000	43	—
0x400A_C000	44	SPI 2
0x400A_D000	45	—
0x400A_E000	46	—
0x400A_F000	47	—
0x400B_0000	48	—
0x400B_1000	49	SDHC
0x400B_2000	50	—
0x400B_3000	51	—
0x400B_4000	52	—
0x400B_5000	53	—
0x400B_6000	54	—

Table continues on the next page...

Table 4-3. Peripheral bridge 1 slot assignments (continued)

System 32-bit base address	Slot number	Module
0x400B_7000	55	—
0x400B_8000	56	FlexTimer (FTM) 2
0x400B_9000	57	—
0x400B_A000	58	—
0x400B_B000	59	Analog-to-digital converter (ADC) 1
0x400B_C000	60	—
0x400B_D000	61	—
0x400B_E000	62	Segment LCD
0x400B_F000	63	—
0x400C_0000	64	—
0x400C_1000	65	—
0x400C_2000	66	—
0x400C_3000	67	—
0x400C_4000	68	—
0x400C_5000	69	—
0x400C_6000	70	—
0x400C_7000	71	—
0x400C_8000	72	—
0x400C_9000	73	—
0x400C_A000	74	—
0x400C_B000	75	—
0x400C_C000	76	12-bit digital-to-analog converter (DAC) 0
0x400C_D000	77	—
0x400C_E000	78	—
0x400C_F000	79	—
0x400D_0000	80	—
0x400D_1000	81	—
0x400D_2000	82	—
0x400D_3000	83	—
0x400D_4000	84	—
0x400D_5000	85	—
0x400D_6000	86	—
0x400D_7000	87	—
0x400D_8000	88	—

Table continues on the next page...

Table 4-3. Peripheral bridge 1 slot assignments (continued)

System 32-bit base address	Slot number	Module
0x400D_9000	89	—
0x400D_A000	90	—
0x400D_B000	91	—
0x400D_C000	92	—
0x400D_D000	93	—
0x400D_E000	94	—
0x400D_F000	95	—
0x400E_0000	96	—
0x400E_1000	97	—
0x400E_2000	98	—
0x400E_3000	99	—
0x400E_4000	100	—
0x400E_5000	101	—
0x400E_6000	102	—
0x400E_7000	103	—
0x400E_8000	104	—
0x400E_9000	105	—
0x400E_A000	106	UART 4
0x400E_B000	107	—
0x400E_C000	108	—
0x400E_D000	109	—
0x400E_E000	110	—
0x400E_F000	111	—
0x400F_0000	112	—
0x400F_1000	113	—
0x400F_2000	114	—
0x400F_3000	115	—
0x400F_4000	116	—
0x400F_5000	117	—
0x400F_6000	118	—
0x400F_7000	119	—
0x400F_8000	120	—
0x400F_9000	121	—
0x400F_A000	122	—

Table continues on the next page...

Table 4-3. Peripheral bridge 1 slot assignments (continued)

System 32-bit base address	Slot number	Module
0x400F_B000	123	—
0x400F_C000	124	—
0x400F_D000	125	—
0x400F_E000	126	—
0x400F_F000	Not an AIPS-Lite slot. The 32-bit general purpose input/output module that shares the crossbar switch slave port with the AIPS-Lite is accessed at this address.	

4.6 Private Peripheral Bus (PPB) memory map

The PPB is part of the defined ARM bus architecture and provides access to select processor-local modules. These resources are only accessible from the core; other system masters do not have access to them.

Table 4-4. PPB memory map

System 32-bit Address Range	Resource
0xE000_0000–0xE000_0FFF	Instrumentation Trace Macrocell (ITM)
0xE000_1000–0xE000_1FFF	Data Watchpoint and Trace (DWT)
0xE000_2000–0xE000_2FFF	Flash Patch and Breakpoint (FPB)
0xE000_3000–0xE000_DFFF	Reserved
0xE000_E000–0xE000_EFFF	System Control Space (SCS) (for NVIC)
0xE000_F000–0xE003_FFFF	Reserved
0xE004_0000–0xE004_0FFF	Trace Port Interface Unit (TPIU)
0xE004_1000–0xE004_1FFF	Embedded Trace Macrocell (ETM)
0xE004_2000–0xE004_2FFF	Embedded Trace Buffer (ETB)
0xE004_3000–0xE004_3FFF	Embedded Trace Funnel
0xE004_4000–0xE007_FFFF	Reserved
0xE008_0000–0xE008_0FFF	Miscellaneous Control Module (MCM)(including ETB Almost Full)
0xE008_1000–0xE008_1FFF	Reserved
0xE008_2000–0xE00F_EFFF	Reserved
0xE00F_F000–0xE00F_FFFF	ROM Table - allows auto-detection of debug components

Chapter 5

Clock Distribution

5.1 Introduction

The MCG module controls which clock source is used to derive the system clocks. The clock generation logic divides the selected clock source into a variety of clock domains, including the clocks for the system bus masters, system bus slaves, and flash memory. The clock generation logic also implements module-specific clock gating to allow granular shutoff of modules.

The primary clocks for the system are generated from the MCGOUTCLK clock. The clock generation circuitry provides several clock dividers that allow different portions of the device to be clocked at different frequencies. This allows for trade-offs between performance and power dissipation.

Various modules, such as the USB OTG Controller, have module-specific clocks that can be generated from the MCGPLLCLK or MCGFLLCLK clock. In addition, there are various other module-specific clocks that have other alternate sources. Clock selection for most modules is controlled by the SOPT registers in the SIM module.

5.2 Programming model

The selection and multiplexing of system clock sources is controlled and programmed via the MCG module. The setting of clock dividers and module clock gating for the system are programmed via the SIM module. Reference those sections for detailed register and bit descriptions.

5.3 High-Level device clocking diagram

The following [system oscillator](#), [MCG](#), and [SIM](#) module registers control the multiplexers, dividers, and clock gates shown in the below figure:

Clock definitions

	OSC	MCG	SIM
Multiplexers	MCG_Cx	MCG_Cx	SIM_SOPT1, SIM_SOPT2
Dividers	—	MCG_Cx	SIM_CLKDIVx
Clock gates	OSC_CR	MCG_C1	SIM_SCGCx

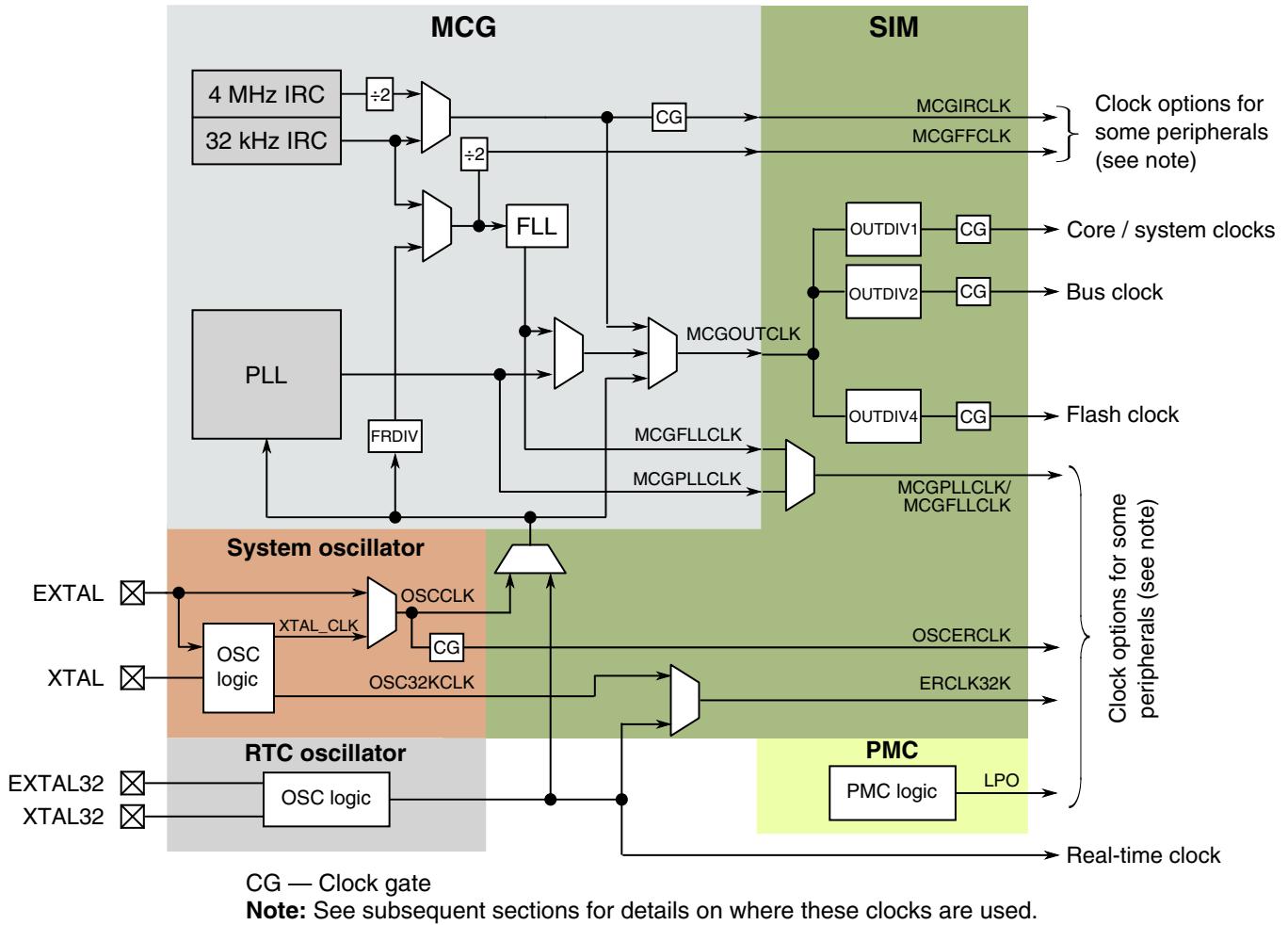

Figure 5-1. Clocking diagram

5.4 Clock definitions

The following table describes the clocks in the previous block diagram.

Clock name	Description
Core clock	MCGOUTCLK divided by OUTDIV1 clocks the ARM Cortex-M4 core
System clock	MCGOUTCLK divided by OUTDIV1 clocks the crossbar switch and bus masters directly connected to the crossbar. In addition, this clock is used for UART0 and UART1.

Table continues on the next page...

Clock name	Description
Bus clock	MCGOUTCLK divided by OUTDIV2 clocks the bus slaves and peripheral (excluding memories)
Flash clock	MCGOUTCLK divided by OUTDIV4 clocks the flash memory
MCGIRCLK	MCG output of the slow or fast internal reference clock
MCGFFCLK	MCG output of the slow internal reference clock or a divided MCG external reference clock. The MCGFFCLK is further divided by 2 before being made available to modules outside the MCG (as shown in the preceding figure).
MCGOUTCLK	MCG output of either IRC, MCGFLLCLK, MCGPLLCLK, or MCG's external reference clock that sources the core, system, bus, and flash clock. It is also an option for the debug trace clock.
MCGFLLCLK	MCG output of the FLL. MCGFLLCLK or MCGPLLCLK may clock some modules.
MCGPLLCLK	MCG output of the PLL. MCGFLLCLK or MCGPLLCLK may clock some modules.
MCG external reference clock	Input clock to the MCG sourced by the system oscillator (OSCCLK) or RTC oscillator
OSCCLK	System oscillator output of the internal oscillator or sourced directly from EXTAL
OSCERCLK	System oscillator output sourced from OSCCLK that may clock some on-chip modules
OSC32KCLK	System oscillator 32kHz output
ERCLK32K	Clock source for some modules that is chosen as OSC32KCLK or the RTC clock
RTC clock	RTC oscillator output for the RTC module
LPO	PMC 1kHz output

5.4.1 Device clock summary

The following table provides more information regarding the on-chip clocks.

Table 5-1. Clock Summary

Clock name	Run mode clock frequency	VLPR mode clock frequency	Clock source	Clock is disabled when...
MCGOUTCLK	Up to 100 MHz	Up to 2 MHz	MCG	In all stop modes
Core clock	Up to 100 MHz	Up to 2 MHz	MCGOUTCLK clock divider	In all wait and stop modes
System clock	Up to 100 MHz	Up to 2 MHz	MCGOUTCLK clock divider	In all stop modes
Bus clock	Up to 50 MHz	Up to 2 MHz	MCGOUTCLK clock divider	In all stop modes
Flash clock	Up to 25 MHz	Up to 1 MHz	MCGOUTCLK clock divider	In all stop modes

Table continues on the next page...

Table 5-1. Clock Summary (continued)

Clock name	Run mode clock frequency	VLPR mode clock frequency	Clock source	Clock is disabled when...
Internal reference (MCGIRCLK)	30-40 kHz or 2 MHz	2 MHz only	MCG	MCG_C1[IRCLKEN] cleared, Stop mode and MCG_C1[IREFSTEN] cleared, or VLPS/LLS/VLLS mode
External reference (OSCERCLK)	Up to 50 MHz (bypass), 30-40 kHz, or 4-32 MHz (crystal)	Up to 4 MHz (bypass), 30-40 kHz (low-range crystal) or Up to 4 MHz (high-range crystal)	System OSC	System OSC's OSC_CR[ERCLKEN] cleared, or Stop mode and OSC_CR[EREFSTEN] cleared
External reference 32kHz (ERCLK32K)	30-40 kHz	30-40 kHz	System OSC or RTC OSC depending on SIM_SOPT1[OSC32K SEL]	System OSC's OSC_CR[ERCLKEN] cleared or RTC's RTC_CR[OSCE] cleared
RTC_CLKOUT	1 Hz	1 Hz	RTC clock	Clock is disabled in LLS and VLLSx modes
LPO	1 kHz	1 kHz	PMC	Available in all power modes
USB FS clock	48 MHz	N/A	MCGPLLCLK or MCGFLLCLK with fractional clock divider, or USB_CLKIN	USB FS OTG is disabled
I2S master clock	Up to 50 MHz	N/A	System clock, MCGPLLCLK, or MCGFLLCLK with fractional clock divider, OSCERCLK, or I2S_CLKIN	I2S is disabled
SDHC clock	Up to 50 MHz	N/A	System clock, MCGPLLCLK/ MCGFLLCLK, or OSCERCLK	SDHC is disabled
TRACE clock	Up to 100 MHz	Up to 2 MHz	System clock or MCGOUTCLK	Trace is disabled

5.5 Internal clocking requirements

The clock dividers are programmed via the SIM module's CLKDIV registers. Each divider is programmable from a divide-by-1 through divide-by-16 setting. The following requirements must be met when configuring the clocks for this device:

1. The core and system clock frequencies must be 100 MHz or slower.
2. The bus clock frequency must be programmed to 50 MHz or less and an integer divide of the core clock.
3. The flash clock frequency must be programmed to 25 MHz or less and an integer divide of the bus clock.

The following are a few of the more common clock configurations for this device:

Option 1:

Clock	Frequency
Core clock	50 MHz
System clock	50 MHz
Bus clock	50 MHz
Flash clock	25 MHz

Option 2:

Clock	Frequency
Core clock	100 MHz
System clock	100 MHz
Bus clock	50 MHz
Flash clock	25 MHz

Option 3:

Clock	Frequency
Core clock	96 MHz
System clock	96 MHz
Bus clock	48 MHz
Flash clock	24 MHz

5.5.1 Clock divider values after reset

Each clock divider is programmed via the SIM module's CLKDIV n registers. The flash memory's FTFL_FOPT[LPBOOT] bit controls the reset value of the core clock, system clock, bus clock, and flash clock dividers as shown below:

FTFL_FOPT [LPBOOT]	Core/system clock	Bus clock	Flash clock	Description
0	0x7 (divide by 8)	0x7 (divide by 8)	0xF (divide by 16)	Low power boot
1	0x0 (divide by 1)	0x0 (divide by 1)	0x1 (divide by 2)	Fast clock boot

This gives the user flexibility for a lower frequency, low-power boot option. The flash erased state defaults to fast clocking mode, since where the low power boot (FTFL_FOPT[LPBOOT]) bit resides in flash is logic 1 in the flash erased state.

To enable the low power boot option program FTFL_FOPT[LPBOOT] to zero. During the reset sequence, if LPBOOT is cleared, the system is in a slow clock configuration. Upon any system reset, the clock dividers return to this configurable reset state.

5.5.2 VLPR mode clocking

The clock dividers cannot be changed while in VLPR mode. They must be programmed prior to entering VLPR mode to guarantee:

- the core/system and bus clocks are less than or equal to 2 MHz, and
- the flash memory clock is less than or equal to 1 MHz

5.6 Clock Gating

The clock to each module can be individually gated on and off using the SIM module's SCGC x registers. These bits are cleared after any reset, which disables the clock to the corresponding module to conserve power. Prior to initializing a module, set the corresponding bit in SCGC x register to enable the clock. Before turning off the clock, make sure to disable the module.

Any bus access to a peripheral that has its clock disabled generates an error termination.

5.7 Module clocks

The following table summarizes the clocks associated with each module.

Table 5-2. Module clocks

Module	Bus interface clock	Internal clocks	I/O interface clocks
Core modules			
ARM Cortex-M4 core	System clock	Core clock	—
NVIC	System clock	—	—
DAP	System clock	—	—
ITM	System clock	—	—
ETM	System clock	TRACE clock	TRACE_CLKOUT
ETB	System clock	—	—
cJTAG, JTAGC	—	—	JTAG_CLK
System modules			
DMA	System clock	—	—
DMA Mux	Bus clock	—	—
Port control	Bus clock	LPO	—
Crossbar Switch	System clock	—	—
Peripheral bridges	System clock	Bus clock	—
MPU	System clock	—	—
LLWU, PMC, SIM	Bus clock	LPO	—
Mode controller	Bus clock	—	—
MCM	System clock	—	—
EWM	Bus clock	LPO	—
Watchdog timer	Bus clock	LPO	—
Clocks			
MCG	Bus clock	MCGOUTCLK, MCGPLLCLK, MCGFLLCLK, MCGIRCLK, OSCERCLK	—
OSC	Bus clock	OSCERCLK	—
Memory and memory interfaces			
Flash Controller	System clock	Flash clock	—
Flash memory	Flash clock	—	—
EzPort	System clock	—	EZP_CLK
Security			
CRC	Bus clock	—	—
Analog			
ADC	Bus clock	OSCERCLK	—
CMP	Bus clock	—	—
DAC	Bus clock	—	—
VREF	Bus clock	—	—

Table continues on the next page...

Table 5-2. Module clocks (continued)

Module	Bus interface clock	Internal clocks	I/O interface clocks
Timers			
PDB	Bus clock	—	—
FlexTimers	Bus clock	MCGFFCLK	FTM_CLKINx
PIT	Bus clock	—	—
LPTMR	Bus clock	LPO, OSCERCLK, MCGIRCLK, ERCLK32K	—
CMT	Bus clock	—	—
RTC	Bus clock	EXTAL32	—
Communication interfaces			
USB FS OTG	System clock	USB FS clock	—
USB DCD	Bus clock	—	—
FlexCAN	Bus clock	OSCERCLK	—
DSPI	Bus clock	—	DSPI_SCK
I ² C	Bus clock	—	I2C_SCL
UART0, UART1	System clock	—	—
UART2-4	Bus clock	—	—
SDHC	System clock	SDHC clock	SDHC_DCLK
I ² S	Bus clock	I ² S master clock	I2S_TX_BCLK, I2S_RX_BCLK
Human-machine interfaces			
GPIO	System clock	—	—
TSI	Bus clock	LPO, ERCLK32K, MCGIRCLK	—
Segment LCD	Bus clock	ERCLK32K, MCGIRCLK	—

5.7.1 PMC 1-kHz LPO clock

The Power Management Controller (PMC) generates a 1-kHz clock that is enabled in all modes of operation, including all low power modes. This 1-kHz source is commonly referred to as LPO clock or 1-kHz LPO clock.

5.7.2 WDOG clocking

The WDOG may be clocked from two clock sources as shown in the following figure.

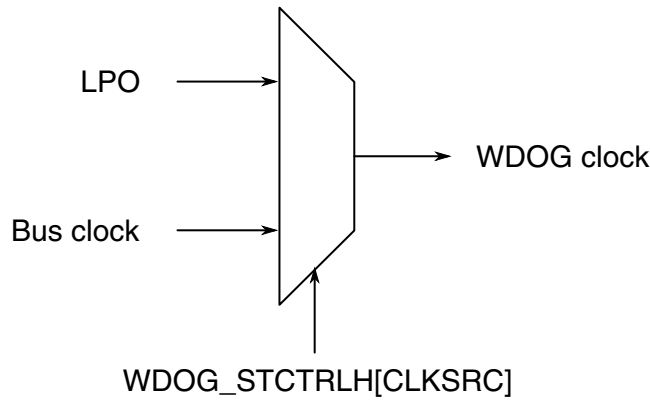

Figure 5-2. WDOG clock generation

5.7.3 Debug trace clock

The debug trace clock source can be clocked as shown in the following figure.

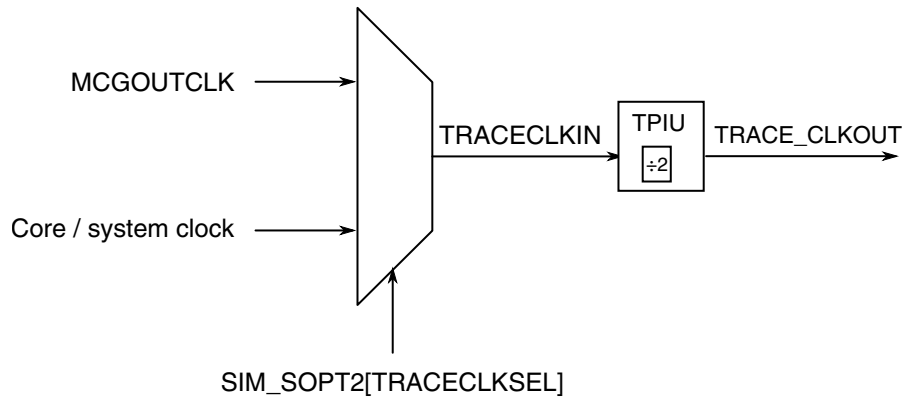

Figure 5-3. Trace clock generation

NOTE

The trace clock frequency observed at the TRACE_CLKOUT pin will be half that of the selected clock source.

5.7.4 PORT digital filter clocking

The digital filters in each of the PORT_x modules can be clocked as shown in the following figure.

NOTE

In stop mode, the digital input filters are bypassed unless they are configured to run from the 1 kHz LPO clock source.

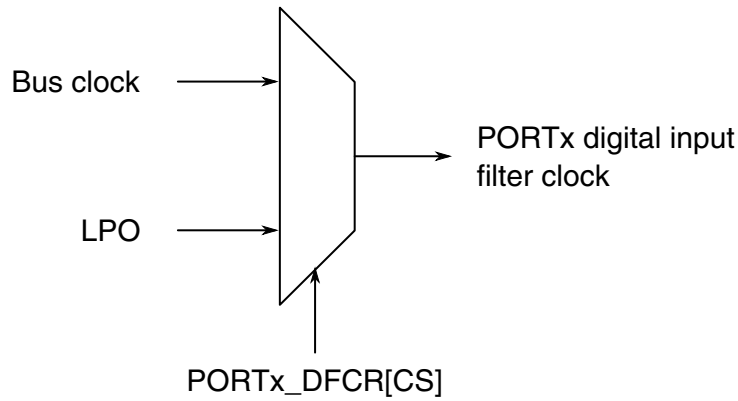

Figure 5-4. PORTx digital input filter clock generation

5.7.5 LPTMR clocking

The prescaler and glitch filters in each of the LPTMR_x modules can be clocked as shown in the following figure.

NOTE

The chosen clock must remain enabled if the LPTMR_x is to continue operating in all required low-power modes.

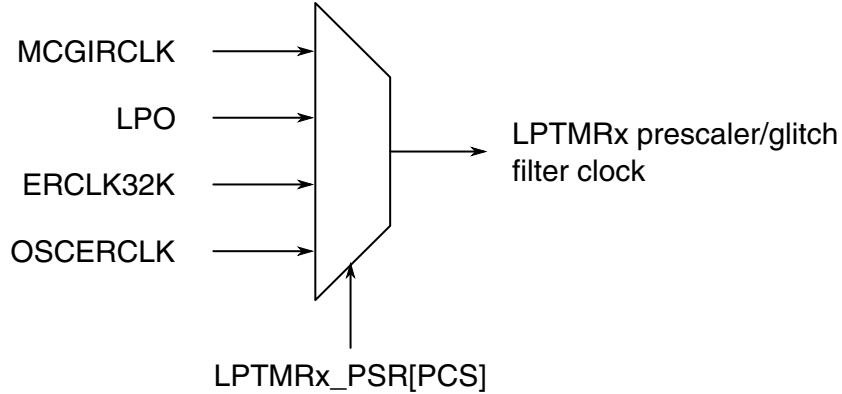

Figure 5-5. LPTMRx prescaler/glitch filter clock generation

5.7.6 USB FS OTG Controller clocking

The USB FS OTG controller is a bus master attached to the crossbar switch. As such, its clock is connected to the system clock.

NOTE

For the USB FS OTG controller to operate, the minimum system clock frequency is 20 MHz.

The USB OTG controller also requires a 48 MHz clock. The clock source options are shown below.

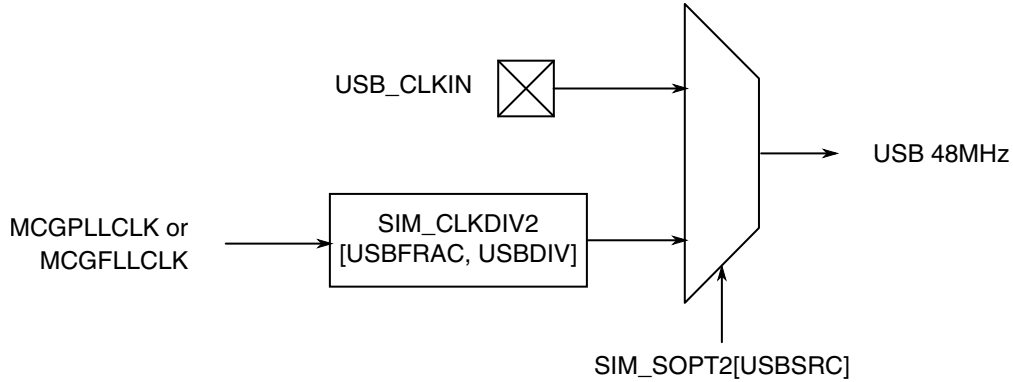

Figure 5-6. USB 48 MHz clock source

5.7.7 FlexCAN clocking

The clock for the FlexCAN's protocol engine can be selected as shown in the following figure.

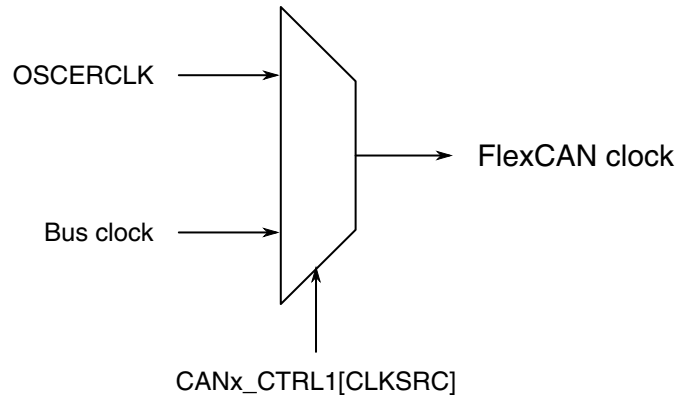

Figure 5-7. FlexCAN clock generation

5.7.8 UART clocking

UART0 and UART1 modules operate from the core/system clock, which provides higher performance level for these modules. All other UART modules operate from the bus clock.

5.7.9 SDHC clocking

The SDHC module has four possible clock sources for the external clock source, as shown in the following figure.

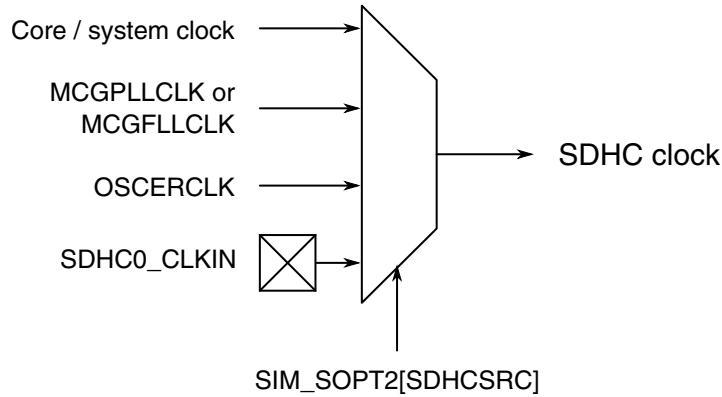

Figure 5-8. SDHC clock generation

5.7.10 I²S clocking

In addition to the bus clock, the I²S has a clock source for master clock generation. The maximum frequency of this clock is 50 MHz. The master clock source can be derived from several sources, as shown in the following figure.

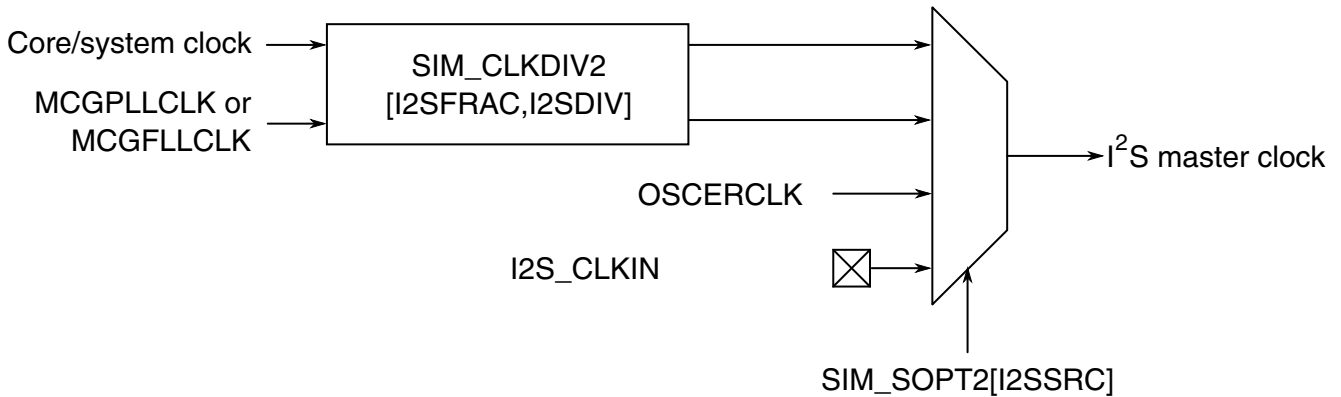

Figure 5-9. I²S baud clock generation

5.7.11 TSI clocking

In active mode, the TSI can be clocked as shown in the following figure.

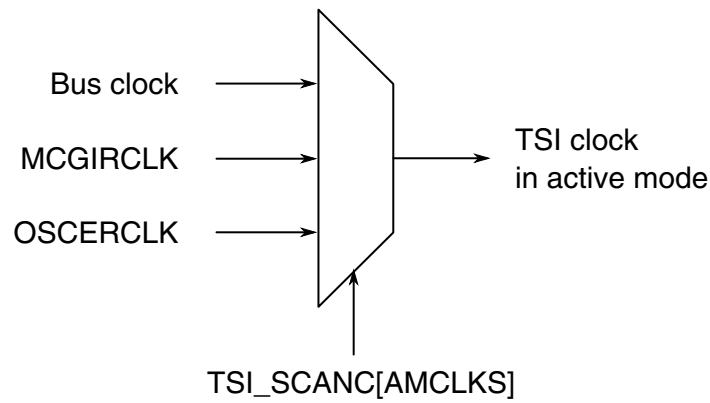

Figure 5-10. TSI clock generation

In low-power mode, the TSI can be clocked as shown in the following figure.

NOTE

In the TSI chapter, these two clocks are referred to as LPOCLK and VLPOSCCLK.

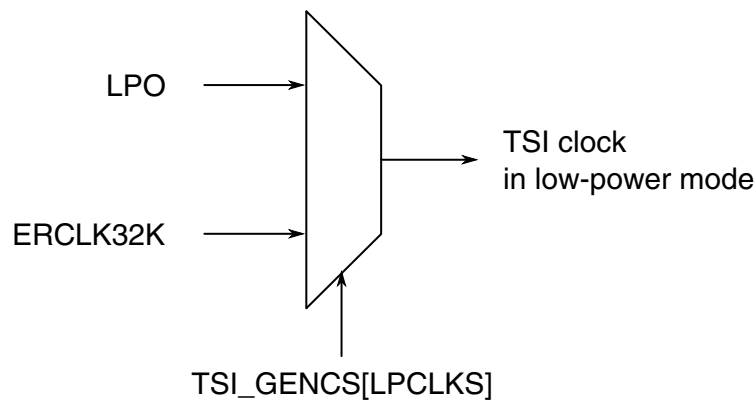

Figure 5-11. TSI low-power clock generation



Chapter 6

Reset and Boot

6.1 Introduction

The following reset sources are supported in this MCU:

Table 6-1. Reset sources

Reset sources	Description
POR reset	<ul style="list-style-type: none"> Power-on reset (POR)
System resets	<ul style="list-style-type: none"> External pin reset (PIN) Low-voltage detect (LVD) Computer operating properly (COP) watchdog reset Low leakage wakeup (LLWU) reset Multipurpose clock generator loss of clock (LOC) reset Software reset (SW) Lockup reset (LOCKUP) EzPort reset MDM DAP system reset
Debug reset	<ul style="list-style-type: none"> JTAG reset nTRST reset

Each of the system reset sources, with the exception of the EzPort and MDM-AP reset, has an associated bit in the system reset status registers (SRSH and SRSL). See the [Mode controller](#) for more details.

The MCU exits reset in functional mode that is controlled by $\overline{\text{EZP_CS}}$ pin to select between the single chip (default) or serial flash programming (EzPort) modes. See [Boot options](#) for more details.

6.2 Reset

This section discusses basic reset mechanisms and sources. Some modules that cause resets can be configured to cause interrupts instead. Consult the individual peripheral chapters for more information.

6.2.1 Power-on reset (POR)

When power is initially applied to the MCU or when the supply voltage drops below the power-on reset re-arm voltage level (V_{POR}), the POR circuit causes a POR reset condition.

As the supply voltage rises, the LVD circuit holds the MCU in reset until the supply has risen above the LVD low threshold (V_{LVDL}). The POR and LVD bits in SRSL register are set following a POR.

6.2.2 System resets

Resetting the MCU provides a way to start processing from a known set of initial conditions. System reset begins with the on-chip regulator in full regulation and system clocking generation from an internal reference. When the processor exits reset, it performs the following:

- Reads the start SP (SP_main) from vector-table offset 0
- Reads the start PC from vector-table offset 4
- LR is set to 0xFFFF_FFFF

The on-chip peripheral modules are disabled and the non-analog I/O pins are initially configured as disabled. The pins with analog functions assigned to them default to their analog function after reset.

During and following a reset, the JTAG pins have their associated input pins configured as:

- TDI in pull-up (PU)
- TCK in pull-down (PD)
- TMS in PU

and associated output pin configured as:

- TDO with no pull-down or pull-up

Note that the nTRST signal is initially configured as disabled, however once configured to its JTAG functionality its associated input pin is configured as:

- nTRST in PU

6.2.2.1 External pin reset (PIN)

On this device, $\overline{\text{RESET}}$ is a dedicated pin. This pin is open drain and has an internal pullup device. Asserting $\overline{\text{RESET}}$ wakes the device from any mode. During a pin reset, the SRSL[PIN] bit is set.

6.2.2.1.1 Reset pin filter

The $\overline{\text{RESET}}$ pin supports digital filtering in all modes of operation. For LLS and VLLSx modes, the LLWU provides an optional fixed digital filter running off the 1 kHz LPO clock. See the LLWU chapter for operation of this filter. During non-low leakage operation, there are two clock options for the $\overline{\text{RESET}}$ pin filter – the 1kHz LPO clock and the bus clock.

This $\overline{\text{RESET}}$ pin filter implemented in SIM logic includes a separate filter for each clock source. In Stop and VLPS operation this logic either switches to bypass operation or has continued filtering operation depending on the filtering mode selected.

There are several modes defined – See the SOPT6 register description in module for more details. SOPT6[RSTFLTEN[2:0]] and SOPT6[RSTFLTSEL[4:0]] fields control the desired functionality. Both filters are reset on POR, LVD, and wakeup from VLLS. The reset value for each filter defaults to off (non-detect).

The LPO filter is simple with a fixed filter value count of 3. There is also a synchronizer on the input signal that results in an associated latency (2 cycles). As such, it takes 5 cycles to complete a transition from low-to-high or high-to-low. The LPO Filter initializes to off (logic 1) when the LPO filter is not enabled.

The Bus Filter initializes to off (logic 1) when the Bus Filter not enabled. When the Bus Filter is enabled, the number of counts is controlled by SOPT6[RSTFLTSEL[4:0]].

6.2.2.2 Low-voltage detect (LVD) reset

This device includes a system to protect against low voltage conditions to protect memory contents and control MCU system states during supply voltage variations. The system is comprised of a power-on reset (POR) circuit and a low-voltage detect (LVD) circuit with a user-selectable trip voltage, either high (V_{LVDH}) or low (V_{LVDL}). The trip voltage is selected by the LVDSC1[LVDV] bits. The LVD system is always enabled in normal run, wait, and stop modes. The LVD system is disabled in VLPx, LLSx, and VLLSx modes. Refer to Power Management Controller (PMC) chapter for more details.

The LVD can be configured to generate a reset upon detection of a low voltage condition by setting LVDSC1[LVDRE]. After an LVD reset has occurred, the LVD system holds the MCU in reset until the supply voltage rises above the low voltage detection threshold.

The SRSL[LVD] bit is set following an LVD reset or POR.

6.2.2.3 Computer operating properly (COP) watchdog reset

The watchdog timer monitors the operation of the system by expecting periodic communication from the software, generally known as servicing (or refreshing) the watchdog. If this periodic refreshing does not occur, the watchdog issues a system reset. The COP reset causes the SRSL[COP] bit to set.

6.2.2.4 Low leakage wakeup (LLWU) reset

The LLWU allows up to 16 external pins, the $\overline{\text{RESET}}$ pin, and up to seven internal peripherals to wake the MCU from LLS and VLLSx power modes. The LLWU module is only functional in LLS and VLLSx power modes. In both these modes, LLS mode exits via $\overline{\text{RESET}}$ pin and any VLLS mode exits via a wakeup or reset event, the SRSL[WAKEUP] bit in mode controller module is set indicating the low leakage mode was active prior to the last system reset flow. Using the $\overline{\text{RESET}}$ pin to trigger an exit from LLS or VLLS results in the SRSL[PIN] bit being set as well. Refer to the mode controller chapter for more details.

After a system reset, the LLWU retains the flags to indicate the source of the last wakeup until the user clears them.

NOTE

Pin wakeup and error condition flags are cleared in the LLWU and module wakeup flags are required to be cleared in the peripheral module. Refer to the individual peripheral specifications for more information.

6.2.2.5 Multipurpose clock generator loss-of-clock (LOC) reset

The MCG includes a clock monitor. The clock monitor resets the device when the following conditions are met:

- The clock monitor is enabled (MCG_C6[CME] = 1)
- The MCG's external reference clock falls outside of the expected frequency range, depending on the MCG_C2[RANGE] bit

The MC_SRSL[LOC] bit is set to indicate the error.

6.2.2.6 Software reset (SW)

The SYSRESETREQ bit in the NVIC application interrupt and reset control register can be set to force a software reset on the device. (See ARM's NVIC documentation for the full description of the register fields, especially the VECTKEY field requirements.) Setting SYSRESETREQ generates a software reset request. This reset forces a system reset of all major components except for the debug module. A software reset causes SRSH[SW] bit to set.

6.2.2.7 Lockup reset (LOCKUP)

The LOCKUP gives immediate indication of seriously errant kernel software. This is the result of the core being locked because of an unrecoverable exception following the activation of the processor's built in system state protection hardware.

The LOCKUP condition causes a system reset and also causes SRSH[LOCKUP] bit to set.

6.2.2.8 EzPort reset

The EzPort supports a system reset request via EzPort signalling. The EzPort generates a system reset request following execution of a Reset Chip (RESET) command via the EzPort interface. This method of reset allows the chip to boot from flash memory after it has been programmed by an external source. The EzPort is enabled or disabled by the EZP_CS pin.

6.2.2.9 MDM-AP system reset request

Set the system reset request bit in the MDM-AP control register to initiate a system reset. This is the primary method for resets via the JTAG interface. The system reset is held until this bit is cleared.

Set the core hold reset bit in the MDM-AP control register to hold the core in reset as the rest of the chip comes out of system reset.

6.2.3 Debug resets

The following sections detail the debug resets available on the device.

6.2.3.1 JTAG reset

The JTAG module generate a system reset when certain IR codes are selected. This functional reset is asserted when EzPort, EXTEST, HIGHZ and CLAMP instructions are active. The reset source from the JTAG module is released when any other IR code is selected. A JTAG reset causes the SRSH[JTAG] bit to set.

6.2.3.2 nTRST reset

The nTRST pin causes a reset of the JTAG logic when asserted. Asserting the nTRST pin allows the debugger to gain control of the TAP controller state machine (after exiting LLS or VLLSx) without resetting the state of the debug modules.

The nTRST pin does not cause a system reset.

6.2.3.3 Resetting the Debug subsystem

Use the CDBGRSTREQ bit within the SWJ-DP CTRL/STAT register to reset the debug modules. However, as explained below, using the CDBGRSTREQ bit does not reset all debug-related registers.

CDBGRSTREQ resets the debug-related registers within the following modules:

- SWJ-DP
- AHB-AP
- ETM
- ATB replicators
- ATB upsizers
- ATB funnels
- ETB
- TPIU
- MDM-AP (MDM control and status registers)
- MCM (ETB “Almost Full” logic)

CDBGRSTREQ does not reset the debug-related registers within the following modules:

- CM4 core (core debug registers: DHCSR, DCRSR, DCRDR, DEMCR)
- FPB

- DWT
- ITM
- NVIC
- Crossbar bus switch¹
- AHB-AP¹
- Private peripheral bus¹

6.3 Boot

This section describes the boot sequence, including sources and options.

6.3.1 Boot sources

This device only supports booting from internal flash. Any secondary boot must go through an initialization sequence in flash.

6.3.2 Boot options

The device's functional mode is controlled by the state of the EzPort chip select (EZP_CS) pin during reset.

The device can be in single chip (default) or serial flash programming mode (EzPort). While in single chip mode the device can be in run or various low power modes mentioned in [Power mode transitions](#).

Table 6-2. Mode select decoding

EzPort chip select (EZP_CS)	Description
0	Serial flash programming mode (EzPort)
1	Single chip (default)

6.3.3 FOPT boot options

The flash option register (FOPT) in flash memory module (FTFL) allows the user to customize the operation of the MCU at boot time. The register contains read-only bits that are loaded from the NVM's option byte in the flash configuration field. The user can

1. CDBGSTREQ does not affect AHB resources so that debug resources on the private peripheral bus are available during System Reset.

reprogram the option byte in flash to change the FOPT values that are used for subsequent resets. For more details on programming the option byte, refer to the flash memory chapter.

The MCU uses the FTFL_FOPT register bits to configure the device at reset as shown in the following table.

Table 6-3. Flash Option Register (FTFL_FOPT) Bit Definitions

Bit Num	Field	Value	Definition
7-2	Reserved		Reserved for future expansion.
1	EZPORT_DIS	0	EzPort operation is disabled. The device always boots to normal CPU execution and the state of EZP_CS signal during reset is ignored. This option avoids inadvertent resets into EzPort mode if the EZP_CS/NMI pin is used for its NMI function.
		1	EzPort operation is enabled. The state of EZP_CS pin during reset determines if device enters EzPort mode.
0	LPBOOT	0	Low-power boot: OUTDIVx values in SIM_CLKDIV1 register are auto-configured at reset exit for higher divide values that produce lower power consumption at reset exit. <ul style="list-style-type: none"> Core and system clock divider (OUTDIV1) and bus clock divider (OUTDIV2) are 0x7 (divide by 8) Flash clock divider (OUTDIV4) is 0xF (divide by 16)
		1	Normal boot: OUTDIVx values in SIM_CLKDIV1 register are auto-configured at reset exit for higher frequency values that produce faster operating frequencies at reset exit. <ul style="list-style-type: none"> Core and system clock divider (OUTDIV1) and bus clock divider (OUTDIV2) are 0x0 (divide by 1) Flash clock divider (OUTDIV4) is 0x1 (divide by 2)

6.3.4 Boot sequence

At power up, the on-chip regulator holds the system in a POR state until the input supply is above the POR threshold. The system continues to be held in this static state until the internally regulated supplies have reached a safe operating voltage as determined by the LVD. The Mode Controller reset logic then controls a sequence to exit reset.

1. A system reset is held on internal logic, the $\overline{\text{RESET}}$ pin is driven out low, and the MCG is enabled in its default clocking mode.
2. Required clocks are enabled (Core Clock, System Clock, Flash Clock, and any Bus Clocks that do not have clock gate control).
3. The system reset on internal logic continues to be held, but the Flash Controller is released from reset and begins initialization operation while the Mode Control logic continues to drive the $\overline{\text{RESET}}$ pin out low for a count of ~128 Bus Clock cycles.

4. The $\overline{\text{RESET}}$ pin is released, but the system reset of internal logic continues to be held until the Flash Controller finishes initialization. EzPort mode is selected instead of the normal CPU execution if $\overline{\text{EZP_CS}}$ is low when the internal reset is deasserted. EzPort mode can be disabled by programming `FTFL_FOPT[EZPORT_DIS]`. Note: If recovering from VLLS1, 2, or 3 with the LLWU_P3 wakeup pin (PTA4/FTM0_CH1/ $\overline{\text{NMI}}/\overline{\text{EZP_CS}}$), use rising-edge wakeup in the LLWU or disable EzPort mode to ensure normal recovery.
5. When Flash Initialization completes, the $\overline{\text{RESET}}$ pin is observed. If $\overline{\text{RESET}}$ continues to be asserted (an indication of a slow rise time on the $\overline{\text{RESET}}$ pin or external drive in low), the system continues to be held in reset. Once the $\overline{\text{RESET}}$ pin is detected high, the system is released from reset.
6. At release of system reset, clocking is switched to a slow clock if `FTFL_FOPT[LPBOOT]` is configured for Low Power Boot
7. When the system exits reset, the processor sets up the stack, program counter (PC), and link register (LR). The processor reads the start SP (`SP_main`) from vector-table offset 0. The core reads the start PC from vector-table offset 4. LR is set to `0xFFFF_FFFF`. The CPU begins execution at the PC location. EzPort mode is entered instead of the normal CPU execution if Ezport mode was latched during the sequence.

Subsequent system resets follow this reset flow beginning with the step where system clocks are enabled.

Chapter 7

Power Management

7.1 Introduction

This chapter describes the various chip power modes and functionality of the individual modules in these modes.

7.2 Power modes

The power management controller (PMC) provides multiple power options to allow the user to optimize power consumption for the level of functionality needed.

Depending on the stop requirements of the user application, a variety of stop modes are available that provide state retention, partial power down or full power down of certain logic and/or memory. I/O states are held in all modes of operation. The following table compares the various power modes available.

For each run mode there is a corresponding wait and stop mode. Wait modes are similar to ARM sleep modes. Stop modes (VLPS, STOP) are similar to ARM sleep deep mode. The very low power run (VLPR) operating mode can drastically reduce runtime power when the maximum bus frequency is not required to handle the application needs.

The three primary modes of operation are run, wait and stop. The WFI instruction invokes both wait and stop modes for the chip. The primary modes are augmented in a number of ways to provide lower power based on application needs.

Table 7-1. Chip power modes

Chip mode	Description	Core mode	Normal recovery method
Normal run	Allows maximum performance of chip. Default mode out of reset; on-chip voltage regulator is on.	Run	-

Table continues on the next page...

Table 7-1. Chip power modes (continued)

Chip mode	Description	Core mode	Normal recovery method
Normal Wait - via WFI	Allows peripherals to function while the core is in sleep mode, reducing power. NVIC remains sensitive to interrupts; peripherals continue to be clocked.	Sleep	Interrupt
Normal Stop - via WFI	Places chip in static state. Lowest power mode that retains all registers while maintaining LVD protection. NVIC is disabled; AWIC is used to wake up from interrupt; peripheral clocks are stopped.	Sleep Deep	Interrupt
VLPR (Very Low Power Run)	On-chip voltage regulator is in a low power mode that supplies only enough power to run the chip at a reduced frequency. Reduced frequency Flash access mode (1 MHz); LVD off; internal oscillator provides a low power 2 MHz source for the core, the bus and the peripheral clocks.	Run	Interrupt
VLPW (Very Low Power Wait) -via WFI	Same as VLPR but with the core in sleep mode to further reduce power; NVIC remains sensitive to interrupts (FCLK = ON). On-chip voltage regulator is in a low power mode that supplies only enough power to run the chip at a reduced frequency.	Sleep	Interrupt
VLPS (Very Low Power Stop)-via WFI	Places chip in static state with LVD operation off. Lowest power mode with ADC and pin interrupts functional. Peripheral clocks are stopped, but LPTimer, RTC, CMP, TSI, DAC can be used. NVIC is disabled (FCLK = OFF); AWIC is used to wake up from interrupt. On-chip voltage regulator is in a low power mode that supplies only enough power to run the chip at a reduced frequency. All SRAM is operating (content retained and I/O states held).	Sleep Deep	Interrupt
LLS (Low Leakage Stop)	State retention power mode. Most peripherals are in state retention mode (with clocks stopped), but LLWU, LPTimer, RTC, CMP, TSI, DAC can be used. NVIC is disabled; LLWU is used to wake up. NOTE: The LLWU interrupt must not be masked by the interrupt controller to avoid a scenario where the system does not fully exit stop mode on an LLS recovery. All SRAM is operating (content retained and I/O states held).	Sleep Deep	Wakeup Interrupt ¹
VLLS3 (Very Low Leakage Stop3)	Most peripherals are disabled (with clocks stopped), but LLWU, LPTimer, RTC, CMP, TSI, DAC can be used. NVIC is disabled; LLWU is used to wake up. SRAM_U and SRAM_L remain powered on (content retained and I/O states held).	Sleep Deep	Wakeup Reset ²
VLLS2 (Very Low Leakage Stop2)	Most peripherals are disabled (with clocks stopped), but LLWU, LPTimer, RTC, CMP, TSI, DAC can be used. NVIC is disabled; LLWU is used to wake up. SRAM_L is powered off. A portion of SRAM_U remains powered on (content retained and I/O states held).	Sleep Deep	Wakeup Reset ²
VLLS1 (Very Low Leakage Stop1)	Most peripherals are disabled (with clocks stopped), but LLWU, LPTimer, RTC, CMP, TSI, DAC can be used. NVIC is disabled; LLWU is used to wake up. All of SRAM_U and SRAM_L are powered off. The 32-byte system register file and the 32-byte VBAT register file remain powered for customer-critical data.	Sleep Deep	Wakeup Reset ²

Table continues on the next page...

Table 7-1. Chip power modes (continued)

Chip mode	Description	Core mode	Normal recovery method
BAT (backup battery only)	The chip is powered down except for the VBAT supply. The RTC and the 32-byte VBAT register file for customer-critical data remain powered.	Off	Power-up Sequence

1. Resumes normal run mode operation by executing the LLWU interrupt service routine.
2. Follows the reset flow with the LLWU interrupt flag set for the NVIC.

7.3 Entering and exiting power modes

The WFI instruction invokes wait and stop modes for the chip. The processor exits the low-power mode via an interrupt. The [Nested Vectored Interrupt Controller \(NVIC\)](#) describes interrupt operation and what peripherals can cause interrupts.

NOTE

The WFE instruction can have the side effect of entering a low-power mode, but that is not its intended usage. See ARM documentation for more on the WFE instruction.

Recovery from VLLSx is through the wake-up Reset event. The chip wake-ups from VLLSx by means of reset, an enabled pin or enabled module. See the table "LLWU inputs" in the LLWU configuration section for a list of the sources.

The wake-up flow from VLLSx is through reset. The wakeup bit in the SRS registers in the Mode Controller is set indicating that the chip is recovering from a low power mode. Code execution begins; however, the I/O pins are held in their pre low power mode entry states, and the system oscillator and MCG registers are reset (even if EREFSTEN had been set before entering VLLSx). Software must clear this hold by writing a 1 to the ACKISO bit in the Control and Status register in the LLWU module.

NOTE

To avoid unwanted transitions on the pins, software must re-initialize the I/O pins to their pre-low-power mode entry states *before* releasing the hold.

If the oscillator was configured to continue running during VLLSx modes, it must be re-configured before the ACKISO bit is cleared. The oscillator configuration within the MCG is cleared after VLLSx recovery and the oscillator will stop when ACKISO is cleared unless the register is re-configured.

7.4 Power mode transitions

The following figure shows the power mode transitions. Any reset always brings the chip back to the normal run state. In run, wait, and stop modes active power regulation is enabled. The VLPx modes are limited in frequency, but offer a lower power operating mode than normal modes. The LLS and VLLSx modes are the lowest power stop modes based on amount of logic or memory that is required to be retained by the application.

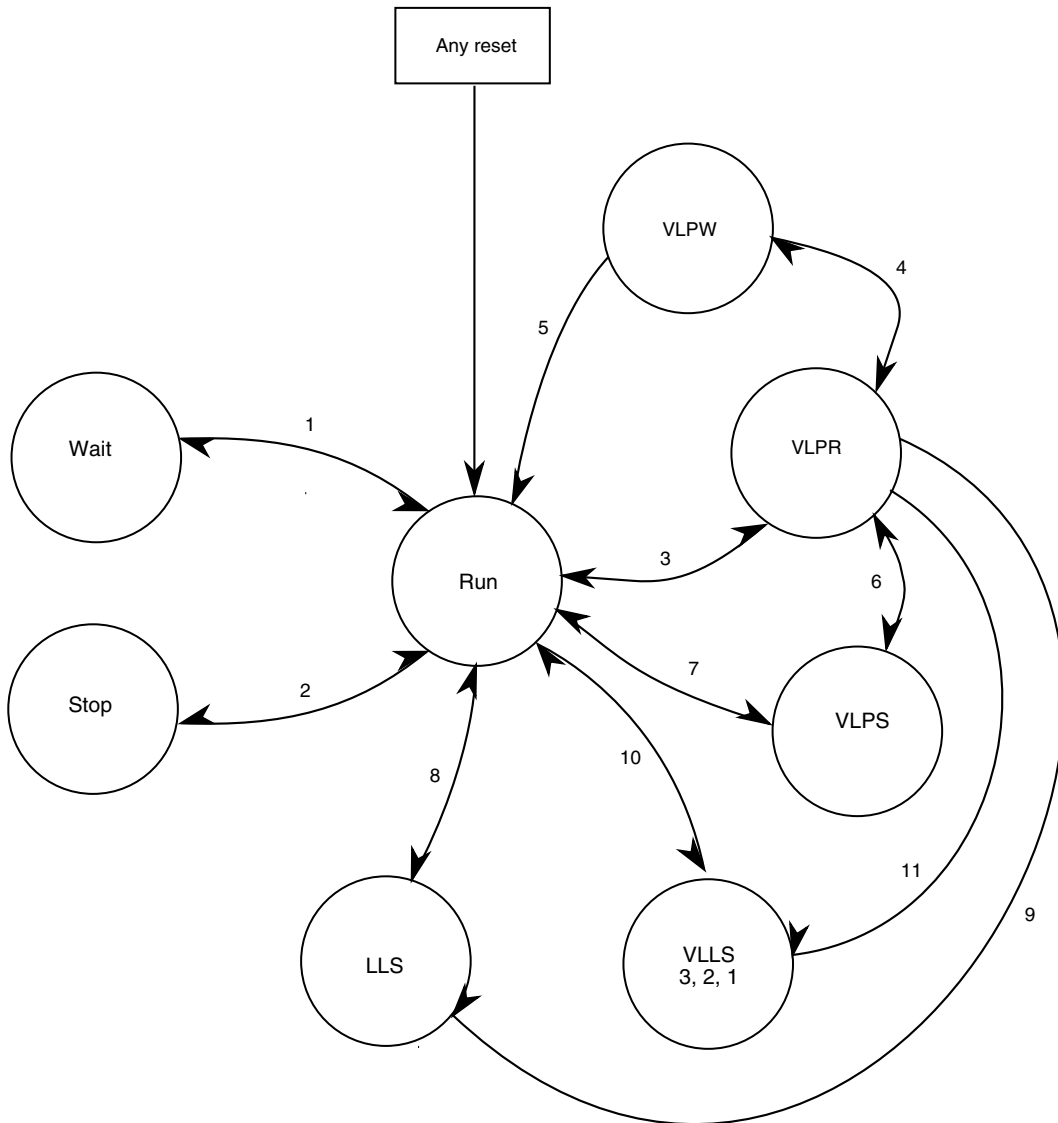

Figure 7-1. Power mode state transition diagram

7.5 Power modes shutdown sequencing

When entering stop or other low-power modes, the clocks are shut off in an orderly sequence to safely place the chip in the targeted low-power state. All low-power entry sequences are initiated by the core executing an WFI instruction. The ARM core's outputs, SLEEPDEEP and SLEEPING, trigger entry to the various low-power modes:

- System level wait and VLPW modes equate to: SLEEPING & $\overline{\text{SLEEPDEEP}}$
- All other low power modes equate to: SLEEPING & SLEEPDEEP

When entering the non-wait modes, the chip performs the following sequence:

- Shuts off Core Clock and System Clock to the ARM Cortex-M4 core immediately.
- Polls stop acknowledge indications from the non-core crossbar masters (DMA), supporting peripherals (SPI, PIT) and the Flash Controller for indications that System Clocks, Bus Clock and/or Flash Clock need to be left enabled to complete a previously initiated operation, effectively stalling entry to the targeted low power mode. When all acknowledges are detected, System Clock, Bus Clock and Flash Clock are turned off at the same time.
- MCG and Mode Controller shut off clock sources and/or the internal supplies driven from the on-chip regulator as defined for the targeted low power mode.

In wait modes, most of the system clocks are not affected by the low power mode entry. The Core Clock to the ARM Cortex-M4 core is shut off. Some modules support stop-in-wait functionality and have their clocks disabled under these configurations.

The debugger modules support a transition from stop, wait, VLPS, and VLPW back to a halted state when the debugger is enabled. This transition is initiated by setting the Debug Request bit in MDM-AP control register. As part of this transition, system clocking is re-established and is equivalent to normal run/VLPR mode clocking configuration.

7.6 Module Operation in Low Power Modes

The following table illustrates the functionality of each module while the chip is in each of the low power modes. (Debug modules are discussed separately; see [Debug in Low Power Modes](#).) Number ratings (such as 2 MHz and 1 Mbps) represent the maximum frequencies or maximum data rates per mode. Also, these terms are used:

- FF = Full functionality. In VLPR and VLPW the system frequency is limited, but if a module does not have a limitation in its functionality, it is still listed as FF.
- static = Module register states and associated memories are retained.

Module Operation in Low Power Modes

- powered = Memory is powered to retain contents.
- low power = Flash has a low power state that retains configuration registers to support faster wakeup.
- OFF = Modules are powered off; module is in reset state upon wakeup.
- wakeup = Modules can serve as a wakeup source for the chip.

Table 7-2. Module operation in low power modes

Modules	Stop	VLPR	VLPW	VLPS	LLS	VLLSx
Core modules						
NVIC	static	FF	FF	static	static	OFF
System modules						
Mode Controller	FF	FF	FF	FF	FF	FF
LLWU ¹	static	static	static	static	FF	FF
Regulator	ON	low power	low power	low power	low power	low power
LVD	ON	disabled	disabled	disabled	disabled	disabled
Brown-out Detection	ON	ON	ON	ON	ON	ON
DMA	static	FF	FF	static	static	OFF
Watchdog	FF	FF	FF	FF	static	OFF
EWM	static	FF	static	static	static	OFF
Clocks						
1kHz LPO	ON	ON	ON	ON	ON	ON
System oscillator (OSC)	OSCERCLK optional	OSCERCLK max of 4MHz crystal	OSCERCLK max of 4MHz crystal	OSCERCLK max of 4MHz crystal	limited to low range/low power	limited to low range/low power
MCG	static - MCGIRCLK optional; PLL optionally on but gated	2 MHz IRC	2 MHz IRC	static - no clock output	static - no clock output	OFF
Core clock	OFF	2 MHz max	OFF	OFF	OFF	OFF
System clock	OFF	2 MHz max	2 MHz max	OFF	OFF	OFF
Bus clock	OFF	2 MHz max	2 MHz max	OFF	OFF	OFF
Memory and memory interfaces						
Flash	powered	1 MHz max access - no pgm	low power	low power	OFF	OFF
Portion of SRAM_U ²	low power	low power	low power	low power	low power	low power in VLLS3,2
Remaining SRAM_U and all of SRAM_L	low power	low power	low power	low power	low power	low power in VLLS3

Table continues on the next page...

Table 7-2. Module operation in low power modes (continued)

Modules	Stop	VLPR	VLPW	VLPS	LLS	VLLSx
Register files ³	powered	powered	powered	powered	powered	powered
EzPort	disabled	disabled	disabled	disabled	disabled	disabled
Communication interfaces						
USB FS/LS	static	static	static	static	static	OFF
USB DCD	static	FF	FF	static	static	OFF
USB Voltage Regulator	optional	optional	optional	optional	optional	optional
UART	static, wakeup on edge	125 kbps	125 kbps	static, wakeup on edge	static	OFF
SPI	static	1 Mbps	1 Mbps	static	static	OFF
I ² C	static, address match wakeup	100 kbps	100 kbps	static, address match wakeup	static	OFF
CAN	wakeup	256 kbps	256 kbps	wakeup	static	OFF
I ² S	FF with external clock ⁴	FF	FF	FF with external clock ⁴	static	OFF
SDHC	wakeup	FF	FF	wakeup	static	OFF
Security						
CRC	static	FF	FF	static	static	OFF
Drylce ³	FF	FF	FF	FF	FF	FF
Timers						
FTM	static	FF	FF	static	static	OFF
PIT	static	FF	FF	static	static	OFF
PDB	static	FF	FF	static	static	OFF
LPTMR	FF	FF	FF	FF	FF	FF
RTC - 32kHz OSC ³	FF	FF	FF	FF	FF	FF
CMT	static	FF	FF	static	static	OFF
Analog						
16-bit ADC	ADC internal clock only	FF	FF	ADC internal clock only	static	OFF
CMP ⁵	HS or LS compare	FF	FF	HS or LS compare	LS compare	LS compare
6-bit DAC	static	FF	FF	static	static	static
VREF	FF	FF	FF	FF	static	OFF
12-bit DAC	static	FF	FF	static	static	static
Human-machine interfaces						
GPIO	wakeup	FF	FF	wakeup	static, pins latched	OFF, pins latched

Table continues on the next page...

Table 7-2. Module operation in low power modes (continued)

Modules	Stop	VLPR	VLPW	VLPS	LLS	VLLSx
Segment LCD	FF	FF	FF	FF	FF ⁶	FF ⁶
TSI	wakeup	FF	FF	wakeup	wakeup ⁷	wakeup ⁷

1. Using the LLWU module, the external pins available for this chip do not require the associated peripheral function to be enabled. It only requires the function controlling the pin (GPIO or peripheral) to be configured as an input to allow a transition to occur to the LLWU.
2. A 4KB portion of SRAM_U block is left powered on in low power mode VLLS2.
3. These components remain powered in BAT power mode.
4. Use an externally generated bit clock or an externally generated audio master clock (including EXTAL).
5. CMP in stop or VLPS supports high speed or low speed external pin to pin or external pin to DAC compares. CMP in LLS or VLLSx only supports low speed external pin to pin or external pin to DAC compares. Windowed, sampled & filtered modes of operation are not available while in stop, VLPS, LLS, or VLLSx modes.
6. End of Frame wakeup not supported in LLS and VLLSx.
7. TSI wakeup from LLS and VLLSx modes is limited to a single selectable pin.

7.7 Clock Gating

To conserve power, the clocks to most modules can be turned off using the SCGCx registers in the SIM module. These bits are cleared after any reset, which disables the clock to the corresponding module. Prior to initializing a module, set the corresponding bit in the SCGCx register to enable the clock. Before turning off the clock, make sure to disable the module. For more details, refer to the clock distribution and SIM chapters.

Chapter 8

Security

8.1 Introduction

This device implements security based on the mode selected from the flash module. The following sections provide an overview of flash security and details the effects of security on non-flash modules.

8.2 Flash Security

The flash module provides security information to the MCU based on the state held by the FSEC[SEC] bits. The MCU, in turn, confirms the security request and limits access to flash resources. During reset, the flash module initializes the FSEC register using data read from the security byte of the flash configuration field.

NOTE

The security features apply only to external accesses: debug and EzPort. CPU accesses to the flash are not affected by the status of FSEC.

In the unsecured state all flash commands are available to the programming interfaces (JTAG and EzPort), as well as user code execution of Flash Controller commands. When the flash is secured (FSEC[SEC] = 00, 01, or 11), programmer interfaces are only allowed to launch mass erase operations and have no access to memory locations.

Further information regarding the flash security options and enabling/disabling flash security is available in the [Flash Memory Module](#).

8.3 Security Interactions with other Modules

The flash security settings are used by the SoC to determine what resources are available. The following sections describe the interactions between modules and the flash security settings or the impact that the flash security has on non-flash modules.

8.3.1 Security Interactions with EzPort

When flash security is active the MCU can still boot in EzPort mode. The EzPort holds the flash logic in NVM special mode and thus limits flash operation when flash security is active. While in EzPort mode and security is active, flash bulk erase (BE) can still be executed. The write FCCOB registers (WRFCCOB) command is limited to the mass erase (Erase All Blocks) and verify all 1s (Read 1s All Blocks) commands. Read accesses to internal memories via the EzPort are blocked when security is enabled.

The mass erase can be used to disable flash security, but all of the flash contents are lost in the process. A mass erase via the EzPort is allowed even when some memory locations are protected.

When mass erase has been disabled, mass erase via the EzPort is blocked and cannot be defeated.

8.3.2 Security Interactions with Debug

When flash security is active the JTAG port cannot access the memory resources of the MCU. Boundary scan chain operations work, but debugging capabilities are disabled so that the debug port cannot read flash contents.

Although most debug functions are disabled, the debugger can write to the Flash Mass Erase in Progress bit in the MDM-AP Control register to trigger a mass erase (Erase All Blocks) command. A mass erase via the debugger is allowed even when some memory locations are protected.

When mass erase is disabled, mass erase via the debugger is blocked.

Chapter 9

Debug

9.1 Introduction

This device's debug is based on the ARM coresight architecture and is configured in each device to provide the maximum flexibility as allowed by the restrictions of the pinout and other available resources.

Four debug interfaces are supported:

- IEEE 1149.1 JTAG
- IEEE 1149.7 JTAG (cJTAG)
- Serial Wire Debug (SWD)
- ARM Real-Time Trace Interface

The basic Cortex-M4 debug architecture is very flexible. The following diagram shows the topology of the core debug architecture and its components.

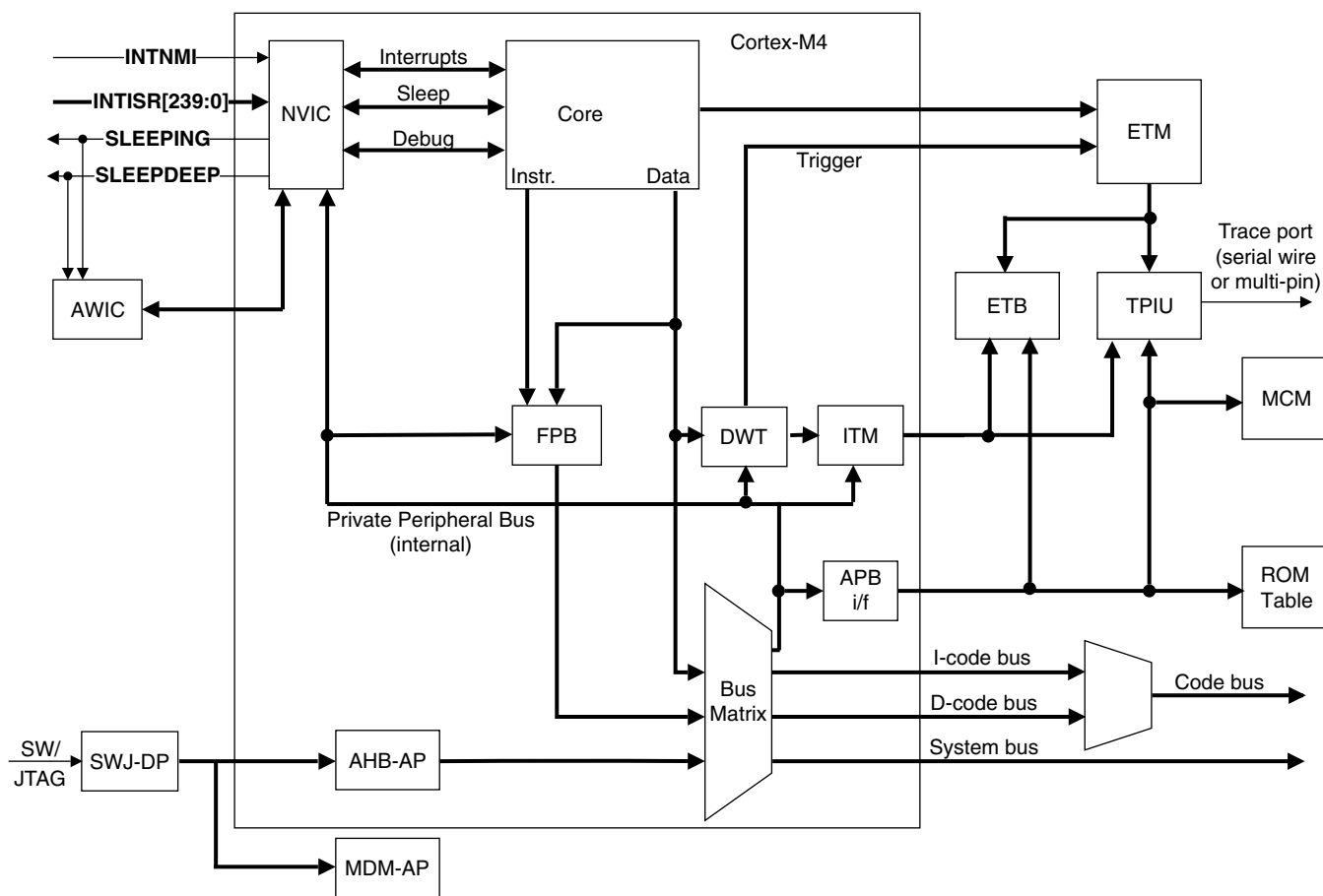

Figure 9-1. Cortex-M4 Debug Topology

The following table presents a brief description of each one of the debug components.

Table 9-1. Debug Components Description

Module	Description
SWJ-DP+ cJTAG	Modified Debug Port with support for SWD, JTAG, cJTAG
AHB-AP	AHB Master Interface from JTAG to debug module and SOC system memory maps
JTAG-AP	Bridge to DFT/BIST resources.
ROM Table	Identifies which debug IP is available.
Core Debug	Singlestep, Register Access, Run, Core Status
CoreSight Trace Funnel (not shown in figure)	The CSTF combines multiple trace streams onto a single ATB bus.
CoreSight Trace Replicator (not shown in figure)	The ATB replicator enables two trace sinks to be wired together and operate from the same incoming trace stream.
ETM (Embedded Trace Macrocell)	ETMv3.5 Architecture
CoreSight ETB (Embedded Trace Buffer)	Memory mapped buffer used to store trace data.
ITM	S/W Instrumentation Messaging + Simple Data Trace Messaging + Watchpoint Messaging

Table continues on the next page...

Table 9-1. Debug Components Description (continued)

Module	Description
DWT (Data and Address Watchpoints)	4 data and address watchpoints (configurable for less, but 4 seems to be accepted)
FPB (Flash Patch and Breakpoints)	<p>The FPB implements hardware breakpoints and patches code and data from code space to system space.</p> <p>The FPB unit contains two literal comparators for matching against literal loads from Code space, and remapping to a corresponding area in System space.</p> <p>The FPB also contains six instruction comparators for matching against instruction fetches from Code space, and remapping to a corresponding area in System space. Alternatively, the six instruction comparators can individually configure the comparators to return a Breakpoint Instruction (BKPT) to the processor core on a match, so providing hardware breakpoint capability.</p>
TPIU (Trace Port Interface Unit)	<p>Synchronous Mode (5-pin) = TRACE_D[3:0] + TRACE_CLKOUT</p> <p>Synchronous Mode (3-pin) = TRACE_D[1:0] + TRACE_CLKOUT</p> <p>Asynchronous Mode (1-pin) = TRACE_SWO (available on JTAG_TDO)</p>
MCM (Miscellaneous Control Module)	The MCM provides miscellaneous control functions including control of the ETB and trace path switching.

9.1.1 References

For more information on ARM debug components, see these documents:

- ARMv7-M Architecture Reference Manual
- ARM Debug Interface v5.1
- ARM CoreSight Architecture Specification
- ARM ETM Architecture Specification v3.5

9.2 The Debug Port

The configuration of the cJTAG module, JTAG controller, and debug port is illustrated in the following figure:

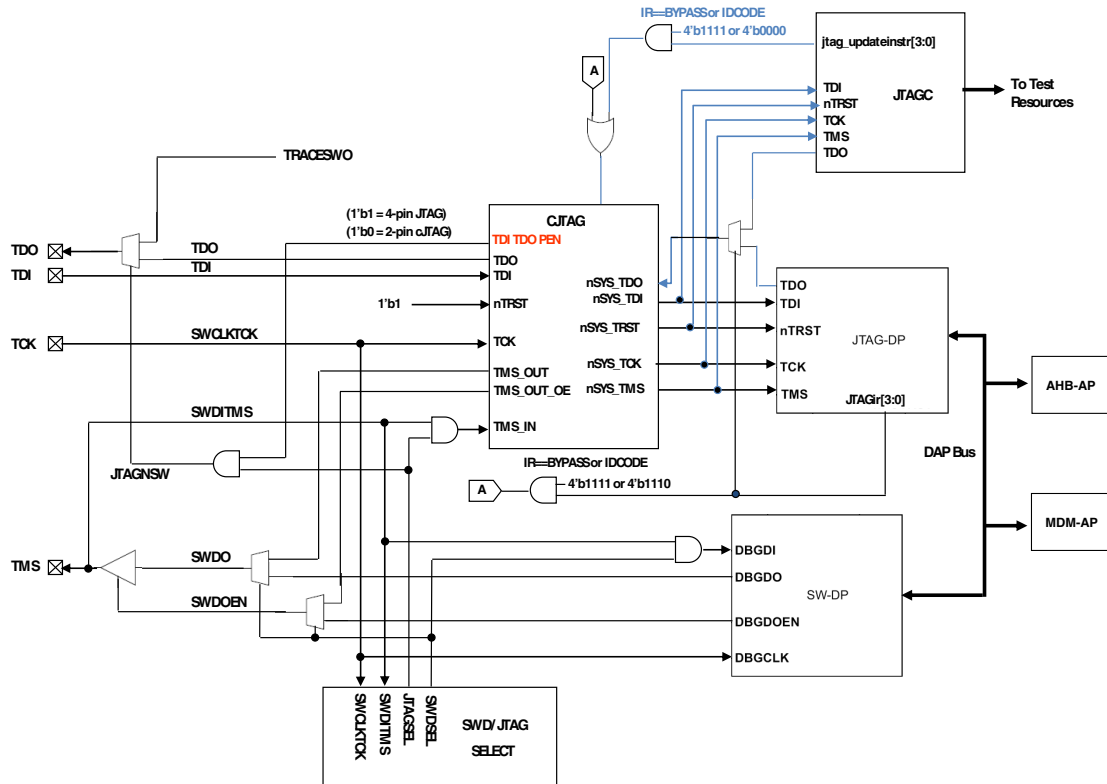

Figure 9-2. Modified Debug Port

The debug port comes out of reset in standard JTAG mode and is switched into either cJTAG or SWD mode by the following sequences. Once the mode has been changed, unused debug pins can be reassigned to any of their alternative muxed functions.

9.2.1 JTAG-to-SWD change sequence

1. Send more than 50 TCK cycles with TMS (SWDIO) = 1
2. Send the 16-bit sequence on TMS (SWDIO) = 0111_1001_1110_0111 (MSB transmitted first)
3. Send more than 50 TCK cycles with TMS (SWDIO) = 1

NOTE

See the ARM documentation for the CoreSight DAP Lite for restrictions.

9.2.2 JTAG-to-cJTAG change sequence

1. Reset the debug port

2. Set the control level to 2 via zero-bit scans
3. Execute the Store Format (STFMT) command (00011) to set the scan format register to 1149.7 scan format

9.3 Debug Port Pin Descriptions

The debug port pins default after POR to their JTAG functionality with the exception of JTAG_TRST_b and can be later reassigned to their alternate functionalities. In cJTAG and SWD modes JTAG_TDI and JTAG_TRST_b can be configured to alternate GPIO functions.

Table 9-2. Debug port pins

Pin Name	JTAG Debug Port		cJTAG Debug Port		SWD Debug Port		Internal Pull-up/Down
	Type	Description	Type	Description	Type	Description	
JTAG_TMS/ SWD_DIO	I/O	JTAG Test Mode Selection	I/O	cJTAG Data	I/O	Serial Wire Data	Pull-up
JTAG_TCLK/ SWD_CLK	I	JTAG Test Clock	I	cJTAG Clock	I	Serial Wire Clock	Pull-down
JTAG_TDI	I	JTAG Test Data Input	-	-	-	-	Pull-up
JTAG_TDO/ TRACE_SW O	O	JTAG Test Data Output	O	Trace output over a single pin	O	Trace output over a single pin	N/C
JTAG_TRST_b	I	JTAG Reset	I	cJTAG Reset	-	-	Pull-up

9.4 System TAP connection

The system JTAG controller is connected in parallel to the ARM TAP controller. The system JTAG controller IR codes overlay the ARM JTAG controller IR codes without conflict. Refer to the IR codes table for a list of the available IR codes. The output of the TAPs (TDO) are muxed based on the IR code which is selected. This design is fully JTAG compliant and appears to the JTAG chain as a single TAP. At power on reset, ARM's IDCODE (IR=4'b1110) is selected.

9.4.1 IR Codes

Table 9-3. JTAG Instructions

Instruction	Code[3:0]	Instruction Summary
IDCODE	0000	Selects device identification register for shift
SAMPLE/PRELOAD	0010	Selects boundary scan register for shifting, sampling, and preloading without disturbing functional operation
SAMPLE	0011	Selects boundary scan register for shifting and sampling without disturbing functional operation
EXTEST	0100	Selects boundary scan register while applying preloaded values to output pins and asserting functional reset
HIGHZ	1001	Selects bypass register while three-stating all output pins and asserting functional reset
CLAMP	1100	Selects bypass register while applying preloaded values to output pins and asserting functional reset
EZPORT	1101	Enables the EZPORT function for the SoC and asserts functional reset.
ARM_IDCODE	1110	ARM JTAG-DP Instruction
BYPASS	1111	Selects bypass register for data operations
Factory debug reserved	0101, 0110, 0111	Intended for factory debug only
ARM JTAG-DP Reserved	1000, 1010, 1011, 1110	These instructions will go the ARM JTAG-DP controller. Please look at ARM JTAG-DP documentation for more information on these instructions.
Reserved ¹	All other opcodes	Decoded to select bypass register

1. The manufacturer reserves the right to change the decoding of reserved instruction codes in the future

9.5 JTAG status and control registers

Through the ARM Debug Access Port (DAP), the debugger has access to the status and control elements, implemented as registers on the DAP bus as shown in the following figure. These registers provide additional control and status for low power mode recovery and typical run-control scenarios. The status register bits also provide a means for the debugger to get updated status of the core without having to initiate a bus transaction across the crossbar switch, thus remaining less intrusive during a debug session.

It is important to note that these DAP control and status registers are not memory mapped within the system memory map and are only accessible via the Debug Access Port (DAP) using JTAG, cJTAG, or SWD. The MDM-AP is accessible as Debug Access Port 1 with the available registers shown in the table below.

Table 9-4. MDM-AP Register Summary

Address	Register	Description
0x0100_0000	Status	See MDM-AP Status Register
0x0100_0004	Control	See MDM-AP Control Register
0x0100_00FC	ID	Read-only identification register that always reads as 0x001C_0000

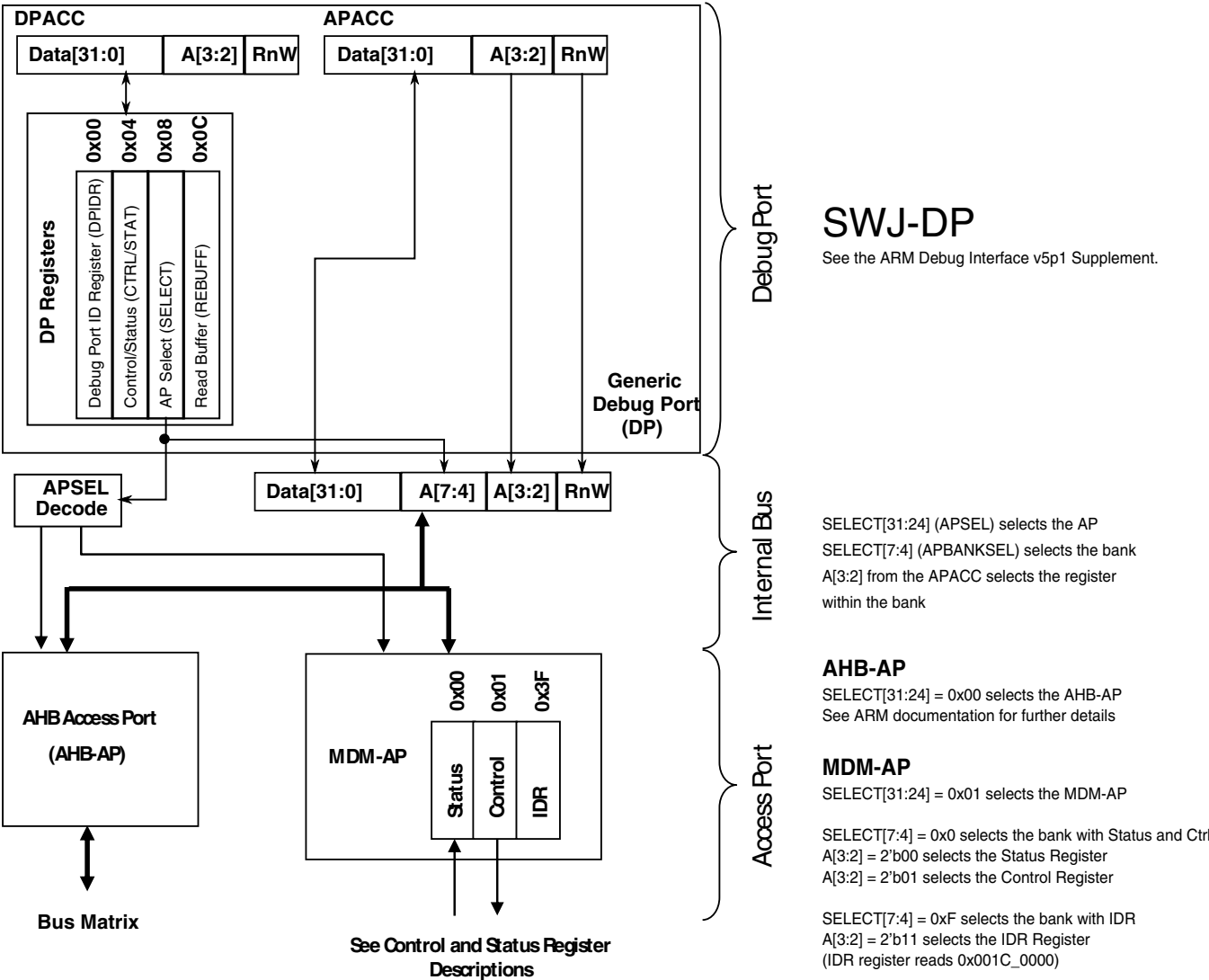

Figure 9-3. MDM AP Addressing

9.5.1 MDM-AP Control Register

Table 9-5. MDM-AP Control register assignments

Bit	Name	Secure ¹	Description
0	Flash Mass Erase in Progress	Y	Set to cause mass erase. Cleared by hardware after mass erase operation completes. When mass erase is disabled (via MEEN and SEC settings), the erase request does not occur and the Flash Mass Erase in Progress bit continues to assert until the next system reset.
1	Debug Disable	N	Set to disable debug. Clear to allow debug operation. When set it overrides the C_DEBUGEN bit within the DHCSR and force disables Debug logic.
2	Debug Request	N	Set to force the Core to halt. If the Core is in a stop or wait mode, this bit can be used to wakeup the core and transition to a halted state.
3	System Reset Request	N	Set to force a system reset. The system remains held in reset until this bit is cleared.
4	Core Hold Reset	N	Configuration bit to control Core operation at the end of system reset sequencing. 0 Normal operation - release the Core from reset along with the rest of the system at the end of system reset sequencing. 1 Suspend operation - hold the Core in reset at the end of reset sequencing. Once the system enters this suspended state, clearing this control bit immediately releases the Core from reset and CPU operation begins.
5	VLLSx Debug Request (VLLDBGREQ)	N	Set to configure the system to be held in reset after the next recovery from a VLLSx mode. This bit drives directly to the Mode Controller to control this feature. This bit holds the Core in reset when VLLSx modes are exited to allow the debugger time to re-initialize debug IP before the debug session continues. The Mode Controller captures this bit logic on entry to VLLSx modes. Upon exit from VLLSx modes, the Mode Controller holds the Core in reset at the end of system reset sequencing. The Mode Controller will hold the Core in reset until VLLDBGACK is asserted. The VLLDBGREQ bit clears automatically due to the POR reset generated as part of the VLLSx recovery.
6	VLLSx Debug Acknowledge (VLLDBGACK)	N	Set to release a Core being held in reset following a VLLSx recovery This bit is used by the debugger to release the system reset when it is being held on VLLSx mode exit. The debugger re-initializes all debug IP and then assert this control bit to allow the Mode Controller to release the Core from reset and allow CPU operation to begin. The VLLDBGACK bit is cleared by the debugger or can be left set because it clears automatically due to the POR reset generated as part of the next VLLSx recovery.

Table continues on the next page...

Table 9-5. MDM-AP Control register assignments (continued)

Bit	Name	Secure ¹	Description
7	LLS, VLLSx Status Acknowledge	N	Set this bit to acknowledge the DAP LLS and VLLS Status bits have been read. This acknowledge automatically clears the status bits. This bit is used by the debugger to clear the sticky LLS and VLLSx mode entry status bits. This bit is asserted and cleared by the debugger.
8 – 31	Reserved for future use	N	

1. Command available in secure mode

9.5.2 MDM-AP Status Register

Table 9-6. MDM-AP Status register assignments

Bit	Name	Description
0	Flash Mass Erase Acknowledge	The Flash Mass Erase Acknowledge bit is cleared after any system reset. The bit is also cleared at launch of a mass erase command due to write of Flash Mass Erase in Progress bit in MDM AP Control Register. The Flash Mass Erase Acknowledge is set after Flash control logic has started the mass erase operation. When mass erase is disabled (via MEEN and SEC settings), an erase request due to setting of Flash Mass Erase in Progress bit is not acknowledged.
1	Flash Ready	Indicate Flash has been initialized and debugger can be configured even if system is continuing to be held in reset via the debugger.
2	System Security	Indicates the security state. When secure, the debugger does not have access to the system bus or any memory mapped peripherals. This bit indicates when the part is locked and no system bus access is possible.
3	System Reset	Indicates the system reset state. 0 System is in reset 1 System is not in reset
4	Reserved	
5	Mass Erase Enable	Indicates if the MCU can be mass erased or not 0 Mass erase is disabled 1 Mass erase is enabled
6	Backdoor Access Key Enable	Indicates if the MCU has the backdoor access key enabled. 0 Disabled 1 Enabled

Table continues on the next page...

Table 9-6. MDM-AP Status register assignments (continued)

Bit	Name	Description
7	LP Enabled	Decode of LPLLSM control bits to indicate that VLPS, LLS, or VLLSx are the selected power mode the next time the ARM Core enters Deep Sleep. 0 Low Power Stop Mode is not enabled 1 Low Power Stop Mode is enabled Usage intended for debug operation in which Run to VLPS is attempted. Per debug definition, the system actually enters the Stop state. A debugger should interpret deep sleep indication (with SLEEPDEEP and SLEEPING asserted), in conjunction with this bit asserted as the debugger-VLPS status indication.
8	Very Low Power Mode	Indicates current power mode is VLPx. This bit is not 'sticky' and should always represent whether VLPx is enabled or not. This bit is used to throttle JTAG TCK frequency up/down.
9	LLS Mode Exit	This bit indicates an exit from LLS mode has occurred. The debugger will lose communication while the system is in LLS (including access to this register). Once communication is reestablished, this bit indicates that the system had been in LLS. Since the debug modules held their state during LLS, they do not need to be reconfigured. This bit is set during the LLS recovery sequence. The LLS Mode Exit bit is held until the debugger has had a chance to recognize that LLS was exited and is cleared by a write of 1 to the LLS, VLLSx Status Acknowledge bit in MDM AP Control register.
10	VLLSx Modes Exit	This bit indicates an exit from VLLSx mode has occurred. The debugger will lose communication while the system is in VLLSx (including access to this register). Once communication is reestablished, this bit indicates that the system had been in VLLSx. Since the debug modules lose their state during VLLSx modes, they need to be reconfigured. This bit is set during the VLLSx recovery sequence. The VLLSx Mode Exit bit is held until the debugger has had a chance to recognize that a VLLS mode was exited and is cleared by a write of 1 to the LLS, VLLSx Status Acknowledge bit in MDM AP Control register.
11 – 15	Reserved for future use	Always read 0.
16	Core Halted	Indicates the Core has entered debug halt mode
17	Core SLEEPDEEP	Indicates the Core has entered a low power mode
18	Core SLEEPING	SLEEPING==1 and SLEEPDEEP==0 indicates wait or VLPW mode. SLEEPING==1 and SLEEPDEEP==1 indicates stop or VLPS mode.
19 – 31	Reserved for future use	Always read 0.

9.6 Debug Resets

The debug system receives the following sources of reset:

- JTAG_TRST_b from an external signal. This signal is optional and may not be available in all packages.

- Debug reset (CDBGSTREQ bit within the SWJ-DP CTRL/STAT register) in the TCLK domain that allows the debugger to reset the debug logic.
- TRST asserted via the cJTAG escape command.
- System POR reset

Conversely the debug system is capable of generating system reset using the following mechanism:

- A system reset in the DAP control register which allows the debugger to hold the system in reset.
- SYSRESETREQ bit in the NVIC application interrupt and reset control register
- A system reset in the DAP control register which allows the debugger to hold the Core in reset.

9.7 AHB-AP

AHB-AP provides the debugger access to all memory and registers in the system, including processor registers through the NVIC. System access is independent of the processor status. AHB-AP does not do back-to-back transactions on the bus, so all transactions are non-sequential. AHB-AP can perform unaligned and bit-band transactions. AHB-AP transactions bypass the FPB, so the FPB cannot remap AHB-AP transactions. SWJ/SW-DP-initiated transaction aborts drive an AHB-AP-supported sideband signal called HABORT. This signal is driven into the Bus Matrix, which resets the Bus Matrix state, so that AHB-AP can access the Private Peripheral Bus for last ditch debugging such as read/stop/reset the core. AHB-AP transactions are little endian.

The MPU includes default settings and protections for the Region Descriptor 0 (RGD0) such that the Debugger always has access to the entire address space and those rights cannot be changed by the core or any other bus master.

For a short period at the start of a system reset event the system security status is being determined and debugger access to all AHB-AP transactions is blocked. The MDM-AP Status register is accessible and can be monitored to determine when this initial period is completed. After this initial period, if system reset is held via assertion of the RESET pin, the debugger has access via the bus matrix to the private peripheral bus to configure the debug IP even while system reset is asserted. While in system reset, access to other memory and register resources, accessed over the Crossbar Switch, is blocked.

9.8 ITM

The ITM is an application-driven trace source that supports printf style debugging to trace Operating System (OS) and application events, and emits diagnostic system information. The ITM emits trace information as packets. There are four sources that can generate packets. If multiple sources generate packets at the same time, the ITM arbitrates the order in which packets are output. The four sources in decreasing order of priority are:

1. Software trace -- Software can write directly to ITM stimulus registers. This emits packets.
2. Hardware trace -- The DWT generates these packets, and the ITM emits them.
3. Time stamping -- Timestamps are emitted relative to packets. The ITM contains a 21-bit counter to generate the timestamp. The Cortex-M4 clock or the bitclock rate of the Serial Wire Viewer (SWV) output clocks the counter.
4. Global system timestamping. Timestamps can optionally be generated using a system-wide 48-bit count value. The same count value can be used to insert timestamps in the ETM trace stream, allowing coarse-grain correlation.

9.9 Core Trace Connectivity

9.10 Embedded Trace Macrocell v3.5 (ETM)

The Cortex-M4 Embedded Trace Macrocell (ETM-M4) is a debug component that enables a debugger to reconstruct program execution. The CoreSight ETM-M4 supports only instruction trace. You can use it either with the Cortex-M4 Trace Port Interface Unit (M4-TPIU), or with the CoreSight ETB.

The main features of an ETM are:

- tracing of 16-bit and 32-bit Thumb instructions
- four EmbeddedICE watchpoint inputs
- a Trace Start/Stop block with EmbeddedICE inputs
- one reduced function counter
- two external inputs
- a 24-byte FIFO queue
- global timestamping

9.11 Coresight Embedded Trace Buffer (ETB)

The ETB provides on-chip storage of trace data using 32-bit RAM. The ETB accepts trace data from any CoreSight-compliant component trace source with an ATB master port, such as a trace source or a trace funnel. It is included in this device to remove dependencies from the trace pin pad speed, and enable low cost trace solutions. The TraceRAM size is 2 KB.

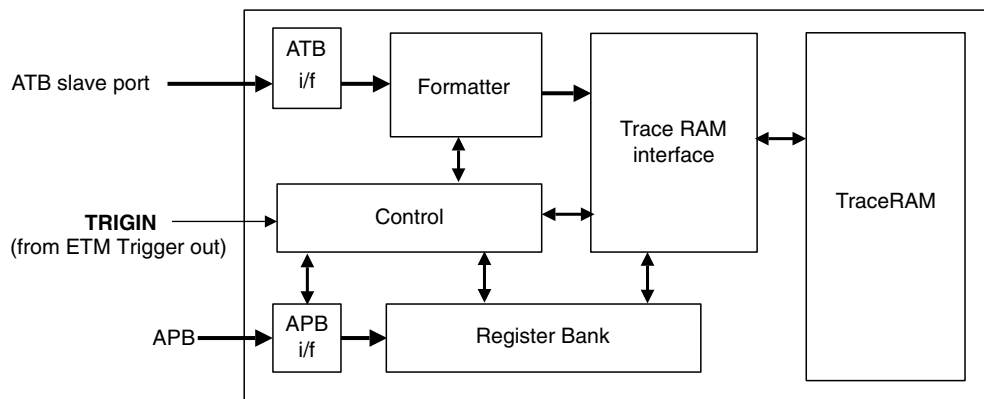

Figure 9-4. ETB Block Diagram

The ETB contains the following blocks:

- **Formatter** -- Inserts source ID signals into the data packet stream so that trace data can be re-associated with its trace source after the data is read back out of the ETB.
- **Control** -- Control registers for trace capture and flushing.
- **APB interface** -- Read, write, and data pointers provide access to ETB registers. In addition, the APB interface supports wait states through the use of a PREADYDBG signal output by the ETB. The APB interface is synchronous to the ATB domain.
- **Register bank** -- Contains the management, control, and status registers for triggers, flushing behavior, and external control.
- **Trace RAM interface** -- Controls reads and writes to the Trace RAM.

9.11.1 Performance Profiling with the ETB

To create a performance profile (e.g. gprof) for the target application, a means to collect trace over a long period of time is needed. The ETB buffer is too small to capture a meaningful profile in just one take. What is needed is to collect and concatenate data from the ETB buffer for multiple sequential runs. Using the ETB packet counter (described in [Miscellaneous Control Module \(MCM\)](#)), the trace analysis tool can capture

multiple sequential runs by executing code until the ETB is almost full, and halting or executing an interrupt handler to allow the buffer to be emptied, and then continuing executing code. The target halts or executes an interrupt handler when the buffer is almost full to empty the data and then the debugger runs the target again.

9.11.2 ETB Counter Control

The ETB packet counter is controlled by the ETB counter control register, ETB reload register, and ETB counter value register implemented in the [Miscellaneous Control Module \(MCM\)](#) accessible via the Private Peripheral Bus. Via the ETB counter control register the ETB control logic can be configured to cause an MCM Alert Interrupt, an NMI Interrupt, or cause a Debug halt when the down counter reaches 0. Other features of the ETB control logic include:

- Down counter to count as many as 512 x 32-bit packets.
- Reload request transfers reload value to counter.
- ATB valid and ready signals used to form counter decrement.
- The counter disarms itself when the count reaches 0.

9.12 TPIU

The TPIU acts as a bridge between the on-chip trace data from the Embedded Trace Macrocell (ETM) and the Instrumentation Trace Macrocell (ITM), with separate IDs, to a data stream, encapsulating IDs where required, that is then captured by a Trace Port Analyzer (TPA). The TPIU is specially designed for low-cost debug.

9.13 DWT

The DWT is a unit that performs the following debug functionality:

- It contains four comparators that you can configure as a hardware watchpoint, an ETM trigger, a PC sampler event trigger, or a data address sampler event trigger. The first comparator, DWT_COMP0, can also compare against the clock cycle counter, CYCCNT. The second comparator, DWT_COMP1, can also be used as a data comparator.
- The DWT contains counters for:
 - Clock cycles (CYCCNT)
 - Folded instructions
 - Load store unit (LSU) operations

- Sleep cycles
- CPI (all instruction cycles except for the first cycle)
- Interrupt overhead

NOTE

An event is emitted each time a counter overflows.

- The DWT can be configured to emit PC samples at defined intervals, and to emit interrupt event information.

9.14 Debug in Low Power Modes

In low power modes in which the debug modules are kept static or powered off, the debugger cannot gather any debug data for the duration of the low power mode. In the case that the debugger is held static, the debug port returns to full functionality as soon as the low power mode exits and the system returns to a state with active debug. In the case that the debugger logic is powered off, the debugger is reset on recovery and must be reconfigured once the low power mode is exited.

Power mode entry logic monitors Debug Power Up and System Power Up signals from the debug port as indications that a debugger is active. These signals can be changed in RUN, VLPR, WAIT and VLPW. If the debug signal is active and the system attempts to enter stop or VLPS, FCLK continues to run to support core register access and trace. In these modes in which FCLK is left active the debug modules have access to core registers but not to system memory resources accessed via the crossbar.

With debug enabled, transitions from Run directly to VLPS are not allowed and result in the system entering Stop mode instead. Status bits within the MDM-AP Status register can be evaluated to determine this pseudo-VLPS state. Note with the debug enabled, transitions from Run--> VLPR --> VLPS are still possible but also result in the system entering Stop mode instead.

In VLLS mode all debug modules are powered off and reset at wakeup. In LLS mode, the debug modules retain their state but no debug activity is possible.

NOTE

When using cJTAG and entering LLS mode, the cJTAG controller must be reset on exit from LLS mode.

Going into a VLLSx mode causes all the debug controls and settings to be reset. To give time to the debugger to sync up with the HW, the MDM-AP Control register can be configured hold the system in reset on recovery so that the debugger can regain control and reconfigure debug logic prior to the system exiting reset and resuming operation.

9.14.1 Debug Module State in Low Power Modes

The following table shows the state of the debug modules in low power modes. These terms are used:

- FF = Full functionality. In VLPR and VLPW the system frequency is limited, but if a module does not have a limitation in its functionality, it is still listed as FF.
- static = Module register states and associated memories are retained.
- OFF = Modules are powered off; module is in reset state upon wakeup.

Table 9-7. Debug Module State in Low Power Modes

Module	STOP	VLPR	VLPW	VLPS	LLS	VLLSx
Debug Port	FF	FF	FF	OFF	static	OFF
AHB-AP	FF	FF	FF	OFF	static	OFF
ITM	FF	FF	FF	OFF	static	OFF
ETM	FF	FF	FF	OFF	static	OFF
ETB	FF	FF	FF	OFF	static	OFF
TPIU	FF	FF	FF	OFF	static	OFF
DWT	FF	FF	FF	OFF	static	OFF

9.15 Debug & Security

When security is enabled (FSEC[SEC] != 10), the debug port capabilities are limited in order to prevent exploitation of secure data. In the secure state the debugger still has access to the MDM-AP Status Register and can determine the current security state of the device. In the case of a secure device, the debugger also has the capability of performing a mass erase operation via writes to the MDM-AP Control Register. In the case of a secure device that has mass erase disabled (FSEC[MEEN] = 10), attempts to mass erase via the debug interface are blocked.

Chapter 10

Signal Multiplexing and Signal Descriptions

10.1 Introduction

To optimize functionality in small packages, pins have several functions available via signal multiplexing. This chapter illustrates which of this device's signals are multiplexed on which external pin.

The [Port Control](#) block controls which signal is present on the external pin. Reference that chapter to find which register controls the operation of a specific pin.

10.2 Signal Multiplexing Integration

This section summarizes how the module is integrated into the device. For a comprehensive description of the module itself, see the module's dedicated chapter.

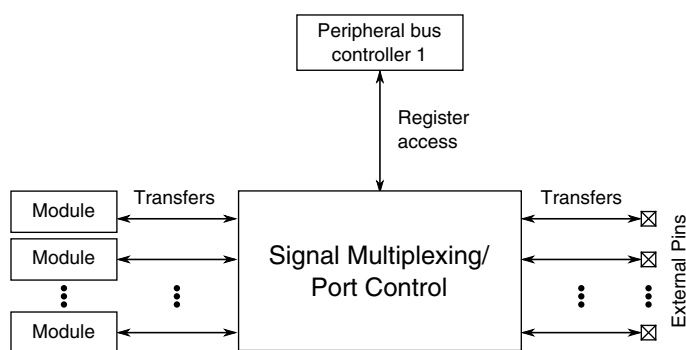

Figure 10-1. Signal multiplexing integration

Table 10-1. Reference links to related information

Topic	Related module	Reference
Full description	Port control	Port control
System memory map		System memory map

Table continues on the next page...

Table 10-1. Reference links to related information (continued)

Topic	Related module	Reference
Clocking		Clock Distribution
Register access	Peripheral bus controller	Peripheral bridge

10.2.1 Port control and interrupt module features

- Five 32-pin ports

NOTE

Not all pins are available on the device. See the following section for details.

- Each 32-pin port is assigned one interrupt.
- The digital filter option has two clock source options: bus clock and 1-kHz LPO. The 1-kHz LPO option gives users this feature in low power modes.
- The digital filter is configurable from 1 to 32 clock cycles when enabled.

10.2.2 Clock gating

The clock to the port control module can be gated on and off using the SCGC5[PORTx] bits in the SIM module. These bits are cleared after any reset, which disables the clock to the corresponding module to conserve power. Prior to initializing the corresponding module, set SCGC5[PORTx] in the SIM module to enable the clock. Before turning off the clock, make sure to disable the module. For more details, refer to the clock distribution chapter.

10.2.3 Signal multiplexing constraints

1. A given peripheral function must be assigned to a maximum of one package pin. Do not program the same function to more than one pin.
2. To ensure the best signal timing for a given peripheral's interface, choose the pins in closest proximity to each other.
3. For normal operation of the LCD, use ALT0 LCD functions. The ALT7 LCD functions are only available for LCD fault detection.

10.3 Pinout

10.3.1 K40 Signal Multiplexing and Pin Assignments

The following table shows the signals available on each pin and the locations of these pins on the devices supported by this document. The Port Control Module is responsible for selecting which ALT functionality is available on each pin.

100 LQFP	Pin Name	Default	ALT0	ALT1	ALT2	ALT3	ALT4	ALT5	ALT6	ALT7	EzPort
1	PTE0	ADC1_SE4a	ADC1_SE4a	PTE0	SPI1_PCS1	UART1_TX	SDHC0_D1		I2C1_SDA		
2	PTE1/ LLWU_P0	ADC1_SE5a	ADC1_SE5a	PTE1/ LLWU_P0	SPI1_SOUT	UART1_RX	SDHC0_D0		I2C1_SCL		
3	PTE2/ LLWU_P1	ADC1_SE6a	ADC1_SE6a	PTE2/ LLWU_P1	SPI1_SCK	UART1_CTS_b	SDHC0_DCLK				
4	PTE3	ADC1_SE7a	ADC1_SE7a	PTE3	SPI1_SIN	UART1_RTS_b	SDHC0_CMD				
5	PTE4/ LLWU_P2	DISABLED		PTE4/ LLWU_P2	SPI1_PCS0	UART3_TX	SDHC0_D3				
6	PTE5	DISABLED		PTE5	SPI1_PCS2	UART3_RX	SDHC0_D2				
7	PTE6	DISABLED		PTE6	SPI1_PCS3	UART3_CTS_b	I2S0_MCLK		I2S0_CLKIN		
8	VDD	VDD	VDD								
9	VSS	VSS	VSS								
10	USB0_DP	USB0_DP	USB0_DP								
11	USB0_DM	USB0_DM	USB0_DM								
12	VOUT33	VOUT33	VOUT33								
13	VREGIN	VREGIN	VREGIN								
14	ADC0_DP1	ADC0_DP1	ADC0_DP1								
15	ADC0_DM1	ADC0_DM1	ADC0_DM1								
16	ADC1_DP1	ADC1_DP1	ADC1_DP1								
17	ADC1_DM1	ADC1_DM1	ADC1_DM1								
18	PGA0_DP/ ADC0_DP0/ ADC1_DP3	PGA0_DP/ ADC0_DP0/ ADC1_DP3	PGA0_DP/ ADC0_DP0/ ADC1_DP3								
19	PGA0_DM/ ADC0_DM0/ ADC1_DM3	PGA0_DM/ ADC0_DM0/ ADC1_DM3	PGA0_DM/ ADC0_DM0/ ADC1_DM3								
20	PGA1_DP/ ADC1_DP0/ ADC0_DP3	PGA1_DP/ ADC1_DP0/ ADC0_DP3	PGA1_DP/ ADC1_DP0/ ADC0_DP3								
21	PGA1_DM/ ADC1_DM0/ ADC0_DM3	PGA1_DM/ ADC1_DM0/ ADC0_DM3	PGA1_DM/ ADC1_DM0/ ADC0_DM3								

Pinout

100 LQFP	Pin Name	Default	ALT0	ALT1	ALT2	ALT3	ALT4	ALT5	ALT6	ALT7	EzPort
22	VDDA	VDDA	VDDA								
23	VREFH	VREFH	VREFH								
24	VREFL	VREFL	VREFL								
25	VSSA	VSSA	VSSA								
26	VREF_OUT/ CMP1_IN5/ CMP0_IN5/ ADC1_SE18	VREF_OUT/ CMP1_IN5/ CMP0_IN5/ ADC1_SE18	VREF_OUT/ CMP1_IN5/ CMP0_IN5/ ADC1_SE18								
27	DAC0_OUT/ CMP1_IN3/ ADC0_SE23	DAC0_OUT/ CMP1_IN3/ ADC0_SE23	DAC0_OUT/ CMP1_IN3/ ADC0_SE23								
28	XTAL32	XTAL32	XTAL32								
29	EXTAL32	EXTAL32	EXTAL32								
30	VBAT	VBAT	VBAT								
31	PTE24	ADC0_SE17	ADC0_SE17	PTE24	CAN1_TX	UART4_TX			EWM_OUT_b		
32	PTE25	ADC0_SE18	ADC0_SE18	PTE25	CAN1_RX	UART4_RX			EWM_IN		
33	PTE26	DISABLED		PTE26		UART4_CTS_b			RTC_CLKOUT	USB_CLKIN	
34	PTA0	JTAG_TCLK/ SWD_CLK/ EZP_CLK	TSIO_CH1	PTA0	UART0_CTS_b	FTM0_CH5				JTAG_TCLK/ SWD_CLK	EZP_CLK
35	PTA1	JTAG_TDI/ EZP_DI	TSIO_CH2	PTA1	UART0_RX	FTM0_CH6				JTAG_TDI	EZP_DI
36	PTA2	JTAG_TDO/ TRACE_SWO/ EZP_DO	TSIO_CH3	PTA2	UART0_TX	FTM0_CH7				JTAG_TDO/ TRACE_SWO	EZP_DO
37	PTA3	JTAG_TMS/ SWD_DIO	TSIO_CH4	PTA3	UART0_RTS_b	FTM0_CH0				JTAG_TMS/ SWD_DIO	
38	PTA4/ LLWU_P3	NMI_b/ EZP_CS_b	TSIO_CH5	PTA4/ LLWU_P3		FTM0_CH1				NMI_b	EZP_CS_b
39	PTA5	DISABLED		PTA5		FTM0_CH2		CMP2_OUT	I2S0_RX_BCLK	JTAG_TRST	
40	VDD	VDD	VDD								
41	VSS	VSS	VSS								
42	PTA12	CMP2_IN0	CMP2_IN0	PTA12	CAN0_TX	FTM1_CH0			I2S0_TXD	FTM1_QD_PHA	
43	PTA13/ LLWU_P4	CMP2_IN1	CMP2_IN1	PTA13/ LLWU_P4	CAN0_RX	FTM1_CH1			I2S0_TX_FS	FTM1_QD_PHB	
44	PTA14	DISABLED		PTA14	SPI0_PCS0	UART0_TX			I2S0_TX_BCLK		
45	PTA15	DISABLED		PTA15	SPI0_SCK	UART0_RX			I2S0_RXD		
46	PTA16	DISABLED		PTA16	SPI0_SOUT	UART0_CTS_b			I2S0_RX_FS		
47	PTA17	ADC1_SE17	ADC1_SE17	PTA17	SPI0_SIN	UART0_RTS_b			I2S0_MCLK	I2S0_CLKIN	

100 LQFP	Pin Name	Default	ALT0	ALT1	ALT2	ALT3	ALT4	ALT5	ALT6	ALT7	EzPort
48	VDD	VDD	VDD								
49	VSS	VSS	VSS								
50	PTA18	EXTAL	EXTAL	PTA18		FTM0_FLT2	FTM_CLKIN0				
51	PTA19	XTAL	XTAL	PTA19		FTM1_FLT0	FTM_CLKIN1		LPT0_ALT1		
52	RESET_b	RESET_b	RESET_b								
53	PTB0/ LLWU_P5	LCD_P0/ ADC0_SE8/ ADC1_SE8/ TSIO_CH0	LCD_P0/ ADC0_SE8/ ADC1_SE8/ TSIO_CH0	PTB0/ LLWU_P5	I2C0_SCL	FTM1_CH0			FTM1_QD_PHA	LCD_P0	
54	PTB1	LCD_P1/ ADC0_SE9/ ADC1_SE9/ TSIO_CH6	LCD_P1/ ADC0_SE9/ ADC1_SE9/ TSIO_CH6	PTB1	I2C0_SDA	FTM1_CH1			FTM1_QD_PHB	LCD_P1	
55	PTB2	LCD_P2/ ADC0_SE12/ TSIO_CH7	LCD_P2/ ADC0_SE12/ TSIO_CH7	PTB2	I2C0_SCL	UART0_RTS_b			FTM0_FLT3	LCD_P2	
56	PTB3	LCD_P3/ ADC0_SE13/ TSIO_CH8	LCD_P3/ ADC0_SE13/ TSIO_CH8	PTB3	I2C0_SDA	UART0_CTS_b			FTM0_FLT0	LCD_P3	
57	PTB7	LCD_P7/ ADC1_SE13	LCD_P7/ ADC1_SE13	PTB7						LCD_P7	
58	PTB8	LCD_P8	LCD_P8	PTB8		UART3_RTS_b				LCD_P8	
59	PTB9	LCD_P9	LCD_P9	PTB9	SPI1_PCS1	UART3_CTS_b				LCD_P9	
60	PTB10	LCD_P10/ ADC1_SE14	LCD_P10/ ADC1_SE14	PTB10	SPI1_PCS0	UART3_RX			FTM0_FLT1	LCD_P10	
61	PTB11	LCD_P11/ ADC1_SE15	LCD_P11/ ADC1_SE15	PTB11	SPI1_SCK	UART3_TX			FTM0_FLT2	LCD_P11	
62	PTB16	LCD_P12/ TSIO_CH9	LCD_P12/ TSIO_CH9	PTB16	SPI1_SOUT	UART0_RX			EWM_IN	LCD_P12	
63	PTB17	LCD_P13/ TSIO_CH10	LCD_P13/ TSIO_CH10	PTB17	SPI1_SIN	UART0_TX			EWM_OUT_b	LCD_P13	
64	PTB18	LCD_P14/ TSIO_CH11	LCD_P14/ TSIO_CH11	PTB18	CAN0_TX	FTM2_CH0	I2S0_TX_BCLK		FTM2_QD_PHA	LCD_P14	
65	PTB19	LCD_P15/ TSIO_CH12	LCD_P15/ TSIO_CH12	PTB19	CAN0_RX	FTM2_CH1	I2S0_TX_FS		FTM2_QD_PHB	LCD_P15	
66	PTB20	LCD_P16	LCD_P16	PTB20	SPI2_PCS0				CMP0_OUT	LCD_P16	
67	PTB21	LCD_P17	LCD_P17	PTB21	SPI2_SCK				CMP1_OUT	LCD_P17	
68	PTB22	LCD_P18	LCD_P18	PTB22	SPI2_SOUT				CMP2_OUT	LCD_P18	
69	PTB23	LCD_P19	LCD_P19	PTB23	SPI2_SIN	SPI0_PCS5				LCD_P19	
70	PTC0	LCD_P20/ ADC0_SE14/ TSIO_CH13	LCD_P20/ ADC0_SE14/ TSIO_CH13	PTC0	SPI0_PCS4	PDB0_EXTRG	I2S0_TXD			LCD_P20	

Pinout

100 LQFP	Pin Name	Default	ALT0	ALT1	ALT2	ALT3	ALT4	ALT5	ALT6	ALT7	EzPort
71	PTC1/ LLWU_P6	LCD_P21/ ADC0_SE15/ TSI0_CH14	LCD_P21/ ADC0_SE15/ TSI0_CH14	PTC1/ LLWU_P6	SPI0_PCS3	UART1_RTS _b	FTM0_CH0			LCD_P21	
72	PTC2	LCD_P22/ ADC0_SE4b/ CMP1_IN0/ TSI0_CH15	LCD_P22/ ADC0_SE4b/ CMP1_IN0/ TSI0_CH15	PTC2	SPI0_PCS2	UART1_CTS _b	FTM0_CH1			LCD_P22	
73	PTC3/ LLWU_P7	LCD_P23/ CMP1_IN1	LCD_P23/ CMP1_IN1	PTC3/ LLWU_P7	SPI0_PCS1	UART1_RX	FTM0_CH2			LCD_P23	
74	VSS	VSS	VSS								
75	VLL3	VLL3	VLL3								
76	VLL2	VLL2	VLL2								
77	VLL1	VLL1	VLL1								
78	VCAP2	VCAP2	VCAP2								
79	VCAP1	VCAP1	VCAP1								
80	PTC4/ LLWU_P8	LCD_P24	LCD_P24	PTC4/ LLWU_P8	SPI0_PCS0	UART1_TX	FTM0_CH3		CMP1_OUT	LCD_P24	
81	PTC5/ LLWU_P9	LCD_P25	LCD_P25	PTC5/ LLWU_P9	SPI0_SCK		LPT0_ALT2		CMP0_OUT	LCD_P25	
82	PTC6/ LLWU_P10	LCD_P26/ CMP0_IN0	LCD_P26/ CMP0_IN0	PTC6/ LLWU_P10	SPI0_SOUT	PDB0_EXTR G				LCD_P26	
83	PTC7	LCD_P27/ CMP0_IN1	LCD_P27/ CMP0_IN1	PTC7	SPI0_SIN					LCD_P27	
84	PTC8	LCD_P28/ ADC1_SE4b/ CMP0_IN2	LCD_P28/ ADC1_SE4b/ CMP0_IN2	PTC8		I2S0_MCLK	I2S0_CLKIN			LCD_P28	
85	PTC9	LCD_P29/ ADC1_SE5b/ CMP0_IN3	LCD_P29/ ADC1_SE5b/ CMP0_IN3	PTC9			I2S0_RX_BC LK		FTM2_FLT0	LCD_P29	
86	PTC10	LCD_P30/ ADC1_SE6b/ CMP0_IN4	LCD_P30/ ADC1_SE6b/ CMP0_IN4	PTC10	I2C1_SCL		I2S0_RX_FS			LCD_P30	
87	PTC11/ LLWU_P11	LCD_P31/ ADC1_SE7b	LCD_P31/ ADC1_SE7b	PTC11/ LLWU_P11	I2C1_SDA		I2S0_RXD			LCD_P31	
88	VSS	VSS	VSS								
89	VDD	VDD	VDD								
90	PTC16	LCD_P36	LCD_P36	PTC16	CAN1_RX	UART3_RX				LCD_P36	
91	PTC17	LCD_P37	LCD_P37	PTC17	CAN1_TX	UART3_TX				LCD_P37	
92	PTC18	LCD_P38	LCD_P38	PTC18		UART3_RTS _b				LCD_P38	
93	PTD0/ LLWU_P12	LCD_P40	LCD_P40	PTD0/ LLWU_P12	SPI0_PCS0	UART2_RTS _b				LCD_P40	
94	PTD1	LCD_P41/ ADC0_SE5b	LCD_P41/ ADC0_SE5b	PTD1	SPI0_SCK	UART2_CTS _b				LCD_P41	
95	PTD2/ LLWU_P13	LCD_P42	LCD_P42	PTD2/ LLWU_P13	SPI0_SOUT	UART2_RX				LCD_P42	

100 LQFP	Pin Name	Default	ALT0	ALT1	ALT2	ALT3	ALT4	ALT5	ALT6	ALT7	EzPort
96	PTD3	LCD_P43	LCD_P43	PTD3	SPI0_SIN	UART2_TX				LCD_P43	
97	PTD4/ LLWU_P14	LCD_P44	LCD_P44	PTD4/ LLWU_P14	SPI0_PCS1	UART0_RTS_b	FTM0_CH4		EWM_IN	LCD_P44	
98	PTD5	LCD_P45/ ADC0_SE6b	LCD_P45/ ADC0_SE6b	PTD5	SPI0_PCS2	UART0_CTS_b	FTM0_CH5		EWM_OUT_b	LCD_P45	
99	PTD6/ LLWU_P15	LCD_P46/ ADC0_SE7b	LCD_P46/ ADC0_SE7b	PTD6/ LLWU_P15	SPI0_PCS3	UART0_RX	FTM0_CH6		FTM0_FLT0	LCD_P46	
100	PTD7	LCD_P47	LCD_P47	PTD7	CMT_IRO	UART0_TX	FTM0_CH7		FTM0_FLT1	LCD_P47	

10.3.2 K40 Pinouts

The below figure shows the pinout diagram for the devices supported by this document. Many signals may be multiplexed onto a single pin. To determine what signals can be used on which pin, see the previous section.

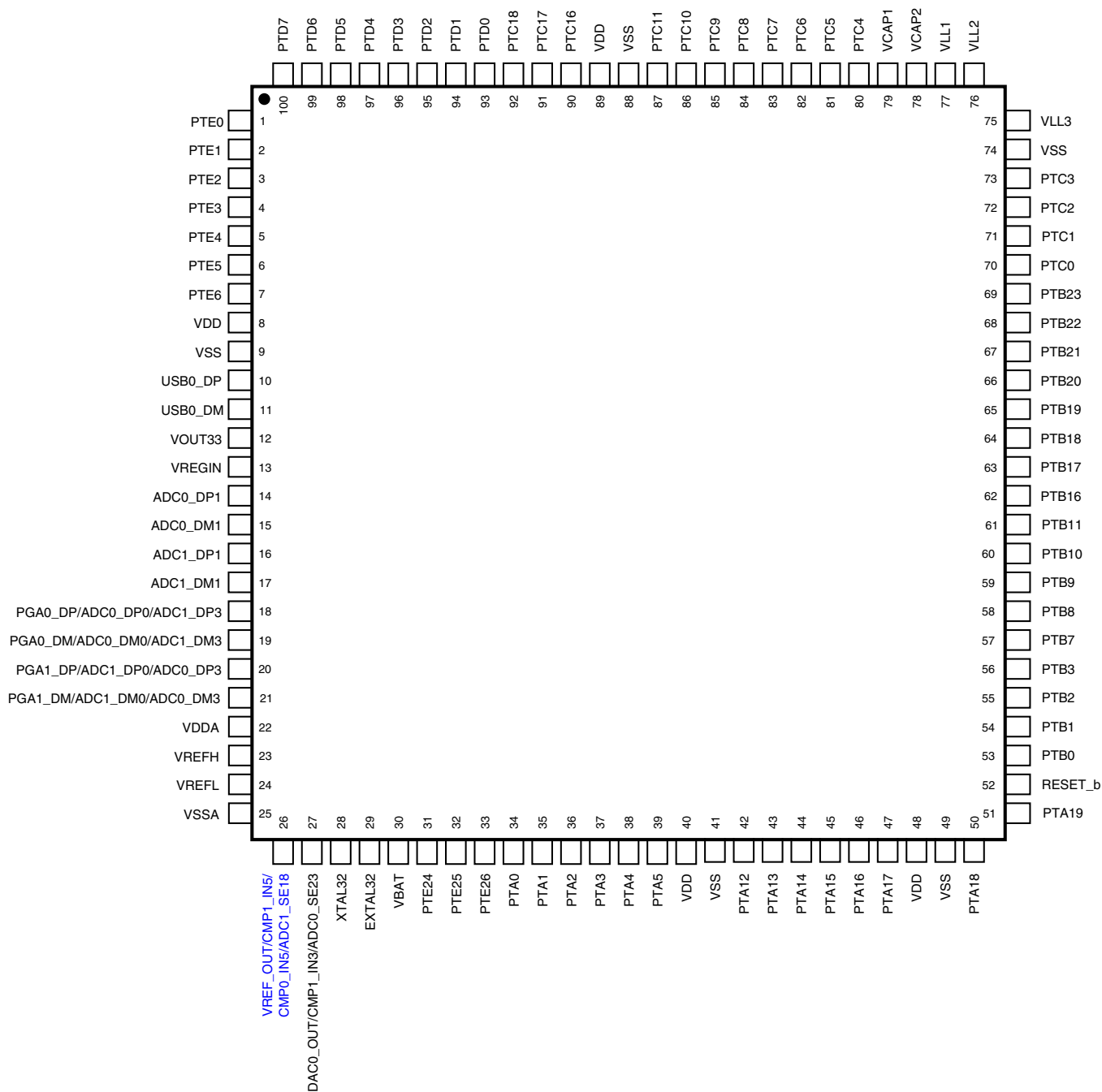

Figure 10-2. K40 100 LQFP Pinout Diagram

10.4 Module Signal Description Tables

The following sections correlate the chip-level signal name with the signal name used in the module's chapter. They also briefly describe the signal function and direction.

10.4.1 Core Modules

Table 10-2. JTAG Signal Descriptions

Chip signal name	Module signal name	Description	I/O
JTAG_TMS	JTAG_TMS/ SWD_DIO	JTAG Test Mode Selection	I/O
JTAG_TCLK	JTAG_TCLK/ SWD_CLK	JTAG Test Clock	I
JTAG_TDI	JTAG_TDI	JTAG Test Data Input	I
JTAG_TDO	JTAG_TDO/ TRACE_SWO	JTAG Test Data Output	O
JTAG_TRST	JTAG_TRST_b	JTAG Reset	I

Table 10-3. SWD Signal Descriptions

Chip signal name	Module signal name	Description	I/O
SWD_DIO	JTAG_TMS/ SWD_DIO	Serial Wire Data	I/O
SWD_CLK	JTAG_TCLK/ SWD_CLK	Serial Wire Clock	I

Table 10-4. TPIU Signal Descriptions

Chip signal name	Module signal name	Description	I/O
TRACE_CLKOUT	TRACECLK	Trace clock output from the ARM CoreSight debug block	O
TRACE_D[3:2]	TRACEDATA	Trace output data from the ARM CoreSight debug block used for 5-pin interface	O
TRACE_D[1:0]	TRACEDATA	Trace output data from the ARM CoreSight debug block used for both 5-pin and 3-pin interfaces	O
TRACE_SWO	JTAG_TDO/ TRACE_SWO	Trace output data from the ARM CoreSight debug block over a single pin	O

10.4.2 System Modules

Table 10-5. System Signal Descriptions

Chip signal name	Module signal name	Description	I/O
NMI	—	Non-maskable interrupt NOTE: Driving the $\overline{\text{NMI}}$ signal low forces a non-maskable interrupt, if the $\overline{\text{NMI}}$ function is selected on the corresponding pin.	I

Table continues on the next page...

Table 10-5. System Signal Descriptions (continued)

Chip signal name	Module signal name	Description	I/O
RESET	—	Reset bi-directional signal	I/O
VDD	—	MCU power	I
VSS	—	MCU ground	I

Table 10-6. EWM Signal Descriptions

Chip signal name	Module signal name	Description	I/O
EWM_IN	EWM_in	EWM input for safety status of external safety circuits. The polarity of EWM_in is programmable using the CTRL[ASSIN] bit. The default polarity is active-low.	I
EWM_OUT	EWM_out	EWM reset out signal	O

10.4.3 Clock Modules

Table 10-7. OSC Signal Descriptions

Chip signal name	Module signal name	Description	I/O
EXTAL0	EXTAL	External clock/Oscillator input	I
XTAL0	XTAL	Oscillator output	O

Table 10-8. RTC OSC Signal Descriptions

Chip signal name	Module signal name	Description	I/O
EXTAL32	EXTAL32	32.768 kHz oscillator input	I
XTAL32	XTAL32	32.768 kHz oscillator output	O

10.4.4 Memories and Memory Interfaces

Table 10-9. EzPort Signal Descriptions

Chip signal name	Module signal name	Description	I/O
EZP_CLK	EZP_CK	EzPort Clock	Input
EZP_CS	EZP_CS	EzPort Chip Select	Input
EZP_DI	EZP_D	EzPort Serial Data In	Input
EZP_DO	EZP_Q	EzPort Serial Data Out	Output

10.4.5 Security Modules

Table 10-10. Tamper Detect Signal Descriptions

Chip signal name	Module signal name	Description	I/O
1	TAMPER[7:0]	External tamper input or active tamper output	I/O

- The TAMPER signals have dedicated pins and are not included in the JTAG boundary scan. TAMPER0 is an exception because it is priority muxed with the RTC_WAKEUP function. If TAMPER0 is enabled as either an input or output, the RTC_WAKEUP function is disabled. The RTC_WAKEUP pin can be configured to assert on a Tamper Detect, if the RTC enables the DryIce tamper detect interrupt.

10.4.6 Analog

Table 10-11. ADC 0 Signal Descriptions

Chip signal name	Module signal name	Description	I/O
ADC0_DP3, PGA0_DP, ADC0_DP[1:0]	DADP[3:0]	Differential analog channel inputs	I
ADC0_DM3, PGA0_DM, ADC0_DM[1:0]	DADM[3:0]	Differential analog channel inputs	I
ADC0_SE[18,17,15: 12,9:4]18,17,15:12,9: 4]	AD[23:4]	Single-ended analog channel inputs	I
VREFH	V _{REFSH}	Voltage reference select high	I
VREFL	V _{REFSL}	Voltage reference select low	I
VDDA	V _{DDA}	Analog power supply	I
VSSA	V _{SSA}	Analog ground	I

Table 10-12. ADC 1 Signal Descriptions

Chip signal name	Module signal name	Description	I/O
ADC1_DP3, PGA1_DP, ADC1_DP[1:0]	DADP[3:0]	Differential analog channel inputs	I
ADC1_DM3, PGA1_DM, ADC1_DM[1:0]	DADM[3:0]	Differential analog channel inputs	I
ADC1_SE[18:17,15: 13,9:4]	AD[23:4]	Single-ended analog channel inputs	I
VREFH	V _{REFSH}	Voltage reference select high	I

Table continues on the next page...

Table 10-12. ADC 1 Signal Descriptions (continued)

Chip signal name	Module signal name	Description	I/O
VREFL	V _{REFSL}	Voltage reference select low	I
VDDA	V _{DDA}	Analog power supply	I
VSSA	V _{SSA}	Analog ground	I

Table 10-13. CMP 0 Signal Descriptions

Chip signal name	Module signal name	Description	I/O
CMP0_IN[5:0]	IN[5:0]	Analog voltage inputs	I
CMP0_OUT	CMPO	Comparator output	O

Table 10-14. CMP 1 Signal Descriptions

Chip signal name	Module signal name	Description	I/O
CMP1_IN[5:0]	IN[5:0]	Analog voltage inputs	I
CMP1_OUT	CMPO	Comparator output	O

Table 10-15. CMP 2 Signal Descriptions

Chip signal name	Module signal name	Description	I/O
CMP2_IN[5:0]	IN[5:0]	Analog voltage inputs	I
CMP2_OUT	CMPO	Comparator output	O

Table 10-16. DAC 0 Signal Descriptions

Chip signal name	Module signal name	Description	I/O
DAC0_OUT	—	DAC output	O

Table 10-17. TRIAMP 1 Signal Descriptions

Chip signal name	Module signal name	Description	I/O
TRI1_DP	inp_3v	Amplifier positive input terminal	I
TRI1_DM	inn_3v	Amplifier negative input terminal	I
TRI1_OUT	out_3v	Amplifier output terminal	O

Table 10-18. VREF Signal Descriptions

Chip signal name	Module signal name	Description	I/O
VREF_OUT	VREF_OUT	Internally-generated Voltage Reference output	O

10.4.7 Communication Interfaces

Table 10-19. USB FS OTG Signal Descriptions

Chip signal name	Module signal name	Description	I/O
USB0_DM	usb_dm	USB D- analog data signal on the USB bus.	I/O
USB0_DP	usb_dp	USB D+ analog data signal on the USB bus.	I/O
USB_CLKIN	—	Alternate USB clock input	I

Table 10-20. USB VREG Signal Descriptions

Chip signal name	Module signal name	Description	I/O
VOUT33	reg33_out	Regulator output voltage	O
VREGIN	reg33_in	Unregulated power supply	I

Table 10-21. CAN 0 Signal Descriptions

Chip signal name	Module signal name	Description	I/O
CAN0_RX	CAN Rx	CAN Receive Pin	Input
CAN0_TX	CAN Tx	CAN Transmit Pin	Output

Table 10-22. CAN 1 Signal Descriptions

Chip signal name	Module signal name	Description	I/O
CAN1_RX	CAN Rx	CAN Receive Pin	Input
CAN1_TX	CAN Tx	CAN Transmit Pin	Output

Table 10-23. SPI 0 Signal Descriptions

Chip signal name	Module signal name	Description	I/O
SPI0_PCS0	PCS0/ \overline{SS}	Master mode: Peripheral Chip Select 0 output Slave mode: Slave Select input	I/O

Table continues on the next page...

Table 10-23. SPI 0 Signal Descriptions (continued)

Chip signal name	Module signal name	Description	I/O
SPI0_PCS[3:1]	PCS[3:1]	Master mode: Peripheral Chip Select 1 - 3 Slave mode: Unused	O
SPI0_PCS4	PCS4	Master mode: Peripheral Chip Select 4 Slave mode: Unused	O
SPI0_PCS5	PCS5/ \overline{PCSS}	Master mode: Peripheral Chip Select 5 / Peripheral Chip Select Strobe Slave mode: Unused	O
SPI0_SIN	SIN	Serial Data In	I
SPI0_SOUT	SOUT	Serial Data Out	O
SPI0_SCK	SCK	Master mode: Serial Clock (output) Slave mode: Serial Clock (input)	I/O

Table 10-24. I²C 0 Signal Descriptions

Chip signal name	Module signal name	Description	I/O
I2C0_SCL	SCL	Bidirectional serial clock line of the I ² C system.	I/O
I2C0_SDA	SDA	Bidirectional serial data line of the I ² C system.	I/O

Table 10-25. I²C 1 Signal Descriptions

Chip signal name	Module signal name	Description	I/O
I2C1_SCL	SCL	Bidirectional serial clock line of the I ² C system.	I/O
I2C1_SDA	SDA	Bidirectional serial data line of the I ² C system.	I/O

Table 10-26. UART 0 Signal Descriptions

Chip signal name	Module signal name	Description	I/O
UART0_CTS	\overline{CTS}	Clear to send	I
UART0_RTS	\overline{RTS}	Request to send	O
UART0_TX	TXD	Transmit data	O
UART0_RX	RXD	Receive data	I

Table 10-27. UART 1 Signal Descriptions

Chip signal name	Module signal name	Description	I/O
UART1_CTS	\overline{CTS}	Clear to send	I

Table continues on the next page...

Table 10-27. UART 1 Signal Descriptions (continued)

Chip signal name	Module signal name	Description	I/O
UART1_RTS	RTS	Request to send	O
UART1_TX	TXD	Transmit data	O
UART1_RX	RXD	Receive data	I

Table 10-28. UART 2 Signal Descriptions

Chip signal name	Module signal name	Description	I/O
UART2_CTS	$\overline{\text{CTS}}$	Clear to send	I
UART2_RTS	RTS	Request to send	O
UART2_TX	TXD	Transmit data	O
UART2_RX	RXD	Receive data	I

Table 10-29. UART 3 Signal Descriptions

Chip signal name	Module signal name	Description	I/O
UART3_CTS	$\overline{\text{CTS}}$	Clear to send	I
UART3_RTS	RTS	Request to send	O
UART3_TX	TXD	Transmit data	O
UART3_RX	RXD	Receive data	I

Table 10-30. UART 4 Signal Descriptions

Chip signal name	Module signal name	Description	I/O
UART4_CTS	$\overline{\text{CTS}}$	Clear to send	I
UART4_RTS	RTS	Request to send	O
UART4_TX	TXD	Transmit data	O
UART4_RX	RXD	Receive data	I

Table 10-31. SDHC Signal Descriptions

Chip signal name	Module signal name	Description	I/O
SDHC0_DCLK	SDHC_DCLK	Generated clock used to drive the MMC, SD, SDIO or CE-ATA cards.	O
SDHC0_CMD	SDHC_CMD	Send commands to and receive responses from the card.	I/O
SDHC0_D0	SDHC_D0	DAT0 line or busy-state detect	I/O

Table continues on the next page...

Table 10-31. SDHC Signal Descriptions (continued)

Chip signal name	Module signal name	Description	I/O
SDHC0_D1	SDHC_D1	8-bit mode: DAT1 line 4-bit mode: DAT1 line or interrupt detect 1-bit mode: Interrupt detect	I/O
SDHC0_D2	SDHC_D2	4-/8-bit mode: DAT2 line or read wait 1-bit mode: Read wait	I/O
SDHC0_D3	SDHC_D3	4-/8-bit mode: DAT3 line or configured as card detection pin 1-bit mode: May be configured as card detection pin	I/O

Table 10-32. I²S 0 Signal Descriptions

Chip signal name	Module signal name	Description	I/O
I2S0_MCLK	—	Serial master clock output	I/O
I2S0_RX_BCLK	SRCK	Serial receive clock. SRCK can be used as an input or output. <ul style="list-style-type: none"> In asynchronous mode the receiver uses this clock signal and it is always continuous. In synchronous mode, the STCK port is used instead for clocking in data. 	I/O
I2S0_RX_FS	SRFS	Serial receive frame Sync. The SRFS port can be used as an input or output. The frame sync is used by the receiver to synchronize the transfer of data. The frame sync signal can be one bit or one word in length and can occur one bit before the transfer of data or right at the transfer of data. If SRFS is configured as an input, the external device should drive SRFS during the rising edge of STCK or SRCK.	I/O
I2S0_RXD	SRXD	Serial receive data. The SRXD port is an input and is used to bring serial data into the receive data shift register.	I
I2S0_TX_BCLK	STCK	Serial transmit clock. The STCK port can be used as an input or output. This clock signal is used by the transmitter and can be continuous or gated. During gated clock mode, data on STCK is valid only during the transmission of data. Otherwise, it is pulled to the inactive state. In synchronous mode, this port is used by the transmit and receive sections.	I/O
I2S0_TX_FS	STFS	Serial transmit frame sync. The STFS port can be used as an input or output. The frame sync is used by the transmitter to synchronize the transfer of data. The frame sync signal can be one bit or one word in length and can occur one bit before the transfer of data or right at the transfer of data. In synchronous mode, this port is used by both the transmit and receive sections. In gated clock mode, frame sync signals are not used. If STFS is configured as an input, the external device should drive STFS during the rising edge of STCK if TSCKP is positive-edge triggered. The external device should drive STFS during the falling edge of STCK if TSCKP is negative-edge triggered.	I/O

Table continues on the next page...

Table 10-32. I²S 0 Signal Descriptions (continued)

Chip signal name	Module signal name	Description	I/O
I2S0_TXD	STXD	Serial transmit data. The STXD port is an output and transmits data from the serial transmit shift register. The STXD port is an output port when data is being transmitted and is disabled between data word transmissions and on the trailing edge of the bit clock after the last bit of a word is transmitted.	O

10.4.8 Human-Machine Interfaces (HMI)

Table 10-33. GPIO Signal Descriptions

Chip signal name	Module signal name	Description	I/O
PTA[31:0] ¹	PORTA[31:0]	General purpose input/output	I/O
PTB[31:0] ¹	PORTB[31:0]	General purpose input/output	I/O
PTC[31:0] ¹	PORTC[31:0]	General purpose input/output	I/O
PTD[31:0] ¹	PORTD[31:0]	General purpose input/output	I/O
PTE[31:0] ¹	PORTE[31:0]	General purpose input/output	I/O

1. The available GPIO pins depends on the specific package. See the signal multiplexing section for which exact GPIO signals are available.

Table 10-34. TSI 0 Signal Descriptions

Chip signal name	Module signal name	Description	I/O
TSI0_CH[15:0]	TSI_IN[15:0]	TSI pins. Switchable driver that connects directly to the electrode pins TSI[15:0] can operate as GPIO pins	I/O

Table 10-35. Segment LCD Signal Descriptions

Chip signal name	Module signal name	Description	I/O
LCD_P[47:0] ¹	LCD_P[63:0]. 64 LCD frontplane/backplane	Configurable frontplane/backplane driver that connects directly to the display LCD_P[63:0] can operate as GPIO pins	O
VLL[3:1]	V _{LL1} , V _{LL2} , V _{LL3} . LCD bias voltages	LCD bias voltages	I/O
VCAP[2:1]	V _{cap1} , V _{cap2} . LCD charge pump capacitance	Charge pump capacitor pins	O

1. The available LCD pins depends on the specific package. See the signal multiplexing section for which exact LCD signals are available.



Chapter 11

Port control and interrupts (PORT)

11.1 Introduction

NOTE

For the chip-specific implementation details of this module's instances see the chip configuration chapter.

11.1.1 Overview

The port control and interrupt (PORT) module provides support for external interrupt, digital filtering and port control functions. Most functions can be configured independently for each pin in the 32-bit port and affect the pin regardless of its pin muxing state.

There is one instance of the PORT module for each port. Not all pins within each port are implemented on a specific device.

11.1.2 Features

- Pin interrupt
 - Interrupt flag and enable registers for each pin
 - Supports edge sensitive (rising, falling, both) or level sensitive (low, high) configured per pin
 - Support for interrupt or DMA request configured per pin
 - Asynchronous wakeup in low-power modes
 - Pin interrupt is functional in all digital pin muxing modes
- Digital input filter
 - Digital input filter for each pin, usable by any digital peripheral muxed onto pin
 - Individual enable or bypass control bit per pin

- Selectable clock source for digital input filter with 5-bit resolution on filter size
- Digital filter is functional in all digital pin muxing modes
- Port control
 - Individual pull control registers with pullup, pulldown and pull-disable support
 - Individual drive strength register supporting high and low drive strength
 - Individual slew rate register supporting fast and slow slew rates
 - Individual input passive filter register supporting enabled and disabled
 - Individual open-drain register supporting enabled and disabled
 - Individual mux control register supporting analog (or pin disabled), GPIO plus up to six chip specific digital functions
 - Pad configuration registers are functional in all digital pin muxing modes

11.1.3 Modes of operation

11.1.3.1 Run mode

In run mode, the PORT operates normally.

11.1.3.2 Wait mode

In wait mode, the PORT continues to operate normally and may be configured to exit the low power mode if an enabled interrupt is detected. DMA requests are still generated during wait mode, but do not cause an exit from the low power mode.

11.1.3.3 Stop mode

In stop mode, the digital input filters are bypassed unless they are configured to run from the 1 kHz LPO clock source. The PORT can be configured to exit the low power mode via an asynchronous wakeup signal if an enabled interrupt (but not DMA request) is detected.

11.1.3.4 Debug mode

In debug mode, the PORTx operates normally.

11.2 External signal description

Table 11-1. Signal properties

Name	Function	I/O	Reset	Pull
PORTx[31:0]	External interrupt	I/O	0	-

NOTE

Not all pins within each port are implemented on each device.

11.3 Detailed signal descriptions

Table 11-2. PORTx interface-detailed signal descriptions

Signal	I/O	Description	
PORTx[31:0]	I/O	External interrupt.	
		State meaning	Asserted-pin is logic one. Negated-pin is logic zero.
		Timing	Assertion-may occur at any time and can assert asynchronously to the system clock. Negation-may occur at any time and can assert asynchronously to the system clock.

11.4 Memory map and register definition

Any read or write access to the PORT memory space that is outside the valid memory map results in a bus error. All register accesses complete with zero wait states.

PORT memory map

Absolute address (hex)	Register name	Width (in bits)	Access	Reset value	Section/page
4004_9000	Pin Control Register n (PORTA_PCR0)	32	R/W	0000_0000h	11.4.1/244
4004_9004	Pin Control Register n (PORTA_PCR1)	32	R/W	0000_0000h	11.4.1/244
4004_9008	Pin Control Register n (PORTA_PCR2)	32	R/W	0000_0000h	11.4.1/244

Table continues on the next page...

PORT memory map (continued)

Absolute address (hex)	Register name	Width (in bits)	Access	Reset value	Section/page
4004_900C	Pin Control Register n (PORTA_PCR3)	32	R/W	0000_0000h	11.4.1/244
4004_9010	Pin Control Register n (PORTA_PCR4)	32	R/W	0000_0000h	11.4.1/244
4004_9014	Pin Control Register n (PORTA_PCR5)	32	R/W	0000_0000h	11.4.1/244
4004_9018	Pin Control Register n (PORTA_PCR6)	32	R/W	0000_0000h	11.4.1/244
4004_901C	Pin Control Register n (PORTA_PCR7)	32	R/W	0000_0000h	11.4.1/244
4004_9020	Pin Control Register n (PORTA_PCR8)	32	R/W	0000_0000h	11.4.1/244
4004_9024	Pin Control Register n (PORTA_PCR9)	32	R/W	0000_0000h	11.4.1/244
4004_9028	Pin Control Register n (PORTA_PCR10)	32	R/W	0000_0000h	11.4.1/244
4004_902C	Pin Control Register n (PORTA_PCR11)	32	R/W	0000_0000h	11.4.1/244
4004_9030	Pin Control Register n (PORTA_PCR12)	32	R/W	0000_0000h	11.4.1/244
4004_9034	Pin Control Register n (PORTA_PCR13)	32	R/W	0000_0000h	11.4.1/244
4004_9038	Pin Control Register n (PORTA_PCR14)	32	R/W	0000_0000h	11.4.1/244
4004_903C	Pin Control Register n (PORTA_PCR15)	32	R/W	0000_0000h	11.4.1/244
4004_9040	Pin Control Register n (PORTA_PCR16)	32	R/W	0000_0000h	11.4.1/244
4004_9044	Pin Control Register n (PORTA_PCR17)	32	R/W	0000_0000h	11.4.1/244
4004_9048	Pin Control Register n (PORTA_PCR18)	32	R/W	0000_0000h	11.4.1/244
4004_904C	Pin Control Register n (PORTA_PCR19)	32	R/W	0000_0000h	11.4.1/244
4004_9050	Pin Control Register n (PORTA_PCR20)	32	R/W	0000_0000h	11.4.1/244
4004_9054	Pin Control Register n (PORTA_PCR21)	32	R/W	0000_0000h	11.4.1/244
4004_9058	Pin Control Register n (PORTA_PCR22)	32	R/W	0000_0000h	11.4.1/244
4004_905C	Pin Control Register n (PORTA_PCR23)	32	R/W	0000_0000h	11.4.1/244
4004_9060	Pin Control Register n (PORTA_PCR24)	32	R/W	0000_0000h	11.4.1/244
4004_9064	Pin Control Register n (PORTA_PCR25)	32	R/W	0000_0000h	11.4.1/244
4004_9068	Pin Control Register n (PORTA_PCR26)	32	R/W	0000_0000h	11.4.1/244
4004_906C	Pin Control Register n (PORTA_PCR27)	32	R/W	0000_0000h	11.4.1/244
4004_9070	Pin Control Register n (PORTA_PCR28)	32	R/W	0000_0000h	11.4.1/244
4004_9074	Pin Control Register n (PORTA_PCR29)	32	R/W	0000_0000h	11.4.1/244
4004_9078	Pin Control Register n (PORTA_PCR30)	32	R/W	0000_0000h	11.4.1/244
4004_907C	Pin Control Register n (PORTA_PCR31)	32	R/W	0000_0000h	11.4.1/244
4004_9080	Global Pin Control Low Register (PORTA_GPCLR)	32	W (always reads zero)	0000_0000h	11.4.2/246
4004_9084	Global Pin Control High Register (PORTA_GPCHR)	32	W (always	0000_0000h	11.4.3/247

Table continues on the next page...

PORT memory map (continued)

Absolute address (hex)	Register name	Width (in bits)	Access	Reset value	Section/page
			reads zero)		
4004_90A0	Interrupt Status Flag Register (PORTA_ISFR)	32	w1c	0000_0000h	11.4.4/247
4004_90C0	Digital Filter Enable Register (PORTA_DFER)	32	R/W	0000_0000h	11.4.5/248
4004_90C4	Digital Filter Clock Register (PORTA_DFCR)	32	R/W	0000_0000h	11.4.6/249
4004_90C8	Digital Filter Width Register (PORTA_DFWR)	32	R/W	0000_0000h	11.4.7/249
4004_A000	Pin Control Register n (PORTB_PCR0)	32	R/W	0000_0000h	11.4.1/244
4004_A004	Pin Control Register n (PORTB_PCR1)	32	R/W	0000_0000h	11.4.1/244
4004_A008	Pin Control Register n (PORTB_PCR2)	32	R/W	0000_0000h	11.4.1/244
4004_A00C	Pin Control Register n (PORTB_PCR3)	32	R/W	0000_0000h	11.4.1/244
4004_A010	Pin Control Register n (PORTB_PCR4)	32	R/W	0000_0000h	11.4.1/244
4004_A014	Pin Control Register n (PORTB_PCR5)	32	R/W	0000_0000h	11.4.1/244
4004_A018	Pin Control Register n (PORTB_PCR6)	32	R/W	0000_0000h	11.4.1/244
4004_A01C	Pin Control Register n (PORTB_PCR7)	32	R/W	0000_0000h	11.4.1/244
4004_A020	Pin Control Register n (PORTB_PCR8)	32	R/W	0000_0000h	11.4.1/244
4004_A024	Pin Control Register n (PORTB_PCR9)	32	R/W	0000_0000h	11.4.1/244
4004_A028	Pin Control Register n (PORTB_PCR10)	32	R/W	0000_0000h	11.4.1/244
4004_A02C	Pin Control Register n (PORTB_PCR11)	32	R/W	0000_0000h	11.4.1/244
4004_A030	Pin Control Register n (PORTB_PCR12)	32	R/W	0000_0000h	11.4.1/244
4004_A034	Pin Control Register n (PORTB_PCR13)	32	R/W	0000_0000h	11.4.1/244
4004_A038	Pin Control Register n (PORTB_PCR14)	32	R/W	0000_0000h	11.4.1/244
4004_A03C	Pin Control Register n (PORTB_PCR15)	32	R/W	0000_0000h	11.4.1/244
4004_A040	Pin Control Register n (PORTB_PCR16)	32	R/W	0000_0000h	11.4.1/244
4004_A044	Pin Control Register n (PORTB_PCR17)	32	R/W	0000_0000h	11.4.1/244
4004_A048	Pin Control Register n (PORTB_PCR18)	32	R/W	0000_0000h	11.4.1/244
4004_A04C	Pin Control Register n (PORTB_PCR19)	32	R/W	0000_0000h	11.4.1/244
4004_A050	Pin Control Register n (PORTB_PCR20)	32	R/W	0000_0000h	11.4.1/244
4004_A054	Pin Control Register n (PORTB_PCR21)	32	R/W	0000_0000h	11.4.1/244
4004_A058	Pin Control Register n (PORTB_PCR22)	32	R/W	0000_0000h	11.4.1/244
4004_A05C	Pin Control Register n (PORTB_PCR23)	32	R/W	0000_0000h	11.4.1/244
4004_A060	Pin Control Register n (PORTB_PCR24)	32	R/W	0000_0000h	11.4.1/244
4004_A064	Pin Control Register n (PORTB_PCR25)	32	R/W	0000_0000h	11.4.1/244
4004_A068	Pin Control Register n (PORTB_PCR26)	32	R/W	0000_0000h	11.4.1/244
4004_A06C	Pin Control Register n (PORTB_PCR27)	32	R/W	0000_0000h	11.4.1/244

Table continues on the next page...

PORT memory map (continued)

Absolute address (hex)	Register name	Width (in bits)	Access	Reset value	Section/page
4004_A070	Pin Control Register n (PORTB_PCR28)	32	R/W	0000_0000h	11.4.1/244
4004_A074	Pin Control Register n (PORTB_PCR29)	32	R/W	0000_0000h	11.4.1/244
4004_A078	Pin Control Register n (PORTB_PCR30)	32	R/W	0000_0000h	11.4.1/244
4004_A07C	Pin Control Register n (PORTB_PCR31)	32	R/W	0000_0000h	11.4.1/244
4004_A080	Global Pin Control Low Register (PORTB_GPCLR)	32	W (always reads zero)	0000_0000h	11.4.2/246
4004_A084	Global Pin Control High Register (PORTB_GPCHR)	32	W (always reads zero)	0000_0000h	11.4.3/247
4004_A0A0	Interrupt Status Flag Register (PORTB_ISFR)	32	w1c	0000_0000h	11.4.4/247
4004_A0C0	Digital Filter Enable Register (PORTB_DFER)	32	R/W	0000_0000h	11.4.5/248
4004_A0C4	Digital Filter Clock Register (PORTB_DFRCR)	32	R/W	0000_0000h	11.4.6/249
4004_A0C8	Digital Filter Width Register (PORTB_DFWR)	32	R/W	0000_0000h	11.4.7/249
4004_B000	Pin Control Register n (PORTC_PCR0)	32	R/W	0000_0000h	11.4.1/244
4004_B004	Pin Control Register n (PORTC_PCR1)	32	R/W	0000_0000h	11.4.1/244
4004_B008	Pin Control Register n (PORTC_PCR2)	32	R/W	0000_0000h	11.4.1/244
4004_B00C	Pin Control Register n (PORTC_PCR3)	32	R/W	0000_0000h	11.4.1/244
4004_B010	Pin Control Register n (PORTC_PCR4)	32	R/W	0000_0000h	11.4.1/244
4004_B014	Pin Control Register n (PORTC_PCR5)	32	R/W	0000_0000h	11.4.1/244
4004_B018	Pin Control Register n (PORTC_PCR6)	32	R/W	0000_0000h	11.4.1/244
4004_B01C	Pin Control Register n (PORTC_PCR7)	32	R/W	0000_0000h	11.4.1/244
4004_B020	Pin Control Register n (PORTC_PCR8)	32	R/W	0000_0000h	11.4.1/244
4004_B024	Pin Control Register n (PORTC_PCR9)	32	R/W	0000_0000h	11.4.1/244
4004_B028	Pin Control Register n (PORTC_PCR10)	32	R/W	0000_0000h	11.4.1/244
4004_B02C	Pin Control Register n (PORTC_PCR11)	32	R/W	0000_0000h	11.4.1/244
4004_B030	Pin Control Register n (PORTC_PCR12)	32	R/W	0000_0000h	11.4.1/244
4004_B034	Pin Control Register n (PORTC_PCR13)	32	R/W	0000_0000h	11.4.1/244
4004_B038	Pin Control Register n (PORTC_PCR14)	32	R/W	0000_0000h	11.4.1/244
4004_B03C	Pin Control Register n (PORTC_PCR15)	32	R/W	0000_0000h	11.4.1/244
4004_B040	Pin Control Register n (PORTC_PCR16)	32	R/W	0000_0000h	11.4.1/244
4004_B044	Pin Control Register n (PORTC_PCR17)	32	R/W	0000_0000h	11.4.1/244
4004_B048	Pin Control Register n (PORTC_PCR18)	32	R/W	0000_0000h	11.4.1/244
4004_B04C	Pin Control Register n (PORTC_PCR19)	32	R/W	0000_0000h	11.4.1/244

Table continues on the next page...

PORT memory map (continued)

Absolute address (hex)	Register name	Width (in bits)	Access	Reset value	Section/page
4004_B050	Pin Control Register n (PORTC_PCR20)	32	R/W	0000_0000h	11.4.1/244
4004_B054	Pin Control Register n (PORTC_PCR21)	32	R/W	0000_0000h	11.4.1/244
4004_B058	Pin Control Register n (PORTC_PCR22)	32	R/W	0000_0000h	11.4.1/244
4004_B05C	Pin Control Register n (PORTC_PCR23)	32	R/W	0000_0000h	11.4.1/244
4004_B060	Pin Control Register n (PORTC_PCR24)	32	R/W	0000_0000h	11.4.1/244
4004_B064	Pin Control Register n (PORTC_PCR25)	32	R/W	0000_0000h	11.4.1/244
4004_B068	Pin Control Register n (PORTC_PCR26)	32	R/W	0000_0000h	11.4.1/244
4004_B06C	Pin Control Register n (PORTC_PCR27)	32	R/W	0000_0000h	11.4.1/244
4004_B070	Pin Control Register n (PORTC_PCR28)	32	R/W	0000_0000h	11.4.1/244
4004_B074	Pin Control Register n (PORTC_PCR29)	32	R/W	0000_0000h	11.4.1/244
4004_B078	Pin Control Register n (PORTC_PCR30)	32	R/W	0000_0000h	11.4.1/244
4004_B07C	Pin Control Register n (PORTC_PCR31)	32	R/W	0000_0000h	11.4.1/244
4004_B080	Global Pin Control Low Register (PORTC_GPCLR)	32	W (always reads zero)	0000_0000h	11.4.2/246
4004_B084	Global Pin Control High Register (PORTC_GPCHR)	32	W (always reads zero)	0000_0000h	11.4.3/247
4004_B0A0	Interrupt Status Flag Register (PORTC_ISFR)	32	w1c	0000_0000h	11.4.4/247
4004_B0C0	Digital Filter Enable Register (PORTC_DFER)	32	R/W	0000_0000h	11.4.5/248
4004_B0C4	Digital Filter Clock Register (PORTC_DFCR)	32	R/W	0000_0000h	11.4.6/249
4004_B0C8	Digital Filter Width Register (PORTC_DFWR)	32	R/W	0000_0000h	11.4.7/249
4004_C000	Pin Control Register n (PORTD_PCR0)	32	R/W	0000_0000h	11.4.1/244
4004_C004	Pin Control Register n (PORTD_PCR1)	32	R/W	0000_0000h	11.4.1/244
4004_C008	Pin Control Register n (PORTD_PCR2)	32	R/W	0000_0000h	11.4.1/244
4004_C00C	Pin Control Register n (PORTD_PCR3)	32	R/W	0000_0000h	11.4.1/244
4004_C010	Pin Control Register n (PORTD_PCR4)	32	R/W	0000_0000h	11.4.1/244
4004_C014	Pin Control Register n (PORTD_PCR5)	32	R/W	0000_0000h	11.4.1/244
4004_C018	Pin Control Register n (PORTD_PCR6)	32	R/W	0000_0000h	11.4.1/244
4004_C01C	Pin Control Register n (PORTD_PCR7)	32	R/W	0000_0000h	11.4.1/244
4004_C020	Pin Control Register n (PORTD_PCR8)	32	R/W	0000_0000h	11.4.1/244
4004_C024	Pin Control Register n (PORTD_PCR9)	32	R/W	0000_0000h	11.4.1/244
4004_C028	Pin Control Register n (PORTD_PCR10)	32	R/W	0000_0000h	11.4.1/244
4004_C02C	Pin Control Register n (PORTD_PCR11)	32	R/W	0000_0000h	11.4.1/244

Table continues on the next page...

PORT memory map (continued)

Absolute address (hex)	Register name	Width (in bits)	Access	Reset value	Section/page
4004_C030	Pin Control Register n (PORTD_PCR12)	32	R/W	0000_0000h	11.4.1/244
4004_C034	Pin Control Register n (PORTD_PCR13)	32	R/W	0000_0000h	11.4.1/244
4004_C038	Pin Control Register n (PORTD_PCR14)	32	R/W	0000_0000h	11.4.1/244
4004_C03C	Pin Control Register n (PORTD_PCR15)	32	R/W	0000_0000h	11.4.1/244
4004_C040	Pin Control Register n (PORTD_PCR16)	32	R/W	0000_0000h	11.4.1/244
4004_C044	Pin Control Register n (PORTD_PCR17)	32	R/W	0000_0000h	11.4.1/244
4004_C048	Pin Control Register n (PORTD_PCR18)	32	R/W	0000_0000h	11.4.1/244
4004_C04C	Pin Control Register n (PORTD_PCR19)	32	R/W	0000_0000h	11.4.1/244
4004_C050	Pin Control Register n (PORTD_PCR20)	32	R/W	0000_0000h	11.4.1/244
4004_C054	Pin Control Register n (PORTD_PCR21)	32	R/W	0000_0000h	11.4.1/244
4004_C058	Pin Control Register n (PORTD_PCR22)	32	R/W	0000_0000h	11.4.1/244
4004_C05C	Pin Control Register n (PORTD_PCR23)	32	R/W	0000_0000h	11.4.1/244
4004_C060	Pin Control Register n (PORTD_PCR24)	32	R/W	0000_0000h	11.4.1/244
4004_C064	Pin Control Register n (PORTD_PCR25)	32	R/W	0000_0000h	11.4.1/244
4004_C068	Pin Control Register n (PORTD_PCR26)	32	R/W	0000_0000h	11.4.1/244
4004_C06C	Pin Control Register n (PORTD_PCR27)	32	R/W	0000_0000h	11.4.1/244
4004_C070	Pin Control Register n (PORTD_PCR28)	32	R/W	0000_0000h	11.4.1/244
4004_C074	Pin Control Register n (PORTD_PCR29)	32	R/W	0000_0000h	11.4.1/244
4004_C078	Pin Control Register n (PORTD_PCR30)	32	R/W	0000_0000h	11.4.1/244
4004_C07C	Pin Control Register n (PORTD_PCR31)	32	R/W	0000_0000h	11.4.1/244
4004_C080	Global Pin Control Low Register (PORTD_GPCLR)	32	W (always reads zero)	0000_0000h	11.4.2/246
4004_C084	Global Pin Control High Register (PORTD_GPCHR)	32	W (always reads zero)	0000_0000h	11.4.3/247
4004_C0A0	Interrupt Status Flag Register (PORTD_ISFR)	32	w1c	0000_0000h	11.4.4/247
4004_C0C0	Digital Filter Enable Register (PORTD_DFER)	32	R/W	0000_0000h	11.4.5/248
4004_C0C4	Digital Filter Clock Register (PORTD_DFRCR)	32	R/W	0000_0000h	11.4.6/249
4004_C0C8	Digital Filter Width Register (PORTD_DFWR)	32	R/W	0000_0000h	11.4.7/249
4004_D000	Pin Control Register n (PORTE_PCR0)	32	R/W	0000_0000h	11.4.1/244
4004_D004	Pin Control Register n (PORTE_PCR1)	32	R/W	0000_0000h	11.4.1/244
4004_D008	Pin Control Register n (PORTE_PCR2)	32	R/W	0000_0000h	11.4.1/244
4004_D00C	Pin Control Register n (PORTE_PCR3)	32	R/W	0000_0000h	11.4.1/244

Table continues on the next page...

PORT memory map (continued)

Absolute address (hex)	Register name	Width (in bits)	Access	Reset value	Section/page
4004_D010	Pin Control Register n (PORTE_PCR4)	32	R/W	0000_0000h	11.4.1/244
4004_D014	Pin Control Register n (PORTE_PCR5)	32	R/W	0000_0000h	11.4.1/244
4004_D018	Pin Control Register n (PORTE_PCR6)	32	R/W	0000_0000h	11.4.1/244
4004_D01C	Pin Control Register n (PORTE_PCR7)	32	R/W	0000_0000h	11.4.1/244
4004_D020	Pin Control Register n (PORTE_PCR8)	32	R/W	0000_0000h	11.4.1/244
4004_D024	Pin Control Register n (PORTE_PCR9)	32	R/W	0000_0000h	11.4.1/244
4004_D028	Pin Control Register n (PORTE_PCR10)	32	R/W	0000_0000h	11.4.1/244
4004_D02C	Pin Control Register n (PORTE_PCR11)	32	R/W	0000_0000h	11.4.1/244
4004_D030	Pin Control Register n (PORTE_PCR12)	32	R/W	0000_0000h	11.4.1/244
4004_D034	Pin Control Register n (PORTE_PCR13)	32	R/W	0000_0000h	11.4.1/244
4004_D038	Pin Control Register n (PORTE_PCR14)	32	R/W	0000_0000h	11.4.1/244
4004_D03C	Pin Control Register n (PORTE_PCR15)	32	R/W	0000_0000h	11.4.1/244
4004_D040	Pin Control Register n (PORTE_PCR16)	32	R/W	0000_0000h	11.4.1/244
4004_D044	Pin Control Register n (PORTE_PCR17)	32	R/W	0000_0000h	11.4.1/244
4004_D048	Pin Control Register n (PORTE_PCR18)	32	R/W	0000_0000h	11.4.1/244
4004_D04C	Pin Control Register n (PORTE_PCR19)	32	R/W	0000_0000h	11.4.1/244
4004_D050	Pin Control Register n (PORTE_PCR20)	32	R/W	0000_0000h	11.4.1/244
4004_D054	Pin Control Register n (PORTE_PCR21)	32	R/W	0000_0000h	11.4.1/244
4004_D058	Pin Control Register n (PORTE_PCR22)	32	R/W	0000_0000h	11.4.1/244
4004_D05C	Pin Control Register n (PORTE_PCR23)	32	R/W	0000_0000h	11.4.1/244
4004_D060	Pin Control Register n (PORTE_PCR24)	32	R/W	0000_0000h	11.4.1/244
4004_D064	Pin Control Register n (PORTE_PCR25)	32	R/W	0000_0000h	11.4.1/244
4004_D068	Pin Control Register n (PORTE_PCR26)	32	R/W	0000_0000h	11.4.1/244
4004_D06C	Pin Control Register n (PORTE_PCR27)	32	R/W	0000_0000h	11.4.1/244
4004_D070	Pin Control Register n (PORTE_PCR28)	32	R/W	0000_0000h	11.4.1/244
4004_D074	Pin Control Register n (PORTE_PCR29)	32	R/W	0000_0000h	11.4.1/244
4004_D078	Pin Control Register n (PORTE_PCR30)	32	R/W	0000_0000h	11.4.1/244
4004_D07C	Pin Control Register n (PORTE_PCR31)	32	R/W	0000_0000h	11.4.1/244
4004_D080	Global Pin Control Low Register (PORTE_GPCLR)	32	W (always reads zero)	0000_0000h	11.4.2/246
4004_D084	Global Pin Control High Register (PORTE_GPCHR)	32	W (always reads zero)	0000_0000h	11.4.3/247

Table continues on the next page...

PORT memory map (continued)

Absolute address (hex)	Register name	Width (in bits)	Access	Reset value	Section/page
4004_D0A0	Interrupt Status Flag Register (PORTE_ISFR)	32	w1c	0000_0000h	11.4.4/247
4004_D0C0	Digital Filter Enable Register (PORTE_DFER)	32	R/W	0000_0000h	11.4.5/248
4004_D0C4	Digital Filter Clock Register (PORTE_DFCR)	32	R/W	0000_0000h	11.4.6/249
4004_D0C8	Digital Filter Width Register (PORTE_DFWR)	32	R/W	0000_0000h	11.4.7/249

11.4.1 Pin Control Register n (PORTx_PCRn)

For PCR1 to PCR5 of the port A, bit 0, 1, 6, 8, 9,10 reset to 1; for the PCR0 of the port A, bit 1, 6, 8, 9, 10 reset to 1; in other conditions, all bits reset to 0.

Addresses: 4004_9000h base + 0h offset + (4d × n), where n = 0d to 31d

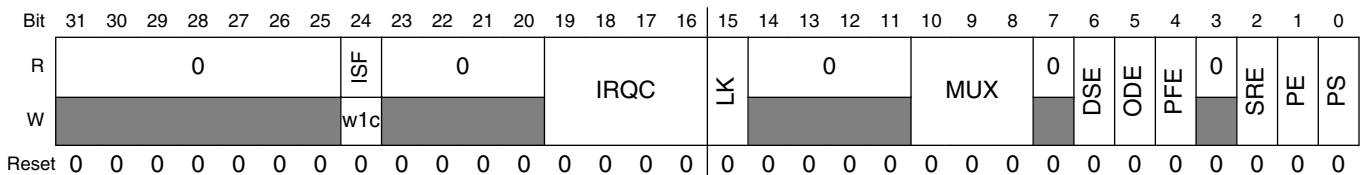

PORTx_PCRn field descriptions

Field	Description
31–25 Reserved	This read-only field is reserved and always has the value zero.
24 ISF	<p>Interrupt Status Flag</p> <p>The pin interrupt configuration is valid in all digital pin muxing modes.</p> <p>0 Configured interrupt has not been detected. 1 Configured interrupt has been detected. If pin is configured to generate a DMA request then the corresponding flag will be cleared automatically at the completion of the requested DMA transfer, otherwise the flag remains set until a logic one is written to that flag. If configured for a level sensitive interrupt that remains asserted then flag will set again immediately.</p>
23–20 Reserved	This read-only field is reserved and always has the value zero.
19–16 IRQC	<p>Interrupt Configuration</p> <p>The pin interrupt configuration is valid in all digital pin muxing modes. The corresponding pin is configured to generate interrupt / DMA Request as follows:</p> <p>0000 Interrupt/DMA Request disabled. 0001 DMA Request on rising edge. 0010 DMA Request on falling edge. 0011 DMA Request on either edge. 0100 Reserved. 1000 Interrupt when logic zero.</p>

Table continues on the next page...

PORTx_PCRn field descriptions (continued)

Field	Description
	1001 Interrupt on rising edge. 1010 Interrupt on falling edge. 1011 Interrupt on either edge. 1100 Interrupt when logic one. Others Reserved.
15 LK	Lock Register 0 Pin Control Register bits [15:0] are not locked. 1 Pin Control Register bits [15:0] are locked and cannot be updated until the next System Reset.
14–11 Reserved	This read-only field is reserved and always has the value zero.
10–8 MUX	Pin Mux Control The corresponding pin is configured as follows: 000 Pin Disabled (Analog). 001 Alternative 1 (GPIO). 010 Alternative 2 (chip specific). 011 Alternative 3 (chip specific). 100 Alternative 4 (chip specific). 101 Alternative 5 (chip specific). 110 Alternative 6 (chip specific). 111 Alternative 7 (chip specific / JTAG / NMI).
7 Reserved	This read-only field is reserved and always has the value zero.
6 DSE	Drive Strength Enable Drive Strength configuration is valid in all digital pin muxing modes. 0 Low drive strength is configured on the corresponding pin, if pin is configured as a digital output. 1 High drive strength is configured on the corresponding pin, if pin is configured as a digital output.
5 ODE	Open Drain Enable Open Drain configuration is valid in all digital pin muxing modes. 0 Open Drain output is disabled on the corresponding pin. 1 Open Drain output is enabled on the corresponding pin, provided pin is configured as a digital output.
4 PFE	Passive Filter Enable Passive Filter configuration is valid in all digital pin muxing modes. 0 Passive Input Filter is disabled on the corresponding pin. 1 Passive Input Filter is enabled on the corresponding pin, provided pin is configured as a digital input. A low pass filter (10 MHz to 30 MHz bandwidth) is enabled on the digital input path. Disable the Passive Input Filter when supporting high speed interfaces (> 2 MHz) on the pin.
3 Reserved	This read-only field is reserved and always has the value zero.

Table continues on the next page...

PORTx_PCRn field descriptions (continued)

Field	Description
2 SRE	<p>Slew Rate Enable</p> <p>Slew Rate configuration is valid in all digital pin muxing modes.</p> <p>0 Fast slew rate is configured on the corresponding pin, if pin is configured as a digital output. 1 Slow slew rate is configured on the corresponding pin, if pin is configured as a digital output.</p>
1 PE	<p>Pull Enable</p> <p>Pull configuration is valid in all digital pin muxing modes.</p> <p>0 Internal pull-up or pull-down resistor is not enabled on the corresponding pin. 1 Internal pull-up or pull-down resistor is enabled on the corresponding pin, provided pin is configured as a digital input.</p>
0 PS	<p>Pull Select</p> <p>Pull configuration is valid in all digital pin muxing modes.</p> <p>0 Internal pull-down resistor is enabled on the corresponding pin, if the corresponding Port Pull Enable Register bit is set. 1 Internal pull-up resistor is enabled on the corresponding pin, if the corresponding Port Pull Enable Register bit is set.</p>

11.4.2 Global Pin Control Low Register (PORTx_GPCLR)

Addresses: PORTA_GPCLR is 4004_9000h base + 80h offset = 4004_9080h

PORTB_GPCLR is 4004_A000h base + 80h offset = 4004_A080h

PORTC_GPCLR is 4004_B000h base + 80h offset = 4004_B080h

PORTD_GPCLR is 4004_C000h base + 80h offset = 4004_C080h

PORTE_GPCLR is 4004_D000h base + 80h offset = 4004_D080h

Bit	31	30	29	28	27	26	25	24	23	22	21	20	19	18	17	16	15	14	13	12	11	10	9	8	7	6	5	4	3	2	1	0
R	0																0															
W	GPWE																GPWD															
Reset	0	0	0	0	0	0	0	0	0	0	0	0	0	0	0	0	0	0	0	0	0	0	0	0	0	0	0	0	0	0	0	0

PORTx_GPCLR field descriptions

Field	Description
31–16 GPWE	<p>Global Pin Write Enable</p> <p>When set, causes bits [15:0] of the corresponding Pin Control Register (15 through 0) to update with the value in the Global Pin Write Data field.</p>
15–0 GPWD	<p>Global Pin Write Data</p> <p>Value to be written to bits [15:0] of all Pin Control Registers that are enabled by the Global Pin Write Enable field, provided the corresponding register has not been locked.</p>

11.4.3 Global Pin Control High Register (PORTx_GPCHR)

Addresses: PORTA_GPCHR is 4004_9000h base + 84h offset = 4004_9084h
 PORTB_GPCHR is 4004_A000h base + 84h offset = 4004_A084h
 PORTC_GPCHR is 4004_B000h base + 84h offset = 4004_B084h
 PORTD_GPCHR is 4004_C000h base + 84h offset = 4004_C084h
 PORTE_GPCHR is 4004_D000h base + 84h offset = 4004_D084h

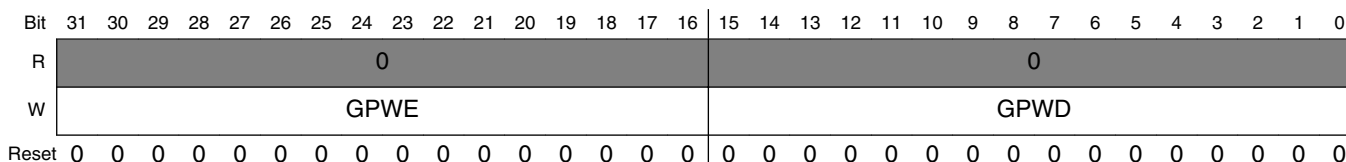

PORTx_GPCHR field descriptions

Field	Description
31–16 GPWE	Global Pin Write Enable When set, causes bits [15:0] of the corresponding Pin Control Register (31 through 16) to update with the value in the Global Pin Write Data field.
15–0 GPWD	Global Pin Write Data Value to be written to bits [15:0] of all Pin Control Registers that are enabled by the Global Pin Write Enable field, provided the corresponding register has not been locked.

11.4.4 Interrupt Status Flag Register (PORTx_ISFR)

The pin interrupt configuration is valid in all digital pin muxing modes. The Interrupt Status Flag for each pin is also visible in the corresponding Pin Control Register, and each flag can be cleared in either location.

Addresses: PORTA_ISFR is 4004_9000h base + A0h offset = 4004_90A0h
 PORTB_ISFR is 4004_A000h base + A0h offset = 4004_A0A0h
 PORTC_ISFR is 4004_B000h base + A0h offset = 4004_B0A0h
 PORTD_ISFR is 4004_C000h base + A0h offset = 4004_C0A0h
 PORTE_ISFR is 4004_D000h base + A0h offset = 4004_D0A0h

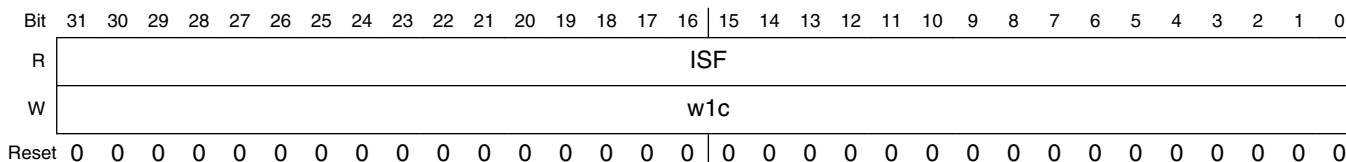

PORTx_ISFR field descriptions

Field	Description
31–0 ISF	<p>Interrupt Status Flag</p> <p>Each bit in the field indicates the detection of the configured interrupt of the same number as the bit.</p> <p>0 Configured interrupt has not been detected.</p> <p>1 Configured interrupt has been detected. If pin is configured to generate a DMA request then the corresponding flag will be cleared automatically at the completion of the requested DMA transfer, otherwise the flag remains set until a logic one is written to the flag. If configured for a level sensitive interrupt and the pin remains asserted then the flag will set again immediately after it is cleared.</p>

11.4.5 Digital Filter Enable Register (PORTx_DFER)

Addresses: PORTA_DFER is 4004_9000h base + C0h offset = 4004_90C0h
 PORTB_DFER is 4004_A000h base + C0h offset = 4004_A0C0h
 PORTC_DFER is 4004_B000h base + C0h offset = 4004_B0C0h
 PORTD_DFER is 4004_C000h base + C0h offset = 4004_C0C0h
 PORTE_DFER is 4004_D000h base + C0h offset = 4004_D0C0h

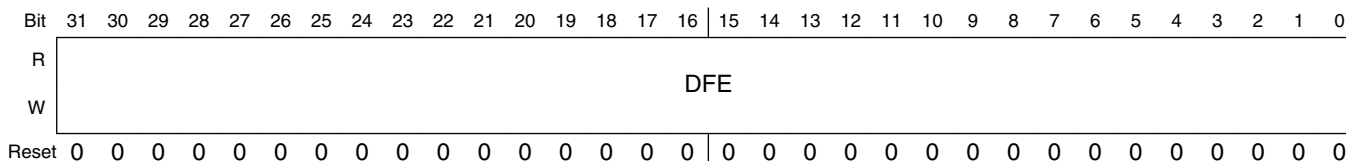

PORTx_DFER field descriptions

Field	Description
31–0 DFE	<p>Digital Filter Enable</p> <p>The digital filter configuration is valid in all digital pin muxing modes. The output of each digital filter is reset to zero at system reset and whenever the digital filter is disabled.</p> <p>0 Digital Filter is disabled on the corresponding pin and output of the digital filter is reset to zero. Each bit in the field enables the digital filter of the same number as the bit.</p> <p>1 Digital Filter is enabled on the corresponding pin, provided pin is configured as a digital input.</p>

11.4.6 Digital Filter Clock Register (PORTx_DFPCR)

Addresses: PORTA_DFPCR is 4004_9000h base + C4h offset = 4004_90C4h
 PORTB_DFPCR is 4004_A000h base + C4h offset = 4004_A0C4h
 PORTC_DFPCR is 4004_B000h base + C4h offset = 4004_B0C4h
 PORTD_DFPCR is 4004_C000h base + C4h offset = 4004_C0C4h
 PORTE_DFPCR is 4004_D000h base + C4h offset = 4004_D0C4h

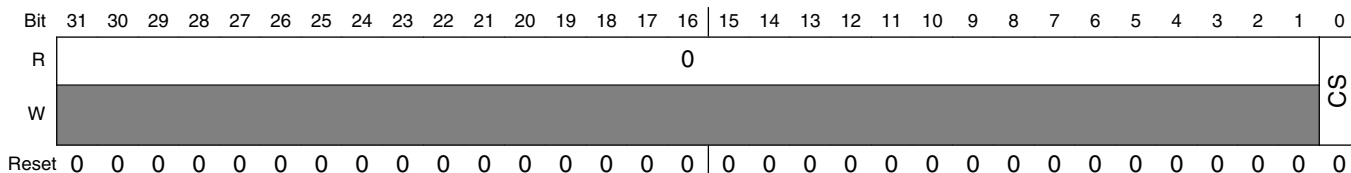

PORTx_DFPCR field descriptions

Field	Description
31–1 Reserved	This read-only field is reserved and always has the value zero.
0 CS	<p>Clock Source</p> <p>The digital filter configuration is valid in all digital pin muxing modes. Configures the clock source for the digital input filters. Changing the filter clock source should only be done after disabling all enabled digital filters.</p> <p>0 Digital Filters are clocked by the bus clock. 1 Digital Filters are clocked by the 1 kHz LPO clock.</p>

11.4.7 Digital Filter Width Register (PORTx_DFWR)

The digital filter configuration is valid in all digital pin muxing modes.

Addresses: PORTA_DFWR is 4004_9000h base + C8h offset = 4004_90C8h
 PORTB_DFWR is 4004_A000h base + C8h offset = 4004_A0C8h
 PORTC_DFWR is 4004_B000h base + C8h offset = 4004_B0C8h
 PORTD_DFWR is 4004_C000h base + C8h offset = 4004_C0C8h
 PORTE_DFWR is 4004_D000h base + C8h offset = 4004_D0C8h

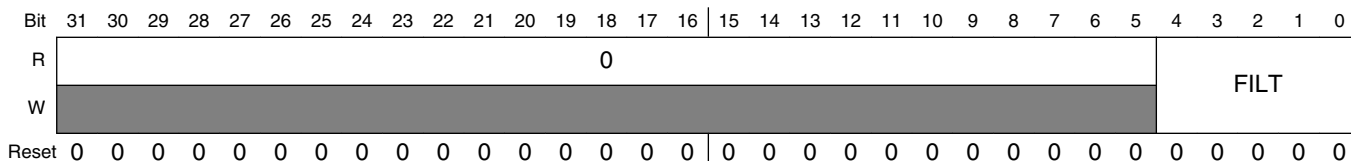

PORTx_DFWR field descriptions

Field	Description
31–5 Reserved	This read-only field is reserved and always has the value zero.
4–0 FILT	<p>Filter Length</p> <p>The digital filter configuration is valid in all digital pin muxing modes. Configures the maximum size of the glitches (in clock cycles) the digital filter absorbs for enabled digital filters. Glitches that are longer than this register setting (in clock cycles) will pass through the digital filter, while glitches that are equal to or less than this register setting (in clock cycles) will be filtered. Changing the filter length should only be done after disabling all enabled filters.</p>

11.5 Functional description

11.5.1 Pin control

The lower half of the pin control register configures the following functions for each pin within the 32-bit port. These functions apply across all digital pin muxing modes and individual peripherals do not override the configuration in this register (for example, if an I²C function is enabled on a pin then that does not override the pullup or open drain configuration for that pin).

When the pin muxing mode is configured for analog/disabled then the all digital functions on that pin are disabled. This includes the pullup and pulldown enables, digital output buffer enable, digital input buffer enable and passive filter enable.

- Pullup or pulldown enable
- Drive strength and slew rate configuration
- Open drain enable
- Passive input filter enable
- Pin muxing mode

A lock bit also exists that allows the configuration for each pin to be locked until the next system reset. Once locked, writes to the lower half of that pin control register are ignored, although a bus error is not generated on an attempted write to a locked register.

The configuration of each pin control register is retained when the PORT module is disabled.

11.5.2 Global pin control

The two global pin control registers allow a single register write to update the lower half of the pin control register on up to sixteen pins, all with the same value. Registers that are locked cannot be written using the global pin control registers.

The global pin control registers are designed to enable software to quickly configure multiple pins within the one port for the same peripheral function. Note however that interrupt functions are unable to be configured using the global pin control registers.

The global pin control registers are write only registers, that always read as zero.

11.5.3 External interrupts

The external interrupt capability of the PORT module are available in all digital pin muxing modes provided the PORT module is enabled.

Each pin can be individually configured for any of the following external interrupt modes:

- Interrupt disabled (default out of reset)
- Active high level sensitive interrupt
- Active low level sensitive interrupt
- Rising edge sensitive interrupt
- Falling edge sensitive interrupt
- Rising and falling edge sensitive interrupt
- Rising edge sensitive DMA request
- Falling edge sensitive DMA request
- Rising and falling edge sensitive DMA request

The interrupt status flag is set when the configured edge or level is detected on the output of the digital filter (if enabled) or pin (if digital filter is bypassed). When not in stop mode, the input is first synchronized to the bus clock to detect the configured level or edge transition.

The PORT module generates a single interrupt that asserts when the interrupt status flag is set for any enabled interrupt for that port. The interrupt negates once the interrupt status flags for all enabled interrupts have been cleared.

The PORT module generates a single DMA request that asserts when the interrupt status flag is set for any enabled DMA request in that port. The DMA request negates once the DMA transfer has been completed, since that clears the interrupt status flags for all enabled DMA requests.

During stop mode, the interrupt status flag for any enabled interrupt (but not DMA request) will asynchronously set if the required level or edge is detected. This also generates an asynchronous wakeup signal to exit the low power mode.

11.5.4 Digital filter

The digital filter capabilities of the PORT module are available in all digital pin muxing modes provided the PORT module is enabled.

The clock used for all digital filters within the one port can be configured between the bus clock or the 1 kHz LPO clock. This selection should be changed only when all digital filters for that port are disabled. If the digital filters for a port are configured to use the bus clock, then the digital filters are bypassed (and do not update) during stop mode.

The filter width in clock size is the same for all enabled digital filters within the one port and should be changed only when all digital filters for that port are disabled.

The output of each digital filter is logic zero after system reset and whenever a digital filter is disabled. Once a digital filter is enabled, the input is synchronized to the filter clock (either the bus clock or the 1 kHz LPO clock). If the synchronized input and the output of the digital filter remain different for a number of filter clock cycles equal to the filter width register configuration, then the output of the digital filter updates to equal the synchronized filter input.

The minimum latency through a digital filter equals two or three filter clock cycles plus the filter width configuration register.

Chapter 12

System integration module (SIM)

12.1 Introduction

NOTE

For the chip-specific implementation details of this module's instances see the chip configuration chapter.

The system integration module (SIM) provides system control and chip configuration registers.

12.1.1 Features

- Configuration for system clocking
 - Clock source selection for SDHC, I²S, USB, and PLL/FLL source
 - System clock divide values
 - I²S and USB clock divide values
- Architectural clock gating control
- Flash configuration
- USB regulator configuration
- RAM size configuration
- Flextimer external clock and fault source selection
- UART0 and UART1 receive/transmit source selection/configuration
- Reset pin filtering

12.1.2 Modes of operation

- Run mode
- Sleep mode
- Deep sleep mode
- VLLS mode

12.1.3 SIM Signal Descriptions

Table 12-1. SIM Signal Descriptions

Signal	Description	I/O
EZP_CS	EzPort mode select	I

12.1.3.1 Detailed signal description

Table 12-2. SIM interface-detailed signal descriptions

Signal	I/O	Description
EZP_CS	I	EZPORT mode select
		State meaning
		Timing

		Assertion-0 - Configure part for EZPORT mode
		Negation- 1 - Configure part for normal flash operation
		As a mode select, this signal is only recognized during reset although it can be asserted and negated at any time.
		Assertion-May occur at any time; input may be asserted asynchronously to the system clock.
		Negation-May occur at any time; input may be negated asynchronously to the system clock.

12.2 Memory map and register definition

The SIM module contains many bitfields for selecting the clock source and dividers for various module clocks. See the [Clock Distribution](#) chapter for more information including block diagrams and clock definitions.

NOTE

The SIM_SOPT1 register is located at a different base address than the other SIM registers.

SIM memory map

Absolute address (hex)	Register name	Width (in bits)	Access	Reset value	Section/page
4004_7000	System Options Register 1 (SIM_SOPT1)	32	R/W	Undefined	12.2.1/256
4004_8004	System Options Register 2 (SIM_SOPT2)	32	R/W	0000_1000h	12.2.2/258
4004_800C	System Options Register 4 (SIM_SOPT4)	32	R/W	0000_0000h	12.2.3/260
4004_8010	System Options Register 5 (SIM_SOPT5)	32	R/W	0000_0000h	12.2.4/262
4004_8014	System Options Register 6 (SIM_SOPT6)	32	R/W	0000_0000h	12.2.5/264
4004_8018	System Options Register 7 (SIM_SOPT7)	32	R/W	0000_0000h	12.2.6/265
4004_8024	System Device Identification Register (SIM_SDID)	32	R	Undefined	12.2.7/267
4004_8028	System Clock Gating Control Register 1 (SIM_SCGC1)	32	R/W	0000_0000h	12.2.8/268
4004_802C	System Clock Gating Control Register 2 (SIM_SCGC2)	32	R/W	0000_0000h	12.2.9/269
4004_8030	System Clock Gating Control Register 3 (SIM_SCGC3)	32	R/W	0000_0000h	12.2.10/270
4004_8034	System Clock Gating Control Register 4 (SIM_SCGC4)	32	R/W	6010_0030h	12.2.11/271
4004_8038	System Clock Gating Control Register 5 (SIM_SCGC5)	32	R/W	0004_0180h	12.2.12/274
4004_803C	System Clock Gating Control Register 6 (SIM_SCGC6)	32	R/W	4000_0001h	12.2.13/276
4004_8040	System Clock Gating Control Register 7 (SIM_SCGC7)	32	R/W	0000_0007h	12.2.14/278
4004_8044	System Clock Divider Register 1 (SIM_CLKDIV1)	32	R/W	Undefined	12.2.15/279
4004_8048	System Clock Divider Register 2 (SIM_CLKDIV2)	32	R/W	0000_0000h	12.2.16/281
4004_804C	Flash Configuration Register 1 (SIM_FCFG1)	32	R	Undefined	12.2.17/282
4004_8050	Flash Configuration Register 2 (SIM_FCFG2)	32	R	Undefined	12.2.18/284
4004_8054	Unique Identification Register High (SIM_UIDH)	32	R	Undefined	12.2.19/285
4004_8058	Unique Identification Register Mid-High (SIM_UIDMH)	32	R	Undefined	12.2.20/286
4004_805C	Unique Identification Register Mid Low (SIM_UIDML)	32	R	Undefined	12.2.21/286
4004_8060	Unique Identification Register Low (SIM_UIDL)	32	R	Undefined	12.2.22/287

12.2.1 System Options Register 1 (SIM_SOPT1)

The reset value of the SOPT1 register is as follows: Exit from POR and LVD: USBREGEN is set, USBSTBY is cleared, and OSC32KSEL is cleared. Exit from VLLS or other system reset: USBREGEN, USBSTBY and OSC32KSEL are unaffected

Address: SIM_SOPT1 is 4004_7000h base + 0h offset = 4004_7000h

Bit	31	30	29	28	27	26	25	24	23	22	21	20	19	18	17	16
R	USBREGEN	USBSTBY	Reserved			0			MS	0			OSC32KSEL	0		
W			Reserved			Reserved				Reserved				Reserved		
Reset	x*	x*	x*	x*	x*	x*	x*	x*	x*	x*	x*	x*	x*	x*	x*	x*
Bit	15	14	13	12	11	10	9	8	7	6	5	4	3	2	1	0
R	RAMSIZE				0											
W	Reserved															
Reset	x*	x*	x*	x*	x*	x*	x*	x*	x*	x*	x*	x*	x*	x*	x*	x*

* Notes:

- x = Undefined at reset.

SIM_SOPT1 field descriptions

Field	Description
31 USBREGEN	USB voltage regulator enable Controls whether the USB voltage regulator is enabled. 0 USB voltage regulator is disabled. 1 USB voltage regulator is enabled.
30 USBSTBY	USB voltage regulator in standby mode Controls whether the USB voltage regulator is placed in standby mode. 0 USB voltage regulator not in standby. 1 USB voltage regulator in standby.
29–27 Reserved	This field is reserved.
26–24 Reserved	This read-only field is reserved and always has the value zero.
23 MS	EzPort chip select pin state Reflects the state of the EzPort chip select ($\overline{\text{EZP_CS}}$) pin during the last reset. This bit is read-only.

Table continues on the next page...

SIM_SOPT1 field descriptions (continued)

Field	Description
22–20 Reserved	This read-only field is reserved and always has the value zero.
19 OSC32KSEL	32K oscillator clock select Selects the 32 kHz clock source (ERCLK32K) for Segment LCD, TSI, and LPTMR. This bit is reset only for POR/LVD. 0 System oscillator (OSC32KCLK) 1 RTC oscillator
18–16 Reserved	This read-only field is reserved and always has the value zero.
15–12 RAMSIZE	RAM size This field specifies the amount of system RAM available on the device. 0000 Undefined 0001 Undefined 0010 Undefined 0011 Undefined 0100 Undefined 0101 32 KBytes 0110 Undefined 0111 64 KBytes 1000 96 KBytes 1001 128 KBytes 1010 Undefined 1011 Undefined 1100 Undefined 1101 Undefined 1110 Undefined 1111 Undefined
11–0 Reserved	This read-only field is reserved and always has the value zero.

12.2.2 System Options Register 2 (SIM_SOPT2)

SOPT2 contains the controls for selecting many of the module clock source options on this device. See the Clock Distribution chapter for more information including clocking diagrams and definitions of device clocks.

Address: SIM_SOPT2 is 4004_7000h base + 1004h offset = 4004_8004h

Bit	31	30	29	28	27	26	25	24	23	22	21	20	19	18	17	16
R	0		SDHCSRC		0		I2SSRC		0	0	0	0	0	0	0	0
W	[Grey]		SDHCSRC		[Grey]		I2SSRC		[Grey]	[Grey]	[Grey]	[Grey]	USBSRC	[Grey]	PLLFLLSEL	
Reset	0	0	0	0	0	0	0	0	0	0	0	0	0	0	0	0
Bit	15	14	13	12	11	10	9	8	7	6	5	4	3	2	1	0
R	0		TRACECLKSEL	CMTUARTPAD	0	0	0				0		MCGCLKSEL			
W	[Grey]		TRACECLKSEL	CMTUARTPAD	[Grey]	[Grey]	[Grey]	[Grey]	[Grey]	[Grey]	[Grey]	[Grey]	[Grey]	[Grey]	[Grey]	MCGCLKSEL
Reset	0	0	0	1	0	0	0	0	0	0	0	0	0	0	0	0

SIM_SOPT2 field descriptions

Field	Description
31–30 Reserved	This read-only field is reserved and always has the value zero.
29–28 SDHCSRC	SDHC clock source select Selects the clock source for the SDHC clock. 00 Core/system clock. 01 MCGPLLCLK/MCGFLLCLK clock 10 OSCERCLK clock 11 External bypass clock (SDHC0_CLKIN)
27–26 Reserved	This read-only field is reserved and always has the value zero.
25–24 I2SSRC	I2S master clock source select Selects the clock source for I ² S master clock. 00 Core/system clock divided by the I ² S fractional clock divider. See the SIM_CLKDIV2[I2SFRAC, I2SDIV] descriptions. 01 MCGPLLCLK/MCGFLLCLK clock divided by the I ² S fractional clock divider. See the SIM_CLKDIV2[I2SFRAC, I2SDIV] descriptions.

Table continues on the next page...

SIM_SOPT2 field descriptions (continued)

Field	Description
	10 OSCERCLK clock 11 External bypass clock (I2S0_CLKIN)
23–22 Reserved	This read-only field is reserved and always has the value zero.
21–20 Reserved	This read-only field is reserved and always has the value zero.
19 Reserved	This read-only field is reserved and always has the value zero.
18 USBSRC	USB clock source select Selects the clock source for the USB 48 MHz clock. 0 External bypass clock (USB_CLKIN). 1 MCGPLLCLK/MCGFLLCLK clock divided by the USB fractional divider. See the SIM_CLKDIV2[USBFRAC, USBDIV] descriptions.
17 Reserved	This read-only field is reserved and always has the value zero.
16 PLLFLSEL	PLL/FLL clock select Selects the MCGPLLCLK or MCGFLLCLK clock for various peripheral clocking options. 0 MCGFLLCLK clock 1 MCGPLLCLK clock
15–13 Reserved	This read-only field is reserved and always has the value zero.
12 TRACECLKSEL	Debug trace clock select Selects the core/system clock or MCG output clock (MCGOUTCLK) as the trace clock source. 0 MCGOUTCLK 1 Core/system clock
11 CMTUARTPAD	CMT/UART pad drive strength Controls the output drive strength of the CMT IRO signal or UART0_TXD signal on PTD7 pin by selecting either one or two pads to drive it. 0 Single-pad drive strength for CMT IRO or UART0_TXD. 1 Dual-pad drive strength for CMT IRO or UART0_TXD.
10 Reserved	This read-only field is reserved and always has the value zero.
9–8 Reserved	This read-only field is reserved and always has the value zero.
7–1 Reserved	This read-only field is reserved and always has the value zero.
0 MCGCLKSEL	MCG clock select Selects the MCG's external reference clock.

Table continues on the next page...

SIM_SOPT2 field descriptions (continued)

Field	Description
0	System oscillator (OSCCLK)
1	32 kHz RTC oscillator

12.2.3 System Options Register 4 (SIM_SOPT4)

Address: SIM_SOPT4 is 4004_7000h base + 100Ch offset = 4004_800Ch

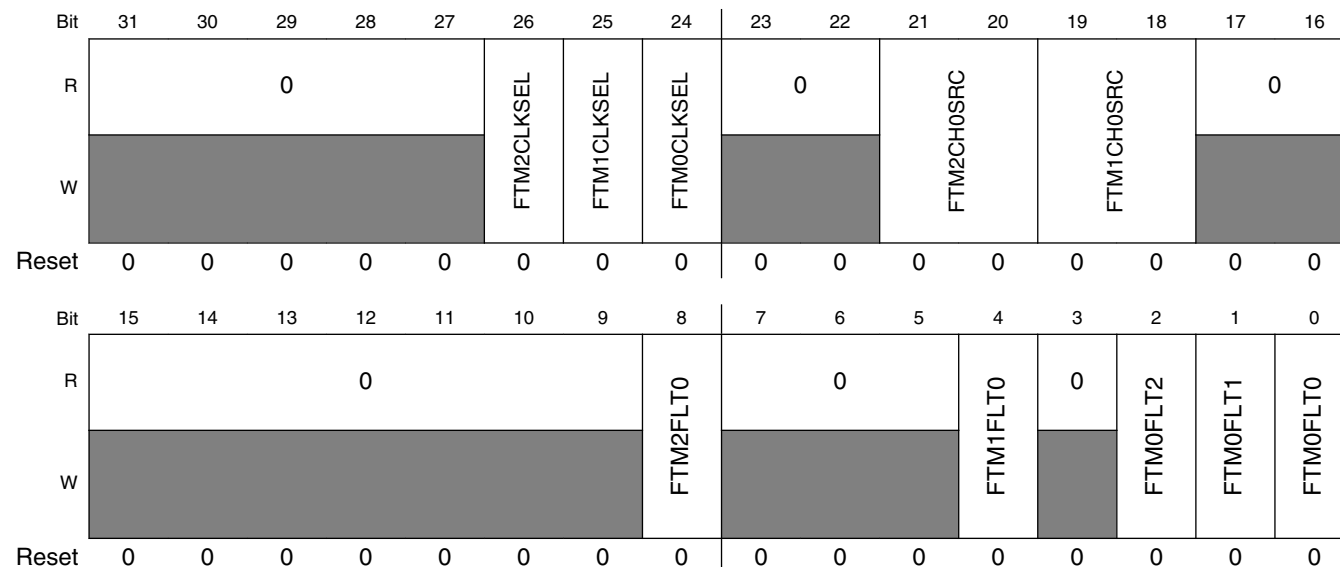

SIM_SOPT4 field descriptions

Field	Description
31–27 Reserved	This read-only field is reserved and always has the value zero.
26 FTM2CLKSEL	FlexTimer 2 External Clock Pin Select Selects the external pin used to drive the clock to the FTM2 module. NOTE: The selected pin must also be configured for the FTM2 module external clock function through the appropriate pin control register in the port control module. 0 FTM2 external clock driven by FTM_CLK0 pin. 1 FTM2 external clock driven by FTM_CLK1 pin.
25 FTM1CLKSEL	FTM1 External Clock Pin Select Selects the external pin used to drive the clock to the FTM1 module. NOTE: The selected pin must also be configured for the FTM external clock function through the appropriate pin control register in the port control module. 0 FTM_CLK0 pin 1 FTM_CLK1 pin

Table continues on the next page...

SIM_SOPT4 field descriptions (continued)

Field	Description
24 FTM0CLKSEL	FlexTimer 0 External Clock Pin Select Selects the external pin used to drive the clock to the FTM0 module. NOTE: The selected pin must also be configured for the FTM external clock function through the appropriate pin control register in the port control module. 0 FTM_CLK0 pin 1 FTM_CLK1 pin
23–22 Reserved	This read-only field is reserved and always has the value zero.
21–20 FTM2CH0SRC	FTM2 channel 0 input capture source select Selects the source for FTM2 channel 0 input capture. NOTE: When the FTM is not in input capture mode, clear this field. 00 FTM2_CH0 signal 01 CMP0 output 10 CMP1 output 11 Reserved
19–18 FTM1CH0SRC	FTM1 channel 0 input capture source select Selects the source for FTM1 channel 0 input capture. NOTE: When the FTM is not in input capture mode, clear this field. 00 FTM1_CH0 signal 01 CMP0 output 10 CMP1 output 11 Reserved
17–9 Reserved	This read-only field is reserved and always has the value zero.
8 FTM2FLT0	FTM2 Fault 0 Select Selects the source of FTM2 fault 0. NOTE: The pin source for fault 0 must be configured for the FTM module fault function through the appropriate PORTx pin control register. 0 FTM2_FLT0 pin 1 CMP0 out
7–5 Reserved	This read-only field is reserved and always has the value zero.
4 FTM1FLT0	FTM1 Fault 0 Select Selects the source of FTM1 fault 0. NOTE: The pin source for fault 0 must be configured for the FTM module fault function through the appropriate pin control register in the port control module.

Table continues on the next page...

SIM_SOPT4 field descriptions (continued)

Field	Description
	0 FTM1_FLT0 pin 1 CMP0 out
3 Reserved	This read-only field is reserved and always has the value zero.
2 FTM0FLT2	FTM0 Fault 2 Select Selects the source of FTM0 fault 2. NOTE: The pin source for fault 2 must be configured for the FTM module fault function through the appropriate pin control register in the port control module. 0 FTM0_FLT2 pin 1 CMP2 out
1 FTM0FLT1	FTM0 Fault 1 Select Selects the source of FTM0 fault 1. NOTE: The pin source for fault 1 must be configured for the FTM module fault function through the appropriate pin control register in the port control module. 0 FTM0_FLT1 pin 1 CMP1 out
0 FTM0FLT0	FTM0 Fault 0 Select Selects the source of FTM0 fault 0. NOTE: The pin source for fault 0 must be configured for the FTM module fault function through the appropriate pin control register in the port control module. 0 FTM0_FLT0 pin 1 CMP0 out

12.2.4 System Options Register 5 (SIM_SOPT5)

Address: SIM_SOPT5 is 4004_7000h base + 1010h offset = 4004_8010h

Bit	31	30	29	28	27	26	25	24	23	22	21	20	19	18	17	16
R	0															
W	[Shaded]															
Reset	0	0	0	0	0	0	0	0	0	0	0	0	0	0	0	0
Bit	15	14	13	12	11	10	9	8	7	6	5	4	3	2	1	0
R	0								UART1RXSRC	UARTTXSRC	UART0RXSRC	UART0TXSRC				
W	[Shaded]								UART1RXSRC	UARTTXSRC	UART0RXSRC	UART0TXSRC				
Reset	0	0	0	0	0	0	0	0	0	0	0	0	0	0	0	0

SIM_SOPT5 field descriptions

Field	Description
31–8 Reserved	This read-only field is reserved and always has the value zero.
7–6 UART1RXSRC	UART 1 receive data source select Selects the source for the UART 1 receive data. 00 UART1_RX pin 01 CMP0 10 CMP1 11 Reserved
5–4 UARTTXSRC	UART 1 transmit data source select Selects the source for the UART 1 transmit data. 00 UART1_TX pin 01 UART1_TX pin modulated with FTM1 channel 0 output 10 UART1_TX pin modulated with FTM2 channel 0 output 11 Reserved
3–2 UART0RXSRC	UART 0 receive data source select Selects the source for the UART 0 receive data. 00 UART0_RX pin 01 CMP0 10 CMP1 11 Reserved
1–0 UART0TXSRC	UART 0 transmit data source select Selects the source for the UART 0 transmit data. 00 UART0_TX pin 01 UART0_TX pin modulated with FTM1 channel 0 output 10 UART0_TX pin modulated with FTM2 channel 0 output 11 Reserved

12.2.5 System Options Register 6 (SIM_SOPT6)

The reset values of the RSTFLTEN and RSTFLTSEL bits are for power-on reset only. They are unaffected by other reset types.

Address: SIM_SOPT6 is 4004_7000h base + 1014h offset = 4004_8014h

Bit	31	30	29	28	27	26	25	24	23	22	21	20	19	18	17	16								
R	RSTFLTEN								RSTFLTSEL								0							
W																								
Reset	0	0	0	0	0	0	0	0	0	0	0	0	0	0	0	0								
Bit	15	14	13	12	11	10	9	8	7	6	5	4	3	2	1	0								
R	0																							
W																								
Reset	0	0	0	0	0	0	0	0	0	0	0	0	0	0	0	0								

SIM_SOPT6 field descriptions

Field	Description
31–29 RSTFLTEN	<p>Reset pin filter enable</p> <p>Selects how the reset pin filter is enabled. See Reset pin filter for more details.</p> <p>000 All filtering disabled 001 Bus clock filter enabled in normal operation. LPO clock filter enabled in stop mode. 010 LPO clock filter enabled 011 Bus clock filter enabled in normal operation. All filtering disabled in stop mode. 100 LPO clock filter enabled in normal operation. All filtering disabled in stop mode. 101 Reserved (all filtering disabled) 110 Reserved (all filtering disabled) 111 Reserved (all filtering disabled)</p>
28–24 RSTFLTSEL	<p>Reset pin filter select</p> <p>Selects the reset pin bus clock filter count value. The filter count value is the RSTFL value + 1.</p>
23–0 Reserved	<p>This read-only field is reserved and always has the value zero.</p>

12.2.6 System Options Register 7 (SIM_SOPT7)

Address: SIM_SOPT7 is 4004_7000h base + 1018h offset = 4004_8018h

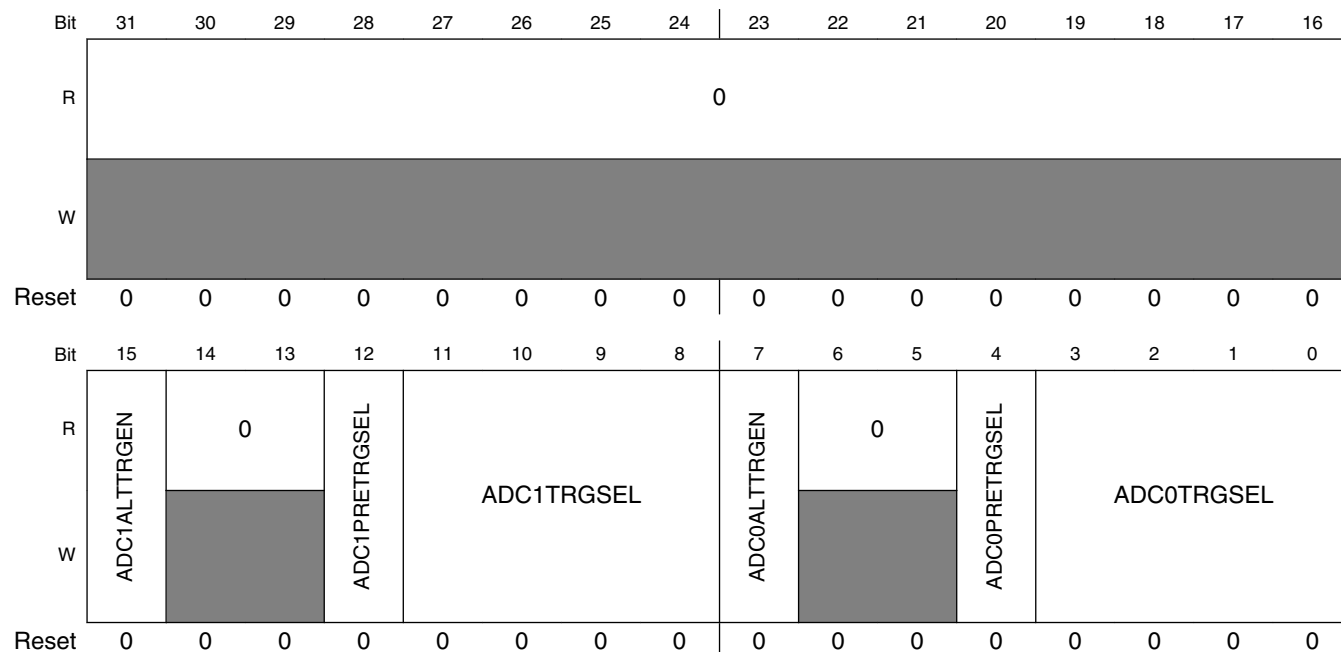

SIM_SOPT7 field descriptions

Field	Description
31–16 Reserved	This read-only field is reserved and always has the value zero.
15 ADC1ALTTRGEN	ADC1 alternate trigger enable Enable alternative conversion triggers for ADC1. 0 PDB trigger selected for ADC1 1 Alternate trigger selected for ADC1 as defined by ADC1TRGSEL.
14–13 Reserved	This read-only field is reserved and always has the value zero.
12 ADC1PRETRGSEL	ADC1 pre-trigger select Selects the ADC1 pre-trigger source when alternative triggers are enabled through ADC1ALTTRGEN. 0 Pre-trigger A selected for ADC1. 1 Pre-trigger B selected for ADC1.
11–8 ADC1TRGSEL	ADC1 trigger select Selects the ADC1 trigger source when alternative triggers are functional. NOTE: Not all trigger sources are available in Stop and VLPS modes. 0000 PDB external trigger pin input (PDB0_EXTRG)

Table continues on the next page...

SIM_SOPT7 field descriptions (continued)

Field	Description
	0001 High speed comparator 0 output 0010 High speed comparator 1 output 0011 High speed comparator 2 output 0100 PIT trigger 0 0101 PIT trigger 1 0110 PIT trigger 2 0111 PIT trigger 3 1000 FTM0 trigger 1001 FTM1 trigger 1010 FTM2 trigger 1011 Unused 1100 RTC alarm 1101 RTC seconds 1110 Low-power timer trigger 1011 Unused
7 ADC0ALTTTRGEN	ADC0 alternate trigger enable Enable alternative conversion triggers for ADC0. 0 PDB trigger selected for ADC0. 1 Alternate trigger selected for ADC0.
6–5 Reserved	This read-only field is reserved and always has the value zero.
4 ADC0PRETRGSEL	ADC0 pretrigger select Selects the ADC0 pre-trigger source when alternative triggers are enabled through ADC0ALTTTRGEN. 0 Pre-trigger A 1 Pre-trigger B
3–0 ADC0TRGSEL	ADC0 trigger select Selects the ADC0 trigger source when alternative triggers are functional. NOTE: Not all trigger sources are available in Stop and VLPS modes. . 0000 PDB external trigger pin input (PDB0_EXTRG) 0001 High speed comparator 0 output 0010 High speed comparator 1 output 0011 High speed comparator 2 output 0100 PIT trigger 0 0101 PIT trigger 1 0110 PIT trigger 2 0111 PIT trigger 3 1000 FTM0 trigger 1001 FTM1 trigger 1010 FTM2 trigger 1011 Unused 1100 RTC alarm

Table continues on the next page...

SIM_SOPT7 field descriptions (continued)

Field	Description
1101	RTC seconds
1110	Low-power timer trigger
1011	Unused

12.2.7 System Device Identification Register (SIM_SDID)

Address: SIM_SDID is 4004_7000h base + 1024h offset = 4004_8024h

Bit	31	30	29	28	27	26	25	24	23	22	21	20	19	18	17	16	15	14	13	12	11	10	9	8	7	6	5	4	3	2	1	0																
R	0																REVID				0	0	1	0	FAMID				PINID																			
W	[Greyed out]																																															
Reset	x*	x*	x*	x*	x*	x*	x*	x*	x*	x*	x*	x*	x*	x*	x*	x*	x*	x*	x*	x*	x*	x*	x*	x*	x*	x*	x*	x*	x*	x*	x*	x*	x*	x*	x*	x*	x*	x*	x*	x*	x*	x*	x*	x*	x*	x*	x*	x*

* Notes:

- x = Undefined at reset.

SIM_SDID field descriptions

Field	Description
31–16 Reserved	This read-only field is reserved and always has the value zero.
15–12 REVID	Device revision number Specifies the silicon implementation number for the device.
11–10 Reserved	This read-only field is reserved and always has the value zero.
9 Reserved	This read-only field is reserved and always has the value zero.
8 Reserved	This read-only field is reserved and always has the value one.
7 Reserved	This read-only field is reserved and always has the value zero.
6–4 FAMID	Kinetis family identification Specifies the Kinetis family of the device. 000 K10 001 K20 010 K30 011 K40 100 K60 101 K70 110 K50 and K52 111 K51 and K53

Table continues on the next page...

SIM_SDID field descriptions (continued)

Field	Description
3–0 PINID	<p>Pincount identification</p> <p>Specifies the pincount of the device.</p> <p>0000 Reserved 0001 Reserved 0010 32-pin 0011 Reserved 0100 48-pin 0101 64-pin 0110 80-pin 0111 81-pin 1000 100-pin 1001 121-pin 1010 144-pin 1011 Reserved 1100 196-pin 1101 Reserved 1110 256-pin 1111 Reserved</p>

12.2.8 System Clock Gating Control Register 1 (SIM_SCGC1)

Address: SIM_SCGC1 is 4004_7000h base + 1028h offset = 4004_8028h

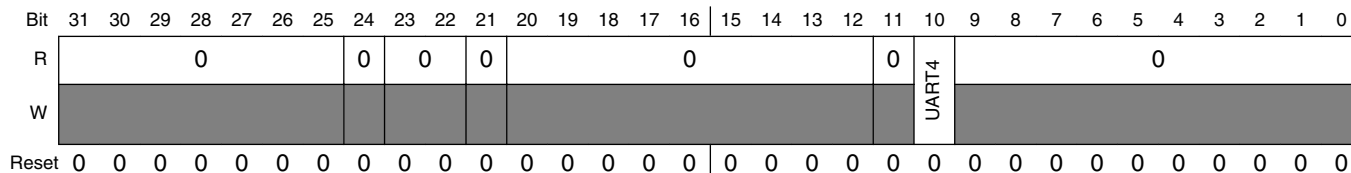

SIM_SCGC1 field descriptions

Field	Description
31–25 Reserved	This read-only field is reserved and always has the value zero.
24 Reserved	This read-only field is reserved and always has the value zero.
23–22 Reserved	This read-only field is reserved and always has the value zero.
21 Reserved	This read-only field is reserved and always has the value zero.
20–12 Reserved	This read-only field is reserved and always has the value zero.

Table continues on the next page...

SIM_SCGC1 field descriptions (continued)

Field	Description
11 Reserved	This read-only field is reserved and always has the value zero.
10 UART4	UART4 Clock Gate Control This bit controls the clock gate to the UART4 module. 0 Clock disabled 1 Clock enabled
9–0 Reserved	This read-only field is reserved and always has the value zero.

12.2.9 System Clock Gating Control Register 2 (SIM_SCGC2)

Address: SIM_SCGC2 is 4004_7000h base + 102Ch offset = 4004_802Ch

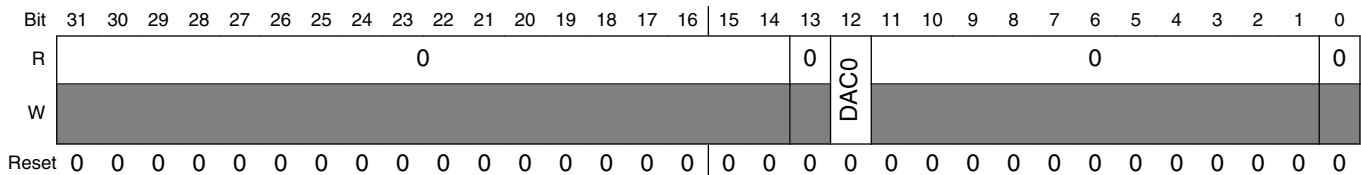

SIM_SCGC2 field descriptions

Field	Description
31–14 Reserved	This read-only field is reserved and always has the value zero.
13 Reserved	This read-only field is reserved and always has the value zero.
12 DAC0	DAC0 Clock Gate Control This bit controls the clock gate to the DAC0 module. 0 Clock disabled 1 Clock enabled
11–1 Reserved	This read-only field is reserved and always has the value zero.
0 Reserved	This read-only field is reserved and always has the value zero.

12.2.10 System Clock Gating Control Register 3 (SIM_SCGC3)

Address: SIM_SCGC3 is 4004_7000h base + 1030h offset = 4004_8030h

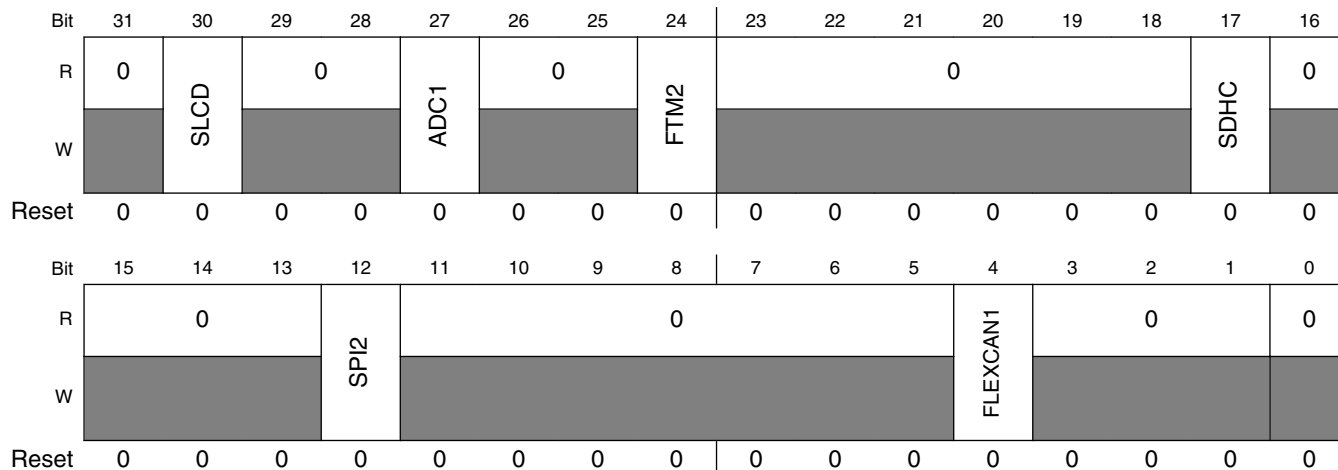

SIM_SCGC3 field descriptions

Field	Description
31 Reserved	This read-only field is reserved and always has the value zero.
30 SLCD	Segment LCD Clock Gate Control This bit controls the clock gate to the Segment LCD module. 0 Clock disabled 1 Clock enabled
29–28 Reserved	This read-only field is reserved and always has the value zero.
27 ADC1	ADC1 Clock Gate Control This bit controls the clock gate to the ADC1 module. 0 Clock disabled 1 Clock enabled
26–25 Reserved	This read-only field is reserved and always has the value zero.
24 FTM2	FTM2 Clock Gate Control This bit controls the clock gate to the FTM2 module. 0 Clock disabled 1 Clock enabled
23–18 Reserved	This read-only field is reserved and always has the value zero.

Table continues on the next page...

SIM_SCGC3 field descriptions (continued)

Field	Description
17 SDHC	SDHC Clock Gate Control This bit controls the clock gate to the SDHC module. 0 Clock disabled 1 Clock enabled
16–13 Reserved	This read-only field is reserved and always has the value zero.
12 SPI2	SPI2 Clock Gate Control This bit controls the clock gate to the SPI2 module. 0 Clock disabled 1 Clock enabled
11–5 Reserved	This read-only field is reserved and always has the value zero.
4 FLEXCAN1	FlexCAN1 Clock Gate Control This bit controls the clock gate to the FlexCAN1 module. 0 Clock disabled 1 Clock enabled
3–1 Reserved	This read-only field is reserved and always has the value zero.
0 Reserved	This read-only field is reserved and always has the value zero.

12.2.11 System Clock Gating Control Register 4 (SIM_SCGC4)

Address: SIM_SCGC4 is 4004_7000h base + 1034h offset = 4004_8034h

Bit	31	30	29	28	27	26	25	24	23	22	21	20	19	18	17	16
R	0	1		LLWU	0					VREF	CMP	USBOTG		0		
W																
Reset	0	1	1	0	0	0	0	0	0	0	0	1	0	0	0	0
Bit	15	14	13	12	11	10	9	8	7	6	5	4	3	2	1	0
R	0		UART3	UART2	UART1	UART0	0		I2C1	I2C0	1		0	CMT	EWM	0
W																
Reset	0	0	0	0	0	0	0	0	0	0	1	1	0	0	0	0

SIM_SCGC4 field descriptions

Field	Description
31 Reserved	This read-only field is reserved and always has the value zero.
30–29 Reserved	This read-only field is reserved and always has the value one.
28 LLWU	LLWU Clock Gate Control This bit controls the clock gate to the LLWU module. 0 Clock disabled 1 Clock enabled
27–21 Reserved	This read-only field is reserved and always has the value zero.
20 VREF	VREF Clock Gate Control This bit controls the clock gate to the VREF module. 0 Clock disabled 1 Clock enabled
19 CMP	Comparator Clock Gate Control This bit controls the clock gate to the comparator module. 0 Clock disabled 1 Clock enabled
18 USBOTG	USB Clock Gate Control This bit controls the clock gate to the USB module. 0 Clock disabled 1 Clock enabled
17–14 Reserved	This read-only field is reserved and always has the value zero.
13 UART3	UART3 Clock Gate Control This bit controls the clock gate to the UART3 module. 0 Clock disabled 1 Clock enabled
12 UART2	UART2 Clock Gate Control This bit controls the clock gate to the UART2 module. 0 Clock disabled 1 Clock enabled
11 UART1	UART1 Clock Gate Control This bit controls the clock gate to the UART1 module.

Table continues on the next page...

SIM_SCGC4 field descriptions (continued)

Field	Description
	0 Clock disabled 1 Clock enabled
10 UART0	UART0 Clock Gate Control This bit controls the clock gate to the UART0 module. 0 Clock disabled 1 Clock enabled
9–8 Reserved	This read-only field is reserved and always has the value zero.
7 I2C1	I2C1 Clock Gate Control This bit controls the clock gate to the I ² C1 module. 0 Clock disabled 1 Clock enabled
6 I2C0	I2C0 Clock Gate Control This bit controls the clock gate to the I ² C0 module. 0 Clock disabled 1 Clock enabled
5–4 Reserved	This read-only field is reserved and always has the value one.
3 Reserved	This read-only field is reserved and always has the value zero.
2 CMT	CMT Clock Gate Control This bit controls the clock gate to the CMT module. 0 Clock disabled 1 Clock enabled
1 EWM	EWM Clock Gate Control This bit controls the clock gate to the EWM module. 0 Clock disabled 1 Clock enabled
0 Reserved	This read-only field is reserved and always has the value zero.

12.2.12 System Clock Gating Control Register 5 (SIM_SCGC5)

Address: SIM_SCGC5 is 4004_7000h base + 1038h offset = 4004_8038h

Bit	31	30	29	28	27	26	25	24	23	22	21	20	19	18	17	16
R	0													1	0	
W	[Shaded]															
Reset	0	0	0	0	0	0	0	0	0	0	0	0	0	1	0	0
Bit	15	14	13	12	11	10	9	8	7	6	5	4	3	2	1	0
R	0	PORTE	PORTD	PORTC	PORTB	PORTA	1		0	TSI	0			REGFILE	LPTIMER	
W	[Shaded]	[Shaded]	[Shaded]	[Shaded]	[Shaded]	[Shaded]	[Shaded]	[Shaded]	[Shaded]	[Shaded]	[Shaded]	[Shaded]	[Shaded]	[Shaded]	[Shaded]	
Reset	0	0	0	0	0	0	0	1	1	0	0	0	0	0	0	0

SIM_SCGC5 field descriptions

Field	Description
31–19 Reserved	This read-only field is reserved and always has the value zero.
18 Reserved	This read-only field is reserved and always has the value one.
17–14 Reserved	This read-only field is reserved and always has the value zero.
13 PORTE	Port E Clock Gate Control This bit controls the clock gate to the Port E module. 0 Clock disabled 1 Clock enabled
12 PORTD	Port D Clock Gate Control This bit controls the clock gate to the Port D module. 0 Clock disabled 1 Clock enabled
11 PORTC	Port C Clock Gate Control This bit controls the clock gate to the Port C module. 0 Clock disabled 1 Clock enabled
10 PORTB	Port B Clock Gate Control This bit controls the clock gate to the Port B module.

Table continues on the next page...

SIM_SCGC5 field descriptions (continued)

Field	Description
	0 Clock disabled 1 Clock enabled
9 PORTA	Port A Clock Gate Control This bit controls the clock gate to the Port A module. 0 Clock disabled 1 Clock enabled
8–7 Reserved	This read-only field is reserved and always has the value one.
6 Reserved	This read-only field is reserved and always has the value zero.
5 TSI	TSI Clock Gate Control This bit controls the clock gate to the TSI module. 0 Clock disabled 1 Clock enabled
4–2 Reserved	This read-only field is reserved and always has the value zero.
1 REGFILE	Register File Clock Gate Control This bit controls the clock gate to the Register File module. 0 Clock disabled 1 Clock enabled
0 LPTIMER	Low Power Timer Clock Gate Control This bit controls the clock gate to the Low Power Timer module. 0 Clock disabled 1 Clock enabled

12.2.13 System Clock Gating Control Register 6 (SIM_SCGC6)

Address: SIM_SCGC6 is 4004_7000h base + 103Ch offset = 4004_803Ch

Bit	31	30	29	28	27	26	25	24	23	22	21	20	19	18	17	16
R	0	1		0		0						0			0	
W			RTC		ADC0		FTM1	FTM0	PIT	PDB	USBDCD			CRC		
Reset	0	1	0	0	0	0	0	0	0	0	0	0	0	0	0	0
Bit	15	14	13	12	11	10	9	8	7	6	5	4	3	2	1	0
R		0						0					0			
W	I2S		SPI1	SPI0								FLEXCAN0			DMAMUX	FTFL
Reset	0	0	0	0	0	0	0	0	0	0	0	0	0	0	0	1

SIM_SCGC6 field descriptions

Field	Description
31 Reserved	This read-only field is reserved and always has the value zero.
30 Reserved	This read-only field is reserved and always has the value one.
29 RTC	RTC Clock Gate Control This bit controls the clock gate to the RTC module. 0 Clock disabled 1 Clock enabled
28 Reserved	This read-only field is reserved and always has the value zero.
27 ADC0	ADC0 Clock Gate Control This bit controls the clock gate to the ADC0 module. 0 Clock disabled 1 Clock enabled
26 Reserved	This read-only field is reserved and always has the value zero.
25 FTM1	FTM1 Clock Gate Control This bit controls the clock gate to the FTM1 module. 0 Clock disabled 1 Clock enabled

Table continues on the next page...

SIM_SCGC6 field descriptions (continued)

Field	Description
24 FTM0	FTM0 Clock Gate Control This bit controls the clock gate to the FTM0 module. 0 Clock disabled 1 Clock enabled
23 PIT	PIT Clock Gate Control This bit controls the clock gate to the PIT module. 0 Clock disabled 1 Clock enabled
22 PDB	PDB Clock Gate Control This bit controls the clock gate to the PDB module. 0 Clock disabled 1 Clock enabled
21 USBDCD	USB DCD Clock Gate Control This bit controls the clock gate to the USB DCD module. 0 Clock disabled 1 Clock enabled
20–19 Reserved	This read-only field is reserved and always has the value zero.
18 CRC	CRC Clock Gate Control This bit controls the clock gate to the CRC module. 0 Clock disabled 1 Clock enabled
17–16 Reserved	This read-only field is reserved and always has the value zero.
15 I2S	I2S Clock Gate Control This bit controls the clock gate to the I ² S module. 0 Clock disabled 1 Clock enabled
14 Reserved	This read-only field is reserved and always has the value zero.
13 SPI1	SPI1 Clock Gate Control This bit controls the clock gate to the SPI1 module. 0 Clock disabled 1 Clock enabled

Table continues on the next page...

SIM_SCGC6 field descriptions (continued)

Field	Description
12 SPI0	<p>SPI0 Clock Gate Control</p> <p>This bit controls the clock gate to the SPI0 module.</p> <p>0 Clock disabled 1 Clock enabled</p>
11–5 Reserved	This read-only field is reserved and always has the value zero.
4 FLEXCAN0	<p>FlexCAN0 Clock Gate Control</p> <p>This bit controls the clock gate to the FlexCAN0 module.</p> <p>0 Clock disabled 1 Clock enabled</p>
3–2 Reserved	This read-only field is reserved and always has the value zero.
1 DMAMUX	<p>DMA Mux Clock Gate Control</p> <p>This bit controls the clock gate to the DMA Mux module.</p> <p>0 Clock disabled 1 Clock enabled</p>
0 FTFL	<p>Flash Memory Clock Gate Control</p> <p>This bit controls the clock gate to the flash memory.</p> <p>0 Clock disabled 1 Clock enabled</p>

12.2.14 System Clock Gating Control Register 7 (SIM_SCGC7)

Address: SIM_SCGC7 is 4004_7000h base + 1040h offset = 4004_8040h

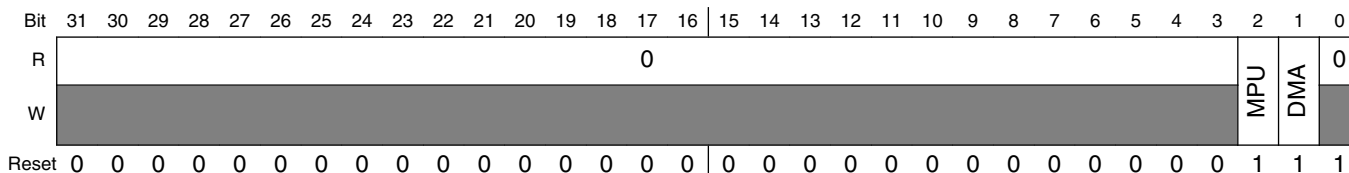

SIM_SCGC7 field descriptions

Field	Description
31–3 Reserved	This read-only field is reserved and always has the value zero.
2 MPU	MPU Clock Gate Control

Table continues on the next page...

SIM_SCGC7 field descriptions (continued)

Field	Description
	This bit controls the clock gate to the MPU module. 0 Clock disabled 1 Clock enabled
1 DMA	DMA Clock Gate Control This bit controls the clock gate to the DMA module. 0 Clock disabled 1 Clock enabled
0 Reserved	This read-only field is reserved and always has the value zero.

12.2.15 System Clock Divider Register 1 (SIM_CLKDIV1)

The CLKDIV1 register cannot be written to when the device is in VLPR mode.

Address: SIM_CLKDIV1 is 4004_7000h base + 1044h offset = 4004_8044h

Bit	31	30	29	28	27	26	25	24	23	22	21	20	19	18	17	16	15	14	13	12	11	10	9	8	7	6	5	4	3	2	1	0
R									0								0															
W																																
Reset	x*	x*	x*	x*	x*	x*	x*	x*	x*	x*	x*	x*	x*	x*	x*	x*	x*	x*	x*	x*	x*	x*	x*	x*	x*	x*	x*	x*	x*	x*	x*	x*

* Notes:

- x = Undefined at reset.

SIM_CLKDIV1 field descriptions

Field	Description
31–28 OUTDIV1	Clock 1 output divider value This field sets the divide value for the core/system clock. At the end of reset, it is loaded with either 0000 or 0111 depending on FTFL_FOFT[LPBOOT]. 0000 Divide-by-1. 0001 Divide-by-2. 0010 Divide-by-3. 0011 Divide-by-4. 0100 Divide-by-5. 0101 Divide-by-6. 0110 Divide-by-7. 0111 Divide-by-8. 1000 Divide-by-9. 1001 Divide-by-10. 1010 Divide-by-11. 1011 Divide-by-12.

Table continues on the next page...

SIM_CLKDIV1 field descriptions (continued)

Field	Description
	1100 Divide-by-13. 1101 Divide-by-14. 1110 Divide-by-15. 1111 Divide-by-16.
27–24 OUTDIV2	Clock 2 output divider value This field sets the divide value for the peripheral clock. At the end of reset, it is loaded with either 0000 or 0111 depending on FTFL_FOPT[LPBOOT]. 0000 Divide-by-1. 0001 Divide-by-2. 0010 Divide-by-3. 0011 Divide-by-4. 0100 Divide-by-5. 0101 Divide-by-6. 0110 Divide-by-7. 0111 Divide-by-8. 1000 Divide-by-9. 1001 Divide-by-10. 1010 Divide-by-11. 1011 Divide-by-12. 1100 Divide-by-13. 1101 Divide-by-14. 1110 Divide-by-15. 1111 Divide-by-16.
23–20 Reserved	This read-only field is reserved and always has the value zero.
19–16 OUTDIV4	Clock 4 output divider value This field sets the divide value for the flash clock. At the end of reset, it is loaded with either 0001 or 1111 depending on FTFL_FOPT[LPBOOT]. 0000 Divide-by-1. 0001 Divide-by-2. 0010 Divide-by-3. 0011 Divide-by-4. 0100 Divide-by-5. 0101 Divide-by-6. 0110 Divide-by-7. 0111 Divide-by-8. 1000 Divide-by-9. 1001 Divide-by-10. 1010 Divide-by-11. 1011 Divide-by-12. 1100 Divide-by-13. 1101 Divide-by-14. 1110 Divide-by-15. 1111 Divide-by-16.

Table continues on the next page...

SIM_CLKDIV1 field descriptions (continued)

Field	Description
15–0 Reserved	This read-only field is reserved and always has the value zero.

12.2.16 System Clock Divider Register 2 (SIM_CLKDIV2)

Address: SIM_CLKDIV2 is 4004_7000h base + 1048h offset = 4004_8048h

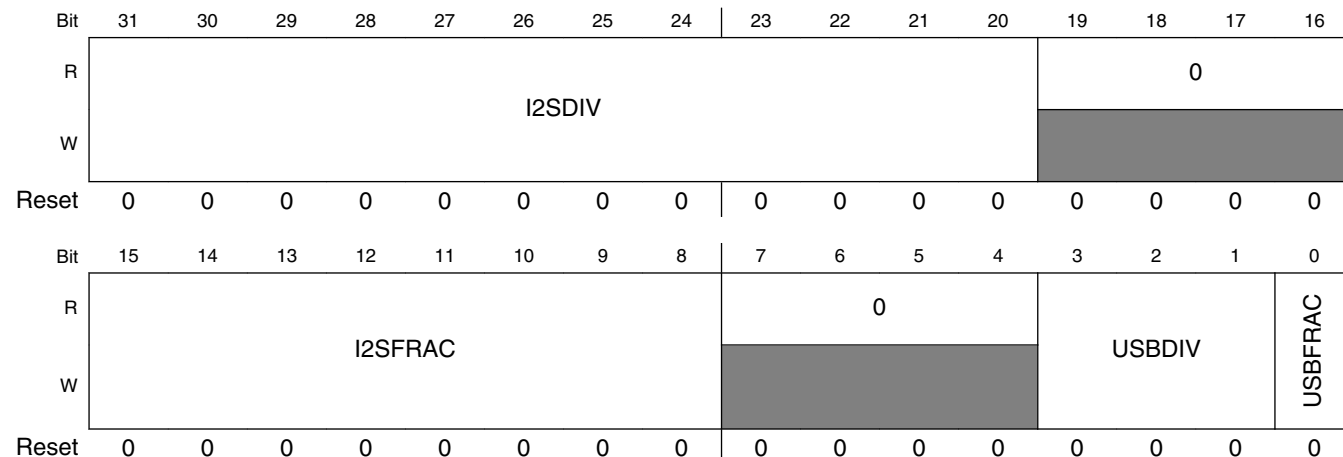

SIM_CLKDIV2 field descriptions

Field	Description
31–20 I2SDIV	I2S clock divider value This field sets the divide value for when the fractional clock divider is used as the source for the I ² S master clock. The clock input to the fractional clock divider is set by the SOPT2[I2SSRC] bit. Divider output clock = Divider input clock × [(I2SFRAC+1) / (I2SDIV+1)] NOTE: The I2S clock must be disabled (SCGC6[I2S] = 0) before altering this bitfield.
19–16 Reserved	This read-only field is reserved and always has the value zero.
15–8 I2SFRAC	I2S clock divider fraction This field sets the multiply value for when the fractional clock divider is used as a the source for I ² S master clock. The clock input to the fractional clock divider is set by the SOPT2[I2SSRC] bit. Divider output clock = Divider input clock × [(I2SFRAC+1) / (I2SDIV+1)] NOTE: The I2S clock must be disabled (SCGC6[I2S] = 0) before altering this bitfield.
7–4 Reserved	This read-only field is reserved and always has the value zero.
3–1 USB DIV	USB clock divider divisor This field sets the divide value for the fractional clock divider when the MCGFLLCLK/MCGPLLCLK clock is the USB clock source (SOPT2[USBSRC] = 1).

Table continues on the next page...

SIM_CLKDIV2 field descriptions (continued)

Field	Description
	Divider output clock = Divider input clock × [(USBFRAC+1) / (USBDIV+1)]
0 USBFRAC	<p>USB clock divider fraction</p> <p>This field sets the fraction multiply value for the fractional clock divider when the MCGFLLCLK/MCGPLLCLK clock is the USB clock source (SOPT2[USBSRC] = 1).</p> <p>Divider output clock = Divider input clock × [(USBFRAC+1) / (USBDIV+1)]</p>

12.2.17 Flash Configuration Register 1 (SIM_FCFG1)

The EESIZE and DEPART fields are not applicable.

Address: SIM_FCFG1 is 4004_7000h base + 104Ch offset = 4004_804Ch

Bit	31	30	29	28	27	26	25	24	23	22	21	20	19	18	17	16	15	14	13	12	11	10	9	8	7	6	5	4	3	2	1	0
R	NVMSIZE				PFSIZE				0				EESIZE				0				DEPART				0							
W	x																															
Reset	x																															

* Notes:

- x = Undefined at reset.

SIM_FCFG1 field descriptions

Field	Description
31–28 NVMSIZE	<p>FlexNVM size</p> <p>This field specifies the amount of FlexNVM memory available on the device. Undefined values are reserved.</p> <p>0000 0 KB of FlexNVM 0111 128 KB of FlexNVM, 16 KB protection region 1001 256 KB of FlexNVM, 32 KB protection region 1111 256 KB of FlexNVM, 32 KB protection region</p>
27–24 PFSIZE	<p>Program flash size</p> <p>This field specifies the amount of program flash memory available on the device. Undefined values are reserved.</p> <p>0111 128 KB of program flash memory, 4 KB protection region 1001 256 KB of program flash memory, 8 KB protection region 1011 512 KB of program flash memory, 16 KB protection region 1111 For devices without FlexNVM (SIM_FCFG2[PFLSH]=1): 512 KB of program flash memory, 16 KB protection region</p>
23–20 Reserved	This read-only field is reserved and always has the value zero.

Table continues on the next page...

SIM_FCFG1 field descriptions (continued)

Field	Description
19–16 EESIZE	EEPROM size EEPROM data size. 0000 Reserved 0001 Reserved 0010 4 KB 0011 2 KB 0100 1 KB 0101 512 Bytes 0110 256 Bytes 0111 128 Bytes 1000 64 Bytes 1001 32 Bytes 1010-1110 Reserved 1111 0 Bytes For devices without FlexNVM: Reserved
15–12 Reserved	This read-only field is reserved and always has the value zero.
11–8 DEPART	FlexNVM partition Reserved
7–0 Reserved	This read-only field is reserved and always has the value zero.

12.2.18 Flash Configuration Register 2 (SIM_FCFG2)

Address: SIM_FCFG2 is 4004_7000h base + 1050h offset = 4004_8050h

Bit	31	30	29	28	27	26	25	24	23	22	21	20	19	18	17	16
R	SWAPPFLSH	0	MAXADDR0						PFLSH	0	MAXADDR1					
W	[Shaded]															
Reset	x*	x*	x*	x*	x*	x*	x*	x*	x*	x*	x*	x*	x*	x*	x*	x*
Bit	15	14	13	12	11	10	9	8	7	6	5	4	3	2	1	0
R	0															
W	[Shaded]															
Reset	x*	x*	x*	x*	x*	x*	x*	x*	x*	x*	x*	x*	x*	x*	x*	x*

* Notes:

- x = Undefined at reset.

SIM_FCFG2 field descriptions

Field	Description
31 SWAPPFLSH	Swap program flash Indicates that swap is active. 0 Swap is not active. 1 Swap is active.
30 Reserved	This read-only field is reserved and always has the value zero.
29–24 MAXADDR0	Max address block 0 This field concatenated with 13 zeros indicates the first invalid address of flash block 0 (program flash 0). For example, if MAXADDR0 = 0x20 the first invalid address of flash block 0 is 0x0004_0000. This would be the MAXADDR0 value for a device with 256 KB program flash in flash block 0.
23 PFLSH	Program flash

Table continues on the next page...

SIM_FCFG2 field descriptions (continued)

Field	Description
	0 Reserved 1 Physical flash block 1 is used as program flash
22 Reserved	This read-only field is reserved and always has the value zero.
21–16 MAXADDR1	Max address block 1 This field concatenated with 13 zeros plus the value of the MAXADDR1 field indicates the first invalid address of the second program flash block (flash block 1). For example, if MAXADDR0 = MAXADDR1 = 0x20 the first invalid address of flash block 1 is 0x4_0000 + 0x4_0000. This would be the MAXADDR1 value for a device with 512 KB program flash memory and no FlexNVM.
15–0 Reserved	This read-only field is reserved and always has the value zero.

12.2.19 Unique Identification Register High (SIM_UIDH)

Address: SIM_UIDH is 4004_7000h base + 1054h offset = 4004_8054h

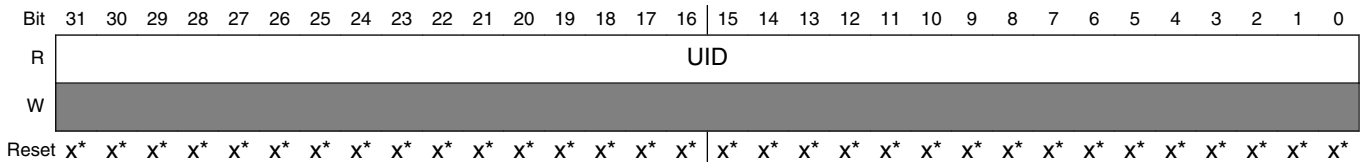

* Notes:

- x = Undefined at reset.

SIM_UIDH field descriptions

Field	Description
31–0 UID	Unique Identification Unique identification for the device.

12.2.20 Unique Identification Register Mid-High (SIM_UIDMH)

Address: SIM_UIDMH is 4004_7000h base + 1058h offset = 4004_8058h

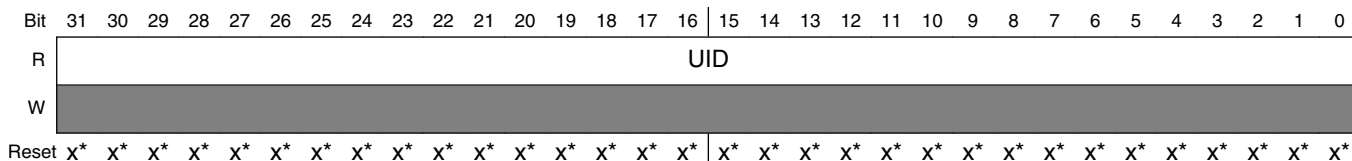

* Notes:

- x = Undefined at reset.

SIM_UIDMH field descriptions

Field	Description
31–0 UID	Unique Identification Unique identification for the device.

12.2.21 Unique Identification Register Mid Low (SIM_UIDML)

Address: SIM_UIDML is 4004_7000h base + 105Ch offset = 4004_805Ch

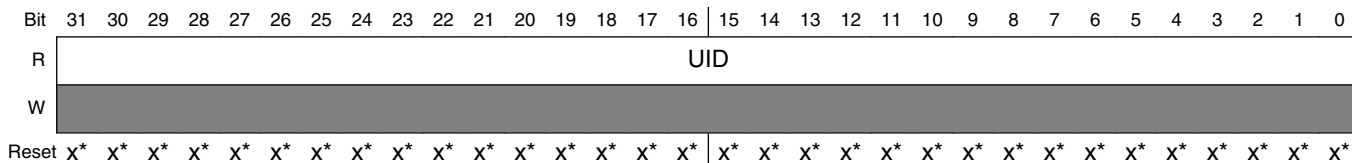

* Notes:

- x = Undefined at reset.

SIM_UIDML field descriptions

Field	Description
31–0 UID	Unique Identification Unique identification for the device.

12.2.22 Unique Identification Register Low (SIM_UIDL)

Address: SIM_UIDL is 4004_7000h base + 1060h offset = 4004_8060h

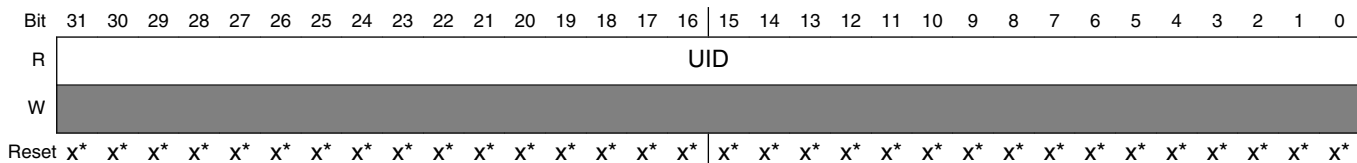

* Notes:

- x = Undefined at reset.

SIM_UIDL field descriptions

Field	Description
31–0 UID	Unique Identification Unique identification for the device.

12.3 Functional description

See [Introduction](#) section.



Chapter 13

Mode Controller

13.1 Introduction

NOTE

For the chip-specific implementation details of this module's instances see the chip configuration chapter.

This section discusses the mode controller (MC) which controls power management and reset mechanisms including the various sources of resets on the device.

The MC provides:

- control and protection on entry and exit to each power mode
- control for the [Power Management Controller \(PMC\)](#)
- reset entry and exit for the complete MCU

The device's operating power modes are described in this chapter. Entry into each mode, exit from each mode, and functionality while in each of the modes are described.

This chapter also discusses basic information about all reset sources in one place for easy reference. Modules that cause resets (such as the watchdog and the low leakage wake up (LLWU) modules) discuss the reset operation in their own chapters.

13.1.1 Features

- Power mode entry/exit and protection
- Reset control features include:
 - Multiple sources of reset for flexible system configuration and reliable operation
 - System reset status (SRSH and SRSL) registers to indicate source of most recent reset

13.1.2 Modes of Operation

The ARM CPU has three primary modes of operation: run, sleep, and deep sleep. The WFI instruction is used to invoke sleep and deep sleep modes. For Freescale microcontrollers, run, wait and stop are the common terminology used for the primary operating modes. The following table shows the translation between the ARM CPU and the MCU power modes.

ARM CPU mode	MCU mode
Sleep	Wait
Deep sleep	Stop

Accordingly, the ARM CPU documentation refers to sleep and deep sleep, while the Freescale MCU documentation normally uses wait and stop.

This device augments stop, wait, and run in a number of ways. The power management controller (PMC) contains a run and a stop mode regulator. Run regulation is used in normal run, wait and stop modes. Stop mode regulation is used during all very low power and low leakage modes. During stop mode regulation the bus frequencies are limited for the very low power modes.

The PMC provides the user with multiple power options. The low power operating modes can drastically reduce run time power when maximum bus frequency is not required to handle the application needs. From normal run mode, the run mode (RUNM) bit field can be modified to change the the MCU into the very lower power run (VLPR) mode when limited frequency is required during the application. For the low power run mode, a corresponding wait and stop mode can be entered.

Depending on the needs of the user application, a variety of stop modes are available that allow the state retention, partial power down or full power down of certain logic and/or memory. I/O states are held in all modes of operation. Several registers are used to configure the various modes of operation for the device.

The following table describes the power modes available for the device.

Table 13-1. Power modes

Mode	Description
Run	MCU can be run at full speed and the internal supply is fully regulated (run regulation mode). This mode is also referred to as normal run mode.
Wait	In ARM architectures, the Core Clock to the ARM Cortex-M4 core is shut off. The System Clock continues to operate; Bus Clocks if enabled continue to operate; run regulation is maintained.
Stop	In ARM architectures, Core Clock and System Clock to the ARM Cortex-M4 core shut off immediately. System Clock to other masters and Bus Clocks are stopped after all stop acknowledge signals from supporting peripherals are valid.

Table continues on the next page...

Table 13-1. Power modes (continued)

Mode	Description
VLPR	The Core Clock, System Clock and Bus Clocks maximum frequency is restricted to 2MHz max, Flash Clock is restricted to 1MHz. The slow IRC within the MCG must not be enabled when VLPR is entered.
VLPW	In ARM architectures, the Core Clock to the ARM Cortex-M4 core is shut off. The System Clock continues to operate; Bus Clocks if enabled continue to operate; System and Bus clock restricted to 2MHz max, Flash Clock is restricted to 1MHz
VLPS	In ARM architectures, Core Clock and System Clock to the ARM Cortex-M4 core shut off immediately. System clock to other masters and Bus Clocks are stopped after all stop acknowledge signals from supporting peripherals are valid.
LLS	In ARM architectures, Core Clock and System Clock to the ARM Cortex-M4 core shut off immediately. System clock and Bus Clocks are stopped after all stop acknowledge signals from supporting peripherals are valid. MCU is placed in a low leakage mode by reducing the voltage to internal logic. Internal logic states are retained.
VLLS3	In ARM architectures, Core Clock and System Clock to the ARM Cortex-M4 core shut off immediately. System clock to other masters and Bus Clocks are stopped after all stop acknowledge signals from supporting peripherals are valid. MCU is placed in a low leakage mode by powering down the internal logic. System RAM contents retained and I/O states held. Internal logic states are not retained.
VLLS2	In ARM architectures, Core Clock and System Clock to the ARM Cortex-M4 core shut off immediately. System clock to other masters and Bus Clocks are stopped after all stop acknowledge signals from supporting peripherals are valid. MCU is placed in a low leakage mode by powering down the internal logic and part of system RAM. The rest of the system RAM contents are retained and I/O states held. Internal logic states are not retained. NOTE: See the device's Chip Configuration details for the amount of SRAM retained in VLLS2 mode.
VLLS1	In ARM architectures, Core Clock and System Clock to the ARM Cortex-M4 core shut off immediately. System clock to other masters and Bus Clocks are stopped after all stop acknowledge signals from supporting peripherals are valid. MCU is placed in a low leakage mode by powering down the internal logic and all system RAM. A 32-byte register file (available in all modes) contents retained and I/O states held. Internal logic states are not retained.

13.1.2.1 Power Mode Transitions

The following shows the power mode state transitions available on the device.

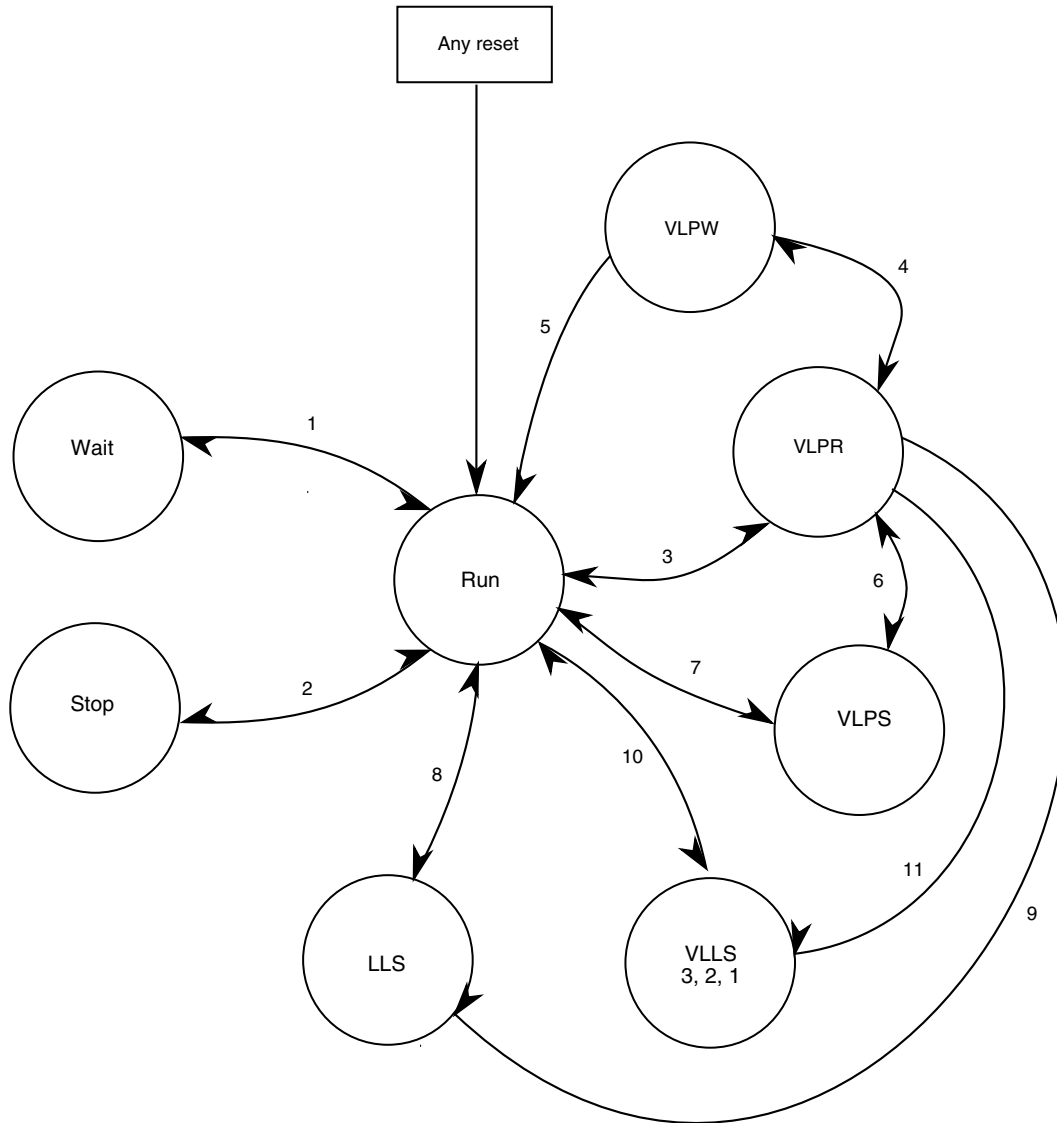

Figure 13-1. Power Mode State Diagram

The following table defines triggers for the various state transitions shown in the previous figure.

Table 13-2. Power mode transition triggers

Transition #	From	To	Trigger Conditions
1	Run	Wait	Sleep-now or sleep-on-exit modes entered with SLEEPDEEP clear, controlled in System Control Register in ARM core.
	Wait	Run	Interrupt or Reset
2	Run	STOP	Sleep-now or sleep-on-exit modes entered with SLEEPDEEP set, controlled in System Control Register in ARM core
	STOP	Run	Interrupt or Reset

Table continues on the next page...

Table 13-2. Power mode transition triggers (continued)

Transition #	From	To	Trigger Conditions
3	Run	VLPR	Reduce system, bus and core frequency to 2 MHz or less, Flash access limited to 1MHz. AVLP=1, Set RUNM = 10. NOTE: Poll VLPRS bit before transitioning out of VLPR mode.
	VLPR	Run	Set RUNM = 00 or Interrupt with LPWUI = 1 or Reset. NOTE: Poll REGONS bit before increasing frequency.
4	VLPR	VLPW	Sleep-now or sleep-on-exit modes entered with SLEEPDEEP clear, controlled in System Control Register in ARM core
	VLPW	VLPR	Interrupt with LPWUI = 0
5	VLPW	Run	Interrupt with LPWUI = 1 or Reset
6	VLPR	VLPS	LPLLSM=000 or 010, Sleep-now or sleep-on-exit modes entered with SLEEPDEEP set, controlled in System Control Register in ARM core
	VLPS	VLPR	Interrupt with LPWUI = 0
7	Run	VLPS	AVLP=1, LPLLSM=010, Sleep-now or sleep-on-exit modes entered with SLEEPDEEP set, controlled in System Control Register in ARM core NOTE: Hardware will set LPWUI and will remain set until software clears.
	VLPS	Run	Interrupt with LPWUI = 1 or Reset
8	Run	LLS	LPLLSM=011, Sleep-now or sleep-on-exit modes entered with SLEEPDEEP set, controlled in System Control Register in ARM core
	LLS	Run	Wakeup from enabled LLWU input source or RESET pin
9	VLPR	LLS	LPLLSM=011, Sleep-now or sleep-on-exit modes entered with SLEEPDEEP set, controlled in System Control Register in ARM core
10	Run	VLLS(3,2,1)	LPLLSM = (see PMCTRL register description for VLLS configuration), Sleep-now or sleep-on-exit modes entered with SLEEPDEEP set, controlled in System Control Register in ARM core
	VLLS(3,2,1)	Run	Wakeup from enabled LLWU input source or RESET pin

Table continues on the next page...

Table 13-2. Power mode transition triggers (continued)

Transition #	From	To	Trigger Conditions
11	VLPR	VLLS(3,2,1)	LPLLSM = (see PMCTRL register description for VLLS configuration), Sleep-now or sleep-on-exit modes entered with SLEEPDEEP set, controlled in System Control Register in ARM core

13.1.2.2 Run Modes

The device contains two different run modes:

- Run
- Very low power run (VLPR)

13.1.2.2.1 Run Mode

This is the normal operating mode for the device.

This mode is selected after any reset. When the ARM processor exits reset, it sets up the stack, program counter (PC), and link register (LR):

- The processor reads the start SP (SP_main) from vector-table offset 0x000
- The processor reads the start PC from vector-table offset 0x004
- LR is set to 0xFFFF_FFFF.

To reduce power in this mode, disable unused modules by clearing the peripherals corresponding clock gating control bit in the SIM's registers.

13.1.2.2.2 Very Low Power Run (VLPR) Mode

In VLPR, the on-chip voltage regulator is put into a stop mode regulation state. In this state, the regulator is designed to supply enough current to the MCU over a reduced frequency. To further reduce power in this mode, disable the clocks to unused modules in the peripherals' corresponding clock gating control bits in the SIM's registers.

Before entering this mode, the following conditions must be met:

- One of two clock sources selected:
 - Either BLPE is the selected clock mode for the MCG or
 - BLPI with the 2MHz IRC.
- The system, bus, and core frequency is 2 MHz or less.
- Flash frequency is 1 MHz or less.
- Mode protection must be set to allow VLP modes (AVLP = 1).

- RUNM set to 10b to enter VLPR.
- Flash programming/erasing is not allowed.
- The slow IRC must not be enabled.
- All clock monitors must be disabled before entering VLPR.

While in VLPR, the regulator is slow responding and cannot handle fast load transitions. Therefore, do not change the clock frequency. This includes a requirement to not modify the module clock enables in the SIM or any clock divider registers.

To re-enter normal run mode, simply clear RUNM. The REGONS and VLPRS bits in the REGSC register are read-only status bits that indicate if the regulator is in run regulation mode or not:

- When REGONS is set, the regulator is in run regulation mode and the MCU can run at full speed in any clock mode. If a higher execution frequency is desired, poll REGONS until it is set when returning from VLPR.
- When VLPRS is set, the system is fully in VLPR mode.

NOTE

- Do not enter VLPS, LLS, or VLLSx until the transition to VLPR completes as indicated by the VLPRS bit.
- Do not attempt to transition out of run mode until the REGONS bit sets.

VLPR also provides the option to return to run regulation if any interrupt occurs. This is done by setting the low power wake up on interrupt (LPWUI) bit in the PMCTRL register. In the interrupt service routine (ISR) it is not necessary to poll the REGONS before increasing the frequency. The VLPR frequency limits are such that the regulator is in run regulation and REGONS is set before the ISR is entered.

Any reset exits VLPR, clears RUNM, REGONS is set, and the device is in normal run mode after the CPU exits its reset flow.

13.1.2.3 Wait Modes

This device contains two different wait modes:

- Wait
- Very low power wait

13.1.2.3.1 Wait Mode

Wait mode is entered when the ARM core enters the sleep-now or sleep-on-exit modes. The ARM CPU enters a low-power state in which it is not clocked, but peripherals continue to be clocked provided they are enabled and clock gating to the peripheral is enabled via the SIM.

When an interrupt request occurs, the CPU exits wait mode and resumes processing, beginning with the stacking operations leading to the interrupt service routine.

An asserted $\overline{\text{RESET}}$ pin or LVD (if the LVD system is enabled) exits wait mode, returning the device to normal run mode.

13.1.2.3.2 Very Low Power Wait (VLPW) Mode

VLPW is entered by the entering the "sleep-now" or "sleep-on-exit" mode while the MCU is in the very low power run (VLPR) mode and configured appropriately.

In VLPW, the on-chip voltage regulator remains in its stop regulation state. In this state, the regulator is designed to supply enough current to the MCU over a reduced frequency. To further reduce power in this mode, disable the clocks to unused modules by clearing the peripherals' corresponding clock gating control bits in the SIM.

VLPR mode restrictions also apply to VLPW.

VLPW mode provides the option to return to full-regulated normal run mode if any enabled interrupt occurs. This is done by setting the low power wake up on interrupt (LPWUI) bit in the PMCTRL register. Wait for REGONS status to set before increasing the frequency.

If the LPWUI bit is clear when the interrupt from VLPW occurs, the device returns to VLPR mode to execute the interrupt service routine. Wait for VLPRS status to set before transitioning to other power modes.

An asserted $\overline{\text{RESET}}$ pin or a watchdog timeout exits VLPW and clears the RUNM and WAITE bits. This returns the regulator to run regulation and the device to normal run mode.

13.1.2.4 Stop Modes

This device contains a variety of stop modes to meet your application needs. The stop modes range from: stopped CPU where all states are saved and certain asynchronous mode peripherals are operating to only I/Os are held, a small register file is retained, and

certain asynchronous mode peripherals are operating with the remainder of the MCU powered off. The tradeoffs depend upon the user's application, where power usage and state retention versus functional needs are weighed.

The various stop modes are selected by setting the appropriate bits in the power mode protection (PMPROT) and power mode control (PMCTRL) registers. The selected stop mode is entered during the sleep-now or sleep-on-exit entry with the SLEEPDEEP bit set in the System Control Register in the ARM core.

The available stop modes are:

- Stop
- Very low power stop (VLPS)
- Low leakage stop (LLS)
- Very low leakage stop 1 (VLLS1)
- Very low leakage stop 2 (VLLS2)
- Very low leakage stop 3 (VLLS3)

13.1.2.4.1 Stop Mode

Stop mode is entered via the sleep-now or sleep-on-exit with the SLEEPDEEP bit set in the System Control Register in the ARM core.

The MCG module can be configured to leave the reference clocks running.

A module capable of providing an asynchronous interrupt to the device (for example, an enabled pin interrupt, NMI, RTC, LVW, UART wakeup on edge, CMP, or ADC) takes the device out of stop mode and returns the device to normal run mode. Reference [Table 13-1](#) for peripheral, I/O, and memory operation in stop. When an interrupt request occurs, the CPU exits stop mode and resumes processing, beginning with the stacking operations leading to the interrupt service routine.

An asserted $\overline{\text{RESET}}$ pin, a watchdog timeout, or LVD with LVDRE set exits stop mode. The device returns to normal run mode via a MCU reset.

13.1.2.4.2 Very Low Power Stop (VLPS) Mode

VLPS mode can be entered in one of two ways:

- Entry into stop via the sleep-now or sleep-on-exit with the SLEEPDEEP bit set in the System Control Register in the ARM core while the MCU is in very low power run (VLPR) mode and configured as per [Table 13-2](#).
- When the MCU is in normal run mode with LPLLSM set to 010b, entry into stop via the sleep-now or sleep-on-exit with the SLEEPDEEP bit set in the System Control

Register in the ARM core forces the MCU into VLPS and hardware sets the LPWUI bit set.

In VLPS, the on-chip voltage regulator remains in its stop regulation state as in VLPR. On transitions from VLPR to VLPS with LPLLSM set to 000b, hardware forces LPLLSM to value of 010b.

A module capable of providing an asynchronous interrupt to the device (for example, an enabled pin interrupt, NMI, RTC, UART wakeup on edge, CMP or ADC) takes the device out of VLPS and returns the device to VLPR provided the LPWUI bit is clear.

If LPWUI is set, the device returns to normal run mode upon an interrupt request. The REGONS bit must be set before allowing the system to return to a frequency higher than allowed in VLPR.

An asserted $\overline{\text{RESET}}$ pin or a watchdog timeout causes VLPS exit. This returns the device to normal run mode.

13.1.2.4.3 Low-Leakage Stop (LLS) Mode

Low leakage stop (LLS) mode can be entered from normal run or VLPR modes.

The MCU enters LLS mode if:

- In sleep-now or sleep-on-exit mode, the SLEEPDEEP bit is set in the System Control Register in the ARM core, and
- The device is configured as per [Table 13-2](#).

In LLS, the on-chip voltage regulator is in stop regulation. Most of the peripherals are put in a state-retention mode that does not allow them to operate while in LLS.

In LLS, configure the low leakage wake up (LLWU) module to enable the desired wakeup sources. The available wakeup sources in LLS are detailed in the Chip Configuration details for this device.

After wakeup from LLS, the device returns to normal run mode with a pending LLWU module interrupt. In the LLWU interrupt service routine (ISR) poll the LLWU module wakeup flags to determine the source of the wakeup.

NOTE

The LLWU interrupt must not be masked by the interrupt controller to avoid a scenario where the system does not fully exit stop mode on an LLS recovery.

An asserted $\overline{\text{RESET}}$ pin exits LLS. This returns the device to normal run mode. When LLS is exiting via the $\overline{\text{RESET}}$ pin, the PIN and WAKEUP bits are set in the SRSL register.

13.1.2.4.4 Very Low-Leakage Stop (VLLS3,2,1) Modes

This device contains three very low leakage modes: VLLS3, VLLS2, and VLLS1. When a reference applies to all three low leakage modes, VLLS is used.

All three of the VLLS modes can be entered from normal run or VLPR.

The MCU enters the configured VLLS mode if:

- In sleep-now or sleep-on-exit mode, the SLEEPDEEP bit is set in the System Control Register in the ARM core, and
- The device is configured as per [Table 13-2](#).

In VLLS, the on-chip voltage regulator is in its stop-regulation state.

In VLLS, configure the LLWU module to enable the desired wakeup sources. The available wakeup sources in VLLS are detailed LLWU's Chip Configuration details for this device.

When entering VLLS, each I/O pin is latched as configured before executing VLLS. Since all digital logic in the MCU is powered off, all port and peripheral data is lost during VLLS. This information must be restored before ACKISO in the LLWU is set.

An asserted $\overline{\text{RESET}}$ pin exits any VLLS mode. This returns the device to normal run mode. When exiting VLLS via the $\overline{\text{RESET}}$ pin, the PIN and WAKEUP bits are set in the SRSR register.

13.1.2.5 ARM Debug in Low Power Modes

When the MCU is secure the device disables/limits debugger operation. When the MCU is unsecure, the ARM debugger can assert two power-up request signals:

- System power up (SYSPWR bit in the Debug Port Control/Stat register)
- Debug power up (CDBGPWRUPREQ bit in the Debug Port Control/Stat register)

When asserted while in run, wait, VLPR, or VLPW, the Mode Controller drives a corresponding acknowledge for each signal (CDBGPWRUPACK, CSYSPWRUPACK). When both requests are asserted, the Mode Controller handles attempts to enter stop and VLPS by entering an emulated stop state. In this emulated stop state:

- The regulator is in stop regulation,
- The MCG-generated clock source is enabled,
- All system clocks, except core clock, are disabled,
- The debug module has access to core registers, and
- Access to the on-chip peripherals is blocked.

No debug is available while the MCU is in LLS or VLLS modes. LLS is a state-retention mode and all debug operation can continue after waking from LLS, even in cases where system wakeup is due to a system reset event.

Entering into a VLLS mode causes all the debug controls and settings to be powered off. To give time to the debugger to sync with the MCU, the MDM AP Control Register includes a Very Low Leakage Debug Request (VLLDBGREQ) bit that is set to configure the Mode Controller logic to hold the system in reset after the next recovery from a VLLS mode. This bit allows the debugger time to re-initialize the debug module before the debug session continues.

The VLLDBGREQ bit clears automatically due to the reset generated as part of the VLLS recovery.

The MDM AP Control Register also includes a Very Low Leakage Debug Acknowledge (VLLDBGACK) bit that is set to release the ARM core being held in reset following a VLLS recovery. The debugger re-initializes all debug IP and then asserts the VLLDBGACK control bit to allow the Mode Controller to release the ARM core from reset and allow CPU operation to begin.

The VLLDBGACK bit is cleared by the debugger (or can be left set as is) or clears automatically due to the reset generated as part of the next VLLS recovery.

13.1.3 MCU Reset

Resetting the MCU provides a way to start processing from a known set of initial conditions.

When the ARM processor exits reset, it sets up the stack, program counter (PC), and link register (LR).

- The processor reads the start SP (SP_main) from vector-table offset 0x000
- The processor reads the start PC from vector-table offset 0x004
- LR is set to 0xFFFF_FFFF

The device resets can be generalized into three distinct groups: POR, system resets, and debug resets.

POR reset:

- Power-on reset (POR)

System resets:

- External pin reset (PIN)

- Computer operating properly (COP) timer
- Clock generator (MCG) loss of clock reset (LOC)
- Low-voltage detect (LVD)
- Wakeup from very low leakage stop modes, VLLSx
- Software reset (SW) - by setting SYSRESETREQ bit of the NVIC's Application Interrupt and Reset Control Register
- LOCKUP - core in lockup state
- EzPort
- MDM AP Reset - by setting System Reset Request bit of the MDM AP Control Register

Debug reset:

- Asserting JTAG_TRST pin

Each of the system reset sources, with the exception of the EzPort and MDM AP reset, has an associated bit in the system reset status low (SRSL) register.

13.1.3.1 Power-On Reset (POR)

When power is initially applied to the device, or when the supply voltage drops below the power-on-reset re-arm voltage level (V_{POR}), the POR circuit causes a reset condition. As the supply voltage rises, the LVD circuit holds the MCU in reset until the supply rises above the LVD low threshold (V_{LVDL}). The POR and LVD bits in SRSL are set following a POR.

13.1.3.2 External $\overline{\text{RESET}}$ Pin

$\overline{\text{RESET}}$ is a dedicated pin. This pin is open drain and has an internal pullup device. Asserting $\overline{\text{RESET}}$ resets the device from any run, wait, stop, VLP, LLS, or VLLS mode. When the $\overline{\text{RESET}}$ pin is the cause of reset, the SRSL[PIN] bit is set.

13.1.3.3 Computer Operating Properly (COP) Timer Reset

The watchdog timer monitors the operation of the system by expecting periodic communication from the software. Generally, this is known as servicing, or refreshing, the watchdog. If this periodic refreshing does not occur, the watchdog issues a system reset. When the watchdog timer expiration causes a reset, the SRSL[COP] bit is set.

13.1.3.4 Multi-Clock Generator (MCG) Loss-of-Clock (LOC) Reset

The MCG module supports an external reference clock. If the clock monitor is enabled (MCG_C6[CME] is set) and the external reference falls below a certain frequency (specified in the MCG_C2[RANGE] field), the MCU resets. If a loss of clock causes a reset, the SRSL[LOC] bit is set.

For more details on the clock generator, see [Multi-Clock Generator \(MCG\)](#).

13.1.3.5 Low-Voltage Detect (LVD) Reset

If LVDRE is set, the LVD generates a reset upon detection of a low voltage condition. After an LVD reset has occurred, the LVD system holds the MCU in reset until the supply voltage rises above the LVD threshold (specified by the LVDV bits). The SRSL[LVD] bit is set following an LVD reset or POR.

13.1.3.6 Low Leakage Mode Recovery

The LLWU provides the means for up to 16 external pins, the $\overline{\text{RESET}}$ pin, and seven internal peripherals to wake the device from LLS and VLLS power modes. When in VLLS mode, all enabled inputs to the LLWU will generate a system reset flow when detected. When in LLS mode, only a detected $\overline{\text{RESET}}$ pin results in a recovery via a reset flow.

For LLS mode exits via $\overline{\text{RESET}}$ pin and any VLLS mode via a wakeup or reset event, the MC_SRS[WAKEUP] is set indicating a low-leakage mode was active prior to the last system reset flow. Using the $\overline{\text{RESET}}$ pin to trigger an exit from LLS or VLLS results in the MC_SRS[PIN] being set as well.

After the system reset, the LLWU continues to retain the flags indicating the source of wakeup until the user clears them or the next LLS or VLLS entry occurs.

NOTE

External pin flags are cleared by software via the LLWU registers and internal peripheral module flags are required to be cleared in associated peripheral's registers. Refer to the individual peripheral chapters for more information.

13.1.3.7 Software (SW) Reset

Setting the SYSRESETREQ bit in the NVIC's Application Interrupt and Reset Control Register forces a software reset on the device. A software reset resets of all major components except for debug.

When the device is reset by a software reset, the SRSH[SW] bit is set.

13.1.3.8 Lock-Up Reset

When the processor's built-in system state protection hardware detects the core is locked up because of an unrecoverable exception, a lock-up reset occurs.

When a lock-up condition causes a reset, the SRSH[LOCKUP] bit is set.

13.1.3.9 EzPort Reset

The EzPort generates a system reset request following execution of a RESET command via the EzPort interface. This method of reset allows the chip to boot from flash memory after it has been programmed by an external source.

13.1.3.10 MDM-AP System Reset Request

A system reset is initiated by setting the System Reset Request bit in the MDM-AP Control register. This is the primary method for resets via the debug interface. System reset is held until this bit is cleared.

13.1.3.11 JTAG Reset

The JTAG module generates a system reset when certain IR codes are selected. This functional reset is asserted when the EZPORT, EXTEST, HIGHZ and CLAMP instructions are active. The reset source from the JTAG module is released when any other IR code is selected. A JTAG reset causes the SRSH[JTAG] bit to set.

13.2 Mode Control Memory Map/Register Definition

The following table shows the registers related to the Mode Controller.

MC memory map

Absolute address (hex)	Register name	Width (in bits)	Access	Reset value	Section/page
4007_E000	System Reset Status Register High (MC_SRSH)	8	R/W	00h	13.2.1/304
4007_E001	System Reset Status Register Low (MC_SRSL)	8	R/W	82h	13.2.2/305
4007_E002	Power Mode Protection Register (MC_PMPROT)	8	R/W	00h	13.2.3/306
4007_E003	Power Mode Control Register (MC_PMCTRL)	8	R/W	00h	13.2.4/308

13.2.1 System Reset Status Register High (MC_SRSH)

The SRSH:SRSL registers include read-only status flags to indicate the source of the most recent reset. The reset state of these bits depends on what caused the MCU to reset.

Throughout this document, SRS refers to SRSH:SRSL.

NOTE

The reset value of this register depends on the reset type:

- POR — 0x00
- LVD — 0x00
- Low-leakage wake-up (LLS exit via RESET pin or any exit from VLLS) — 0x00
- Other reset — bits 2-0 are set if their corresponding reset source caused the reset

Address: MC_SRSH is 4007_E000h base + 0h offset = 4007_E000h

Bit	7	6	5	4	3	2	1	0
Read	0					SW	LOCKUP	JTAG
Write								
Reset	0	0	0	0	0	0	0	0

MC_SRSH field descriptions

Field	Description
7-3 Reserved	This read-only field is reserved and always has the value zero.
2 SW	Software Indicates reset was caused by software setting of SYSRESETREQ bit in Application Interrupt and Reset Control Register in the ARM Core 0 Reset not caused by software setting of SYSRESETREQ bit 1 Reset caused by software setting of SYSRESETREQ bit
1 LOCKUP	Core Lock-up

Table continues on the next page...

MC_SRSH field descriptions (continued)

Field	Description
	Indicates reset was caused by the ARM core indication of a LOCKUP event. 0 Reset not caused by core LOCKUP event 1 Reset caused by core LOCKUP event
0 JTAG	JTAG generated reset Indicates reset was caused by JTAG selection of certain IR codes (EZPORT, EXTEST, HIGHZ, and CLAMP). 0 Reset not caused by JTAG 1 Reset caused by JTAG

13.2.2 System Reset Status Register Low (MC_SRSL)

The SRSH:SRSL registers includes read-only status flags to indicate the source of the most recent reset. The reset state of these bits depends on what caused the MCU to reset.

Throughout this document, SRS refers to SRSH:SRSL.

NOTE

The reset value of this register depends on the reset type:

- POR — 0x82
- LVD — 0x02
- Low-leakage wake-up due to $\overline{\text{RESET}}$ pin assertion — 0x41
- Low-leakage wake-up due to other wake-up sources — 0x01
- Other reset — bits 6-5 and 2 are set if their corresponding reset source caused the reset

Address: MC_SRSL is 4007_E000h base + 1h offset = 4007_E001h

Bit	7	6	5	4	3	2	1	0
Read	POR	PIN	COP	0		LOC	LVD	WAKEUP
Write								
Reset	1	0	0	0	0	0	1	0

MC_SRSL field descriptions

Field	Description
7 POR	Power-on reset Indicates a reset was caused by the power-on detection logic. Because the internal supply voltage was ramping up at the time, the low-voltage reset (LVD) status bit is also set to indicate that the reset occurred while the internal supply was below the LVD threshold.

Table continues on the next page...

MC_SRSL field descriptions (continued)

Field	Description
	0 Reset not caused by POR 1 Reset caused by POR
6 PIN	External reset pin Indicates reset was caused by an active-low level on the external $\overline{\text{RESET}}$ pin. 0 Reset not caused by external reset pin 1 Reset caused by external reset pin
5 COP	Computer Operating Properly (COP) Watchdog Reset was caused by the COP watchdog timer timing out. This reset source can be blocked by disabling the watchdog. For more information, see the watchdog chapter. 0 Reset not caused by COP timeout 1 Reset caused by COP timeout
4–3 Reserved	This read-only field is reserved and always has the value zero.
2 LOC	Loss-of-clock reset Indicates reset was caused by a loss of external clock. The MCG clock monitor must be enabled for a loss of clock to be detected. See the MCG chapter for information on enabling the clock monitor. 0 Reset not caused by a loss of external clock. 1 Reset caused by a loss of external clock.
1 LVD	Low-voltage detect reset If the LVDRE bit is set and the supply drops below the LVD trip voltage, an LVD reset occurs. This bit is also set by POR. 0 Reset not caused by LVD trip or POR 1 Reset caused by LVD trip or POR
0 WAKEUP	Low-leakage wakeup reset Reset was caused by an enabled LLWU module wakeup source while the device was in LLS or VLLS modes. Wakeup sources in LLS is limited to the $\overline{\text{RESET}}$ pin. In VLLS, any enabled wakeup source causes a reset. This bit is cleared by any reset except WAKEUP. 0 Reset not caused by LLWU module wakeup source 1 Reset caused by LLWU module wakeup source

13.2.3 Power Mode Protection Register (MC_PMPROT)

This write-once register allows low power or low leakage modes to be entered. The actual enabling of the low power or low leakage modes is done by configuring the power mode control register (PMCTRL).

If the MCU is configured for a disallowed power mode, the MCU remains in its current power mode. For example, if in normal run (RUNM = 00, AVLP = 0) an attempt to enter VLPR using PMCTRL[RUNM] is blocked and the RUNM bits remain 00b indicating MCU is still in normal run mode.

PMPROT is write once after any reset. This write to PMPROT clears LPLLSM, which provides protection after wakeup from low power or low leakage modes. The state of LPLLSM prior to clearing due to update of PMPROT indicates which power mode was exited and should be used by initialization software for proper power mode recovery.

NOTE

The reset value of this register depends on the reset type:

- Low-leakage wake-up (LLS exit via $\overline{\text{RESET}}$ pin or any exit from VLLS) — bits 4, 2-0 unaffected
- Other reset — 0x00

Address: MC_PMPROT is 4007_E000h base + 2h offset = 4007_E002h

Bit	7	6	5	4	3	2	1	0
Read	0		AVLP	ALLS	0	AVLLS3	AVLLS2	AVLLS1
Write	[Shaded]		AVLP	ALLS	[Shaded]	AVLLS3	AVLLS2	AVLLS1
Reset	0	0	0	0	0	0	0	0

MC_PMPROT field descriptions

Field	Description
7–6 Reserved	This read-only field is reserved and always has the value zero.
5 AVLP	Allow very low power modes Provided the appropriate control bits are set up in PMCTRL, this write-once bit allows the MCU to enter the very low power modes: VLPR, VLPW, and VLPS. 0 VLPR, VLPW, and VLPS are not allowed 1 VLPR, VLPW, and VLPS are allowed
4 ALLS	Allow low leakage stop mode This write once bit allows the MCU to enter low leakage stop mode (LLS) provided the appropriate control bits are set up in PMCTRL. 0 LLS is not allowed 1 LLS is allowed
3 Reserved	This read-only field is reserved and always has the value zero.
2 AVLLS3	Allow Very Low Leakage Stop 3 Mode This write once bit allows the MCU to enter very low leakage stop 3 mode (VLLS3) provided the appropriate control bits are set up in PMCTRL.

Table continues on the next page...

MC_PMPROT field descriptions (continued)

Field	Description
	0 VLLS3 is not allowed 1 VLLS3 is allowed
1 AVLLS2	Allow very low leakage stop 2 mode This write once bit allows the MCU to enter very low leakage stop 2 mode (VLLS2) provided the appropriate control bits are set up in PMCTRL. 0 VLLS2 is not allowed 1 VLLS2 is allowed
0 AVLLS1	Allow very low leakage stop 1 mode This write once bit allows the MCU to enter very low leakage stop 1 mode (VLLS1) provided the appropriate control bits are set up in PMCTRL. 0 VLLS1 is not allowed 1 VLLS1 is allowed

13.2.4 Power Mode Control Register (MC_PMCTRL)

The PMCTRL register is used to enter the wait, low power, or low leakage modes provided the selected power mode is allowed via appropriate setting of the protection register (PMPROT).

If the MCU is configured for a disallowed power mode or to a reserved RUNM setting, the device remains in its current power mode. For example, if in normal run (RUNM = 00, AVLPM = 0) an attempt to enter VLPR using the PMCTRL[RUNM] bits is blocked and RUNM bits remain 00 indicating the device is still in normal run mode.

Before configuring the LPLLSM bits, the corresponding allow bit in PMPROT must be set. Writes to LPLLSM that do not meet this criteria are ignored.

A successful write to PMPROT clears the LPLLSM bits. The state of PMCTRL[LPLLSM] prior to clearing due to update of PMPROT indicates which power mode was exited and should be used by initialization software for proper power mode recovery.

NOTE

The reset value of this register depends on the reset type:

- Low-leakage wake-up (LLS exit via RESET pin or any exit from VLLS) — bits 2-0 unaffected
- Other reset — 0x00

Address: MC_PMCTRL is 4007_E000h base + 3h offset = 4007_E003h



MC_PMCTRL field descriptions

Field	Description
7 LPWUI	<p>Low Power Wake Up on Interrupt</p> <p>Controls if the voltage regulator exits stop regulation when any active MCU interrupt occurs, returning the MCU to normal run mode.</p> <p>0 The voltage regulator remains in stop regulation on an interrupt 1 The voltage regulator exits stop regulation on an interrupt</p>
6–5 RUNM	<p>Run Mode Enable</p> <p>This field is used to enter very low power run. Writes to this field are blocked if the protection level has not been enabled using PMPROT register. This field is cleared by hardware on exit from LLS or VLLS modes.</p> <p>00 Normal run mode 01 Reserved 10 Very low power run mode 11 Reserved</p>
4–3 Reserved	<p>This read-only field is reserved and always has the value zero.</p>
2–0 LPLLSM	<p>Low Power, Low Leakage Stop Mode</p> <p>Select low power or low leakage stop modes provided the PMPROT was set properly and stop mode entry via the sleep-now or sleep-on-exit. After any system reset, writes to reconfigure PMPROT clears LPLLSM.</p> <p>000 Normal stop 001 Reserved 010 Very low power stop (VLPS) 011 Low leakage stop (LLS) 100 Reserved 101 Very low leakage stop 3 (VLLS3) 110 Very low leakage stop 2 (VLLS2) 111 Very low leakage stop 1 (VLLS1)</p>

Chapter 14

Power Management Controller

14.1 Introduction

NOTE

For the chip-specific implementation details of this module's instances see the chip configuration chapter.

The PMC contains the internal voltage regulator, power on reset (POR), and low voltage detect system.

The [Mode Controller](#) controls the PMC and its chapter contains description of all device resets, including POR.

14.2 Features

Power management control features include:

- Internal voltage regulator
- Active POR providing brown-out detect
- Low-voltage detect protection including:
 - Multiple programmable trip voltages
 - Warning and detect interrupt control
 - Drive a reset on low voltage detect

14.3 Low-Voltage Detect (LVD) System

This device includes a system to protect against low-voltage conditions to protect memory contents and control MCU system states during supply voltage variations. The system is comprised of a power-on reset (POR) circuit and a LVD circuit with a user-

selectable trip voltage: high ($V_{LV\text{DH}}$) or low ($V_{LV\text{DL}}$). The trip voltage is selected by the LV\text{DSC1}[LV\text{DV}] bits. The LVD is disabled upon entering VLPx, LLS, and VLLSx modes.

Two flags are available to indicate the status of the low-voltage detect system:

- The low voltage detect flag (LV\text{DF}) operates in a level sensitive manner. The LV\text{DF} bit is set when the internal supply voltage falls below the selected internal monitor trip point (VL\text{VD}). The LV\text{DF} bit is cleared by writing one to the LV\text{DACK} bit, but only if the internal supply has returned above the internal trip point; otherwise, the LV\text{DF} bit remains set.
- The low voltage warning flag (LV\text{WF}) operates in a level sensitive manner. The LV\text{WF} bit is set when the internal supply voltage falls below the selected internal monitor trip point (VL\text{VW}). The LV\text{WF} bit is cleared by writing one to the LV\text{WACK} bit, but only if the internal supply has returned above the internal trip point; otherwise, the LV\text{WF} bit remains set.

14.3.1 LVD Reset Operation

By setting the LV\text{DRE} bit, the LVD generates a reset upon detection of a low voltage condition. The low voltage detection threshold is determined by the LV\text{DV} bits. After an LVD reset occurs, the LVD system holds the MCU in reset until the supply voltage rises above this threshold. The LVD bit in the SRS register is set following an LVD or power-on reset.

14.3.2 LVD Interrupt Operation

By configuring the LVD circuit for interrupt operation (LV\text{DIE} set and LV\text{DRE} clear), LV\text{DSC1}[LV\text{DF}] is set and an LVD interrupt request occurs upon detection of a low voltage condition. The LV\text{DF} bit is cleared by writing one to the LV\text{DSC1}[LV\text{DACK}] bit.

14.3.3 Low-Voltage Warning (LVW) Interrupt Operation

The LVD system contains a low voltage warning flag (LV\text{WF}) to indicate that the supply voltage is approaching, but is above, the LVD voltage. The LV\text{W} also has an interrupt, which is enabled by setting the LV\text{DSC2}[LV\text{WIE}] bit. If enabled, an LV\text{W} interrupt request occurs when the LV\text{WF} is set. LV\text{WF} is cleared by writing one to the LV\text{DSC2}[LV\text{WACK}] bit.

The LVDSC2[LVWV] bits select one of four trip voltages:

- Highest (V_{LVW4})
- Two mid-levels (V_{LVW3} and V_{LVW2})
- Lowest (V_{LVW1})

14.4 PMC Memory Map/Register Definition

The following table shows the registers related to the PMC.

See [Mode Control Memory Map/Register Definition](#) for the mode controller registers.

PMC memory map

Absolute address (hex)	Register name	Width (in bits)	Access	Reset value	Section/page
4007_D000	Low Voltage Detect Status and Control 1 Register (PMC_LVDSC1)	8	R/W	10h	14.4.1/313
4007_D001	Low Voltage Detect Status and Control 2 Register (PMC_LVDSC2)	8	R/W	00h	14.4.2/314
4007_D002	Regulator Status and Control Register (PMC_REGSC)	8	R/W	04h	14.4.3/316

14.4.1 Low Voltage Detect Status and Control 1 Register (PMC_LVDSC1)

This register contains status and control bits to support the low voltage detect function. This register should be written during the reset initialization program to set the desired controls even if the desired settings are the same as the reset settings.

While the device is in the very low power or low leakage modes, the LVD system is disabled regardless of LVDSC1 settings. To protect systems that must have LVD always on, configure the power mode protection register (PMPROT) to disallow any very low power or low leakage modes from being enabled.

See the device's data sheet for the exact LVD trip voltages.

NOTE

The reset value of this register depends on the reset type:

- POR -- 0x10
- Other reset -- bit 4 is set, bits 1-0 are unaffected

PMC Memory Map/Register Definition

Address: PMC_LVDSC1 is 4007_D000h base + 0h offset = 4007_D000h

Bit	7	6	5	4	3	2	1	0
Read	LVDF	0	LVDIE	LVDRE	0		LVDV	
Write		LVDACK						
Reset	0	0	0	1	0	0	0	0

PMC_LVDSC1 field descriptions

Field	Description
7 LVDF	<p>Low-Voltage Detect Flag</p> <p>This read-only status bit indicates a low-voltage detect event.</p> <p>0 Low-voltage event not detected 1 Low-voltage event detected</p>
6 LVDACK	<p>Low-Voltage Detect Acknowledge</p> <p>This write-only bit is used to acknowledge low voltage detection errors (write 1 to clear LVDF). Reads always return 0.</p>
5 LVDIE	<p>Low-Voltage Detect Interrupt Enable</p> <p>Enables hardware interrupt requests for LVDF.</p> <p>0 Hardware interrupt disabled (use polling) 1 Request a hardware interrupt when LVDF = 1.</p>
4 LVDRE	<p>Low-Voltage Detect Reset Enable</p> <p>This write-once bit enables LVDF events to generate a hardware reset. Additional writes are ignored.</p> <p>0 LVDF does not generate hardware resets 1 Force an MCU reset when LVDF = 1</p>
3–2 Reserved	<p>This read-only field is reserved and always has the value zero.</p>
1–0 LVDV	<p>Low-Voltage Detect Voltage Select</p> <p>Selects the LVD trip point voltage (V_{LVD}).</p> <p>00 Low trip point selected ($V_{LVD} = V_{LVDL}$) 01 High trip point selected ($V_{LVD} = V_{LVDH}$) 10 Reserved 11 Reserved</p>

14.4.2 Low Voltage Detect Status and Control 2 Register (PMC_LVDSC2)

This register contains status and control bits to support the low voltage warning function.

While the device is in the very low power or low leakage modes, the LVD system is disabled regardless of LVDSC2 settings.

See the device's data sheet for the exact LVD trip voltages.

NOTE

The LVW trip voltages depend on LVWV and LVDV bits.

NOTE

The reset value of this register depends on the reset type:

- POR -- 0x00
- Other reset -- bits 1-0 are unaffected

Address: PMC_LVDSC2 is 4007_D000h base + 1h offset = 4007_D001h

Bit	7	6	5	4	3	2	1	0
Read	LVWF	0	LVWIE	0			LVWV	
Write		LVWACK						
Reset	0	0	0	0	0	0	0	0

PMC_LVDSC2 field descriptions

Field	Description
7 LVWF	<p>Low-Voltage Warning Flag</p> <p>This read-only status bit indicates a low-voltage warning event. LVWF is set when V_{Supply} transitions below the trip point or after reset and V_{Supply} is already below V_{LVW}.</p> <p>0 Low-voltage warning event not detected 1 Low-voltage warning event detected</p>
6 LVWACK	<p>Low-Voltage Warning Acknowledge</p> <p>This write-only bit is used to acknowledge low voltage warning errors (write 1 to clear LVWF). Reads always return 0.</p>
5 LVWIE	<p>Low-Voltage Warning Interrupt Enable</p> <p>Enables hardware interrupt requests for LVWF.</p> <p>0 Hardware interrupt disabled (use polling) 1 Request a hardware interrupt when LVWF = 1.</p>
4–2 Reserved	<p>This read-only field is reserved and always has the value zero.</p>
1–0 LVWV	<p>Low-Voltage Warning Voltage Select</p> <p>Selects the LVW trip point voltage (V_{LVW}). The actual voltage for the warning depends on LVDSC1[LVDV].</p> <p>00 Low trip point selected ($V_{LVW} = V_{LVW1H/L}$) 01 Mid 1 trip point selected ($V_{LVW} = V_{LVW2H/L}$) 10 Mid 2 trip point selected ($V_{LVW} = V_{LVW3H/L}$) 11 High trip point selected ($V_{LVW} = V_{LVW4H/L}$)</p>

14.4.3 Regulator Status and Control Register (PMC_REGSC)

The power management controller contains an internal voltage regulator. The voltage regulator design uses a bandgap reference, that is also available through a buffer as input to certain internal peripherals. The internal regulator provides a status bit (REGONS) indicating the regulator is in run regulation. This bit is used when the application moves from a low power or very low power mode where the frequency is limited to normal run mode. The frequency of the application can not be increased until the regulator is back in run regulation (REGONS=1).

Address: PMC_REGSC is 4007_D000h base + 2h offset = 4007_D002h

Bit	7	6	5	4	3	2	1	0
Read	0			TRAMPO	VLPRS	REGONS		BGBE
Write							0	
Reset	0	0	0	0	0	1	0	0

PMC_REGSC field descriptions

Field	Description
7–5 Reserved	This read-only field is reserved and always has the value zero.
4 TRAMPO	Reserved 0 No effect 1 No effect
3 VLPRS	Very Low Power Run Status This read only bit indicates the current run mode is VLPR. 0 MCU is not in VLPR mode 1 MCU is in VLPR mode
2 REGONS	Regulator in Run Regulation Status This read-only bit provides the current status of the internal voltage regulator. 0 Regulator is in stop regulation or in transition to/from it 1 Regulator is in run regulation
1 Reserved	This field is reserved.
0 BGBE	Bandgap Buffer Enable Enables the bandgap buffer. 0 Bandgap buffer not enabled 1 Bandgap buffer enabled

Chapter 15

Low-leakage wake-up unit (LLWU)

15.1 Introduction

NOTE

For the chip-specific implementation details of this module's instances see the chip configuration chapter.

The LLWU module allows the user to select up to 16 external pin sources and up to 7 internal modules as a wakeup source from low-leakage power modes (LLS and VLLS). The input sources vary by device and are described in the specific device's Chip Configuration details. Each of the available wakeup sources can be individually enabled.

The $\overline{\text{RESET}}$ pin is an additional source for triggering an exit from low-leakage power modes and causes the MCU to exit both LLS and VLLS through a reset flow. On MCUs where the $\overline{\text{RESET}}$ pin is shared with other functions, the explicit port mux control register must be set for $\overline{\text{RESET}}$ pin before the $\overline{\text{RESET}}$ pin can be used as a low-leakage reset source.

When in LLS mode, the I/O are released immediately on a wakeup or reset event. In the case of LLS exit via a $\overline{\text{RESET}}$ pin, the I/O default to their reset state.

When in VLLS modes, the I/O states are held on a wakeup event until the wakeup has been acknowledged via a write to the ACKISO bit. In the case of VLLS exit via a $\overline{\text{RESET}}$ pin, the I/O are released and default to their reset state. In this case, no write to the ACKISO is needed.

In both LLS mode exits via $\overline{\text{RESET}}$ pin and any VLLS mode via a wakeup or reset event, the MC_SRS[WAKEUP] is set indicating the low-leakage mode was active prior to the last system reset flow. Using the $\overline{\text{RESET}}$ pin to trigger an exit from LLS or VLLS results in the MC_SRS[PIN] being set as well.

The LLWU module also includes two optional digital pin filters. One for the external wakeup pins combined and one for the $\overline{\text{RESET}}$ pin.

15.1.1 Features

The LLWU module features include:

- Supports up to 16 external input pins and up to 7 internal modules with individual enable bits
- Input sources may be external pins or from internal peripherals capable of running in LLS or VLLS. See the Chip Configuration details for wakeup input sources for this device.
- Each external pin wakeup input is programmable as falling edge, rising edge, or any change
- Each internal module wakeup input source qualified with programmable enable
- Wakeup inputs are activated if enabled once MCU enters low leakage stop (LLS) or very low leakage stop (VLLS) modes
- Reset exit due to assertion of $\overline{\text{RESET}}$ pin via reset flow. I/O states are reset on exit
- Wakeup from LLS mode is handled as an interrupt. I/O states are released on exit
- Wakeup exit via reset flow when MCU is in VLLS. I/O states remain in held state until wakeup has been acknowledged.
- An optional digital filter provided to qualify an external pin detect and $\overline{\text{RESET}}$ pin detect.

15.1.2 Modes of operation

The LLWU module is only functional in LLS and VLLS modes.

15.1.2.1 LLS mode

The LLWU module provides up to 16 external wakeup inputs and up to seven internal module wakeup inputs. In addition, an LLS reset event can be initiated via assertion of the $\overline{\text{RESET}}$ pin.

Wakeup events due to external wakeup inputs and internal module wakeup inputs result in an interrupt flow when exiting LLS. A reset event due to $\overline{\text{RESET}}$ pin assertion results in a reset flow when exiting LLS.

NOTE

The LLWU interrupt must not be masked by the interrupt controller to avoid a scenario where the system does not fully exit stop mode on an LLS recovery.

15.1.2.2 VLLS modes

The LLWU module provides up to 16 external wakeup inputs and up to seven internal module wakeup inputs. In addition, a VLLS reset event can be initiated via assertion of the $\overline{\text{RESET}}$ pin. All wakeup and reset events result in VLLS exit via a reset flow.

15.1.2.3 Non-low leakage modes

The LLWU is not active in all non-LLS and VLLS modes where detection and control logic are in a static state. The LLWU registers are accessible in non-LLS and VLLS modes and are available for configuring and reading status when bus transactions are possible.

When the reset pin filter is enabled, filter operation begins immediately so that if LLS or VLLS modes are entered while the filter logic has seen an active edge on the RESET pin and is currently sensing for minimum assertion duration, there is no restart of pin filtering as RESET filtering transitions from a non-low leakage filter operation (implemented external to LLWU) to the RESET pin filter circuit implemented in the LLWU.

15.1.2.4 Debug mode

In debug mode, when LLS/VLLS modes are entered, the chip enters fully functional VLLS and LLS modes and no debug logic is working; on exit from LLS/VLLS, the LLWU becomes inactive and the debug logic becomes active again.

15.1.3 Block diagram

The following figure is the block diagram for the LLWU module.

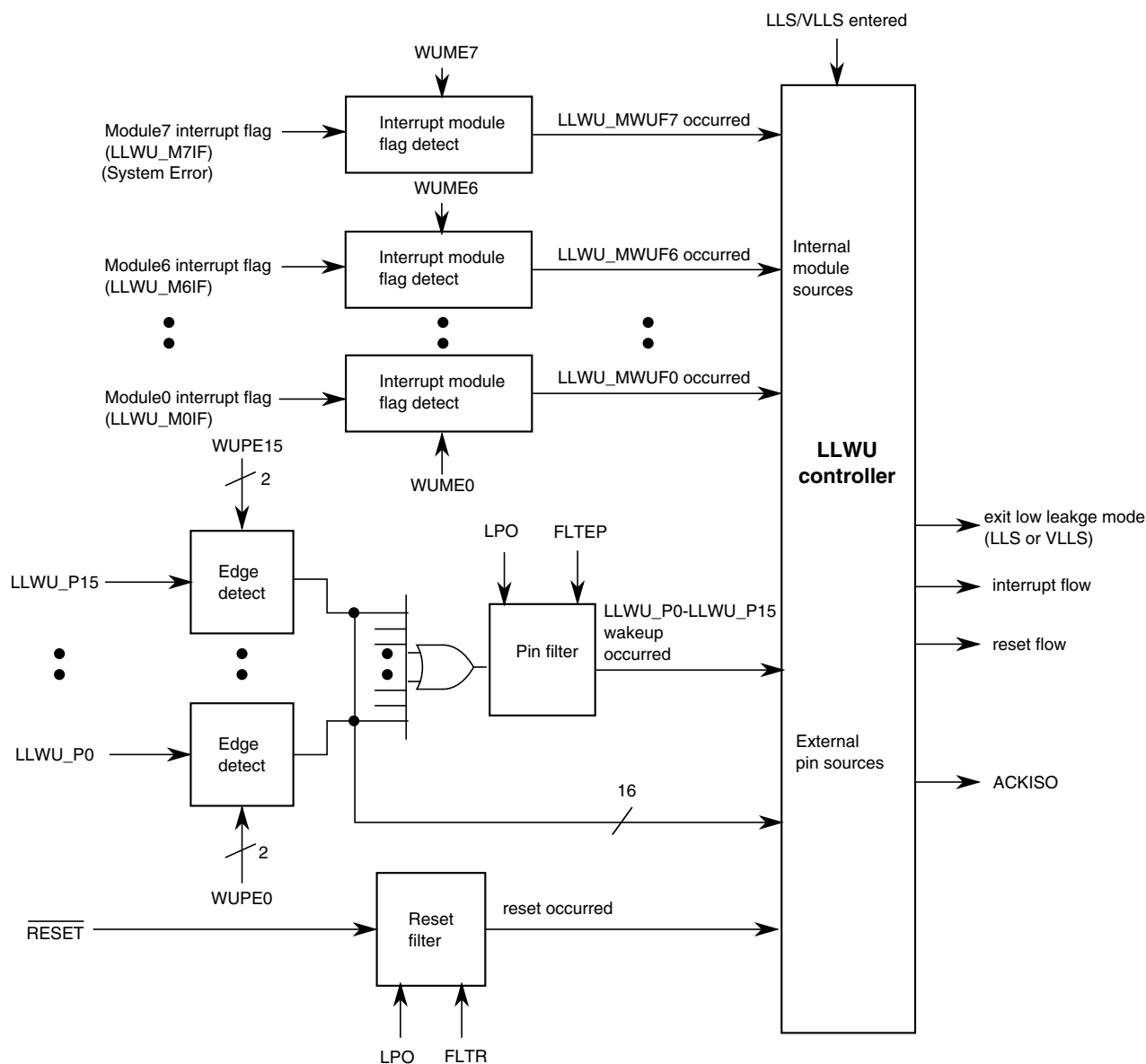

Figure 15-1. LLWU block diagram

15.2 LLWU Signal Descriptions

The signal properties of LLWU are shown in the following table. The external wakeup input pins can be enabled to detect either rising edge, falling edge, or on any change.

Table 15-1. LLWU Signal Descriptions

Signal	Description	I/O
LLWU_Pn	Wakeup inputs (n = 0-15)	I

15.3 Memory map/register definition

The LLWU includes the following registers:

- Five 8-bit wakeup source enable registers
 - Enable external pin input sources
 - Enable internal peripheral sources
- Three 8-bit wakeup flag registers
 - Indication of wakeup up source that caused exit from LLS or VLLS includes external pin or internal module interrupt
- One 8-bit status and control register
 - Digital filter enable for external pin detected and reset
 - Low leakage reset pin enable
 - Acknowledge bit to allow certain peripherals and pads to release their held low leakage state

LLWU memory map

Absolute address (hex)	Register name	Width (in bits)	Access	Reset value	Section/page
4007_C000	LLWU Pin Enable 1 Register (LLWU_PE1)	8	R/W	00h	15.3.1/321
4007_C001	LLWU Pin Enable 2 Register (LLWU_PE2)	8	R/W	00h	15.3.2/322
4007_C002	LLWU Pin Enable 3 Register (LLWU_PE3)	8	R/W	00h	15.3.3/324
4007_C003	LLWU Pin Enable 4 Register (LLWU_PE4)	8	R/W	00h	15.3.4/325
4007_C004	LLWU Module Enable Register (LLWU_ME)	8	R/W	00h	15.3.5/326
4007_C005	LLWU Flag 1 Register (LLWU_F1)	8	R/W	00h	15.3.6/327
4007_C006	LLWU Flag 2 Register (LLWU_F2)	8	R/W	00h	15.3.7/329
4007_C007	LLWU Flag 3 Register (LLWU_F3)	8	R/W	00h	15.3.8/331
4007_C008	LLWU Control and Status Register (LLWU_CS)	8	R/W	04h	15.3.9/332

15.3.1 LLWU Pin Enable 1 Register (LLWU_PE1)

LLWU_PE1 contains the bit field to enable and select the edge detect type for the external wakeup input pins LLWU_P3-LLWU_P0.

NOTE

This register is unaffected by wakeup from low leakage modes (exit from LLS via $\overline{\text{RESET}}$ or any exit from VLLS).

memory map/register definition

Address: LLWU_PE1 is 4007_C000h base + 0h offset = 4007_C000h

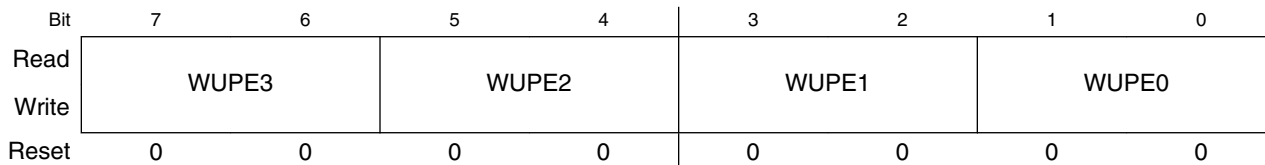

LLWU_PE1 field descriptions

Field	Description
7-6 WUPE3	<p>Wakeup Pin Enable for LLWU_P3</p> <p>Enables and configures the edge detection for the wakeup pin.</p> <p>00 External input pin disabled as wakeup input 01 External input pin enabled with rising edge detection 10 External input pin enabled with falling edge detection 11 External input pin enabled with any change detection</p>
5-4 WUPE2	<p>Wakeup Pin Enable for LLWU_P2</p> <p>Enables and configures the edge detection for the wakeup pin.</p> <p>00 External input pin disabled as wakeup input 01 External input pin enabled with rising edge detection 10 External input pin enabled with falling edge detection 11 External input pin enabled with any change detection</p>
3-2 WUPE1	<p>Wakeup Pin Enable for LLWU_P1</p> <p>Enables and configures the edge detection for the wakeup pin.</p> <p>00 External input pin disabled as wakeup input 01 External input pin enabled with rising edge detection 10 External input pin enabled with falling edge detection 11 External input pin enabled with any change detection</p>
1-0 WUPE0	<p>Wakeup Pin Enable for LLWU_P0</p> <p>Enables and configures the edge detection for the wakeup pin.</p> <p>00 External input pin disabled as wakeup input 01 External input pin enabled with rising edge detection 10 External input pin enabled with falling edge detection 11 External input pin enabled with any change detection</p>

15.3.2 LLWU Pin Enable 2 Register (LLWU_PE2)

LLWU_PE2 contains the bit field to enable and select the edge detect type for the external wakeup input pins LLWU_P7-LLWU_P4.

NOTE

This register is unaffected by wakeup from low leakage modes (exit from LLS via $\overline{\text{RESET}}$ or any exit from VLLS).

Address: LLWU_PE2 is 4007_C000h base + 1h offset = 4007_C001h

Bit	7	6	5	4	3	2	1	0
Read	WUPE7		WUPE6		WUPE5		WUPE4	
Write								
Reset	0	0	0	0	0	0	0	0

LLWU_PE2 field descriptions

Field	Description
7–6 WUPE7	<p>Wakeup Pin Enable for LLWU_P7</p> <p>Enables and configures the edge detection for the wakeup pin.</p> <p>00 External input pin disabled as wakeup input 01 External input pin enabled with rising edge detection 10 External input pin enabled with falling edge detection 11 External input pin enabled with any change detection</p>
5–4 WUPE6	<p>Wakeup Pin Enable for LLWU_P6</p> <p>Enables and configures the edge detection for the wakeup pin.</p> <p>00 External input pin disabled as wakeup input 01 External input pin enabled with rising edge detection 10 External input pin enabled with falling edge detection 11 External input pin enabled with any change detection</p>
3–2 WUPE5	<p>Wakeup Pin Enable for LLWU_P5</p> <p>Enables and configures the edge detection for the wakeup pin.</p> <p>00 External input pin disabled as wakeup input 01 External input pin enabled with rising edge detection 10 External input pin enabled with falling edge detection 11 External input pin enabled with any change detection</p>
1–0 WUPE4	<p>Wakeup Pin Enable for LLWU_P4</p> <p>Enables and configures the edge detection for the wakeup pin.</p> <p>00 External input pin disabled as wakeup input 01 External input pin enabled with rising edge detection 10 External input pin enabled with falling edge detection 11 External input pin enabled with any change detection</p>

15.3.3 LLWU Pin Enable 3 Register (LLWU_PE3)

LLWU_PE3 contains the bit field to enable and select the edge detect type for the external wakeup input pins LLWU_P11-LLWU_P8.

NOTE

This register is unaffected by wakeup from low leakage modes (exit from LLS via $\overline{\text{RESET}}$ or any exit from VLLS).

Address: LLWU_PE3 is 4007_C000h base + 2h offset = 4007_C002h

Bit	7	6	5	4	3	2	1	0
Read	WUPE11		WUPE10		WUPE9		WUPE8	
Write	WUPE11		WUPE10		WUPE9		WUPE8	
Reset	0	0	0	0	0	0	0	0

LLWU_PE3 field descriptions

Field	Description
7-6 WUPE11	<p>Wakeup Pin Enable for LLWU_P11</p> <p>Enables and configures the edge detection for the wakeup pin.</p> <p>00 External input pin disabled as wakeup input 01 External input pin enabled with rising edge detection 10 External input pin enabled with falling edge detection 11 External input pin enabled with any change detection</p>
5-4 WUPE10	<p>Wakeup Pin Enable for LLWU_P10</p> <p>Enables and configures the edge detection for the wakeup pin.</p> <p>00 External input pin disabled as wakeup input 01 External input pin enabled with rising edge detection 10 External input pin enabled with falling edge detection 11 External input pin enabled with any change detection</p>
3-2 WUPE9	<p>Wakeup Pin Enable for LLWU_P9</p> <p>Enables and configures the edge detection for the wakeup pin.</p> <p>00 External input pin disabled as wakeup input 01 External input pin enabled with rising edge detection 10 External input pin enabled with falling edge detection 11 External input pin enabled with any change detection</p>
1-0 WUPE8	<p>Wakeup Pin Enable for LLWU_P8</p> <p>Enables and configures the edge detection for the wakeup pin.</p> <p>00 External input pin disabled as wakeup input 01 External input pin enabled with rising edge detection</p>

Table continues on the next page...

LLWU_PE3 field descriptions (continued)

Field	Description
10	External input pin enabled with falling edge detection
11	External input pin enabled with any change detection

15.3.4 LLWU Pin Enable 4 Register (LLWU_PE4)

LLWU_PE4 contains the bit field to enable and select the edge detect type for the external wakeup input pins LLWU_P15-LLWU_P12.

NOTE

This register is unaffected by wakeup from low leakage modes (exit from LLS via $\overline{\text{RESET}}$ or any exit from VLLS).

Address: LLWU_PE4 is 4007_C000h base + 3h offset = 4007_C003h

Bit	7	6	5	4	3	2	1	0
Read	WUPE15		WUPE14		WUPE13		WUPE12	
Write	WUPE15		WUPE14		WUPE13		WUPE12	
Reset	0	0	0	0	0	0	0	0

LLWU_PE4 field descriptions

Field	Description
7-6 WUPE15	Wakeup Pin Enable for LLWU_P15 Enables and configures the edge detection for the wakeup pin. 00 External input pin disabled as wakeup input 01 External input pin enabled with rising edge detection 10 External input pin enabled with falling edge detection 11 External input pin enabled with any change detection
5-4 WUPE14	Wakeup Pin Enable for LLWU_P14 Enables and configures the edge detection for the wakeup pin. 00 External input pin disabled as wakeup input 01 External input pin enabled with rising edge detection 10 External input pin enabled with falling edge detection 11 External input pin enabled with any change detection
3-2 WUPE13	Wakeup Pin Enable for LLWU_P13 Enables and configures the edge detection for the wakeup pin. 00 External input pin disabled as wakeup input 01 External input pin enabled with rising edge detection

Table continues on the next page...

LLWU_PE4 field descriptions (continued)

Field	Description
	10 External input pin enabled with falling edge detection 11 External input pin enabled with any change detection
1-0 WUPE12	Wakeup Pin Enable for LLWU_P12 Enables and configures the edge detection for the wakeup pin. 00 External input pin disabled as wakeup input 01 External input pin enabled with rising edge detection 10 External input pin enabled with falling edge detection 11 External input pin enabled with any change detection

15.3.5 LLWU Module Enable Register (LLWU_ME)

LLWU_ME contains the bits to enable the internal module flag as a wakeup input source for inputs MWUF7-MWUF0.

NOTE

This register is unaffected by wakeup from low leakage modes (exit from LLS via $\overline{\text{RESET}}$ or any exit from VLLS).

Address: LLWU_ME is 4007_C000h base + 4h offset = 4007_C004h

Bit	7	6	5	4	3	2	1	0
Read	WUME7	WUME6	WUME5	WUME4	WUME3	WUME2	WUME1	WUME0
Write								
Reset	0	0	0	0	0	0	0	0

LLWU_ME field descriptions

Field	Description
7 WUME7	Wakeup Module Enable for Module 7 Enables an internal module as a wakeup source input. 0 Internal module flag not used as wakeup source 1 Internal module flag used as wakeup source
6 WUME6	Wakeup Module Enable for Module 6 Enables an internal module as a wakeup source input. 0 Internal module flag not used as wakeup source 1 Internal module flag used as wakeup source
5 WUME5	Wakeup Module Enable for Module 5 Enables an internal module as a wakeup source input.

Table continues on the next page...

LLWU_ME field descriptions (continued)

Field	Description
	0 Internal module flag not used as wakeup source 1 Internal module flag used as wakeup source
4 WUME4	Wakeup Module Enable for Module 4 Enables an internal module as a wakeup source input. 0 Internal module flag not used as wakeup source 1 Internal module flag used as wakeup source
3 WUME3	Wakeup Module Enable for Module 3 Enables an internal module as a wakeup source input. 0 Internal module flag not used as wakeup source 1 Internal module flag used as wakeup source
2 WUME2	Wakeup Module Enable for Module 2 Enables an internal module as a wakeup source input. 0 Internal module flag not used as wakeup source 1 Internal module flag used as wakeup source
1 WUME1	Wakeup Module Enable for Module 1 Enables an internal module as a wakeup source input. 0 Internal module flag not used as wakeup source 1 Internal module flag used as wakeup source
0 WUME0	Wakeup Module Enable for Module 0 Enables an internal module as a wakeup source input. 0 Internal module flag not used as wakeup source 1 Internal module flag used as wakeup source

15.3.6 LLWU Flag 1 Register (LLWU_F1)

LLWU_F1 contains the wakeup flags indicating which wakeup source caused the MCU to exit LLS or VLLS mode. For LLS, this will be the source causing the CPU interrupt flow. For VLLS, this will be the source causing the MCU reset flow.

The external wakeup flags are read only and clearing a flag is accomplished by a write of a one to the corresponding WUFx bit. The wakeup flag (WUFx) if set will remain set if the associated WUPEx bit is cleared.

NOTE

This register is unaffected by wakeup from low leakage modes (exit from LLS via $\overline{\text{RESET}}$ or any exit from VLLS).

memory map/register definition

Address: LLWU_F1 is 4007_C000h base + 5h offset = 4007_C005h

Bit	7	6	5	4	3	2	1	0
Read	WUF7	WUF6	WUF5	WUF4	WUF3	WUF2	WUF1	WUF0
Write	w1c	w1c	w1c	w1c	w1c	w1c	w1c	w1c
Reset	0	0	0	0	0	0	0	0

LLWU_F1 field descriptions

Field	Description
7 WUF7	<p>Wakeup Flag for LLWU_P7</p> <p>Indicates that an enabled external wakeup pin was a source of exiting LLS or VLLS. To clear the flag write a one to WUF7.</p> <p>0 LLWU_P7 input was not a source of wakeup from LLS or VLLS mode 1 LLWU_P7 input was a source of wakeup from LLS or VLLS mode</p>
6 WUF6	<p>Wakeup Flag for LLWU_P6</p> <p>Indicates that an enabled external wakeup pin was a source of exiting LLS or VLLS. To clear the flag write a one to WUF6.</p> <p>0 LLWU_P6 input was not a source of wakeup from LLS or VLLS mode 1 LLWU_P6 input was a source of wakeup from LLS or VLLS mode</p>
5 WUF5	<p>Wakeup Flag for LLWU_P5</p> <p>Indicates that an enabled external wakeup pin was a source of exiting LLS or VLLS. To clear the flag write a one to WUF5.</p> <p>0 LLWU_P5 input was not a source of wakeup from LLS or VLLS mode 1 LLWU_P5 input was a source of wakeup from LLS or VLLS mode</p>
4 WUF4	<p>Wakeup Flag for LLWU_P4</p> <p>Indicates that an enabled external wakeup pin was a source of exiting LLS or VLLS. To clear the flag write a one to WUF4.</p> <p>0 LLWU_P4 input was not a source of wakeup from LLS or VLLS mode 1 LLWU_P4 input was a source of wakeup from LLS or VLLS mode</p>
3 WUF3	<p>Wakeup Flag for LLWU_P3</p> <p>Indicates that an enabled external wakeup pin was a source of exiting LLS or VLLS. To clear the flag write a one to WUF3.</p> <p>0 LLWU_P3 input was not a source of wakeup from LLS or VLLS mode 1 LLWU_P3 input was a source of wakeup from LLS or VLLS mode</p>
2 WUF2	<p>Wakeup Flag for LLWU_P2</p> <p>Indicates that an enabled external wakeup pin was a source of exiting LLS or VLLS. To clear the flag write a one to WUF2.</p> <p>0 LLWU_P2 input was not a source of wakeup from LLS or VLLS mode 1 LLWU_P2 input was a source of wakeup from LLS or VLLS mode</p>

Table continues on the next page...

LLWU_F1 field descriptions (continued)

Field	Description
1 WUF1	Wakeup Flag for LLWU_P1 Indicates that an enabled external wakeup pin was a source of exiting LLS or VLLS. To clear the flag write a one to WUF1. 0 LLWU_P1 input was not a source of wakeup from LLS or VLLS mode 1 LLWU_P1 input was a source of wakeup from LLS or VLLS mode
0 WUF0	Wakeup Flag for LLWU_P0 Indicates that an enabled external wakeup pin was a source of exiting LLS or VLLS. To clear the flag write a one to WUF0. 0 LLWU_P0 input was not a source of wakeup from LLS or VLLS mode 1 LLWU_P0 input was a source of wakeup from LLS or VLLS mode

15.3.7 LLWU Flag 2 Register (LLWU_F2)

LLWU_F2 contains the wakeup flags indicating which wakeup source caused the MCU to exit LLS or VLLS mode. For LLS, this will be the source causing the CPU interrupt flow. For VLLS, this will be the source causing the MCU reset flow.

The external wakeup flags are read only and clearing a flag is accomplished by a write of a one to the corresponding WUFx bit. The wakeup flag (WUFx) if set will remain set if the associated WUPEx bit is cleared.

NOTE

This register is unaffected by wakeup from low leakage modes (exit from LLS via $\overline{\text{RESET}}$ or any exit from VLLS).

Address: LLWU_F2 is 4007_C000h base + 6h offset = 4007_C006h

Bit	7	6	5	4	3	2	1	0
Read	WUF15	WUF14	WUF13	WUF12	WUF11	WUF10	WUF9	WUF8
Write	w1c	w1c	w1c	w1c	w1c	w1c	w1c	w1c
Reset	0	0	0	0	0	0	0	0

LLWU_F2 field descriptions

Field	Description
7 WUF15	Wakeup Flag for LLWU_P15 Indicates that an enabled external wakeup pin was a source of exiting LLS or VLLS. To clear the flag write a one to WUF15.

Table continues on the next page...

LLWU_F2 field descriptions (continued)

Field	Description
	0 LLWU_P15 input was not a source of wakeup from LLS or VLLS mode 1 LLWU_P15 input was a source of wakeup from LLS or VLLS mode
6 WUF14	Wakeup Flag for LLWU_P14 Indicates that an enabled external wakeup pin was a source of exiting LLS or VLLS. To clear the flag write a one to WUF14. 0 LLWU_P14 input was not a source of wakeup from LLS or VLLS mode 1 LLWU_P14 input was a source of wakeup from LLS or VLLS mode
5 WUF13	Wakeup Flag for LLWU_P13 Indicates that an enabled external wakeup pin was a source of exiting LLS or VLLS. To clear the flag write a one to WUF13. 0 LLWU_P13 input was not a source of wakeup from LLS or VLLS mode 1 LLWU_P13 input was a source of wakeup from LLS or VLLS mode
4 WUF12	Wakeup Flag for LLWU_P12 Indicates that an enabled external wakeup pin was a source of exiting LLS or VLLS. To clear the flag write a one to WUF12. 0 LLWU_P12 input was not a source of wakeup from LLS or VLLS mode 1 LLWU_P12 input was a source of wakeup from LLS or VLLS mode
3 WUF11	Wakeup Flag for LLWU_P11 Indicates that an enabled external wakeup pin was a source of exiting LLS or VLLS. To clear the flag write a one to WUF11. 0 LLWU_P11 input was not a source of wakeup from LLS or VLLS mode 1 LLWU_P11 input was a source of wakeup from LLS or VLLS mode
2 WUF10	Wakeup Flag for LLWU_P10 Indicates that an enabled external wakeup pin was a source of exiting LLS or VLLS. To clear the flag write a one to WUF10. 0 LLWU_P10 input was not a source of wakeup from LLS or VLLS mode 1 LLWU_P10 input was a source of wakeup from LLS or VLLS mode
1 WUF9	Wakeup Flag for LLWU_P9 Indicates that an enabled external wakeup pin was a source of exiting LLS or VLLS. To clear the flag write a one to WUF9. 0 LLWU_P9 input was not a source of wakeup from LLS or VLLS mode 1 LLWU_P9 input was a source of wakeup from LLS or VLLS mode
0 WUF8	Wakeup Flag for LLWU_P8 Indicates that an enabled external wakeup pin was a source of exiting LLS or VLLS. To clear the flag write a one to WUF8. 0 LLWU_P8 input was not a source of wakeup from LLS or VLLS mode 1 LLWU_P8 input was a source of wakeup from LLS or VLLS mode

15.3.8 LLWU Flag 3 Register (LLWU_F3)

LLWU_F3 contains the wakeup flags indicating which internal wakeup source caused the MCU to exit LLS or VLLS mode. For LLS, this will be the source causing the CPU interrupt flow. For VLLS, this will be the source causing the MCU reset flow.

For internal peripherals that are capable of running in LLS or VLLS mode, such as RTC or CMP modules, the flag from the associated peripheral is accessible as the MWUFx bit. Clearing of the flag will need to be done in the peripheral instead of writing a one to the MWUFx bit.

NOTE

This register is unaffected by wakeup from low leakage modes (exit from LLS via RESET or any exit from VLLS).

Address: LLWU_F3 is 4007_C000h base + 7h offset = 4007_C007h

Bit	7	6	5	4	3	2	1	0
Read	MWUF7	MWUF6	MWUF5	MWUF4	MWUF3	MWUF2	MWUF1	MWUF0
Write	w1c							
Reset	0	0	0	0	0	0	0	0

LLWU_F3 field descriptions

Field	Description
7 MWUF7	<p>Wakeup flag for module 7 (Error Detect)</p> <p>Indicates that an unexpected source of wakeup was active when LLS or VLLS was entered. An immediate wakeup event was triggered and the source of the wakeup event is not known. Error handling routines should treat this source as an unknown wakeup. To clear the flag write a one to MWUF7.</p> <p>0 Module 7 (Error Detect) input was not a source of wakeup from LLS or VLLS mode 1 Module 7 (Error Detect) input was a source of wakeup from LLS or VLLS mode</p>
6 MWUF6	<p>Wakeup flag for module 6</p> <p>Indicates that an enabled internal peripheral was a source of exiting LLS or VLLS. To clear the flag follow the internal peripheral flag clearing mechanism.</p> <p>0 Module 6 input was not a source of wakeup from LLS or VLLS mode 1 Module 6 input was a source of wakeup from LLS or VLLS mode</p>
5 MWUF5	<p>Wakeup flag for module 5</p> <p>Indicates that an enabled internal peripheral was a source of exiting LLS or VLLS. To clear the flag follow the internal peripheral flag clearing mechanism.</p> <p>0 Module 5 input was not a source of wakeup from LLS or VLLS mode 1 Module 5 input was a source of wakeup from LLS or VLLS mode</p>

Table continues on the next page...

LLWU_F3 field descriptions (continued)

Field	Description
4 MWUF4	<p>Wakeup flag for module 4</p> <p>Indicates that an enabled internal peripheral was a source of exiting LLS or VLLS. To clear the flag follow the internal peripheral flag clearing mechanism.</p> <p>0 Module 4 input was not a source of wakeup from LLS or VLLS mode 1 Module 4 input was a source of wakeup from LLS or VLLS mode</p>
3 MWUF3	<p>Wakeup flag for module 3</p> <p>Indicates that an enabled internal peripheral was a source of exiting LLS or VLLS. To clear the flag follow the internal peripheral flag clearing mechanism.</p> <p>0 Module 3 input was not a source of wakeup from LLS or VLLS mode 1 Module 3 input was a source of wakeup from LLS or VLLS mode</p>
2 MWUF2	<p>Wakeup flag for module 2</p> <p>Indicates that an enabled internal peripheral was a source of exiting LLS or VLLS. To clear the flag follow the internal peripheral flag clearing mechanism.</p> <p>0 Module 2 input was not a source of wakeup from LLS or VLLS mode 1 Module 2 input was a source of wakeup from LLS or VLLS mode</p>
1 MWUF1	<p>Wakeup flag for module 1</p> <p>Indicates that an enabled internal peripheral was a source of exiting LLS or VLLS. To clear the flag follow the internal peripheral flag clearing mechanism.</p> <p>0 Module 1 input was not a source of wakeup from LLS or VLLS mode 1 Module 1 input was a source of wakeup from LLS or VLLS mode</p>
0 MWUF0	<p>Wakeup flag for module 0</p> <p>Indicates that an enabled internal peripheral was a source of exiting LLS or VLLS. To clear the flag follow the internal peripheral flag clearing mechanism.</p> <p>0 Module 0 input was not a source of wakeup from LLS or VLLS mode 1 Module 0 input was a source of wakeup from LLS or VLLS mode</p>

15.3.9 LLWU Control and Status Register (LLWU_CS)

LLWU_CS is a status and control register that is used to enable/disable the digital filter for the external pin detect and RESET pin.

NOTE

ACKISO is set following wakeup from VLLS modes. FLTEP and FLTR are unaffected following wakeup from low leakage modes (exit from LLS via RESET or any exit from VLLS).

Address: LLWU_CS is 4007_C000h base + 8h offset = 4007_C008h

Bit	7	6	5	4	3	2	1	0
Read	ACKISO	0					FLTEP	FLTR
Write	w1c				1			
Reset	0	0	0	0	0	1	0	0

LLWU_CS field descriptions

Field	Description
7 ACKISO	<p>Acknowledge Isolation</p> <p>Reading this bit indicates whether certain peripherals and the I/O pads are in a latched state as a result of having been in a VLLS mode. Writing one to this bit when it is set releases the I/O pads and certain peripherals to their normal run mode state.</p> <p>0 Peripherals and I/O pads are in normal run state 1 Certain peripherals and I/O pads are in an isolated and latched state</p>
6–3 Reserved	This read-only field is reserved and always has the value zero.
2 Reserved	This field is reserved.
1 FLTEP	<p>Digital Filter on External Pin</p> <p>Enables the digital filter for the external pin detect.</p> <p>0 Filter not enabled 1 Filter enabled</p>
0 FLTR	<p>Digital Filter on RESET Pin</p> <p>Enables the digital filter for the RESET pin during LLS and VLLS modes.</p> <p>0 Filter not enabled 1 Filter enabled</p>

15.4 Functional description

This on-chip peripheral module is called a low leakage wake up (LLWU) module because it allows internal peripherals and external input pins to be sources of wakeup from low leakage modes. It is only operational in LLS and VLLS modes.

The LLWU module contains pin enables for each external pin and internal module. For each external pin, the user can disable or select the edge type for the wakeup. Choices are falling, rising or either edge (any change). When an external pin is enabled as a wakeup source the pin must be configured as an input pin.

The LLWU implements an optional 3-cycle glitch filter, based on the LPO clock, such that a detected external pin is required to stay asserted until the enabled glitch filter times out. There is also 2 additional cycles of latency due to synchronization that results in a total of 5 cycles of delay before the detect circuit alerts the system to the wakeup or reset event when the filter function is enabled. The wakeup detect glitch filter is implemented on the "OR" of external pin inputs of all enabled external pins. There is separate reset glitch filter implemented on the RESET pin. There is no glitch filtering on the internal modules.

NOTE

The wakeup glitch filter should not be enabled if any of the external pin detect edge types is set for either edge. Enabling the wakeup glitch filter and selecting either edge detect on any pin results in unpredictable operation.

For internal module wakeup operation, the WUMEx bit enables the respective module as a wakeup source.

15.4.1 LLS mode

While in LLS, the MCU is in a state retention mode where all registers and memory retains its contents. The I/O pins are held in their input or output state. Upon wakeup, the power management control (PMC) is re-enabled, goes through a power up sequence to full regulation and releases the logic from state retention mode. The I/O states are released. Wakeup events triggered from either an external pin input or an internal module input result in a CPU interrupt flow to begin user code execution.

An LLS reset event due to RESET pin assertion causes an exit via a system reset. State retention data is lost, the I/O states return to their reset state, and the ACKISO bit is not set. The MC_SRS[WAKEUP] and MC_SRS[PIN] bits are set and the system executes a reset flow before CPU operation begins with a reset vector fetch.

15.4.2 VLLS modes

While in VLLS, much of the internal digital logic is powered down. The I/O pins are held in their input or output state. Refer to the device's Power Management chapter for powered and un-powered modules in VLLSx modes. After wakeup or reset, the PMC is re-enabled and performs a power-up sequence to full regulation.

In the case of a wakeup due to external pin or internal module wakeup, the I/O states are held until software clears the ACKISO bit (by writing a 1 to it). Recovery is always via a system reset flow and the MC_SRS[WAKEUP] is set indicating the low leakage mode was active prior to the last system reset flow.

An VLLS reset event due to RESET pin assertion causes an exit via a system reset. State retention data is lost, the I/O states return to their reset state, and the ACKISO bit is not set. The MC_SRS[WAKEUP] and MC_SRS[PIN] bits are set and the system executes a reset flow before CPU operation begins with a reset vector fetch.

15.4.3 Initialization

Flags associated with external input pins (WUFx) are cleared upon entry into LLS or VLLS modes.

For an enabled peripheral wakeup input, the peripheral flag should be cleared by the user before entering LLS or VLLS to avoid an immediate exit from LLS or VLLS.

15.4.4 Low power mode recovery

Recovery from VLLSx is through the wake-up Reset event. The chip wake-ups from VLLSx by means of reset, an enabled pin or enabled module. See the table "LLWU inputs" in the LLWU configuration section for a list of the sources.

The wake-up flow from VLLS1,2 and 3 is through reset. The wakeup bit in the SRS registers in the Mode Controller is set indicating that the chip is recovering from a low power mode. Code execution begins; however, the I/O pins are held in their pre-low-power mode entry states, and the oscillator is disabled (even if EREFSTEN had been set before entering VLLSx). Software must clear this hold by writing a 1 to the ACKISO bit in the Control and Status register in the LLWU module.

NOTE

To avoid unwanted transitions on the pins, software must re-initialize the I/O pins to their pre-low-power mode entry states *before* releasing the hold.

The oscillator cannot be re-enabled before the ACKISO bit is cleared and must be reconfigured after the hold is released.

Chapter 16

Miscellaneous Control Module (MCM)

16.1 Introduction

NOTE

For the chip-specific implementation details of this module's instances see the chip configuration chapter.

The Miscellaneous Control Module (MCM) provides a myriad of miscellaneous control functions.

16.1.1 Features

The MCM includes these distinctive features:

- Program-visible information on the platform configuration and revision
- Control and counting logic for ETB almost full

16.2 Memory Map/Register Descriptions

The memory map and register descriptions below describe the registers using byte addresses.

MCM memory map

Absolute address (hex)	Register name	Width (in bits)	Access	Reset value	Section/page
E008_0008	Crossbar switch (AXBS) slave configuration (MCM_PLASC)	16	R	001Fh	16.2.1/338

Table continues on the next page...

MCM memory map (continued)

Absolute address (hex)	Register name	Width (in bits)	Access	Reset value	Section/page
E008_000A	Crossbar switch (AXBS) master configuration (MCM_PLAMC)	16	R	003Fh	16.2.2/338
E008_000C	SRAM arbitration and protection (MCM_SRAMAP)	32	R/W	0000_0000h	16.2.3/339
E008_0010	Interrupt status register (MCM_ISR)	32	R	0000_0000h	16.2.4/340
E008_0014	ETB counter control register (MCM_ETBCC)	32	R/W	0000_0000h	16.2.5/341
E008_0018	ETB reload register (MCM_ETBRL)	32	R/W	0000_0000h	16.2.6/342
E008_001C	ETB counter value register (MCM_ETBCNT)	32	R	0000_0000h	16.2.7/343

16.2.1 Crossbar switch (AXBS) slave configuration (MCM_PLASC)

The PLASC is a 16-bit read-only register identifying the presence/absence of bus slave connections to the device's crossbar switch.

Address: MCM_PLASC is E008_0000h base + 8h offset = E008_0008h

Bit	15	14	13	12	11	10	9	8	7	6	5	4	3	2	1	0
Read	0								ASC							
Write	[Greyed out]															
Reset	0	0	0	0	0	0	0	0	0	0	0	1	1	1	1	1

MCM_PLASC field descriptions

Field	Description
15–8 Reserved	This read-only field is reserved and always has the value zero.
7–0 ASC	Each bit in the ASC field indicates if there is a corresponding connection to the crossbar switch's slave input port. 0 A bus slave connection to AXBS input port <i>n</i> is absent 1 A bus slave connection to AXBS input port <i>n</i> is present

16.2.2 Crossbar switch (AXBS) master configuration (MCM_PLAMC)

The PLAMC is a 16-bit read-only register identifying the presence/absence of bus master connections to the device's crossbar switch.

Address: MCM_PLAMC is E008_0000h base + Ah offset = E008_000Ah

Bit	15	14	13	12	11	10	9	8	7	6	5	4	3	2	1	0
Read	0								AMC							
Write	[Greyed out]															
Reset	0	0	0	0	0	0	0	0	0	0	1	1	1	1	1	1

MCM_PLAMC field descriptions

Field	Description
15–8 Reserved	This read-only field is reserved and always has the value zero.
7–0 AMC	Each bit in the AMC field indicates if there is a corresponding connection to the AXBS master input port. 0 A bus master connection to AXBS input port <i>n</i> is absent 1 A bus master connection to AXBS input port <i>n</i> is present

16.2.3 SRAM arbitration and protection (MCM_SRAMAP)

The SRAMAP register defines the arbitration and protection schemes for the two SRAM arrays.

NOTE

Bits 23-0 are undefined after reset.

Address: MCM_SRAMAP is E008_0000h base + Ch offset = E008_000Ch

Bit	31	30	29	28	27	26	25	24	23	22	21	20	19	18	17	16
R	0	SRAMLWP	SRAMLAP		0	SRAMUWP	SRAMUAP		Reserved							
W																
Reset	0	0	0	0	0	0	0	0	0	0	0	0	0	0	0	0
Bit	15	14	13	12	11	10	9	8	7	6	5	4	3	2	1	0
R	Reserved								Reserved							
W																
Reset	0	0	0	0	0	0	0	0	0	0	0	0	0	0	0	0

MCM_SRAMAP field descriptions

Field	Description
31 Reserved	This read-only field is reserved and always has the value zero.
30 SRAMLWP	SRAM_L write protect When this bit is set, writes to SRAM_L array generates a bus error.
29–28 SRAMLAP	SRAM_L arbitration priority Defines the arbitration scheme and priority for the processor and SRAM backdoor accesses to the SRAM_L array. 00 Round robin

Table continues on the next page...

MCM_SRAMAP field descriptions (continued)

Field	Description
	01 Special round robin (favors SRAM backdoor accesses over the processor) 10 Fixed priority. Processor has highest, backdoor has lowest 11 Fixed priority. Backdoor has highest, processor has lowest
27 Reserved	This read-only field is reserved and always has the value zero.
26 SRAMUWP	SRAM_U write protect When this bit is set, writes to SRAM_U array generates a bus error.
25–24 SRAMUAP	SRAM_U arbitration priority Defines the arbitration scheme and priority for the processor and SRAM backdoor accesses to the SRAM_U array. 00 Round robin 01 Special round robin (favors SRAM backdoor accesses over the processor) 10 Fixed priority. Processor has highest, backdoor has lowest 11 Fixed priority. Backdoor has highest, processor has lowest
23–9 Reserved	This field is reserved.
8–0 Reserved	This field is reserved.

16.2.4 Interrupt status register (MCM_ISR)

Address: MCM_ISR is E008_0000h base + 10h offset = E008_0010h

Bit	31	30	29	28	27	26	25	24	23	22	21	20	19	18	17	16
R	0															
W	[Shaded]															
Reset	0	0	0	0	0	0	0	0	0	0	0	0	0	0	0	0
Bit	15	14	13	12	11	10	9	8	7	6	5	4	3	2	1	0
R	0											0	NMI	IRQ	0	
W	[Shaded]											[Shaded]	w1c	w1c	[Shaded]	
Reset	0	0	0	0	0	0	0	0	0	0	0	0	0	0	0	0

MCM_ISR field descriptions

Field	Description
31–4 Reserved	This read-only field is reserved and always has the value zero.
3 Reserved	This read-only field is reserved and always has the value zero.

Table continues on the next page...

MCM_ISR field descriptions (continued)

Field	Description
2 NMI	<p>Non-maskable interrupt pending</p> <p>If ETBCC[RSPT] is set to 10b, this bit is set when the ETB counter expires.</p> <p>0 No pending NMI 1 Due to the ETB counter expiring, an NMI is pending</p>
1 IRQ	<p>Normal interrupt pending</p> <p>If ETBCC[RSPT] is set to 01b, this bit is set when the ETB counter expires.</p> <p>0 No pending interrupt 1 Due to the ETB counter expiring, a normal interrupt is pending</p>
0 Reserved	This read-only field is reserved and always has the value zero.

16.2.5 ETB counter control register (MCM_ETBCC)

Address: MCM_ETBCC is E008_0000h base + 14h offset = E008_0014h

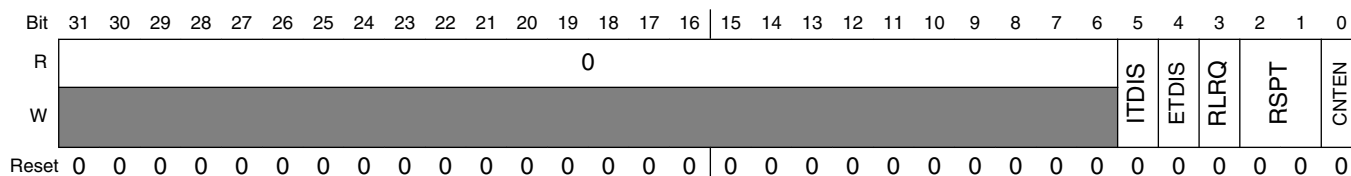

MCM_ETBCC field descriptions

Field	Description
31–6 Reserved	This read-only field is reserved and always has the value zero.
5 ITDIS	<p>ITM-to-TPIU disable</p> <p>Disables the trace path from ITM to TPIU</p> <p>0 ITM-to-TPIU trace path enabled 1 ITM-to-TPIU trace path disabled</p>
4 ETDIS	<p>ETM-to-TPIU disable</p> <p>Disables the trace path from ETM to TPIU</p> <p>0 ETM-to-TPIU trace path enabled 1 ETM-to-TPIU trace path disabled</p>
3 RLRQ	<p>Reload request</p> <p>Reloads the ETB packet counter with the MCM_ETBRL RELOAD value.</p> <p>If IRQ or NMI interrupts were enabled and an NMI or IRQ interrupt was generated on counter expiration, setting this bit clears the pending NMI or IRQ interrupt request.</p>

Table continues on the next page...

MCM_ETBCC field descriptions (continued)

Field	Description
	<p>If debug halt was enabled and a debug halt request was asserted on counter expiration, setting this bit clears the debug halt request.</p> <p>0 No effect 1 Clears pending debug halt, NMI, or IRQ interrupt requests</p>
2–1 RSPT	<p>Response type</p> <p>00 No response when the ETB count expires 01 Generate a normal interrupt when the ETB count expires 10 Generate an NMI when the ETB count expires 11 Generate a debug halt when the ETB count expires</p>
0 CNTEN	<p>Counter enable</p> <p>Enables the ETB counter.</p> <p>0 ETB counter disabled 1 ETB counter enabled</p>

16.2.6 ETB reload register (MCM_ETBRL)

Address: MCM_ETBRL is E008_0000h base + 18h offset = E008_0018h

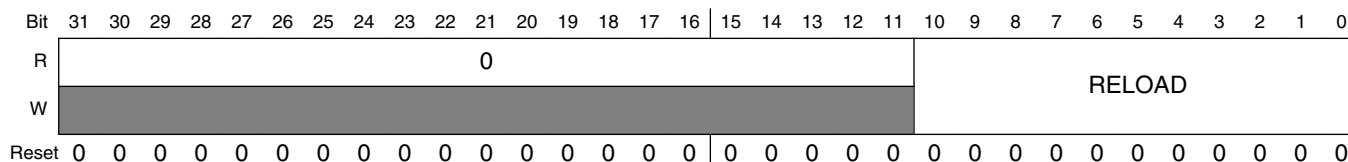

MCM_ETBRL field descriptions

Field	Description
31–11 Reserved	This read-only field is reserved and always has the value zero.
10–0 RELOAD	<p>Byte count reload value</p> <p>Indicates the 0-mod-4 value the counter reloads to. Writing a non-0-mod-4 value to this field results in an bus error</p>

16.2.7 ETB counter value register (MCM_ETBCNT)

Address: MCM_ETBCNT is E008_0000h base + 1Ch offset = E008_001Ch

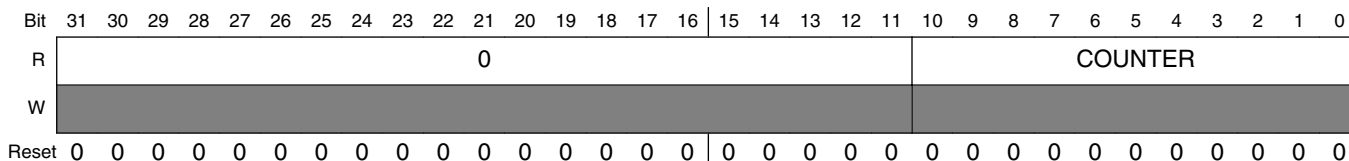

MCM_ETBCNT field descriptions

Field	Description
31–11 Reserved	This read-only field is reserved and always has the value zero.
10–0 COUNTER	Byte count counter value Indicates the current 0-mod-4 value of the counter.

16.3 Functional Description

This section describes the functional description of MCM module.

16.3.1 Interrupts

The MCM generates two interrupt requests:

- Non-maskable interrupt
- Normal interrupt

16.3.1.1 Non-maskable interrupt

The MCM's non-maskable interrupt (NMI) is generated, if:

- MCM_ISCR[ETBN] is set, which is caused by
 - The ETB counter is enabled (MCM_ETBCC[CNTEN] = 1),
 - The ETB count expires, and
 - The response to counter expiration is an NMI (MCM_ETBCC[RSPT] = 10)

16.3.1.2 Normal interrupt

The MCM's normal interrupt is generated if any of the following are true:

- MCM_ISCR[ETBI] is set, which is caused by
 - The ETB counter is enabled (MCM_ETBCC[CENTEN] = 1),
 - The ETB count expires, and
 - The response to counter expiration is a normal interrupt (MCM_ETBCC[RSPT] = 01)

Chapter 17

Crossbar Switch (AXBS)

17.1 Introduction

NOTE

For the chip-specific implementation details of this module's instances see the chip configuration chapter.

This chapter provides information on the layout, configuration, and programming of the crossbar switch. The crossbar switch connects bus masters and bus slaves using a crossbar switch structure. This structure allows all bus masters to access different bus slaves simultaneously, while providing arbitration among the bus masters when they access the same slave. A variety of bus arbitration methods and attributes may be programmed on a slave by slave basis.

17.1.1 Features

The crossbar switch includes these distinctive features:

- Symmetric crossbar bus switch implementation
 - Allows concurrent accesses from different masters to different slaves
 - Slave arbitration attributes configured on a slave by slave basis
- 32-bit width and support for byte, 2-byte, 4-byte, and 16-byte burst transfers
- Operation at a 1-to-1 clock frequency with the bus masters
- Low-Power Park mode support

17.2 Memory Map / Register Definition

Each slave port of the crossbar switch contains configuration registers. Read- and write-transfers require two bus clock cycles. The registers can be read from and written to only in supervisor mode. Additionally, these registers can be read from or written to only by 32-bit accesses.

A bus error response is returned if an unimplemented location is accessed within the crossbar switch.

The slave registers also feature a bit that, when set, prevents the registers from being written. The registers remain readable, but future write attempts have no effect on the registers and are terminated with a bus error response to the master initiating the write. The core, for example, takes a bus error interrupt.

NOTE

This section shows the registers for all eight master and slave ports. If a master or slave is not used on this particular device, then unexpected results occur when writing to its registers. See the chip configuration details for the exact master/slave assignments for your device.

AXBS memory map

Absolute address (hex)	Register name	Width (in bits)	Access	Reset value	Section/page
4000_4000	Priority Registers Slave (AXBS_PRS0)	32	R/W	7654_3210h	17.2.1/347
4000_4010	Control Register (AXBS_CRS0)	32	R/W	0000_0000h	17.2.2/350
4000_4100	Priority Registers Slave (AXBS_PRS1)	32	R/W	7654_3210h	17.2.1/347
4000_4110	Control Register (AXBS_CRS1)	32	R/W	0000_0000h	17.2.2/350
4000_4200	Priority Registers Slave (AXBS_PRS2)	32	R/W	7654_3210h	17.2.1/347
4000_4210	Control Register (AXBS_CRS2)	32	R/W	0000_0000h	17.2.2/350
4000_4300	Priority Registers Slave (AXBS_PRS3)	32	R/W	7654_3210h	17.2.1/347
4000_4310	Control Register (AXBS_CRS3)	32	R/W	0000_0000h	17.2.2/350
4000_4400	Priority Registers Slave (AXBS_PRS4)	32	R/W	7654_3210h	17.2.1/347
4000_4410	Control Register (AXBS_CRS4)	32	R/W	0000_0000h	17.2.2/350
4000_4500	Priority Registers Slave (AXBS_PRS5)	32	R/W	7654_3210h	17.2.1/347
4000_4510	Control Register (AXBS_CRS5)	32	R/W	0000_0000h	17.2.2/350

Table continues on the next page...

AXBS memory map (continued)

Absolute address (hex)	Register name	Width (in bits)	Access	Reset value	Section/page
4000_4600	Priority Registers Slave (AXBS_PRS6)	32	R/W	7654_3210h	17.2.1/347
4000_4610	Control Register (AXBS_CRS6)	32	R/W	0000_0000h	17.2.2/350
4000_4700	Priority Registers Slave (AXBS_PRS7)	32	R/W	7654_3210h	17.2.1/347
4000_4710	Control Register (AXBS_CRS7)	32	R/W	0000_0000h	17.2.2/350
4000_4800	Master General Purpose Control Register (AXBS_MGPCR0)	32	R/W	0000_0000h	17.2.3/352
4000_4900	Master General Purpose Control Register (AXBS_MGPCR1)	32	R/W	0000_0000h	17.2.3/352
4000_4A00	Master General Purpose Control Register (AXBS_MGPCR2)	32	R/W	0000_0000h	17.2.3/352
4000_4B00	Master General Purpose Control Register (AXBS_MGPCR3)	32	R/W	0000_0000h	17.2.3/352
4000_4C00	Master General Purpose Control Register (AXBS_MGPCR4)	32	R/W	0000_0000h	17.2.3/352
4000_4D00	Master General Purpose Control Register (AXBS_MGPCR5)	32	R/W	0000_0000h	17.2.3/352
4000_4E00	Master General Purpose Control Register (AXBS_MGPCR6)	32	R/W	0000_0000h	17.2.3/352
4000_4F00	Master General Purpose Control Register (AXBS_MGPCR7)	32	R/W	0000_0000h	17.2.3/352

17.2.1 Priority Registers Slave (AXBS_PRS_n)

The priority registers (PRSn) set the priority of each master port on a per slave port basis and reside in each slave port. The priority register can be accessed only with 32-bit accesses. After the CRS_n[RO] bit is set, the PRSn register can only be read; attempts to write to it have no effect on PRSn and result in a bus-error response to the master initiating the write.

No two available master ports may be programmed with the same priority level. Attempts to program two or more masters with the same priority level result in a bus-error response and the PRSn is not updated.

NOTE

The possible values for the PRSn fields depend on the number of masters available on the device. See the device's Chip Configuration details for the number of masters supported.

- If the device contains less than five masters, values 000–011 are valid and writing other values results in an error.
- If the device contains n masters where $n \geq 5$, values 0 to $n-1$ are valid and writing other values results in an error.

Addresses: AXBS_PRS0 is 4000_4000h base + 0h offset = 4000_4000h
 AXBS_PRS1 is 4000_4000h base + 100h offset = 4000_4100h
 AXBS_PRS2 is 4000_4000h base + 200h offset = 4000_4200h
 AXBS_PRS3 is 4000_4000h base + 300h offset = 4000_4300h
 AXBS_PRS4 is 4000_4000h base + 400h offset = 4000_4400h
 AXBS_PRS5 is 4000_4000h base + 500h offset = 4000_4500h
 AXBS_PRS6 is 4000_4000h base + 600h offset = 4000_4600h
 AXBS_PRS7 is 4000_4000h base + 700h offset = 4000_4700h

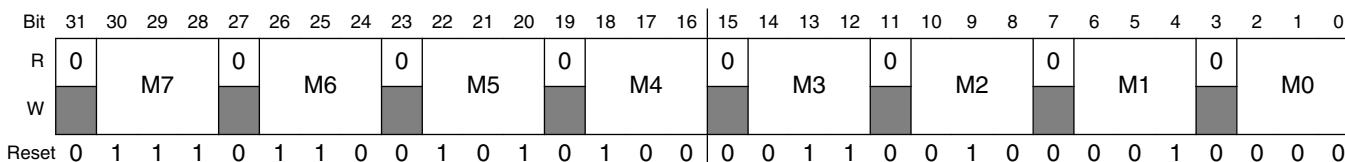

AXBS_PRSn field descriptions

Field	Description
31 Reserved	This read-only field is reserved and always has the value zero.
30–28 M7	Master 7 priority. Sets the arbitration priority for this port on the associated slave port. 000 This master has level 1, or highest, priority when accessing the slave port. 001 This master has level 2 priority when accessing the slave port. 010 This master has level 3 priority when accessing the slave port. 011 This master has level 4 priority when accessing the slave port. 100 This master has level 5 priority when accessing the slave port. 101 This master has level 6 priority when accessing the slave port. 110 This master has level 7 priority when accessing the slave port. 111 This master has level 8, or lowest, priority when accessing the slave port.
27 Reserved	This read-only field is reserved and always has the value zero.
26–24 M6	Master 6 priority. Sets the arbitration priority for this port on the associated slave port. 000 This master has level 1, or highest, priority when accessing the slave port. 001 This master has level 2 priority when accessing the slave port. 010 This master has level 3 priority when accessing the slave port. 011 This master has level 4 priority when accessing the slave port. 100 This master has level 5 priority when accessing the slave port. 101 This master has level 6 priority when accessing the slave port. 110 This master has level 7 priority when accessing the slave port. 111 This master has level 8, or lowest, priority when accessing the slave port.
23 Reserved	This read-only field is reserved and always has the value zero.

Table continues on the next page...

AXBS_PRSn field descriptions (continued)

Field	Description
22–20 M5	Master 5 priority. Sets the arbitration priority for this port on the associated slave port. 000 This master has level 1, or highest, priority when accessing the slave port. 001 This master has level 2 priority when accessing the slave port. 010 This master has level 3 priority when accessing the slave port. 011 This master has level 4 priority when accessing the slave port. 100 This master has level 5 priority when accessing the slave port. 101 This master has level 6 priority when accessing the slave port. 110 This master has level 7 priority when accessing the slave port. 111 This master has level 8, or lowest, priority when accessing the slave port.
19 Reserved	This read-only field is reserved and always has the value zero.
18–16 M4	Master 4 priority. Sets the arbitration priority for this port on the associated slave port. 000 This master has level 1, or highest, priority when accessing the slave port. 001 This master has level 2 priority when accessing the slave port. 010 This master has level 3 priority when accessing the slave port. 011 This master has level 4 priority when accessing the slave port. 100 This master has level 5 priority when accessing the slave port. 101 This master has level 6 priority when accessing the slave port. 110 This master has level 7 priority when accessing the slave port. 111 This master has level 8, or lowest, priority when accessing the slave port.
15 Reserved	This read-only field is reserved and always has the value zero.
14–12 M3	Master 3 priority. Sets the arbitration priority for this port on the associated slave port. 000 This master has level 1, or highest, priority when accessing the slave port. 001 This master has level 2 priority when accessing the slave port. 010 This master has level 3 priority when accessing the slave port. 011 This master has level 4 priority when accessing the slave port. 100 This master has level 5 priority when accessing the slave port. 101 This master has level 6 priority when accessing the slave port. 110 This master has level 7 priority when accessing the slave port. 111 This master has level 8, or lowest, priority when accessing the slave port.
11 Reserved	This read-only field is reserved and always has the value zero.
10–8 M2	Master 2 priority. Sets the arbitration priority for this port on the associated slave port. 000 This master has level 1, or highest, priority when accessing the slave port. 001 This master has level 2 priority when accessing the slave port. 010 This master has level 3 priority when accessing the slave port. 011 This master has level 4 priority when accessing the slave port. 100 This master has level 5 priority when accessing the slave port. 101 This master has level 6 priority when accessing the slave port. 110 This master has level 7 priority when accessing the slave port. 111 This master has level 8, or lowest, priority when accessing the slave port.

Table continues on the next page...

AXBS_PRSn field descriptions (continued)

Field	Description
7 Reserved	This read-only field is reserved and always has the value zero.
6-4 M1	<p>Master 1 priority. Sets the arbitration priority for this port on the associated slave port.</p> <p>000 This master has level 1, or highest, priority when accessing the slave port. 001 This master has level 2 priority when accessing the slave port. 010 This master has level 3 priority when accessing the slave port. 011 This master has level 4 priority when accessing the slave port. 100 This master has level 5 priority when accessing the slave port. 101 This master has level 6 priority when accessing the slave port. 110 This master has level 7 priority when accessing the slave port. 111 This master has level 8, or lowest, priority when accessing the slave port.</p>
3 Reserved	This read-only field is reserved and always has the value zero.
2-0 M0	<p>Master 0 priority. Sets the arbitration priority for this port on the associated slave port.</p> <p>000 This master has level 1, or highest, priority when accessing the slave port. 001 This master has level 2 priority when accessing the slave port. 010 This master has level 3 priority when accessing the slave port. 011 This master has level 4 priority when accessing the slave port. 100 This master has level 5 priority when accessing the slave port. 101 This master has level 6 priority when accessing the slave port. 110 This master has level 7 priority when accessing the slave port. 111 This master has level 8, or lowest, priority when accessing the slave port.</p>

17.2.2 Control Register (AXBS_CRSn)

These registers control several features of each slave port and must be accessed using 32-bit accesses. After CRSn[RO] is set, the CRSn can only be read; attempts to write to it have no effect and result in an error response.

Addresses: AXBS_CRSn is 4000_4000h base + 10h offset = 4000_4010h

AXBS_CRSn is 4000_4000h base + 110h offset = 4000_4110h

AXBS_CRSn is 4000_4000h base + 210h offset = 4000_4210h

AXBS_CRSn is 4000_4000h base + 310h offset = 4000_4310h

AXBS_CRSn is 4000_4000h base + 410h offset = 4000_4410h

AXBS_CRSn is 4000_4000h base + 510h offset = 4000_4510h

AXBS_CRSn is 4000_4000h base + 610h offset = 4000_4610h

AXBS_CRSn is 4000_4000h base + 710h offset = 4000_4710h

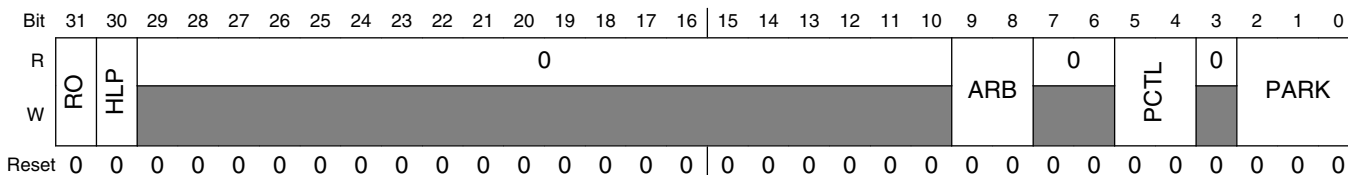

AXBS_CRSn field descriptions

Field	Description
31 RO	<p>Read only</p> <p>Forces the slave port's CSRn and PRSn registers to be read-only. After set, only a hardware reset clears it.</p> <p>0 The slave port's registers are writeable 1 The slave port's registers are read-only and cannot be written. Attempted writes have no effect on the registers and result in a bus error response.</p>
30 HLP	<p>Halt low priority</p> <p>Sets the initial arbitration priority for low power mode requests. Setting this bit will not effect the request for low power mode from attaining highest priority once it has control of the slave ports.</p> <p>0 The low power mode request has the highest priority for arbitration on this slave port 1 The low power mode request has the lowest initial priority for arbitration on this slave port</p>
29–10 Reserved	<p>This read-only field is reserved and always has the value zero.</p>
9–8 ARB	<p>Arbitration mode</p> <p>Selects the arbitration policy for the slave port.</p> <p>00 Fixed priority 01 Round-robin, or rotating, priority 10 Reserved 11 Reserved</p>
7–6 Reserved	<p>This read-only field is reserved and always has the value zero.</p>
5–4 PCTL	<p>Parking control</p> <p>Determines the slave port's parking control. The low-power park feature results in an overall power savings if the slave port is not saturated. However, this forces an extra latency clock when any master tries to access the slave port while not in use because it is not parked on any master.</p> <p>00 When no master makes a request, the arbiter parks the slave port on the master port defined by the PARK bit field 01 When no master makes a request, the arbiter parks the slave port on the last master to be in control of the slave port 10 When no master makes a request, the slave port is not parked on a master and the arbiter drives all outputs to a constant safe state 11 Reserved</p>
3 Reserved	<p>This read-only field is reserved and always has the value zero.</p>
2–0 PARK	<p>Park</p> <p>Determines which master port the current slave port parks on when no masters are actively making requests and the PCTL bits are cleared.</p> <p>NOTE: Only select master ports that are actually present on the device. If not, undefined behavior may occur.</p> <p>000 Park on master port M0</p>

Table continues on the next page...

AXBS_CRSn field descriptions (continued)

Field	Description
001	Park on master port M1
010	Park on master port M2
011	Park on master port M3
100	Park on master port M4
101	Park on master port M5
110	Reserved
111	Reserved

17.2.3 Master General Purpose Control Register (AXBS_MGPCRn)

The MGPCR controls only whether the master’s undefined length burst accesses are allowed to complete uninterrupted or whether they can be broken by requests from higher priority masters. The MGPCR can only be accessed in Supervisor mode with 32-bit accesses.

Addresses: AXBS_MGPCR0 is 4000_4000h base + 800h offset = 4000_4800h

AXBS_MGPCR1 is 4000_4000h base + 900h offset = 4000_4900h

AXBS_MGPCR2 is 4000_4000h base + A00h offset = 4000_4A00h

AXBS_MGPCR3 is 4000_4000h base + B00h offset = 4000_4B00h

AXBS_MGPCR4 is 4000_4000h base + C00h offset = 4000_4C00h

AXBS_MGPCR5 is 4000_4000h base + D00h offset = 4000_4D00h

AXBS_MGPCR6 is 4000_4000h base + E00h offset = 4000_4E00h

AXBS_MGPCR7 is 4000_4000h base + F00h offset = 4000_4F00h

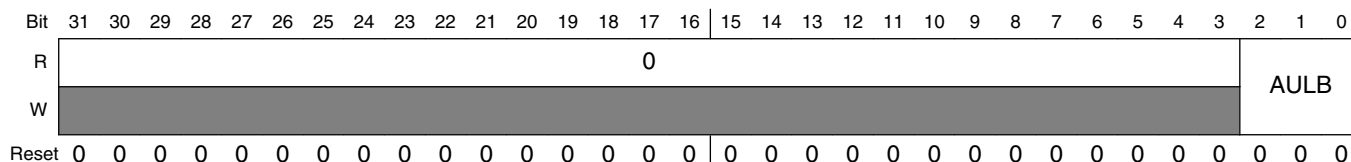

AXBS_MGPCRn field descriptions

Field	Description
31–3 Reserved	This read-only field is reserved and always has the value zero.
2–0 AULB	<p>Arbitrates on undefined length bursts</p> <p>Determines whether, and when, the crossbar switch arbitrates away the slave port the master owns when the master is performing undefined length burst accesses.</p> <p>000 No arbitration is allowed during an undefined length burst</p> <p>001 Arbitration is allowed at any time during an undefined length burst</p> <p>010 Arbitration is allowed after four beats of an undefined length burst</p> <p>011 Arbitration is allowed after eight beats of an undefined length burst</p> <p>100 Arbitration is allowed after 16 beats of an undefined length burst</p>

Table continues on the next page...

AXBS_MGPCR_n field descriptions (continued)

Field	Description
101	Reserved
110	Reserved
111	Reserved

17.3 Functional Description

17.3.1 General operation

When a master accesses the crossbar switch the access is immediately taken. If the targeted slave port of the access is available, then the access is immediately presented on the slave port. It is possible to make single-clock, or zero wait state, accesses through the crossbar. If the targeted slave port of the access is busy or parked on a different master port, the requesting master simply sees wait states inserted until the targeted slave port can service the master's request. The latency in servicing the request depends on each master's priority level and the responding peripheral's access time.

Because the crossbar switch appears to be just another slave to the master device, the master device has no knowledge of whether it actually owns the slave port it is targeting. While the master does not have control of the slave port it is targeting, it simply waits.

A master is given control of the targeted slave port only after a previous access to a different slave port completes, regardless of its priority on the newly targeted slave port. This prevents deadlock from occurring when:

- A higher priority master has:
 - An outstanding request to one slave port that has a long response time and
 - A pending access to a different slave port, and
- A lower priority master is also making a request to the same slave port as the pending access of the higher priority master.

After the master has control of the slave port it is targeting, the master remains in control of that slave port until it gives up the slave port by running an IDLE cycle or by leaving that slave port for its next access.

The master could also lose control of the slave port if another higher priority master makes a request to the slave port; however, if the master is running a fixed-length burst transfer it retains control of the slave port until that transfer completes. Based on MGPCR[AULB], the master either retains control of the slave port when doing undefined length incrementing burst transfers or loses the bus to a higher priority master.

The crossbar terminates all master IDLE transfers, as opposed to allowing the termination to come from one of the slave busses. Additionally, when no master is requesting access to a slave port, the crossbar drives IDLE transfers onto the slave bus, even though a default master may be granted access to the slave port.

When a slave bus is being idled by the crossbar, it can park the slave port on the master port indicated by $CRS_n[PARK]$. This is done to save the initial clock of arbitration delay that otherwise would be seen if the master had to arbitrate to gain control of the slave port. The slave port can also be put into Low Power Park mode to save power, by using $CRS_n[PCTL]$.

17.3.2 Register coherency

Because the content of the registers has a real-time effect on the operation of the crossbar, it is important to understand that any register modifications take effect as soon as the register is written. The values of the registers do not track with slave-port-related master accesses, but instead track only with slave accesses.

The $MGPCR_x[AULB]$ bits are the exception to this rule. The update of these bits is only recognized when the master on that master port runs an IDLE cycle, even though the slave bus cycle to write them will have already terminated successfully. If the $MGPCR_x[AULB]$ bits are written between two burst accesses, the new AULB encodings do not take effect until an IDLE cycle is initiated by the master on that master port.

17.3.3 Arbitration

The crossbar switch supports two arbitration schemes:

- A fixed-priority comparison algorithm
- A round-robin fairness algorithm

The arbitration scheme is independently programmable for each slave port.

17.3.3.1 Arbitration during undefined length bursts

Arbitration points during an undefined length burst are defined by the current master's $MGPCR[AULB]$ field setting. When a defined length is imposed on the burst via the AULB bits, the undefined length burst is treated as a single or series of single back-to-back fixed-length burst accesses.

The following figure illustrates an example:

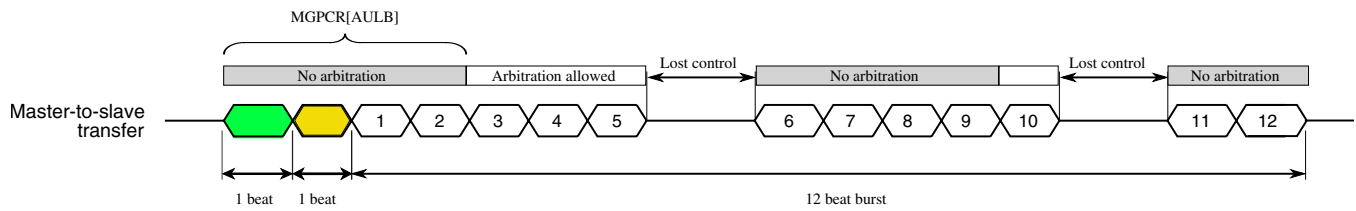

Figure 17-28. Undefined length burst example

In this example, a master runs an undefined length burst and the MGPCCR[AULB] bits indicate arbitration occurs after the fourth beat of the burst. The master runs two sequential beats and then starts what will be a 12-beat undefined length burst access to a new address within the same slave port region as the previous access. The crossbar does not allow an arbitration point until the fourth overall access, or the second beat of the second burst. At that point, all remaining accesses are open for arbitration until the master loses control of the slave port.

Assume the master loses control of the slave port after the fifth beat of the second burst. After the master regains control of the slave port no arbitration point is available until after the master has run four more beats of its burst. After the fourth beat of the now continued burst, or the ninth beat of the second burst from the master's perspective, is taken, all beats of the burst are once again open for arbitration until the master loses control of the slave port.

Assume the master again loses control of the slave port on the fifth beat of the third now continued burst, or the 10th beat of the second burst from the master's perspective. After the master regains control of the slave port, it is allowed to complete its final two beats of its burst without facing arbitration.

Note

Fixed-length burst accesses are not affected by the AULB bits. All fixed-length burst accesses lock out arbitration until the last beat of the fixed-length burst.

17.3.3.2 Fixed-priority operation

When operating in Fixed-Priority mode, each master is assigned a unique priority level in the priority registers (PRSn) . If two masters request access to a slave port, the master with the highest priority in the selected priority register gains control over the slave port.

Functional Description

When a master makes a request to a slave port, the slave port checks if the new requesting master's priority level is higher than that of the master that currently has control over the slave port, unless the slave port is in a parked state. The slave port performs an arbitration check at every clock edge to ensure that the proper master, if any, has control of the slave port.

The following table describes possible scenarios based on the requesting master port:

Table 17-29. How AXBS grants control of a slave port to a master

When	Then AXBS grants control to the requesting master
Both of the following are true: <ul style="list-style-type: none"> The current master is not running a transfer. The new requesting master's priority level is higher than that of the current master. 	At the next clock edge
Both of the following are true: <ul style="list-style-type: none"> The current master is running a fixed length burst transfer or a locked transfer. The requesting master's priority level is higher than that of the current master. 	At the end of the burst transfer or locked transfer
The master is running an undefined length burst transfer.	At the next arbitration point NOTE: Arbitration points for an undefined length burst are defined in the MGPCR for each master.
The requesting master's priority level is lower than the current master.	At the conclusion of one of the following cycles: <ul style="list-style-type: none"> An IDLE cycle A non-IDLE cycle to a location other than the current slave port

17.3.3.3 Round-robin priority operation

When operating in Round-Robin mode, each master is assigned a relative priority based on the master port number. This relative priority is compared to the master port number (ID) of the last master to perform a transfer on the slave bus. The highest priority requesting master becomes owner of the slave bus at the next transfer boundary, accounting for locked and fixed-length burst transfers. Priority is based on how far ahead the ID of the requesting master is to the ID of the last master.

After granted access to a slave port, a master may perform as many transfers as desired to that port until another master makes a request to the same slave port. The next master in line is granted access to the slave port at the next transfer boundary, or possibly on the next clock cycle if the current master has no pending access request.

As an example of arbitration in Round-Robin mode, assume the crossbar is implemented with master ports 0, 1, 4, and 5. If the last master of the slave port was master 1, and master 0, 4 and 5 make simultaneous requests, they are serviced in the order 4, 5, and then 0.

Parking may continue to be used in a round-robin mode, but does not affect the round-robin pointer unless the parked master actually performs a transfer. Handoff occurs to the next master in line after one cycle of arbitration. If the slave port is put into low-power park mode, the round-robin pointer is reset to point at master port 0, giving it the highest priority.

17.3.3.4 Priority assignment

Each master port needs to be assigned a unique 3-bit priority level. If an attempt is made to program multiple master ports with the same priority level within the priority registers (PRSn), the crossbar switch responds with a bus error and the registers are not updated.

17.4 Initialization/application information

No initialization is required by or for the crossbar switch. Hardware reset ensures all the register bits used by the crossbar switch are properly initialized to a valid state. Settings and priorities should be programmed to achieve maximum system performance.

Chapter 18

Memory Protection Unit (MPU)

18.1 Introduction

NOTE

For the chip-specific implementation details of this module's instances see the chip configuration chapter.

The Memory Protection Unit (MPU) provides hardware access control for all memory references generated in the device.

18.2 Overview

The MPU concurrently monitors all system bus transactions and evaluates their appropriateness using pre-programmed region descriptors that define memory spaces and their access rights. Memory references that have sufficient access control rights are allowed to complete, while references that are not mapped to any region descriptor or have insufficient rights are terminated with a protection error response.

18.2.1 Block Diagram

A simplified block diagram of the MPU module is shown in the following figure. The hardware's two-dimensional connection matrix is clearly visible with the basic access evaluation macro shown as the replicated submodule block. The crossbar switch slave ports are shown on the left, the region descriptor registers in the middle, and the peripheral bus interface on the right side. The evaluation macro contains two magnitude comparators connected to the start and end address registers from each region descriptor as well as the combinational logic blocks to determine the region hit and the access protection error. For details of the access evaluation macro, see [Access Evaluation Macro](#).

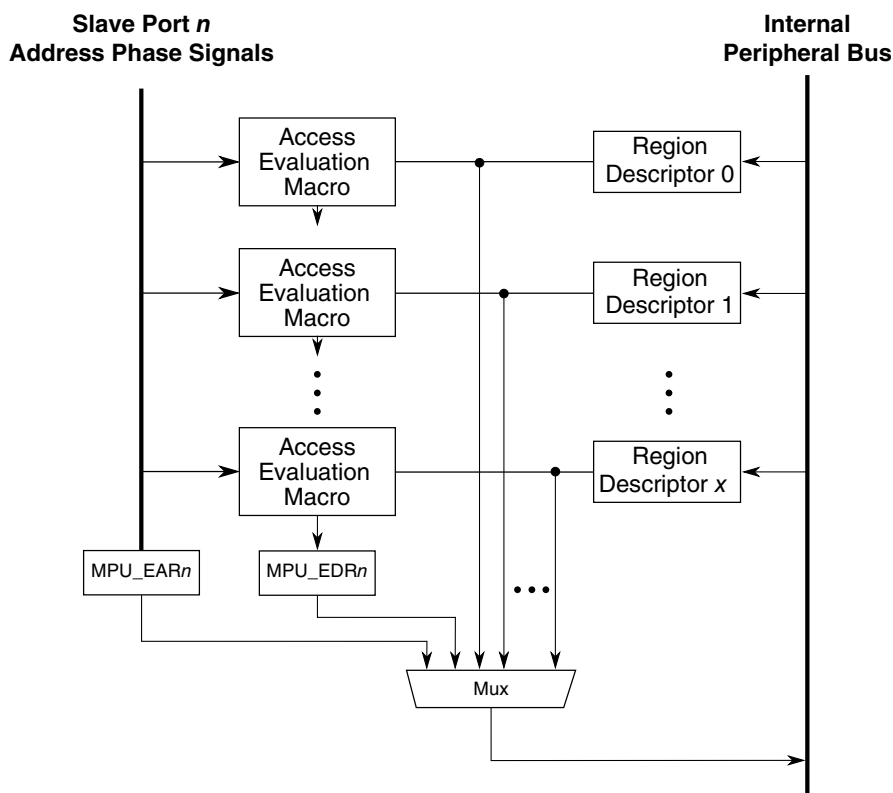

Figure 18-1. MPU Block Diagram

18.2.2 Features

The MPU implements a two-dimensional hardware array of memory region descriptors and the crossbar slave ports to continuously monitor the legality of every memory reference generated by each bus master in the system. The feature set includes:

- 12 program-visible 128-bit region descriptors, accessible by four 32-bit words each
 - Each region descriptor defines a modulo-32 byte space, aligned anywhere in memory
 - Region sizes can vary from 32 bytes to 4 Gbytes
 - Two access control permissions defined in a single descriptor word
 - Masters 0–3: read, write, and execute attributes for supervisor and user accesses
 - Masters 4–7: read and write attributes
- Hardware-assisted maintenance of the descriptor valid bit minimizes coherency issues

- Alternate programming model view of the access control permissions word
- Priority given to granting permission over denying access for overlapping region descriptors
- Detects access protection errors if a memory reference does not hit in any memory region, or if the reference is illegal in all hit memory regions. If an access error occurs, the reference is terminated with an error response, and the MPU inhibits the bus cycle being sent to the targeted slave device.
- Error registers (per slave port) capture the last faulting address, attributes, and other information
- Global MPU enable/disable control bit

18.3 Memory Map/Register Definition

The programming model is partitioned into three groups: control/status registers, the data structure containing the region descriptors, and the alternate view of the region descriptor access control values.

The programming model can only be referenced using 32-bit accesses. Attempted references using different access sizes, to undefined (reserved) addresses, or with a non-supported access type (a write to a read-only register, or a read of a write-only register) generate an error termination.

The programming model can be accessed only in supervisor mode.

NOTE

See the chip configuration details for any chip-specific register information for this module.

MPU memory map

Absolute address (hex)	Register name	Width (in bits)	Access	Reset value	Section/page
4000_D000	Control/Error Status Register (MPU_CESR)	32	R/W	0081_5101h	18.3.1/364
4000_D010	Error Address Register, Slave Port n (MPU_EAR0)	32	R	Undefined	18.3.2/366
4000_D014	Error Detail Register, Slave Port n (MPU_EDR0)	32	R	Undefined	18.3.3/367
4000_D018	Error Address Register, Slave Port n (MPU_EAR1)	32	R	Undefined	18.3.2/366
4000_D01C	Error Detail Register, Slave Port n (MPU_EDR1)	32	R	Undefined	18.3.3/367

Table continues on the next page...

MPU memory map (continued)

Absolute address (hex)	Register name	Width (in bits)	Access	Reset value	Section/page
4000_D020	Error Address Register, Slave Port n (MPU_EAR2)	32	R	Undefined	18.3.2/366
4000_D024	Error Detail Register, Slave Port n (MPU_EDR2)	32	R	Undefined	18.3.3/367
4000_D028	Error Address Register, Slave Port n (MPU_EAR3)	32	R	Undefined	18.3.2/366
4000_D02C	Error Detail Register, Slave Port n (MPU_EDR3)	32	R	Undefined	18.3.3/367
4000_D030	Error Address Register, Slave Port n (MPU_EAR4)	32	R	Undefined	18.3.2/366
4000_D034	Error Detail Register, Slave Port n (MPU_EDR4)	32	R	Undefined	18.3.3/367
4000_D400	Region Descriptor n, Word 0 (MPU_RGD0_WORD0)	32	R/W	0000_0000h	18.3.4/368
4000_D404	Region Descriptor n, Word 1 (MPU_RGD0_WORD1)	32	R/W	0000_001Fh	18.3.5/369
4000_D408	Region Descriptor n, Word 2 (MPU_RGD0_WORD2)	32	R/W	0000_0000h	18.3.6/369
4000_D40C	Region Descriptor n, Word 3 (MPU_RGD0_WORD3)	32	R/W	0000_0000h	18.3.7/372
4000_D410	Region Descriptor n, Word 0 (MPU_RGD1_WORD0)	32	R/W	0000_0000h	18.3.4/368
4000_D414	Region Descriptor n, Word 1 (MPU_RGD1_WORD1)	32	R/W	0000_001Fh	18.3.5/369
4000_D418	Region Descriptor n, Word 2 (MPU_RGD1_WORD2)	32	R/W	0000_0000h	18.3.6/369
4000_D41C	Region Descriptor n, Word 3 (MPU_RGD1_WORD3)	32	R/W	0000_0000h	18.3.7/372
4000_D420	Region Descriptor n, Word 0 (MPU_RGD2_WORD0)	32	R/W	0000_0000h	18.3.4/368
4000_D424	Region Descriptor n, Word 1 (MPU_RGD2_WORD1)	32	R/W	0000_001Fh	18.3.5/369
4000_D428	Region Descriptor n, Word 2 (MPU_RGD2_WORD2)	32	R/W	0000_0000h	18.3.6/369
4000_D42C	Region Descriptor n, Word 3 (MPU_RGD2_WORD3)	32	R/W	0000_0000h	18.3.7/372
4000_D430	Region Descriptor n, Word 0 (MPU_RGD3_WORD0)	32	R/W	0000_0000h	18.3.4/368
4000_D434	Region Descriptor n, Word 1 (MPU_RGD3_WORD1)	32	R/W	0000_001Fh	18.3.5/369
4000_D438	Region Descriptor n, Word 2 (MPU_RGD3_WORD2)	32	R/W	0000_0000h	18.3.6/369
4000_D43C	Region Descriptor n, Word 3 (MPU_RGD3_WORD3)	32	R/W	0000_0000h	18.3.7/372
4000_D440	Region Descriptor n, Word 0 (MPU_RGD4_WORD0)	32	R/W	0000_0000h	18.3.4/368
4000_D444	Region Descriptor n, Word 1 (MPU_RGD4_WORD1)	32	R/W	0000_001Fh	18.3.5/369
4000_D448	Region Descriptor n, Word 2 (MPU_RGD4_WORD2)	32	R/W	0000_0000h	18.3.6/369
4000_D44C	Region Descriptor n, Word 3 (MPU_RGD4_WORD3)	32	R/W	0000_0000h	18.3.7/372
4000_D450	Region Descriptor n, Word 0 (MPU_RGD5_WORD0)	32	R/W	0000_0000h	18.3.4/368
4000_D454	Region Descriptor n, Word 1 (MPU_RGD5_WORD1)	32	R/W	0000_001Fh	18.3.5/369
4000_D458	Region Descriptor n, Word 2 (MPU_RGD5_WORD2)	32	R/W	0000_0000h	18.3.6/369
4000_D45C	Region Descriptor n, Word 3 (MPU_RGD5_WORD3)	32	R/W	0000_0000h	18.3.7/372
4000_D460	Region Descriptor n, Word 0 (MPU_RGD6_WORD0)	32	R/W	0000_0000h	18.3.4/368
4000_D464	Region Descriptor n, Word 1 (MPU_RGD6_WORD1)	32	R/W	0000_001Fh	18.3.5/369
4000_D468	Region Descriptor n, Word 2 (MPU_RGD6_WORD2)	32	R/W	0000_0000h	18.3.6/369

Table continues on the next page...

MPU memory map (continued)

Absolute address (hex)	Register name	Width (in bits)	Access	Reset value	Section/page
4000_D46C	Region Descriptor n, Word 3 (MPU_RGD6_WORD3)	32	R/W	0000_0000h	18.3.7/372
4000_D470	Region Descriptor n, Word 0 (MPU_RGD7_WORD0)	32	R/W	0000_0000h	18.3.4/368
4000_D474	Region Descriptor n, Word 1 (MPU_RGD7_WORD1)	32	R/W	0000_001Fh	18.3.5/369
4000_D478	Region Descriptor n, Word 2 (MPU_RGD7_WORD2)	32	R/W	0000_0000h	18.3.6/369
4000_D47C	Region Descriptor n, Word 3 (MPU_RGD7_WORD3)	32	R/W	0000_0000h	18.3.7/372
4000_D480	Region Descriptor n, Word 0 (MPU_RGD8_WORD0)	32	R/W	0000_0000h	18.3.4/368
4000_D484	Region Descriptor n, Word 1 (MPU_RGD8_WORD1)	32	R/W	0000_001Fh	18.3.5/369
4000_D488	Region Descriptor n, Word 2 (MPU_RGD8_WORD2)	32	R/W	0000_0000h	18.3.6/369
4000_D48C	Region Descriptor n, Word 3 (MPU_RGD8_WORD3)	32	R/W	0000_0000h	18.3.7/372
4000_D490	Region Descriptor n, Word 0 (MPU_RGD9_WORD0)	32	R/W	0000_0000h	18.3.4/368
4000_D494	Region Descriptor n, Word 1 (MPU_RGD9_WORD1)	32	R/W	0000_001Fh	18.3.5/369
4000_D498	Region Descriptor n, Word 2 (MPU_RGD9_WORD2)	32	R/W	0000_0000h	18.3.6/369
4000_D49C	Region Descriptor n, Word 3 (MPU_RGD9_WORD3)	32	R/W	0000_0000h	18.3.7/372
4000_D4A0	Region Descriptor n, Word 0 (MPU_RGD10_WORD0)	32	R/W	0000_0000h	18.3.4/368
4000_D4A4	Region Descriptor n, Word 1 (MPU_RGD10_WORD1)	32	R/W	0000_001Fh	18.3.5/369
4000_D4A8	Region Descriptor n, Word 2 (MPU_RGD10_WORD2)	32	R/W	0000_0000h	18.3.6/369
4000_D4AC	Region Descriptor n, Word 3 (MPU_RGD10_WORD3)	32	R/W	0000_0000h	18.3.7/372
4000_D4B0	Region Descriptor n, Word 0 (MPU_RGD11_WORD0)	32	R/W	0000_0000h	18.3.4/368
4000_D4B4	Region Descriptor n, Word 1 (MPU_RGD11_WORD1)	32	R/W	0000_001Fh	18.3.5/369
4000_D4B8	Region Descriptor n, Word 2 (MPU_RGD11_WORD2)	32	R/W	0000_0000h	18.3.6/369
4000_D4BC	Region Descriptor n, Word 3 (MPU_RGD11_WORD3)	32	R/W	0000_0000h	18.3.7/372
4000_D800	Region Descriptor Alternate Access Control n (MPU_RGDAAC0)	32	R/W	0000_0000h	18.3.8/373
4000_D804	Region Descriptor Alternate Access Control n (MPU_RGDAAC1)	32	R/W	0000_0000h	18.3.8/373
4000_D808	Region Descriptor Alternate Access Control n (MPU_RGDAAC2)	32	R/W	0000_0000h	18.3.8/373
4000_D80C	Region Descriptor Alternate Access Control n (MPU_RGDAAC3)	32	R/W	0000_0000h	18.3.8/373
4000_D810	Region Descriptor Alternate Access Control n (MPU_RGDAAC4)	32	R/W	0000_0000h	18.3.8/373
4000_D814	Region Descriptor Alternate Access Control n (MPU_RGDAAC5)	32	R/W	0000_0000h	18.3.8/373
4000_D818	Region Descriptor Alternate Access Control n (MPU_RGDAAC6)	32	R/W	0000_0000h	18.3.8/373

Table continues on the next page...

MPU memory map (continued)

Absolute address (hex)	Register name	Width (in bits)	Access	Reset value	Section/page
4000_D81C	Region Descriptor Alternate Access Control n (MPU_RGDAAC7)	32	R/W	0000_0000h	18.3.8/373
4000_D820	Region Descriptor Alternate Access Control n (MPU_RGDAAC8)	32	R/W	0000_0000h	18.3.8/373
4000_D824	Region Descriptor Alternate Access Control n (MPU_RGDAAC9)	32	R/W	0000_0000h	18.3.8/373
4000_D828	Region Descriptor Alternate Access Control n (MPU_RGDAAC10)	32	R/W	0000_0000h	18.3.8/373
4000_D82C	Region Descriptor Alternate Access Control n (MPU_RGDAAC11)	32	R/W	0000_0000h	18.3.8/373

18.3.1 Control/Error Status Register (MPU_CESR)

Address: MPU_CESR is 4000_D000h base + 0h offset = 4000_D000h

Bit	31	30	29	28	27	26	25	24	23	22	21	20	19	18	17	16	15	14	13	12	11	10	9	8	7	6	5	4	3	2	1	0
R	SPERR				0	1	0	HRL				NSP		NRGD		0				VLD												
W	w1c																															
Reset	0	0	0	0	0	0	0	0	1	0	0	0	0	0	0	1	0	1	0	1	0	0	0	1	0	0	0	0	0	0	0	1

MPU_CESR field descriptions

Field	Description
31–27 SPERR	<p>Slave port n error</p> <p>Indicates a captured error in EARn and EDRn. This bit is set when the hardware detects an error and records the faulting address and attributes. It is cleared by writing one to it. If another error is captured at the exact same cycle as the write, the flag remains set. A find-first-one instruction (or equivalent) can detect the presence of a captured error.</p> <p>The following shows the correspondence between the bit number and slave port number:</p> <ul style="list-style-type: none"> • Bit 31 corresponds to slave port 0. • Bit 30 corresponds to slave port 1. • Bit 29 corresponds to slave port 2. • Bit 28 corresponds to slave port 3. • Bit 27 corresponds to slave port 4. <p>0 No error has occurred for slave port n. 1 An error has occurred for slave port n.</p>
26–24 Reserved	This read-only field is reserved and always has the value zero.
23 Reserved	This read-only field is reserved and always has the value one.

Table continues on the next page...

MPU_CESR field descriptions (continued)

Field	Description
22–20 Reserved	This read-only field is reserved and always has the value zero.
19–16 HRL	Hardware revision level Specifies the MPU's hardware and definition revision level. It can be read by software to determine the functional definition of the module.
15–12 NSP	Number of slave ports Specifies the number of slave ports connected to the MPU.
11–8 NRGD	Number of region descriptors Indicates the number of region descriptors implemented in the MPU. 0000 8 region descriptors 0001 12 region descriptors 0010 16 region descriptors
7–1 Reserved	This read-only field is reserved and always has the value zero.
0 VLD	Valid (global enable/disable for the MPU) 0 MPU is disabled. All accesses from all bus masters are allowed. 1 MPU is enabled

18.3.2 Error Address Register, Slave Port n (MPU_EARn)

When the MPU detects an access error on slave port n, the 32-bit reference address is captured in this read-only register and the corresponding bit in CESR[SPERR] set. Additional information about the faulting access is captured in the corresponding EDRn at the same time. This register and the corresponding EDRn contain the most recent access error; there are no hardware interlocks with CESR[SPERR], as the error registers are always loaded upon the occurrence of each protection violation.

Addresses: MPU_EAR0 is 4000_D000h base + 10h offset = 4000_D010h

MPU_EAR1 is 4000_D000h base + 18h offset = 4000_D018h

MPU_EAR2 is 4000_D000h base + 20h offset = 4000_D020h

MPU_EAR3 is 4000_D000h base + 28h offset = 4000_D028h

MPU_EAR4 is 4000_D000h base + 30h offset = 4000_D030h

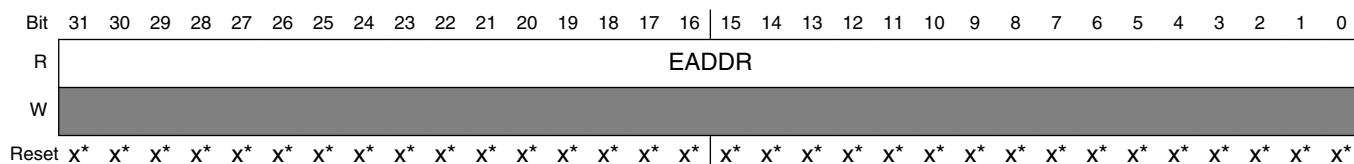

- * Notes:
- x = Undefined at reset.

MPU_EARn field descriptions

Field	Description
31–0 EADDR	Error address Indicates the reference address from slave port n that generated the access error

18.3.3 Error Detail Register, Slave Port n (MPU_EDRn)

When the MPU detects an access error on slave port n, 32 bits of error detail are captured in this read-only register and the corresponding bit in CESR[SPERR] is set. Information on the faulting address is captured in the corresponding EARn register at the same time. This register and the corresponding EARn register contain the most recent access error; there are no hardware interlocks with CESR[SPERR] as the error registers are always loaded upon the occurrence of each protection violation.

Addresses: MPU_EDR0 is 4000_D000h base + 14h offset = 4000_D014h

MPU_EDR1 is 4000_D000h base + 1Ch offset = 4000_D01Ch

MPU_EDR2 is 4000_D000h base + 24h offset = 4000_D024h

MPU_EDR3 is 4000_D000h base + 2Ch offset = 4000_D02Ch

MPU_EDR4 is 4000_D000h base + 34h offset = 4000_D034h

Bit	31	30	29	28	27	26	25	24	23	22	21	20	19	18	17	16
R	EACD															
W																
Reset	x*	x*	x*	x*	x*	x*	x*	x*	x*	x*	x*	x*	x*	x*	x*	x*
Bit	15	14	13	12	11	10	9	8	7	6	5	4	3	2	1	0
R	0								EMN				EATTR			ERW
W																
Reset	x*	x*	x*	x*	x*	x*	x*	x*	x*	x*	x*	x*	x*	x*	x*	x*

* Notes:

- x = Undefined at reset.

MPU_EDRn field descriptions

Field	Description
31–16 EACD	Error access control detail Indicates the region descriptor with the access error. If EDRn contains a captured error and EACD is cleared, an access did not hit in any region descriptor. If only a single EACD bit is set, the protection error was caused by a single non-overlapping region descriptor. If two or more EACD bits are set, the protection error was caused by an overlapping set of region descriptors.
15–8 Reserved	This read-only field is reserved and always has the value zero.
7–4 EMN	Error master number Indicates the bus master that generated the access error.
3–1 EATTR	Error attributes Indicates attribute information about the faulting reference.

Table continues on the next page...

MPU_EDR_n field descriptions (continued)

Field	Description
	<p>NOTE: All other encodings are reserved.</p> <p>000 User mode, instruction access 001 User mode, data access 010 Supervisor mode, instruction access 011 Supervisor mode, data access</p>
0 ERW	<p>Error read/write</p> <p>Indicates the access type of the faulting reference.</p> <p>0 Read 1 Write</p>

18.3.4 Region Descriptor n, Word 0 (MPU_RGD_WORD0)

The first word of the region descriptor defines the 0-modulo-32 byte start address of the memory region. Writes to this register clear the region descriptor’s valid bit (RGD_n_WORD3[VLD]).

Addresses: 4000_D000h base + 400h offset + (16d × n), where n = 0d to 11d

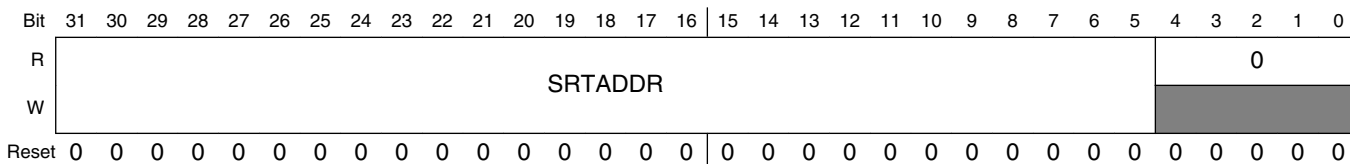

MPU_RGD_n_WORD0 field descriptions

Field	Description
31–5 SRTADDR	<p>Start address</p> <p>Defines the most significant bits of the 0-modulo-32 byte start address of the memory region.</p>
4–0 Reserved	<p>This read-only field is reserved and always has the value zero.</p>

18.3.5 Region Descriptor n, Word 1 (MPU_RGD_WORD1)

The second word of the region descriptor defines the 31-modulo-32 byte end address of the memory region. Writes to this register clear the region descriptor’s valid bit (RGDn_WORD3[VLD]).

Addresses: 4000_D000h base + 404h offset + (16d × n), where n = 0d to 11d

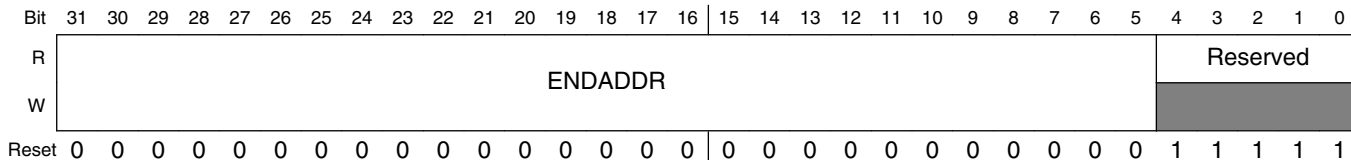

MPU_RGDn_WORD1 field descriptions

Field	Description
31–5 ENDADDR	End address Defines the most significant bits of the 31-modulo-32 byte end address of the memory region. NOTE: The MPU does not verify that ENDADDR ≥ SRTADDR.
4–0 Reserved	This field is reserved.

18.3.6 Region Descriptor n, Word 2 (MPU_RGD_WORD2)

The third word of the region descriptor defines the access control rights of the memory region. The access control privileges depend on two broad classifications of bus masters:

- Bus masters 0–3 have a 5-bit field defining separate privilege rights for user and supervisor mode accesses.
- Bus masters 4–7 are limited to separate read and write permissions.

For the privilege rights of bus masters 0–3, there are three flags associated with this function:

- Read (r) refers to accessing the referenced memory address using an operand (data) fetch
- Write (w) refers to updating the referenced memory address using a store (data) instruction
- Execute (x) refers to reading the referenced memory address using an instruction fetch

Writes to RGDn_WORD2 clear the region descriptor's valid bit (RGDn_WORD3[VLD]). If only updating the access controls, write to RGDAACn instead because stores to these locations do not affect the descriptor's valid bit.

Addresses: 4000_D000h base + 408h offset + (16d × n), where n = 0d to 11d

Bit	31	30	29	28	27	26	25	24	23	22	21	20	19	18	17	16
R									Reserved	M3SM		M3UM			Reserved	M2SM [-14:1]
W	M7RE	M7WE	M6RE	M6WE	M5RE	M5WE	M4RE	M4WE								
Reset	0	0	0	0	0	0	0	0	0	0	0	0	0	0	0	0
Bit	15	14	13	12	11	10	9	8	7	6	5	4	3	2	1	0
R	M2SM [bit 0]	M2UM			Reserved	M1SM		M1UM			Reserved	M0SM		M0UM		
W																
Reset	0	0	0	0	0	0	0	0	0	0	0	0	0	0	0	0

MPU_RGDn_WORD2 field descriptions

Field	Description
31 M7RE	Bus master 7 read enable. 0 Bus master 7 reads terminate with an access error and the read is not performed 1 Bus master 7 reads allowed
30 M7WE	Bus master 7 write enable 0 Bus master 7 writes terminate with an access error and the write is not performed 1 Bus master 7 writes allowed
29 M6RE	Bus master 6 read enable. 0 Bus master 6 reads terminate with an access error and the read is not performed 1 Bus master 6 reads allowed
28 M6WE	Bus master 6 write enable 0 Bus master 6 writes terminate with an access error and the write is not performed 1 Bus master 6 writes allowed
27 M5RE	Bus master 5 read enable. 0 Bus master 5 reads terminate with an access error and the read is not performed 1 Bus master 5 reads allowed
26 M5WE	Bus master 5 write enable 0 Bus master 5 writes terminate with an access error and the write is not performed 1 Bus master 5 writes allowed
25 M4RE	Bus master 4 read enable.

Table continues on the next page...

MPU_RGDn_WORD2 field descriptions (continued)

Field	Description
	0 Bus master 4 reads terminate with an access error and the read is not performed 1 Bus master 4 reads allowed
24 M4WE	Bus master 4 write enable 0 Bus master 4 writes terminate with an access error and the write is not performed 1 Bus master 4 writes allowed
23 Reserved	This field is reserved. This bit must be written with a zero.
22–21 M3SM	Bus master 3 supervisor mode access control Defines the access controls for bus master 3 in supervisor mode 00 r/w/x; read, write and execute allowed 01 r/x; read and execute allowed, but no write 10 r/w; read and write allowed, but no execute 11 Same as user mode defined in M3UM
20–18 M3UM	Bus master 3 user mode access control Defines the access controls for bus master 3 in user mode. M3UM consists of three independent bits, enabling read (r), write (w), and execute (x) permissions. 0 An attempted access of that mode may be terminated with an access error (if not allowed by another descriptor) and the access not performed. 1 Allows the given access type to occur
17 Reserved	This field is reserved. This bit must be written with a zero.
16–15 M2SM	Bus master 2 supervisor mode access control See M3SM description
14–12 M2UM	Bus master 2 user mode access control See M3UM description
11 Reserved	This field is reserved. This bit must be written with a zero.
10–9 M1SM	Bus master 1 supervisor mode access control See M3SM description
8–6 M1UM	Bus master 1 user mode access control See M3UM description
5 Reserved	This field is reserved. This bit must be written with a zero.
4–3 M0SM	Bus master 0 supervisor mode access control See M3SM description
2–0 M0UM	Bus master 0 user mode access control

Table continues on the next page...

MPU_RGDn_WORD2 field descriptions (continued)

Field	Description
	See M3UM description

18.3.7 Region Descriptor n, Word 3 (MPU_RGD_WORD3)

The fourth word of the region descriptor contains the region descriptor's valid bit.

Addresses: 4000_D000h base + 40Ch offset + (16d × n), where n = 0d to 11d

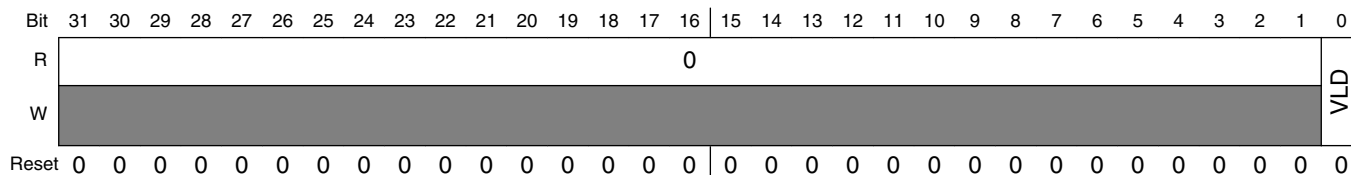

MPU_RGDn_WORD3 field descriptions

Field	Description
31–1 Reserved	This read-only field is reserved and always has the value zero.
0 VLD	Valid Signals the region descriptor is valid. Any write to RGDn_WORD0–2 clears this bit. 0 Region descriptor is invalid 1 Region descriptor is valid

18.3.8 Region Descriptor Alternate Access Control n (MPU_RGDAACn)

Since software may adjust only the access controls within a region descriptor (RGDn_WORD2) as different tasks execute, an alternate programming view of this 32-bit entity is available. Writing to this register does not affect the descriptor's valid bit.

Addresses: 4000_D000h base + 800h offset + (4d × n), where n = 0d to 11d

Bit	31	30	29	28	27	26	25	24	23	22	21	20	19	18	17	16
R									Reserved	M3SM		M3UM		Reserved	M2SM [-14:1]	
W	M7RE	M7WE	M6RE	M6WE	M5RE	M5WE	M4RE	M4WE	Reserved	M3SM		M3UM		Reserved	M2SM [-14:1]	
Reset	0	0	0	0	0	0	0	0	0	0	0	0	0	0	0	0
Bit	15	14	13	12	11	10	9	8	7	6	5	4	3	2	1	0
R	M2SM [bit 0]	M2UM			Reserved	M1SM		M1UM			Reserved	M0SM		M0UM		
W	M2SM [bit 0]	M2UM			Reserved	M1SM		M1UM			Reserved	M0SM		M0UM		
Reset	0	0	0	0	0	0	0	0	0	0	0	0	0	0	0	0

MPU_RGDAACn field descriptions

Field	Description
31 M7RE	Bus master 7 read enable. 0 Bus master 7 reads terminate with an access error and the read is not performed 1 Bus master 7 reads allowed
30 M7WE	Bus master 7 write enable 0 Bus master 7 writes terminate with an access error and the write is not performed 1 Bus master 7 writes allowed
29 M6RE	Bus master 6 read enable. 0 Bus master 6 reads terminate with an access error and the read is not performed 1 Bus master 6 reads allowed
28 M6WE	Bus master 6 write enable 0 Bus master 6 writes terminate with an access error and the write is not performed 1 Bus master 6 writes allowed
27 M5RE	Bus master 5 read enable. 0 Bus master 5 reads terminate with an access error and the read is not performed 1 Bus master 5 reads allowed
26 M5WE	Bus master 5 write enable

Table continues on the next page...

MPU_RGDAACn field descriptions (continued)

Field	Description
	0 Bus master 5 writes terminate with an access error and the write is not performed 1 Bus master 5 writes allowed
25 M4RE	Bus master 4 read enable. 0 Bus master 4 reads terminate with an access error and the read is not performed 1 Bus master 4 reads allowed
24 M4WE	Bus master 4 write enable 0 Bus master 4 writes terminate with an access error and the write is not performed 1 Bus master 4 writes allowed
23 Reserved	This field is reserved. This bit must be written with a zero.
22–21 M3SM	Bus master 3 supervisor mode access control Defines the access controls for bus master 3 in supervisor mode 00 r/w/x; read, write and execute allowed 01 r/x; read and execute allowed, but no write 10 r/w; read and write allowed, but no execute 11 Same as user mode defined in M3UM
20–18 M3UM	Bus master 3 user mode access control Defines the access controls for bus master 3 in user mode. M3UM consists of three independent bits, enabling read (r), write (w), and execute (x) permissions. 0 An attempted access of that mode may be terminated with an access error (if not allowed by another descriptor) and the access not performed. 1 Allows the given access type to occur
17 Reserved	This field is reserved. This bit must be written with a zero.
16–15 M2SM	Bus master 2 supervisor mode access control See M3SM description.
14–12 M2UM	Bus master 2 user mode access control See M3UM description.
11 Reserved	This field is reserved. This bit must be written with a zero.
10–9 M1SM	Bus master 1 supervisor mode access control See M3SM description.
8–6 M1UM	Bus master 1 user mode access control See M3UM description.
5 Reserved	This field is reserved. This bit must be written with a zero.

Table continues on the next page...

MPU_RGDAAC_n field descriptions (continued)

Field	Description
4–3 M0SM	Bus master 0 supervisor mode access control See M3SM description.
2–0 M0UM	Bus master 0 user mode access control See M3UM description.

18.4 Functional Description

In this section, the functional operation of the MPU is detailed, including the operation of the access evaluation macro and the handling of error-terminated bus cycles.

18.4.1 Access Evaluation Macro

The basic operation of the MPU is performed in the access evaluation macro, a hardware structure replicated in the two-dimensional connection matrix. As shown in the following figure, the access evaluation macro inputs the crossbar bus address phase signals and the contents of a region descriptor (RGD_n) and performs two major functions: region hit determination and detection of an access protection violation. The following figure shows a functional block diagram.

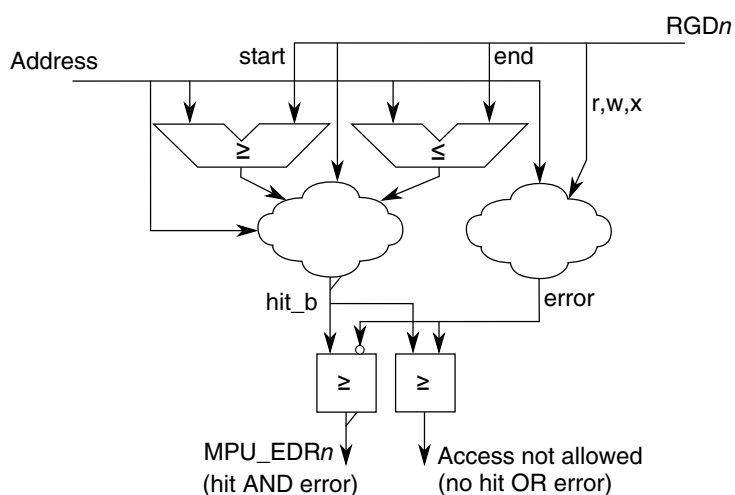

Figure 18-80. MPU Access Evaluation Macro

18.4.1.1 Hit Determination

To determine if the current reference hits in the given region, two magnitude comparators are used with the region's start and end addresses. The boolean equation for this portion of the hit determination is:

$$\text{region_hit} = ((\text{addr}[31:5] \geq \text{RGDn_Word0}[\text{SRTADDR}]) \& (\text{addr}[31:5] \leq \text{RGDn_Word1}[\text{ENDADDR}])) \& \text{RGDn_Word3}[\text{VLD}]$$

where *addr* is the current reference address, *RGDn_Word0*[SRTADDR] and *RGDn_Word1*[ENDADDR] are the start and end addresses, and *RGDn_Word3*[VLD] is the valid bit.

NOTE

The MPU does not verify that $\text{ENDADDR} \geq \text{SRTADDR}$.

18.4.1.2 Privilege Violation Determination

While the access evaluation macro is determining region hit, the logic is also evaluating if the current access is allowed by the permissions defined in the region descriptor. Using the master and supervisor/user mode signals, a set of effective permissions is generated from the appropriate fields in the region descriptor. The protection violation logic then evaluates the access against the effective permissions using the specification shown below.

Table 18-80. Protection Violation Definition

Description	MxUM			Protection Violation?
	r	w	x	
Instruction fetch read	—	—	0	Yes, no execute permission
	—	—	1	No, access is allowed
Data read	0	—	—	Yes, no read permission
	1	—	—	No, access is allowed
Data write	—	0	—	Yes, no write permission
	—	1	—	No, access is allowed

18.4.2 Putting It All Together and Error Terminations

For each slave port monitored, the MPU performs a reduction-AND of all the individual terms from each access evaluation macro. This expression then terminates the bus cycle with an error and reports a protection error for three conditions:

1. If the access does not hit in any region descriptor, a protection error is reported.
2. If the access hits in a single region descriptor and that region signals a protection violation, a protection error is reported.
3. If the access hits in multiple (overlapping) regions and all regions signal protection violations, a protection error is reported.

As shown in the third condition, granting permission is a higher priority than denying access for overlapping regions. This approach is more flexible to system software in region descriptor assignments. For an example of the use of overlapping region descriptors, see [Application Information](#).

18.4.3 Power Management

Disabling the MPU by clearing CESR[VLD] minimizes power dissipation. To minimize the power dissipation of an enabled MPU, invalidate unused region descriptors by clearing the associated RGDn_Word3[VLD] bits.

18.5 Initialization Information

At system startup, load the appropriate number of region descriptors, including setting RGDn_Word3[VLD]. Setting CESR[VLD] enables the module.

If the system requires that all the loaded region descriptors be enabled simultaneously, first ensure that the entire MPU is disabled (CESR[VLD]=0).

Note

A region descriptor must be set to allow access to the MPU registers if further changes are needed.

18.6 Application Information

In an operational system, interfacing with the MPU is generally classified into the following activities:

- Creating a new memory region—Load the appropriate region descriptor into an available RGD n , using four sequential 32-bit writes. The hardware assists in the maintenance of the valid bit, so if this approach is followed, there are no coherency issues with the multi-cycle descriptor writes. (Clearing RGD n _Word3[VLD] deletes/removes an existing memory region.)
- Altering only access privileges—To not affect the valid bit, write to the alternate version of the access control word (RGDAAC n), so there are no coherency issues involved with the update. When the write completes, the memory region's access rights switch instantaneously to the new value.
- Changing a region's start and end addresses—Write a minimum of three words to the region descriptor (RGD n _Word{0,1,3}). Word 0 and 1 redefine the start and end addresses, respectively. Word 3 re-enables the region descriptor valid bit. In most situations, all four words of the region descriptor are rewritten.
- Accessing the MPU—Allocate a region descriptor to restrict MPU access to supervisor mode from a specific master.
- Detecting an access error—The current bus cycle is terminated with an error response and EAR n and EDR n capture information on the faulting reference. The error-terminated bus cycle typically initiates an error response in the originating bus master. For example, a processor core may respond with a bus error exception, while a data movement bus master may respond with an error interrupt. The processor can retrieve the captured error address and detail information simply by reading E{A,D}R n . CESR[SPERR] signals which error registers contain captured fault data.
- Overlapping region descriptors—Applying overlapping regions often reduces the number of descriptors required for a given set of access controls. In the overlapping memory space, the protection rights of the corresponding region descriptors are logically summed together (the boolean OR operator).

The following dual-core system example contains four bus masters: the two processors (CP0, CP1) and two DMA engines (DMA1, a traditional data movement engine transferring data between RAM and peripherals and DMA2, a second engine transferring data to/from the RAM only). Consider the following region descriptor assignments:

Table 18-81. Overlapping Region Descriptor Example

Region Description	RGD n	CP0	CP1	DMA1	DMA2	
CP0 code	0	rwx	r--	—	—	Flash
CP1 code	1	r--	rwx	—	—	

Table continues on the next page...

Table 18-81. Overlapping Region Descriptor Example (continued)

Region Description	RGDn	CP0	CP1	DMA1	DMA2	
CP0 data & stack	2	rw-	—	—	—	RAM
CP0 → CP1 shared data	2	r--	r--	—	—	
CP1 → CP0 shared data	4					
CP1 data & stack	4	—	rw-	—	—	
Shared DMA data	5	rw-	rw-	rw	rw	
MPU	6	rw-	rw-	—	—	Peripheral space
Peripherals	7	rw-	rw-	rw	—	

In this example, there are eight descriptors used to span nine regions in the three main spaces of the system memory map (flash, RAM, and peripheral space). Each region indicates the specific permissions for each of the four bus masters and this definition provides an appropriate set of shared, private and executable memory spaces.

Of particular interest are the two overlapping spaces: region descriptors 2 & 3 and 3 & 4.

The space defined by RGD2 with no overlap is a private data and stack area that provides read/write access to CP0 only. The overlapping space between RGD2 and RGD3 defines a shared data space for passing data from CP0 to CP1 and the access controls are defined by the logical OR of the two region descriptors. Thus, CP0 has (rw- | r--) = (rw-) permissions, while CP1 has (--- | r--) = (r--) permission in this space. Both DMA engines are excluded from this shared processor data region. The overlapping spaces between RGD3 and RGD4 defines another shared data space, this one for passing data from CP1 to CP0. For this overlapping space, CP0 has (r-- | ---) = (r--) permission, while CP1 has (rw- | r--) = (rw-) permission. The non-overlapped space of RGD4 defines a private data and stack area for CP1 only.

The space defined by RGD5 is a shared data region, accessible by all four bus masters. Finally, the slave peripheral space mapped onto the IPS bus is partitioned into two regions: one containing the MPU's programming model accessible only to the two processor cores and the remaining peripheral region accessible to both processors and the traditional DMA1 master.

This simple example is intended to show one possible application of the capabilities of the MPU in a typical system.



Chapter 19

Peripheral Bridge (AIPS-Lite)

19.1 Introduction

NOTE

For the chip-specific implementation details of this module's instances see the chip configuration chapter.

The peripheral bridge (AIPS-Lite) converts the crossbar switch interface to an interface to access a majority of peripherals on the device.

The peripheral bridge supports up to 128 peripherals. The peripheral bridge occupies a 64 MB portion of the address space. The bridge includes separate clock enable inputs for each of the slots to accommodate slower peripherals.

19.1.1 Features

Key features of the peripheral bridge are:

- Supports up to 128 peripherals
- Supports 8-, 16-, and 32-bit width peripheral slots
- Each independently configurable peripheral includes a clock enable, which allows peripherals to operate at any speed less than the system clock rate.
- Programming model provides memory protection functionality

19.1.2 General operation

The peripherals connected to the peripheral bridge are modules that contain readable/writable control and status registers. The system masters read and write these registers through the peripheral bridge. The peripheral bridge generates module enables, the

module address, transfer attributes, byte enables, and write data as inputs to the peripherals. The peripheral bridge captures read data from the peripheral interface and drives it to the crossbar switch.

The register maps of the peripherals are located on 4 KB boundaries. Each peripheral is allocated one 4 KB block of the memory map.

The peripheral bridge (AIPS-Lite) memory map is illustrated as follows.

Addresses	Description
Base + 0x000_0000 - 0x000_0FFF	Module #0
Base + 0x000_1000 - 0x000_1FFF	Module #1
...	...
Base + 0x007_F000 - 0x007_FFFF	Module #127

19.2 Memory map/register definition

The peripheral bridge registers are 32-bit registers and can only be accessed in supervisor mode by trusted bus masters. Additionally, these registers must only be read from or written to by a 32-bit aligned access. The peripheral bridge registers are mapped into the PACR0 address space.

Two system clocks are required for read accesses, and three system clocks are required for write accesses to the peripheral bridge registers.

NOTE

The number of fields and registers available depends on the device-specific implementation of the peripheral bridge module. See the Chip Configuration chapter for more information.

AIPS memory map

Absolute address (hex)	Register name	Width (in bits)	Access	Reset value	Section/page
4000_0000	Master Privilege Register A (AIPS0_MPRA)	32	R/W	Undefined	19.2.1/383
4000_0020	Peripheral Access Control Register (AIPS0_PACRA)	32	R/W	4444_4444h	19.2.2/387
4000_0024	Peripheral Access Control Register (AIPS0_PACRB)	32	R/W	4444_4444h	19.2.2/387
4000_0028	Peripheral Access Control Register (AIPS0_PACRC)	32	R/W	4444_4444h	19.2.2/387
4000_002C	Peripheral Access Control Register (AIPS0_PACRD)	32	R/W	4444_4444h	19.2.2/387

Table continues on the next page...

AIPS memory map (continued)

Absolute address (hex)	Register name	Width (in bits)	Access	Reset value	Section/page
4000_0040	Peripheral Access Control Register (AIPS0_PACRE)	32	R/W	Undefined	19.2.3/392
4000_0044	Peripheral Access Control Register (AIPS0_PACRF)	32	R/W	Undefined	19.2.3/392
4000_0048	Peripheral Access Control Register (AIPS0_PACRG)	32	R/W	Undefined	19.2.3/392
4000_004C	Peripheral Access Control Register (AIPS0_PACRH)	32	R/W	Undefined	19.2.3/392
4000_0050	Peripheral Access Control Register (AIPS0_PACRI)	32	R/W	Undefined	19.2.3/392
4000_0054	Peripheral Access Control Register (AIPS0_PACRJ)	32	R/W	Undefined	19.2.3/392
4000_0058	Peripheral Access Control Register (AIPS0_PACRK)	32	R/W	Undefined	19.2.3/392
4000_005C	Peripheral Access Control Register (AIPS0_PACRL)	32	R/W	Undefined	19.2.3/392
4000_0060	Peripheral Access Control Register (AIPS0_PACRM)	32	R/W	Undefined	19.2.3/392
4000_0064	Peripheral Access Control Register (AIPS0_PACRN)	32	R/W	Undefined	19.2.3/392
4000_0068	Peripheral Access Control Register (AIPS0_PACRO)	32	R/W	Undefined	19.2.3/392
4000_006C	Peripheral Access Control Register (AIPS0_PACRP)	32	R/W	Undefined	19.2.3/392
4008_0000	Master Privilege Register A (AIPS1_MPRA)	32	R/W	Undefined	19.2.1/383
4008_0020	Peripheral Access Control Register (AIPS1_PACRA)	32	R/W	4444_4444h	19.2.2/387
4008_0024	Peripheral Access Control Register (AIPS1_PACRB)	32	R/W	4444_4444h	19.2.2/387
4008_0028	Peripheral Access Control Register (AIPS1_PACRC)	32	R/W	4444_4444h	19.2.2/387
4008_002C	Peripheral Access Control Register (AIPS1_PACRD)	32	R/W	4444_4444h	19.2.2/387
4008_0040	Peripheral Access Control Register (AIPS1_PACRE)	32	R/W	Undefined	19.2.3/392
4008_0044	Peripheral Access Control Register (AIPS1_PACRF)	32	R/W	Undefined	19.2.3/392
4008_0048	Peripheral Access Control Register (AIPS1_PACRG)	32	R/W	Undefined	19.2.3/392
4008_004C	Peripheral Access Control Register (AIPS1_PACRH)	32	R/W	Undefined	19.2.3/392
4008_0050	Peripheral Access Control Register (AIPS1_PACRI)	32	R/W	Undefined	19.2.3/392
4008_0054	Peripheral Access Control Register (AIPS1_PACRJ)	32	R/W	Undefined	19.2.3/392
4008_0058	Peripheral Access Control Register (AIPS1_PACRK)	32	R/W	Undefined	19.2.3/392
4008_005C	Peripheral Access Control Register (AIPS1_PACRL)	32	R/W	Undefined	19.2.3/392
4008_0060	Peripheral Access Control Register (AIPS1_PACRM)	32	R/W	Undefined	19.2.3/392
4008_0064	Peripheral Access Control Register (AIPS1_PACRN)	32	R/W	Undefined	19.2.3/392
4008_0068	Peripheral Access Control Register (AIPS1_PACRO)	32	R/W	Undefined	19.2.3/392
4008_006C	Peripheral Access Control Register (AIPS1_PACRP)	32	R/W	Undefined	19.2.3/392

19.2.1 Master Privilege Register A (AIPSx_MPRA)

The MPRA register specifies identical 4-bit fields defining the access-privilege level associated with a bus master in the device to the various peripherals. The register provides one field per bus master.

NOTE

At reset, the default value loaded into the MPROT[7-0] fields is device-specific. See the Chip Configuration details for the value on your particular device.

Accesses to registers or register fields which correspond to master or peripheral locations which are not implemented return zeros on reads, and are ignored on writes.

Each master is assigned depending on its connection to the crossbar switch master ports. See your device-specific Chip Configuration details for information about the master assignments to these registers.

Addresses: AIPSO_MPRA is 4000_0000h base + 0h offset = 4000_0000h

AIPS1_MPRA is 4008_0000h base + 0h offset = 4008_0000h

Bit	31	30	29	28	27	26	25	24	23	22	21	20	19	18	17	16	15	14	13	12	11	10	9	8	7	6	5	4	3	2	1	0
R	0	MTR0	MTW0	MPL0	0	MTR1	MTW1	MPL1	0	MTR2	MTW2	MPL2	0	MTR3	MTW3	MPL3	0	MTR4	MTW4	MPL4	0	MTR5	MTW5	MPL5	0				0			
W																																
Reset	x*	x*	x*	x*	x*	x*	x*	x*	x*	x*	x*	x*	x*	x*	x*	x*	x*	x*	x*	x*	x*	x*	x*	x*	x*	x*	x*	x*	x*	x*	x*	

* Notes:

- x = Undefined at reset.

AIPStx_MPRA field descriptions

Field	Description
31 Reserved	This read-only field is reserved and always has the value zero.
30 MTR0	Master trusted for read Determines whether the master is trusted for read accesses. 0 This master is not trusted for read accesses. 1 This master is trusted for read accesses.
29 MTW0	Master trusted for writes Determines whether the master is trusted for write accesses. 0 This master is not trusted for write accesses. 1 This master is trusted for write accesses.
28 MPL0	Master privilege level Specifies how the privilege level of the master is determined. 0 Accesses from this master are forced to user-mode. 1 Accesses from this master are not forced to user-mode.
27 Reserved	This read-only field is reserved and always has the value zero.

Table continues on the next page...

AIPSx_MPRA field descriptions (continued)

Field	Description
26 MTR1	Master trusted for read Determines whether the master is trusted for read accesses. 0 This master is not trusted for read accesses. 1 This master is trusted for read accesses.
25 MTW1	Master trusted for writes Determines whether the master is trusted for write accesses. 0 This master is not trusted for write accesses. 1 This master is trusted for write accesses.
24 MPL1	Master privilege level Specifies how the privilege level of the master is determined. 0 Accesses from this master are forced to user-mode. 1 Accesses from this master are not forced to user-mode.
23 Reserved	This read-only field is reserved and always has the value zero.
22 MTR2	Master trusted for read Determines whether the master is trusted for read accesses. 0 This master is not trusted for read accesses. 1 This master is trusted for read accesses.
21 MTW2	Master trusted for writes Determines whether the master is trusted for write accesses. 0 This master is not trusted for write accesses. 1 This master is trusted for write accesses.
20 MPL2	Master privilege level Specifies how the privilege level of the master is determined. 0 Accesses from this master are forced to user-mode. 1 Accesses from this master are not forced to user-mode.
19 Reserved	This read-only field is reserved and always has the value zero.
18 MTR3	Master trusted for read Determines whether the master is trusted for read accesses. 0 This master is not trusted for read accesses. 1 This master is trusted for read accesses.
17 MTW3	Master trusted for writes Determines whether the master is trusted for write accesses.

Table continues on the next page...

AIPSx_MPRA field descriptions (continued)

Field	Description
	0 This master is not trusted for write accesses. 1 This master is trusted for write accesses.
16 MPL3	Master privilege level Specifies how the privilege level of the master is determined. 0 Accesses from this master are forced to user-mode. 1 Accesses from this master are not forced to user-mode.
15 Reserved	This read-only field is reserved and always has the value zero.
14 MTR4	Master trusted for read Determines whether the master is trusted for read accesses. 0 This master is not trusted for read accesses. 1 This master is trusted for read accesses.
13 MTW4	Master trusted for writes Determines whether the master is trusted for write accesses. 0 This master is not trusted for write accesses. 1 This master is trusted for write accesses.
12 MPL4	Master privilege level Specifies how the privilege level of the master is determined. 0 Accesses from this master are forced to user-mode. 1 Accesses from this master are not forced to user-mode.
11 Reserved	This read-only field is reserved and always has the value zero.
10 MTR5	Master trusted for read Determines whether the master is trusted for read accesses. 0 This master is not trusted for read accesses. 1 This master is trusted for read accesses.
9 MTW5	Master trusted for writes Determines whether the master is trusted for write accesses. 0 This master is not trusted for write accesses. 1 This master is trusted for write accesses.
8 MPL5	Master privilege level Specifies how the privilege level of the master is determined. 0 Accesses from this master are forced to user-mode. 1 Accesses from this master are not forced to user-mode.
7-4 Reserved	This read-only field is reserved and always has the value zero.

Table continues on the next page...

AIPSx_MPRA field descriptions (continued)

Field	Description
3-0 Reserved	This read-only field is reserved and always has the value zero.

19.2.2 Peripheral Access Control Register (AIPSx_PACRn)

Each of the peripherals has a four-bit PACR[0:127] field which defines the access levels supported by the given module. Eight PACR fields are grouped together to form a 32-bit PACR[A:P] register:

- PACRA-P define the access levels for the 128 peripherals

The peripheral assignments to each PACR register is defined by the memory map slot that the peripherals are assigned. See the device's Memory Map details for the assignments for your particular device.

NOTE

The reset value of the PACRA-D registers is 0x4444_4444.

The following table shows the top-level structure of the PACR registers.

Offset	Register	[31:28]	[27:24]	[23:20]	[19:16]	[15:12]	[11:8]	[7:4]	[3:0]
0x20	PACRA	PACR0	PACR1	PACR2	PACR3	PACR4	PACR5	PACR6	PACR7
0x24	PACRB	PACR8	PACR9	PACR10	PACR11	PACR12	PACR13	PACR14	PACR15
0x28	PACRC	PACR16	PACR17	PACR18	PACR19	PACR20	PACR21	PACR22	PACR23
0x2C	PACRD	PACR24	PACR25	PACR26	PACR27	PACR28	PACR29	PACR30	PACR31
0x30	Reserved								
0x34	Reserved								
0x38	Reserved								
0x3C	Reserved								
0x40	PACRE	PACR32	PACR33	PACR34	PACR35	PACR36	PACR37	PACR38	PACR39
0x44	PACRF	PACR40	PACR41	PACR42	PACR43	PACR44	PACR45	PACR46	PACR47
0x48	PACRG	PACR48	PACR49	PACR50	PACR51	PACR52	PACR53	PACR54	PACR55
0x4C	PACRH	PACR56	PACR57	PACR58	PACR59	PACR60	PACR61	PACR62	PACR63
0x50	PACRI	PACR64	PACR65	PACR66	PACR67	PACR68	PACR69	PACR70	PACR71
0x54	PACRJ	PACR72	PACR73	PACR74	PACR75	PACR76	PACR77	PACR78	PACR79
0x58	PACRK	PACR80	PACR81	PACR82	PACR83	PACR84	PACR85	PACR86	PACR87
0x5C	PACRL	PACR88	PACR89	PACR90	PACR91	PACR92	PACR93	PACR94	PACR95

Table continues on the next page...

memory map/register definition

Offset	Register	[31:28]	[27:24]	[23:20]	[19:16]	[15:12]	[11:8]	[7:4]	[3:0]
0x60	PACRM	PACR96	PACR97	PACR98	PACR99	PACR100	PACR101	PACR102	PACR103
0x64	PACRN	PACR104	PACR105	PACR106	PACR107	PACR108	PACR109	PACR110	PACR111
0x68	PACRO	PACR112	PACR113	PACR114	PACR115	PACR116	PACR117	PACR118	PACR119
0x6C	PACRP	PACR120	PACR121	PACR122	PACR123	PACR124	PACR125	PACR126	PACR127

Addresses: AIPS0_PACRA is 4000_0000h base + 20h offset = 4000_0020h

AIPS0_PACRB is 4000_0000h base + 24h offset = 4000_0024h

AIPS0_PACRC is 4000_0000h base + 28h offset = 4000_0028h

AIPS0_PACRD is 4000_0000h base + 2Ch offset = 4000_002Ch

AIPS1_PACRA is 4008_0000h base + 20h offset = 4008_0020h

AIPS1_PACRB is 4008_0000h base + 24h offset = 4008_0024h

AIPS1_PACRC is 4008_0000h base + 28h offset = 4008_0028h

AIPS1_PACRD is 4008_0000h base + 2Ch offset = 4008_002Ch

Bit	31	30	29	28	27	26	25	24	23	22	21	20	19	18	17	16	15	14	13	12	11	10	9	8	7	6	5	4	3	2	1	0
R	0			0				0				0				0				0			0			0						
W		SP0	WP0	TP0		SP1	WP1	TP1		SP2	WP2	TP2		SP3	WP3	TP3		SP4	WP4	TP4		SP5	WP5	TP5		SP6	WP6	TP6		SP7	WP7	TP7
Reset	0	1	0	0	0	1	0	0	0	1	0	0	0	1	0	0	0	1	0	0	0	1	0	0	0	1	0	0	0	1	0	0

AIPSx_PACRn field descriptions

Field	Description
31 Reserved	This read-only field is reserved and always has the value zero.
30 SP0	Supervisor protect Determines whether the peripheral requires supervisor privilege level for access. When this bit is set, the master privilege level must indicate the supervisor access attribute , and the MPROTn[MPL] control bit for the master must be set. If not, access terminates with an error response and no peripheral access initiates. 0 This peripheral does not require supervisor privilege level for accesses. 1 This peripheral requires supervisor privilege level for accesses.
29 WP0	Write protect Determines whether the peripheral allows write accesses. When this bit is set and a write access is attempted, access terminates with an error response and no peripheral access initiates. 0 This peripheral allows write accesses. 1 This peripheral is write protected.
28 TP0	Trusted protect Determines whether the peripheral allows accesses from an untrusted master. When this bit is set and an access is attempted by an untrusted master, the access terminates with an error response and no peripheral access initiates. 0 Accesses from an untrusted master are allowed. 1 Accesses from an untrusted master are not allowed.

Table continues on the next page...

AIPSx_PACRn field descriptions (continued)

Field	Description
27 Reserved	This read-only field is reserved and always has the value zero.
26 SP1	<p>Supervisor protect</p> <p>Determines whether the peripheral requires supervisor privilege level for access. When this bit is set, the master privilege level must indicate the supervisor access attribute , and the MPROTn[MPL] control bit for the master must be set. If not, access terminates with an error response and no peripheral access initiates.</p> <p>0 This peripheral does not require supervisor privilege level for accesses. 1 This peripheral requires supervisor privilege level for accesses.</p>
25 WP1	<p>Write protect</p> <p>Determines whether the peripheral allows write accesses. When this bit is set and a write access is attempted, access terminates with an error response and no peripheral access initiates.</p> <p>0 This peripheral allows write accesses. 1 This peripheral is write protected.</p>
24 TP1	<p>Trusted protect</p> <p>Determines whether the peripheral allows accesses from an untrusted master. When this bit is set and an access is attempted by an untrusted master, the access terminates with an error response and no peripheral access initiates.</p> <p>0 Accesses from an untrusted master are allowed. 1 Accesses from an untrusted master are not allowed.</p>
23 Reserved	This read-only field is reserved and always has the value zero.
22 SP2	<p>Supervisor protect</p> <p>Determines whether the peripheral requires supervisor privilege level for access. When this bit is set, the master privilege level must indicate the supervisor access attribute , and the MPROTn[MPL] control bit for the master must be set. If not, access terminates with an error response and no peripheral access initiates.</p> <p>0 This peripheral does not require supervisor privilege level for accesses. 1 This peripheral requires supervisor privilege level for accesses.</p>
21 WP2	<p>Write protect</p> <p>Determines whether the peripheral allows write accesses. When this bit is set and a write access is attempted, access terminates with an error response and no peripheral access initiates.</p> <p>0 This peripheral allows write accesses. 1 This peripheral is write protected.</p>
20 TP2	<p>Trusted protect</p> <p>Determines whether the peripheral allows accesses from an untrusted master. When this bit is set and an access is attempted by an untrusted master, the access terminates with an error response and no peripheral access initiates.</p>

Table continues on the next page...

AIPSx_PACRn field descriptions (continued)

Field	Description
	<p>0 Accesses from an untrusted master are allowed.</p> <p>1 Accesses from an untrusted master are not allowed.</p>
19 Reserved	This read-only field is reserved and always has the value zero.
18 SP3	<p>Supervisor protect</p> <p>Determines whether the peripheral requires supervisor privilege level for access. When this bit is set, the master privilege level must indicate the supervisor access attribute , and the MPROTn[MPL] control bit for the master must be set. If not, access terminates with an error response and no peripheral access initiates.</p> <p>0 This peripheral does not require supervisor privilege level for accesses.</p> <p>1 This peripheral requires supervisor privilege level for accesses.</p>
17 WP3	<p>Write protect</p> <p>Determines whether the peripheral allows write accesss. When this bit is set and a write access is attempted, access terminates with an error response and no peripheral access initiates.</p> <p>0 This peripheral allows write accesses.</p> <p>1 This peripheral is write protected.</p>
16 TP3	<p>Trusted protect</p> <p>Determines whether the peripheral allows accesses from an untrusted master. When this bit is set and an access is attempted by an untrusted master, the access terminates with an error response and no peripheral access initiates.</p> <p>0 Accesses from an untrusted master are allowed.</p> <p>1 Accesses from an untrusted master are not allowed.</p>
15 Reserved	This read-only field is reserved and always has the value zero.
14 SP4	<p>Supervisor protect</p> <p>Determines whether the peripheral requires supervisor privilege level for access. When this bit is set, the master privilege level must indicate the supervisor access attribute , and the MPROTn[MPL] control bit for the master must be set. If not, access terminates with an error response and no peripheral access initiates.</p> <p>0 This peripheral does not require supervisor privilege level for accesses.</p> <p>1 This peripheral requires supervisor privilege level for accesses.</p>
13 WP4	<p>Write protect</p> <p>Determines whether the peripheral allows write accesss. When this bit is set and a write access is attempted, access terminates with an error response and no peripheral access initiates.</p> <p>0 This peripheral allows write accesses.</p> <p>1 This peripheral is write protected.</p>
12 TP4	<p>Trusted protect</p>

Table continues on the next page...

AIPSx_PACRn field descriptions (continued)

Field	Description
	<p>Determines whether the peripheral allows accesses from an untrusted master. When this bit is set and an access is attempted by an untrusted master, the access terminates with an error response and no peripheral access initiates.</p> <p>0 Accesses from an untrusted master are allowed. 1 Accesses from an untrusted master are not allowed.</p>
11 Reserved	This read-only field is reserved and always has the value zero.
10 SP5	<p>Supervisor protect</p> <p>Determines whether the peripheral requires supervisor privilege level for access. When this bit is set, the master privilege level must indicate the supervisor access attribute , and the MPROTn[MPL] control bit for the master must be set. If not, access terminates with an error response and no peripheral access initiates.</p> <p>0 This peripheral does not require supervisor privilege level for accesses. 1 This peripheral requires supervisor privilege level for accesses.</p>
9 WP5	<p>Write protect</p> <p>Determines whether the peripheral allows write accesses. When this bit is set and a write access is attempted, access terminates with an error response and no peripheral access initiates.</p> <p>0 This peripheral allows write accesses. 1 This peripheral is write protected.</p>
8 TP5	<p>Trusted protect</p> <p>Determines whether the peripheral allows accesses from an untrusted master. When this bit is set and an access is attempted by an untrusted master, the access terminates with an error response and no peripheral access initiates.</p> <p>0 Accesses from an untrusted master are allowed. 1 Accesses from an untrusted master are not allowed.</p>
7 Reserved	This read-only field is reserved and always has the value zero.
6 SP6	<p>Supervisor protect</p> <p>Determines whether the peripheral requires supervisor privilege level for access. When this bit is set, the master privilege level must indicate the supervisor access attribute , and the MPROTn[MPL] control bit for the master must be set. If not, access terminates with an error response and no peripheral access initiates.</p> <p>0 This peripheral does not require supervisor privilege level for accesses. 1 This peripheral requires supervisor privilege level for accesses.</p>
5 WP6	<p>Write protect</p> <p>Determines whether the peripheral allows write accesses. When this bit is set and a write access is attempted, access terminates with an error response and no peripheral access initiates.</p> <p>0 This peripheral allows write accesses. 1 This peripheral is write protected.</p>

Table continues on the next page...

AIPSx_PACRn field descriptions (continued)

Field	Description
4 TP6	<p>Trusted protect</p> <p>Determines whether the peripheral allows accesses from an untrusted master. When this bit is set and an access is attempted by an untrusted master, the access terminates with an error response and no peripheral access initiates .</p> <p>0 Accesses from an untrusted master are allowed. 1 Accesses from an untrusted master are not allowed.</p>
3 Reserved	This read-only field is reserved and always has the value zero.
2 SP7	<p>Supervisor protect</p> <p>Determines whether the peripheral requires supervisor privilege level for access. When this bit is set, the master privilege level must indicate the supervisor access attribute , and the MPROTn[MPL] control bit for the master must be set. If not, access terminates with an error response and no peripheral access initiates .</p> <p>0 This peripheral does not require supervisor privilege level for accesses. 1 This peripheral requires supervisor privilege level for accesses.</p>
1 WP7	<p>Write protect</p> <p>Determines whether the peripheral allows write accesss. When this bit is set and a write access is attempted, access terminates with an error response and no peripheral access initiates.</p> <p>0 This peripheral allows write accesss. 1 This peripheral is write protected.</p>
0 TP7	<p>Trusted protect</p> <p>Determines whether the peripheral allows accesses from an untrusted master. When this bit is set and an access is attempted by an untrusted master, the access terminates with an error response and no peripheral access initiates.</p> <p>0 Accesses from an untrusted master are allowed. 1 Accesses from an untrusted master are not allowed.</p>

19.2.3 Peripheral Access Control Register (AIPSx_PACRn)

Each of the peripherals has a four-bit PACR[0:127] field which defines the access levels supported by the given module. Eight PACR fields are grouped together to form a 32-bit PACR[A:P] register:

- PACRA-P define the access levels for the 128 peripherals

The peripheral assignments to each PACR register is defined by the memory map slot that the peripherals are assigned. See the device's Memory Map details for the assignments for your particular device.

NOTE

The reset value of the PACRE-P depends on your device's configuration.

Addresses: 4000_0000h base + 40h offset + (4d × n), where n = 0d to 11d

Bit	31	30	29	28	27	26	25	24	23	22	21	20	19	18	17	16	15	14	13	12	11	10	9	8	7	6	5	4	3	2	1	0
R	0				0				0				0				0				0				0				0			
W		SP0	WP0	TP0		SP1	WP1	TP1		SP2	WP2	TP2		SP3	WP3	TP3		SP4	WP4	TP4		SP5	WP5	TP5		SP6	WP6	TP6		SP7	WP7	TP7
Reset	x*	x*	x*	x*	x*	x*	x*	x*	x*	x*	x*	x*	x*	x*	x*	x*	x*	x*	x*	x*	x*	x*	x*	x*	x*	x*	x*	x*	x*	x*	x*	

* Notes:

- x = Undefined at reset.

AIPSx_PACRn field descriptions

Field	Description
31 Reserved	This read-only field is reserved and always has the value zero.
30 SP0	Supervisor protect Determines whether the peripheral requires supervisor privilege level for access. When this bit is set, the master privilege level must indicate the supervisor access attribute , and the MPROTn[MPL] control bit for the master must be set. If not, access terminates with an error response and no peripheral access initiates. 0 This peripheral does not require supervisor privilege level for accesses. 1 This peripheral requires supervisor privilege level for accesses.
29 WP0	Write protect Determines whether the peripheral allows write accesses. When this bit is set and a write access is attempted, access terminates with an error response and no peripheral access initiates. 0 This peripheral allows write accesses. 1 This peripheral is write protected.
28 TP0	Trusted protect Determines whether the peripheral allows accesses from an untrusted master. When this bit is set and an access is attempted by an untrusted master, the access terminates with an error response and no peripheral access initiates. 0 Accesses from an untrusted master are allowed. 1 Accesses from an untrusted master are not allowed.
27 Reserved	This read-only field is reserved and always has the value zero.
26 SP1	Supervisor protect Determines whether the peripheral requires supervisor privilege level for access. When this bit is set, the master privilege level must indicate the supervisor access attribute , and the MPROTn[MPL] control bit for the master must be set. If not, access terminates with an error response and no peripheral access initiates.

Table continues on the next page...

AIPStx_PACRn field descriptions (continued)

Field	Description
	<p>0 This peripheral does not require supervisor privilege level for accesses.</p> <p>1 This peripheral requires supervisor privilege level for accesses.</p>
25 WP1	<p>Write protect</p> <p>Determines whether the peripheral allows write access. When this bit is set and a write access is attempted, access terminates with an error response and no peripheral access initiates.</p> <p>0 This peripheral allows write accesses.</p> <p>1 This peripheral is write protected.</p>
24 TP1	<p>Trusted protect</p> <p>Determines whether the peripheral allows accesses from an untrusted master. When this bit is set and an access is attempted by an untrusted master, the access terminates with an error response and no peripheral access initiates.</p> <p>0 Accesses from an untrusted master are allowed.</p> <p>1 Accesses from an untrusted master are not allowed.</p>
23 Reserved	<p>This read-only field is reserved and always has the value zero.</p>
22 SP2	<p>Supervisor protect</p> <p>Determines whether the peripheral requires supervisor privilege level for access. When this bit is set, the master privilege level must indicate the supervisor access attribute , and the MPROTn[MPL] control bit for the master must be set. If not, access terminates with an error response and no peripheral access initiates.</p> <p>0 This peripheral does not require supervisor privilege level for accesses.</p> <p>1 This peripheral requires supervisor privilege level for accesses.</p>
21 WP2	<p>Write protect</p> <p>Determines whether the peripheral allows write access. When this bit is set and a write access is attempted, access terminates with an error response and no peripheral access initiates.</p> <p>0 This peripheral allows write accesses.</p> <p>1 This peripheral is write protected.</p>
20 TP2	<p>Trusted protect</p> <p>Determines whether the peripheral allows accesses from an untrusted master. When this bit is set and an access is attempted by an untrusted master, the access terminates with an error response and no peripheral access initiates.</p> <p>0 Accesses from an untrusted master are allowed.</p> <p>1 Accesses from an untrusted master are not allowed.</p>
19 Reserved	<p>This read-only field is reserved and always has the value zero.</p>
18 SP3	<p>Supervisor protect</p> <p>Determines whether the peripheral requires supervisor privilege level for access. When this bit is set, the master privilege level must indicate the supervisor access attribute , and the MPROTn[MPL] control bit for</p>

Table continues on the next page...

AIPSx_PACRn field descriptions (continued)

Field	Description
	<p>the master must be set. If not, access terminates with an error response and no peripheral access initiates.</p> <p>0 This peripheral does not require supervisor privilege level for accesses. 1 This peripheral requires supervisor privilege level for accesses.</p>
17 WP3	<p>Write protect</p> <p>Determines whether the peripheral allows write access. When this bit is set and a write access is attempted, access terminates with an error response and no peripheral access initiates.</p> <p>0 This peripheral allows write accesses. 1 This peripheral is write protected.</p>
16 TP3	<p>Trusted protect</p> <p>Determines whether the peripheral allows accesses from an untrusted master. When this bit is set and an access is attempted by an untrusted master, the access terminates with an error response and no peripheral access initiates.</p> <p>0 Accesses from an untrusted master are allowed. 1 Accesses from an untrusted master are not allowed.</p>
15 Reserved	<p>This read-only field is reserved and always has the value zero.</p>
14 SP4	<p>Supervisor protect</p> <p>Determines whether the peripheral requires supervisor privilege level for access. When this bit is set, the master privilege level must indicate the supervisor access attribute, and the MPROTn[MPL] control bit for the master must be set. If not, access terminates with an error response and no peripheral access initiates.</p> <p>0 This peripheral does not require supervisor privilege level for accesses. 1 This peripheral requires supervisor privilege level for accesses.</p>
13 WP4	<p>Write protect</p> <p>Determines whether the peripheral allows write access. When this bit is set and a write access is attempted, access terminates with an error response and no peripheral access initiates.</p> <p>0 This peripheral allows write accesses. 1 This peripheral is write protected.</p>
12 TP4	<p>Trusted protect</p> <p>Determines whether the peripheral allows accesses from an untrusted master. When this bit is set and an access is attempted by an untrusted master, the access terminates with an error response and no peripheral access initiates.</p> <p>0 Accesses from an untrusted master are allowed. 1 Accesses from an untrusted master are not allowed.</p>
11 Reserved	<p>This read-only field is reserved and always has the value zero.</p>
10 SP5	<p>Supervisor protect</p>

Table continues on the next page...

AIPSx_PACRn field descriptions (continued)

Field	Description
	<p>Determines whether the peripheral requires supervisor privilege level for access. When this bit is set, the master privilege level must indicate the supervisor access attribute , and the MPROTn[MPL] control bit for the master must be set. If not, access terminates with an error response and no peripheral access initiates.</p> <p>0 This peripheral does not require supervisor privilege level for accesses. 1 This peripheral requires supervisor privilege level for accesses.</p>
9 WP5	<p>Write protect</p> <p>Determines whether the peripheral allows write access. When this bit is set and a write access is attempted, access terminates with an error response and no peripheral access initiates.</p> <p>0 This peripheral allows write accesses. 1 This peripheral is write protected.</p>
8 TP5	<p>Trusted protect</p> <p>Determines whether the peripheral allows accesses from an untrusted master. When this bit is set and an access is attempted by an untrusted master, the access terminates with an error response and no peripheral access initiates.</p> <p>0 Accesses from an untrusted master are allowed. 1 Accesses from an untrusted master are not allowed.</p>
7 Reserved	<p>This read-only field is reserved and always has the value zero.</p>
6 SP6	<p>Supervisor protect</p> <p>Determines whether the peripheral requires supervisor privilege level for access. When this bit is set, the master privilege level must indicate the supervisor access attribute , and the MPROTn[MPL] control bit for the master must be set. If not, access terminates with an error response and no peripheral access initiates.</p> <p>0 This peripheral does not require supervisor privilege level for accesses. 1 This peripheral requires supervisor privilege level for accesses.</p>
5 WP6	<p>Write protect</p> <p>Determines whether the peripheral allows write access. When this bit is set and a write access is attempted, access terminates with an error response and no peripheral access initiates.</p> <p>0 This peripheral allows write accesses. 1 This peripheral is write protected.</p>
4 TP6	<p>Trusted protect</p> <p>Determines whether the peripheral allows accesses from an untrusted master. When this bit is set and an access is attempted by an untrusted master, the access terminates with an error response and no peripheral access initiates .</p> <p>0 Accesses from an untrusted master are allowed. 1 Accesses from an untrusted master are not allowed.</p>
3 Reserved	<p>This read-only field is reserved and always has the value zero.</p>

Table continues on the next page...

AIPSx_PACRn field descriptions (continued)

Field	Description
2 SP7	<p>Supervisor protect</p> <p>Determines whether the peripheral requires supervisor privilege level for access. When this bit is set, the master privilege level must indicate the supervisor access attribute , and the MPROTn[MPL] control bit for the master must be set. If not, access terminates with an error response and no peripheral access initiates .</p> <p>0 This peripheral does not require supervisor privilege level for accesses. 1 This peripheral requires supervisor privilege level for accesses.</p>
1 WP7	<p>Write protect</p> <p>Determines whether the peripheral allows write accesss. When this bit is set and a write access is attempted, access terminates with an error response and no peripheral access initiates.</p> <p>0 This peripheral allows write accesss. 1 This peripheral is write protected.</p>
0 TP7	<p>Trusted protect</p> <p>Determines whether the peripheral allows accesss from an untrusted master. When this bit is set and an access is attempted by an untrusted master, the access terminates with an error response and no peripheral access initiates.</p> <p>0 Accesss from an untrusted master are allowed. 1 Accesss from an untrusted master are not allowed.</p>

19.3 Functional Description

The peripheral bridge serves as an interface between the crossbar switch and the slave peripheral bus. It functions as a protocol translator.

Accesses which fall within the address space of the peripheral bridge are decoded to provide individual module selects for peripheral devices on the slave bus interface.

19.3.1 Access support

Aligned and misaligned 32-bit and 16-bit accesss, as well as byte accesss are supported for 32-bit peripherals. Misaligned accesss are supported to allow memory to be placed on the slave peripheral bus. Peripheral registers must not be misaligned, although no explicit checking is performed by the peripheral bridge. All accesss are performed with a single transfer.

All accesss to the peripheral slots must be sized less than or equal to the designated peripheral slot size. If an access is attempted which is larger (in size) than the targeted port, an error response is generated.



Chapter 20

Direct memory access multiplexer (DMAMUX)

20.1 Introduction

NOTE

For the chip-specific implementation details of this module's instances see the chip configuration chapter.

20.1.1 Overview

The DMA Mux routes up to 63 DMA sources (called slots) to be mapped to any of the 16 DMA channels. This is illustrated in the following figure.

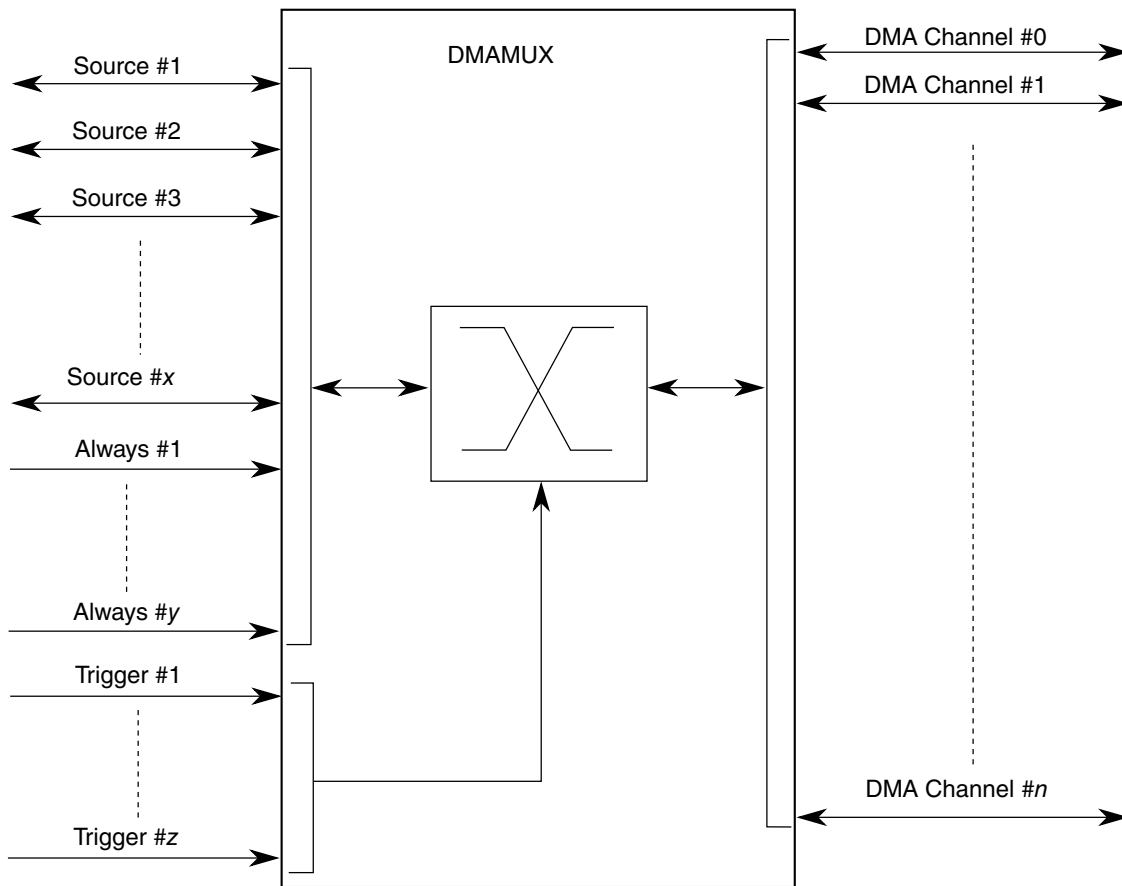

Figure 20-1. DMA MUX block diagram

20.1.2 Features

The DMA channel MUX provides these features:

- 52 peripheral slots + 10 always-on slots can be routed to 16 channels.
- 16 independently selectable DMA channel routers.
 - The first 4 channels additionally provide a trigger functionality.
- Each channel router can be assigned to one of the 52 possible peripheral DMA slots or to one of the 10 always-on slots.

20.1.3 Modes of operation

The following operating modes are available:

- Disabled mode

In this mode, the DMA channel is disabled. Since disabling and enabling of DMA channels is done primarily via the DMA configuration registers, this mode is used mainly as the reset state for a DMA channel in the DMA channel MUX. It may also be used to temporarily suspend a DMA channel while reconfiguration of the system takes place (e.g. changing the period of a DMA trigger).

- Normal mode

In this mode, a DMA source (such as DSPI transmit or DSPI receive) is routed directly to the specified DMA channel. The operation of the DMA MUX in this mode is completely transparent to the system.

- Periodic trigger mode

In this mode, a DMA source may only request a DMA transfer (such as when a transmit buffer becomes empty or a receive buffer becomes full) periodically. Configuration of the period is done in the registers of the periodic interrupt timer (PIT). This mode is only available for channels 0-3.

20.2 External signal description

The DMA MUX has no external pins.

20.3 Memory map/register definition

This section provides a detailed description of all memory-mapped registers in the DMA MUX.

The following table shows the memory map for the DMA MUX.

All registers are accessible via 8-bit, 16-bit or 32-bit accesses. However, 16-bit accesses must be aligned to 16-bit boundaries, and 32-bit accesses must be aligned to 32-bit boundaries. As an example, CHCFG0 through CHCFG3 are accessible by a 32-bit read/write to address 'base + 0x00', but performing a 32-bit access to address 'base + 0x01' is illegal.

DMAMUX memory map

Absolute address (hex)	Register name	Width (in bits)	Access	Reset value	Section/page
4002_1000	Channel Configuration Register (DMAMUX_CHCFG0)	8	R/W	00h	20.3.1/402
4002_1001	Channel Configuration Register (DMAMUX_CHCFG1)	8	R/W	00h	20.3.1/402
4002_1002	Channel Configuration Register (DMAMUX_CHCFG2)	8	R/W	00h	20.3.1/402
4002_1003	Channel Configuration Register (DMAMUX_CHCFG3)	8	R/W	00h	20.3.1/402
4002_1004	Channel Configuration Register (DMAMUX_CHCFG4)	8	R/W	00h	20.3.1/402
4002_1005	Channel Configuration Register (DMAMUX_CHCFG5)	8	R/W	00h	20.3.1/402
4002_1006	Channel Configuration Register (DMAMUX_CHCFG6)	8	R/W	00h	20.3.1/402
4002_1007	Channel Configuration Register (DMAMUX_CHCFG7)	8	R/W	00h	20.3.1/402
4002_1008	Channel Configuration Register (DMAMUX_CHCFG8)	8	R/W	00h	20.3.1/402
4002_1009	Channel Configuration Register (DMAMUX_CHCFG9)	8	R/W	00h	20.3.1/402
4002_100A	Channel Configuration Register (DMAMUX_CHCFG10)	8	R/W	00h	20.3.1/402
4002_100B	Channel Configuration Register (DMAMUX_CHCFG11)	8	R/W	00h	20.3.1/402
4002_100C	Channel Configuration Register (DMAMUX_CHCFG12)	8	R/W	00h	20.3.1/402
4002_100D	Channel Configuration Register (DMAMUX_CHCFG13)	8	R/W	00h	20.3.1/402
4002_100E	Channel Configuration Register (DMAMUX_CHCFG14)	8	R/W	00h	20.3.1/402
4002_100F	Channel Configuration Register (DMAMUX_CHCFG15)	8	R/W	00h	20.3.1/402

20.3.1 Channel Configuration Register (DMAMUX_CHCFGn)

Each of the DMA channels can be independently enabled/disabled and associated with one of the DMA slots (peripheral slots or always-on slots) in the system.

NOTE

Setting multiple CHCFG registers with the same Source value will result in unpredictable behavior.

NOTE

Before changing the trigger or source settings a DMA channel must be disabled via the CHCFGn[ENBL] bit.

Addresses: 4002_1000h base + 0h offset + (1d × n), where n = 0d to 15d

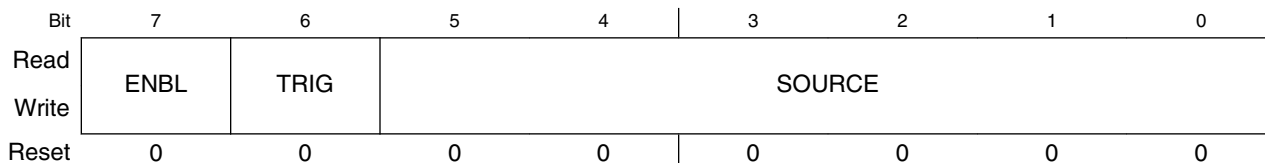

DMAMUX_CHCFGn field descriptions

Field	Description
7 ENBL	DMA Channel Enable Enables the DMA channel 0 DMA channel is disabled. This mode is primarily used during configuration of the DMA Mux. The DMA has separate channel enables/disables, which should be used to disable or re-configure a DMA channel. 1 DMA channel is enabled
6 TRIG	DMA Channel Trigger Enable Enables the periodic trigger capability for the triggered DMA channel 0 Triggering is disabled. If triggering is disabled, and the ENBL bit is set, the DMA Channel will simply route the specified source to the DMA channel. (normal mode) 1 Triggering is enabled. If triggering is enabled, and the ENBL bit is set, the DMAMUX is in periodic trigger mode.
5-0 SOURCE	DMA Channel Source (slot) Specifies which DMA source, if any, is routed to a particular DMA channel. Please check your device's Chip Configuration details for further details about the peripherals and their slot numbers.

20.4 Functional description

This section provides the functional description of the DMA MUX.

The primary purpose of the DMA MUX is to provide flexibility in the system's use of the available DMA channels. As such, configuration of the DMA MUX is intended to be a static procedure done during execution of the system boot code. However, if the procedure outlined in [Enabling and configuring sources](#) is followed, the configuration of the DMA MUX may be changed during the normal operation of the system.

Functionally, the DMA MUX channels may be divided into two classes: Channels, which implement the normal routing functionality plus periodic triggering capability, and channels, which implement only the normal routing functionality.

20.4.1 DMA channels with periodic triggering capability

Besides the normal routing functionality, the first four channels of the DMA MUX provide a special periodic triggering capability that can be used to provide an automatic mechanism to transmit bytes, frames or packets at fixed intervals without the need for processor intervention. The trigger is generated by the periodic interrupt timer (PIT); as

such, the configuration of the periodic triggering interval is done via configuration registers in the PIT. Please refer to Periodic Interrupt Timer chapter for more information on this topic.

Note

Because of the dynamic nature of the system (i.e. DMA channel priorities, bus arbitration, interrupt service routine lengths, etc.), the number of clock cycles between a trigger and the actual DMA transfer cannot be guaranteed.

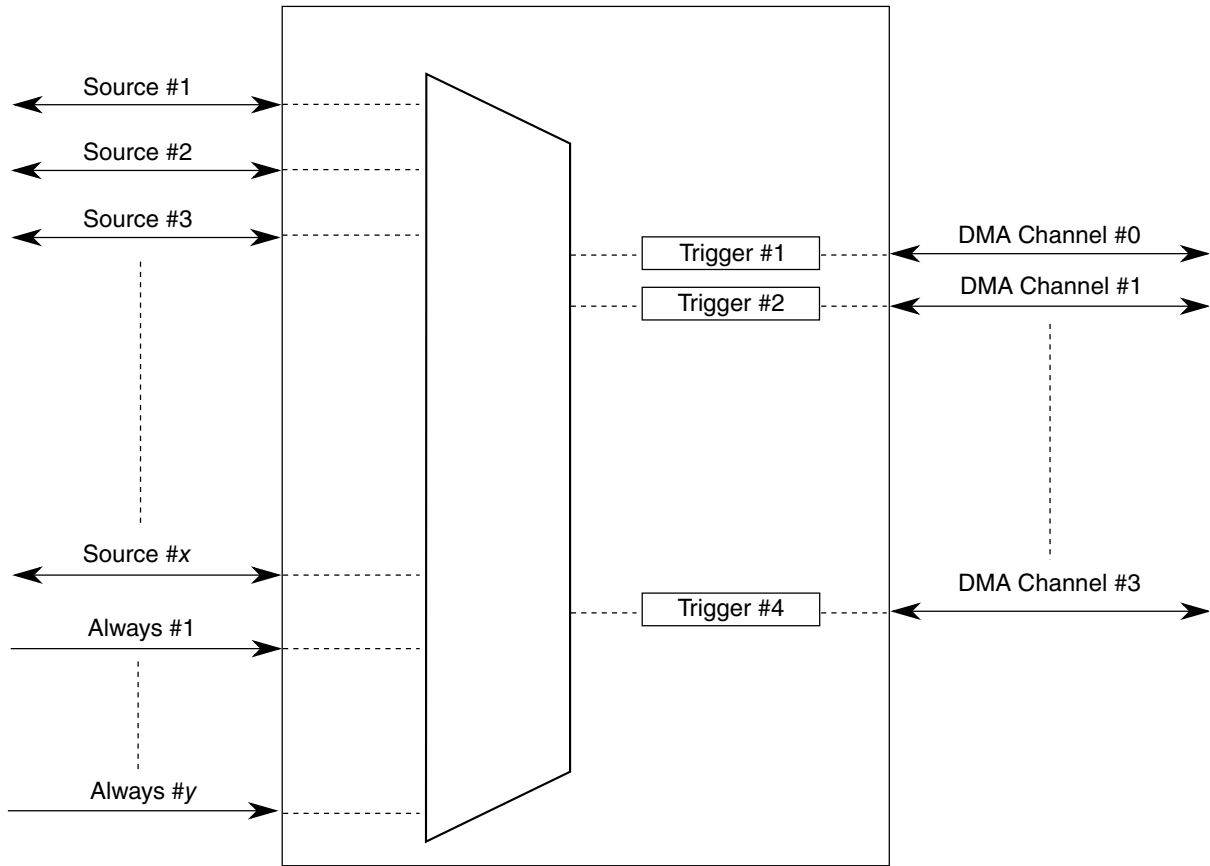

Figure 20-19. DMA MUX triggered channels

The DMA channel triggering capability allows the system to "schedule" regular DMA transfers, usually on the transmit side of certain peripherals, without the intervention of the processor. This trigger works by gating the request from the peripheral to the DMA until a trigger event has been seen. This is illustrated in the following figure.

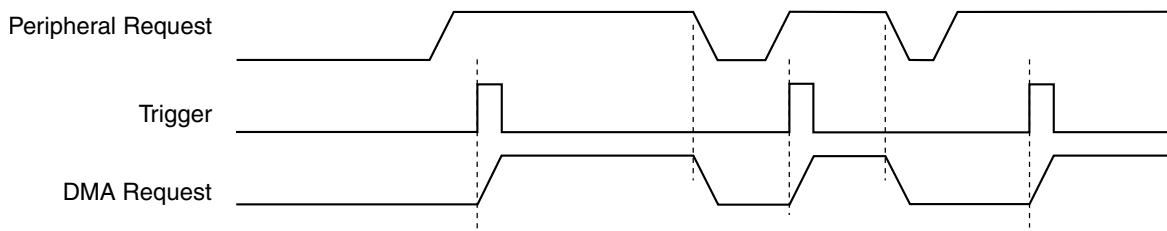

Figure 20-20. DMA MUX channel triggering: normal operation

Once the DMA request has been serviced, the peripheral will negate its request, effectively resetting the gating mechanism until the peripheral re-asserts its request AND the next trigger event is seen. This means that if a trigger is seen, but the peripheral is not requesting a transfer, that triggered will be ignored. This situation is illustrated in the following figure.

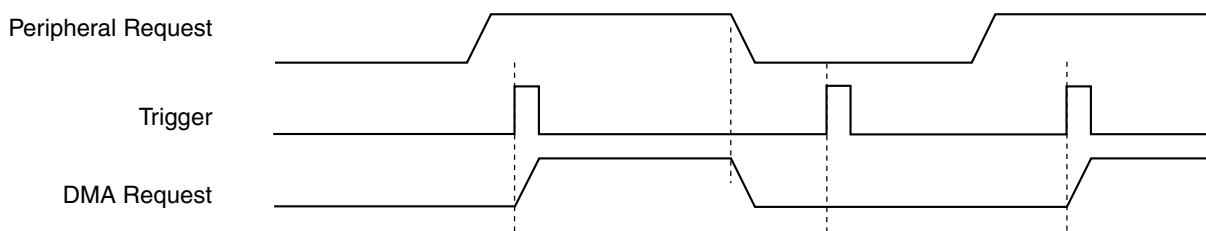

Figure 20-21. DMA MUX channel triggering: ignored trigger

This triggering capability may be used with any peripheral that supports DMA transfers, and is most useful for two types of situations:

- Periodically polling external devices on a particular bus. As an example, the transmit side of an SPI is assigned to a DMA channel with a trigger, as described above. Once setup, the SPI will request DMA transfers (presumably from memory) as long as its transmit buffer is empty. By using a trigger on this channel, the SPI transfers can be automatically performed every 5 μ s (as an example). On the receive side of the SPI, the SPI and DMA can be configured to transfer receive data into memory, effectively implementing a method to periodically read data from external devices and transfer the results into memory without processor intervention.
- Using the GPIO ports to drive or sample waveforms. By configuring the DMA to transfer data to one or more GPIO ports, it is possible to create complex waveforms using tabular data stored in on-chip memory. Conversely, using the DMA to periodically transfer data from one or more GPIO ports, it is possible to sample complex waveforms and store the results in tabular form in on-chip memory.

A more detailed description of the capability of each trigger (which includes resolution, range of values, etc.) may be found in the Periodic Interrupt Timer chapter.

20.4.2 DMA channels with no triggering capability

The other channels of the DMA MUX provide the normal routing functionality as described in [Modes of operation](#).

20.4.3 "Always enabled" DMA sources

In addition to the peripherals that can be used as DMA sources, there are 10 additional DMA sources that are "always enabled". Unlike the peripheral DMA sources, where the peripheral controls the flow of data during DMA transfers, the "always enabled" sources provide no such "throttling" of the data transfers. These sources are most useful in the following cases:

- Doing DMA transfers to/from GPIO—Moving data from/to one or more GPIO pins, either un-throttled (that is as fast as possible), or periodically (using the DMA triggering capability).
- Doing DMA transfers from memory to memory—Moving data from memory to memory, typically as fast as possible, sometimes with software activation.
- Doing DMA transfers from memory to the external bus (or vice-versa)—Similar to memory to memory transfers, this is typically done as quickly as possible.
- Any DMA transfer that requires software activation—Any DMA transfer that should be explicitly started by software.

In cases where software should initiate the start of a DMA transfer, an "always enabled" DMA source can be used to provide maximum flexibility. When activating a DMA channel via software, subsequent executions of the minor loop require a new "start" event be sent. This can either be a new software activation, or a transfer request from the DMA channel MUX. The options for doing this are:

- Transfer all data in a single minor loop. By configuring the DMA to transfer all of the data in a single minor loop (that is major loop counter = 1), no re-activation of the channel is necessary. The disadvantage to this option is the reduced granularity in determining the load that the DMA transfer will incur on the system. For this option, the DMA channel should be disabled in the DMA channel MUX.

- Use explicit software re-activation. In this option, the DMA is configured to transfer the data using both minor and major loops, but the processor is required to re-activate the channel (by writing to the DMA registers) *after every minor loop*. For this option, the DMA channel should be disabled in the DMA channel MUX.
- Use a "always enabled" DMA source. In this option, the DMA is configured to transfer the data using both minor and major loops, and the DMA channel MUX does the channel re-activation. For this option, the DMA channel should be enabled and pointing to an "always enabled" source. Note that the re-activation of the channel can be continuous (DMA triggering is disabled) or can use the DMA triggering capability. In this manner, it is possible to execute periodic transfers of packets of data from one source to another, without processor intervention.

20.5 Initialization/application information

This section provides instructions for initializing the DMA channel MUX.

20.5.1 Reset

The reset state of each individual bit is shown in [Memory map/register definition](#). In summary, after reset, all channels are disabled and must be explicitly enabled before use.

20.5.2 Enabling and configuring sources

Enabling a source with periodic triggering

1. Determine with which DMA channel the source will be associated. Note that only the first 4 DMA channels have periodic triggering capability
2. Clear the CHCFG[ENBL] and CHCFG[TRIG] bits of the DMA channel
3. Ensure that the DMA channel is properly configured in the DMA. The DMA channel may be enabled at this point
4. Configure the corresponding timer
5. Select the source to be routed to the DMA channel. Write to the corresponding CHCFG register, ensuring that the CHCFG[ENBL] and CHCFG[TRIG] bits are set

Configure source #5 transmit for use with DMA channel 2, with periodic triggering capability

1. Write 0x00 to CHCFG2 (base address + 0x02)
2. Configure channel 2 in the DMA, including enabling the channel

3. Configure a timer for the desired trigger interval
4. Write 0xC5 to CHCFG2 (base address + 0x02)

The following code example illustrates steps #1 and #4 above:

```
In File registers.h:
#define DMAMUX_BASE_ADDR      0xFC084000/* Example only ! */
/* Following example assumes char is 8-bits */
volatile unsigned char *CHCONFIG0 = (volatile unsigned char *) (DMAMUX_BASE_ADDR+0x0000);
volatile unsigned char *CHCONFIG1 = (volatile unsigned char *) (DMAMUX_BASE_ADDR+0x0001);
volatile unsigned char *CHCONFIG2 = (volatile unsigned char *) (DMAMUX_BASE_ADDR+0x0002);
volatile unsigned char *CHCONFIG3 = (volatile unsigned char *) (DMAMUX_BASE_ADDR+0x0003);
volatile unsigned char *CHCONFIG4 = (volatile unsigned char *) (DMAMUX_BASE_ADDR+0x0004);
volatile unsigned char *CHCONFIG5 = (volatile unsigned char *) (DMAMUX_BASE_ADDR+0x0005);
volatile unsigned char *CHCONFIG6 = (volatile unsigned char *) (DMAMUX_BASE_ADDR+0x0006);
volatile unsigned char *CHCONFIG7 = (volatile unsigned char *) (DMAMUX_BASE_ADDR+0x0007);
volatile unsigned char *CHCONFIG8 = (volatile unsigned char *) (DMAMUX_BASE_ADDR+0x0008);
volatile unsigned char *CHCONFIG9 = (volatile unsigned char *) (DMAMUX_BASE_ADDR+0x0009);
volatile unsigned char *CHCONFIG10= (volatile unsigned char *) (DMAMUX_BASE_ADDR+0x000A);
volatile unsigned char *CHCONFIG11= (volatile unsigned char *) (DMAMUX_BASE_ADDR+0x000B);
volatile unsigned char *CHCONFIG12= (volatile unsigned char *) (DMAMUX_BASE_ADDR+0x000C);
volatile unsigned char *CHCONFIG13= (volatile unsigned char *) (DMAMUX_BASE_ADDR+0x000D);
volatile unsigned char *CHCONFIG14= (volatile unsigned char *) (DMAMUX_BASE_ADDR+0x000E);
volatile unsigned char *CHCONFIG15= (volatile unsigned char *) (DMAMUX_BASE_ADDR+0x000F);

In File main.c:
#include "registers.h"
:
:
*CHCONFIG2 = 0x00;
*CHCONFIG2 = 0xC5;
```

Enabling a source without periodic triggering

1. Determine with which DMA channel the source will be associated. Note that only the first 4 DMA channels have periodic triggering capability
2. Clear the CHCFG[ENBL] and CHCFG[TRIG] bits of the DMA channel
3. Ensure that the DMA channel is properly configured in the DMA. The DMA channel may be enabled at this point
4. Select the source to be routed to the DMA channel. Write to the corresponding CHCFG register, ensuring that the CHCFG[ENBL] is set while the CHCFG[TRIG] bit is cleared

Configure source #5 Transmit for use with DMA channel 2, with no periodic triggering capability.

1. Write 0x00 to CHCFG2 (base address + 0x02)
2. Configure channel 2 in the DMA, including enabling the channel
3. Write 0x85 to CHCFG2 (base address + 0x02)

The following code example illustrates steps #1 and #3 above:

```
In File registers.h:
#define DMAMUX_BASE_ADDR      0xFC084000/* Example only ! */
/* Following example assumes char is 8-bits */
volatile unsigned char *CHCONFIG0 = (volatile unsigned char *) (DMAMUX_BASE_ADDR+0x0000);
volatile unsigned char *CHCONFIG1 = (volatile unsigned char *) (DMAMUX_BASE_ADDR+0x0001);
volatile unsigned char *CHCONFIG2 = (volatile unsigned char *) (DMAMUX_BASE_ADDR+0x0002);
```



```
volatile unsigned char *CHCONFIG3 = (volatile unsigned char *) (DMAMUX_BASE_ADDR+0x0003);
volatile unsigned char *CHCONFIG4 = (volatile unsigned char *) (DMAMUX_BASE_ADDR+0x0004);
volatile unsigned char *CHCONFIG5 = (volatile unsigned char *) (DMAMUX_BASE_ADDR+0x0005);
volatile unsigned char *CHCONFIG6 = (volatile unsigned char *) (DMAMUX_BASE_ADDR+0x0006);
volatile unsigned char *CHCONFIG7 = (volatile unsigned char *) (DMAMUX_BASE_ADDR+0x0007);
volatile unsigned char *CHCONFIG8 = (volatile unsigned char *) (DMAMUX_BASE_ADDR+0x0008);
volatile unsigned char *CHCONFIG9 = (volatile unsigned char *) (DMAMUX_BASE_ADDR+0x0009);
volatile unsigned char *CHCONFIG10= (volatile unsigned char *) (DMAMUX_BASE_ADDR+0x000A);
volatile unsigned char *CHCONFIG11= (volatile unsigned char *) (DMAMUX_BASE_ADDR+0x000B);
volatile unsigned char *CHCONFIG12= (volatile unsigned char *) (DMAMUX_BASE_ADDR+0x000C);
volatile unsigned char *CHCONFIG13= (volatile unsigned char *) (DMAMUX_BASE_ADDR+0x000D);
volatile unsigned char *CHCONFIG14= (volatile unsigned char *) (DMAMUX_BASE_ADDR+0x000E);
volatile unsigned char *CHCONFIG15= (volatile unsigned char *) (DMAMUX_BASE_ADDR+0x000F);
```

```
In File main.c:
#include "registers.h"
:
:
*CHCONFIG2 = 0x00;
*CHCONFIG2 = 0x85;
```

Disabling a source

A particular DMA source may be disabled by not writing the corresponding source value into any of the CHCFG registers. Additionally, some module specific configuration may be necessary. Please refer to the appropriate section for more details.

Switching the source of a DMA channel

1. Disable the DMA channel in the DMA and re-configure the channel for the new source
2. Clear the CHCFG[ENBL] and CHCFG[TRIG] bits of the DMA channel
3. Select the source to be routed to the DMA channel. Write to the corresponding CHCFG register, ensuring that the CHCFG[ENBL] and CHCFG[TRIG] bits are set

Switch DMA channel 8 from source #5 transmit to source #7 transmit

1. In the DMA configuration registers, disable DMA channel 8 and re-configure it to handle the transfers to peripheral slot 7. This example assumes channel 8 doesn't have triggering capability
2. Write 0x00 to CHCFG8 (base address + 0x08)
3. Write 0x87 to CHCFG8 (base address + 0x08). (In this example, setting the CHCFG[TRIG] bit would have no effect, due to the assumption that channels 8 does not support the periodic triggering functionality).

The following code example illustrates steps #2 and #3 above:

```
In File registers.h:
#define DMAMUX_BASE_ADDR      0xFC084000/* Example only ! */
/* Following example assumes char is 8-bits */
volatile unsigned char *CHCONFIG0 = (volatile unsigned char *) (DMAMUX_BASE_ADDR+0x0000);
volatile unsigned char *CHCONFIG1 = (volatile unsigned char *) (DMAMUX_BASE_ADDR+0x0001);
volatile unsigned char *CHCONFIG2 = (volatile unsigned char *) (DMAMUX_BASE_ADDR+0x0002);
volatile unsigned char *CHCONFIG3 = (volatile unsigned char *) (DMAMUX_BASE_ADDR+0x0003);
volatile unsigned char *CHCONFIG4 = (volatile unsigned char *) (DMAMUX_BASE_ADDR+0x0004);
volatile unsigned char *CHCONFIG5 = (volatile unsigned char *) (DMAMUX_BASE_ADDR+0x0005);
volatile unsigned char *CHCONFIG6 = (volatile unsigned char *) (DMAMUX_BASE_ADDR+0x0006);
volatile unsigned char *CHCONFIG7 = (volatile unsigned char *) (DMAMUX_BASE_ADDR+0x0007);
```

Initialization/application information

```
volatile unsigned char *CHCONFIG8 = (volatile unsigned char *) (DMAMUX_BASE_ADDR+0x0008);
volatile unsigned char *CHCONFIG9 = (volatile unsigned char *) (DMAMUX_BASE_ADDR+0x0009);
volatile unsigned char *CHCONFIG10= (volatile unsigned char *) (DMAMUX_BASE_ADDR+0x000A);
volatile unsigned char *CHCONFIG11= (volatile unsigned char *) (DMAMUX_BASE_ADDR+0x000B);
volatile unsigned char *CHCONFIG12= (volatile unsigned char *) (DMAMUX_BASE_ADDR+0x000C);
volatile unsigned char *CHCONFIG13= (volatile unsigned char *) (DMAMUX_BASE_ADDR+0x000D);
volatile unsigned char *CHCONFIG14= (volatile unsigned char *) (DMAMUX_BASE_ADDR+0x000E);
volatile unsigned char *CHCONFIG15= (volatile unsigned char *) (DMAMUX_BASE_ADDR+0x000F);
```

```
In File main.c:
#include "registers.h"
:
:
*CHCONFIG8 = 0x00;
*CHCONFIG8 = 0x87;
```

Chapter 21

Direct Memory Access Controller (eDMA)

21.1 Introduction

NOTE

For the chip-specific implementation details of this module's instances see the chip configuration chapter.

The enhanced direct memory access (eDMA) controller is a second-generation module capable of performing complex data transfers with minimal intervention from a host processor. The hardware microarchitecture includes:

- A DMA engine that performs:
 - Source- and destination-address calculations
 - Data-movement operations
- Local memory containing transfer control descriptors for each of the 16 channels

21.1.1 Block diagram

This diagram illustrates the eDMA module.

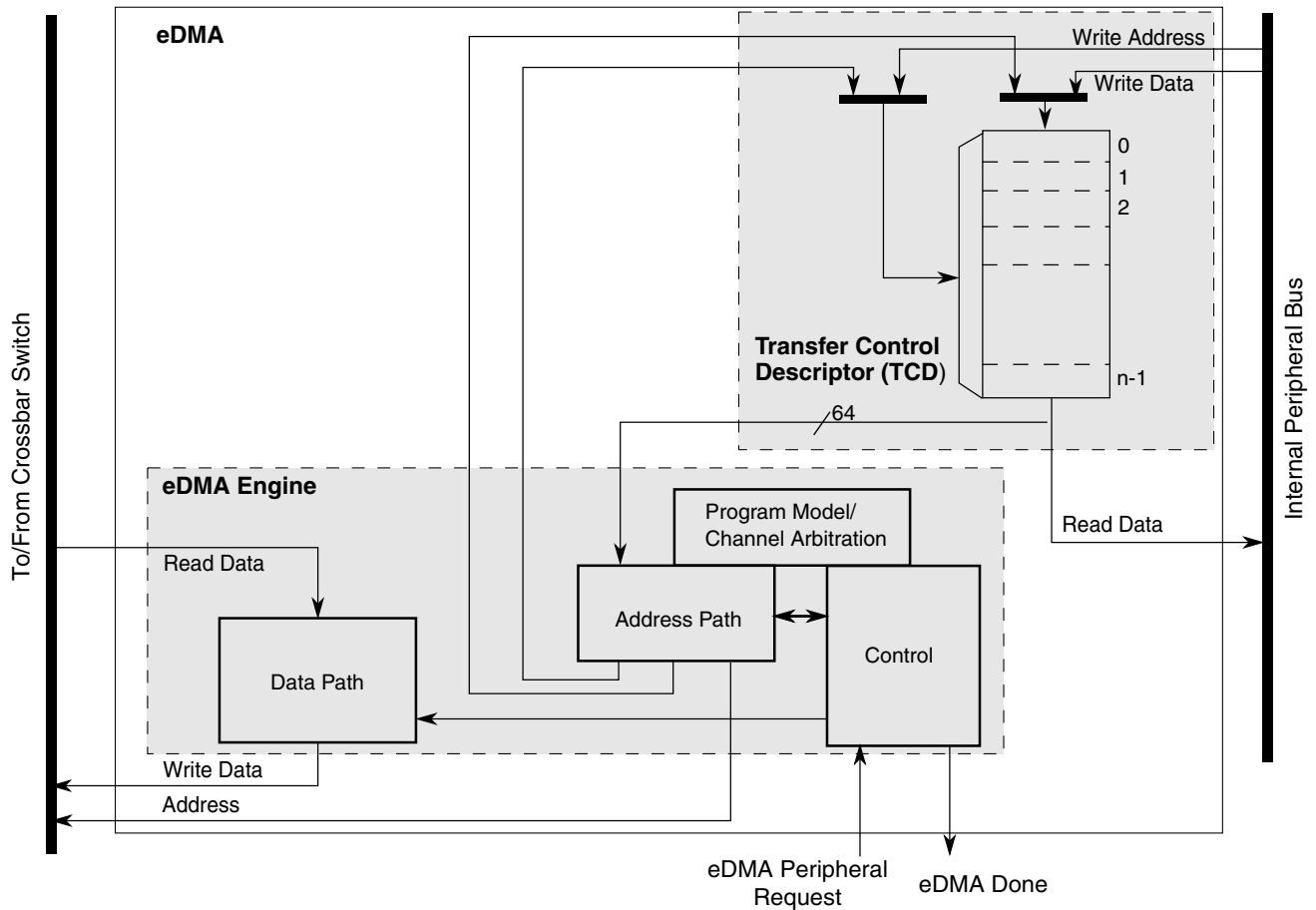

Figure 21-1. eDMA block diagram

21.1.2 Block parts

The eDMA module is partitioned into two major modules: the eDMA engine and the transfer-control descriptor local memory.

The eDMA engine is further partitioned into four submodules:

Table 21-1. eDMA engine submodules

Submodule	Function
Address path	<p>This block implements registered versions of two channel transfer control descriptors, channel x and channel y, and manages all master bus-address calculations. All the channels provide the same functionality. This structure allows data transfers associated with one channel to be preempted after the completion of a read/write sequence if a higher priority channel activation is asserted while the first channel is active. After a channel is activated, it runs until the minor loop is completed, unless preempted by a higher priority channel. This provides a mechanism (enabled by DCHPRI_n[ECP]) where a large data move operation can be preempted to minimize the time another channel is blocked from execution.</p> <p>When any channel is selected to execute, the contents of its TCD are read from local memory and loaded into the address path channel x registers for a normal start and into channel y registers for a preemption start. After the minor loop completes execution, the address path hardware writes the new values for the TCD_n{SADDR, DADDR, CITER} back to local memory. If the major iteration count is exhausted, additional processing is performed, including the final address pointer updates, reloading the TCD_n_CITER field, and a possible fetch of the next TCD_n from memory as part of a scatter/gather operation.</p>
Data path	<p>This block implements the bus master read/write datapath. It includes 16 bytes of register storage and the necessary multiplex logic to support any required data alignment. The internal read data bus is the primary input, and the internal write data bus is the primary output.</p> <p>The address and data path modules directly support the 2-stage pipelined internal bus. The address path module represents the 1st stage of the bus pipeline (address phase), while the data path module implements the 2nd stage of the pipeline (data phase).</p>
Program model/channel arbitration	<p>This block implements the first section of the eDMA programming model as well as the channel arbitration logic. The programming model registers are connected to the internal peripheral bus. The eDMA peripheral request inputs and interrupt request outputs are also connected to this block (via control logic).</p>
Control	<p>This block provides all the control functions for the eDMA engine. For data transfers where the source and destination sizes are equal, the eDMA engine performs a series of source read/destination write operations until the number of bytes specified in the minor loop byte count has moved. For descriptors where the sizes are not equal, multiple accesses of the smaller size data are required for each reference of the larger size. As an example, if the source size references 16-bit data and the destination is 32-bit data, two reads are performed, then one 32-bit write.</p>

The transfer-control descriptor local memory is further partitioned into:

Table 21-2. Transfer control descriptor memory

Submodule	Description
Memory controller	This logic implements the required dual-ported controller, managing accesses from the eDMA engine as well as references from the internal peripheral bus. As noted earlier, in the event of simultaneous accesses, the eDMA engine is given priority and the peripheral transaction is stalled.
Memory array	TCD storage is implemented using a single-port, synchronous RAM array.

21.1.3 Features

The eDMA is a highly-programmable data-transfer engine optimized to minimize the required intervention from the host processor. It is intended for use in applications where the data size to be transferred is statically known and not defined within the data packet itself. The eDMA module features:

- All data movement via dual-address transfers: read from source, write to destination
 - Programmable source and destination addresses and transfer size
 - Support for enhanced addressing modes
- 16-channel implementation that performs complex data transfers with minimal intervention from a host processor
 - Internal data buffer, used as temporary storage to support 16-byte burst transfers
 - Connections to the crossbar switch for bus mastering the data movement
- Transfer control descriptor (TCD) organized to support two-deep, nested transfer operations
 - 32-byte TCD stored in local memory for each channel
 - An inner data transfer loop defined by a minor byte transfer count
 - An outer data transfer loop defined by a major iteration count
- Channel activation via one of three methods:
 - Explicit software initiation
 - Initiation via a channel-to-channel linking mechanism for continuous transfers
 - Peripheral-paced hardware requests, one per channel
- Fixed-priority and round-robin channel arbitration

- Channel completion reported via optional interrupt requests
 - One interrupt per channel, optionally asserted at completion of major iteration count
 - Optional error terminations per channel and logically summed together to form one error interrupt to the interrupt controller
- Optional support for scatter/gather DMA processing
- Support for complex data structures
- Support to cancel transfers via software

In the discussion of this module, *n* is used to reference the channel number.

21.2 Modes of operation

The eDMA operates in the following modes:

Table 21-3. Modes of operation

Mode	Description
Normal	<p>In Normal mode, the eDMA transfers data between a source and a destination. The source and destination can be a memory block or an I/O block capable of operation with the eDMA.</p> <p>A service request initiates a transfer of a specific number of bytes (NBYTES) as specified in the transfer control descriptor (TCD). The minor loop is the sequence of read-write operations that transfers these NBYTES per service request. Each service request executes one iteration of the major loop, which transfers NBYTES of data.</p>
Debug	<p>DMA operation is configurable in Debug mode via the control register:</p> <ul style="list-style-type: none"> • If CR[EDBG] is cleared, the DMA continues to operate. • If CR[EDBG] is set, the eDMA stops transferring data. <p>If Debug mode is entered while a channel is active, the eDMA continues operation until the channel retires.</p>
Wait	<p>Before entering Wait mode, the DMA attempts to complete its current transfer. After the transfer completes, the device enters Wait mode.</p>

21.3 Memory map/register definition

The eDMA's programming model is partitioned into two regions:

- The first region defines a number of registers providing control functions
- The second region corresponds to the local transfer control descriptor memory

Each channel requires a 32-byte transfer control descriptor for defining the desired data movement operation. The channel descriptors are stored in the local memory in sequential order: channel 0, channel 1,... channel 15 . Each TCD_n definition is presented as 11 registers of 16 or 32 bits.

Reading reserved bits in a register returns the value of zero. Writes to reserved bits in a register are ignored. Reading or writing a reserved memory location generates a bus error.

DMA memory map

Absolute address (hex)	Register name	Width (in bits)	Access	Reset value	Section/ page
4000_8000	Control Register (DMA_CR)	32	R/W	0000_0000h	21.3.1/430
4000_8004	Error Status Register (DMA_ES)	32	R	0000_0000h	21.3.2/432
4000_800C	Enable Request Register (DMA_ERQ)	32	R/W	0000_0000h	21.3.3/434
4000_8014	Enable Error Interrupt Register (DMA_EEI)	32	R/W	0000_0000h	21.3.4/436
4000_8018	Clear Enable Error Interrupt Register (DMA_CEEI)	8	W (always reads zero)	00h	21.3.5/438
4000_8019	Set Enable Error Interrupt Register (DMA_SEEI)	8	W (always reads zero)	00h	21.3.6/439
4000_801A	Clear Enable Request Register (DMA_CERQ)	8	W (always reads zero)	00h	21.3.7/440
4000_801B	Set Enable Request Register (DMA_SERQ)	8	W (always reads zero)	00h	21.3.8/441
4000_801C	Clear DONE Status Bit Register (DMA_CDNE)	8	W (always reads zero)	00h	21.3.9/442
4000_801D	Set START Bit Register (DMA_SSRT)	8	W (always reads zero)	00h	21.3.10/443

Table continues on the next page...

DMA memory map (continued)

Absolute address (hex)	Register name	Width (in bits)	Access	Reset value	Section/page
4000_801E	Clear Error Register (DMA_CERR)	8	W (always reads zero)	00h	21.3.11/444
4000_801F	Clear Interrupt Request Register (DMA_CINT)	8	W (always reads zero)	00h	21.3.12/445
4000_8024	Interrupt Request Register (DMA_INT)	32	R/W	0000_0000h	21.3.13/445
4000_802C	Error Register (DMA_ERR)	32	R/W	0000_0000h	21.3.14/448
4000_8034	Hardware Request Status Register (DMA_HRS)	32	R/W	0000_0000h	21.3.15/450
4000_8100	Channel n Priority Register (DMA_DCHPRI3)	8	R/W	Undefined	21.3.16/452
4000_8101	Channel n Priority Register (DMA_DCHPRI2)	8	R/W	Undefined	21.3.16/452
4000_8102	Channel n Priority Register (DMA_DCHPRI1)	8	R/W	Undefined	21.3.16/452
4000_8103	Channel n Priority Register (DMA_DCHPRI0)	8	R/W	Undefined	21.3.16/452
4000_8104	Channel n Priority Register (DMA_DCHPRI7)	8	R/W	Undefined	21.3.16/452
4000_8105	Channel n Priority Register (DMA_DCHPRI6)	8	R/W	Undefined	21.3.16/452
4000_8106	Channel n Priority Register (DMA_DCHPRI5)	8	R/W	Undefined	21.3.16/452
4000_8107	Channel n Priority Register (DMA_DCHPRI4)	8	R/W	Undefined	21.3.16/452
4000_8108	Channel n Priority Register (DMA_DCHPRI11)	8	R/W	Undefined	21.3.16/452
4000_8109	Channel n Priority Register (DMA_DCHPRI10)	8	R/W	Undefined	21.3.16/452
4000_810A	Channel n Priority Register (DMA_DCHPRI9)	8	R/W	Undefined	21.3.16/452
4000_810B	Channel n Priority Register (DMA_DCHPRI8)	8	R/W	Undefined	21.3.16/452
4000_810C	Channel n Priority Register (DMA_DCHPRI15)	8	R/W	Undefined	21.3.16/452
4000_810D	Channel n Priority Register (DMA_DCHPRI14)	8	R/W	Undefined	21.3.16/452

Table continues on the next page...

DMA memory map (continued)

Absolute address (hex)	Register name	Width (in bits)	Access	Reset value	Section/page
4000_810E	Channel n Priority Register (DMA_DCHPRI13)	8	R/W	Undefined	21.3.16/452
4000_810F	Channel n Priority Register (DMA_DCHPRI12)	8	R/W	Undefined	21.3.16/452
4000_9000	TCD Source Address (DMA_TCD0_SADDR)	32	R/W	Undefined	21.3.17/453
4000_9004	TCD Signed Source Address Offset (DMA_TCD0_SOFF)	16	R/W	Undefined	21.3.18/454
4000_9006	TCD Transfer Attributes (DMA_TCD0_ATTR)	16	R/W	Undefined	21.3.19/454
4000_9008	TCD Minor Byte Count (Minor Loop Disabled) (DMA_TCD0_NBYTES_MLNO)	32	R/W	Undefined	21.3.20/455
4000_9008	TCD Signed Minor Loop Offset (Minor Loop Enabled and Offset Disabled) (DMA_TCD0_NBYTES_MLOFFNO)	32	R/W	Undefined	21.3.21/456
4000_9008	TCD Signed Minor Loop Offset (Minor Loop and Offset Enabled) (DMA_TCD0_NBYTES_MLOFFYES)	32	R/W	Undefined	21.3.22/457
4000_900C	TCD Last Source Address Adjustment (DMA_TCD0_SLAST)	32	R/W	Undefined	21.3.23/458
4000_9010	TCD Destination Address (DMA_TCD0_DADDR)	32	R/W	Undefined	21.3.24/458
4000_9014	TCD Signed Destination Address Offset (DMA_TCD0_DOFF)	16	R/W	Undefined	21.3.25/459
4000_9016	TCD Current Minor Loop Link, Major Loop Count (Channel Linking Enabled) (DMA_TCD0_CITER_ELINKYES)	16	R/W	Undefined	21.3.26/459
4000_9016	DMA_TCD0_CITER_ELINKNO	16	R/W	Undefined	21.3.27/460
4000_9018	TCD Last Destination Address Adjustment/Scatter Gather Address (DMA_TCD0_DLASTSGA)	32	R/W	Undefined	21.3.28/461
4000_901C	TCD Control and Status (DMA_TCD0_CSR)	16	R/W	Undefined	21.3.29/462
4000_901E	TCD Beginning Minor Loop Link, Major Loop Count (Channel Linking Enabled) (DMA_TCD0_BITER_ELINKYES)	16	R/W	Undefined	21.3.30/464
4000_901E	TCD Beginning Minor Loop Link, Major Loop Count (Channel Linking Disabled) (DMA_TCD0_BITER_ELINKNO)	16	R/W	Undefined	21.3.31/465
4000_9020	TCD Source Address (DMA_TCD1_SADDR)	32	R/W	Undefined	21.3.17/453
4000_9024	TCD Signed Source Address Offset (DMA_TCD1_SOFF)	16	R/W	Undefined	21.3.18/454
4000_9026	TCD Transfer Attributes (DMA_TCD1_ATTR)	16	R/W	Undefined	21.3.19/454

Table continues on the next page...

DMA memory map (continued)

Absolute address (hex)	Register name	Width (in bits)	Access	Reset value	Section/page
4000_9028	TCD Minor Byte Count (Minor Loop Disabled) (DMA_TCD1_NBYTES_MLNO)	32	R/W	Undefined	21.3.20/ 455
4000_9028	TCD Signed Minor Loop Offset (Minor Loop Enabled and Offset Disabled) (DMA_TCD1_NBYTES_MLOFFNO)	32	R/W	Undefined	21.3.21/ 456
4000_9028	TCD Signed Minor Loop Offset (Minor Loop and Offset Enabled) (DMA_TCD1_NBYTES_MLOFFYES)	32	R/W	Undefined	21.3.22/ 457
4000_902C	TCD Last Source Address Adjustment (DMA_TCD1_SLAST)	32	R/W	Undefined	21.3.23/ 458
4000_9030	TCD Destination Address (DMA_TCD1_DADDR)	32	R/W	Undefined	21.3.24/ 458
4000_9034	TCD Signed Destination Address Offset (DMA_TCD1_DOFF)	16	R/W	Undefined	21.3.25/ 459
4000_9036	TCD Current Minor Loop Link, Major Loop Count (Channel Linking Enabled) (DMA_TCD1_CITER_ELINKYES)	16	R/W	Undefined	21.3.26/ 459
4000_9036	DMA_TCD1_CITER_ELINKNO	16	R/W	Undefined	21.3.27/ 460
4000_9038	TCD Last Destination Address Adjustment/Scatter Gather Address (DMA_TCD1_DLASTGA)	32	R/W	Undefined	21.3.28/ 461
4000_903C	TCD Control and Status (DMA_TCD1_CSR)	16	R/W	Undefined	21.3.29/ 462
4000_903E	TCD Beginning Minor Loop Link, Major Loop Count (Channel Linking Enabled) (DMA_TCD1_BITER_ELINKYES)	16	R/W	Undefined	21.3.30/ 464
4000_903E	TCD Beginning Minor Loop Link, Major Loop Count (Channel Linking Disabled) (DMA_TCD1_BITER_ELINKNO)	16	R/W	Undefined	21.3.31/ 465
4000_9040	TCD Source Address (DMA_TCD2_SADDR)	32	R/W	Undefined	21.3.17/ 453
4000_9044	TCD Signed Source Address Offset (DMA_TCD2_SOFF)	16	R/W	Undefined	21.3.18/ 454
4000_9046	TCD Transfer Attributes (DMA_TCD2_ATTR)	16	R/W	Undefined	21.3.19/ 454
4000_9048	TCD Minor Byte Count (Minor Loop Disabled) (DMA_TCD2_NBYTES_MLNO)	32	R/W	Undefined	21.3.20/ 455
4000_9048	TCD Signed Minor Loop Offset (Minor Loop Enabled and Offset Disabled) (DMA_TCD2_NBYTES_MLOFFNO)	32	R/W	Undefined	21.3.21/ 456
4000_9048	TCD Signed Minor Loop Offset (Minor Loop and Offset Enabled) (DMA_TCD2_NBYTES_MLOFFYES)	32	R/W	Undefined	21.3.22/ 457
4000_904C	TCD Last Source Address Adjustment (DMA_TCD2_SLAST)	32	R/W	Undefined	21.3.23/ 458
4000_9050	TCD Destination Address (DMA_TCD2_DADDR)	32	R/W	Undefined	21.3.24/ 458

Table continues on the next page...

DMA memory map (continued)

Absolute address (hex)	Register name	Width (in bits)	Access	Reset value	Section/page
4000_9054	TCD Signed Destination Address Offset (DMA_TCD2_DOFF)	16	R/W	Undefined	21.3.25/459
4000_9056	TCD Current Minor Loop Link, Major Loop Count (Channel Linking Enabled) (DMA_TCD2_CITER_ELINKYES)	16	R/W	Undefined	21.3.26/459
4000_9056	DMA_TCD2_CITER_ELINKNO	16	R/W	Undefined	21.3.27/460
4000_9058	TCD Last Destination Address Adjustment/Scatter Gather Address (DMA_TCD2_DLASTSGA)	32	R/W	Undefined	21.3.28/461
4000_905C	TCD Control and Status (DMA_TCD2_CSR)	16	R/W	Undefined	21.3.29/462
4000_905E	TCD Beginning Minor Loop Link, Major Loop Count (Channel Linking Enabled) (DMA_TCD2_BITER_ELINKYES)	16	R/W	Undefined	21.3.30/464
4000_905E	TCD Beginning Minor Loop Link, Major Loop Count (Channel Linking Disabled) (DMA_TCD2_BITER_ELINKNO)	16	R/W	Undefined	21.3.31/465
4000_9060	TCD Source Address (DMA_TCD3_SADDR)	32	R/W	Undefined	21.3.17/453
4000_9064	TCD Signed Source Address Offset (DMA_TCD3_SOFF)	16	R/W	Undefined	21.3.18/454
4000_9066	TCD Transfer Attributes (DMA_TCD3_ATTR)	16	R/W	Undefined	21.3.19/454
4000_9068	TCD Minor Byte Count (Minor Loop Disabled) (DMA_TCD3_NBYTES_MLNO)	32	R/W	Undefined	21.3.20/455
4000_9068	TCD Signed Minor Loop Offset (Minor Loop Enabled and Offset Disabled) (DMA_TCD3_NBYTES_MLOFFNO)	32	R/W	Undefined	21.3.21/456
4000_9068	TCD Signed Minor Loop Offset (Minor Loop and Offset Enabled) (DMA_TCD3_NBYTES_MLOFFYES)	32	R/W	Undefined	21.3.22/457
4000_906C	TCD Last Source Address Adjustment (DMA_TCD3_SLAST)	32	R/W	Undefined	21.3.23/458
4000_9070	TCD Destination Address (DMA_TCD3_DADDR)	32	R/W	Undefined	21.3.24/458
4000_9074	TCD Signed Destination Address Offset (DMA_TCD3_DOFF)	16	R/W	Undefined	21.3.25/459
4000_9076	TCD Current Minor Loop Link, Major Loop Count (Channel Linking Enabled) (DMA_TCD3_CITER_ELINKYES)	16	R/W	Undefined	21.3.26/459
4000_9076	DMA_TCD3_CITER_ELINKNO	16	R/W	Undefined	21.3.27/460
4000_9078	TCD Last Destination Address Adjustment/Scatter Gather Address (DMA_TCD3_DLASTSGA)	32	R/W	Undefined	21.3.28/461
4000_907C	TCD Control and Status (DMA_TCD3_CSR)	16	R/W	Undefined	21.3.29/462

Table continues on the next page...

DMA memory map (continued)

Absolute address (hex)	Register name	Width (in bits)	Access	Reset value	Section/page
4000_907E	TCD Beginning Minor Loop Link, Major Loop Count (Channel Linking Enabled) (DMA_TCD3_BITER_ELINKYES)	16	R/W	Undefined	21.3.30/ 464
4000_907E	TCD Beginning Minor Loop Link, Major Loop Count (Channel Linking Disabled) (DMA_TCD3_BITER_ELINKNO)	16	R/W	Undefined	21.3.31/ 465
4000_9080	TCD Source Address (DMA_TCD4_SADDR)	32	R/W	Undefined	21.3.17/ 453
4000_9084	TCD Signed Source Address Offset (DMA_TCD4_SOFF)	16	R/W	Undefined	21.3.18/ 454
4000_9086	TCD Transfer Attributes (DMA_TCD4_ATTR)	16	R/W	Undefined	21.3.19/ 454
4000_9088	TCD Minor Byte Count (Minor Loop Disabled) (DMA_TCD4_NBYTES_MLNO)	32	R/W	Undefined	21.3.20/ 455
4000_9088	TCD Signed Minor Loop Offset (Minor Loop Enabled and Offset Disabled) (DMA_TCD4_NBYTES_MLOFFNO)	32	R/W	Undefined	21.3.21/ 456
4000_9088	TCD Signed Minor Loop Offset (Minor Loop and Offset Enabled) (DMA_TCD4_NBYTES_MLOFFYES)	32	R/W	Undefined	21.3.22/ 457
4000_908C	TCD Last Source Address Adjustment (DMA_TCD4_SLAST)	32	R/W	Undefined	21.3.23/ 458
4000_9090	TCD Destination Address (DMA_TCD4_DADDR)	32	R/W	Undefined	21.3.24/ 458
4000_9094	TCD Signed Destination Address Offset (DMA_TCD4_DOFF)	16	R/W	Undefined	21.3.25/ 459
4000_9096	TCD Current Minor Loop Link, Major Loop Count (Channel Linking Enabled) (DMA_TCD4_CITER_ELINKYES)	16	R/W	Undefined	21.3.26/ 459
4000_9096	DMA_TCD4_CITER_ELINKNO	16	R/W	Undefined	21.3.27/ 460
4000_9098	TCD Last Destination Address Adjustment/Scatter Gather Address (DMA_TCD4_DLASTSGA)	32	R/W	Undefined	21.3.28/ 461
4000_909C	TCD Control and Status (DMA_TCD4_CSR)	16	R/W	Undefined	21.3.29/ 462
4000_909E	TCD Beginning Minor Loop Link, Major Loop Count (Channel Linking Enabled) (DMA_TCD4_BITER_ELINKYES)	16	R/W	Undefined	21.3.30/ 464
4000_909E	TCD Beginning Minor Loop Link, Major Loop Count (Channel Linking Disabled) (DMA_TCD4_BITER_ELINKNO)	16	R/W	Undefined	21.3.31/ 465
4000_90A0	TCD Source Address (DMA_TCD5_SADDR)	32	R/W	Undefined	21.3.17/ 453
4000_90A4	TCD Signed Source Address Offset (DMA_TCD5_SOFF)	16	R/W	Undefined	21.3.18/ 454

Table continues on the next page...

DMA memory map (continued)

Absolute address (hex)	Register name	Width (in bits)	Access	Reset value	Section/page
4000_90A6	TCD Transfer Attributes (DMA_TCD5_ATTR)	16	R/W	Undefined	21.3.19/ 454
4000_90A8	TCD Minor Byte Count (Minor Loop Disabled) (DMA_TCD5_NBYTES_MLNO)	32	R/W	Undefined	21.3.20/ 455
4000_90A8	TCD Signed Minor Loop Offset (Minor Loop Enabled and Offset Disabled) (DMA_TCD5_NBYTES_MLOFFNO)	32	R/W	Undefined	21.3.21/ 456
4000_90A8	TCD Signed Minor Loop Offset (Minor Loop and Offset Enabled) (DMA_TCD5_NBYTES_MLOFFYES)	32	R/W	Undefined	21.3.22/ 457
4000_90AC	TCD Last Source Address Adjustment (DMA_TCD5_SLAST)	32	R/W	Undefined	21.3.23/ 458
4000_90B0	TCD Destination Address (DMA_TCD5_DADDR)	32	R/W	Undefined	21.3.24/ 458
4000_90B4	TCD Signed Destination Address Offset (DMA_TCD5_DOFF)	16	R/W	Undefined	21.3.25/ 459
4000_90B6	TCD Current Minor Loop Link, Major Loop Count (Channel Linking Enabled) (DMA_TCD5_CITER_ELINKYES)	16	R/W	Undefined	21.3.26/ 459
4000_90B6	DMA_TCD5_CITER_ELINKNO	16	R/W	Undefined	21.3.27/ 460
4000_90B8	TCD Last Destination Address Adjustment/Scatter Gather Address (DMA_TCD5_DLASTSGA)	32	R/W	Undefined	21.3.28/ 461
4000_90BC	TCD Control and Status (DMA_TCD5_CSR)	16	R/W	Undefined	21.3.29/ 462
4000_90BE	TCD Beginning Minor Loop Link, Major Loop Count (Channel Linking Enabled) (DMA_TCD5_BITER_ELINKYES)	16	R/W	Undefined	21.3.30/ 464
4000_90BE	TCD Beginning Minor Loop Link, Major Loop Count (Channel Linking Disabled) (DMA_TCD5_BITER_ELINKNO)	16	R/W	Undefined	21.3.31/ 465
4000_90C0	TCD Source Address (DMA_TCD6_SADDR)	32	R/W	Undefined	21.3.17/ 453
4000_90C4	TCD Signed Source Address Offset (DMA_TCD6_SOFF)	16	R/W	Undefined	21.3.18/ 454
4000_90C6	TCD Transfer Attributes (DMA_TCD6_ATTR)	16	R/W	Undefined	21.3.19/ 454
4000_90C8	TCD Minor Byte Count (Minor Loop Disabled) (DMA_TCD6_NBYTES_MLNO)	32	R/W	Undefined	21.3.20/ 455
4000_90C8	TCD Signed Minor Loop Offset (Minor Loop Enabled and Offset Disabled) (DMA_TCD6_NBYTES_MLOFFNO)	32	R/W	Undefined	21.3.21/ 456
4000_90C8	TCD Signed Minor Loop Offset (Minor Loop and Offset Enabled) (DMA_TCD6_NBYTES_MLOFFYES)	32	R/W	Undefined	21.3.22/ 457
4000_90CC	TCD Last Source Address Adjustment (DMA_TCD6_SLAST)	32	R/W	Undefined	21.3.23/ 458

Table continues on the next page...

DMA memory map (continued)

Absolute address (hex)	Register name	Width (in bits)	Access	Reset value	Section/page
4000_90D0	TCD Destination Address (DMA_TCD6_DADDR)	32	R/W	Undefined	21.3.24/ 458
4000_90D4	TCD Signed Destination Address Offset (DMA_TCD6_DOFF)	16	R/W	Undefined	21.3.25/ 459
4000_90D6	TCD Current Minor Loop Link, Major Loop Count (Channel Linking Enabled) (DMA_TCD6_CITER_ELINKYES)	16	R/W	Undefined	21.3.26/ 459
4000_90D6	DMA_TCD6_CITER_ELINKNO	16	R/W	Undefined	21.3.27/ 460
4000_90D8	TCD Last Destination Address Adjustment/Scatter Gather Address (DMA_TCD6_DLASTSGA)	32	R/W	Undefined	21.3.28/ 461
4000_90DC	TCD Control and Status (DMA_TCD6_CSR)	16	R/W	Undefined	21.3.29/ 462
4000_90DE	TCD Beginning Minor Loop Link, Major Loop Count (Channel Linking Enabled) (DMA_TCD6_BITER_ELINKYES)	16	R/W	Undefined	21.3.30/ 464
4000_90DE	TCD Beginning Minor Loop Link, Major Loop Count (Channel Linking Disabled) (DMA_TCD6_BITER_ELINKNO)	16	R/W	Undefined	21.3.31/ 465
4000_90E0	TCD Source Address (DMA_TCD7_SADDR)	32	R/W	Undefined	21.3.17/ 453
4000_90E4	TCD Signed Source Address Offset (DMA_TCD7_SOFF)	16	R/W	Undefined	21.3.18/ 454
4000_90E6	TCD Transfer Attributes (DMA_TCD7_ATTR)	16	R/W	Undefined	21.3.19/ 454
4000_90E8	TCD Minor Byte Count (Minor Loop Disabled) (DMA_TCD7_NBYTES_MLNO)	32	R/W	Undefined	21.3.20/ 455
4000_90E8	TCD Signed Minor Loop Offset (Minor Loop Enabled and Offset Disabled) (DMA_TCD7_NBYTES_MLOFFNO)	32	R/W	Undefined	21.3.21/ 456
4000_90E8	TCD Signed Minor Loop Offset (Minor Loop and Offset Enabled) (DMA_TCD7_NBYTES_MLOFFYES)	32	R/W	Undefined	21.3.22/ 457
4000_90EC	TCD Last Source Address Adjustment (DMA_TCD7_SLAST)	32	R/W	Undefined	21.3.23/ 458
4000_90F0	TCD Destination Address (DMA_TCD7_DADDR)	32	R/W	Undefined	21.3.24/ 458
4000_90F4	TCD Signed Destination Address Offset (DMA_TCD7_DOFF)	16	R/W	Undefined	21.3.25/ 459
4000_90F6	TCD Current Minor Loop Link, Major Loop Count (Channel Linking Enabled) (DMA_TCD7_CITER_ELINKYES)	16	R/W	Undefined	21.3.26/ 459
4000_90F6	DMA_TCD7_CITER_ELINKNO	16	R/W	Undefined	21.3.27/ 460
4000_90F8	TCD Last Destination Address Adjustment/Scatter Gather Address (DMA_TCD7_DLASTSGA)	32	R/W	Undefined	21.3.28/ 461

Table continues on the next page...

DMA memory map (continued)

Absolute address (hex)	Register name	Width (in bits)	Access	Reset value	Section/page
4000_90FC	TCD Control and Status (DMA_TCD7_CSR)	16	R/W	Undefined	21.3.29/462
4000_90FE	TCD Beginning Minor Loop Link, Major Loop Count (Channel Linking Enabled) (DMA_TCD7_BITER_ELINKYES)	16	R/W	Undefined	21.3.30/464
4000_90FE	TCD Beginning Minor Loop Link, Major Loop Count (Channel Linking Disabled) (DMA_TCD7_BITER_ELINKNO)	16	R/W	Undefined	21.3.31/465
4000_9100	TCD Source Address (DMA_TCD8_SADDR)	32	R/W	Undefined	21.3.17/453
4000_9104	TCD Signed Source Address Offset (DMA_TCD8_SOFF)	16	R/W	Undefined	21.3.18/454
4000_9106	TCD Transfer Attributes (DMA_TCD8_ATTR)	16	R/W	Undefined	21.3.19/454
4000_9108	TCD Minor Byte Count (Minor Loop Disabled) (DMA_TCD8_NBYTES_MLNO)	32	R/W	Undefined	21.3.20/455
4000_9108	TCD Signed Minor Loop Offset (Minor Loop Enabled and Offset Disabled) (DMA_TCD8_NBYTES_MLOFFNO)	32	R/W	Undefined	21.3.21/456
4000_9108	TCD Signed Minor Loop Offset (Minor Loop and Offset Enabled) (DMA_TCD8_NBYTES_MLOFFYES)	32	R/W	Undefined	21.3.22/457
4000_910C	TCD Last Source Address Adjustment (DMA_TCD8_SLAST)	32	R/W	Undefined	21.3.23/458
4000_9110	TCD Destination Address (DMA_TCD8_DADDR)	32	R/W	Undefined	21.3.24/458
4000_9114	TCD Signed Destination Address Offset (DMA_TCD8_DOFF)	16	R/W	Undefined	21.3.25/459
4000_9116	TCD Current Minor Loop Link, Major Loop Count (Channel Linking Enabled) (DMA_TCD8_CITER_ELINKYES)	16	R/W	Undefined	21.3.26/459
4000_9116	DMA_TCD8_CITER_ELINKNO	16	R/W	Undefined	21.3.27/460
4000_9118	TCD Last Destination Address Adjustment/Scatter Gather Address (DMA_TCD8_DLASTSGA)	32	R/W	Undefined	21.3.28/461
4000_911C	TCD Control and Status (DMA_TCD8_CSR)	16	R/W	Undefined	21.3.29/462
4000_911E	TCD Beginning Minor Loop Link, Major Loop Count (Channel Linking Enabled) (DMA_TCD8_BITER_ELINKYES)	16	R/W	Undefined	21.3.30/464
4000_911E	TCD Beginning Minor Loop Link, Major Loop Count (Channel Linking Disabled) (DMA_TCD8_BITER_ELINKNO)	16	R/W	Undefined	21.3.31/465
4000_9120	TCD Source Address (DMA_TCD9_SADDR)	32	R/W	Undefined	21.3.17/453

Table continues on the next page...

DMA memory map (continued)

Absolute address (hex)	Register name	Width (in bits)	Access	Reset value	Section/page
4000_9124	TCD Signed Source Address Offset (DMA_TCD9_SOFF)	16	R/W	Undefined	21.3.18/ 454
4000_9126	TCD Transfer Attributes (DMA_TCD9_ATTR)	16	R/W	Undefined	21.3.19/ 454
4000_9128	TCD Minor Byte Count (Minor Loop Disabled) (DMA_TCD9_NBYTES_MLNO)	32	R/W	Undefined	21.3.20/ 455
4000_9128	TCD Signed Minor Loop Offset (Minor Loop Enabled and Offset Disabled) (DMA_TCD9_NBYTES_MLOFFNO)	32	R/W	Undefined	21.3.21/ 456
4000_9128	TCD Signed Minor Loop Offset (Minor Loop and Offset Enabled) (DMA_TCD9_NBYTES_MLOFFYES)	32	R/W	Undefined	21.3.22/ 457
4000_912C	TCD Last Source Address Adjustment (DMA_TCD9_SLAST)	32	R/W	Undefined	21.3.23/ 458
4000_9130	TCD Destination Address (DMA_TCD9_DADDR)	32	R/W	Undefined	21.3.24/ 458
4000_9134	TCD Signed Destination Address Offset (DMA_TCD9_DOFF)	16	R/W	Undefined	21.3.25/ 459
4000_9136	TCD Current Minor Loop Link, Major Loop Count (Channel Linking Enabled) (DMA_TCD9_CITER_ELINKYES)	16	R/W	Undefined	21.3.26/ 459
4000_9136	DMA_TCD9_CITER_ELINKNO	16	R/W	Undefined	21.3.27/ 460
4000_9138	TCD Last Destination Address Adjustment/Scatter Gather Address (DMA_TCD9_DLASTSGA)	32	R/W	Undefined	21.3.28/ 461
4000_913C	TCD Control and Status (DMA_TCD9_CSR)	16	R/W	Undefined	21.3.29/ 462
4000_913E	TCD Beginning Minor Loop Link, Major Loop Count (Channel Linking Enabled) (DMA_TCD9_BITER_ELINKYES)	16	R/W	Undefined	21.3.30/ 464
4000_913E	TCD Beginning Minor Loop Link, Major Loop Count (Channel Linking Disabled) (DMA_TCD9_BITER_ELINKNO)	16	R/W	Undefined	21.3.31/ 465
4000_9140	TCD Source Address (DMA_TCD10_SADDR)	32	R/W	Undefined	21.3.17/ 453
4000_9144	TCD Signed Source Address Offset (DMA_TCD10_SOFF)	16	R/W	Undefined	21.3.18/ 454
4000_9146	TCD Transfer Attributes (DMA_TCD10_ATTR)	16	R/W	Undefined	21.3.19/ 454
4000_9148	TCD Minor Byte Count (Minor Loop Disabled) (DMA_TCD10_NBYTES_MLNO)	32	R/W	Undefined	21.3.20/ 455
4000_9148	TCD Signed Minor Loop Offset (Minor Loop Enabled and Offset Disabled) (DMA_TCD10_NBYTES_MLOFFNO)	32	R/W	Undefined	21.3.21/ 456
4000_9148	TCD Signed Minor Loop Offset (Minor Loop and Offset Enabled) (DMA_TCD10_NBYTES_MLOFFYES)	32	R/W	Undefined	21.3.22/ 457

Table continues on the next page...

DMA memory map (continued)

Absolute address (hex)	Register name	Width (in bits)	Access	Reset value	Section/page
4000_914C	TCD Last Source Address Adjustment (DMA_TCD10_SLAST)	32	R/W	Undefined	21.3.23/ 458
4000_9150	TCD Destination Address (DMA_TCD10_DADDR)	32	R/W	Undefined	21.3.24/ 458
4000_9154	TCD Signed Destination Address Offset (DMA_TCD10_DOFF)	16	R/W	Undefined	21.3.25/ 459
4000_9156	TCD Current Minor Loop Link, Major Loop Count (Channel Linking Enabled) (DMA_TCD10_CITER_ELINKYES)	16	R/W	Undefined	21.3.26/ 459
4000_9156	DMA_TCD10_CITER_ELINKNO	16	R/W	Undefined	21.3.27/ 460
4000_9158	TCD Last Destination Address Adjustment/Scatter Gather Address (DMA_TCD10_DLASTSGA)	32	R/W	Undefined	21.3.28/ 461
4000_915C	TCD Control and Status (DMA_TCD10_CSR)	16	R/W	Undefined	21.3.29/ 462
4000_915E	TCD Beginning Minor Loop Link, Major Loop Count (Channel Linking Enabled) (DMA_TCD10_BITER_ELINKYES)	16	R/W	Undefined	21.3.30/ 464
4000_915E	TCD Beginning Minor Loop Link, Major Loop Count (Channel Linking Disabled) (DMA_TCD10_BITER_ELINKNO)	16	R/W	Undefined	21.3.31/ 465
4000_9160	TCD Source Address (DMA_TCD11_SADDR)	32	R/W	Undefined	21.3.17/ 453
4000_9164	TCD Signed Source Address Offset (DMA_TCD11_SOFF)	16	R/W	Undefined	21.3.18/ 454
4000_9166	TCD Transfer Attributes (DMA_TCD11_ATTR)	16	R/W	Undefined	21.3.19/ 454
4000_9168	TCD Minor Byte Count (Minor Loop Disabled) (DMA_TCD11_NBYTES_MLNO)	32	R/W	Undefined	21.3.20/ 455
4000_9168	TCD Signed Minor Loop Offset (Minor Loop Enabled and Offset Disabled) (DMA_TCD11_NBYTES_MLOFFNO)	32	R/W	Undefined	21.3.21/ 456
4000_9168	TCD Signed Minor Loop Offset (Minor Loop and Offset Enabled) (DMA_TCD11_NBYTES_MLOFFYES)	32	R/W	Undefined	21.3.22/ 457
4000_916C	TCD Last Source Address Adjustment (DMA_TCD11_SLAST)	32	R/W	Undefined	21.3.23/ 458
4000_9170	TCD Destination Address (DMA_TCD11_DADDR)	32	R/W	Undefined	21.3.24/ 458
4000_9174	TCD Signed Destination Address Offset (DMA_TCD11_DOFF)	16	R/W	Undefined	21.3.25/ 459
4000_9176	TCD Current Minor Loop Link, Major Loop Count (Channel Linking Enabled) (DMA_TCD11_CITER_ELINKYES)	16	R/W	Undefined	21.3.26/ 459
4000_9176	DMA_TCD11_CITER_ELINKNO	16	R/W	Undefined	21.3.27/ 460

Table continues on the next page...

DMA memory map (continued)

Absolute address (hex)	Register name	Width (in bits)	Access	Reset value	Section/page
4000_9178	TCD Last Destination Address Adjustment/Scatter Gather Address (DMA_TCD11_DLASTSGA)	32	R/W	Undefined	21.3.28/ 461
4000_917C	TCD Control and Status (DMA_TCD11_CSR)	16	R/W	Undefined	21.3.29/ 462
4000_917E	TCD Beginning Minor Loop Link, Major Loop Count (Channel Linking Enabled) (DMA_TCD11_BITER_ELINKYES)	16	R/W	Undefined	21.3.30/ 464
4000_917E	TCD Beginning Minor Loop Link, Major Loop Count (Channel Linking Disabled) (DMA_TCD11_BITER_ELINKNO)	16	R/W	Undefined	21.3.31/ 465
4000_9180	TCD Source Address (DMA_TCD12_SADDR)	32	R/W	Undefined	21.3.17/ 453
4000_9184	TCD Signed Source Address Offset (DMA_TCD12_SOFF)	16	R/W	Undefined	21.3.18/ 454
4000_9186	TCD Transfer Attributes (DMA_TCD12_ATTR)	16	R/W	Undefined	21.3.19/ 454
4000_9188	TCD Minor Byte Count (Minor Loop Disabled) (DMA_TCD12_NBYTES_MLNO)	32	R/W	Undefined	21.3.20/ 455
4000_9188	TCD Signed Minor Loop Offset (Minor Loop Enabled and Offset Disabled) (DMA_TCD12_NBYTES_MLOFFNO)	32	R/W	Undefined	21.3.21/ 456
4000_9188	TCD Signed Minor Loop Offset (Minor Loop and Offset Enabled) (DMA_TCD12_NBYTES_MLOFFYES)	32	R/W	Undefined	21.3.22/ 457
4000_918C	TCD Last Source Address Adjustment (DMA_TCD12_SLAST)	32	R/W	Undefined	21.3.23/ 458
4000_9190	TCD Destination Address (DMA_TCD12_DADDR)	32	R/W	Undefined	21.3.24/ 458
4000_9194	TCD Signed Destination Address Offset (DMA_TCD12_DOFF)	16	R/W	Undefined	21.3.25/ 459
4000_9196	TCD Current Minor Loop Link, Major Loop Count (Channel Linking Enabled) (DMA_TCD12_CITER_ELINKYES)	16	R/W	Undefined	21.3.26/ 459
4000_9196	DMA_TCD12_CITER_ELINKNO	16	R/W	Undefined	21.3.27/ 460
4000_9198	TCD Last Destination Address Adjustment/Scatter Gather Address (DMA_TCD12_DLASTSGA)	32	R/W	Undefined	21.3.28/ 461
4000_919C	TCD Control and Status (DMA_TCD12_CSR)	16	R/W	Undefined	21.3.29/ 462
4000_919E	TCD Beginning Minor Loop Link, Major Loop Count (Channel Linking Enabled) (DMA_TCD12_BITER_ELINKYES)	16	R/W	Undefined	21.3.30/ 464
4000_919E	TCD Beginning Minor Loop Link, Major Loop Count (Channel Linking Disabled) (DMA_TCD12_BITER_ELINKNO)	16	R/W	Undefined	21.3.31/ 465

Table continues on the next page...

DMA memory map (continued)

Absolute address (hex)	Register name	Width (in bits)	Access	Reset value	Section/page
4000_91A0	TCD Source Address (DMA_TCD13_SADDR)	32	R/W	Undefined	21.3.17/ 453
4000_91A4	TCD Signed Source Address Offset (DMA_TCD13_SOFF)	16	R/W	Undefined	21.3.18/ 454
4000_91A6	TCD Transfer Attributes (DMA_TCD13_ATTR)	16	R/W	Undefined	21.3.19/ 454
4000_91A8	TCD Minor Byte Count (Minor Loop Disabled) (DMA_TCD13_NBYTES_MLNO)	32	R/W	Undefined	21.3.20/ 455
4000_91A8	TCD Signed Minor Loop Offset (Minor Loop Enabled and Offset Disabled) (DMA_TCD13_NBYTES_MLOFFNO)	32	R/W	Undefined	21.3.21/ 456
4000_91A8	TCD Signed Minor Loop Offset (Minor Loop and Offset Enabled) (DMA_TCD13_NBYTES_MLOFFYES)	32	R/W	Undefined	21.3.22/ 457
4000_91AC	TCD Last Source Address Adjustment (DMA_TCD13_SLAST)	32	R/W	Undefined	21.3.23/ 458
4000_91B0	TCD Destination Address (DMA_TCD13_DADDR)	32	R/W	Undefined	21.3.24/ 458
4000_91B4	TCD Signed Destination Address Offset (DMA_TCD13_DOFF)	16	R/W	Undefined	21.3.25/ 459
4000_91B6	TCD Current Minor Loop Link, Major Loop Count (Channel Linking Enabled) (DMA_TCD13_CITER_ELINKYES)	16	R/W	Undefined	21.3.26/ 459
4000_91B6	DMA_TCD13_CITER_ELINKNO	16	R/W	Undefined	21.3.27/ 460
4000_91B8	TCD Last Destination Address Adjustment/Scatter Gather Address (DMA_TCD13_DLASTSGA)	32	R/W	Undefined	21.3.28/ 461
4000_91BC	TCD Control and Status (DMA_TCD13_CSR)	16	R/W	Undefined	21.3.29/ 462
4000_91BE	TCD Beginning Minor Loop Link, Major Loop Count (Channel Linking Enabled) (DMA_TCD13_BITER_ELINKYES)	16	R/W	Undefined	21.3.30/ 464
4000_91BE	TCD Beginning Minor Loop Link, Major Loop Count (Channel Linking Disabled) (DMA_TCD13_BITER_ELINKNO)	16	R/W	Undefined	21.3.31/ 465
4000_91C0	TCD Source Address (DMA_TCD14_SADDR)	32	R/W	Undefined	21.3.17/ 453
4000_91C4	TCD Signed Source Address Offset (DMA_TCD14_SOFF)	16	R/W	Undefined	21.3.18/ 454
4000_91C6	TCD Transfer Attributes (DMA_TCD14_ATTR)	16	R/W	Undefined	21.3.19/ 454
4000_91C8	TCD Minor Byte Count (Minor Loop Disabled) (DMA_TCD14_NBYTES_MLNO)	32	R/W	Undefined	21.3.20/ 455
4000_91C8	TCD Signed Minor Loop Offset (Minor Loop Enabled and Offset Disabled) (DMA_TCD14_NBYTES_MLOFFNO)	32	R/W	Undefined	21.3.21/ 456

Table continues on the next page...

DMA memory map (continued)

Absolute address (hex)	Register name	Width (in bits)	Access	Reset value	Section/page
4000_91C8	TCD Signed Minor Loop Offset (Minor Loop and Offset Enabled) (DMA_TCD14_NBYTES_MLOFFYES)	32	R/W	Undefined	21.3.22/ 457
4000_91CC	TCD Last Source Address Adjustment (DMA_TCD14_SLAST)	32	R/W	Undefined	21.3.23/ 458
4000_91D0	TCD Destination Address (DMA_TCD14_DADDR)	32	R/W	Undefined	21.3.24/ 458
4000_91D4	TCD Signed Destination Address Offset (DMA_TCD14_DOFF)	16	R/W	Undefined	21.3.25/ 459
4000_91D6	TCD Current Minor Loop Link, Major Loop Count (Channel Linking Enabled) (DMA_TCD14_CITER_ELINKYES)	16	R/W	Undefined	21.3.26/ 459
4000_91D6	DMA_TCD14_CITER_ELINKNO	16	R/W	Undefined	21.3.27/ 460
4000_91D8	TCD Last Destination Address Adjustment/Scatter Gather Address (DMA_TCD14_DLASTSGA)	32	R/W	Undefined	21.3.28/ 461
4000_91DC	TCD Control and Status (DMA_TCD14_CSR)	16	R/W	Undefined	21.3.29/ 462
4000_91DE	TCD Beginning Minor Loop Link, Major Loop Count (Channel Linking Enabled) (DMA_TCD14_BITER_ELINKYES)	16	R/W	Undefined	21.3.30/ 464
4000_91DE	TCD Beginning Minor Loop Link, Major Loop Count (Channel Linking Disabled) (DMA_TCD14_BITER_ELINKNO)	16	R/W	Undefined	21.3.31/ 465
4000_91E0	TCD Source Address (DMA_TCD15_SADDR)	32	R/W	Undefined	21.3.17/ 453
4000_91E4	TCD Signed Source Address Offset (DMA_TCD15_SOFF)	16	R/W	Undefined	21.3.18/ 454
4000_91E6	TCD Transfer Attributes (DMA_TCD15_ATTR)	16	R/W	Undefined	21.3.19/ 454
4000_91E8	TCD Minor Byte Count (Minor Loop Disabled) (DMA_TCD15_NBYTES_MLNO)	32	R/W	Undefined	21.3.20/ 455
4000_91E8	TCD Signed Minor Loop Offset (Minor Loop Enabled and Offset Disabled) (DMA_TCD15_NBYTES_MLOFFNO)	32	R/W	Undefined	21.3.21/ 456
4000_91E8	TCD Signed Minor Loop Offset (Minor Loop and Offset Enabled) (DMA_TCD15_NBYTES_MLOFFYES)	32	R/W	Undefined	21.3.22/ 457
4000_91EC	TCD Last Source Address Adjustment (DMA_TCD15_SLAST)	32	R/W	Undefined	21.3.23/ 458
4000_91F0	TCD Destination Address (DMA_TCD15_DADDR)	32	R/W	Undefined	21.3.24/ 458
4000_91F4	TCD Signed Destination Address Offset (DMA_TCD15_DOFF)	16	R/W	Undefined	21.3.25/ 459
4000_91F6	TCD Current Minor Loop Link, Major Loop Count (Channel Linking Enabled) (DMA_TCD15_CITER_ELINKYES)	16	R/W	Undefined	21.3.26/ 459

Table continues on the next page...

DMA memory map (continued)

Absolute address (hex)	Register name	Width (in bits)	Access	Reset value	Section/page
4000_91F6	DMA_TCD15_CITER_ELINKNO	16	R/W	Undefined	21.3.27/460
4000_91F8	TCD Last Destination Address Adjustment/Scatter Gather Address (DMA_TCD15_DLASTSGA)	32	R/W	Undefined	21.3.28/461
4000_91FC	TCD Control and Status (DMA_TCD15_CSR)	16	R/W	Undefined	21.3.29/462
4000_91FE	TCD Beginning Minor Loop Link, Major Loop Count (Channel Linking Enabled) (DMA_TCD15_BITER_ELINKYES)	16	R/W	Undefined	21.3.30/464
4000_91FE	TCD Beginning Minor Loop Link, Major Loop Count (Channel Linking Disabled) (DMA_TCD15_BITER_ELINKNO)	16	R/W	Undefined	21.3.31/465

21.3.1 Control Register (DMA_CR)

The CR defines the basic operating configuration of the DMA.

Arbitration can be configured to use either a fixed-priority or a round-robin scheme. For fixed-priority arbitration, the highest priority channel requesting service is selected to execute. The channel priority registers assign the priorities; see the DCHPRIn registers. For round-robin arbitration, the channel priorities are ignored and channels are cycled through without regard to priority.

NOTE

For proper operation, writes to the CR register must be performed only when the DMA channels are inactive; that is, when TCDn_CSR[ACTIVE] bits are cleared.

Address: DMA_CR is 4000_8000h base + 0h offset = 4000_8000h

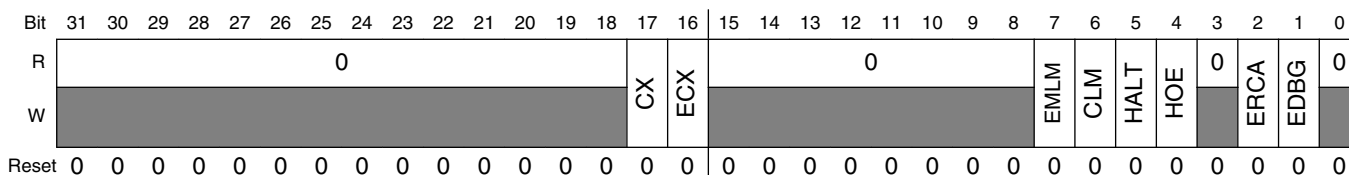

DMA_CR field descriptions

Field	Description
31–18 Reserved	This read-only field is reserved and always has the value zero.
17 CX	Cancel Transfer

Table continues on the next page...

DMA_CR field descriptions (continued)

Field	Description
	<p>0 Normal operation</p> <p>1 Cancel the remaining data transfer. Stop the executing channel and force the minor loop to finish. The cancel takes effect after the last write of the current read/write sequence. The CX bit clears itself after the cancel has been honored. This cancel retires the channel normally as if the minor loop was completed.</p>
16 ECX	<p>Error Cancel Transfer</p> <p>0 Normal operation</p> <p>1 Cancel the remaining data transfer in the same fashion as the CX bit. Stop the executing channel and force the minor loop to finish. The cancel takes effect after the last write of the current read/write sequence. The ECX bit clears itself after the cancel is honored. In addition to cancelling the transfer, ECX treats the cancel as an error condition, thus updating the ES register and generating an optional error interrupt.</p>
15–8 Reserved	This read-only field is reserved and always has the value zero.
7 EMLM	<p>Enable Minor Loop Mapping</p> <p>0 Disabled. TCDn.word2 is defined as a 32-bit NBYTES field.</p> <p>1 Enabled. TCDn.word2 is redefined to include individual enable fields, an offset field, and the NBYTES field. The individual enable fields allow the minor loop offset to be applied to the source address, the destination address, or both. The NBYTES field is reduced when either offset is enabled.</p>
6 CLM	<p>Continuous Link Mode</p> <p>0 A minor loop channel link made to itself goes through channel arbitration before being activated again.</p> <p>1 A minor loop channel link made to itself does not go through channel arbitration before being activated again. Upon minor loop completion, the channel activates again if that channel has a minor loop channel link enabled and the link channel is itself. This effectively applies the minor loop offsets and restarts the next minor loop.</p>
5 HALT	<p>Halt DMA Operations</p> <p>0 Normal operation</p> <p>1 Stall the start of any new channels. Executing channels are allowed to complete. Channel execution resumes when this bit is cleared.</p>
4 HOE	<p>Halt On Error</p> <p>0 Normal operation</p> <p>1 Any error causes the HALT bit to set. Subsequently, all service requests are ignored until the HALT bit is cleared.</p>
3 Reserved	This read-only field is reserved and always has the value zero.
2 ERCA	<p>Enable Round Robin Channel Arbitration</p> <p>0 Fixed priority arbitration is used for channel selection.</p> <p>1 Round robin arbitration is used for channel selection.</p>
1 EDBG	<p>Enable Debug</p>

Table continues on the next page...

DMA_CR field descriptions (continued)

Field	Description
0	When in debug mode, the DMA continues to operate.
1	When in debug mode, the DMA stalls the start of a new channel. Executing channels are allowed to complete. Channel execution resumes when the system exits debug mode or the EDBG bit is cleared.
0 Reserved	This read-only field is reserved and always has the value zero.

21.3.2 Error Status Register (DMA_ES)

The ES provides information concerning the last recorded channel error. Channel errors can be caused by:

- A configuration error, that is:
 - An illegal setting in the transfer-control descriptor, or
 - An illegal priority register setting in fixed-arbitration
- An error termination to a bus master read or write cycle

See the Error Reporting and Handling section for more details.

Address: DMA_ES is 4000_8000h base + 4h offset = 4000_8004h

Bit	31	30	29	28	27	26	25	24	23	22	21	20	19	18	17	16
R	VLD	0														ECX
W	[Greyed out]															
Reset	0	0	0	0	0	0	0	0	0	0	0	0	0	0	0	0
Bit	15	14	13	12	11	10	9	8	7	6	5	4	3	2	1	0
R	0	CPE	0	ERRCHN				SAE	SOE	DAE	DOE	NCE	SGE	SBE	DBE	
W	[Greyed out]															
Reset	0	0	0	0	0	0	0	0	0	0	0	0	0	0	0	0

DMA_ES field descriptions

Field	Description
31 VLD	Logical OR of all ERR status bits 0 No ERR bits are set 1 At least one ERR bit is set indicating a valid error exists that has not been cleared
30–17 Reserved	This read-only field is reserved and always has the value zero.
16 ECX	Transfer Cancelled 0 No cancelled transfers 1 The last recorded entry was a cancelled transfer by the error cancel transfer input

Table continues on the next page...

DMA_ES field descriptions (continued)

Field	Description
15 Reserved	This read-only field is reserved and always has the value zero.
14 CPE	Channel Priority Error 0 No channel priority error 1 The last recorded error was a configuration error in the channel priorities. Channel priorities are not unique.
13–12 Reserved	This read-only field is reserved and always has the value zero.
11–8 ERRCHN	Error Channel Number or Cancelled Channel Number The channel number of the last recorded error (excluding CPE errors) or last recorded error cancelled transfer.
7 SAE	Source Address Error 0 No source address configuration error. 1 The last recorded error was a configuration error detected in the TCDn_SADDR field. TCDn_SADDR is inconsistent with TCDn_ATTR[SSIZE].
6 SOE	Source Offset Error 0 No source offset configuration error 1 The last recorded error was a configuration error detected in the TCDn_SOFF field. TCDn_SOFF is inconsistent with TCDn_ATTR[SSIZE].
5 DAE	Destination Address Error 0 No destination address configuration error 1 The last recorded error was a configuration error detected in the TCDn_DADDR field. TCDn_DADDR is inconsistent with TCDn_ATTR[DSIZE].
4 DOE	Destination Offset Error 0 No destination offset configuration error 1 The last recorded error was a configuration error detected in the TCDn_DOFF field. TCDn_DOFF is inconsistent with TCDn_ATTR[DSIZE].
3 NCE	NBYTES/CITER Configuration Error 0 No NBYTES/CITER configuration error 1 The last recorded error was a configuration error detected in the TCDn_NBYTES or TCDn_CITER fields. <ul style="list-style-type: none"> • TCDn_NBYTES is not a multiple of TCDn_ATTR[SSIZE] and TCDn_ATTR[DSIZE], or • TCDn_CITER[CITER] is equal to zero, or • TCDn_CITER[ELINK] is not equal to TCDn_BITER[ELINK]
2 SGE	Scatter/Gather Configuration Error 0 No scatter/gather configuration error 1 The last recorded error was a configuration error detected in the TCDn_DLASTSGA field. This field is checked at the beginning of a scatter/gather operation after major loop completion if TCDn_CSR[ESG] is enabled. TCDn_DLASTSGA is not on a 32 byte boundary.

Table continues on the next page...

DMA_ES field descriptions (continued)

Field	Description
1 SBE	Source Bus Error 0 No source bus error 1 The last recorded error was a bus error on a source read
0 DBE	Destination Bus Error 0 No destination bus error 1 The last recorded error was a bus error on a destination write

21.3.3 Enable Request Register (DMA_ERQ)

The ERQ register provides a bit map for the 16 implemented channels to enable the request signal for each channel. The state of any given channel enable is directly affected by writes to this register; it is also affected by writes to the SERQ and CERQ. The {S,C}ERQ registers are provided so the request enable for a single channel can easily be modified without needing to perform a read-modify-write sequence to the ERQ.

DMA request input signals and this enable request flag must be asserted before a channel's hardware service request is accepted. The state of the DMA enable request flag does not affect a channel service request made explicitly through software or a linked channel request.

Address: DMA_ERQ is 4000_8000h base + Ch offset = 4000_800Ch

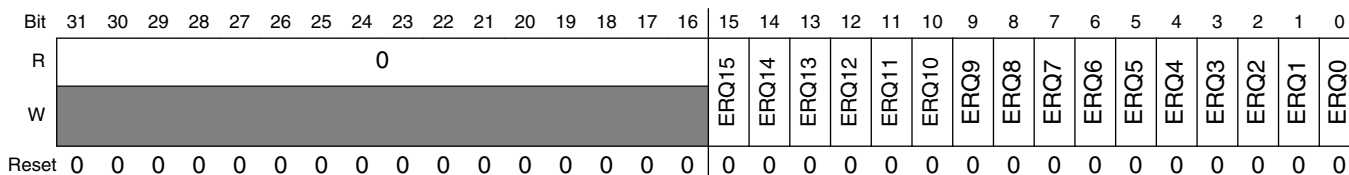

DMA_ERQ field descriptions

Field	Description
31–16 Reserved	This read-only field is reserved and always has the value zero.
15 ERQ15	Enable DMA Request 15 0 The DMA request signal for the corresponding channel is disabled 1 The DMA request signal for the corresponding channel is enabled
14 ERQ14	Enable DMA Request 14 0 The DMA request signal for the corresponding channel is disabled 1 The DMA request signal for the corresponding channel is enabled

Table continues on the next page...

DMA_ERQ field descriptions (continued)

Field	Description
13 ERQ13	Enable DMA Request 13 0 The DMA request signal for the corresponding channel is disabled 1 The DMA request signal for the corresponding channel is enabled
12 ERQ12	Enable DMA Request 12 0 The DMA request signal for the corresponding channel is disabled 1 The DMA request signal for the corresponding channel is enabled
11 ERQ11	Enable DMA Request 11 0 The DMA request signal for the corresponding channel is disabled 1 The DMA request signal for the corresponding channel is enabled
10 ERQ10	Enable DMA Request 10 0 The DMA request signal for the corresponding channel is disabled 1 The DMA request signal for the corresponding channel is enabled
9 ERQ9	Enable DMA Request 9 0 The DMA request signal for the corresponding channel is disabled 1 The DMA request signal for the corresponding channel is enabled
8 ERQ8	Enable DMA Request 8 0 The DMA request signal for the corresponding channel is disabled 1 The DMA request signal for the corresponding channel is enabled
7 ERQ7	Enable DMA Request 7 0 The DMA request signal for the corresponding channel is disabled 1 The DMA request signal for the corresponding channel is enabled
6 ERQ6	Enable DMA Request 6 0 The DMA request signal for the corresponding channel is disabled 1 The DMA request signal for the corresponding channel is enabled
5 ERQ5	Enable DMA Request 5 0 The DMA request signal for the corresponding channel is disabled 1 The DMA request signal for the corresponding channel is enabled
4 ERQ4	Enable DMA Request 4 0 The DMA request signal for the corresponding channel is disabled 1 The DMA request signal for the corresponding channel is enabled
3 ERQ3	Enable DMA Request 3 0 The DMA request signal for the corresponding channel is disabled 1 The DMA request signal for the corresponding channel is enabled
2 ERQ2	Enable DMA Request 2

Table continues on the next page...

DMA_ERQ field descriptions (continued)

Field	Description
	0 The DMA request signal for the corresponding channel is disabled 1 The DMA request signal for the corresponding channel is enabled
1 ERQ1	Enable DMA Request 1 0 The DMA request signal for the corresponding channel is disabled 1 The DMA request signal for the corresponding channel is enabled
0 ERQ0	Enable DMA Request 0 0 The DMA request signal for the corresponding channel is disabled 1 The DMA request signal for the corresponding channel is enabled

21.3.4 Enable Error Interrupt Register (DMA_EEI)

The EEI register provides a bit map for the 16 channels to enable the error interrupt signal for each channel. The state of any given channel’s error interrupt enable is directly affected by writes to this register; it is also affected by writes to the SEEI and CEEI. The {S,C}EEI are provided so the error interrupt enable for a single channel can easily be modified without the need to perform a read-modify-write sequence to the EEI register.

The DMA error indicator and the error interrupt enable flag must be asserted before an error interrupt request for a given channel is asserted to the interrupt controller.

Address: DMA_EEI is 4000_8000h base + 14h offset = 4000_8014h

Bit	31	30	29	28	27	26	25	24	23	22	21	20	19	18	17	16	15	14	13	12	11	10	9	8	7	6	5	4	3	2	1	0
R	0																EEI15	EEI14	EEI13	EEI12	EEI11	EEI10	EEI9	EEI8	EEI7	EEI6	EEI5	EEI4	EEI3	EEI2	EEI1	EEI0
W	[Shaded]																EEI15	EEI14	EEI13	EEI12	EEI11	EEI10	EEI9	EEI8	EEI7	EEI6	EEI5	EEI4	EEI3	EEI2	EEI1	EEI0
Reset	0	0	0	0	0	0	0	0	0	0	0	0	0	0	0	0	0	0	0	0	0	0	0	0	0	0	0	0	0	0	0	

DMA_EEI field descriptions

Field	Description
31–16 Reserved	This read-only field is reserved and always has the value zero.
15 EEI15	Enable Error Interrupt 15 0 The error signal for corresponding channel does not generate an error interrupt 1 The assertion of the error signal for corresponding channel generates an error interrupt request
14 EEI14	Enable Error Interrupt 14 0 The error signal for corresponding channel does not generate an error interrupt 1 The assertion of the error signal for corresponding channel generates an error interrupt request

Table continues on the next page...

DMA_EEI field descriptions (continued)

Field	Description
13 EEI13	Enable Error Interrupt 13 0 The error signal for corresponding channel does not generate an error interrupt 1 The assertion of the error signal for corresponding channel generates an error interrupt request
12 EEI12	Enable Error Interrupt 12 0 The error signal for corresponding channel does not generate an error interrupt 1 The assertion of the error signal for corresponding channel generates an error interrupt request
11 EEI11	Enable Error Interrupt 11 0 The error signal for corresponding channel does not generate an error interrupt 1 The assertion of the error signal for corresponding channel generates an error interrupt request
10 EEI10	Enable Error Interrupt 10 0 The error signal for corresponding channel does not generate an error interrupt 1 The assertion of the error signal for corresponding channel generates an error interrupt request
9 EEI9	Enable Error Interrupt 9 0 The error signal for corresponding channel does not generate an error interrupt 1 The assertion of the error signal for corresponding channel generates an error interrupt request
8 EEI8	Enable Error Interrupt 8 0 The error signal for corresponding channel does not generate an error interrupt 1 The assertion of the error signal for corresponding channel generates an error interrupt request
7 EEI7	Enable Error Interrupt 7 0 The error signal for corresponding channel does not generate an error interrupt 1 The assertion of the error signal for corresponding channel generates an error interrupt request
6 EEI6	Enable Error Interrupt 6 0 The error signal for corresponding channel does not generate an error interrupt 1 The assertion of the error signal for corresponding channel generates an error interrupt request
5 EEI5	Enable Error Interrupt 5 0 The error signal for corresponding channel does not generate an error interrupt 1 The assertion of the error signal for corresponding channel generates an error interrupt request
4 EEI4	Enable Error Interrupt 4 0 The error signal for corresponding channel does not generate an error interrupt 1 The assertion of the error signal for corresponding channel generates an error interrupt request
3 EEI3	Enable Error Interrupt 3 0 The error signal for corresponding channel does not generate an error interrupt 1 The assertion of the error signal for corresponding channel generates an error interrupt request
2 EEI2	Enable Error Interrupt 2

Table continues on the next page...

DMA_EEI field descriptions (continued)

Field	Description
	0 The error signal for corresponding channel does not generate an error interrupt 1 The assertion of the error signal for corresponding channel generates an error interrupt request
1 EEI1	Enable Error Interrupt 1 0 The error signal for corresponding channel does not generate an error interrupt 1 The assertion of the error signal for corresponding channel generates an error interrupt request
0 EEI0	Enable Error Interrupt 0 0 The error signal for corresponding channel does not generate an error interrupt 1 The assertion of the error signal for corresponding channel generates an error interrupt request

21.3.5 Clear Enable Error Interrupt Register (DMA_CEEI)

The CEEI provides a simple memory-mapped mechanism to clear a given bit in the EEI to disable the error interrupt for a given channel. The data value on a register write causes the corresponding bit in the EEI to be cleared. Setting the CAEE bit provides a global clear function, forcing the EEI contents to be cleared, disabling all DMA request inputs. If the NOP bit is set, the command is ignored. This allows you to write multiple-byte registers as a 32-bit word. Reads of this register return all zeroes.

Address: DMA_CEEI is 4000_8000h base + 18h offset = 4000_8018h

Bit	7	6	5	4	3	2	1	0
Read	0	0	0		0			
Write	NOP	CAEE	0		CEEI			
Reset	0	0	0	0	0	0	0	0

DMA_CEEI field descriptions

Field	Description
7 NOP	0 Normal operation 1 No operation, ignore the other bits in this register
6 CAEE	Clear All Enable Error Interrupts 0 Clear only the EEI bit specified in the CEEI field 1 Clear all bits in EEI
5-4 Reserved	This field is reserved.
3-0 CEEI	Clear Enable Error Interrupt Clears the corresponding bit in EEI

21.3.6 Set Enable Error Interrupt Register (DMA_SEEI)

The SEEI provides a simple memory-mapped mechanism to set a given bit in the EEI to enable the error interrupt for a given channel. The data value on a register write causes the corresponding bit in the EEI to be set. Setting the SAEE bit provides a global set function, forcing the entire EEI contents to be set. If the NOP bit is set, the command is ignored. This allows you to write multiple-byte registers as a 32-bit word. Reads of this register return all zeroes.

Address: DMA_SEEI is 4000_8000h base + 19h offset = 4000_8019h

Bit	7	6	5	4	3	2	1	0
Read	0	0			0			
Write	NOP	SAEE	0		SEEI			
Reset	0	0	0	0	0	0	0	0

DMA_SEEI field descriptions

Field	Description
7 NOP	0 Normal operation 1 No operation, ignore the other bits in this register
6 SAEE	Sets All Enable Error Interrupts 0 Set only the EEI bit specified in the SEEI field. 1 Sets all bits in EEI
5-4 Reserved	This field is reserved.
3-0 SEEI	Set Enable Error Interrupt Sets the corresponding bit in EEI

21.3.7 Clear Enable Request Register (DMA_CERQ)

The CERQ provides a simple memory-mapped mechanism to clear a given bit in the ERQ to disable the DMA request for a given channel. The data value on a register write causes the corresponding bit in the ERQ to be cleared. Setting the CAER bit provides a global clear function, forcing the entire contents of the ERQ to be cleared, disabling all DMA request inputs. If NOP is set, the command is ignored. This allows you to write multiple-byte registers as a 32-bit word. Reads of this register return all zeroes.

Address: DMA_CERQ is 4000_8000h base + 1Ah offset = 4000_801Ah

Bit	7	6	5	4	3	2	1	0
Read	0	0			0			
Write	NOP	CAER	0		CERQ			
Reset	0	0	0	0	0	0	0	0

DMA_CERQ field descriptions

Field	Description
7 NOP	0 Normal operation 1 No operation, ignore the other bits in this register
6 CAER	Clear All Enable Requests 0 Clear only the ERQ bit specified in the CERQ field 1 Clear all bits in ERQ
5-4 Reserved	This field is reserved.
3-0 CERQ	Clear Enable Request Clears the corresponding bit in ERQ

21.3.8 Set Enable Request Register (DMA_SERQ)

The SERQ provides a simple memory-mapped mechanism to set a given bit in the ERQ to enable the DMA request for a given channel. The data value on a register write causes the corresponding bit in the ERQ to be set. Setting the SAER bit provides a global set function, forcing the entire contents of ERQ to be set. If the NOP bit is set, the command is ignored. This allows you to write multiple-byte registers as a 32-bit word. Reads of this register return all zeroes.

Address: DMA_SERQ is 4000_8000h base + 1Bh offset = 4000_801Bh

Bit	7	6	5	4	3	2	1	0
Read	0	0			0			
Write	NOP	SAER	0		SERQ			
Reset	0	0	0	0	0	0	0	0

DMA_SERQ field descriptions

Field	Description
7 NOP	0 Normal operation 1 No operation, ignore the other bits in this register
6 SAER	Set All Enable Requests 0 Set only the ERQ bit specified in the SERQ field 1 Set all bits in ERQ
5-4 Reserved	This field is reserved.
3-0 SERQ	Set enable request Sets the corresponding bit in ERQ

21.3.9 Clear DONE Status Bit Register (DMA_CDNE)

The CDNE provides a simple memory-mapped mechanism to clear the DONE bit in the TCD of the given channel. The data value on a register write causes the DONE bit in the corresponding transfer control descriptor to be cleared. Setting the CADN bit provides a global clear function, forcing all DONE bits to be cleared. If the NOP bit is set, the command is ignored. This allows you to write multiple-byte registers as a 32-bit word. Reads of this register return all zeroes.

Address: DMA_CDNE is 4000_8000h base + 1Ch offset = 4000_801Ch

Bit	7	6	5	4	3	2	1	0
Read	0	0			0			
Write	NOP	CADN	0		CDNE			
Reset	0	0	0	0	0	0	0	0

DMA_CDNE field descriptions

Field	Description
7 NOP	0 Normal operation 1 No operation, ignore the other bits in this register
6 CADN	Clears All DONE Bits 0 Clears only the TCDn_CSR[DONE] bit specified in the CDNE field 1 Clears all bits in TCDn_CSR[DONE]
5-4 Reserved	This field is reserved.
3-0 CDNE	Clear DONE Bit Clears the corresponding bit in TCDn_CSR[DONE]

21.3.10 Set START Bit Register (DMA_SSRT)

The SSRT provides a simple memory-mapped mechanism to set the START bit in the TCD of the given channel. The data value on a register write causes the START bit in the corresponding transfer control descriptor to be set. Setting the SAST bit provides a global set function, forcing all START bits to be set. If the NOP bit is set, the command is ignored. This allows you to write multiple-byte registers as a 32-bit word. Reads of this register return all zeroes.

Address: DMA_SSRT is 4000_8000h base + 1Dh offset = 4000_801Dh

Bit	7	6	5	4	3	2	1	0
Read	0	0			0			
Write	NOP	SAST	0		SSRT			
Reset	0	0	0	0	0	0	0	0

DMA_SSRT field descriptions

Field	Description
7 NOP	0 Normal operation 1 No operation, ignore the other bits in this register
6 SAST	Set All START Bits (activates all channels) 0 Set only the TCDn_CSR[START] bit specified in the SSRT field 1 Set all bits in TCDn_CSR[START]
5-4 Reserved	This field is reserved.
3-0 SSRT	Set START Bit Sets the corresponding bit in TCDn_CSR[START]

21.3.11 Clear Error Register (DMA_CERR)

The CERR provides a simple memory-mapped mechanism to clear a given bit in the ERR to disable the error condition flag for a given channel. The given value on a register write causes the corresponding bit in the ERR to be cleared. Setting the CAEI bit provides a global clear function, forcing the ERR contents to be cleared, clearing all channel error indicators. If the NOP bit is set, the command is ignored. This allows you to write multiple-byte registers as a 32-bit word. Reads of this register return all zeroes.

Address: DMA_CERR is 4000_8000h base + 1Eh offset = 4000_801Eh

Bit	7	6	5	4	3	2	1	0
Read	0	0			0			
Write	NOP	CAEI	0		CERR			
Reset	0	0	0	0	0	0	0	0

DMA_CERR field descriptions

Field	Description
7 NOP	0 Normal operation 1 No operation, ignore the other bits in this register
6 CAEI	Clear All Error Indicators 0 Clear only the ERR bit specified in the CERR field 1 Clear all bits in ERR
5-4 Reserved	This field is reserved.
3-0 CERR	Clear Error Indicator Clears the corresponding bit in ERR

21.3.12 Clear Interrupt Request Register (DMA_CINT)

The CINT provides a simple, memory-mapped mechanism to clear a given bit in the INT to disable the interrupt request for a given channel. The given value on a register write causes the corresponding bit in the INT to be cleared. Setting the CAIR bit provides a global clear function, forcing the entire contents of the INT to be cleared, disabling all DMA interrupt requests. If the NOP bit is set, the command is ignored. This allows you to write multiple-byte registers as a 32-bit word. Reads of this register return all zeroes.

Address: DMA_CINT is 4000_8000h base + 1Fh offset = 4000_801Fh

Bit	7	6	5	4	3	2	1	0
Read	0	0			0			
Write	NOP	CAIR	0		CINT			
Reset	0	0	0	0	0	0	0	0

DMA_CINT field descriptions

Field	Description
7 NOP	0 Normal operation 1 No operation, ignore the other bits in this register
6 CAIR	Clear All Interrupt Requests 0 Clear only the INT bit specified in the CINT field 1 Clear all bits in INT
5-4 Reserved	This field is reserved.
3-0 CINT	Clear Interrupt Request Clears the corresponding bit in INT

21.3.13 Interrupt Request Register (DMA_INT)

The INT register provides a bit map for the 16 channels signaling the presence of an interrupt request for each channel. Depending on the appropriate bit setting in the transfer-control descriptors, the eDMA engine generates an interrupt on data transfer completion. The outputs of this register are directly routed to the interrupt controller (INTC). During the interrupt-service routine associated with any given channel, it is the software's responsibility to clear the appropriate bit, negating the interrupt request. Typically, a write to the CINT register in the interrupt service routine is used for this purpose.

memory map/register definition

The state of any given channel’s interrupt request is directly affected by writes to this register; it is also affected by writes to the CINT register. On writes to INT, a 1 in any bit position clears the corresponding channel’s interrupt request. A zero in any bit position has no affect on the corresponding channel’s current interrupt status. The CINT register is provided so the interrupt request for a single channel can easily be cleared without the need to perform a read-modify-write sequence to the INT register.

Address: DMA_INT is 4000_8000h base + 24h offset = 4000_8024h

Bit	31	30	29	28	27	26	25	24	23	22	21	20	19	18	17	16
R	0															
W																
Reset	0	0	0	0	0	0	0	0	0	0	0	0	0	0	0	0
Bit	15	14	13	12	11	10	9	8	7	6	5	4	3	2	1	0
R	INT15	INT14	INT13	INT12	INT11	INT10	INT9	INT8	INT7	INT6	INT5	INT4	INT3	INT2	INT1	INT0
W	w1c	w1c	w1c	w1c	w1c	w1c	w1c	w1c	w1c	w1c	w1c	w1c	w1c	w1c	w1c	w1c
Reset	0	0	0	0	0	0	0	0	0	0	0	0	0	0	0	0

DMA_INT field descriptions

Field	Description
31–16 Reserved	This read-only field is reserved and always has the value zero.
15 INT15	Interrupt Request 15 0 The interrupt request for corresponding channel is cleared 1 The interrupt request for corresponding channel is active
14 INT14	Interrupt Request 14 0 The interrupt request for corresponding channel is cleared 1 The interrupt request for corresponding channel is active
13 INT13	Interrupt Request 13 0 The interrupt request for corresponding channel is cleared 1 The interrupt request for corresponding channel is active
12 INT12	Interrupt Request 12 0 The interrupt request for corresponding channel is cleared 1 The interrupt request for corresponding channel is active
11 INT11	Interrupt Request 11

Table continues on the next page...

DMA_INT field descriptions (continued)

Field	Description
	0 The interrupt request for corresponding channel is cleared 1 The interrupt request for corresponding channel is active
10 INT10	Interrupt Request 10 0 The interrupt request for corresponding channel is cleared 1 The interrupt request for corresponding channel is active
9 INT9	Interrupt Request 9 0 The interrupt request for corresponding channel is cleared 1 The interrupt request for corresponding channel is active
8 INT8	Interrupt Request 8 0 The interrupt request for corresponding channel is cleared 1 The interrupt request for corresponding channel is active
7 INT7	Interrupt Request 7 0 The interrupt request for corresponding channel is cleared 1 The interrupt request for corresponding channel is active
6 INT6	Interrupt Request 6 0 The interrupt request for corresponding channel is cleared 1 The interrupt request for corresponding channel is active
5 INT5	Interrupt Request 5 0 The interrupt request for corresponding channel is cleared 1 The interrupt request for corresponding channel is active
4 INT4	Interrupt Request 4 0 The interrupt request for corresponding channel is cleared 1 The interrupt request for corresponding channel is active
3 INT3	Interrupt Request 3 0 The interrupt request for corresponding channel is cleared 1 The interrupt request for corresponding channel is active
2 INT2	Interrupt Request 2 0 The interrupt request for corresponding channel is cleared 1 The interrupt request for corresponding channel is active
1 INT1	Interrupt Request 1 0 The interrupt request for corresponding channel is cleared 1 The interrupt request for corresponding channel is active
0 INT0	Interrupt Request 0 0 The interrupt request for corresponding channel is cleared 1 The interrupt request for corresponding channel is active

21.3.14 Error Register (DMA_ERR)

The ERR provides a bit map for the 16 channels, signaling the presence of an error for each channel. The eDMA engine signals the occurrence of an error condition by setting the appropriate bit in this register. The outputs of this register are enabled by the contents of the EEI, and then routed to the interrupt controller. During the execution of the interrupt-service routine associated with any DMA errors, it is software’s responsibility to clear the appropriate bit, negating the error-interrupt request. Typically, a write to the CERR in the interrupt-service routine is used for this purpose. The normal DMA channel completion indicators (setting the transfer control descriptor DONE flag and the possible assertion of an interrupt request) are not affected when an error is detected.

The contents of this register can also be polled because a non-zero value indicates the presence of a channel error regardless of the state of the EEI. The state of any given channel’s error indicators is affected by writes to this register; it is also affected by writes to the CERR. On writes to the ERR, a one in any bit position clears the corresponding channel’s error status. A zero in any bit position has no affect on the corresponding channel’s current error status. The CERR is provided so the error indicator for a single channel can easily be cleared.

Address: DMA_ERR is 4000_8000h base + 2Ch offset = 4000_802Ch

Bit	31	30	29	28	27	26	25	24		23	22	21	20	19	18	17	16
R	0																
W																	
Reset	0	0	0	0	0	0	0	0		0	0	0	0	0	0	0	0
Bit	15	14	13	12	11	10	9	8		7	6	5	4	3	2	1	0
R	ERR15	ERR14	ERR13	ERR12	ERR11	ERR10	ERR9	ERR8		ERR7	ERR6	ERR5	ERR4	ERR3	ERR2	ERR1	ERR0
W	w1c	w1c	w1c	w1c	w1c	w1c	w1c	w1c		w1c	w1c	w1c	w1c	w1c	w1c	w1c	w1c
Reset	0	0	0	0	0	0	0	0		0	0	0	0	0	0	0	0

DMA_ERR field descriptions

Field	Description
31–16 Reserved	This read-only field is reserved and always has the value zero.

Table continues on the next page...

DMA_ERR field descriptions (continued)

Field	Description
15 ERR15	Error In Channel 15 0 An error in the corresponding channel has not occurred 1 An error in the corresponding channel has occurred
14 ERR14	Error In Channel 14 0 An error in the corresponding channel has not occurred 1 An error in the corresponding channel has occurred
13 ERR13	Error In Channel 13 0 An error in the corresponding channel has not occurred 1 An error in the corresponding channel has occurred
12 ERR12	Error In Channel 12 0 An error in the corresponding channel has not occurred 1 An error in the corresponding channel has occurred
11 ERR11	Error In Channel 11 0 An error in the corresponding channel has not occurred 1 An error in the corresponding channel has occurred
10 ERR10	Error In Channel 10 0 An error in the corresponding channel has not occurred 1 An error in the corresponding channel has occurred
9 ERR9	Error In Channel 9 0 An error in the corresponding channel has not occurred 1 An error in the corresponding channel has occurred
8 ERR8	Error In Channel 8 0 An error in the corresponding channel has not occurred 1 An error in the corresponding channel has occurred
7 ERR7	Error In Channel 7 0 An error in the corresponding channel has not occurred 1 An error in the corresponding channel has occurred
6 ERR6	Error In Channel 6 0 An error in the corresponding channel has not occurred 1 An error in the corresponding channel has occurred
5 ERR5	Error In Channel 5 0 An error in the corresponding channel has not occurred 1 An error in the corresponding channel has occurred
4 ERR4	Error In Channel 4

Table continues on the next page...

DMA_ERR field descriptions (continued)

Field	Description
	0 An error in the corresponding channel has not occurred 1 An error in the corresponding channel has occurred
3 ERR3	Error In Channel 3 0 An error in the corresponding channel has not occurred 1 An error in the corresponding channel has occurred
2 ERR2	Error In Channel 2 0 An error in the corresponding channel has not occurred 1 An error in the corresponding channel has occurred
1 ERR1	Error In Channel 1 0 An error in the corresponding channel has not occurred 1 An error in the corresponding channel has occurred
0 ERR0	Error In Channel 0 0 An error in the corresponding channel has not occurred 1 An error in the corresponding channel has occurred

21.3.15 Hardware Request Status Register (DMA_HRS)

The HRS provides a bit map for the DMA channels, signaling the presence of a hardware request for each channel. The hardware request status bits reflect the current state of the register and qualified (via the ERQ fields) DMA request signals as seen by the DMA's arbitration logic. This view into the hardware request signals may be used for debug purposes.

NOTE

These bits reflect the state of the request as seen by the arbitration logic. Therefore, this status is affected by the ERQ bits.

Address: DMA_HRS is 4000_8000h base + 34h offset = 4000_8034h

Bit	31	30	29	28	27	26	25	24	23	22	21	20	19	18	17	16	15	14	13	12	11	10	9	8	7	6	5	4	3	2	1	0		
R	0																HRS15	HRS14	HRS13	HRS12	HRS11	HRS10	HRS9	HRS8	HRS7	HRS6	HRS5	HRS4	HRS3	HRS2	HRS1	HRS0		
W	0																																	
Reset	0	0	0	0	0	0	0	0	0	0	0	0	0	0	0	0	0	0	0	0	0	0	0	0	0	0	0	0	0	0	0			

DMA_HRS field descriptions

Field	Description
31–16 Reserved	This read-only field is reserved and always has the value zero.
15 HRS15	Hardware Request Status Channel 15 0 A hardware service request for the corresponding channel is not present 1 A hardware service request for the corresponding channel is present
14 HRS14	Hardware Request Status Channel 14 0 A hardware service request for the corresponding channel is not present 1 A hardware service request for the corresponding channel is present
13 HRS13	Hardware Request Status Channel 13 0 A hardware service request for the corresponding channel is not present 1 A hardware service request for the corresponding channel is present
12 HRS12	Hardware Request Status Channel 12 0 A hardware service request for the corresponding channel is not present 1 A hardware service request for the corresponding channel is present
11 HRS11	Hardware Request Status Channel 11 0 A hardware service request for the corresponding channel is not present 1 A hardware service request for the corresponding channel is present
10 HRS10	Hardware Request Status Channel 10 0 A hardware service request for the corresponding channel is not present 1 A hardware service request for the corresponding channel is present
9 HRS9	Hardware Request Status Channel 9 0 A hardware service request for the corresponding channel is not present 1 A hardware service request for the corresponding channel is present
8 HRS8	Hardware Request Status Channel 8 0 A hardware service request for the corresponding channel is not present 1 A hardware service request for the corresponding channel is present
7 HRS7	Hardware Request Status Channel 7 0 A hardware service request for the corresponding channel is not present 1 A hardware service request for the corresponding channel is present
6 HRS6	Hardware Request Status Channel 6 0 A hardware service request for the corresponding channel is not present 1 A hardware service request for the corresponding channel is present
5 HRS5	Hardware Request Status Channel 5 0 A hardware service request for the corresponding channel is not present 1 A hardware service request for the corresponding channel is present

Table continues on the next page...

DMA_HRS field descriptions (continued)

Field	Description
4 HRS4	Hardware Request Status Channel 4 0 A hardware service request for the corresponding channel is not present 1 A hardware service request for the corresponding channel is present
3 HRS3	Hardware Request Status Channel 3 0 A hardware service request for the corresponding channel is not present 1 A hardware service request for the corresponding channel is present
2 HRS2	Hardware Request Status Channel 2 0 A hardware service request for the corresponding channel is not present 1 A hardware service request for the corresponding channel is present
1 HRS1	Hardware Request Status Channel 1 0 A hardware service request for the corresponding channel is not present 1 A hardware service request for the corresponding channel is present
0 HRS0	Hardware Request Status Channel 0 0 A hardware service request for the corresponding channel is not present 1 A hardware service request for the corresponding channel is present

21.3.16 Channel n Priority Register (DMA_DCHPRIn)

When fixed-priority channel arbitration is enabled ($CR[ERCA] = 0$), the contents of these registers define the unique priorities associated with each channel. The channel priorities are evaluated by numeric value; for example, 0 is the lowest priority, 1 is the next priority, then 2, 3, etc. Software must program the channel priorities with unique values. Otherwise, a configuration error is reported. The range of the priority value is limited to the values of 0 through 15.

Addresses: 4000_8000h base + 100h offset + (1d × n), where n = 0d to 15d

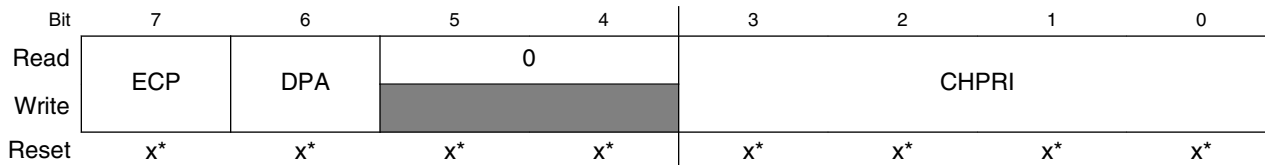

* Notes:

- x = Undefined at reset.

DMA_DCHPRIn field descriptions

Field	Description
7 ECP	Enable Channel Preemption

Table continues on the next page...

DMA_DCHPRIn field descriptions (continued)

Field	Description
	0 Channel n cannot be suspended by a higher priority channel's service request 1 Channel n can be temporarily suspended by the service request of a higher priority channel
6 DPA	Disable Preempt Ability 0 Channel n can suspend a lower priority channel 1 Channel n cannot suspend any channel, regardless of channel priority
5-4 Reserved	This read-only field is reserved and always has the value zero.
3-0 CHPRI	Channel n Arbitration Priority Channel priority when fixed-priority arbitration is enabled NOTE: Reset value for the channel priority fields, CHPRI, is equal to the corresponding channel number for each priority register, i.e., DCHPRI15[CHPRI] equals 0b1111.

21.3.17 TCD Source Address (DMA_TCD_SADDR)

Addresses: 4000_8000h base + 1000h offset + (32d × n), where n = 0d to 15d

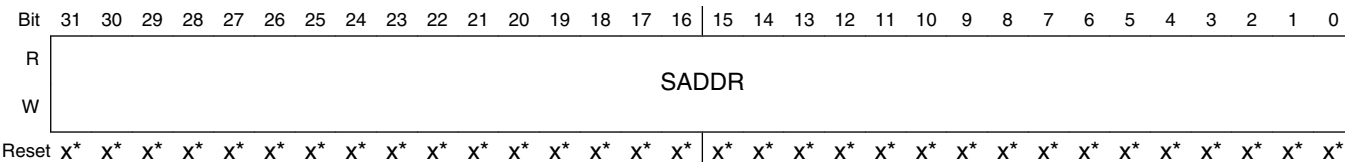

- * Notes:
- x = Undefined at reset.

DMA_TCDn_SADDR field descriptions

Field	Description
31-0 SADDR	Source Address Memory address pointing to the source data.

21.3.18 TCD Signed Source Address Offset (DMA_TCD_SOFF)

Addresses: 4000_8000h base + 1004h offset + (32d × n), where n = 0d to 15d

Bit	15	14	13	12	11	10	9	8	7	6	5	4	3	2	1	0
Read	SOFF															
Write	SOFF															
Reset	x*	x*	x*	x*	x*	x*	x*	x*	x*	x*	x*	x*	x*	x*	x*	x*

* Notes:

- x = Undefined at reset.

DMA_TCDn_SOFF field descriptions

Field	Description
15–0 SOFF	Source address signed offset Sign-extended offset applied to the current source address to form the next-state value as each source read is completed.

21.3.19 TCD Transfer Attributes (DMA_TCD_ATTR)

Addresses: 4000_8000h base + 1006h offset + (32d × n), where n = 0d to 15d

Bit	15	14	13	12	11	10	9	8	7	6	5	4	3	2	1	0
Read	SMOD				SSIZE				DMOD				DSIZE			
Write	SMOD				SSIZE				DMOD				DSIZE			
Reset	x*	x*	x*	x*	x*	x*	x*	x*	x*	x*	x*	x*	x*	x*	x*	x*

* Notes:

- x = Undefined at reset.

DMA_TCDn_ATTR field descriptions

Field	Description
15–11 SMOD	Source Address Modulo. 0 Source address modulo feature is disabled ≠0 This value defines a specific address range specified to be the value after SADDR + SOFF calculation is performed or the original register value. The setting of this field provides the ability to implement a circular data queue easily. For data queues requiring power-of-2 size bytes, the queue should start at a 0-modulo-size address and the SMOD field should be set to the appropriate value for the queue, freezing the desired number of upper address bits. The value programmed into this field specifies the number of lower address bits allowed to change. For a circular queue application, the SOFF is typically set to the transfer size to implement post-increment addressing with the SMOD function constraining the addresses to a 0-modulo-size range.

Table continues on the next page...

DMA_TCDn_ATTR field descriptions (continued)

Field	Description
10–8 SSIZE	Source data transfer size The attempted use of a Reserved encoding causes a configuration error. 000 8-bit 001 16-bit 010 32-bit 011 Reserved 100 16-byte 101 Reserved 110 Reserved 111 Reserved
7–3 DMOD	Destination Address Modulo See the SMOD definition
2–0 DSIZE	Destination Data Transfer Size See the SSIZE definition

21.3.20 TCD Minor Byte Count (Minor Loop Disabled) (DMA_TCD_NBYTES_MLNO)

TCD word 2's register definition depends on the status of minor loop mapping. If minor loop mapping is disabled ($CR[EMLM] = 0$), TCD word 2 is defined as follows. If minor loop mapping is enabled, see the TCD_NBYTES_MLOFFNO and TCD_NBYTES_MLOFFYES register descriptions for TCD word 2's register definition.

Addresses: 4000_8000h base + $1008h$ offset + $(32d \times n)$, where $n = 0d$ to $15d$

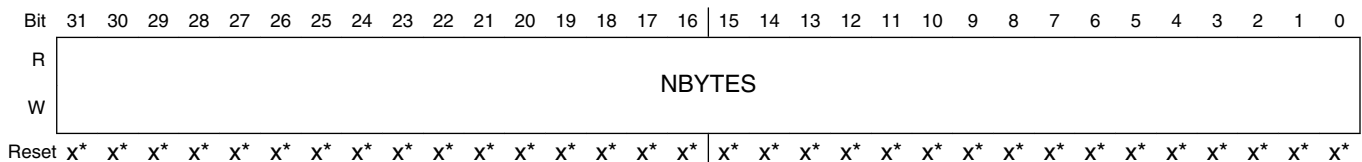

* Notes:

- x = Undefined at reset.

DMA_TCDn_NBYTES_MLNO field descriptions

Field	Description
31–0 NBYTES	Minor Byte Transfer Count Number of bytes to be transferred in each service request of the channel. As a channel activates, the appropriate TCD contents load into the eDMA engine, and the appropriate reads and writes perform until the minor byte transfer count has transferred. This is an indivisible operation and cannot be halted. (Although, it may be stalled by using the bandwidth control field, or via preemption.) After the minor count

DMA_TCDn_NBYTES_MLNO field descriptions (continued)

Field	Description
	<p>is exhausted, the SADDR and DADDR values are written back into the TCD memory, the major iteration count is decremented and restored to the TCD memory. If the major iteration count is completed, additional processing is performed.</p> <p>NOTE: An NBYTES value of 0x0000_0000 is interpreted as a 4 GB transfer.</p>

21.3.21 TCD Signed Minor Loop Offset (Minor Loop Enabled and Offset Disabled) (DMA_TCD_NBYTES_MLOFFNO)

TCD word 2 is defined as follows if:

- Minor loop mapping is enabled (CR[EMLM] = 1) and
- SMLOE = 0 and DMLOE = 0

If minor loop mapping is enabled and SMLOE or DMLOE is set then refer to the TCD_NBYTES_MLOFFYES register description.

Addresses: 4000_8000h base + 1008h offset + (32d × n), where n = 0d to 15d

Bit	31	30	29	28	27	26	25	24	23	22	21	20	19	18	17	16	15	14	13	12	11	10	9	8	7	6	5	4	3	2	1	0
R																	NBYTES															
W	SMLOE	DMLOE																														
Reset	x*	x*	x*	x*	x*	x*	x*	x*	x*	x*	x*	x*	x*	x*	x*	x*	x*	x*	x*	x*	x*	x*	x*	x*	x*	x*	x*	x*	x*	x*	x*	x*

* Notes:

- x = Undefined at reset.

DMA_TCDn_NBYTES_MLOFFNO field descriptions

Field	Description
31 SMLOE	<p>Source Minor Loop Offset Enable</p> <p>Selects whether the minor loop offset is applied to the source address upon minor loop completion.</p> <p>0 The minor loop offset is not applied to the SADDR 1 The minor loop offset is applied to the SADDR</p>
30 DMLOE	<p>Destination Minor Loop Offset enable</p> <p>Selects whether the minor loop offset is applied to the destination address upon minor loop completion.</p> <p>0 The minor loop offset is not applied to the DADDR 1 The minor loop offset is applied to the DADDR</p>
29–0 NBYTES	<p>Minor Byte Transfer Count</p> <p>Number of bytes to be transferred in each service request of the channel.</p>

Table continues on the next page...

DMA_TCDn_NBYTES_MLOFFNO field descriptions (continued)

Field	Description
	As a channel activates, the appropriate TCD contents load into the eDMA engine, and the appropriate reads and writes perform until the minor byte transfer count has transferred. This is an indivisible operation and cannot be halted; although, it may be stalled by using the bandwidth control field, or via preemption. After the minor count is exhausted, the SADDR and DADDR values are written back into the TCD memory, the major iteration count is decremented and restored to the TCD memory. If the major iteration count is completed, additional processing is performed.

21.3.22 TCD Signed Minor Loop Offset (Minor Loop and Offset Enabled) (DMA_TCD_NBYTES_MLOFFYES)

TCD word 2 is defined as follows if:

- Minor loop mapping is enabled (CR[EMLM] = 1) and
- Minor loop offset enabled (SMLOE or DMLOE = 1)

If minor loop mapping is enabled and SMLOE and DMLOE are cleared then refer to the TCD_NBYTES_MLOFFNO register description.

Addresses: 4000_8000h base + 1008h offset + (32d × n), where n = 0d to 15d

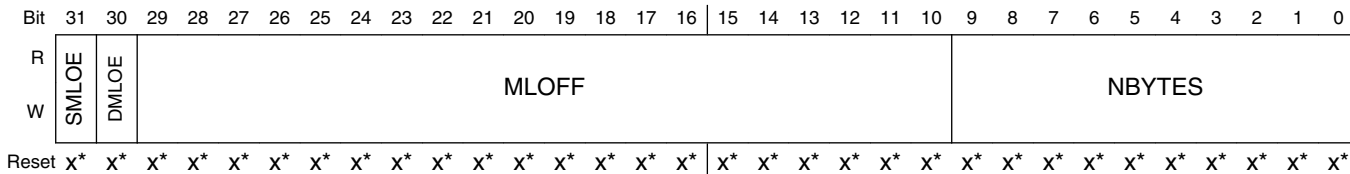

* Notes:

- x = Undefined at reset.

DMA_TCDn_NBYTES_MLOFFYES field descriptions

Field	Description
31 SMLOE	Source Minor Loop Offset Enable Selects whether the minor loop offset is applied to the source address upon minor loop completion. 0 The minor loop offset is not applied to the SADDR 1 The minor loop offset is applied to the SADDR
30 DMLOE	Destination Minor Loop Offset enable Selects whether the minor loop offset is applied to the destination address upon minor loop completion. 0 The minor loop offset is not applied to the DADDR 1 The minor loop offset is applied to the DADDR
29–10 MLOFF	If SMLOE or DMLOE is set, this field represents a sign-extended offset applied to the source or destination address to form the next-state value after the minor loop completes.

Table continues on the next page...

DMA_TCDn_NBYTES_MLOFFYES field descriptions (continued)

Field	Description
9–0 NBYTES	<p>Minor Byte Transfer Count</p> <p>Number of bytes to be transferred in each service request of the channel.</p> <p>As a channel activates, the appropriate TCD contents load into the eDMA engine, and the appropriate reads and writes perform until the minor byte transfer count has transferred. This is an indivisible operation and cannot be halted. (Although, it may be stalled by using the bandwidth control field, or via preemption.) After the minor count is exhausted, the SADDR and DADDR values are written back into the TCD memory, the major iteration count is decremented and restored to the TCD memory. If the major iteration count is completed, additional processing is performed.</p>

21.3.23 TCD Last Source Address Adjustment (DMA_TCD_SLAST)

Addresses: 4000_8000h base + 100Ch offset + (32d × n), where n = 0d to 15d

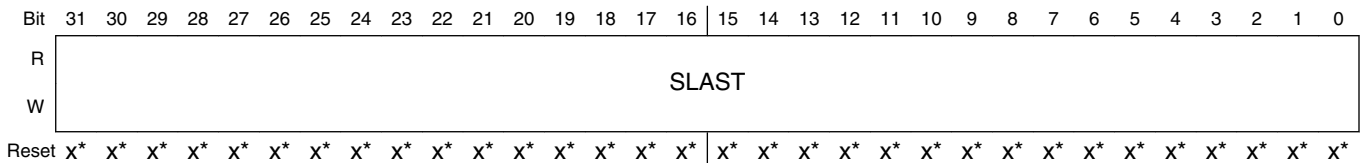

- * Notes:
- x = Undefined at reset.

DMA_TCDn_SLAST field descriptions

Field	Description
31–0 SLAST	<p>Last source Address Adjustment</p> <p>Adjustment value added to the source address at the completion of the major iteration count. This value can be applied to restore the source address to the initial value, or adjust the address to reference the next data structure.</p>

21.3.24 TCD Destination Address (DMA_TCD_DADDR)

Addresses: 4000_8000h base + 1010h offset + (32d × n), where n = 0d to 15d

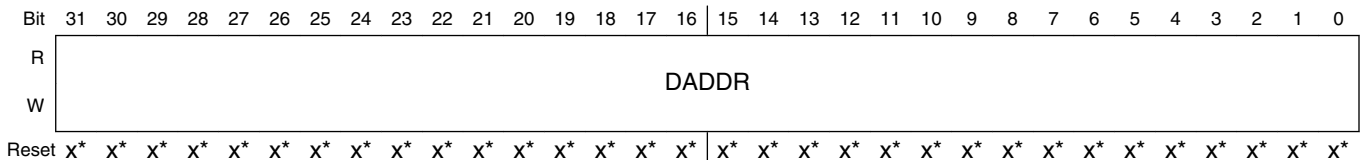

- * Notes:
- x = Undefined at reset.

DMA_TCDn_DADDR field descriptions

Field	Description
31–0 DADDR	Destination Address Memory address pointing to the destination data.

21.3.25 TCD Signed Destination Address Offset (DMA_TCD_DOFF)

Addresses: 4000_8000h base + 1014h offset + (32d × n), where n = 0d to 15d

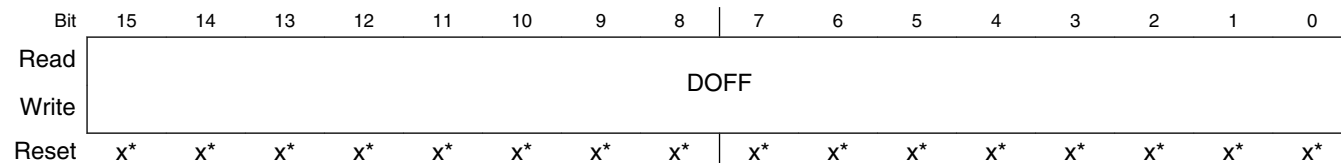

* Notes:

- x = Undefined at reset.

DMA_TCDn_DOFF field descriptions

Field	Description
15–0 DOFF	Destination Address Signed offset Sign-extended offset applied to the current destination address to form the next-state value as each destination write is completed.

21.3.26 TCD Current Minor Loop Link, Major Loop Count (Channel Linking Enabled) (DMA_TCD_CITER_ELINKYES)

If TCDn_CITER[ELINK] is set, the TCDn_CITER register is defined as follows.

Addresses: 4000_8000h base + 1016h offset + (32d × n), where n = 0d to 15d

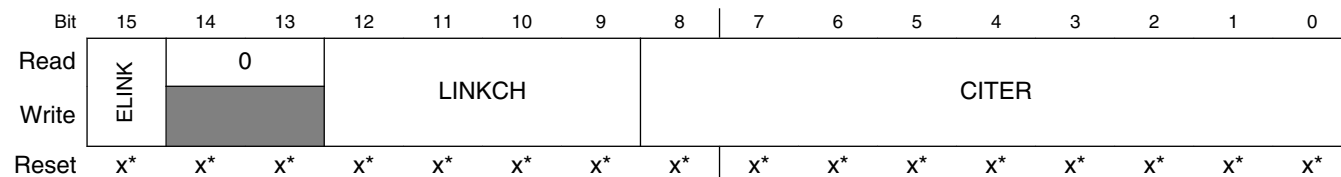

* Notes:

- x = Undefined at reset.

DMA_TCDn_CITER_ELINKYES field descriptions

Field	Description
15 ELINK	<p>Enable channel-to-channel linking on minor-loop complete</p> <p>As the channel completes the minor loop, this flag enables linking to another channel, defined by the LINKCH field. The link target channel initiates a channel service request via an internal mechanism that sets the TCDn_CSR[START] bit of the specified channel.</p> <p>If channel linking is disabled, the CITER value is extended to 15 bits in place of a link channel number. If the major loop is exhausted, this link mechanism is suppressed in favor of the MAJORELINK channel linking.</p> <p>NOTE: This bit must be equal to the BITER[ELINK] bit. Otherwise, a configuration error is reported.</p> <p>0 The channel-to-channel linking is disabled 1 The channel-to-channel linking is enabled</p>
14–13 Reserved	This read-only field is reserved and always has the value zero.
12–9 LINKCH	<p>Link Channel Number</p> <p>If channel-to-channel linking is enabled (ELINK = 1), then after the minor loop is exhausted, the eDMA engine initiates a channel service request to the channel defined by these four bits by setting that channel's TCDn_CSR[START] bit.</p>
8–0 CITER	<p>Current Major Iteration Count</p> <p>This 9-bit (ELINK = 1) or 15-bit (ELINK = 0) count represents the current major loop count for the channel. It is decremented each time the minor loop is completed and updated in the transfer control descriptor memory. After the major iteration count is exhausted, the channel performs a number of operations (e.g., final source and destination address calculations), optionally generating an interrupt to signal channel completion before reloading the CITER field from the beginning iteration count (BITER) field.</p> <p>NOTE: When the CITER field is initially loaded by software, it must be set to the same value as that contained in the BITER field.</p> <p>NOTE: If the channel is configured to execute a single service request, the initial values of BITER and CITER should be 0x0001.</p>

21.3.27 TCD Current Minor Loop Link, Major Loop Count (Channel Linking Disabled) (DMA_TCD_CITER_ELINKNO)

If TCDn_CITER[ELINK] is cleared, the TCDn_CITER register is defined as follows.

Addresses: 4000_8000h base + 1016h offset + (32d × n), where n = 0d to 15d

Bit	15	14	13	12	11	10	9	8	7	6	5	4	3	2	1	0
Read	ELINK	CITER														
Write																
Reset	x*	x*	x*	x*	x*	x*	x*	x*	x*	x*	x*	x*	x*	x*	x*	x*

* Notes:

- x = Undefined at reset.

DMA_TCDn_CITER_ELINKNO field descriptions

Field	Description
15 ELINK	<p>Enable channel-to-channel linking on minor-loop complete</p> <p>As the channel completes the minor loop, this flag enables linking to another channel, defined by the LINKCH field. The link target channel initiates a channel service request via an internal mechanism that sets the TCDn_CSR[START] bit of the specified channel.</p> <p>If channel linking is disabled, the CITER value is extended to 15 bits in place of a link channel number. If the major loop is exhausted, this link mechanism is suppressed in favor of the MAJORELINK channel linking.</p> <p>NOTE: This bit must be equal to the BITER[ELINK] bit. Otherwise, a configuration error is reported.</p> <p>0 The channel-to-channel linking is disabled 1 The channel-to-channel linking is enabled</p>
14–0 CITER	<p>Current Major Iteration Count</p> <p>This 9-bit (ELINK = 1) or 15-bit (ELINK = 0) count represents the current major loop count for the channel. It is decremented each time the minor loop is completed and updated in the transfer control descriptor memory. After the major iteration count is exhausted, the channel performs a number of operations (e.g., final source and destination address calculations), optionally generating an interrupt to signal channel completion before reloading the CITER field from the beginning iteration count (BITER) field.</p> <p>NOTE: When the CITER field is initially loaded by software, it must be set to the same value as that contained in the BITER field.</p> <p>NOTE: If the channel is configured to execute a single service request, the initial values of BITER and CITER should be 0x0001.</p>

21.3.28 TCD Last Destination Address Adjustment/Scatter Gather Address (DMA_TCD_DLASTSGA)

Addresses: 4000_8000h base + 1018h offset + (32d × n), where n = 0d to 15d

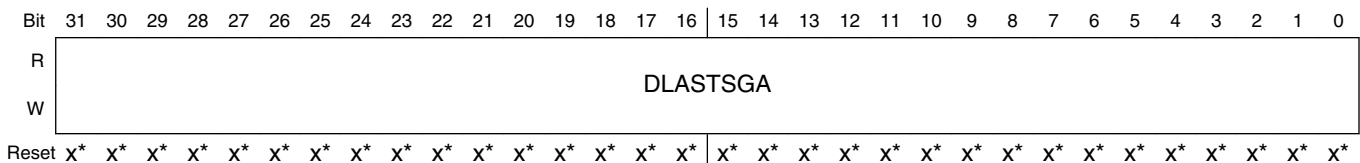

* Notes:

- x = Undefined at reset.

DMA_TCDn_DLASTSGA field descriptions

Field	Description
31–0 DLASTSGA	<p>Destination last address adjustment or the memory address for the next transfer control descriptor to be loaded into this channel (scatter/gather).</p> <p>If (TCDn_CSR[ESG] = 0) then</p> <ul style="list-style-type: none"> • Adjustment value added to the destination address at the completion of the major iteration count. This value can apply to restore the destination address to the initial value or adjust the address to reference the next data structure.

DMA_TCDn_DLASTSGA field descriptions (continued)

Field	Description
	<p>else</p> <ul style="list-style-type: none"> This address points to the beginning of a 0-modulo-32-byte region containing the next transfer control descriptor to be loaded into this channel. This channel reload is performed as the major iteration count completes. The scatter/gather address must be 0-modulo-32-byte, else a configuration error is reported.

21.3.29 TCD Control and Status (DMA_TCD_CSR)

Addresses: 4000_8000h base + 101Ch offset + (32d × n), where n = 0d to 15d

Bit	15	14	13	12	11	10	9	8	7	6	5	4	3	2	1	0
Read	BWC		0		MAJORLINKCH				DONE	ACTIVE	MAJORELINK	ESG	DREQ	INTHALF	INTMAJOR	START
Write																
Reset	x*	x*	x*	x*	x*	x*	x*	x*	x*	x*	x*	x*	x*	x*	x*	x*

* Notes:

- x = Undefined at reset.

DMA_TCDn_CSR field descriptions

Field	Description
15–14 BWC	<p>Bandwidth Control</p> <p>Throttles the amount of bus bandwidth consumed by the eDMA. In general, as the eDMA processes the minor loop, it continuously generates read/write sequences until the minor count is exhausted. This field forces the eDMA to stall after the completion of each read/write access to control the bus request bandwidth seen by the crossbar switch.</p> <p>NOTE: If the source and destination sizes are equal, this field is ignored between the first and second transfers and after the last write of each minor loop. This behavior is a side effect of reducing start-up latency.</p> <p>00 No eDMA engine stalls 01 Reserved 10 eDMA engine stalls for 4 cycles after each r/w 11 eDMA engine stalls for 8 cycles after each r/w</p>
13–12 Reserved	This read-only field is reserved and always has the value zero.
11–8 MAJORLINKCH	<p>Link Channel Number</p> <p>If (MAJORELINK = 0) then</p> <ul style="list-style-type: none"> No channel-to-channel linking (or chaining) is performed after the major loop counter is exhausted. <p>else</p>

Table continues on the next page...

DMA_TCDn_CSR field descriptions (continued)

Field	Description
	<ul style="list-style-type: none"> After the major loop counter is exhausted, the eDMA engine initiates a channel service request at the channel defined by these six bits by setting that channel's TCDn_CSR[START] bit.
7 DONE	<p>Channel Done</p> <p>This flag indicates the eDMA has completed the major loop. The eDMA engine sets it as the CITER count reaches zero; The software clears it, or the hardware when the channel is activated.</p> <p>NOTE: This bit must be cleared to write the MAJORELINK or ESG bits.</p>
6 ACTIVE	<p>Channel Active</p> <p>This flag signals the channel is currently in execution. It is set when channel service begins, and the eDMA clears it as the minor loop completes or if any error condition is detected. This bit resets to zero.</p>
5 MAJORELINK	<p>Enable channel-to-channel linking on major loop complete</p> <p>As the channel completes the major loop, this flag enables the linking to another channel, defined by MAJORLINKCH. The link target channel initiates a channel service request via an internal mechanism that sets the TCDn_CSR[START] bit of the specified channel.</p> <p>NOTE: To support the dynamic linking coherency model, this field is forced to zero when written to while the TCDn_CSR[DONE] bit is set.</p> <p>0 The channel-to-channel linking is disabled 1 The channel-to-channel linking is enabled</p>
4 ESG	<p>Enable Scatter/Gather Processing</p> <p>As the channel completes the major loop, this flag enables scatter/gather processing in the current channel. If enabled, the eDMA engine uses DLASTSGA as a memory pointer to a 0-modulo-32 address containing a 32-byte data structure loaded as the transfer control descriptor into the local memory.</p> <p>NOTE: To support the dynamic scatter/gather coherency model, this field is forced to zero when written to while the TCDn_CSR[DONE] bit is set.</p> <p>0 The current channel's TCD is normal format. 1 The current channel's TCD specifies a scatter gather format. The DLASTSGA field provides a memory pointer to the next TCD to be loaded into this channel after the major loop completes its execution.</p>
3 DREQ	<p>Disable Request</p> <p>If this flag is set, the eDMA hardware automatically clears the corresponding ERQ bit when the current major iteration count reaches zero.</p> <p>0 The channel's ERQ bit is not affected 1 The channel's ERQ bit is cleared when the major loop is complete</p>
2 INTHALF	<p>Enable an interrupt when major counter is half complete.</p> <p>If this flag is set, the channel generates an interrupt request by setting the appropriate bit in the INT register when the current major iteration count reaches the halfway point. Specifically, the comparison performed by the eDMA engine is (CITER == (BITER >> 1)). This halfway point interrupt request is provided to support double-buffered (aka ping-pong) schemes or other types of data movement where the processor needs an early indication of the transfer's progress. If BITER is set, do not use INTHALF. Use INTMAJOR instead.</p>

Table continues on the next page...

DMA_TCDn_CSR field descriptions (continued)

Field	Description
	0 The half-point interrupt is disabled 1 The half-point interrupt is enabled
1 INTMAJOR	Enable an interrupt when major iteration count completes If this flag is set, the channel generates an interrupt request by setting the appropriate bit in the INT when the current major iteration count reaches zero. 0 The end-of-major loop interrupt is disabled 1 The end-of-major loop interrupt is enabled
0 START	Channel Start If this flag is set, the channel is requesting service. The eDMA hardware automatically clears this flag after the channel begins execution. 0 The channel is not explicitly started 1 The channel is explicitly started via a software initiated service request

21.3.30 TCD Beginning Minor Loop Link, Major Loop Count (Channel Linking Enabled) (DMA_TCD_BITER_ELINKYES)

If the TCDn_BITER[ELINK] bit is set, the TCDn_BITER register is defined as follows.

Addresses: 4000_8000h base + 101Eh offset + (32d × n), where n = 0d to 15d

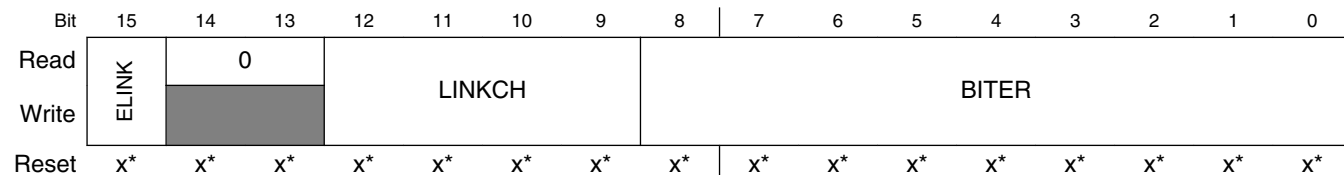

* Notes:

- x = Undefined at reset.

DMA_TCDn_BITER_ELINKYES field descriptions

Field	Description
15 ELINK	Enables channel-to-channel linking on minor loop complete As the channel completes the minor loop, this flag enables the linking to another channel, defined by BITER[LINKCH]. The link target channel initiates a channel service request via an internal mechanism that sets the TCDn_CSR[START] bit of the specified channel. If channel linking disables, the BITER value extends to 15 bits in place of a link channel number. If the major loop is exhausted, this link mechanism is suppressed in favor of the MAJORELINK channel linking. NOTE: When the software loads the TCD, this field must be set equal to the corresponding CITER field. Otherwise, a configuration error is reported. As the major iteration count is exhausted, the contents of this field is reloaded into the CITER field.

Table continues on the next page...

DMA_TCDn_BITER_ELINKYES field descriptions (continued)

Field	Description
	0 The channel-to-channel linking is disabled 1 The channel-to-channel linking is enabled
14–13 Reserved	This read-only field is reserved and always has the value zero.
12–9 LINKCH	Link Channel Number If channel-to-channel linking is enabled (ELINK = 1), then after the minor loop is exhausted, the eDMA engine initiates a channel service request at the channel defined by these four bits by setting that channel's TCDn_CSR[START] bit. NOTE: When the software loads the TCD, this field must be set equal to the corresponding CITER field. Otherwise, a configuration error is reported. As the major iteration count is exhausted, the contents of this field is reloaded into the CITER field.
8–0 BITER	Starting Major Iteration Count As the transfer control descriptor is first loaded by software, this 9-bit (ELINK = 1) or 15-bit (ELINK = 0) field must be equal to the value in the CITER field. As the major iteration count is exhausted, the contents of this field are reloaded into the CITER field. NOTE: When the software loads the TCD, this field must be set equal to the corresponding CITER field. Otherwise, a configuration error is reported. As the major iteration count is exhausted, the contents of this field is reloaded into the CITER field. If the channel is configured to execute a single service request, the initial values of BITER and CITER should be 0x0001.

21.3.31 TCD Beginning Minor Loop Link, Major Loop Count (Channel Linking Disabled) (DMA_TCD_BITER_ELINKNO)

If the TCDn_BITER[ELINK] bit is cleared, the TCDn_BITER register is defined as follows.

Addresses: 4000_8000h base + 101Eh offset + (32d × n), where n = 0d to 15d

Bit	15	14	13	12	11	10	9	8	7	6	5	4	3	2	1	0
Read	ELINK	BITER														
Write																
Reset	x*	x*	x*	x*	x*	x*	x*	x*	x*	x*	x*	x*	x*	x*	x*	x*

* Notes:

- x = Undefined at reset.

DMA_TCDn_BITER_ELINKNO field descriptions

Field	Description
15 ELINK	Enables channel-to-channel linking on minor loop complete As the channel completes the minor loop, this flag enables the linking to another channel, defined by BITER[LINKCH]. The link target channel initiates a channel service request via an internal mechanism that sets the TCDn_CSR[START] bit of the specified channel. If channel linking is disabled, the BITER

Table continues on the next page...

DMA_TCDn_BITER_ELINKNO field descriptions (continued)

Field	Description
	<p>value extends to 15 bits in place of a link channel number. If the major loop is exhausted, this link mechanism is suppressed in favor of the MAJORELINK channel linking.</p> <p>NOTE: When the software loads the TCD, this field must be set equal to the corresponding CITER field. Otherwise, a configuration error is reported. As the major iteration count is exhausted, the contents of this field is reloaded into the CITER field.</p> <p>0 The channel-to-channel linking is disabled 1 The channel-to-channel linking is enabled</p>
14–0 BITER	<p>Starting Major Iteration Count</p> <p>As the transfer control descriptor is first loaded by software, this 9-bit (ELINK = 1) or 15-bit (ELINK = 0) field must be equal to the value in the CITER field. As the major iteration count is exhausted, the contents of this field are reloaded into the CITER field.</p> <p>NOTE: When the software loads the TCD, this field must be set equal to the corresponding CITER field. Otherwise, a configuration error is reported. As the major iteration count is exhausted, the contents of this field is reloaded into the CITER field. If the channel is configured to execute a single service request, the initial values of BITER and CITER should be 0x0001.</p>

21.4 Functional description

21.4.1 eDMA basic data flow

The basic flow of a data transfer can be partitioned into three segments.

As shown in the following diagram, the first segment involves the channel activation:

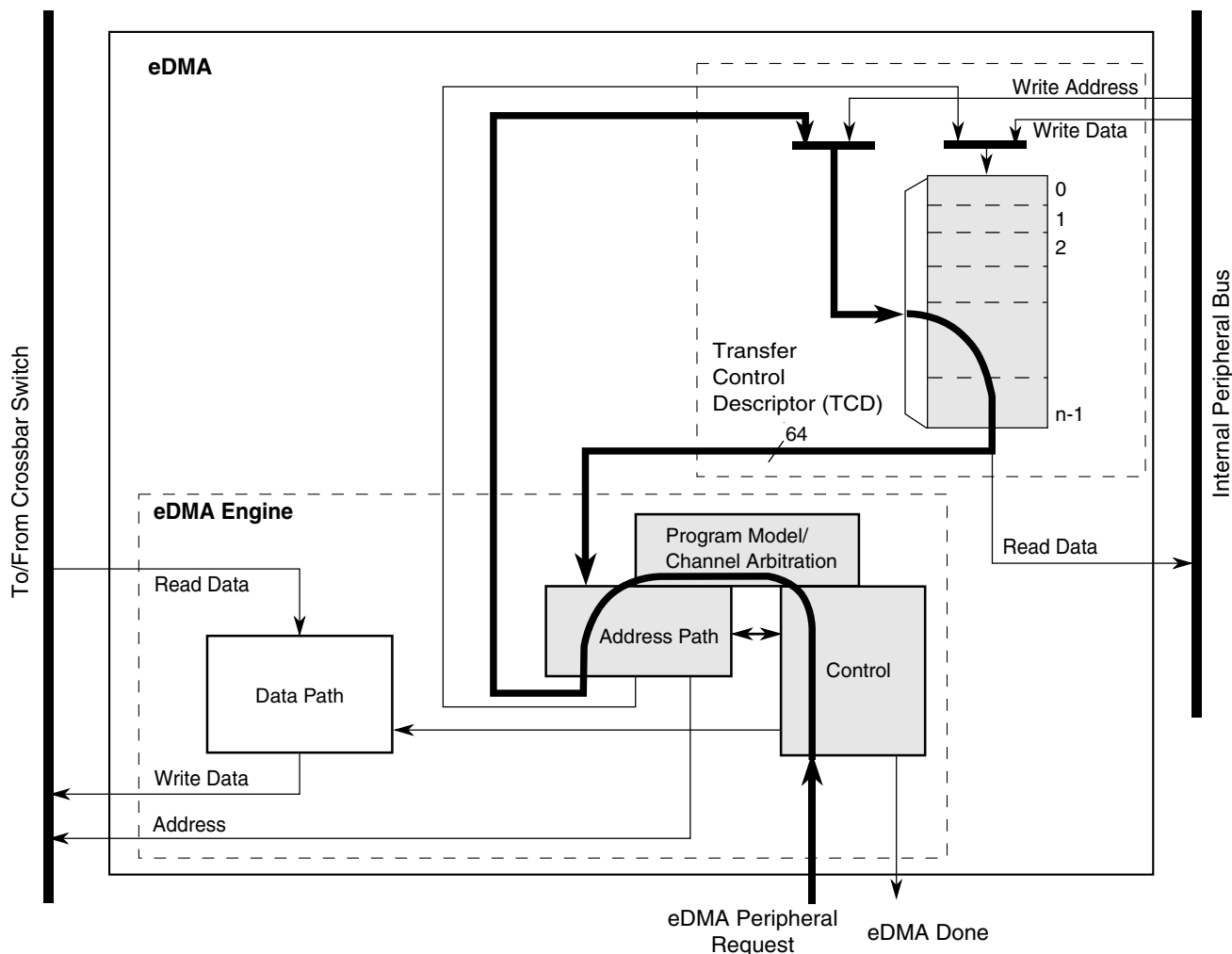

Figure 21-289. eDMA operation, part 1

This example uses the assertion of the eDMA peripheral request signal to request service for channel n . Channel activation via software and the $TCDn_CSR[START]$ bit follows the same basic flow as peripheral requests. The eDMA request input signal is registered internally and then routed through the eDMA engine: first through the control module, then into the program model and channel arbitration. In the next cycle, the channel arbitration performs, using the fixed-priority or round-robin algorithm. After arbitration is complete, the activated channel number is sent through the address path and converted into the required address to access the local memory for $TCDn$. Next, the TCD memory is accessed and the required descriptor read from the local memory and loaded into the eDMA engine address path channel x or y registers. The TCD memory is 64 bits wide to minimize the time needed to fetch the activated channel descriptor and load it into the address path channel x or y registers.

The following diagram illustrates the second part of the basic data flow:

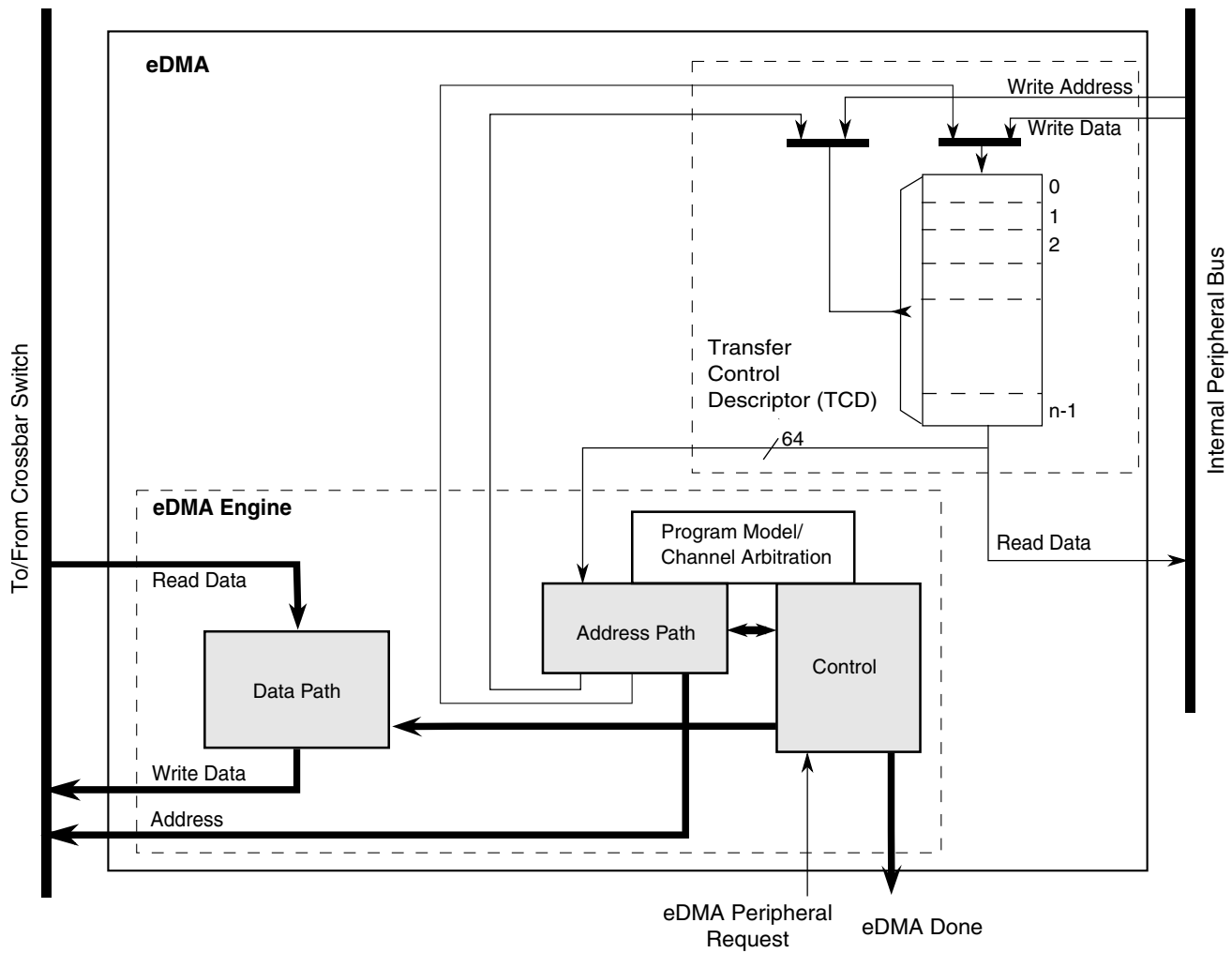

Figure 21-290. eDMA operation, part 2

The modules associated with the data transfer (address path, data path, and control) sequence through the required source reads and destination writes to perform the actual data movement. The source reads are initiated and the fetched data is temporarily stored in the data path block until it is gated onto the internal bus during the destination write. This source read/destination write processing continues until the minor byte count has transferred.

After the minor byte count has moved, the final phase of the basic data flow is performed. In this segment, the address path logic performs the required updates to certain fields in the appropriate TCD, e.g., SADDR, DADDR, CITER. If the major iteration count is exhausted, additional operations are performed. These include the final address adjustments and reloading of the BITER field into the CITER. Assertion of an optional interrupt request also occurs at this time, as does a possible fetch of a new TCD from memory using the scatter/gather address pointer included in the descriptor (if scatter/gather is enabled). The updates to the TCD memory and the assertion of an interrupt request are shown in the following diagram.

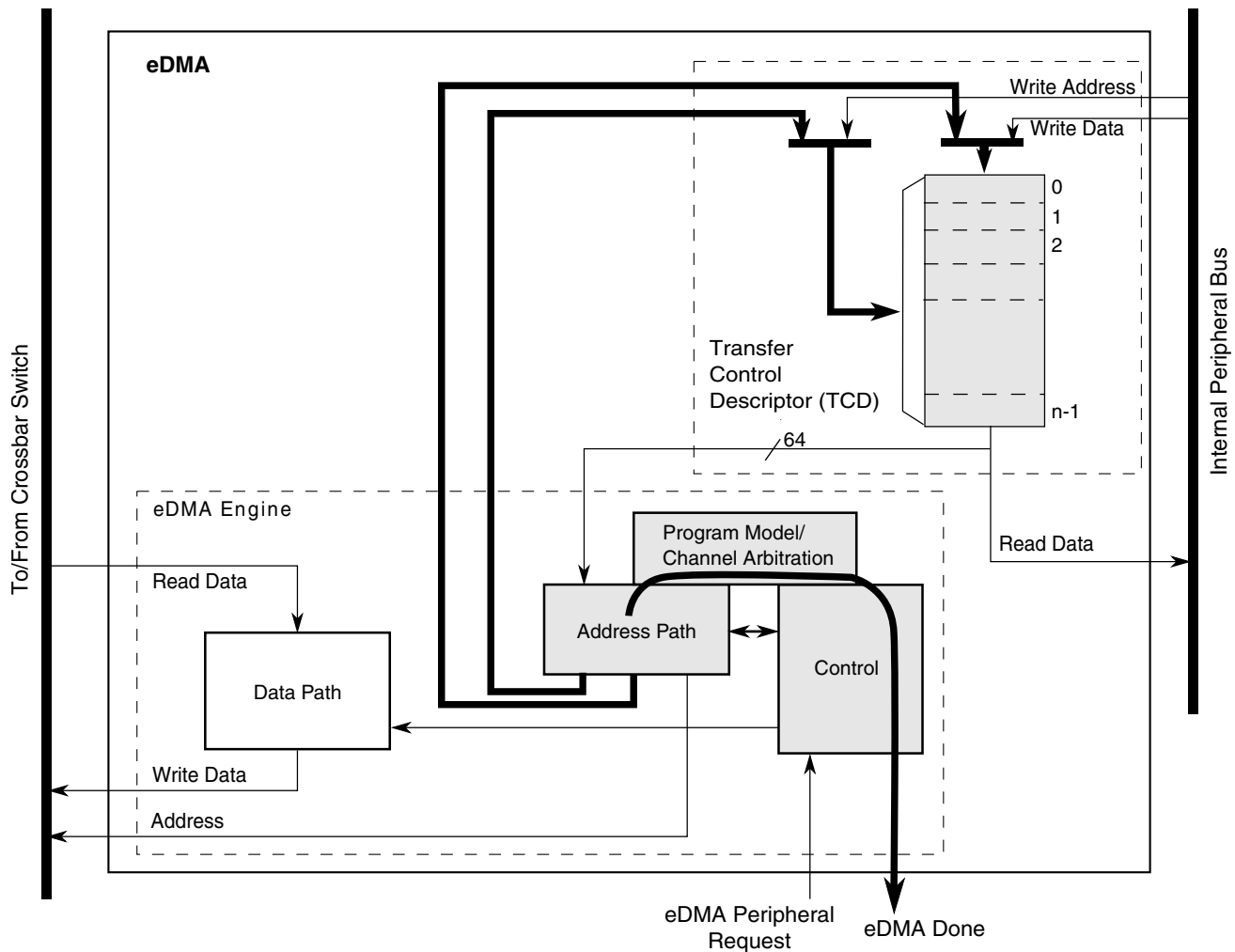

Figure 21-291. eDMA operation, part 3

21.4.2 Error reporting and handling

Channel errors are reported in the ES register and can be caused by:

- A configuration error, which is an illegal setting in the transfer-control descriptor or an illegal priority register setting in Fixed-Arbitration mode, or
- An error termination to a bus master read or write cycle

A configuration error is reported when the starting source or destination address, source or destination offsets, minor loop byte count, or the transfer size represent an inconsistent state. Each of these possible causes are detailed below:

- The addresses and offsets must be aligned on 0-modulo-transfer-size boundaries.
- The minor loop byte count must be a multiple of the source and destination transfer sizes.

- All source reads and destination writes must be configured to the natural boundary of the programmed transfer size respectively.
- In fixed arbitration mode, a configuration error is caused by any two channel priorities being equal. All channel priority levels must be unique when fixed arbitration mode is enabled.
- If a scatter/gather operation is enabled upon channel completion, a configuration error is reported if the scatter/gather address (DLAST_SGA) is not aligned on a 32-byte boundary.
- If minor loop channel linking is enabled upon channel completion, a configuration error is reported when the link is attempted if the TCDn_CITER[E_LINK] bit does not equal the TCDn_BITER[E_LINK] bit.

If enabled, all configuration error conditions, except the scatter/gather and minor-loop link errors, report as the channel activates and asserts an error interrupt request. A scatter/gather configuration error is reported when the scatter/gather operation begins at major loop completion when properly enabled. A minor loop channel link configuration error is reported when the link operation is serviced at minor loop completion.

If a system bus read or write is terminated with an error, the data transfer is stopped and the appropriate bus error flag set. In this case, the state of the channel's transfer control descriptor is updated by the eDMA engine with the current source address, destination address, and current iteration count at the point of the fault. When a system-bus error occurs, the channel terminates after the read or write transaction, which is already pipelined after errant access, has completed. If a bus error occurs on the last read prior to beginning the write sequence, the write executes using the data captured during the bus error. If a bus error occurs on the last write prior to switching to the next read sequence, the read sequence executes before the channel terminates due to the destination bus error.

A transfer may be cancelled by software with the CR[CX] bit. When a cancel transfer request is recognized, the DMA engine stops processing the channel. The current read-write sequence is allowed to finish. If the cancel occurs on the last read-write sequence of a major or minor loop, the cancel request is discarded and the channel retires normally.

The error cancel transfer is the same as a cancel transfer except the ES register is updated with the cancelled channel number and ECX is set. The TCD of a cancelled channel contains the source and destination addresses of the last transfer saved in the TCD. If the channel needs to be restarted, you must re-initialize the TCD because the aforementioned fields no longer represent the original parameters. When a transfer is cancelled by the error cancel transfer mechanism, the channel number is loaded into DMA_ES[ERRCHN] and ECX and VLD are set. In addition, an error interrupt may be generated if enabled.

The occurrence of any error causes the eDMA engine to stop the active channel immediately, and the appropriate channel bit in the eDMA error register is asserted. At the same time, the details of the error condition are loaded into the ES register. The major

loop complete indicators, setting the transfer control descriptor DONE flag and the possible assertion of an interrupt request, are not affected when an error is detected. After the error status has been updated, the eDMA engine continues operating by servicing the next appropriate channel. A channel that experiences an error condition is not automatically disabled. If a channel is terminated by an error and then issues another service request before the error is fixed, that channel executes and terminates with the same error condition.

21.4.3 Channel preemption

Channel preemption is enabled on a per-channel basis by setting the DCHPRIn[ECP] bit. Channel preemption allows the executing channel's data transfers to temporarily suspend in favor of starting a higher priority channel. After the preempting channel has completed all its minor loop data transfers, the preempted channel is restored and resumes execution. After the restored channel completes one read/write sequence, it is again eligible for preemption. If any higher priority channel is requesting service, the restored channel is suspended and the higher priority channel is serviced. Nested preemption, that is, attempting to preempt a preempting channel, is not supported. After a preempting channel begins execution, it cannot be preempted. Preemption is available only when fixed arbitration is selected.

A channel's ability to preempt another channel can be disabled by setting DCHPRIn[DPA]. When a channel's preempt ability is disabled, that channel cannot suspend a lower priority channel's data transfer, regardless of the lower priority channel's ECP setting. This allows for a pool of low priority, large data-moving channels to be defined. These low priority channels can be configured to not preempt each other, thus preventing a low priority channel from consuming the preempt slot normally available to a true, high priority channel.

21.4.4 Performance

This section addresses the performance of the eDMA module, focusing on two separate metrics:

- In the traditional data movement context, performance is best expressed as the peak data transfer rates achieved using the eDMA. In most implementations, this transfer rate is limited by the speed of the source and destination address spaces.
- In a second context where device-paced movement of single data values to/from peripherals is dominant, a measure of the requests that can be serviced in a fixed time is a more relevant metric. In this environment, the speed of the source and destination

address spaces remains important. However, the microarchitecture of the eDMA also factors significantly into the resulting metric.

21.4.4.1 Peak transfer rates

The peak transfer rates for several different source and destination transfers are shown in the following tables. These tables assume:

- Internal SRAM can be accessed with zero wait-states when viewed from the system bus data phase
- All internal peripheral bus reads require two wait-states, and internal peripheral bus writes three wait-states, when viewed from the system bus data phase
- All internal peripheral bus accesses are 32-bits in size

This table presents a peak transfer rate comparison.

Table 21-292. eDMA peak transfer rates (Mbytes/sec)

System Speed, Width	Internal SRAM-to- Internal SRAM	32b internal peripheral bus- to- Internal SRAM	Internal SRAM-to- 32b internal peripheral bus
66.7 MHz, 32b	133.3	66.7	53.3
83.3 MHz, 32b	166.7	83.3	66.7
100.0 MHz, 32b	200.0	100.0	80.0
133.3 MHz, 32b	266.7	133.3	106.7
150.0 MHz, 32b	300.0	150.0	120.0

Internal-SRAM-to-internal-SRAM transfers occur at the core's datapath width. For all transfers involving the internal peripheral bus, 32-bit transfer sizes are used. In all cases, the transfer rate includes the time to read the source plus the time to write the destination.

21.4.4.2 Peak request rates

The second performance metric is a measure of the number of DMA requests that can be serviced in a given amount of time. For this metric, assume that the peripheral request causes the channel to move a single internal peripheral bus-mapped operand to/from internal SRAM. The same timing assumptions used in the previous example apply to this calculation. In particular, this metric also reflects the time required to activate the channel.

The eDMA design supports the following hardware service request sequence:

Table 21-293. Hardware service request process, cycles 1–7

Cycle	Description
1	eDMA peripheral request is asserted.
2	The eDMA peripheral request is registered locally in the eDMA module and qualified. TCD _n _CSR[START] bit initiated requests start at this point with the registering of the user write to TCD _n word 7.
3	Channel arbitration begins.
4	Channel arbitration completes. The transfer control descriptor local memory read is initiated.
5–6	The first two parts of the activated channel's TCD is read from the local memory. The memory width to the eDMA engine is 64 bits, so the entire descriptor can be accessed in four cycles.
7	The first system bus read cycle is initiated, as the third part of the channel's TCD is read from the local memory. Depending on the state of the crossbar switch, arbitration at the system bus may insert an additional cycle of delay here.

The exact timing from this point is a function of the response times for the channel's read and write accesses. In the case of an internal peripheral bus read and internal SRAM write, the combined data phase time is 4 cycles. For an SRAM read and internal peripheral bus write, it is 5 cycles.

Table 21-294. Hardware service request process, cycles 8–17

Cycle, with internal peripheral bus read and internal SRAM write	Cycle, with SRAM read and internal peripheral bus write	Description
8–11	8–12	The last part of the TCD is read in. This cycle represents the first data phase for the read, and the address phase for the destination write.
12	13	This cycle represents the data phase of the last destination write.
13	14	The eDMA engine completes the execution of the inner minor loop and prepares to write back the required TCD _n fields into the local memory. The TCD _n word 7 is read and checked for channel linking or scatter/gather requests.
14	15	The appropriate fields in the first part of the TCD _n are written back into the local memory.
15	16	The fields in the second part of the TCD _n are written back into the local memory. This cycle coincides with the next channel arbitration cycle start.
16	17	The next channel to be activated performs the read of the first part of its TCD from the local memory. This is equivalent to Cycle 4 for the first channel's service request.

functional description

Assuming zero wait states on the system bus, DMA requests can be processed every 9 cycles. Assuming an average of the access times associated with internal peripheral bus-to-SRAM (4 cycles) and SRAM-to-internal peripheral bus (5 cycles), DMA requests can be processed every 11.5 cycles (4 + (4+5)/2 + 3). This is the time from Cycle 4 to Cycle ? +5. The resulting peak request rate, as a function of the system frequency, is shown in the following table.

Table 21-295. eDMA peak request rate (MReq/sec)

System frequency (MHz)	Request rate with zero wait states	Request rate with wait states
66.6	7.4	5.8
83.3	9.2	7.2
100.0	11.1	8.7
133.3	14.8	11.6
150.0	16.6	13.0

A general formula to compute the peak request rate with overlapping requests is:

$$PEAKreq = freq / [entry + (1 + read_ws) + (1 + write_ws) + exit]$$

where:

Table 21-296. Peak request formula legend

Where	Represents
PEAKreq	Peak request rate
freq	System frequency
entry	Channel startup (4 cycles)
read_ws	Wait states seen during the system bus read data phase
write_ws	Wait states seen during the system bus write data phase
xit	Channel shutdown (3 cycles)

For example, consider a system with the following characteristics:

- Internal SRAM can be accessed with one wait-state when viewed from the system bus data phase
- All internal peripheral bus reads require two wait-states, and internal peripheral bus writes three wait-states viewed from the system bus data phase
- System operates at 150 MHz

For an SRAM to internal peripheral bus transfer,

$$\text{PEAKreq} = 150 \text{ MHz} / [4 + (1 + 1) + (1 + 3) + 3] \text{ cycles} = 11.5 \text{ Mreq/sec}$$

For an internal peripheral bus to SRAM transfer,

$$\text{PEAKreq} = 150 \text{ MHz} / [4 + (1 + 2) + (1 + 1) + 3] \text{ cycles} = 12.5 \text{ Mreq/sec}$$

Assuming an even distribution of the two transfer types, the average peak request rate would be:

$$\text{PEAKreq} = (11.5 \text{ Mreq/sec} + 12.5 \text{ Mreq/sec}) / 2 = 12.0 \text{ Mreq/sec}$$

The minimum number of cycles to perform a single read/write, zero wait states on the system bus, from a cold start where no channel is executing and eDMA is idle are:

- 11 cycles for a software, that is, a $\text{TCDn_CSR}[\text{START}]$ bit, request
- 12 cycles for a hardware, that is, an eDMA peripheral request signal, request

Two cycles account for the arbitration pipeline and one extra cycle on the hardware request resulting from the internal registering of the eDMA peripheral request signals. For the peak request rate calculations above, the arbitration and request registering is absorbed in or overlaps the previous executing channel.

Note

When channel linking or scatter/gather is enabled, a two cycle delay is imposed on the next channel selection and startup. This allows the link channel or the scatter/gather channel to be eligible and considered in the arbitration pool for next channel selection.

21.5 Initialization/application information

The following sections discuss initialization of the eDMA and programming considerations.

21.5.1 eDMA initialization

A typical initialization of the eDMA has the following sequence:

1. Write the CR register if a configuration other than the default is desired.
2. Write the channel priority levels into the $\text{DCHPRI}n$ registers if a configuration other than the default is desired.

3. Enable error interrupts in the EEI register if so desired.
4. Write the 32-byte TCD for each channel that may request service.
5. Enable any hardware service requests via the ERQ register.
6. Request channel service via either:
 - Software: setting the TCD_n_CSR[START] bit
 - Hardware: slave device asserting its eDMA peripheral request signal

After any channel requests service, a channel is selected for execution based on the arbitration and priority levels written into the programmer's model. The eDMA engine reads the entire TCD, including the TCD control and status fields, as shown in the following table, for the selected channel into its internal address path module.

As the TCD is read, the first transfer is initiated on the internal bus unless a configuration error is detected. Transfers from the source, as defined by the source address, TCD_n_SADDR, to the destination, as defined by the destination address, TCD_n_DADDR, continue until the specified number of bytes (TCD_n_NBYTES) are transferred.

When the transfer is complete, the eDMA engine's local TCD_n_SADDR, TCD_n_DADDR, and TCD_n_CITER are written back to the main TCD memory and any minor loop channel linking is performed, if enabled. If the major loop is exhausted, further post processing executes, such as interrupts, major loop channel linking, and scatter/gather operations, if enabled.

Table 21-297. TCD Control and Status fields

TCD _n _CSR field name	Description
START	Control bit to start channel explicitly when using a software initiated DMA service (Automatically cleared by hardware)
ACTIVE	Status bit indicating the channel is currently in execution
DONE	Status bit indicating major loop completion (cleared by software when using a software initiated DMA service)
D_REQ	Control bit to disable DMA request at end of major loop completion when using a hardware initiated DMA service
BWC	Control bits for throttling bandwidth control of a channel
E_SG	Control bit to enable scatter-gather feature
INT_HALF	Control bit to enable interrupt when major loop is half complete
INT_MAJ	Control bit to enable interrupt when major loop completes

The following figure shows how each DMA request initiates one minor-loop transfer, or iteration, without CPU intervention. DMA arbitration can occur after each minor loop, and one level of minor loop DMA preemption is allowed. The number of minor loops in a major loop is specified by the beginning iteration count (BITER).

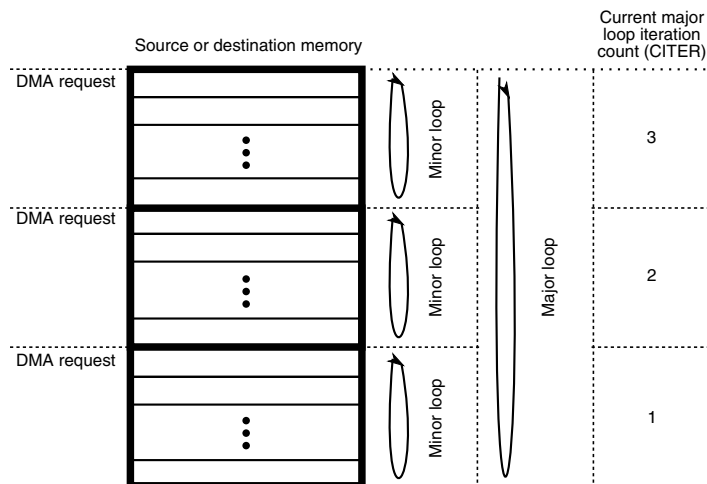

Figure 21-292. Example of multiple loop iterations

The following figure lists the memory array terms and how the TCD settings interrelate.

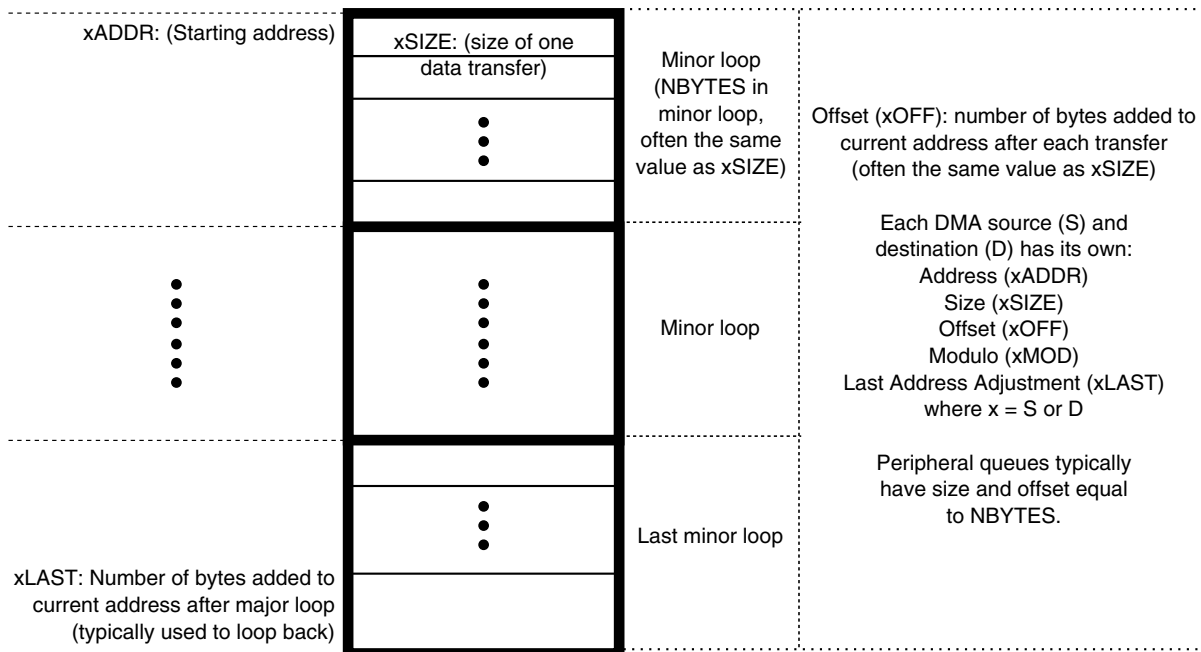

Figure 21-293. Memory array terms

21.5.2 Programming errors

The eDMA performs various tests on the transfer control descriptor to verify consistency in the descriptor data. Most programming errors are reported on a per channel basis with the exception of channel priority error (ES[CPE]).

For all error types other than channel priority error, the channel number causing the error is recorded in the ES register. If the error source is not removed before the next activation of the problem channel, the error is detected and recorded again.

If priority levels are not unique, when any channel requests service, a channel priority error is reported. The highest channel priority with an active request is selected, but the lowest numbered channel with that priority is selected by arbitration and executed by the eDMA engine. The hardware service request handshake signals, error interrupts, and error reporting is associated with the selected channel.

21.5.3 Arbitration mode considerations

21.5.3.1 Fixed channel arbitration

In this mode, the channel service request from the highest priority channel is selected to execute.

21.5.3.2 Round-robin channel arbitration

Channels are serviced starting with the highest channel number and rotating through to the lowest channel number without regard to the channel priority levels.

21.5.4 Performing DMA transfers

21.5.4.1 Single request

To perform a simple transfer of n bytes of data with one activation, set the major loop to one ($TCDn_CITER = TCDn_BITER = 1$). The data transfer begins after the channel service request is acknowledged and the channel is selected to execute. After the transfer is complete, the $TCDn_CSR[DONE]$ bit is set and an interrupt generates if properly enabled.

For example, the following TCD entry is configured to transfer 16 bytes of data. The eDMA is programmed for one iteration of the major loop transferring 16 bytes per iteration. The source memory has a byte wide memory port located at 0x1000. The destination memory has a 32-bit port located at 0x2000. The address offsets are programmed in increments to match the transfer size: one byte for the source and four bytes for the destination. The final source and destination addresses are adjusted to return to their beginning values.

```

TCDn_CITER = TCDn_BITER = 1
TCDn_NBYTES = 16
TCDn_SADDR = 0x1000
TCDn_SOFF = 1
TCDn_ATTR[SSIZE] = 0
TCDn_SLAST = -16
TCDn_DADDR = 0x2000
TCDn_DOFF = 4
TCDn_ATTR[DSIZE] = 2
TCDn_DLAST_SGA = -16
TCDn_CSR[INT_MAJ] = 1
TCDn_CSR[START] = 1 (Should be written last after all other fields have been initialized)
All other TCDn fields = 0
    
```

This generates the following event sequence:

1. User write to the TCDn_CSR[START] bit requests channel service.
2. The channel is selected by arbitration for servicing.
3. eDMA engine writes: TCDn_CSR[DONE] = 0, TCDn_CSR[START] = 0, TCDn_CSR[ACTIVE] = 1.
4. eDMA engine reads: channel TCD data from local memory to internal register file.
5. The source-to-destination transfers are executed as follows:
 - a. Read byte from location 0x1000, read byte from location 0x1001, read byte from 0x1002, read byte from 0x1003.
 - b. Write 32-bits to location 0x2000 → first iteration of the minor loop.
 - c. Read byte from location 0x1004, read byte from location 0x1005, read byte from 0x1006, read byte from 0x1007.
 - d. Write 32-bits to location 0x2004 → second iteration of the minor loop.
 - e. Read byte from location 0x1008, read byte from location 0x1009, read byte from 0x100A, read byte from 0x100B.
 - f. Write 32-bits to location 0x2008 → third iteration of the minor loop.
 - g. Read byte from location 0x100C, read byte from location 0x100D, read byte from 0x100E, read byte from 0x100F.

- h. Write 32-bits to location 0x200C → last iteration of the minor loop → major loop complete.
6. The eDMA engine writes: $TCDn_SADDR = 0x1000$, $TCDn_DADDR = 0x2000$, $TCDn_CITER = 1$ ($TCDn_BITER$).
7. The eDMA engine writes: $TCDn_CSR[ACTIVE] = 0$, $TCDn_CSR[DONE] = 1$, $INT[n] = 1$.
8. The channel retires and the eDMA goes idle or services the next channel.

21.5.4.2 Multiple requests

The following example transfers 32 bytes via two hardware requests, but is otherwise the same as the previous example. The only fields that change are the major loop iteration count and the final address offsets. The eDMA is programmed for two iterations of the major loop transferring 16 bytes per iteration. After the channel's hardware requests are enabled in the ERQ register, the slave device initiates channel service requests.

```
TCDn_CITER = TCDn_BITER = 2
TCDn_SLAST = -32
TCDn_DLAST_SGA = -32
```

This would generate the following sequence of events:

1. First hardware, that is, eDMA peripheral, request for channel service.
2. The channel is selected by arbitration for servicing.
3. eDMA engine writes: $TCDn_CSR[DONE] = 0$, $TCDn_CSR[START] = 0$, $TCDn_CSR[ACTIVE] = 1$.
4. eDMA engine reads: channel $TCDn$ data from local memory to internal register file.
5. The source to destination transfers are executed as follows:
 - a. Read byte from location 0x1000, read byte from location 0x1001, read byte from 0x1002, read byte from 0x1003.
 - b. Write 32-bits to location 0x2000 → first iteration of the minor loop.
 - c. Read byte from location 0x1004, read byte from location 0x1005, read byte from 0x1006, read byte from 0x1007.
 - d. Write 32-bits to location 0x2004 → second iteration of the minor loop.
 - e. Read byte from location 0x1008, read byte from location 0x1009, read byte from 0x100A, read byte from 0x100B.

- f. Write 32-bits to location 0x2008 → third iteration of the minor loop.
 - g. Read byte from location 0x100C, read byte from location 0x100D, read byte from 0x100E, read byte from 0x100F.
 - h. Write 32-bits to location 0x200C → last iteration of the minor loop.
6. eDMA engine writes: $TCDn_SADDR = 0x1010$, $TCDn_DADDR = 0x2010$, $TCDn_CITER = 1$.
 7. eDMA engine writes: $TCDn_CSR[ACTIVE] = 0$.
 8. The channel retires → one iteration of the major loop. The eDMA goes idle or services the next channel.
 9. Second hardware, that is, eDMA peripheral, requests channel service.
 10. The channel is selected by arbitration for servicing.
 11. eDMA engine writes: $TCDn_CSR[DONE] = 0$, $TCDn_CSR[START] = 0$, $TCDn_CSR[ACTIVE] = 1$.
 12. eDMA engine reads: channel TCD data from local memory to internal register file.
 13. The source to destination transfers are executed as follows:
 - a. Read byte from location 0x1010, read byte from location 0x1011, read byte from 0x1012, read byte from 0x1013.
 - b. Write 32-bits to location 0x2010 → first iteration of the minor loop.
 - c. Read byte from location 0x1014, read byte from location 0x1015, read byte from 0x1016, read byte from 0x1017.
 - d. Write 32-bits to location 0x2014 → second iteration of the minor loop.
 - e. Read byte from location 0x1018, read byte from location 0x1019, read byte from 0x101A, read byte from 0x101B.
 - f. Write 32-bits to location 0x2018 → third iteration of the minor loop.
 - g. Read byte from location 0x101C, read byte from location 0x101D, read byte from 0x101E, read byte from 0x101F.
 - h. Write 32-bits to location 0x201C → last iteration of the minor loop → major loop complete.
 14. eDMA engine writes: $TCDn_SADDR = 0x1000$, $TCDn_DADDR = 0x2000$, $TCDn_CITER = 2$ ($TCDn_BITER$).

15. eDMA engine writes: $TCDn_CSR[ACTIVE] = 0$, $TCDn_CSR[DONE] = 1$, $INT[n] = 1$.
16. The channel retires → major loop complete. The eDMA goes idle or services the next channel.

21.5.4.3 Using the modulo feature

The modulo feature of the eDMA provides the ability to implement a circular data queue in which the size of the queue is a power of 2. MOD is a 5-bit field for the source and destination in the TCD, and it specifies which lower address bits increment from their original value after the address+offset calculation. All upper address bits remain the same as in the original value. A setting of 0 for this field disables the modulo feature.

The following table shows how the transfer addresses are specified based on the setting of the MOD field. Here a circular buffer is created where the address wraps to the original value while the 28 upper address bits ($0x1234567x$) retain their original value. In this example the source address is set to $0x12345670$, the offset is set to 4 bytes and the MOD field is set to 4, allowing for a 2^4 byte (16-byte) size queue.

Table 21-298. Modulo example

Transfer Number	Address
1	0x12345670
2	0x12345674
3	0x12345678
4	0x1234567C
5	0x12345670
6	0x12345674

21.5.5 Monitoring transfer descriptor status

21.5.5.1 Testing for minor loop completion

There are two methods to test for minor loop completion when using software initiated service requests. The first is to read the $TCDn_CITER$ field and test for a change. Another method may be extracted from the sequence shown below. The second method is to test the $TCDn_CSR[START]$ bit and the $TCDn_CSR[ACTIVE]$ bit. The minor-loop-

complete condition is indicated by both bits reading zero after the `TCDn_CSR[START]` was set. Polling the `TCDn_CSR[ACTIVE]` bit may be inconclusive, because the active status may be missed if the channel execution is short in duration.

The TCD status bits execute the following sequence for a software activated channel:

Stage	TCDn_CSR bits			State
	START	ACTIVE	DONE	
1	1	0	0	Channel service request via software
2	0	1	0	Channel is executing
3a	0	0	0	Channel has completed the minor loop and is idle
3b	0	0	1	Channel has completed the major loop and is idle

The best method to test for minor-loop completion when using hardware, that is, peripheral, initiated service requests is to read the `TCDn_CITER` field and test for a change. The hardware request and acknowledge handshake signals are not visible in the programmer's model.

The TCD status bits execute the following sequence for a hardware-activated channel:

Stage	TCDn_CSR bits			State
	START	ACTIVE	DONE	
1	0	0	0	Channel service request via hardware (peripheral request asserted)
2	0	1	0	Channel is executing
3a	0	0	0	Channel has completed the minor loop and is idle
3b	0	0	1	Channel has completed the major loop and is idle

For both activation types, the major-loop-complete status is explicitly indicated via the `TCDn_CSR[DONE]` bit.

The `TCDn_CSR[START]` bit is cleared automatically when the channel begins execution regardless of how the channel activates.

21.5.5.2 Reading the transfer descriptors of active channels

The eDMA reads back the true `TCDn_SADDR`, `TCDn_DADDR`, and `TCDn_NBYTES` values if read while a channel executes. The true values of the `SADDR`, `DADDR`, and `NBYTES` are the values the eDMA engine currently uses in its internal register file and not the values in the TCD local memory for that channel. The addresses, `SADDR` and

DADDR, and NBYTES, decrements to zero as the transfer progresses, can give an indication of the progress of the transfer. All other values are read back from the TCD local memory.

21.5.5.3 Checking channel preemption status

Preemption is available only when fixed arbitration is selected as the channel arbitration mode. A preemptive situation is one in which a preempt-enabled channel runs and a higher priority request becomes active. When the eDMA engine is not operating in fixed channel arbitration mode, the determination of the actively running relative priority outstanding requests become undefined. Channel priorities are treated as equal, that is, constantly rotating, when Round-Robin Arbitration mode is selected.

The $TCDn_CSR[ACTIVE]$ bit for the preempted channel remains asserted throughout the preemption. The preempted channel is temporarily suspended while the preempting channel executes one major loop iteration. If two $TCDn_CSR[ACTIVE]$ bits are set simultaneously in the global TCD map, a higher priority channel is actively preempting a lower priority channel.

21.5.6 Dynamic programming

21.5.6.1 Dynamically changing the channel priority

The following two options are recommended for dynamically changing channel priority levels:

1. Switch to Round-Robin Channel Arbitration mode, change the channel priorities, then switch back to Fixed Arbitration mode,
2. Disable all the channels, change the channel priorities, then enable the appropriate channels.

21.5.6.2 Dynamically changing the channel linking and scatter/gather options

Dynamic channel linking and dynamic scatter/gather is the process of changing the $TCDn_CSR[MAJOR_E_LINK]$ or $TCDn_CSR[E_SG]$ bits during channel execution. These bits are read from the TCD local memory at the end of channel execution, therefore allowing software to enable either feature during channel execution.

Because software can change the configuration during execution, a coherency sequence must be followed. Consider the scenario the user attempts to execute a dynamic channel link by enabling the `TCDn_CSR[MAJOR_E_LINK]` bit as the eDMA engine retires the channel. The `TCDn_CSR[MAJOR_E_LINK]` would be set in the programmer's model, but it would be indeterminate whether the actual link was made before the channel retired.

The following coherency sequence is recommended when executing a dynamic channel link or dynamic scatter/gather request:

1. Set the `TCDn_CSR[MAJOR_E_LINK]` bit.
2. Read back the `TCDn_CSR[MAJOR_E_LINK]` bit.
3. Test the `TCDn_CSR[MAJOR_E_LINK]` request status.
 - a. If the bit is set, the dynamic link attempt was successful.
 - b. If the bit is cleared, the attempted dynamic link did not succeed, the channel was already retiring.

This coherency model is true for dynamic scatter/gather operations. For both dynamic requests, the TCD local memory controller forces the `TCDn_CSR[MAJOR_E_LINK]` and `TCDn_CSR[E_SG]` bits to zero on any writes to a `TCDn` after the `TCDn_CSR[DONE]` bit for that channel is set, indicating that the major loop is complete.

Note

Software must clear the `TCDn_CSR[DONE]` bit before writing the `TCDn_CSR[MAJOR_E_LINK]` or `TCDn_CSR[E_SG]` bits. The `TCDn_CSR[DONE]` bit is cleared automatically by the eDMA engine after a channel begins execution.

Chapter 22

External Watchdog Monitor (EWM)

22.1 Introduction

NOTE

For the chip-specific implementation details of this module's instances see the chip configuration chapter.

The watchdog is generally used to monitor the flow and execution of embedded software within an MCU. The watchdog consists of a counter that if allowed to overflow, forces an internal reset (asynchronous) to all on-chip peripherals and optionally assert the $\overline{\text{RESET}}$ pin to reset external devices/circuits. The overflow of the watchdog counter must not occur if the software code works well and services the watchdog to re-start the actual counter.

For safety, a redundant watchdog system, External Watchdog Monitor (EWM), is designed to monitor external circuits, as well as the MCU software flow. This provides a back-up mechanism to the internal watchdog that resets the MCU's CPU and peripherals.

The EWM differs from the internal watchdog in that it does not reset the MCU's CPU and peripherals. The EWM if allowed to time-out, provides an independent $\overline{\text{EWM_out}}$ pin that when asserted resets or places an external circuit into a safe mode. The CPU resets the EWM counter that is logically ANDed with an external digital input pin. This pin allows an external circuit to influence the reset_out signal.

22.1.1 Features

Features of EWM module include:

- Independent LPO clock source
- Programmable time-out period specified in terms of number of EWM LPO clock cycles.

- Windowed refresh option
 - Provides robust check that program flow is faster than expected.
 - Programmable window.
 - Refresh outside window leads to assertion of $\overline{\text{EWM_out}}$.
- Robust refresh mechanism
 - Write values of 0xB4 and 0x2C to EWM Refresh Register within 15 (*EWM_service_time*) peripheral bus clock cycles.
- One output port, $\overline{\text{EWM_out}}$, when asserted is used to reset or place the external circuit into safe mode.
- One Input port, *EWM_in*, allows an external circuit to control the $\overline{\text{EWM_out}}$ signal.

22.1.2 Modes of Operation

This section describes the module's operating modes.

22.1.2.1 Stop Mode

When the EWM is in stop mode, the CPU services to the EWM cannot occur. On entry to stop mode, the EWM's counter freezes.

There are two possible ways to exit from Stop mode:

- On exit from stop mode through a reset, the EWM remains disabled.
- On exit from stop mode by an interrupt, the EWM is re-enabled, and the counter continues to be clocked from the same value prior to entry to stop mode.

Note the following if the EWM enters the stop mode during CPU service mechanism: At the exit from stop mode by an interrupt, refresh mechanism state machine starts from the previous state which means, if first service command is written correctly and EWM enters the stop mode immediately, the next command has to be written within the next 15 (*EWM_service_time*) peripheral bus clocks after exiting from stop mode. User must mask all interrupts prior to executing EWM service instructions.

22.1.2.2 Wait Mode

The EWM module treats the stop and wait modes as the same. EWM functionality remains the same in both of these modes.

22.1.2.3 Debug Mode

Entry to debug mode has no effect on the EWM.

- If the EWM is enabled prior to entry of debug mode, it remains enabled.
- If the EWM is disabled prior to entry of debug mode, it remains disabled.

22.1.3 Block Diagram

This figure shows the EWM block diagram.

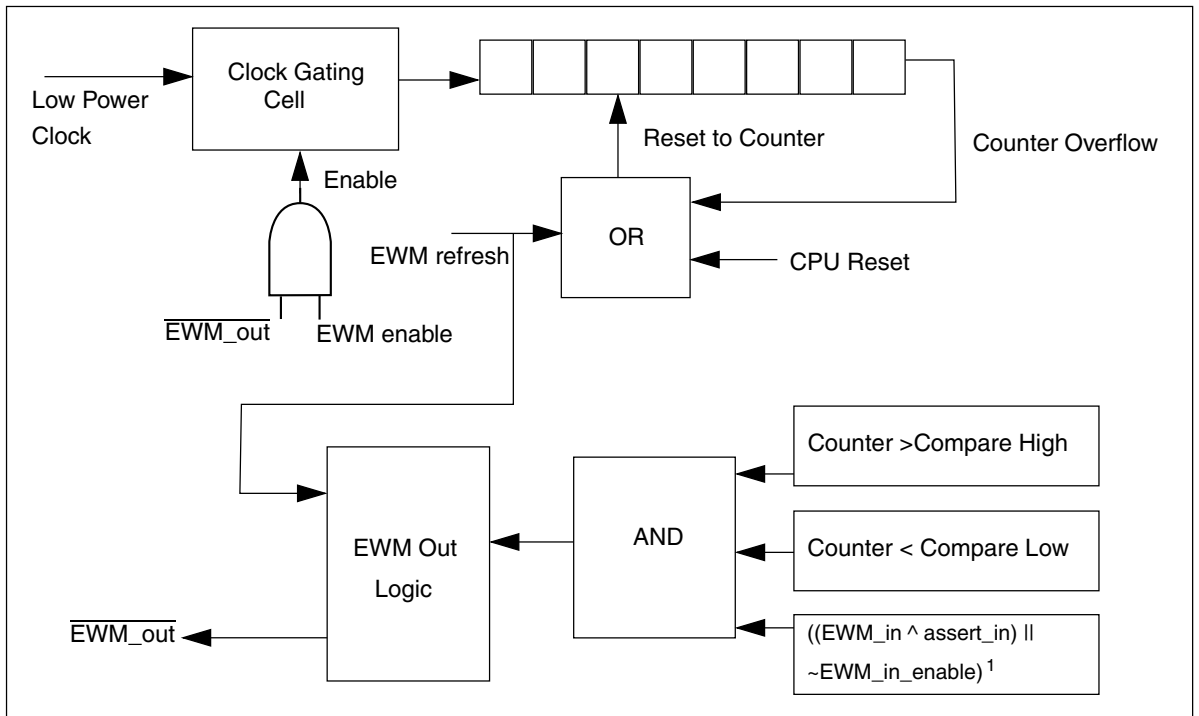

¹ Compare High > Counter > Compare Low

Figure 22-1. EWM Block Diagram

22.2 EWM Signal Descriptions

The EWM has two external signals, as shown in the following table.

Table 22-1. EWM Signal Descriptions

Signal	Description	I/O
EWM_in	EWM input for safety status of external safety circuits. The polarity of EWM_in is programmable using the CTRL[ASSIN] bit. The default polarity is active-low.	I
EWM_out	EWM reset out signal	O

22.3 Memory Map/Register Definition

This section contains the module memory map and registers.

EWM memory map

Absolute address (hex)	Register name	Width (in bits)	Access	Reset value	Section/page
4006_1000	Control Register (EWM_CTRL)	8	R/W	00h	22.3.1/490
4006_1001	Service Register (EWM_SERV)	8	W (always reads zero)	00h	22.3.2/491
4006_1002	Compare Low Register (EWM_CMPL)	8	R/W	00h	22.3.3/492
4006_1003	Compare High Register (EWM_CMPH)	8	R/W	FFh	22.3.4/492

22.3.1 Control Register (EWM_CTRL)

The CTRL register is cleared by any reset.

NOTE

This register can be written only once after a CPU reset. Writing this register more than once, generates a bus transfer error.

Address: EWM_CTRL is 4006_1000h base + 0h offset = 4006_1000h

Bit	7	6	5	4	3	2	1	0
Read	0							
Write						INEN	ASSIN	EWMEN
Reset	0	0	0	0	0	0	0	0

EWM_CTRL field descriptions

Field	Description
7-3 Reserved	This read-only field is reserved and always has the value zero.
2 INEN	Input Enable. This bit when set, enables the EWM_in port.
1 ASSIN	EWM_in's Assertion State Select. Default assert state of the EWM_in signal is logic zero. Setting ASSIN bit inverts the assert state to a logic one.
0 EWMEN	EWM enable. This bit when set, enables the EWM module. This resets the EWM counter to zero and deasserts the EWM_out signal. Clearing EWMEN bit disables the EWM, and therefore it cannot be enabled until a reset occurs, due to the write-once nature of this bit.

22.3.2 Service Register (EWM_SERV)

The SERV register provides the interface from the CPU to the EWM module. It is write-only and reads of this register return zero.

Address: EWM_SERV is 4006_1000h base + 1h offset = 4006_1001h

Bit	7	6	5	4	3	2	1	0
Read	0							
Write	SERVICE							
Reset	0	0	0	0	0	0	0	0

EWM_SERV field descriptions

Field	Description
7-0 SERVICE	The EWM service mechanism requires the CPU to write two values to the SERV register: a first data byte of 0xB4, followed by a second data byte of 0x2C. The EWM service is illegal if either of the following conditions is true. <ul style="list-style-type: none"> The first or second data byte is not written correctly. The second data byte is not written within a fixed number of peripheral bus cycles of the first data byte. This fixed number of cycles is called <i>EWM_service_time</i>.

22.3.3 Compare Low Register (EWM_CMPL)

The CMPL register is reset to zero after a CPU reset. This provides no minimum time for the CPU to service the EWM counter.

NOTE

This register can be written only once after a CPU reset. Writing this register more than once generates a bus transfer error.

Address: EWM_CMPL is 4006_1000h base + 2h offset = 4006_1002h

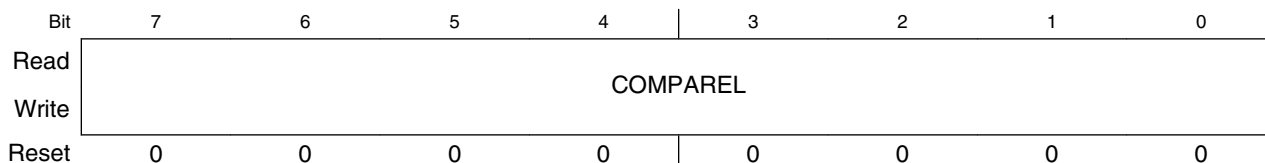

EWM_CMPL field descriptions

Field	Description
7-0 COMPAREL	To prevent runaway code from changing this field, software should write to this field after a CPU reset even if the (default) minimum service time is required.

22.3.4 Compare High Register (EWM_CMPH)

The CMPH register is reset to 0xFF after a CPU reset. This provides a maximum of 256 clocks time, for the CPU to service the EWM counter.

NOTE

This register can be written only once after a CPU reset. Writing this register more than once generates a bus transfer error.

NOTE

The valid values for CMPH are up to 0xFE because the EWM counter never expires when CMPH = 0xFF. The expiration happens only if EWM counter is greater than CMPH.

Address: EWM_CMPH is 4006_1000h base + 3h offset = 4006_1003h

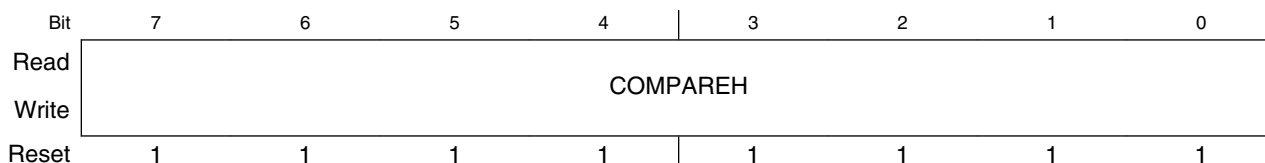

EWM_CMPH field descriptions

Field	Description
7-0 COMPAREH	To prevent runaway code from changing this field, software should write to this field after a CPU reset even if the (default) maximum service time is required.

22.4 Functional Description

The following sections describe functional details of the EWM module.

22.4.1 The $\overline{\text{EWM_out}}$ Signal

The $\overline{\text{EWM_out}}$ is a digital output signal used to gate an external circuit (application specific) that controls critical safety functions. For example, the $\overline{\text{EWM_out}}$ could be connected to the high voltage transistors circuits that control an AC motor in a large appliance.

The $\overline{\text{EWM_out}}$ signal remains deasserted when the EWM is being regularly serviced by the CPU within the programmable service window, indicating that the application code is executed as expected.

The $\overline{\text{EWM_out}}$ signal is asserted in any of the following conditions:

- Servicing the EWM when the counter value is less than CMPL value.
- If the EWM counter value reaches the CMPH value, and no EWM service has occurred.
- Servicing the EWM when the counter value is more than CMPL and less than CMPH values and EWM_in signal is asserted.
- After any reset (by the virtue of the external pull-down mechanism on the $\overline{\text{EWM_out}}$ pin)

On a normal reset, the $\overline{\text{EWM_out}}$ is asserted. To deassert the $\overline{\text{EWM_out}}$, set EWMEN bit in the CTRL register to enable the EWM.

If the $\overline{\text{EWM_out}}$ signal shares its pad with a digital I/O pin, on reset this actual pad defers to being an input signal. It takes the $\overline{\text{EWM_out}}$ output condition only after you enable the EWM by the EWMEN bit in the CTRL register.

When the $\overline{\text{EWM_out}}$ pin is asserted, it can only be deasserted by forcing a MCU reset.

Note

$\overline{\text{EWM_out}}$ pad must be in pull down state when EWM functionality is used and when EWM is under Reset.

22.4.2 The EWM_in Signal

The EWM_in is a digital input signal that allows an external circuit to control the EWM_out signal. For example, in the application, an external circuit monitors a critical safety function, and if there is fault with this circuit's behavior, it can then actively initiate the $\overline{\text{EWM_out}}$ signal that controls the gating circuit.

The EWM_in signal is ignored if the EWM is disabled, or if INEN bit of CTRL register is cleared, as after any reset.

On enabling the EWM (setting the CTRL[EWMEN] bit) and enabling EWM_in functionality (setting the CTRL[INEN] bit), the EWM_in signal must be in the deasserted state prior to the CPU servicing the EWM. This ensures that the $\overline{\text{EWM_out}}$ stays in the deasserted state; otherwise, the $\overline{\text{EWM_out}}$ pin is asserted.

Note

You must update the CMPH and CMPL registers prior to enabling the EWM. After enabling the EWM, the counter resets to zero, therefore providing a reasonable time after a power-on reset for the external monitoring circuit to stabilize and ensure that the EWM_in pin is deasserted.

22.4.3 EWM Counter

It is an 8-bit ripple counter fed from a clock source that is independent of the peripheral bus clock source. As the preferred time-out is between 1 ms and 100 ms the actual clock source should be in the kHz range.

The counter is reset to zero, after a CPU reset, or a EWM refresh cycle. The counter value is not accessible to the CPU.

22.4.4 EWM Compare Registers

The compare registers CMPL and CMPH are write-once after a CPU reset and cannot be modified until another CPU reset occurs.

The EWM compare registers are used to create a service window, which is used by the CPU to service/refresh the EWM module.

- If the CPU services the EWM when the counter value lies between CMPL value and CMPH value, the counter is reset to zero. This is a legal service operation.
- If the CPU executes a EWM service/refresh action outside the legal service window, $\overline{\text{EWM_out}}$ is asserted.

It is illegal to program CMPL and CMPH with same value. In this case, as soon as counter reaches (CMPL + 1), $\overline{\text{EWM_out}}$ is asserted.

22.4.5 EWM Refresh Mechanism

Other than the initial configuration of the EWM, the CPU can only access the EWM by the EWM Service Register. The CPU must access the EWM service register with correct write of unique data within the windowed time frame as determined by the CMPL and CMPH registers. Therefore, three possible conditions can occur:

Table 22-7. EWM Refresh Mechanisms

Condition	Mechanism
A unique EWM service occurs when $\text{CMPL} < \text{Counter} < \text{CMPH}$.	The software behaves as expected and the counter of the EWM is reset to zero, and $\overline{\text{EWM_out}}$ pin remains in the deasserted state. Note: $\overline{\text{EWM_in}}$ pin is also assumed to be in the deasserted state.
A unique EWM service occurs when $\text{Counter} < \text{CMPL}$	The software services the EWM and therefore resets the counter to zero and asserts the $\overline{\text{EWM_out}}$ pin (irrespective of the $\overline{\text{EWM_in}}$ pin). The $\overline{\text{EWM_out}}$ pin is expected to gate critical safety circuits.
Counter value reaches CMPH prior to a unique EWM service	The counter value reaches the CMPH value and no service of the EWM resets the counter to zero and assert the $\overline{\text{EWM_out}}$ pin (irrespective of the $\overline{\text{EWM_in}}$ pin). The $\overline{\text{EWM_out}}$ pin is expected to gate critical safety circuits.

Any illegal service on EWM has no effect on $\overline{\text{EWM_out}}$.

Chapter 23

Watchdog Timer (WDOG)

23.1 Introduction

NOTE

For the chip-specific implementation details of this module's instances see the chip configuration chapter.

The Watchdog Timer (WDOG) keeps a watch on the system functioning and resets it in case of its failure. Some reasons for such failures are: run-away software code and the stoppage of the system clock that in a safety critical system can lead to serious consequences. In such cases, the watchdog brings the system into a safe state of operation. The watchdog monitors the operation of the system by expecting periodic communication from the software, generally known as servicing or refreshing the watchdog. If this periodic refreshing does not occur, the watchdog resets the system.

23.2 Features

The features of the Watchdog Timer (WDOG) include:

- Independent clock source input (independent from CPU/bus clock). Choice between two clock sources:
 - LPO Oscillator
 - External system clock
- Unlock sequence for allowing updates to write-once WDOG control/configuration bits.
- All WDOG control/configuration bits are writable once only within 256 bus clock cycles of being unlocked.

- You need to always update these bits after unlocking within 256 bus clock cycles. Failure to update these bits, resets the system.
- Programmable time-out period specified in terms of number of WDOG clock cycles.
- Ability to test WDOG timer and reset with a flag indicating watchdog test.
 - Quick test—Small time-out value programmed for quick test.
 - Byte test—Individual bytes of timer tested one at a time.
 - Read-only access to the WDOG timer—Allows dynamic check that WDOG timer is operational.

NOTE

Reading the watchdog timer counter while running the watchdog on the bus clock might not give the accurate counter value.

- Windowed refresh option
 - Provides robust check that program flow is faster than expected.
 - Programmable window.
 - Refresh outside window leads to reset.
- Robust refresh mechanism
 - Write values of 0xA602 and 0xB480 to WDOG Refresh Register within 20 bus clock cycles.
- Count of WDOG resets as they occur.
- Configurable interrupt on time-out to provide debug breadcrumbs. This is followed by a reset after 256 bus clock cycles.

23.3 Functional Overview

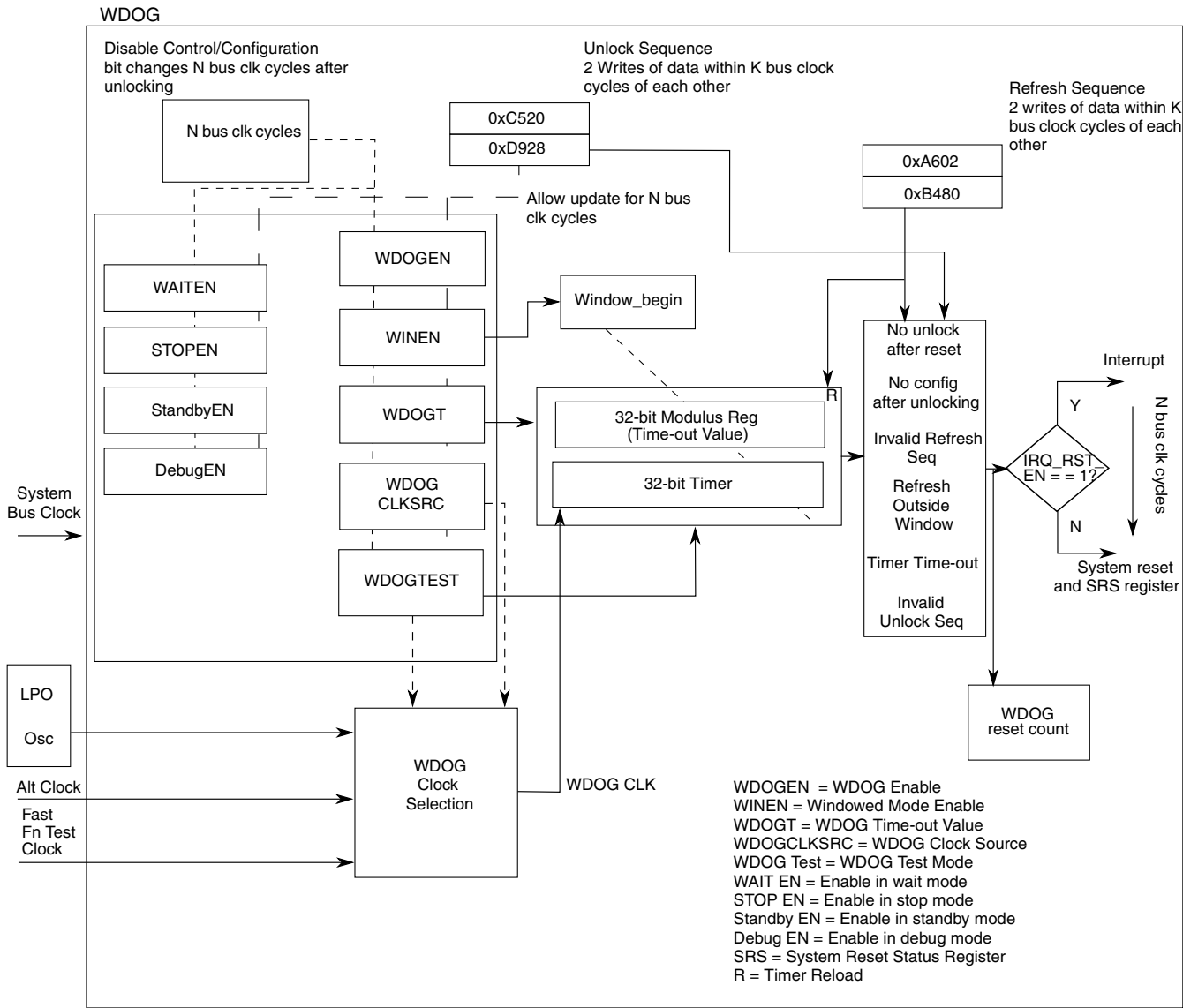

Figure 23-1. WDOG Operation

The preceding figure shows the operation of the watchdog. The values for N and K are:

- N = 256
- K = 20

The watchdog is a fail safe mechanism that brings the system into a known initial state in case of its failure due to CPU clock stopping or a run away condition in code execution. In its simplest form, the watchdog timer runs continuously off a clock source and expects

to be serviced periodically, failing which it resets the system. This ensures that the software is executing correctly and has not run away in an unintended direction. Software can adjust the period of servicing or the time-out value for the watchdog timer to meet the needs of the application.

You can select a windowed mode of operation that expects the servicing to be done only in a particular window of the time-out period. An attempted servicing of the watchdog outside this window results in a reset. By operating in this mode, you can get an indication of whether the code is running faster than expected. The window length is also user programmable.

If a system fails to update/refresh the watchdog due to an unknown and persistent cause, it will be caught in an endless cycle of resets from the watchdog. To analyze the cause of such conditions, you can program the watchdog to first issue an interrupt, followed a little later by a reset. In the interrupt service routine, the software can analyze the system stack to aid debugging.

To enhance the independence of watchdog from the system, it runs off an independent LPO oscillator clock. You can also switch over to an alternate clock source if required, through a control register bit.

23.3.1 Unlocking and Updating the Watchdog

You can unlock the write-once-only control and configuration registers for updating them. As a pre-condition, the `ALLOW_UPDATE` bit in the watchdog control register must be set. The actual unlock is accomplished by writing `0xC520` followed by `0xD928` within 20 bus clock cycles to a specific unlock register (`WDOG_UNLOCK`). This opens up an update window equal in length to the watchdog configuration time (`WCT`) within which you can update the configuration and control register bits. You can not update registers on the bus clock cycle immediately following the write of the unlock sequence, but one cycle later. These register bits can be modified only once after unlocking.

If none of the configuration and control registers is updated within the update window, the watchdog issues a reset (or interrupt-then-reset) to the system. Trying to unlock the watchdog within the `WCT` time after an initial unlock, has no effect. During the update operation, the watchdog timer is not paused and keeps running in the background. After the update window closes, the watchdog timer restarts and the watchdog functions as per the new configuration.

The update feature is useful for applications that have an initial, non-safety critical part, where the watchdog is kept disabled or with a conveniently long time-out period. This means the application coder does not have to bother with frequently servicing the watchdog. After the critical part of the application begins, the watchdog can be reconfigured as per need.

The watchdog issues a reset (or interrupt-then-reset if enabled) to the system for any of these invalid unlock sequences:

- You write any value other than 0xC520 or 0xD928 to the unlock register.
- ALLOW_UPDATE is set and you allow a gap of more than 20 bus clock cycles between the writing of the unlock sequence values.

Also, an attempted refresh operation between the two writes of the unlock sequence and in the WCT time following a successful unlock, goes undetected. Also, see [Watchdog Operation with 8-bit access](#) for guidelines related to 8-bit accesses to the unlock register.

Note

A context switch during unlocking and refreshing may lead to a watchdog reset.

23.3.2 The Watchdog Configuration Time (WCT)

To prevent unintended modification of the watchdog's control and configuration register bits, you are allowed to update them only within a period of 256 bus clock cycles after unlocking. This window period is known as the watchdog configuration time (WCT). In addition, these register bits can be modified only once after unlocking them for editing (even after reset).

You must unlock the registers within WCT time after system reset, failing which the WDOG issues a reset to the system. To be more precise, you must write at least the first word of the unlocking sequence within the WCT time after reset. Once this is done, you get a further 20 bus clock cycles (the maximum allowed gap between the words of the unlock sequence) to complete the unlocking operation. Thereafter, to make sure that you do not forget to configure the watchdog, the watchdog issues a reset if none of the WDOG control and configuration registers is updated in the WCT time after unlock. After the close of this window or after the first write, these register bits are locked out from any further changes.

The watchdog timer keeps running as per its default configuration through unlocking and update operations that can extend up to a maximum total of $2 \times \text{WCT time} + 20$ bus clock cycles. Therefore, it must be ensured that the time-out value for the watchdog is always greater than $2 \times \text{WCT time} + 20$ bus clock cycles.

Updates in the write–once registers take effect only after the WCT window closes with the following exceptions for which changes take effect immediately:

- the stop, wait, and debug mode enable bits
- the standby mode enable bit
- the IRQ_RST_EN bit

The operations of refreshing the watchdog goes undetected during the WCT.

23.3.3 Refreshing the Watchdog

A robust refreshing mechanism has been chosen for the watchdog. A valid refresh is a write of 0xA602 followed by 0xB480 within 20 bus clock cycles to watchdog refresh register. If these two values are written more than 20 bus cycles apart or if something other than these two values is written to the register, a watchdog reset (or interrupt-then-reset if enabled) is issued to the system. A valid refresh makes the watchdog timer restart on the next bus clock. Also, an attempted unlock operation, in between the two writes of the refresh sequence goes undetected. See [Watchdog Operation with 8-bit access](#) for guidelines related to 8-bit accesses to the refresh register.

23.3.4 Windowed Mode of Operation

In this mode of operation a restriction is placed on the point in time within the time-out period at which the watchdog can be refreshed. The refresh is considered valid only when the watchdog timer increments beyond a certain count as specified by the watchdog window register. This is known as refreshing the watchdog within a window of the total time-out period. If a refresh is attempted before the timer reaches the window value, the watchdog generates a reset (or interrupt-then-reset if enabled). Of course, if there is no refresh at all, the watchdog times out and generates a reset or interrupt-then-reset if enabled.

23.3.5 Watchdog Disabled Mode of Operation

When the watchdog is disabled through the WDOG_EN bit in the watchdog status and control register, the watchdog timer is reset to zero and is disabled from counting until you enable it or it is again enabled by the system reset. In this mode the watchdog timer cannot be refreshed (there is no requirement to do so while the timer is disabled). However, the watchdog still generates a reset (or interrupt-then-reset if enabled) on a

non-time-out exception (see [Generated Resets and Interrupts](#)). You need to unlock the watchdog before enabling it. A system reset brings the watchdog out of the disabled mode.

23.3.6 Low Power Modes of Operation

- In Wait mode, if the WDOG is enabled ($WAIT_EN = 1$), it can run on bus clock or low power oscillator clock ($CLK_SRC = x$) to generate interrupt ($IRQ_RST_EN=1$) followed by a reset on time-out. After reset the WDOG reset counter increments by one.
- In Stop mode where the bus clock is gated, the WDOG can run only on low power oscillator clock ($CLK_SRC=0$) if it is enabled in stop ($STOP_EN=1$). In this case, the WDOG runs to time-out twice, and then generates a reset from its backup circuitry. Therefore, if you program the watchdog to time-out after 100 ms and then enter such a stop mode, the reset will occur after 200 ms. Also, in this case no interrupt will be generated irrespective of the value of IRQ_RST_EN bit. After WDOG reset, the WDOG reset counter will also not increment.
- In Power-down mode, the watchdog is powered off.

23.3.7 Debug Modes of Operation

You can program the watchdog to disable in debug modes (through DBG_EN bit in the watchdog control register). This results in the watchdog timer pausing for the duration of the mode. Register read/writes are still allowed, which means that operations like: refresh, unlock etc. are allowed. On exit from the mode, the timer resumes its operation from the point of pausing.

The entry of the system into the debug mode does not excuse it from compulsorily configuring the watchdog in the WCT time after unlock (unless the system bus clock is gated off, in which case the internal state machine pauses too). Failing to do so still results in a reset (or interrupt-then-reset, if enabled) to the system. Also, all the exception conditions that result in a reset to the system (see [Generated Resets and Interrupts](#)) are still valid in this mode. So, if an exception condition occurs and the system bus clock is on, a reset occurs (or interrupt-then-reset, if enabled).

The entry into Debug mode within WCT time after reset is treated differently. The WDOG timer is kept reset to zero and there is no need to unlock and configure it within WCT time. You must not try to refresh or unlock the WDOG in this state or unknown behavior may result. Upon exit from this mode, the WDOG timer restarts and the WDOG has to be unlocked and configured within WCT time.

23.4 Testing the Watchdog

For IEC 60730 and other safety standards, the expectation is that anything that monitors a safety function must be tested and this test is required to be fault tolerant. To test the watchdog, its main timer and its associated compare and reset logic must be tested. Towards this end, two tests are implemented for the watchdog that are described in [Quick Test](#) and [Byte Test](#). While there is a control bit provided to put the watchdog into the test mode (functional), there is an overriding test-disable control bit which once set, disables the test mode permanently until reset.

For running a particular test, first select that test. Thereafter, set a certain test mode bit to put the watchdog in the functional test mode. Setting this bit automatically switches the watchdog timer to a fast clock source. The switching of the clock source is done to achieve a faster time-out and hence a faster test. In a successful test, the timer times out after reaching the programmed time-out value and generates a system reset.

Note

After emerging from a reset due to a watchdog test, you must follow the mandatory steps of unlocking and configuring the watchdog. The refresh and unlock operations and interrupt are not automatically disabled in the test mode.

23.4.1 Quick Test

In this test the time-out value of watchdog timer is programmed to a very low value to achieve quick time-out. The only difference between the quick test and the normal mode of functioning of the watchdog is that the test mode bit is set for the quick test. This allows quick test of the watchdog reset mechanism.

23.4.2 Byte Test

The byte test implements more thorough a test of the watchdog timer. In this test, the timer is split up into its constituent byte-wide stages that are run independently and tested for time-out against the corresponding byte of the time-out value register. The following figure explains the splitting concept:

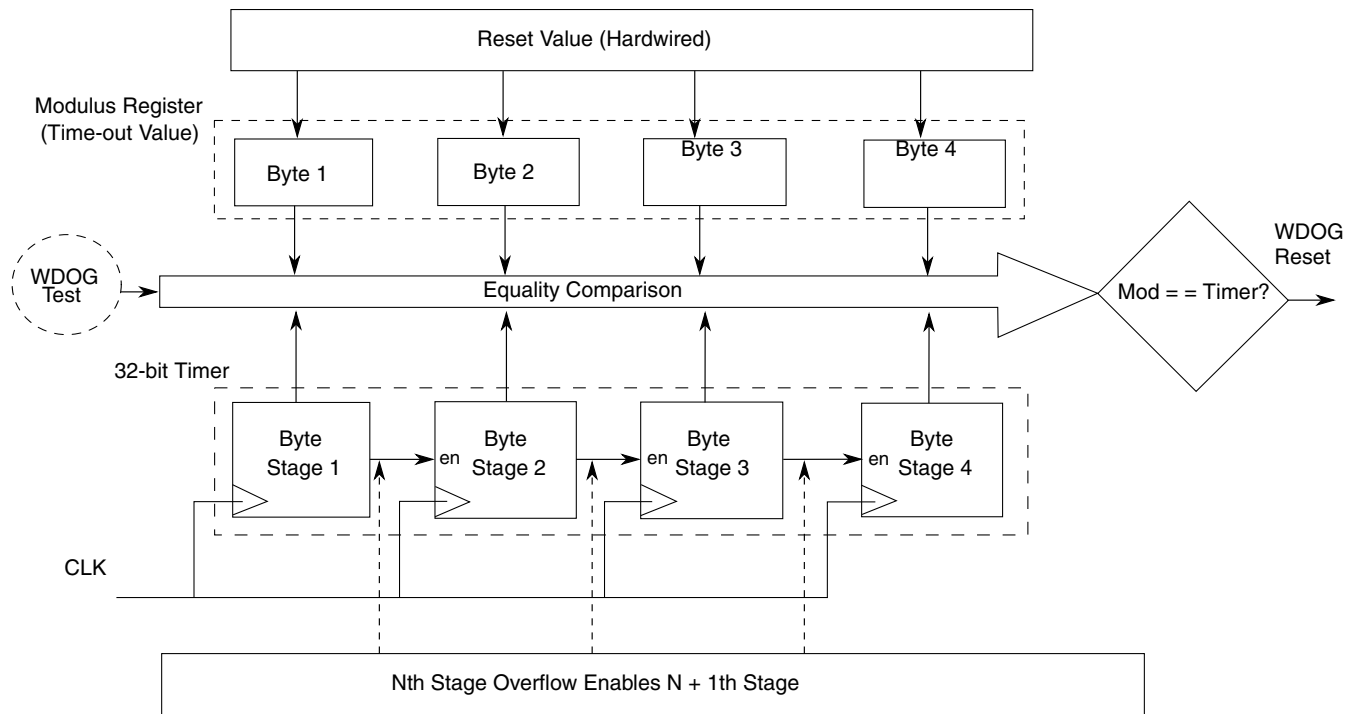

Figure 23-2. Watchdog Timer Byte Splitting

Each stage is an 8-bit synchronous counter followed by combinational logic that generates an overflow signal. The overflow signal acts as an enable to the $N + 1$ th stage.

In the test mode, when an individual byte, N , is tested, byte $N - 1$ is loaded forcefully with $0xFF$, and both these bytes are allowed to run off the clock source. By doing so the overflow signal from stage $N - 1$ is generated immediately, enabling counter stage N . The N th stage runs and compares with the N th byte of the time-out value register. In this way, the byte N is also tested along with the link between it and the preceding stage. No other stages, $N - 2$, $N - 3...$ and $N + 1$, $N + 2...$ are enabled for the test on byte N . These disabled stages (except the most significant stage of the counter) are loaded with a value of $0xFF$.

These two testing schemes achieve the overall aim of testing the counter functioning and the compare and reset logic.

Note

Do not enable the watchdog interrupt during these tests. If required, you must ensure that the effective time-out value is greater than WCT time. See [Generated Resets and Interrupts](#) for more details.

23.5 Backup Reset Generator

The backup reset generator generates the final reset which goes out to the system. It has a backup mechanism which takes care that in case the bus clock stops and prevents the main state machine from generating a reset exception/interrupt, the watchdog timer's time-out is separately routed out as a reset to the system. Two successive timer time-outs without an intervening system reset result in the backup reset generator routing out the time-out signal as a reset to the system.

23.6 Generated Resets and Interrupts

The watchdog generates a reset on the following events (referred to as exceptions at some places in this document):

- A watchdog time-out.
- Failure to unlock the watchdog within WCT time after system reset deassertion.
- No update of the control and configuration registers within the WCT window after unlocking. At least one of the following registers must be written to within the WCT window to avoid reset:
 - WDOG_ST_CTRL_H, WDOG_ST_CTRL_L
 - WDOG_TO_VAL_H, WDOG_TO_VAL_L
 - WDOG_WIN_H, WDOG_WIN_L
 - WDOG_PRESCALER
- A value other than the unlock sequence or the refresh sequence is written to the unlock and/or refresh registers, respectively.

- A gap of more than 20 bus cycles exists between the writes of two values of the unlock sequence.
- A gap of more than 20 bus cycles exists between the writes of two values of the refresh sequence.

The watchdog can also generate an interrupt. If `IRQ_RST_EN` is set, then on the above mentioned events `WDOG_ST_CTRL_L[INT_FLG]` is set, generating an interrupt. A watchdog reset is also generated WCT time later to ensure the watchdog is fault tolerant. The interrupt can be cleared by writing 1 to `INT_FLG`.

The gap of WCT time between interrupt and reset means that the WDOG time-out value must be greater than WCT. Otherwise, if the interrupt was generated due to a time-out, a second consecutive time-out will occur in that WCT gap. This will trigger the backup reset generator to generate a reset to the system, prematurely ending the interrupt service routine execution. Also, the jobs like counting the number of watchdog resets would not be done.

23.7 Memory Map and Register Definition

This section consists of the memory map and register descriptions.

WDOG memory map

Absolute address (hex)	Register name	Width (in bits)	Access	Reset value	Section/page
4005_2000	Watchdog Status and Control Register High (WDOG_STCTRLH)	16	R/W	01D3h	23.7.1/508
4005_2002	Watchdog Status and Control Register Low (WDOG_STCTRL)	16	R/W	0001h	23.7.2/510
4005_2004	Watchdog Time-out Value Register High (WDOG_TOVALH)	16	R/W	004Ch	23.7.3/510
4005_2006	Watchdog Time-out Value Register Low (WDOG_TOVALL)	16	R/W	4B4Ch	23.7.4/511
4005_2008	Watchdog Window Register High (WDOG_WINH)	16	R/W	0000h	23.7.5/511
4005_200A	Watchdog Window Register Low (WDOG_WINL)	16	R/W	0010h	23.7.6/512
4005_200C	Watchdog Refresh Register (WDOG_REFRESH)	16	R/W	B480h	23.7.7/512

Table continues on the next page...

WDOG memory map (continued)

Absolute address (hex)	Register name	Width (in bits)	Access	Reset value	Section/page
4005_200E	Watchdog Unlock Register (WDOG_UNLOCK)	16	R/W	D928h	23.7.8/512
4005_2010	Watchdog Timer Output Register High (WDOG_TMROUTH)	16	R/W	0000h	23.7.9/513
4005_2012	Watchdog Timer Output Register Low (WDOG_TMROUTL)	16	R/W	0000h	23.7.10/513
4005_2014	Watchdog Reset Count Register (WDOG_RSTCNT)	16	R/W	0000h	23.7.11/514
4005_2016	Watchdog Prescaler Register (WDOG_PRESC)	16	R/W	0400h	23.7.12/514

23.7.1 Watchdog Status and Control Register High (WDOG_STCTRLH)

Address: WDOG_STCTRLH is 4005_2000h base + 0h offset = 4005_2000h

Bit	15	14	13	12	11	10	9	8	7	6	5	4	3	2	1	0
Read	0	DISTESTWDOG	BYTESEL[1:0]	TESTSEL	TESTWDOG	0	STNDBYEN	WAITEN	STOPEN	DBGEN	ALLOWUPDATE	WINEN	IFQRSTEN	CLKSRC	WDOGEN	
Write																
Reset	0	0	0	0	0	0	0	1	1	1	0	1	0	0	1	1

WDOG_STCTRLH field descriptions

Field	Description
15 Reserved	This read-only field is reserved and always has the value zero.
14 DISTESTWDOG	Allows the WDOG's functional test mode to be disabled permanently. Once set, it can only be cleared by a reset. It cannot be unlocked for editing once it is set. 0 WDOG functional test mode is not disabled. 1 WDOG functional test mode is disabled permanently until reset.
13-12 BYTESEL[1:0]	This 2-bit field select the byte to be tested when the watchdog is in the byte test mode. 00 Byte 0 selected 01 Byte 1 selected 10 Byte 2 selected 11 Byte 3 selected
11 TESTSEL	Selects the test to be run on the watchdog timer. Effective only if TESTWDOG is set.

Table continues on the next page...

WDOG_STCTRLH field descriptions (continued)

Field	Description
	0 Quick test. The timer runs in normal operation. You can load a small time-out value to do a quick test. 1 Byte test. Puts the timer in the byte test mode where individual bytes of the timer are enabled for operation and are compared for time-out against the corresponding byte of the programmed time-out value. Select the byte through BYTESEL[1:0] for testing.
10 TESTWDOG	Puts the watchdog in the functional test mode. In this mode the watchdog timer and the associated compare and reset generation logic is tested for correct operation. The clock for the timer is switched from the main watchdog clock to the fast clock input for watchdog functional test. The TESTSEL bit selects the test to be run.
9 Reserved	This read-only field is reserved and always has the value zero.
8 STNDBYEN	Enables or disables WDOG in Standby mode. 0 WDOG is disabled in system Standby mode. 1 WDOG is enabled in system Standby mode.
7 WAITEN	Enables or disables WDOG in wait mode. 0 WDOG is disabled in CPU wait mode. 1 WDOG is enabled in CPU wait mode.
6 STOPEN	Enables or disables WDOG in stop mode. 0 WDOG is disabled in CPU stop mode. 1 WDOG is enabled in CPU stop mode.
5 DBGEN	Enables or disables WDOG in Debug mode. 0 WDOG is disabled in CPU Debug mode. 1 WDOG is enabled in CPU Debug mode.
4 ALLOWUPDATE	Enables updates to watchdog write once registers, after initial configuration window (WCT) closes, through unlock sequence. 0 No further updates allowed to WDOG write once registers. 1 WDOG write once registers can be unlocked for updating.
3 WINEN	Enable windowing mode. 0 Windowing mode is disabled. 1 Windowing mode is enabled.
2 IRQRSTEN	Used to enable the debug breadcrumbs feature. A change in this bit is updated immediately, as opposed to updating after WCT. 0 WDOG time-out generates reset only. 1 WDOG time-out initially generates an interrupt. After WCT time, it generates a reset.
1 CLKSRC	Selects clock source for the WDOG timer and other internal timing operations. 0 Dedicated clock source selected as WDOG clock (LPO Oscillator). 1 WDOG clock sourced from alternate clock source.
0 WDOGEN	Enables or disables the WDOG's operation. In the disabled state, the watchdog timer is kept in the reset state, but the other exception conditions can still trigger a reset/interrupt. A change in the value of this bit must be held for more than one WDOG_CLK cycle for the WDOG to be enabled or disabled.

Table continues on the next page...

WDOG_STCTRLH field descriptions (continued)

Field	Description
0	WDOG is disabled.
1	WDOG is enabled.

23.7.2 Watchdog Status and Control Register Low (WDOG_STCTRL)

Address: WDOG_STCTRL is 4005_2000h base + 2h offset = 4005_2002h

Bit	15	14	13	12	11	10	9	8	7	6	5	4	3	2	1	0
Read	Reserved															
Write	Reserved															
Reset	0	0	0	0	0	0	0	0	0	0	0	0	0	0	0	1

WDOG_STCTRL field descriptions

Field	Description
15 INTFLG	Interrupt flag. It is set when an exception occurs. IRQRSTEN = 1 is a precondition to set this flag. INTFLG = 1 results in an interrupt being issued followed by a reset, WCT time later. The interrupt can be cleared by writing 1 to this bit. It also gets cleared on a system reset.
14–0 Reserved	This field is reserved. NOTE: Do not modify this bitfield value.

23.7.3 Watchdog Time-out Value Register High (WDOG_TOVALH)

Address: WDOG_TOVALH is 4005_2000h base + 4h offset = 4005_2004h

Bit	15	14	13	12	11	10	9	8	7	6	5	4	3	2	1	0
Read	TOVALHIGH															
Write	TOVALHIGH															
Reset	0	0	0	0	0	0	0	0	0	1	0	0	1	1	0	0

WDOG_TOVALH field descriptions

Field	Description
15–0 TOVALHIGH	Defines the upper 16 bits of the 32-bit time-out value for the watchdog timer. It is defined in terms of cycles of the watchdog clock.

23.7.4 Watchdog Time-out Value Register Low (WDOG_TOVALL)

The time-out value of the watchdog must be set to a minimum of four watchdog clock cycles. This is to take into account the delay in new settings taking effect in the watchdog clock domain.

Address: WDOG_TOVALL is 4005_2000h base + 6h offset = 4005_2006h

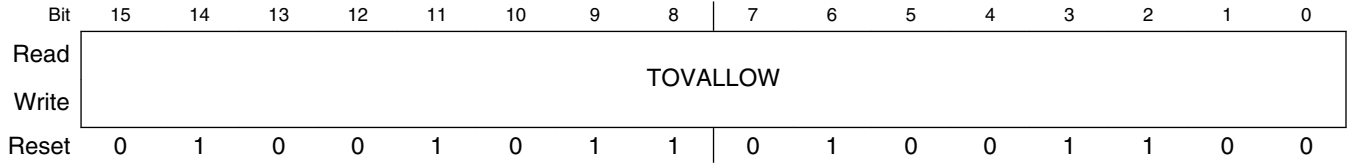

WDOG_TOVALL field descriptions

Field	Description
15–0 TOVALLOW	Defines the lower 16 bits of the 32-bit time-out value for the watchdog timer. It is defined in terms of cycles of the watchdog clock.

23.7.5 Watchdog Window Register High (WDOG_WINH)

You must set the Window Register value lower than the Time-out Value Register.

Address: WDOG_WINH is 4005_2000h base + 8h offset = 4005_2008h



WDOG_WINH field descriptions

Field	Description
15–0 WINHIGH	Defines the upper 16 bits of the 32-bit window for the windowed mode of operation of the watchdog. It is defined in terms of cycles of the watchdog clock. In this mode the watchdog can be refreshed only when the timer has reached a value greater than or equal to this window length. A refresh outside this window resets the system or if IRQRSTEN is set, it interrupts and then resets the system.

23.7.6 Watchdog Window Register Low (WDOG_WINL)

You must set the Window Register value lower than the Time-out Value Register.

Address: WDOG_WINL is 4005_2000h base + Ah offset = 4005_200Ah

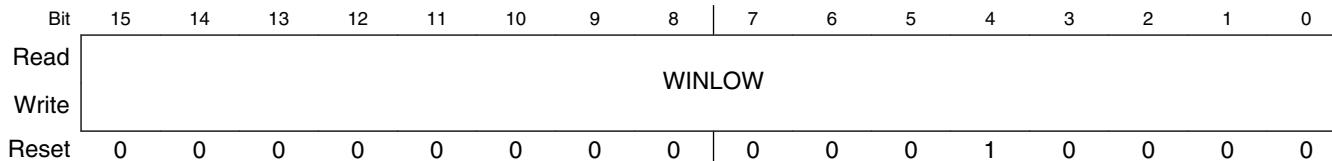

WDOG_WINL field descriptions

Field	Description
15–0 WINLOW	Defines the lower 16 bits of the 32-bit window for the windowed mode of operation of the watchdog. It is defined in terms of cycles of the pre-scaled watchdog clock. In this mode, the watchdog can be refreshed only when the timer reaches a value greater than or equal to this window length value. A refresh outside this window resets the system or if IRQRSTEN is set, it interrupts and then resets the system.

23.7.7 Watchdog Refresh Register (WDOG_REFRESH)

Address: WDOG_REFRESH is 4005_2000h base + Ch offset = 4005_200Ch



WDOG_REFRESH field descriptions

Field	Description
15–0 WDOGREFRESH	Watchdog refresh register. A sequence of 0xA602 followed by 0xB480 within 20 bus clock cycles when written to this register, refreshes the WDOG and prevents it from resetting the system. Writing a value other than the above mentioned sequence or if the sequence is longer than 20 bus cycles, resets the system or if IRQRSTEN is set, it interrupts and then resets the system).

23.7.8 Watchdog Unlock Register (WDOG_UNLOCK)

Address: WDOG_UNLOCK is 4005_2000h base + Eh offset = 4005_200Eh

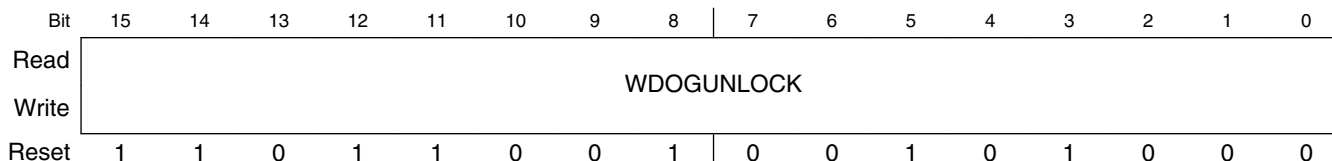

WDOG_UNLOCK field descriptions

Field	Description
15–0 WDOGUNLOCK	You can write the unlock sequence values to this register to make the watchdog write once registers writable again. The required unlock sequence is 0xC520 followed by 0xD928 within 20 bus clock cycles. A valid unlock sequence opens up a window equal in length to the WCT within which you can update the registers. Writing a value other than the above mentioned sequence or if the sequence is longer than 20 bus cycles, resets the system or if IRQRSTEN is set, it interrupts and then resets the system). The unlock sequence is effective only if ALLOWUPDATE is set.

23.7.9 Watchdog Timer Output Register High (WDOG_TMROUTH)

Address: WDOG_TMROUTH is 4005_2000h base + 10h offset = 4005_2010h

Bit	15	14	13	12	11	10	9	8	7	6	5	4	3	2	1	0
Read	TIMEROUTHIGH															
Write	TIMEROUTHIGH															
Reset	0	0	0	0	0	0	0	0	0	0	0	0	0	0	0	0

WDOG_TMROUTH field descriptions

Field	Description
15–0 TIMEROUTHIGH	Shows the value of the upper 16 bits of the watchdog timer.

23.7.10 Watchdog Timer Output Register Low (WDOG_TMROUTL)

During stop mode, the WDOG_TIMER_OUT will be caught at the pre-stop value of the watchdog timer. After exiting stop mode, a maximum delay of 1 WDOG_CLK cycle + 3 bus clock cycles will occur before the WDOG_TIMER_OUT starts following the watchdog timer.

Address: WDOG_TMROUTL is 4005_2000h base + 12h offset = 4005_2012h

Bit	15	14	13	12	11	10	9	8	7	6	5	4	3	2	1	0
Read	TIMEROULOW															
Write	TIMEROULOW															
Reset	0	0	0	0	0	0	0	0	0	0	0	0	0	0	0	0

WDOG_TMROUTL field descriptions

Field	Description
15–0 TIMEROULOW	Shows the value of the lower 16 bits of the watchdog timer.

23.7.11 Watchdog Reset Count Register (WDOG_RSTCNT)

Address: WDOG_RSTCNT is 4005_2000h base + 14h offset = 4005_2014h

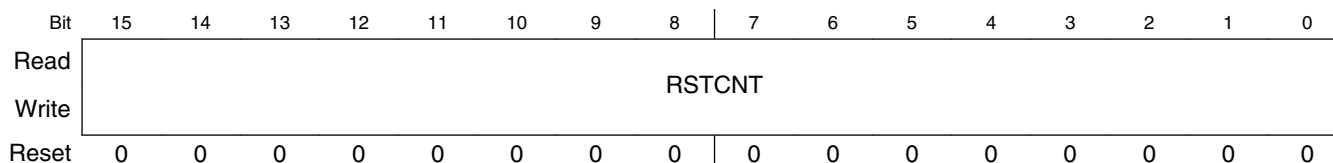

WDOG_RSTCNT field descriptions

Field	Description
15–0 RSTCNT	Counts the number of times the watchdog resets the system. This register is reset only on a POR. Writing 1 to the bit to be cleared, enables you to clear the contents of this register.

23.7.12 Watchdog Prescaler Register (WDOG_PRESC)

Address: WDOG_PRESC is 4005_2000h base + 16h offset = 4005_2016h

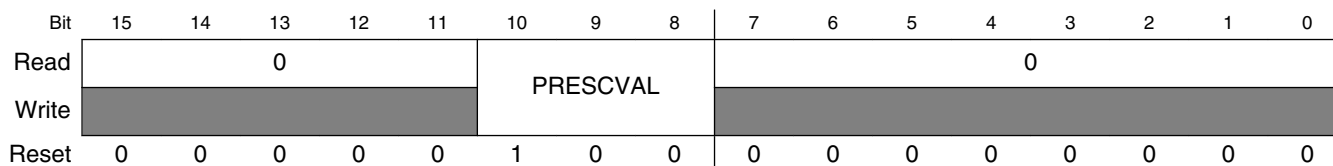

WDOG_PRESC field descriptions

Field	Description
15–11 Reserved	This read-only field is reserved and always has the value zero.
10–8 PRESCVAL	3-bit prescaler for the watchdog clock source. A value of zero indicates no division of the input WDOG clock. The watchdog clock is divided by (PRESCVAL + 1) to provide the prescaled WDOG_CLK.
7–0 Reserved	This read-only field is reserved and always has the value zero.

23.8 Watchdog Operation with 8-bit access

This section discusses 8-bit access considerations.

23.8.1 General Guideline

When performing 8-bit accesses to the watchdog's 16-bit registers where the intention is to access both the bytes of a register, you must try to place the two 8-bit accesses one after the other in your code.

23.8.2 Refresh and Unlock operations with 8-bit access

One exception condition that generates a reset to the system, is the write of any value other than those required for a legal refresh/update sequence to the respective refresh and unlock registers.

For an 8-bit access to these registers, writing a correct value requires at least two bus clock cycles that means there is an invalid value in the registers for one cycle. Therefore, the system is reset even if the intention is to write a correct value to the refresh/unlock register. Keeping this in mind the exception condition for 8-bit accesses is slightly modified. Whereas the match for a correct value for a refresh/unlock sequence is as per the original definition, the match for an incorrect value is done byte-wise on the refresh/unlock rather than for the whole 16-bit value. This means that if the high byte of the refresh/unlock register contains any value other than high bytes of the two values making up the sequence, it is treated as an exception condition, leading to a reset or interrupt-then-reset. The same holds true for the lower byte of the refresh or unlock register. Let us take the refresh operation that expects a write of 0xA602 followed by 0xB480 to the refresh register, as an example.

Table 23-14. Refresh for 8-bit Access

	WDOG_REFRESH[15:8]	WDOG_REFRESH[7:0]	Sequence value1 or value2 match	Mismatch exception
Current Value	0xB4	0x80	Value2 match	No
Write 1	0xB4	0x02	No match	No
Write 2	0xA6	0x02	Value1 match	No
Write 3	0xB4	0x02	No match	No
Write 4	0xB4	0x80	Value2 match. Sequence complete.	No
Write 5	0x02	0x80	No match	Yes

As shown in the preceding table, the refresh register holds its reset value initially. Thereafter, two 8-bit accesses are performed on the register to write the first value of the refresh sequence. No mismatch exception is registered on the intermediate write, Write1. The sequence is completed by performing two more 8-bit accesses, writing in the second value of the sequence for a successful refresh. It must be noted that the match of value2

takes place only when the complete 16-bit value is correctly written, write4. Hence, the requirement of writing value2 of the sequence within 20 bus clock cycles of value1 is checked by measuring the gap between write2 and write4.

It is reiterated that the condition for matching values 1 and 2 of the refresh or unlock sequence remains unchanged. It is just the criterion for detecting a wrong value in these registers which has been relaxed, as explained, for 8-bit accesses. Any 16-bit access still needs to adhere to the original guidelines, mentioned in the sections [Refreshing the Watchdog](#).

23.9 Restrictions on Watchdog Operation

This section mentions some exceptions to the watchdog operation that may not be apparent to you.

- **Restriction on unlock / refresh operations**—In the period between the closure of the WCT window (after unlock) and the actual reload of the watchdog timer, unlock and refresh operations need not be attempted.
- The update and reload of the watchdog timer happens two to three watchdog clocks after WCT window closes, following a successful configuration on unlock.
- **Clock Switching Delay**—The watchdog uses glitch free multiplexers at two places – one to choose between the LPO oscillator input and alternate clock input and the other to choose between the watchdog functional clock and fast clock input for watchdog functional test. A maximum time period of ~ 2 clock A cycles plus ~2 clock B cycles elapses from the time a switch is requested to the occurrence of the actual clock switch (clock A and B are the two input clocks to the clock mux).
- For the windowed mode, there is a two to three bus clock latency between the watchdog counter going past the window value and the same registering in the bus clock domain.
- For proper operation of the watchdog, the watchdog clock must be at least five times slower than the system bus clock at all times. An exception is the case when the watchdog clock is synchronous to the bus clock wherein the watchdog clock can be as fast as the bus clock.
- WCT must be equivalent to at least three watchdog clock cycles. If not ensured, this means that even after the close of the WCT window, you have to wait for the synchronized system reset to deassert in the watchdog clock domain, before expecting the configuration updates to take effect.

- The time-out value of the watchdog should be set to a minimum of four watchdog clock cycles. This is to take into account the delay in new settings taking effect in the watchdog clock domain.
- You must take care not only to refresh the watchdog within the watchdog timer's actual time-out period, but also provide enough allowance for the time it takes for the refresh sequence to be detected by the watchdog timer, on the watchdog clock.
- Updates cannot be made in the bus clock cycle immediately following the write of the unlock sequence, but one bus clock cycle later.
- It should be ensured that the time-out value for the watchdog is always greater than $2 \times \text{WCT time} + 20$ bus clock cycles.
- An attempted refresh operation, in between the two writes of the unlock sequence and in the WCT time following a successful unlock, will go undetected.
- Trying to unlock the watchdog within the WCT time after an initial unlock has no effect.
- The refresh and unlock operations and interrupt are not automatically disabled in the watchdog functional test mode.
- After emerging from a reset due to a watchdog functional test, you are still expected to go through the mandatory steps of unlocking and configuring the watchdog. The watchdog continues to be in its functional test mode and therefore you should pull the watchdog out of the functional test mode within WCT time of reset.
- After emerging from a reset due to a watchdog functional test, you still need to go through the mandatory steps of unlocking and configuring the watchdog.
- You must ensure that both the clock inputs to the glitchless clock multiplexers are alive during the switching of clocks. Failure to do so results in a loss of clock at their outputs.
- There is a gap of two to three watchdog clock cycles from the point that stop mode is entered to the watchdog timer actually pausing, due to synchronization. The same holds true for an exit from the stop mode, this time resulting in a two to three watchdog clock cycle delay in the timer restarting. In case the duration of the stop mode is less than one watchdog clock cycle, the watchdog timer is not guaranteed to pause.
- Consider the case when the first refresh value is written, following which the system enters stop mode (with system bus clk still on). Now, if the second refresh value is not written within 20 bus cycles of the first value, the system is reset (or interrupt-then-reset if enabled).

Chapter 24

Multipurpose Clock Generator (MCG)

24.1 Introduction

NOTE

For the chip-specific implementation details of this module's instances see the chip configuration chapter.

The multipurpose clock generator (MCG) module provides several clock source choices for the MCU. The module contains a frequency-locked loop (FLL) and a phase-locked loop (PLL). The FLL is controllable by either an internal or an external reference clock. The PLL is controllable by the external reference clock. The module can select either of the FLL or PLL output clocks, or either of the internal or external reference clocks as a source for the MCU system clock. The MCG operates in conjunction with a crystal oscillator, which allows an external crystal, ceramic resonator, or another external clock source to produce the external reference clock.

24.1.1 Features

Key features of the MCG module are:

- Frequency-locked loop (FLL)
 - Digitally-controlled oscillator (DCO)
 - DCO frequency range is programmable for up to four different frequency ranges.
 - Option to program and maximize DCO output frequency for a low frequency external reference clock source.
 - Option to prevent FLL from resetting its current locked frequency when switching clock modes if FLL reference frequency is not changed.

- Internal or external reference clock can be used as the FLL source.
- Can be used as a clock source for other on-chip peripherals.
- Phase-locked loop (PLL)
 - Voltage-controlled oscillator (VCO)
 - External reference clock is used as the PLL source
 - Modulo VCO frequency divider
 - Phase/Frequency detector
 - Integrated loop filter
 - Can be used as a clock source for other on-chip peripherals.
- Internal reference clock generator
 - Slow clock with nine trim bits for accuracy
 - Fast clock with four trim bits
 - Can be used as source clock for the FLL. In FEI mode, only the slow Internal Reference Clock (IRC) can be used as the FLL source.
 - Either the slow or the fast clock can be selected as the clock source for the MCU
 - Can be used as a clock source for other on-chip peripherals
- Control signals for "the MCG external reference low power oscillator clock generators are provided:
 - HGO, RANGE, EREFS
- External clock from the Crystal Oscillator
 - Can be used as a source for the FLL and/or the PLL.
 - Can be selected as the clock source for the MCU
- External clock from the Real Time Counter (RTC)
 - Can only be used as a source for the FLL.
 - Can be selected as the clock source for the MCU
- External clock monitor with reset and interrupt request capability to check for external clock failure when running in FBE, PEE, BLPE, or FEE modes
- Lock detector with interrupt request capability for use with the PLL

- Internal Reference Clocks Auto Trim Machine (ATM) capability using an external clock as a reference
- Reference dividers for both the FLL and PLL are provided
- Reference dividers for the Fast Internal Reference Clock are provided
- MCG PLL Clock (MCGPLLCLK) is provided as a clock source for other on-chip peripherals
- MCG FLL Clock (MCGFLLCLK) is provided as a clock source for other on-chip peripherals
- MCG Fixed Frequency Clock (MCGFFCLK) is provided as a clock source for other on-chip peripherals
- MCG Internal Reference Clock (MCGIRCLK) is provided as a clock source for other on-chip peripherals.

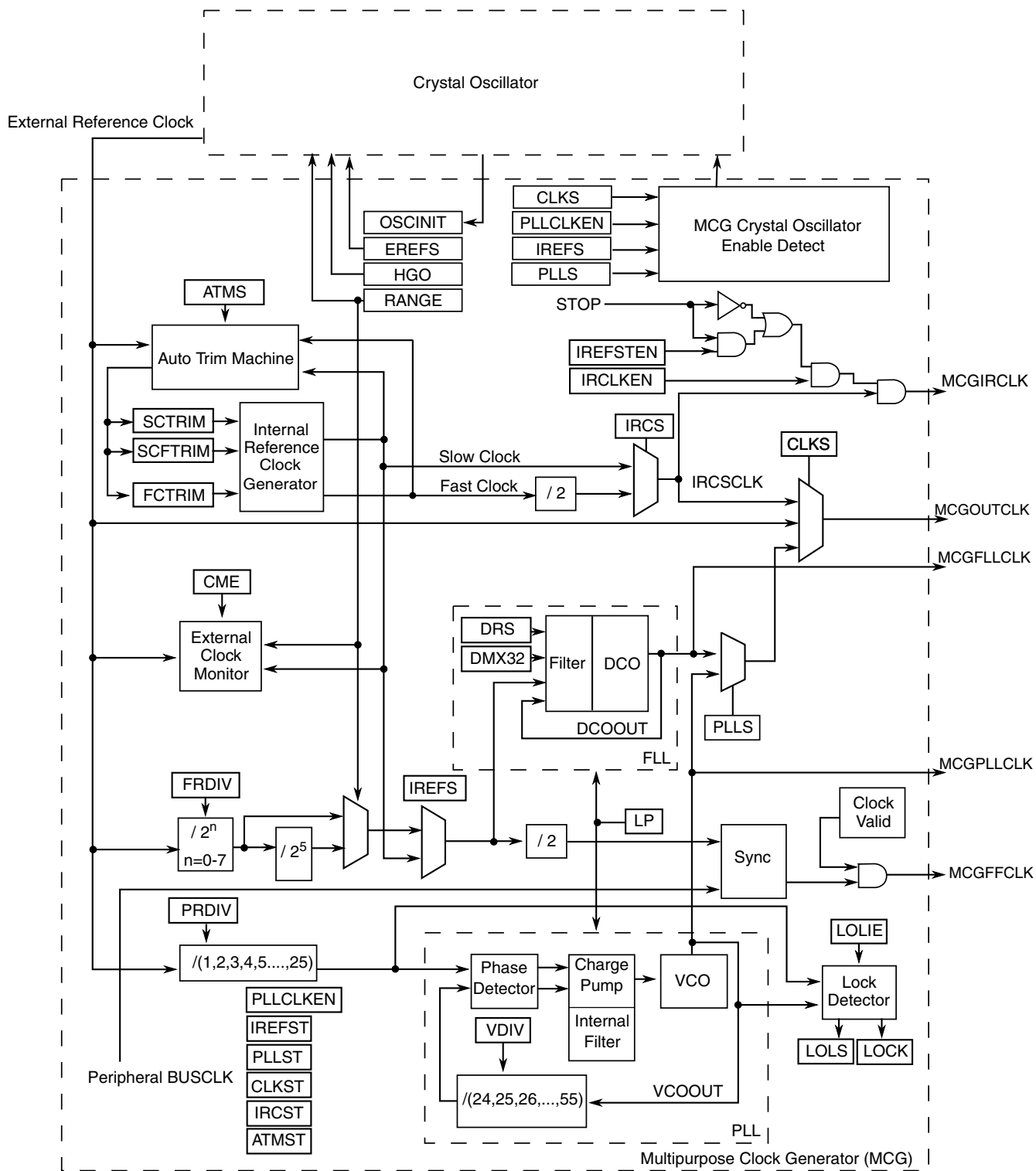

Figure 24-1. Multipurpose Clock Generator (MCG) Block Diagram

24.1.2 Modes of Operation

There are nine modes of operation for the MCG: FEI, FEE, FBI, FBE, PBE, PEE, BLPI, BLPE, and Stop. For details, see [MCG Modes of Operation](#).

24.2 External Signal Description

There are no MCG signals that connect off chip.

24.3 Memory Map/Register Definition

This section includes the memory map and register definition.

The MCG registers can only be written to when in supervisor mode. Write accesses when in user mode will result in a bus error. Read accesses may be performed in both supervisor and user modes.

MCG memory map

Absolute address (hex)	Register name	Width (in bits)	Access	Reset value	Section/page
4006_4000	MCG Control 1 Register (MCG_C1)	8	R/W	04h	24.3.1/524
4006_4001	MCG Control 2 Register (MCG_C2)	8	R/W	See section	24.3.2/525
4006_4002	MCG Control 3 Register (MCG_C3)	8	R/W	Undefined	24.3.3/526
4006_4003	MCG Control 4 Register (MCG_C4)	8	R/W	Undefined	24.3.4/527
4006_4004	MCG Control 5 Register (MCG_C5)	8	R/W	00h	24.3.5/528
4006_4005	MCG Control 6 Register (MCG_C6)	8	R/W	00h	24.3.6/530
4006_4006	MCG Status Register (MCG_S)	8	R	10h	24.3.7/531
4006_4008	MCG Auto Trim Control Register (MCG_ATC)	8	R/W	00h	24.3.8/533
4006_400A	MCG Auto Trim Compare Value High Register (MCG_ATCVH)	8	R/W	00h	24.3.9/533
4006_400B	MCG Auto Trim Compare Value Low Register (MCG_ATCVL)	8	R/W	00h	24.3.10/534

24.3.1 MCG Control 1 Register (MCG_C1)

Address: MCG_C1 is 4006_4000h base + 0h offset = 4006_4000h

Bit	7	6	5	4	3	2	1	0
Read	CLKS		FRDIV			IREFS	IRCLKEN	IREFSTEN
Write	CLKS		FRDIV			IREFS	IRCLKEN	IREFSTEN
Reset	0	0	0	0	0	1	0	0

MCG_C1 field descriptions

Field	Description
7–6 CLKS	<p>Clock Source Select</p> <p>Selects the clock source for MCGOUTCLK .</p> <p>00 Encoding 0 — Output of FLL or PLL is selected (depends on PLLS control bit).</p> <p>01 Encoding 1 — Internal reference clock is selected.</p> <p>10 Encoding 2 — External reference clock is selected.</p> <p>11 Encoding 3 — Reserved, defaults to 00.</p>
5–3 FRDIV	<p>FLL External Reference Divider</p> <p>Selects the amount to divide down the external reference clock for the FLL. The resulting frequency must be in the range 31.25 kHz to 39.0625 kHz (This is required when FLL/DCO is the clock source for MCGOUTCLK . In FBE mode, it is not required to meet this range, but it is recommended in the cases when trying to enter a FLL mode from FBE).</p> <p>000 If RANGE = 0 , Divide Factor is 1; for all other RANGE values, Divide Factor is 32.</p> <p>001 If RANGE = 0 , Divide Factor is 2; for all other RANGE values, Divide Factor is 64.</p> <p>010 If RANGE = 0 , Divide Factor is 4; for all other RANGE values, Divide Factor is 128.</p> <p>011 If RANGE = 0 , Divide Factor is 8; for all other RANGE values, Divide Factor is 256.</p> <p>100 If RANGE = 0 , Divide Factor is 16; for all other RANGE values, Divide Factor is 512.</p> <p>101 If RANGE = 0 , Divide Factor is 32; for all other RANGE values, Divide Factor is 1024.</p> <p>110 If RANGE = 0 , Divide Factor is 64; for all other RANGE values, Divide Factor is Reserved .</p> <p>111 If RANGE = 0 , Divide Factor is 128; for all other RANGE values, Divide Factor is Reserved .</p>
2 IREFS	<p>Internal Reference Select</p> <p>Selects the reference clock source for the FLL.</p> <p>0 External reference clock is selected.</p> <p>1 The slow internal reference clock is selected.</p>
1 IRCLKEN	<p>Internal Reference Clock Enable</p> <p>Enables the internal reference clock for use as MCGIRCLK.</p> <p>0 MCGIRCLK inactive.</p> <p>1 MCGIRCLK active.</p>
0 IREFSTEN	<p>Internal Reference Stop Enable</p> <p>Controls whether or not the internal reference clock remains enabled when the MCG enters Stop mode.</p>

Table continues on the next page...

MCG_C1 field descriptions (continued)

Field	Description
0	Internal reference clock is disabled in Stop mode.
1	Internal reference clock is enabled in Stop mode if IRCLKEN is set or if MCG is in FEI, FBI, or BLPI modes before entering Stop mode.

24.3.2 MCG Control 2 Register (MCG_C2)

Address: MCG_C2 is 4006_4000h base + 1h offset = 4006_4001h

Bit	7	6	5	4	3	2	1	0
Read	0	0	RANGE		HGO	EREFS	LP	IRCS
Write								
Reset	0	0	0	0	0	0	0	0

MCG_C2 field descriptions

Field	Description
7 Reserved	This read-only field is reserved and always has the value zero.
6 Reserved	This read-only field is reserved and always has the value zero.
5-4 RANGE	<p>Frequency Range Select</p> <p>Selects the frequency range for the crystal oscillator or external clock source. Refer to the Oscillator (OSC) chapter for more details and the device data sheet for the frequency ranges used.</p> <p>00 Encoding 0 — Low frequency range selected for the crystal oscillator .</p> <p>01 Encoding 1 — High frequency range selected for the crystal oscillator .</p> <p>1X Encoding 2 — Very high frequency range selected for the crystal oscillator .</p>
3 HGO	<p>High Gain Oscillator Select</p> <p>Controls the crystal oscillator mode of operation. Refer to the Oscillator (OSC) chapter for more details.</p> <p>0 Configure crystal oscillator for low-power operation.</p> <p>1 Configure crystal oscillator for high-gain operation.</p>
2 EREFS	<p>External Reference Select</p> <p>Selects the source for the external reference clock. Refer to the Oscillator (OSC) chapter for more details.</p> <p>0 External reference clock requested.</p> <p>1 Oscillator requested.</p>
1 LP	<p>Low Power Select</p> <p>Controls whether the FLL (or PLL) is disabled in BLPI and BLPE modes. In FBE or PBE modes, setting this bit to 1 will transition the MCG into BLPE mode; in FBI mode, setting this bit to 1 will transition the MCG into BLPI mode. In any other MCG mode, LP bit has no affect.</p>

Table continues on the next page...

MCG_C2 field descriptions (continued)

Field	Description
	0 FLL (or PLL) is not disabled in bypass modes. 1 FLL (or PLL) is disabled in bypass modes (lower power)
0 IRCS	Internal Reference Clock Select Selects between the fast or slow internal reference clock source. 0 Slow internal reference clock selected. 1 Fast internal reference clock selected.

24.3.3 MCG Control 3 Register (MCG_C3)

Address: MCG_C3 is 4006_4000h base + 2h offset = 4006_4002h

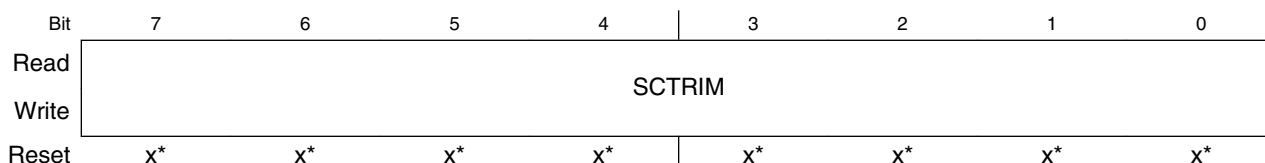

* Notes:

- x = Undefined at reset.

MCG_C3 field descriptions

Field	Description
7-0 SCTRIM	Slow Internal Reference Clock Trim Setting SCTRIM ¹ controls the slow internal reference clock frequency by controlling the slow internal reference clock period. The SCTRIM bits are binary weighted (that is, bit 1 adjusts twice as much as bit 0). Increasing the binary value increases the period, and decreasing the value decreases the period. An additional fine trim bit is available in C4 register as the SCFTRIM bit. Upon reset this value is loaded with a factory trim value. If an SCTRIM value stored in nonvolatile memory is to be used, it is your responsibility to copy that value from the nonvolatile memory location to this register.

1. A value for SCTRIM is loaded during reset from a factory programmed location .

24.3.4 MCG Control 4 Register (MCG_C4)

Reset values for DRST and DMX32 bits are 0.

Address: MCG_C4 is 4006_4000h base + 3h offset = 4006_4003h

Bit	7	6	5	4	3	2	1	0
Read	DMX32		DRST_DRS		FCTRIM			SCFTRIM
Write	DMX32		DRST_DRS		FCTRIM			SCFTRIM
Reset	0	0	0	x*	x*	x*	x*	x*

* Notes:

- x = Undefined at reset.
- A value for FCTRIM is loaded during reset from a factory programmed location . x = Undefined at reset.

MCG_C4 field descriptions

Field	Description																																									
7 DMX32	<p>DCO Maximum Frequency with 32.768 kHz Reference</p> <p>The DMX32 bit controls whether or not the DCO frequency range is narrowed to its maximum frequency with a 32.768 kHz reference.</p> <p>The following table identifies settings for the DCO frequency range.</p> <p>NOTE: The system clocks derived from this source should not exceed their specified maximums.</p> <table border="1"> <thead> <tr> <th>DRST_DRS</th> <th>DMX32</th> <th>Reference Range</th> <th>FLL Factor</th> <th>DCO Range</th> </tr> </thead> <tbody> <tr> <td rowspan="2">00</td> <td>0</td> <td>31.25-39.0625 kHz</td> <td>640</td> <td>20-25 MHz</td> </tr> <tr> <td>1</td> <td>32.768 kHz</td> <td>732</td> <td>24 MHz</td> </tr> <tr> <td rowspan="2">01</td> <td>0</td> <td>31.25-39.0625 kHz</td> <td>1280</td> <td>40-50 MHz</td> </tr> <tr> <td>1</td> <td>32.768 kHz</td> <td>1464</td> <td>48 MHz</td> </tr> <tr> <td rowspan="2">10</td> <td>0</td> <td>31.25-39.0625 kHz</td> <td>1920</td> <td>60-75 MHz</td> </tr> <tr> <td>1</td> <td>32.768 kHz</td> <td>2197</td> <td>72 MHz</td> </tr> <tr> <td rowspan="2">11</td> <td>0</td> <td>31.25-39.0625 kHz</td> <td>2560</td> <td>80-100 MHz</td> </tr> <tr> <td>1</td> <td>32.768 kHz</td> <td>2929</td> <td>96 MHz</td> </tr> </tbody> </table> <p>0 DCO has a default range of 25%. 1 DCO is fine-tuned for maximum frequency with 32.768 kHz reference.</p>	DRST_DRS	DMX32	Reference Range	FLL Factor	DCO Range	00	0	31.25-39.0625 kHz	640	20-25 MHz	1	32.768 kHz	732	24 MHz	01	0	31.25-39.0625 kHz	1280	40-50 MHz	1	32.768 kHz	1464	48 MHz	10	0	31.25-39.0625 kHz	1920	60-75 MHz	1	32.768 kHz	2197	72 MHz	11	0	31.25-39.0625 kHz	2560	80-100 MHz	1	32.768 kHz	2929	96 MHz
DRST_DRS	DMX32	Reference Range	FLL Factor	DCO Range																																						
00	0	31.25-39.0625 kHz	640	20-25 MHz																																						
	1	32.768 kHz	732	24 MHz																																						
01	0	31.25-39.0625 kHz	1280	40-50 MHz																																						
	1	32.768 kHz	1464	48 MHz																																						
10	0	31.25-39.0625 kHz	1920	60-75 MHz																																						
	1	32.768 kHz	2197	72 MHz																																						
11	0	31.25-39.0625 kHz	2560	80-100 MHz																																						
	1	32.768 kHz	2929	96 MHz																																						
6-5 DRST_DRS	<p>DCO Range Select</p> <p>The DRS bits select the frequency range for the FLL output, DCOOUT. When the LP bit is set, writes to the DRS bits are ignored. The DRST read field indicates the current frequency range for DCOOUT. The DRST field does not update immediately after a write to the DRS field due to internal synchronization between clock domains. Refer to DCO Frequency Range table for more details.</p> <p>00 Encoding 0 — Low range (reset default). 01 Encoding 1 — Mid range.</p>																																									

Table continues on the next page...

MCG_C4 field descriptions (continued)

Field	Description
	10 Encoding 2 — Mid-high range. 11 Encoding 3 — High range.
4–1 FCTRIM	Fast Internal Reference Clock Trim Setting FCTRIM ¹ controls the fast internal reference clock frequency by controlling the fast internal reference clock period. The FCTRIM bits are binary weighted (that is, bit 1 adjusts twice as much as bit 0). Increasing the binary value increases the period, and decreasing the value decreases the period. If an FCTRIM[3:0] value stored in nonvolatile memory is to be used, it is your responsibility to copy that value from the nonvolatile memory location to this register.
0 SCFTRIM	Slow Internal Reference Clock Fine Trim SCFTRIM ² controls the smallest adjustment of the slow internal reference clock frequency. Setting SCFTRIM increases the period and clearing SCFTRIM decreases the period by the smallest amount possible. If an SCFTRIM value stored in nonvolatile memory is to be used, it is your responsibility to copy that value from the nonvolatile memory location to this bit.

1. A value for FCTRIM is loaded during reset from a factory programmed location .
2. A value for SCFTRIM is loaded during reset from a factory programmed location .

24.3.5 MCG Control 5 Register (MCG_C5)

Address: MCG_C5 is 4006_4000h base + 4h offset = 4006_4004h

Bit	7	6	5	4	3	2	1	0
Read	0	PLLCLKEN	PLLSTEN			PRDIV		
Write		PLLCLKEN	PLLSTEN			PRDIV		
Reset	0	0	0	0	0	0	0	0

MCG_C5 field descriptions

Field	Description
7 Reserved	This read-only field is reserved and always has the value zero.
6 PLLCLKEN	PLL Clock Enable Enables the PLL independent of PLLS and enables the PLL clock for use as MCGPLLCLK. (PRDIV needs to be programmed to the correct divider to generate a PLL reference clock in the range of 2 - 4 MHz range prior to setting the PLLCLKEN bit). Setting PLLCLKEN will enable the external oscillator if not already enabled. Whenever the PLL is being enabled by means of the PLLCLKEN bit, and the external oscillator is being used as the reference clock, the OSCINIT bit should be checked to make sure it is set.

Table continues on the next page...

MCG_C5 field descriptions (continued)

Field	Description																																																																																																			
	0 MCGPLLCLK is inactive. 1 MCGPLLCLK is active.																																																																																																			
5 PLLSTEN	PLL Stop Enable Enables the PLL Clock during Normal Stop (In Low Power Stop mode, the PLL clock gets disabled even if PLLSTEN =1). All other power modes, PLLSTEN bit has no affect and does not enable the PLL Clock to run if it is written to 1. 0 MCGPLLCLK is disabled in any of the Stop modes. 1 MCGPLLCLK is enabled if system is in Normal Stop mode.																																																																																																			
4-0 PRDIV	PLL External Reference Divider Selects the amount to divide down the external reference clock for the PLL. The resulting frequency must be in the range of 2 MHz to 4 MHz. After the PLL is enabled (by setting either PLLCLKEN or PLLS), the PRDIV value must not be changed when LOCK is zero. <p style="text-align: center;">Table 24-7. PLL External Reference Divide Factor</p> <table border="1" style="width: 100%; border-collapse: collapse;"> <thead> <tr> <th>PRDIV</th> <th>Divide Factor</th> <th></th> <th>PRDIV</th> <th>Divide Factor</th> <th></th> <th>PRDIV</th> <th>Divide Factor</th> <th></th> <th>PRDIV</th> <th>Divide Factor</th> </tr> </thead> <tbody> <tr> <td>00000</td> <td>1</td> <td></td> <td>01000</td> <td>9</td> <td></td> <td>10000</td> <td>17</td> <td></td> <td>11000</td> <td>25</td> </tr> <tr> <td>00001</td> <td>2</td> <td></td> <td>01001</td> <td>10</td> <td></td> <td>10001</td> <td>18</td> <td></td> <td>11001</td> <td>Reserv ed</td> </tr> <tr> <td>00010</td> <td>3</td> <td></td> <td>01010</td> <td>11</td> <td></td> <td>10010</td> <td>19</td> <td></td> <td>11010</td> <td>Reserv ed</td> </tr> <tr> <td>00011</td> <td>4</td> <td></td> <td>01011</td> <td>12</td> <td></td> <td>10011</td> <td>20</td> <td></td> <td>11011</td> <td>Reserv ed</td> </tr> <tr> <td>00100</td> <td>5</td> <td></td> <td>01100</td> <td>13</td> <td></td> <td>10100</td> <td>21</td> <td></td> <td>11100</td> <td>Reserv ed</td> </tr> <tr> <td>00101</td> <td>6</td> <td></td> <td>01101</td> <td>14</td> <td></td> <td>10101</td> <td>22</td> <td></td> <td>11101</td> <td>Reserv ed</td> </tr> <tr> <td>00110</td> <td>7</td> <td></td> <td>01110</td> <td>15</td> <td></td> <td>10110</td> <td>23</td> <td></td> <td>11110</td> <td>Reserv ed</td> </tr> <tr> <td>00111</td> <td>8</td> <td></td> <td>01111</td> <td>16</td> <td></td> <td>10111</td> <td>24</td> <td></td> <td>11111</td> <td>Reserv ed</td> </tr> </tbody> </table>	PRDIV	Divide Factor		PRDIV	Divide Factor		PRDIV	Divide Factor		PRDIV	Divide Factor	00000	1		01000	9		10000	17		11000	25	00001	2		01001	10		10001	18		11001	Reserv ed	00010	3		01010	11		10010	19		11010	Reserv ed	00011	4		01011	12		10011	20		11011	Reserv ed	00100	5		01100	13		10100	21		11100	Reserv ed	00101	6		01101	14		10101	22		11101	Reserv ed	00110	7		01110	15		10110	23		11110	Reserv ed	00111	8		01111	16		10111	24		11111	Reserv ed
PRDIV	Divide Factor		PRDIV	Divide Factor		PRDIV	Divide Factor		PRDIV	Divide Factor																																																																																										
00000	1		01000	9		10000	17		11000	25																																																																																										
00001	2		01001	10		10001	18		11001	Reserv ed																																																																																										
00010	3		01010	11		10010	19		11010	Reserv ed																																																																																										
00011	4		01011	12		10011	20		11011	Reserv ed																																																																																										
00100	5		01100	13		10100	21		11100	Reserv ed																																																																																										
00101	6		01101	14		10101	22		11101	Reserv ed																																																																																										
00110	7		01110	15		10110	23		11110	Reserv ed																																																																																										
00111	8		01111	16		10111	24		11111	Reserv ed																																																																																										

24.3.6 MCG Control 6 Register (MCG_C6)

Address: MCG_C6 is 4006_4000h base + 5h offset = 4006_4005h

Bit	7	6	5	4	3	2	1	0
Read								
Write	LOLIE	PLLS	CME			VDIV		
Reset	0	0	0	0	0	0	0	0

MCG_C6 field descriptions

Field	Description																
7 LOLIE	<p>Loss of Lock Interrupt Enable</p> <p>Determines if an interrupt request is made following a loss of lock indication. This bit only has an effect when LOLS is set.</p> <p>0 No interrupt request is generated on loss of lock. 1 Generate an interrupt request on loss of lock.</p>																
6 PLLS	<p>PLL Select</p> <p>Controls whether the PLL or FLL output is selected as the MCG source when CLKS[1:0]=00. If the PLLS bit is cleared and PLLCLKEN is not set, the PLL is disabled in all modes. If the PLLS is set, the FLL is disabled in all modes.</p> <p>0 FLL is selected. 1 PLL is selected (PRDIV need to be programmed to the correct divider to generate a PLL reference clock in the range of 2 - 4 MHz prior to setting the PLLS bit).</p>																
5 CME	<p>Clock Monitor Enable</p> <p>Determines if a reset request is made following a loss of external clock indication. The CME bit should only be set to a logic 1 when the MCG is in an operational mode that uses the external clock (FEE, FBE, PEE, PBE, or BLPE). Whenever the CME bit is set to a logic 1, the value of the RANGE bits in the C2 register should not be changed. CME bit should be set to a logic 0 before the MCG enters any Stop mode. Otherwise, a reset request may occur while in Stop mode. CME should also be set to a logic 0 before entering VLPR or VLPW power modes if the MCG is in BLPE mode.</p> <p>0 External clock monitor is disabled. 1 Generate a reset request on loss of external clock.</p>																
4-0 VDIV	<p>VCO Divider</p> <p>Selects the amount to divide the VCO output of the PLL. The VDIV bits establish the multiplication factor (M) applied to the reference clock frequency. After the PLL is enabled (by setting either PLLCLKEN or PLLS), the VDIV value must not be changed when LOCK is zero.</p> <p style="text-align: center;">Table 24-9. PLL VCO Divide Factor</p> <table border="1" style="width: 100%; border-collapse: collapse;"> <thead> <tr> <th>VDIV</th> <th>Multiply Factor</th> <th>VDIV</th> <th>Multiply Factor</th> <th>VDIV</th> <th>Multiply Factor</th> <th>VDIV</th> <th>Multiply Factor</th> </tr> </thead> <tbody> <tr> <td>00000</td> <td>24</td> <td>01000</td> <td>32</td> <td>10000</td> <td>40</td> <td>11000</td> <td>48</td> </tr> </tbody> </table>	VDIV	Multiply Factor	VDIV	Multiply Factor	VDIV	Multiply Factor	VDIV	Multiply Factor	00000	24	01000	32	10000	40	11000	48
VDIV	Multiply Factor	VDIV	Multiply Factor	VDIV	Multiply Factor	VDIV	Multiply Factor										
00000	24	01000	32	10000	40	11000	48										

Table continues on the next page...

MCG_C6 field descriptions (continued)

Field	Description										
Table 24-9. PLL VCO Divide Factor (continued)											
	00001	25		01001	33		10001	41		11001	49
	00010	26		01010	34		10010	42		11010	50
	00011	27		01011	35		10011	43		11011	51
	00100	28		01100	36		10100	44		11100	52
	00101	29		01101	37		10101	45		11101	53
	00110	30		01110	38		10110	46		11110	54
	00111	31		01111	39		10111	47		11111	55

24.3.7 MCG Status Register (MCG_S)

Address: MCG_S is 4006_4000h base + 6h offset = 4006_4006h

Bit	7	6	5	4	3	2	1	0
Read	LOLS	LOCK	PLLST	IREFST	CLKST		OSCINIT	IRCST
Write								
Reset	0	0	0	1	0	0	0	0

MCG_S field descriptions

Field	Description
7 LOLS	<p>Loss of Lock Status</p> <p>This bit is a sticky bit indicating the lock status for the PLL. LOLS is set if after acquiring lock, the PLL output frequency has fallen outside the lock exit frequency tolerance, D_{unl}. LOLIE determines whether an interrupt request is made when LOLS is set. LOLRE determines whether a reset request is made when LOLS0 is set. This bit is cleared by reset or by writing a logic 1 to it when set. Writing a logic 0 to this bit has no effect.</p> <p>0 PLL has not lost lock since LOLS was last cleared. 1 PLL has lost lock since LOLS was last cleared.</p>
6 LOCK	<p>Lock Status</p> <p>This bit indicates whether the PLL has acquired lock. Lock detection is disabled when not operating in either PBE or PEE mode unless PLLCLKEN = 1 and the MCG is not configured in BLPI or BLPE mode.</p>

Table continues on the next page...

MCG_S field descriptions (continued)

Field	Description
	<p>While the PLL clock is locking to the desired frequency, the MCG PLL clock (MCGPLLCLK) will be gated off until the LOCK bit gets asserted. If the lock status bit is set, changing the value of the PRDIV [4:0] bits in the C5 register or the VDIV0[4:0] bits in the C6 register causes the lock status bit to clear and stay cleared until the PLL has reacquired lock. Entry into LLS, VLPS, or regular Stop with PLLSTEN =0 also causes the lock status bit to clear and stay cleared until the Stop mode is exited and the PLL has reacquired lock. Any time the PLL is enabled and the LOCK bit is cleared, the MCGPLLCLK will be gated off until the LOCK bit is asserted again.</p> <p>0 PLL is currently unlocked. 1 PLL is currently locked.</p>
5 PLLST	<p>PLL Select Status</p> <p>This bit indicates the clock source selected by PLLS . The PLLST bit does not update immediately after a write to the PLLS bit due to internal synchronization between clock domains.</p> <p>0 Source of PLLS clock is FLL clock. 1 Source of PLLS clock is PLL clock.</p>
4 IREFST	<p>Internal Reference Status</p> <p>This bit indicates the current source for the FLL reference clock. The IREFST bit does not update immediately after a write to the IREFS bit due to internal synchronization between clock domains.</p> <p>0 Source of FLL reference clock is the external reference clock. 1 Source of FLL reference clock is the internal reference clock.</p>
3-2 CLKST	<p>Clock Mode Status</p> <p>These bits indicate the current clock mode. The CLKST bits do not update immediately after a write to the CLKS bits due to internal synchronization between clock domains.</p> <p>00 Encoding 0 — Output of the FLL is selected (reset default). 01 Encoding 1 — Internal reference clock is selected. 10 Encoding 2 — External reference clock is selected. 11 Encoding 3 — Output of the PLL is selected.</p>
1 OSCINIT	<p>OSC Initialization</p> <p>This bit, which resets to 0, is set to 1 after the initialization cycles of the crystal oscillator clock have completed. After being set, the bit is cleared to 0 if the OSC is subsequently disabled. Refer to the OSC module's detailed description for more information.</p>
0 IRCST	<p>Internal Reference Clock Status</p> <p>The IRCST bit indicates the current source for the internal reference clock select clock (IRCSCCLK). The IRCST bit does not update immediately after a write to the IRCS bit due to internal synchronization between clock domains. The IRCST bit will only be updated if the internal reference clock is enabled, either by the MCG being in a mode that uses the IRC or by setting the C1[IRCLKEN] bit .</p> <p>0 Source of internal reference clock is the slow clock (32 kHz IRC). 1 Source of internal reference clock is the fast clock (2 MHz IRC).</p>

24.3.8 MCG Auto Trim Control Register (MCG_ATC)

Address: MCG_ATC is 4006_4000h base + 8h offset = 4006_4008h



MCG_ATC field descriptions

Field	Description
7 ATME	<p>Automatic Trim Machine Enable</p> <p>Enables the Auto Trim Machine to start automatically trimming the selected Internal Reference Clock.</p> <p>NOTE: ATME deasserts after the Auto Trim Machine has completed trimming all trim bits of the IRCS clock selected by the ATMS bit.</p> <p>Writing to C1, C3, C4, and ATC registers or entering Stop mode aborts the auto trim operation and clears this bit.</p> <p>0 Auto Trim Machine disabled. 1 Auto Trim Machine enabled.</p>
6 ATMS	<p>Automatic Trim Machine Select</p> <p>Selects the IRCS clock for Auto Trim Test.</p> <p>0 32 kHz Internal Reference Clock selected. 1 4 MHz Internal Reference Clock selected.</p>
5 ATMF	<p>Automatic Trim machine Fail Flag</p> <p>Fail flag for the Automatic Trim Machine (ATM). This bit asserts when the Automatic Trim Machine is enabled (ATME=1) and a write to the C1, C3, C4, and ATC registers is detected or the MCG enters into any Stop mode. A write to ATMF clears the flag.</p> <p>0 Automatic Trim Machine completed normally. 1 Automatic Trim Machine failed.</p>
4-0 Reserved	This read-only field is reserved and always has the value zero.

24.3.9 MCG Auto Trim Compare Value High Register (MCG_ATCVH)

Address: MCG_ATCVH is 4006_4000h base + Ah offset = 4006_400Ah

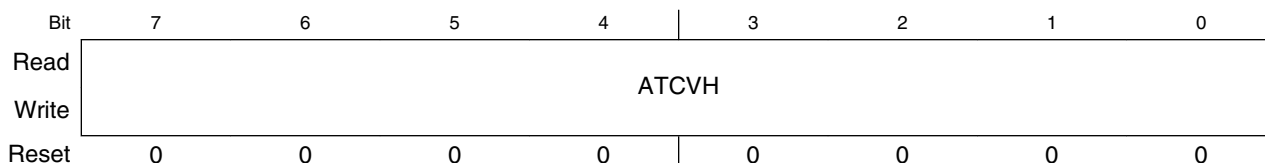

MCG_ATCVH field descriptions

Field	Description
7-0 ATCVH	ATM Compare Value High Values are used by Auto Trim Machine to compare and adjust Internal Reference trim values during ATM SAR conversion.

24.3.10 MCG Auto Trim Compare Value Low Register (MCG_ATCVL)

Address: MCG_ATCVL is 4006_4000h base + Bh offset = 4006_400Bh

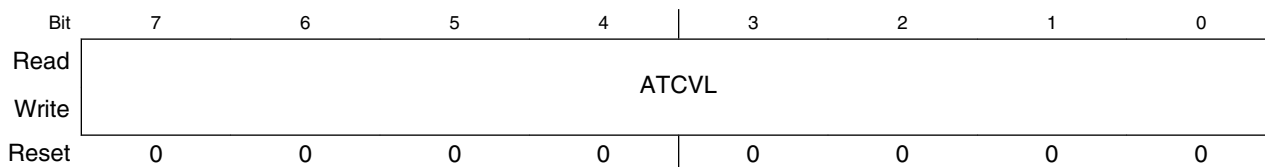

MCG_ATCVL field descriptions

Field	Description
7-0 ATCVL	ATM Compare Value Low Values are used by Auto Trim Machine to compare and adjust Internal Reference trim values during ATM SAR conversion.

24.4 Functional Description

24.4.1 MCG Mode State Diagram

The nine states of the MCG are shown in the following figure and are described in [Table 24-14](#). The arrows indicate the permitted MCG mode transitions.

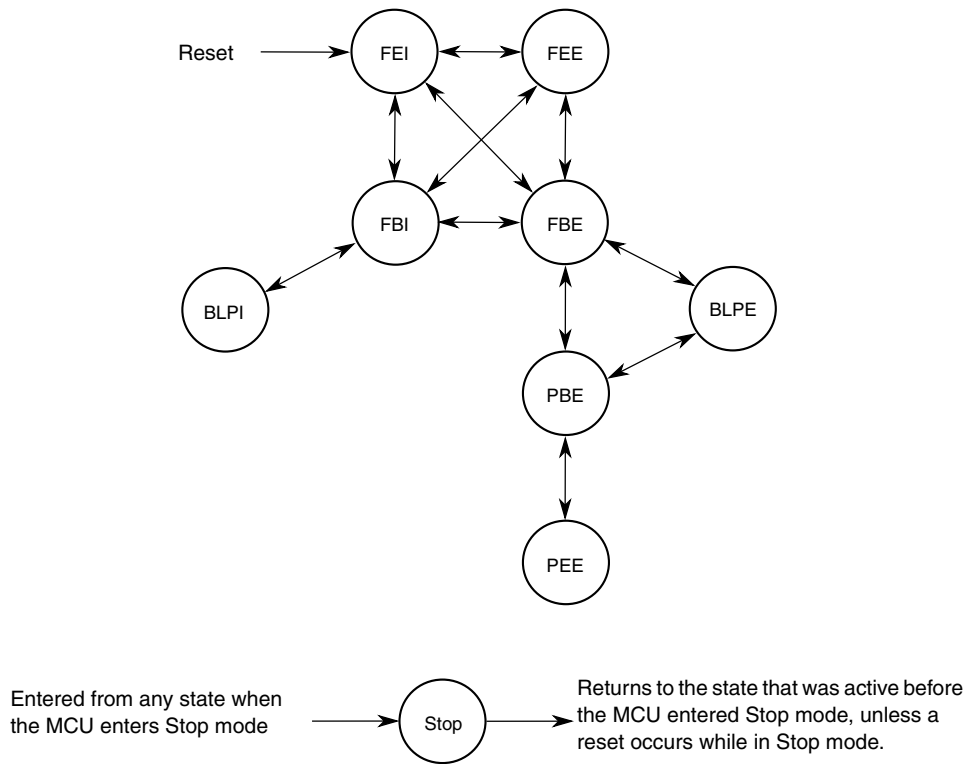

Figure 24-12. MCG Mode State Diagram

NOTE

- During exits from LLS or VLPS when the MCG is in PEE mode, the MCG will reset to PBE clock mode and the C1[CLKS] and S[CLKST] will automatically be set to 2'b10.
- If entering Normal Stop mode when the MCG is in PEE mode with C5[PLLSTEN]=0, the MCG will reset to PBE clock mode and C1[CLKS] and S[CLKST] will automatically be set to 2'b10.

24.4.1.1 MCG Modes of Operation

The MCG operates in one of the following modes.

Note

The MCG restricts transitions between modes. For the permitted transitions, see [Figure 24-12](#).

Table 24-14. MCG Modes of Operation

Mode	Description
FLL Engaged Internal (FEI)	<p>FLL engaged internal (FEI) is the default mode of operation and is entered when all the following conditions occur:</p> <ul style="list-style-type: none"> • C1[CLKS] bits are written to 00 • C1[IREFS] bit is written to 1 • C6[PLLS] bit is written to 0 <p>In FEI mode, MCGOUTCLK is derived from the FLL clock (DCOCLK) that is controlled by the 32 kHz Internal Reference Clock (IRC). The FLL loop will lock the DCO frequency to the FLL factor, as selected by the C4[DRST_DRS] and C4[DMX32] bits, times the internal reference frequency. Refer to the C4[DMX32] bit description for more details. In FEI mode, the PLL is disabled in a low-power state unless C5[PLLCLKEN] is set.</p>
FLL Engaged External (FEE)	<p>FLL engaged external (FEE) mode is entered when all the following conditions occur:</p> <ul style="list-style-type: none"> • C1[CLKS] bits are written to 00 • C1[IREFS] bit is written to 0 • C1[FRDIV] must be written to divide external reference clock to be within the range of 31.25 kHz to 39.0625 kHz • C6[PLLS] bit is written to 0 <p>In FEE mode, MCGOUTCLK is derived from the FLL clock (DCOCLK) that is controlled by the external reference clock. The FLL loop will lock the DCO frequency to the FLL factor, as selected by C4[DRST_DRS] and C4[DMX32] bits, times the external reference frequency, as specified by the C1[FRDIV] and C2[RANGE]. Refer to the C4[DMX32] bit description for more details. In FEE mode, the PLL is disabled in a low-power state unless C5[PLLCLKEN] is set.</p>
FLL Bypassed Internal (FBI)	<p>FLL bypassed internal (FBI) mode is entered when all the following conditions occur:</p> <ul style="list-style-type: none"> • C1[CLKS] bits are written to 01 • C1[IREFS] bit is written to 1 • C6[PLLS] is written to 0 • C2[LP] is written to 0 <p>In FBI mode, the MCGOUTCLK is derived either from the slow (32 kHz IRC) or fast (2 MHz IRC) internal reference clock, as selected by the C2[IRCS] bit. The FLL is operational but its output is not used. This mode is useful to allow the FLL to acquire its target frequency while the MCGOUTCLK is driven from the C2[IRCS] selected internal reference clock. The FLL clock (DCOCLK) is controlled by the slow internal reference clock, and the DCO clock frequency locks to a multiplication factor, as selected by the C4[DRST_DRS] and C4[DMX32] bits, times the internal reference frequency. Refer to the C4[DMX32] bit description for more details. In FBI mode, the PLL is disabled in a low-power state unless C5[PLLCLKEN] is set.</p>

Table continues on the next page...

Table 24-14. MCG Modes of Operation (continued)

Mode	Description
FLL Bypassed External (FBE)	<p>FLL bypassed external (FBE) mode is entered when all the following conditions occur:</p> <ul style="list-style-type: none"> • C1[CLKS] bits are written to 10 • C1[IREFS] bit is written to 0 • C1[FRDIV] must be written to divide external reference clock to be within the range of 31.25 kHz to 39.0625 kHz. • C6[PLLS] bit is written to 0 • C2[LP] is written to 0 <p>In FBE mode, the MCGOUTCLK is derived from the OSCSEL external reference clock. The FLL is operational but its output is not used. This mode is useful to allow the FLL to acquire its target frequency while the MCGOUTCLK is driven from the external reference clock. The FLL clock (DCOCLK) is controlled by the external reference clock, and the DCO clock frequency locks to a multiplication factor, as selected by the C4[DRST_DRS] and C4[DMX32] bits, times the divided external reference frequency. Refer to the C4[DMX32] bit description for more details. In FBI mode the PLL is disabled in a low-power state unless C5[PLLCLKEN] is set.</p>
PLL Engaged External (PEE)	<p>PLL Engaged External (PEE) mode is entered when all the following conditions occur:</p> <ul style="list-style-type: none"> • C1[CLKS] bits are written to 00 • C1[IREFS] bit is written to 0 • C6[PLLS] bit is written to 1 <p>In PEE mode, the MCGOUTCLK is derived from the PLL clock, which is controlled by the external reference clock. The PLL clock frequency locks to a multiplication factor, as specified by C6[VDIV], times the external reference frequency, as specified by C5[PRDIV]. The PLL's programmable reference divider must be configured to produce a valid PLL reference clock. The FLL is disabled in a low-power state.</p>
PLL Bypassed External (PBE)	<p>PLL Bypassed External (PBE) mode is entered when all the following conditions occur:</p> <ul style="list-style-type: none"> • C1[CLKS] bits are written to 10 • C1[IREFS] bit is written to 0 • C6[PLLS] bit is written to 1 • C2[LP] bit is written to 0 <p>In PBE mode, MCGOUTCLK is derived from the OSCSEL external reference clock; the PLL is operational, but its output clock is not used. This mode is useful to allow the PLL to acquire its target frequency while MCGOUTCLK is driven from the external reference clock. The PLL clock frequency locks to a multiplication factor, as specified by its [VDIV], times the PLL reference frequency, as specified by its [PRDIV]. In preparation for transition to PEE, the PLL's programmable reference divider must be configured to produce a valid PLL reference clock. The FLL is disabled in a low-power state.</p>

Table continues on the next page...

Table 24-14. MCG Modes of Operation (continued)

Mode	Description
Bypassed Low Power Internal (BLPI) ¹	<p>Bypassed Low Power Internal (BLPI) mode is entered when all the following conditions occur:</p> <ul style="list-style-type: none"> • C1[CLKS] bits are written to 01 • C1[IREFS] bit is written to 1 • C6[PLLS] bit is written to 0 • C2[LP] bit is written to 1 <p>In BLPI mode, MCGOUTCLK is derived from the internal reference clock. The FLL is disabled and PLL is disabled even if the C5[PLLCLKEN] is set to 1.</p>
Bypassed Low Power External (BLPE)	<p>Bypassed Low Power External (BLPE) mode is entered when all the following conditions occur:</p> <ul style="list-style-type: none"> • C1[CLKS] bits are written to 10 • C1[IREFS] bit is written to 0 • C2[LP] bit is written to 1 <p>In BLPE mode, MCGOUTCLK is derived from the OSCSEL external reference clock. The FLL is disabled and PLL is disabled even if the C5[PLLCLKEN] is set to 1.</p>
Stop	<p>Entered whenever the MCU enters a Stop state. The power modes are chip specific. For power mode assignments, see the chapter that describes how modules are configured and MCG behavior during Stop recovery. Entering Stop mode, the FLL is disabled, and all MCG clock signals are static except in the following case:</p> <p>MCGPLLCLK is active in Normal Stop mode when PLLSTEN=1</p> <p>MCGIRCLK is active in Stop mode when all the following conditions become true:</p> <ul style="list-style-type: none"> • C1[IRCLKEN] = 1 • C1[IREFSTEN] = 1 <p>NOTE:</p> <ul style="list-style-type: none"> • When entering Low Power Stop modes (LLS or VLPS) from PEE mode, on exit the MCG clock mode is forced to PBE clock mode, the C1[CLKS] and S[CLKST] will be configured to 2'b10 and S[LOCK] bit will be cleared without setting S[LOLS]. • When entering Normal Stop mode from PEE mode and if C5[PLLSTEN]=0, on exit the MCG clock mode is forced to PBE mode, the C1[CLKS] and S[CLKST] will be configured to 2'b10 and S[LOCK] bit will clear without setting S[LOLS]. If C5[PLLSTEN]=1, the S[LOCK] bit will not get cleared and on exit the MCG will continue to run in PEE mode.

1. If entering VLPR mode, MCG has to be configured and enter BLPE mode or BLPI mode with the 4 MHz IRC clock selected (C2[IRCS]=1). Once in VLPR mode, writes to any of the MCG control registers that can cause a MCG clock mode switch to a non low power clock mode must be avoided.

NOTE

For the chip-specific modes of operation, refer to the power management chapter of this MCU.

24.4.1.2 MCG Mode Switching

The C1[IREFS] bit can be changed at any time, but the actual switch to the newly selected reference clocks is shown by the S[IREFST] bit. When switching between engaged internal and engaged external modes, the FLL will begin locking again after the switch is completed.

The C1[CLKS] bits can also be changed at anytime, but the actual switch to the newly selected clock is shown by the S[CLKST] bits. If the newly selected clock is not available, the previous clock will remain selected.

The C4[DRST_DRS] write bits can be changed at anytime except when C2[LP] bit is 1. If the C4[DRST_DRS] write bits are changed while in FLL engaged internal (FEI) or FLL engaged external (FEE), the MCGOUTCLK will switch to the new selected DCO range within three clocks of the selected DCO clock. After switching to the new DCO, the FLL remains unlocked for several reference cycles. DCO startup time is equal to the FLL acquisition time. After the selected DCO startup time is over, the FLL is locked. The completion of the switch is shown by the C4[DRST_DRS] read bits.

24.4.2 Low Power Bit Usage

The C2[LP] bit is provided to allow the FLL or PLL to be disabled and thus conserve power when these systems are not being used. The C4[DRST_DRS] can not be written while C2[LP] bit is 1. However, in some applications, it may be desirable to enable the FLL or PLL and allow it to lock for maximum accuracy before switching to an engaged mode. Do this by writing C2[LP] to 0.

24.4.3 MCG Internal Reference Clocks

This module supports two internal reference clocks with nominal frequencies of 32 kHz (slow IRC) and 4 MHz (fast IRC).

24.4.3.1 MCG Internal Reference Clock

The MCG Internal Reference Clock (MCGIRCLK) provides a clock source for other on-chip peripherals and is enabled when C1[IRCLKEN]=1. When enabled, MCGIRCLK is driven by either the fast internal reference clock (2 MHz IRC) or the slow internal reference clock (32 kHz IRC). The IRCS clock frequency can be re-targeted by trimming the period of its IRCS selected internal reference clock. This can be done by writing a new trim value to the C3[SCTRIM]:C4[SCFTRIM] bits when the slow IRC clock is

selected or by writing a new trim value to the C4[FCTRIM] bits when the fast IRC clock is selected. The internal reference clock period is proportional to the trim value written. C3[SCTRIM]:C4[SCFTRIM] (if C2[IRCS]=0) and C4[FCTRIM] (if C2[IRCS]=1) bits affect the MCGOUTCLK frequency if the MCG is in FBI or BLPI modes. C3[SCTRIM]:C4[SCFTRIM] (if C2[IRCS]=0) bits also affect the MCGOUTCLK frequency if the MCG is in FEI mode.

Additionally, this clock can be enabled in Stop mode by setting C1[IRCLKEN] and C1[IREFSTEN], otherwise this clock is disabled in Stop mode.

24.4.4 External Reference Clock

The MCG module can support an external reference clock in all modes. Refer to the device datasheet for external reference frequency range. When C1[IREFS] is set, the external reference clock will not be used by the FLL or PLL. In these modes, the frequency can be equal to the maximum frequency the chip-level timing specifications will support.

If the CME is asserted the slow internal reference clock is enabled along with the enabled external clock monitor. For the case when C6[CME]=1, a loss of clock is detected if the OSC external reference falls below a minimum frequency (f_{loc_high} or f_{loc_low} depending on C2[RANGE]).

Upon detect of a loss of clock event, the MCU generates a system reset if the respective LOCRE bit is set. Otherwise the MCG sets the respective LOCS bit and the MCG generates a LOCS interrupt request.

24.4.5 MCG Fixed Frequency Clock

The MCG Fixed Frequency Clock (MCGFFCLK) provides a fixed frequency clock source for other on-chip peripherals. This clock is driven by either the slow clock from the internal reference clock generator or the external reference clock from the Crystal Oscillator, divided by the FLL reference clock divider. The source of MCGFFCLK is selected by C1[IREFS]. Additionally, this clock is divided by two.

This clock is synchronized to the peripheral bus clock and is only valid when its frequency is not more than 1/8 of the MCGOUTCLK frequency. When it is not valid, it is disabled and held high. The MCGFFCLK is not available when the MCG is in BLPI mode. This clock is also disabled in Stop mode. The FLL reference clock must be set within the valid frequency range for the MCGFFCLK.

24.4.6 MCG PLL Clock

The MCG PLL Clock (MCGPLLCLK) is available depending on the device's configuration of the MCG module. For more details, refer to the clock distribution chapter of this MCU. The MCGPLLCLK is prevented from coming out of the MCG until it is enabled and S[LOCK] is set.

24.4.7 MCG Auto TRIM (ATM)

The MCG Auto Trim (ATM) is a MCG feature that when enabled, it configures the MCG hardware to automatically trim the MCG Internal Reference Clocks using an external clock as a reference. The selection between which MCG IRC clock gets tested and enabled is controlled by the ATC[ATMS] control bit (ATC[ATMS]=0 selects the 32 kHz IRC and ATC[ATMS]=1 selects the 4 MHz IRC). If 4 MHz IRC is selected for the ATM, a divide by 128 is enabled to divide down the 4 MHz IRC to a range of 31.250 kHz.

When MCG ATM is enabled by writing ATC[ATME] bit to 1, The ATM machine will start auto trimming the selected IRC clock. During the autotrim process, ATC[ATME] will remain asserted and will deassert after ATM is completed or an abort occurs. The MCG ATM is aborted if a write to any of the following control registers is detected including: C1, C3, C4, or ATC or if Stop mode is entered. If an abort occurs, ATC[ATMF] fail flag is asserted.

The ATM machine uses the bus clock as the external reference clock to perform the IRC auto-trim. Therefore, it is required that the MCG is configured in a clock mode where the reference clock used to generate the system clock is the external reference clock such as FBE clock mode. The MCG must not be configured in a clock mode where selected IRC ATM clock is used to generate the system clock. The bus clock is also required to be running with in the range of 8 - 16 MHz.

To perform the ATM on the selected IRC, the ATM machine uses the successive approximation technique to adjust the IRC trim bits to generate the desired IRC trimmed frequency. The ATM SARs each of the ATM IRC trim bits starting with the MSB. For each trim bit test, the ATM uses a pulse that is generated by the ATM selected IRC clock to enable a counter that counts number of ATM external clocks. At end of each trim bit, the ATM external counter value is compared to the ATCV[15:0] register value. Based on the comparison result, the ATM trim bit under test will get cleared or stay asserted. This is done until all trim bits have been tested by ATM SAR machine.

Before the ATM can be enabled, the ATM expected count needs to get derived and stored into the ATCV register. The ATCV expected count is derived based on the required target Internal Reference Clock (IRC) frequency, the frequency of the external reference clock, and using the following formula:

$$\text{ATCV Expected Count Value} = 21 * (\text{Fe} / \text{Fr})$$

- Fr = Target Internal Reference Clock (IRC) Trimmed Frequency
- Fe = External Clock Frequency

If the auto trim is being performed on the 4 MHz IRC, the calculated expected count value must be multiplied by 128 before storing it in the ATCV register. Therefore, the ATCV Expected Count Value for trimming the 4 MHz IRC is calculated using the following formula.

$$\text{Expected Count Value} = (\text{Fe} / \text{Fr}) * 21 * (128)$$

24.5 Initialization / Application Information

This section describes how to initialize and configure the MCG module in an application. The following sections include examples on how to initialize the MCG and properly switch between the various available modes.

24.5.1 MCG Module Initialization Sequence

The MCG comes out of reset configured for FEI mode. The internal reference will stabilize in t_{refsts} microseconds before the FLL can acquire lock. As soon as the internal reference is stable, the FLL will acquire lock in $t_{\text{fll_acquire}}$ milliseconds.

24.5.1.1 Initializing the MCG

Because the MCG comes out of reset in FEI mode, the only MCG modes that can be directly switched to upon reset are FEE, FBE, and FBI modes (see [Figure 24-12](#)). Reaching any of the other modes requires first configuring the MCG for one of these three intermediate modes. Care must be taken to check relevant status bits in the MCG status register reflecting all configuration changes within each mode.

To change from FEI mode to FEE or FBE modes, follow this procedure:

1. Enable the external clock source by setting the appropriate bits in C2 register.

2. Write to C1 register to select the clock mode.
 - If entering FEE mode, set C1[FRDIV] appropriately, clear the C1[IREFS] bit to switch to the external reference, and leave the C1[CLKS] bits at 2'b00 so that the output of the FLL is selected as the system clock source.
 - If entering FBE, clear the C1[IREFS] bit to switch to the external reference and change the C1[CLKS] bits to 2'b10 so that the external reference clock is selected as the system clock source. The C1[FRDIV] bits should also be set appropriately here according to the external reference frequency to keep the FLL reference clock in the range of 31.25 kHz to 39.0625 kHz. Although the FLL is bypassed, it is still on in FBE mode.
 - The internal reference can optionally be kept running by setting the C1[IRCLKEN] bit. This is useful if the application will switch back and forth between internal and external modes. For minimum power consumption, leave the internal reference disabled while in an external clock mode.
3. Once the proper configuration bits have been set, wait for the affected bits in the MCG status register to be changed appropriately, reflecting that the MCG has moved into the proper mode.
 - If the MCG is in FEE, FBE, PEE, PBE, or BLPE mode, and C2[EREFS] was also set in step 1, wait here for S[OSCINIT] bit to become set indicating that the external clock source has finished its initialization cycles and stabilized.
 - If in FEE mode, check to make sure the S[IREFST] bit is cleared before moving on.
 - If in FBE mode, check to make sure the S[IREFST] bit is cleared and S[CLKST] bits have changed to 2'b10 indicating the external reference clock has been appropriately selected. Although the FLL is bypassed, it is still on in FBE mode.
4. Write to the C4 register to determine the DCO output (MCGFLLCLK) frequency range.
 - By default, with C4[DMX32] cleared to 0, the FLL multiplier for the DCO output is 640. For greater flexibility, if a mid-low-range FLL multiplier of 1280 is desired instead, set C4[DRST_DRS] bits to 2'b01 for a DCO output frequency of 40 MHz. If a mid high-range FLL multiplier of 1920 is desired instead, set the C4[DRST_DRS] bits to 2'b10 for a DCO output frequency of 60 MHz. If a high-range FLL multiplier of 2560 is desired instead, set the C4[DRST_DRS] bits to 2'b11 for a DCO output frequency of 80 MHz.

- When using a 32.768 kHz external reference, if the maximum low-range DCO frequency that can be achieved with a 32.768 kHz reference is desired, set C4[DRST_DRS] bits to 2'b00 and set C4[DMX32] bit to 1. The resulting DCO output (MCGOUTCLK) frequency with the new multiplier of 732 will be 24 MHz.
 - When using a 32.768 kHz external reference, if the maximum mid-range DCO frequency that can be achieved with a 32.768 kHz reference is desired, set C4[DRST_DRS] bits to 2'b01 and set C4[DMX32] bit to 1. The resulting DCO output (MCGOUTCLK) frequency with the new multiplier of 1464 will be 48 MHz.
 - When using a 32.768 kHz external reference, if the maximum mid high-range DCO frequency that can be achieved with a 32.768 kHz reference is desired, set C4[DRST_DRS] bits to 2'b10 and set C4[DMX32] bit to 1. The resulting DCO output (MCGOUTCLK) frequency with the new multiplier of 2197 will be 72 MHz.
 - When using a 32.768 kHz external reference, if the maximum high-range DCO frequency that can be achieved with a 32.768 kHz reference is desired, set C4[DRST_DRS] bits to 2'b11 and set C4[DMX32] bit to 1. The resulting DCO output (MCGOUTCLK) frequency with the new multiplier of 2929 will be 96 MHz.
5. Wait for the FLL lock time to guarantee FLL is running at new C4[DRST_DRS] and C4[DMX32] programmed frequency.

To change from FEI clock mode to FBI clock mode, follow this procedure:

1. Change C1[CLKS] bits in C1 register to 2'b01 so that the internal reference clock is selected as the system clock source.
2. Wait for S[CLKST] bits in the MCG status register to change to 2'b01, indicating that the internal reference clock has been appropriately selected.
3. Write to the C2 register to determine the IRCS output (IRCSCLK) frequency range.
 - By default, with C2[IRCS] cleared to 0, the IRCS selected output clock is the slow internal reference clock (32 kHz IRC). If the faster IRC is desired, set C2[IRCS] bit to 1 for a IRCS clock derived from the 4 MHz IRC source.

24.5.2 Using a 32.768 kHz Reference

In FEE and FBE modes, if using a 32.768 kHz external reference, at the default FLL multiplication factor of 640, the DCO output (MCGFLLCLK) frequency is 20.97 MHz at low-range. If C4[DRST_DRS] bits are set to 2'b01, the multiplication factor is doubled to 1280, and the resulting DCO output frequency is 41.94 MHz at mid-low-range. If C4[DRST_DRS] bits are set to 2'b10, the multiplication factor is set to 1920, and the resulting DCO output frequency is 62.91 MHz at mid high-range. If C4[DRST_DRS] bits are set to 2'b11, the multiplication factor is set to 2560, and the resulting DCO output frequency is 83.89 MHz at high-range.

In FBI and FEI modes, setting C4[DMX32] bit is not recommended. If the internal reference is trimmed to a frequency above 32.768 kHz, the greater FLL multiplication factor could potentially push the microcontroller system clock out of specification and damage the part.

The RTC 32 kHz oscillator may be used as the FLL reference clock. Refer to the SIM chapter on how this can be selected. The MCG must be in an internal clocking mode (FEI, FBI or BLPI) when the external clock selection mux is switched. The C2[RANGE] bits must be set to 2'b00 and the C1[FRDIV] bits must be set to 3'b000 to ensure this clock is divided by 1 to keep it within the allowed FLL reference clock range.

24.5.3 MCG Mode Switching

When switching between operational modes of the MCG, certain configuration bits must be changed in order to properly move from one mode to another. Each time any of these bits are changed (C6[PLLS], C1[IREFS], C1[CLKS], C2[IRCS], or C2[EREFS]), the corresponding bits in the MCG status register (PLLST, IREFST, CLKST, IRCST, or OSCINIT) must be checked before moving on in the application software.

Additionally, care must be taken to ensure that the reference clock divider (C1[FRDIV] and C5[PRDIV]) is set properly for the mode being switched to. For instance, in PEE mode, if using a 4 MHz crystal, C5[PRDIV] must be set to 5'b000 (divide-by-1) or 5'b001 (divide -by-2) in order to divide the external reference down to the required frequency between 2 and 4 MHz.

In FBE, FEE, FBI, and FEI modes, at any time, the application can switch the FLL multiplication factor between 640, 1280, 1920, and 2560 with C4[DRST_DRS] bits. Writes to C4[DRST_DRS] bits will be ignored if C2[LP]=1.

The table below shows MCGOUTCLK frequency calculations using C1[FRDIV], C5[PRDIV], and C6[VDIV] settings for each clock mode.

Table 24-15. MCGOUTCLK Frequency Calculation Options

Clock Mode	$f_{MCGOUTCLK}^1$	Note
FEI (FLL engaged internal)	$(f_{int} * F)$	Typical $f_{MCGOUTCLK} = 20$ MHz immediately after reset.
FEE (FLL engaged external)	$(f_{ext} / FLL_R) * F$	f_{ext} / FLL_R must be in the range of 31.25 kHz to 39.0625 kHz
FBE (FLL bypassed external)	f_{ext}	f_{ext} / FLL_R must be in the range of 31.25 kHz to 39.0625 kHz
FBI (FLL bypassed internal)	f_{int}	Typical $f_{int} = 32$ kHz
PEE (PLL engaged external)	$(f_{ext} / PLL_R) * M$	f_{ext} / PLL_R must be in the range of 2 – 4 MHz
PBE (PLL bypassed external)	f_{ext}	f_{ext} / PLL_R must be in the range of 2 – 4 MHz
BLPI (Bypassed low power internal)	f_{int}	
BLPE (Bypassed low power external)	f_{ext}	

1. FLL_R is the reference divider selected by the C1[FRDIV] bits, PLL_R is the reference divider selected by C5[PRDIV] bits, F is the FLL factor selected by C4[DRST_DRS] and C4[DMX32] bits, and M is the multiplier selected by C6[VDIV] bits.

This section will include 3 mode switching examples using an 4 MHz external crystal. If using an external clock source less than 2 MHz, the MCG should not be configured for any of the PLL modes (PEE and PBE).

24.5.3.1 Example 1: Moving from FEI to PEE Mode : External Crystal = 4 MHz, MCGOUTCLK Frequency = 48 MHz

In this example, the MCG will move through the proper operational modes from FEI to PEE to achieve 48 MHz MCGOUTCLK frequency from 4 MHz external crystal reference. First, the code sequence will be described. Then a flowchart will be included which illustrates the sequence.

1. First, FEI must transition to FBE mode:
 - a. C2 = 0x1C
 - C2[RANGE] set to 2'b01 because the frequency of 4 MHz is within the high frequency range
 - C2[HGO] set to 1 to configure the crystal oscillator for high gain operation
 - C2[EREFS] set to 1, because a crystal is being used
 - b. C1 = 0x90

- C1[CLKS] set to 2'b10 in order to select external reference clock as system clock source
 - C1[FRDIV] set to 3'b010, or divide-by-128 because $4 \text{ MHz} / 128 = 31.25 \text{ kHz}$ which is in the 31.25 kHz to 39.0625 kHz range required by the FLL
 - C1[IREFS] cleared to 0, selecting the external reference clock and enabling the external oscillator.
- c. Loop until S[OSCINIT] is 1, indicating the crystal selected by C2[EREFS] has been initialized..
 - d. Loop until S[IREFST] is 0, indicating the external reference is the current source for the reference clock
 - e. Loop until S[CLKST] is 2'b10, indicating that the external reference clock is selected to feed MCGOUTCLK
2. Then configure C5[PRDIV] to generate correct PLL reference frequency.
 - a. C5 = 0x01
 - C5[PRDIV] set to 5'b001, or divide-by-2 resulting in a pll reference frequency of $4 \text{ MHz} / 2 = 2 \text{ MHz}$.
 3. Then, FBE must transition either directly to PBE mode or first through BLPE mode and then to PBE mode:
 - a. BLPE: If a transition through BLPE mode is desired, first set C2[LP] to 1.
 - b. BLPE/PBE: C6 = 0x40
 - C6[PLLS] set to 1, selects the PLL. At this time, with a C1[PRDIV] value of 2'b001, the PLL reference divider is 2 (see PLL External Reference Divide Factor table), resulting in a reference frequency of $4 \text{ MHz} / 2 = 2 \text{ MHz}$. In BLPE mode, changing the C6[PLLS] bit only prepares the MCG for PLL usage in PBE mode.
 - C6[VDIV] set to 5'b0000, or multiply-by-24 because $2 \text{ MHz reference} * 24 = 48 \text{ MHz}$. In BLPE mode, the configuration of the VDIV bits does not matter because the PLL is disabled. Changing them only sets up the multiply value for PLL usage in PBE mode.
 - c. BLPE: If transitioning through BLPE mode, clear C2[LP] to 0 here to switch to PBE mode.
 - d. PBE: Loop until S[PLLST] is set, indicating that the current source for the PLLS clock is the PLL.

- e. PBE: Then loop until S[LOCK] is set, indicating that the PLL has acquired lock.
4. Lastly, PBE mode transitions into PEE mode:
- a. C1 = 0x10
 - C1[CLKS] set to 2'b00 in order to select the output of the PLL as the system clock source.
 - b. Loop until S[CLKST] are 2'b11, indicating that the PLL output is selected to feed MCGOUTCLK in the current clock mode.
 - Now, With PRDIV of divide-by-2, and C6[VDIV] of multiply-by-24, $MCGOUTCLK = [(4 \text{ MHz} / 2) * 24] = 48 \text{ MHz}$.

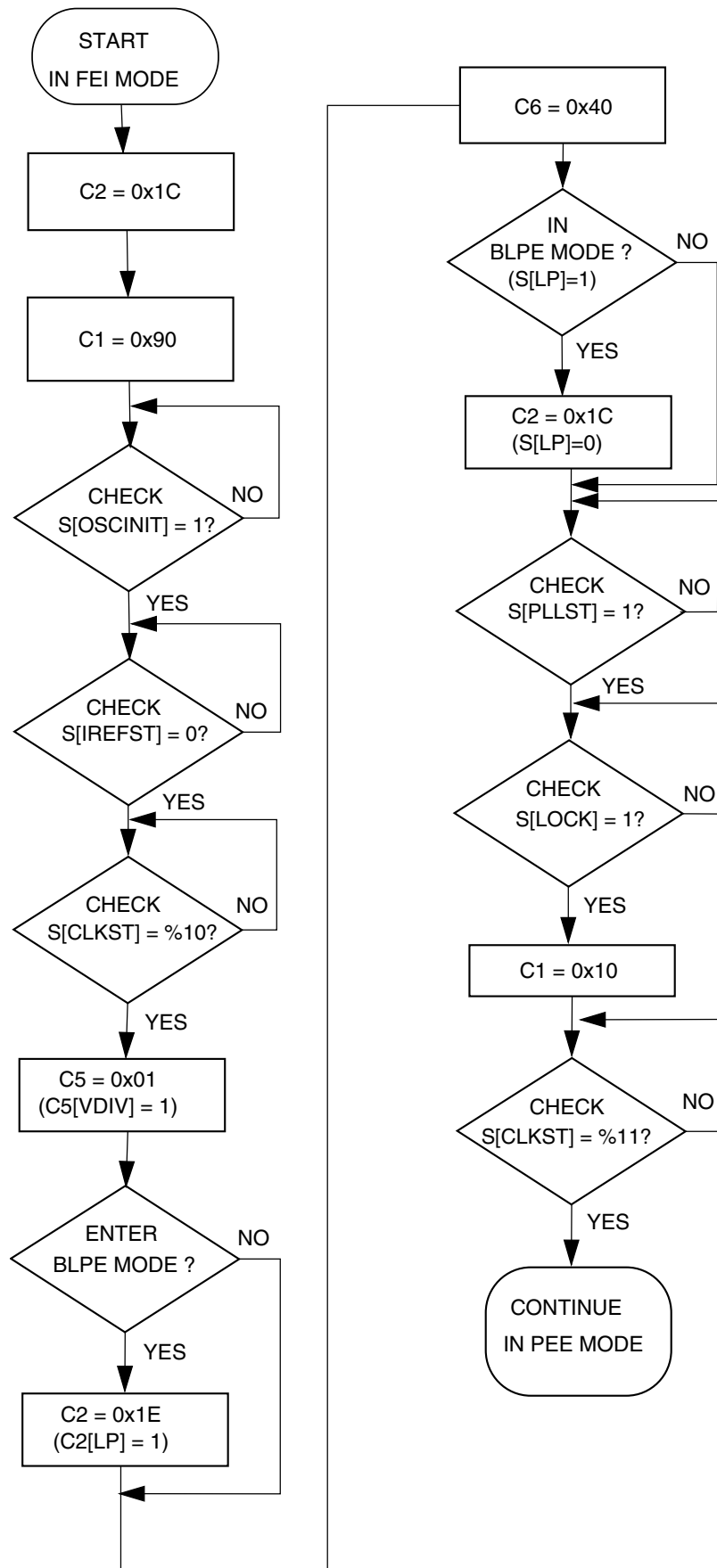

Figure 24-13. Flowchart of FEI to PEE Mode Transition using a 4 MHz crystal
K40 Sub-Family Reference Manual, Rev. 6, Nov 2011

24.5.3.2 Example 2: Moving from PEE to BLPI Mode: MCGOUTCLK Frequency =32 kHz

In this example, the MCG will move through the proper operational modes from PEE mode with a 4 MHz crystal configured for a 48 MHz MCGOUTCLK frequency (see previous example) to BLPI mode with a 32 kHz MCGOUTCLK frequency. First, the code sequence will be described. Then a flowchart will be included which illustrates the sequence.

1. First, PEE must transition to PBE mode:
 - a. C1 = 0x90
 - C1[CLKS] set to 2'b10 in order to switch the system clock source to the external reference clock.
 - b. Loop until S[CLKST] are 2'b10, indicating that the external reference clock is selected to feed MCGOUTCLK.
2. Then, PBE must transition either directly to FBE mode or first through BLPE mode and then to FBE mode:
 - a. BLPE: If a transition through BLPE mode is desired, first set C2[LP] to 1
 - b. BLPE/FBE: C6 = 0x00
 - C6[PLLS] clear to 0 to select the FLL. At this time, with C1[FRDIV] value of 3'b010, the FLL divider is set to 128, resulting in a reference frequency of $4 \text{ MHz} / 128 = 31.25 \text{ kHz}$. If C1[FRDIV] was not previously set to 3'b010 (necessary to achieve required 31.25-39.06 kHz FLL reference frequency with an 4 MHz external source frequency), it must be changed prior to clearing C6[PLLS] bit. In BLPE mode, changing this bit only prepares the MCG for FLL usage in FBE mode. With C6[PLLS] = 0, the C6[VDIV] value does not matter.
 - c. BLPE: If transitioning through BLPE mode, clear C2[LP] to 0 here to switch to FBE mode.
 - d. FBE: Loop until S[PLLST] is cleared, indicating that the current source for the PLLS clock is the FLL.
3. Next, FBE mode transitions into FBI mode:
 - a. C1 = 0x54

- C1[CLKS] set to 2'b01 in order to switch the system clock to the internal reference clock.
 - C1[IREFS] set to 1 to select the internal reference clock as the reference clock source.
 - C1[FRDIV] remain unchanged because the reference divider does not affect the internal reference.
- b. Loop until S[IREFST] is 1, indicating the internal reference clock has been selected as the reference clock source.
- c. Loop until S[CLKST] are 2'b01, indicating that the internal reference clock is selected to feed MCGOUTCLK.
4. Lastly, FBI transitions into BLPI mode.
- a. C2 = 0x02
- C2[LP] is 1
 - C2[RANGE], C2[HGO], C2[EREFS], C1[IRCLKEN], and C1[IREFSTEN] bits are ignored when the C1[IREFS] bit is set. They can remain set, or be cleared at this point.

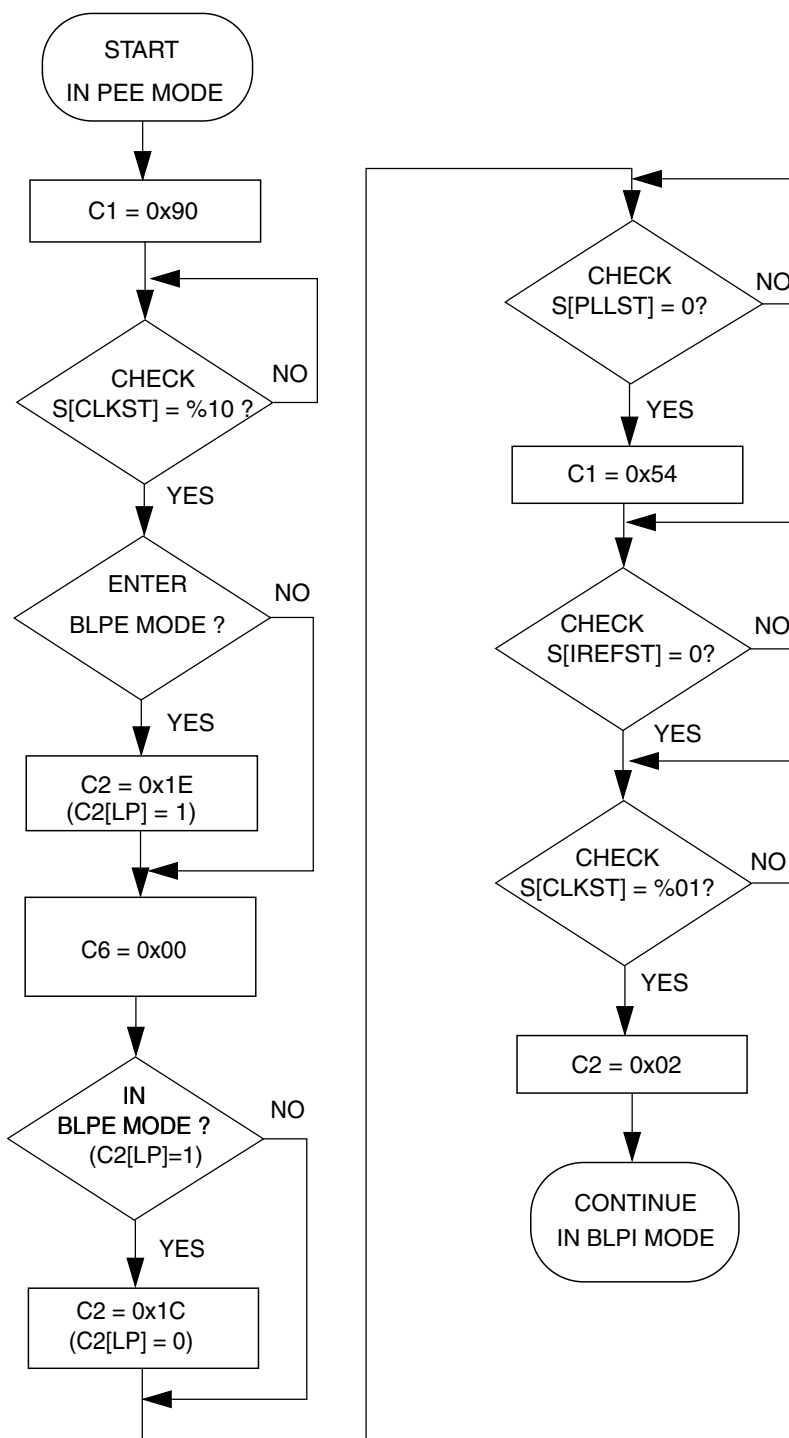

Figure 24-14. Flowchart of PEE to BLPI Mode Transition using an 4 MHz crystal

24.5.3.3 Example 3: Moving from BLPI to FEE Mode

In this example, the MCG will move through the proper operational modes from BLPI mode at a 32 kHz MCGOUTCLK frequency running off the internal reference clock (see previous example) to FEE mode using a 4 MHz crystal configured for a 20 MHz MCGOUTCLK frequency. First, the code sequence will be described. Then a flowchart will be included which illustrates the sequence.

1. First, BLPI must transition to FBI mode.
 - a. $C2 = 0x00$
 - $C2[LP]$ is 0
2. Next, FBI will transition to FEE mode.
 - a. $C2 = 0x1C$
 - $C2[RANGE]$ set to 2'b01 because the frequency of 4 MHz is within the high frequency range.
 - $C2[HGO]$ set to 1 to configure the crystal oscillator for high gain operation.
 - $C2[EREFS]$ set to 1, because a crystal is being used.
 - b. $C1 = 0x10$
 - $C1[CLKS]$ set to 2'b00 in order to select the output of the FLL as system clock source.
 - $C1[FRDIV]$ remain at 3'b010, or divide-by-128 for a reference of $4 \text{ MHz} / 128 = 31.25 \text{ kHz}$.
 - $C1[IREFS]$ cleared to 0, selecting the external reference clock.
 - c. Loop until $S[OSCINIT]$ is 1, indicating the crystal selected by the $C2[EREFS]$ bit has been initialized.
 - d. Loop until $S[IREFST]$ is 0, indicating the external reference clock is the current source for the reference clock.
 - e. Loop until $S[CLKST]$ are 2'b00, indicating that the output of the FLL is selected to feed MCGOUTCLK.
 - f. Now, with a 31.25 kHz reference frequency, a fixed DCO multiplier of 640, $MCGOUTCLK = 31.25 \text{ kHz} * 640 / 1 = 20 \text{ MHz}$.
 - g. At this point, by default, the $C4[DRST_DRS]$ bits are set to 2'b00 and $C4[DMX32]$ is cleared to 0. If the MCGOUTCLK frequency of 40 MHz is desired instead, set the $C4[DRST_DRS]$ bits to 0x01 to switch the FLL

multiplication factor from 640 to 1280. To return the MCGOUTCLK frequency to 20 MHz, set C4[DRST_DRS] bits to 2'b00 again, and the FLL multiplication factor will switch back to 640.

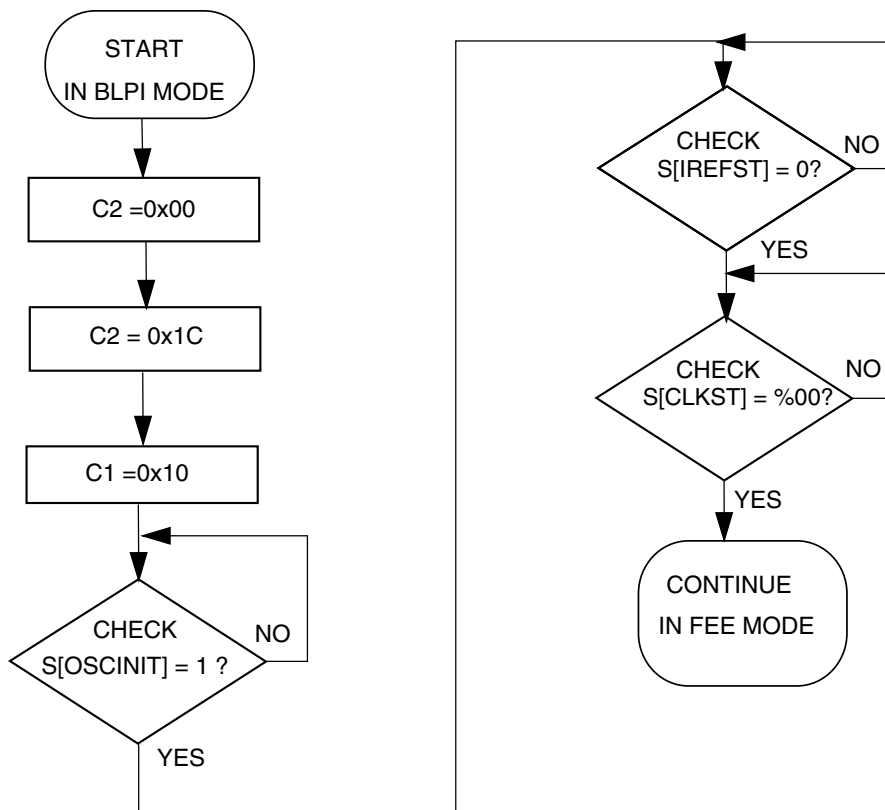

Figure 24-15. Flowchart of BLPI to FEE Mode Transition using an 4 MHz crystal

Chapter 25

Oscillator (OSC)

25.1 Introduction

NOTE

For the chip-specific implementation details of this module's instances see the chip configuration chapter.

The OSC module is a crystal oscillator. The module, in conjunction with an external crystal or resonator, generates a reference clock for the MCU.

25.2 Features and Modes

Key features of the module are:

- Supports 32 kHz crystals (Low Range mode)
- Supports 3–8 MHz, 8–32 MHz crystals and resonators (High Range mode)
- Automatic Gain Control (AGC) to optimize power consumption in high frequency ranges 3–8 MHz, 8–32 MHz using low-power mode
- High gain option in frequency ranges: 32 kHz, 3–8 MHz, and 8–32 MHz
- Voltage and frequency filtering to guarantee clock frequency and stability
- Optionally external input bypass clock from EXTAL signal directly
- One clock for MCU clock system
- Two clocks for on-chip peripherals that can work in Stop modes

[Functional Description](#) describes the module's operation in more detail.

25.3 Block Diagram

The OSC module uses a crystal or resonator to generate three filtered oscillator clock signals. Three clocks are output from OSC module: OSCCLK for MCU system, OSCERCLK for on-chip peripherals, and OSC32KCLK. The OSCCLK can only work in run mode. OSCERCLK and OSC32KCLK can work in low power modes. For the clock source assignments, refer to the clock distribution information of this MCU.

Refer to the chip configuration chapter for the external reference clock source in this MCU.

The following figure shows the block diagram of the OSC module.

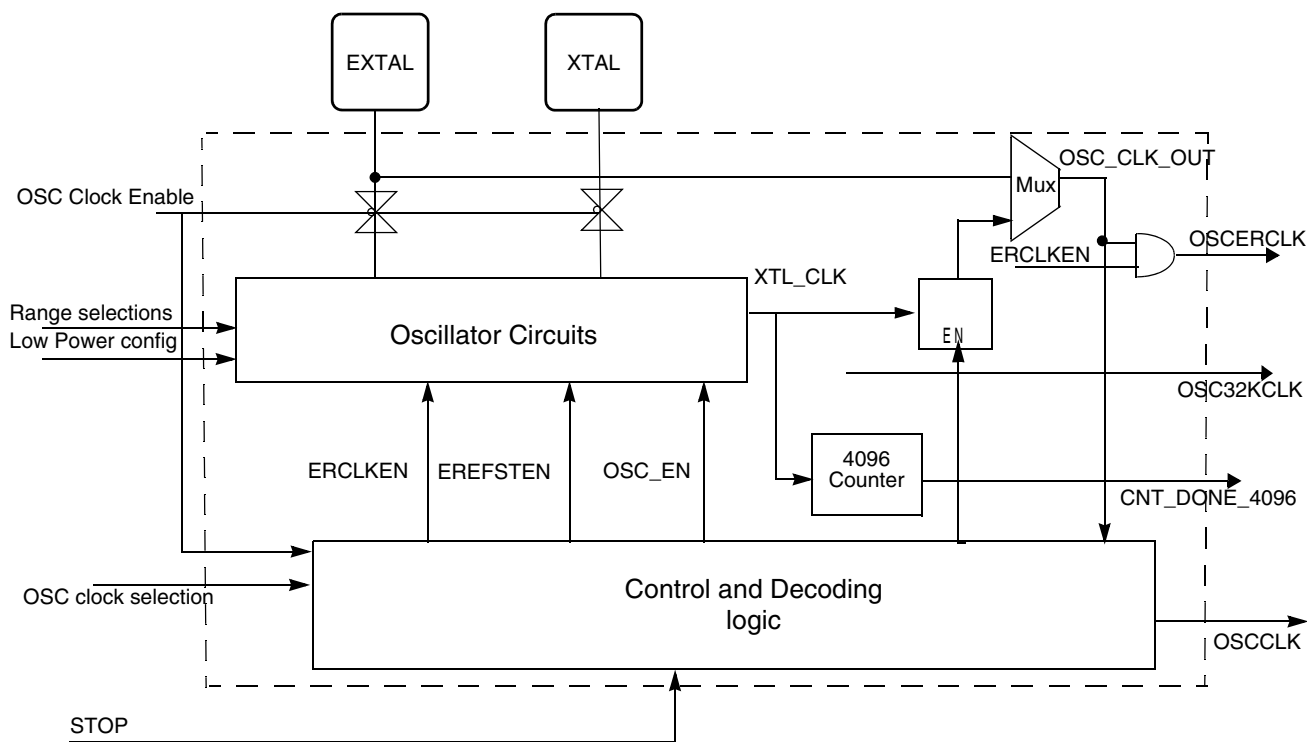

Figure 25-1. OSC Module Block Diagram

25.4 OSC Signal Descriptions

The following table shows the user-accessible signals available for the OSC module. Refer to signal multiplexing information for this MCU for more details.

Table 25-1. OSC Signal Descriptions

Signal	Description	I/O
EXTAL	External clock/Oscillator input	I
XTAL	Oscillator output	O

25.5 External Crystal / Resonator Connections

The connections for a crystal/resonator frequency reference are shown in the following figures. When using low-frequency, low-power mode, the only external component is the crystal or ceramic resonator itself. In the other oscillator modes, load capacitors (C_x , C_y) and feedback resistor (R_F) are required. The following table shows all possible connections.

Table 25-2. External Crystal/Resonator Connections

Oscillator Mode	Connections
Low-frequency (32 kHz), low-power	Connection 1
Low-frequency (32 kHz), high-gain	Connection 2/Connection 3 ¹
High-frequency (3~32 MHz), low-power	Connection 1/Connection 3 ^{2,2}
High-frequency (3~32 MHz), high-gain	Connection 2/Connection 3 ²

1. When the load capacitors (C_x , C_y) are greater than 30 pF, use Connection 3.
2. With the low-power mode, the oscillator has the internal feedback resistor R_F . Therefore, the feedback resistor must not be externally with the Connection 3.

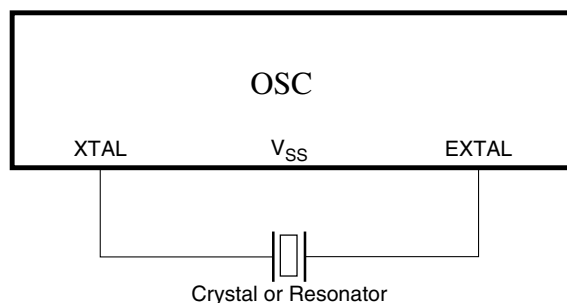
Figure 25-2. Crystal/Ceramic Resonator Connections - Connection 1

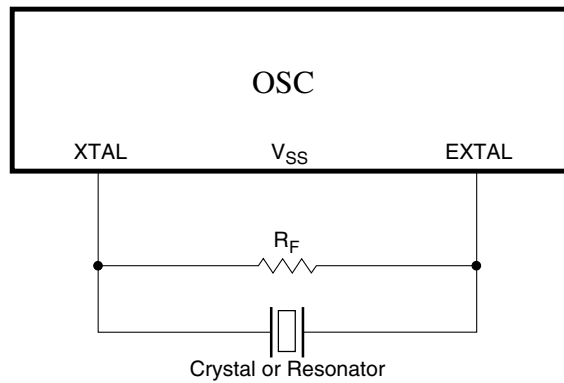

Figure 25-3. Crystal/Ceramic Resonator Connections - Connection 2

NOTE

Connection 1 and Connection 2 should use internal capacitors as the load of the oscillator by configuring the CR[SCxP] bits.

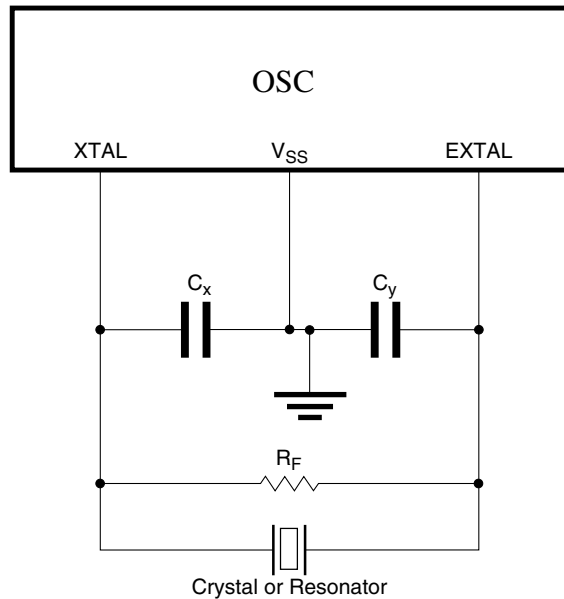

Figure 25-4. Crystal/Ceramic Resonator Connections - Connection 3

25.6 External Clock Connections

In external clock mode, the pins can be connected as shown below.

NOTE

XTAL can be used as a GPIO when the GPIO alternate function is configured for it.

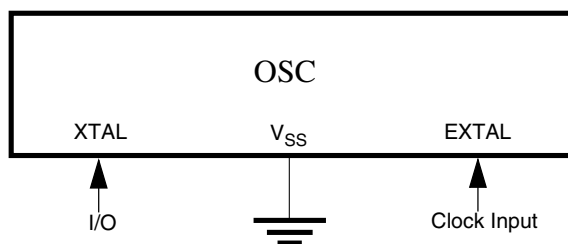

Figure 25-5. External Clock Connections

25.7 Memory Map/Register Definitions

Some oscillator module register bits are typically incorporated into other peripherals such as MCG or SIM.

25.7.1 OSC Memory Map/Register Definition

OSC memory map

Absolute address (hex)	Register name	Width (in bits)	Access	Reset value	Section/page
4006_5000	OSC Control Register (OSC_CR)	8	R/W	00h	25.71.1/559

25.71.1 OSC Control Register (OSC_CR)

After OSC is enabled and starts generating the clocks, the configurations such as low power and frequency range, must not be changed.

Address: OSC_CR is 4006_5000h base + 0h offset = 4006_5000h

Bit	7	6	5	4	3	2	1	0
Read	ERCLKEN	0	EREFSTEN	0	SC2P	SC4P	SC8P	SC16P
Write								
Reset	0	0	0	0	0	0	0	0

OSC_CR field descriptions

Field	Description
7 ERCLKEN	External Reference Enable Enables external reference clock (OSCERCLK).

Table continues on the next page...

OSC_CR field descriptions (continued)

Field	Description
	0 External reference clock is inactive. 1 External reference clock is enabled.
6 Reserved	This read-only field is reserved and always has the value zero.
5 EREFSTEN	External Reference Stop Enable Controls whether or not the external reference clock (OSCERCLK) remains enabled when MCU enters Stop mode. 0 External reference clock is disabled in Stop mode. 1 External reference clock stays enabled in Stop mode if ERCLKEN is set before entering Stop mode.
4 Reserved	This read-only field is reserved and always has the value zero.
3 SC2P	Oscillator 2 pF Capacitor Load Configure Configures the oscillator load. 0 Disable the selection. 1 Add 2 pF capacitor to the oscillator load.
2 SC4P	Oscillator 4 pF Capacitor Load Configure Configures the oscillator load. 0 Disable the selection. 1 Add 4 pF capacitor to the oscillator load.
1 SC8P	Oscillator 8 pF Capacitor Load Configure Configures the oscillator load. 0 Disable the selection. 1 Add 8 pF capacitor to the oscillator load.
0 SC16P	Oscillator 16 pF Capacitor Load Configure Configures the oscillator load. 0 Disable the selection. 1 Add 16 pF capacitor to the oscillator load.

25.8 Functional Description

This following sections provide functional details of the module.

25.8.1 OSC Module States

The states of the OSC module are shown in the following figure. The states and their transitions between each other are described in this section.

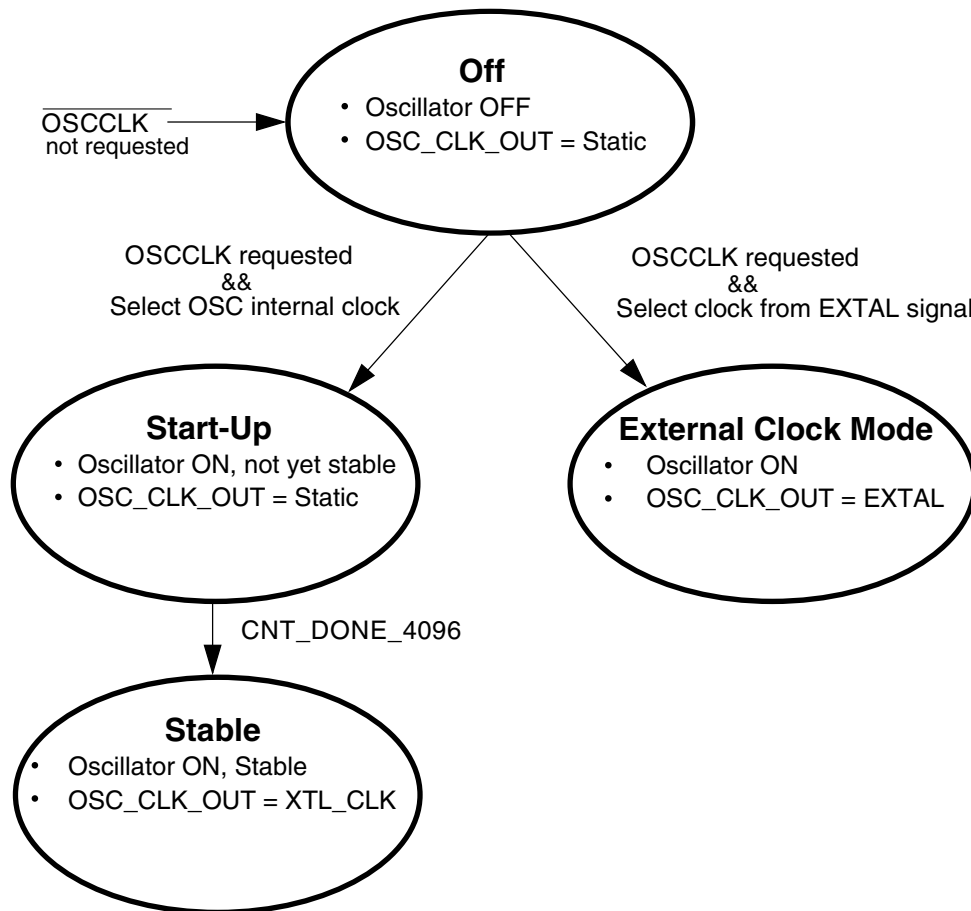

Figure 25-7. OSC Module State Diagram

NOTE

XTL_CLK is the clock generated internally from OSC circuits.

25.8.1.1 Off

The OSC enters the Off state when the system does not require OSC clocks. Upon entering this state, XTL_CLK is static unless OSC is configured to select the clock from the EXTAL pad by clearing the external reference clock selection bit. For details regarding the external reference clock source in this MCU, refer to the chip configuration chapter. The EXTAL and XTAL pins are also decoupled from all other oscillator circuitry in this state. The OSC module circuitry is configured to draw minimal current.

25.8.1.2 Oscillator Start-Up

The OSC enters start-up state when it is configured to generate clocks (internally the OSC_EN transitions high) using the internal oscillator circuits by setting the external reference clock selection bit. In this state, the OSC module is enabled and oscillations are starting up, but have not yet stabilized. When the oscillation amplitude becomes large enough to pass through the input buffer, XTL_CLK begins clocking the counter. When the counter reaches 4096 cycles of XTL_CLK, the oscillator is considered stable and XTL_CLK is passed to the output clock OSC_CLK_OUT.

25.8.1.3 Oscillator Stable

The OSC enters stable state when it is configured to generate clocks (internally the OSC_EN transitions high) using the internal oscillator circuits by setting the external reference clock selection bit and the counter reaches 4096 cycles of XTL_CLK (when CNT_DONE_4096 is high). In this state, the OSC module is producing a stable output clock on OSC_CLK_OUT. Its frequency is determined by the external components being used.

25.8.1.4 External Clock Mode

The OSC enters external clock state when it is enabled and external reference clock selection bit is cleared. For details regarding external reference clock source in this MCU, refer to the chip configuration chapter. In this state, the OSC module is set to buffer (with hysteresis) a clock from EXTAL onto the OSC_CLK_OUT. Its frequency is determined by the external clock being supplied.

25.8.2 OSC Module Modes

The OSC is a Pierce-type oscillator that supports external crystals or resonators operating over the frequency ranges shown in [Table 25-5](#). These modes assume the following conditions: OSC is enabled to generate clocks (OSC_EN=1), configured to generate clocks internally (MCG_C2[EREFS] = 1), and some or one of the other peripherals (MCG, Timer, and so on) is configured to use the oscillator output clock (OSC_CLK_OUT).

Table 25-5. Oscillator Modes

Mode	Frequency Range
Low-frequency, high-gain	f_{osc_lo} (1 kHz) up to f_{osc_lo} (32.768 kHz)
Low-frequency, low-power (VLP)	
High-frequency mode1, high-gain	$f_{osc_hi_1}$ (3 MHz) up to $f_{osc_hi_1}$ (8 MHz)
High-frequency mode1, low-power	
High-frequency mode2, high-gain	$f_{osc_hi_2}$ (8 MHz) up to $f_{osc_hi_2}$ (32 MHz)
High-frequency mode2, low-power	

NOTE

For information about low power modes of operation used in this chip and their alignment with some OSC modes, refer to the chip's Power Management details.

25.8.2.1 Low-Frequency, High-Gain Mode

In Low-frequency, high-gain mode, the oscillator uses a simple inverter-style amplifier. The gain is set to achieve rail-to-rail oscillation amplitudes.

The oscillator input buffer in this mode is single-ended. It provides low pass frequency filtering as well as hysteresis for voltage filtering and converts the output to logic levels. In this mode, the internal capacitors could be used.

25.8.2.2 Low-Frequency, Low-Power Mode

In low-frequency, low-power mode, the oscillator uses a gain control loop to minimize power consumption. As the oscillation amplitude increases, the amplifier current is reduced. This continues until a desired amplitude is achieved at steady-state. This mode provides low pass frequency filtering as well as hysteresis for voltage filtering and converts the output to logic levels. In this mode, the internal capacitors could be used, the internal feedback resistor is connected, and no external resistor should be used.

In this mode, the amplifier inputs, gain-control input, and input buffer input are all capacitively coupled for leakage tolerance (not sensitive to the DC level of EXTAL).

Also in this mode, all external components except for the resonator itself are integrated, which includes the load capacitors and feedback resistor that biases EXTAL.

25.8.2.3 High-Frequency, High-Gain Mode

In high-frequency, high-gain mode, the oscillator uses a simple inverter-style amplifier. The gain is set to achieve rail-to-rail oscillation amplitudes. This mode provides low pass frequency filtering as well as hysteresis for voltage filtering and converts the output to logic levels. In this mode, the internal capacitors could be used.

25.8.2.4 High-Frequency, Low-Power Mode

In high-frequency, low-power mode, the oscillator uses a gain control loop to minimize power consumption. As the oscillation amplitude increases, the amplifier current is reduced. This continues until a desired amplitude is achieved at steady-state. In this mode, the internal capacitors could be used, the internal feedback resistor is connected, and no external resistor should be used.

The oscillator input buffer in this mode is differential. It provides low pass frequency filtering as well as hysteresis for voltage filtering and converts the output to logic levels.

25.8.3 Counter

The oscillator output clock (OSC_CLK_OUT) is gated off until the counter has detected 4096 cycles of its input clock (XTL_CLK). After 4096 cycles are completed, the counter passes XTL_CLK onto OSC_CLK_OUT. This counting time-out is used to guarantee output clock stability.

25.8.4 Reference Clock Pin Requirements

The OSC module requires use of both the EXTAL and XTAL pins to generate an output clock in Oscillator mode, but requires only the EXTAL pin in External clock mode. The EXTAL and XTAL pins are available for I/O. For the implementation of these pins on this device, refer to the Signal Multiplexing chapter.

25.9 Reset

There is no reset state associated with the OSC module. The counter logic is reset when the OSC is not configured to generate clocks.

There are no sources of reset requests for the OSC module.

25.10 Low Power Modes Operation

When the MCU enters Stop modes, the OSC is functional depending on ERCLKEN and EREFSETN bit settings. If both these bits are set, the OSC is in operation. In Low Leakage Stop (LLS) modes, the OSC holds all register settings. If ERCLKEN and EREFSTEN bits are set before entry to Low Leakage Stop modes, the OSC is still functional in these modes. After waking up from Very Low Leakage Stop (VLLSx) modes, all OSC register bits are reset and initialization is required through software.

25.11 Interrupts

The OSC module does not generate any interrupts.

Chapter 26

RTC Oscillator

26.1 Introduction

NOTE

For the chip-specific implementation details of this module's instances see the chip configuration chapter.

The RTC oscillator module provides the clock source for the RTC. The RTC oscillator module, in conjunction with an external crystal, generates a reference clock for the RTC.

26.1.1 Features and Modes

The key features of the RTC oscillator are as follows:

- Supports 32 kHz crystals with very low power
- Consists of internal feed back resistor
- Consists of internal programmable capacitors as the Load of the oscillator
- Automatic Gain Control (AGC) to optimize power consumption

The RTC oscillator operations are described in detail in [Functional Description](#) .

26.1.2 Block Diagram

The following is the block diagram of the RTC oscillator.

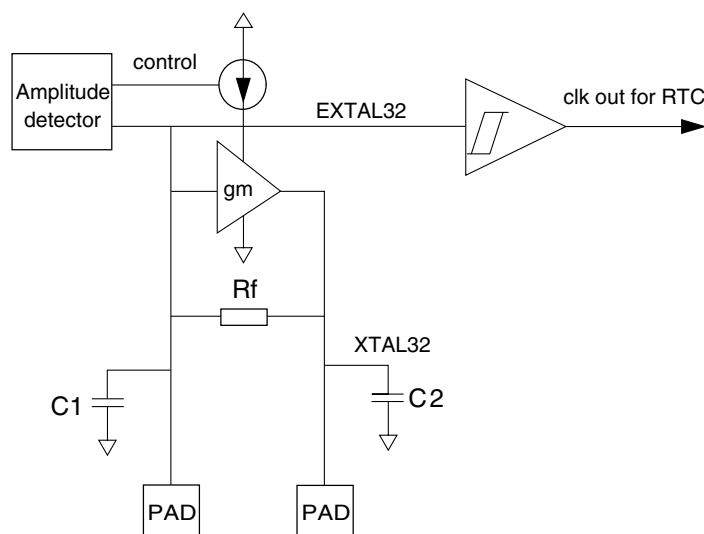

Figure 26-1. RTC Oscillator Block Diagram

26.2 RTC Signal Descriptions

The following table shows the user-accessible signals available for the RTC oscillator. See the chip-level specification to find out which signals are actually connected to the external pins.

Table 26-1. RTC Signal Descriptions

Signal	Description	I/O
EXTAL32	Oscillator Input	I
XTAL32	Oscillator Output	O

26.2.1 EXTAL32 — Oscillator Input

This signal is the analog input of the RTC oscillator.

26.2.2 XTAL32 — Oscillator Output

This signal is the analog output of the RTC oscillator module.

26.3 External Crystal Connections

The connections with a crystal is shown in the following figure. External load capacitors and feedback resistor are not required.

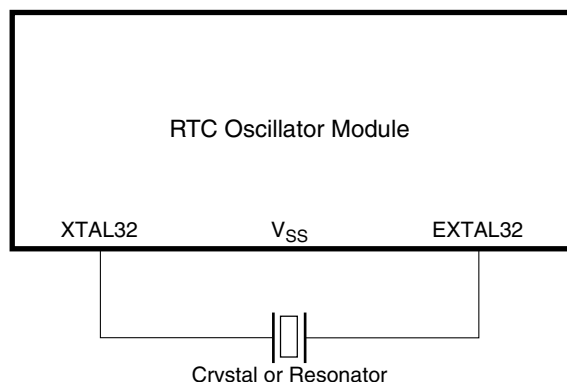

Figure 26-2. Crystal Connections

26.4 Memory Map/Register Descriptions

RTC oscillator control bits are part of the RTC registers. Refer to RTC_CR for more details.

26.5 Functional Description

As shown in [Figure 26-1](#), the module includes an amplifier which supplies the negative resistor for the RTC oscillator. The gain of the amplifier is controlled by the amplitude detector, which optimizes the power consumption. A schmitt trigger is used to translate the sine-wave generated by this oscillator to a pulse clock out, which is a reference clock for the RTC digital core.

The oscillator includes an internal feedback resistor of approximately 100 M Ω between EXTAL32 and XTAL32.

In addition, there are two programmable capacitors with this oscillator, which can be used as the Cload of the oscillator. The programmable range is from 0pF to 30pF.

26.6 Reset Overview

There is no reset state associated with the RTC oscillator.

26.7 Interrupts

The RTC oscillator does not generate any interrupts.

Chapter 27

Flash Memory Controller (FMC)

27.1 Introduction

NOTE

For the chip-specific implementation details of this module's instances see the chip configuration chapter.

The Flash Memory Controller (FMC) is a memory acceleration unit that provides:

- an interface between the device and the dual-bank nonvolatile memory.
- buffers that can accelerate flash memory transfers.

27.1.1 Overview

The Flash Memory Controller manages the interface between the device and the dual-bank flash memory. The FMC receives status information detailing the configuration of the memory and uses this information to ensure a proper interface. The following table shows the supported 8-bit, 16-bit, and 32-bit read/write operations.

Flash memory type	Read	Write
Program flash memory	x	— ¹

1. A write operation to program flash memory results in a bus error.

In addition, for bank 0 and bank 1, the FMC provides three separate mechanisms for accelerating the interface between the device and the flash memory. A 64-bit speculation buffer can prefetch the next 64-bit flash memory location, and both a 4-way, 8-set cache and a single-entry 64-bit buffer can store previously accessed flash memory data for quick access times.

27.1.2 Features

The FMC's features include:

- Interface between the device and the dual-bank flash memory:
 - 8-bit, 16-bit, and 32-bit read operations to program flash memory.
 - For bank 0 and bank 1: Read accesses to consecutive 32-bit spaces in memory return the second read data with no wait states. The memory returns 64 bits via the 32-bit bus access.
 - Crossbar master access protection for setting no access, read only access, write only access, or read/write access for each crossbar master.
- For bank 0 and bank 1: Acceleration of data transfer from program flash memory to the device:
 - 64-bit prefetch speculation buffer with controls for instruction/data access per master and bank
 - 4-way, 8-set, 64-bit line size cache for a total of thirty-two 64-bit entries with controls for replacement algorithm and lock per way for each bank
 - Single-entry buffer with enable per bank
 - Invalidation control for the speculation buffer and the single-entry buffer

27.2 Modes of operation

The FMC only operates when the device accesses the flash memory.

In terms of device power modes, the FMC only operates in run and wait modes, including VLPR and VLPW modes.

For any device power mode where the flash memory cannot be accessed, the FMC is disabled.

27.3 External signal description

The FMC has no external signals.

27.4 Memory map and register descriptions

The programming model consists of the FMC control registers and the program visible cache (data and tag/valid entries).

NOTE

Program the registers only while the flash controller is idle (for example, execute from RAM). Changing configuration settings while a flash access is in progress can lead to non-deterministic behavior.

Table 27-2. FMC register access

Registers	Read access		Write access	
	Mode	Length	Mode	Length
Control registers: PFAPR, PFB0CR, PFB1CR	Supervisor (privileged) mode or user mode	32 bits	Supervisor (privileged) mode only	8, 16, or 32 bits
Cache registers	Supervisor (privileged) mode or user mode	32 bits	Supervisor (privileged) mode only	32 bits

NOTE

Accesses to unimplemented registers within the FMC's 4 KB address space return a bus error.

The cache entries, both data and tag/valid, can be read at any time.

NOTE

System software is required to maintain memory coherence when any segment of the flash cache is programmed. For example, all buffer data associated with the reprogrammed flash should be invalidated. Accordingly, cache program visible writes must occur after a programming or erase event is completed and before the new memory image is accessed.

The cache is a 4-way, set-associative cache with 8 sets. The ways are numbered 0-3 and the sets are numbered 0-7. The following table elaborates on the tag/valid and data entries.

Table 27-3. Program visible cache registers

Cache storage	Based at offset	Contents of 32-bit read	Nomenclature	Nomenclature example
Tag	100h	13'h0, tag[18:6], 5'h0, valid	In TAGVDWxSy, x denotes the way and y denotes the set.	TAGVDW2S0 is the 13-bit tag and 1-bit valid for cache entry way 2, set 0.
Data	200h	Upper or lower word of data	In DATAWxSyU and DATAWxSyL, x denotes the way, y denotes the set, and U and L represent upper and lower word, respectively.	DATAW1S0U represents bits [63:32] of data entry way 1, set 0, and DATAW1S0L represents bits [31:0] of data entry way 1, set 0.

FMC memory map

Absolute address (hex)	Register name	Width (in bits)	Access	Reset value	Section/page
4001_F000	Flash Access Protection Register (FMC_PFAPR)	32	R/W	00F8_003Fh	27.4.1/ 579
4001_F004	Flash Bank 0 Control Register (FMC_PFB0CR)	32	R/W	3002_001Fh	27.4.2/ 582
4001_F008	Flash Bank 1 Control Register (FMC_PFB1CR)	32	R/W	3002_001Fh	27.4.3/ 584
4001_F100	Cache Tag Storage (FMC_TAGVDW0S0)	32	R/W	0000_0000h	27.4.4/ 586
4001_F104	Cache Tag Storage (FMC_TAGVDW0S1)	32	R/W	0000_0000h	27.4.4/ 586
4001_F108	Cache Tag Storage (FMC_TAGVDW0S2)	32	R/W	0000_0000h	27.4.4/ 586
4001_F10C	Cache Tag Storage (FMC_TAGVDW0S3)	32	R/W	0000_0000h	27.4.4/ 586
4001_F110	Cache Tag Storage (FMC_TAGVDW0S4)	32	R/W	0000_0000h	27.4.4/ 586
4001_F114	Cache Tag Storage (FMC_TAGVDW0S5)	32	R/W	0000_0000h	27.4.4/ 586
4001_F118	Cache Tag Storage (FMC_TAGVDW0S6)	32	R/W	0000_0000h	27.4.4/ 586
4001_F11C	Cache Tag Storage (FMC_TAGVDW0S7)	32	R/W	0000_0000h	27.4.4/ 586
4001_F120	Cache Tag Storage (FMC_TAGVDW1S0)	32	R/W	0000_0000h	27.4.5/ 587
4001_F124	Cache Tag Storage (FMC_TAGVDW1S1)	32	R/W	0000_0000h	27.4.5/ 587
4001_F128	Cache Tag Storage (FMC_TAGVDW1S2)	32	R/W	0000_0000h	27.4.5/ 587
4001_F12C	Cache Tag Storage (FMC_TAGVDW1S3)	32	R/W	0000_0000h	27.4.5/ 587
4001_F130	Cache Tag Storage (FMC_TAGVDW1S4)	32	R/W	0000_0000h	27.4.5/ 587
4001_F134	Cache Tag Storage (FMC_TAGVDW1S5)	32	R/W	0000_0000h	27.4.5/ 587
4001_F138	Cache Tag Storage (FMC_TAGVDW1S6)	32	R/W	0000_0000h	27.4.5/ 587
4001_F13C	Cache Tag Storage (FMC_TAGVDW1S7)	32	R/W	0000_0000h	27.4.5/ 587
4001_F140	Cache Tag Storage (FMC_TAGVDW2S0)	32	R/W	0000_0000h	27.4.6/ 588

Table continues on the next page...

FMC memory map (continued)

Absolute address (hex)	Register name	Width (in bits)	Access	Reset value	Section/page
4001_F144	Cache Tag Storage (FMC_TAGVDW2S1)	32	R/W	0000_0000h	27.4.6/588
4001_F148	Cache Tag Storage (FMC_TAGVDW2S2)	32	R/W	0000_0000h	27.4.6/588
4001_F14C	Cache Tag Storage (FMC_TAGVDW2S3)	32	R/W	0000_0000h	27.4.6/588
4001_F150	Cache Tag Storage (FMC_TAGVDW2S4)	32	R/W	0000_0000h	27.4.6/588
4001_F154	Cache Tag Storage (FMC_TAGVDW2S5)	32	R/W	0000_0000h	27.4.6/588
4001_F158	Cache Tag Storage (FMC_TAGVDW2S6)	32	R/W	0000_0000h	27.4.6/588
4001_F15C	Cache Tag Storage (FMC_TAGVDW2S7)	32	R/W	0000_0000h	27.4.6/588
4001_F160	Cache Tag Storage (FMC_TAGVDW3S0)	32	R/W	0000_0000h	27.4.7/589
4001_F164	Cache Tag Storage (FMC_TAGVDW3S1)	32	R/W	0000_0000h	27.4.7/589
4001_F168	Cache Tag Storage (FMC_TAGVDW3S2)	32	R/W	0000_0000h	27.4.7/589
4001_F16C	Cache Tag Storage (FMC_TAGVDW3S3)	32	R/W	0000_0000h	27.4.7/589
4001_F170	Cache Tag Storage (FMC_TAGVDW3S4)	32	R/W	0000_0000h	27.4.7/589
4001_F174	Cache Tag Storage (FMC_TAGVDW3S5)	32	R/W	0000_0000h	27.4.7/589
4001_F178	Cache Tag Storage (FMC_TAGVDW3S6)	32	R/W	0000_0000h	27.4.7/589
4001_F17C	Cache Tag Storage (FMC_TAGVDW3S7)	32	R/W	0000_0000h	27.4.7/589
4001_F200	Cache Data Storage (upper word) (FMC_DATAW0S0U)	32	R/W	0000_0000h	27.4.8/590
4001_F204	Cache Data Storage (lower word) (FMC_DATAW0S0L)	32	R/W	0000_0000h	27.4.9/591
4001_F208	Cache Data Storage (upper word) (FMC_DATAW0S1U)	32	R/W	0000_0000h	27.4.8/590
4001_F20C	Cache Data Storage (lower word) (FMC_DATAW0S1L)	32	R/W	0000_0000h	27.4.9/591
4001_F210	Cache Data Storage (upper word) (FMC_DATAW0S2U)	32	R/W	0000_0000h	27.4.8/590

Table continues on the next page...

FMC memory map (continued)

Absolute address (hex)	Register name	Width (in bits)	Access	Reset value	Section/page
4001_F214	Cache Data Storage (lower word) (FMC_DATAW0S2L)	32	R/W	0000_0000h	27.4.9/591
4001_F218	Cache Data Storage (upper word) (FMC_DATAW0S3U)	32	R/W	0000_0000h	27.4.8/590
4001_F21C	Cache Data Storage (lower word) (FMC_DATAW0S3L)	32	R/W	0000_0000h	27.4.9/591
4001_F220	Cache Data Storage (upper word) (FMC_DATAW0S4U)	32	R/W	0000_0000h	27.4.8/590
4001_F224	Cache Data Storage (lower word) (FMC_DATAW0S4L)	32	R/W	0000_0000h	27.4.9/591
4001_F228	Cache Data Storage (upper word) (FMC_DATAW0S5U)	32	R/W	0000_0000h	27.4.8/590
4001_F22C	Cache Data Storage (lower word) (FMC_DATAW0S5L)	32	R/W	0000_0000h	27.4.9/591
4001_F230	Cache Data Storage (upper word) (FMC_DATAW0S6U)	32	R/W	0000_0000h	27.4.8/590
4001_F234	Cache Data Storage (lower word) (FMC_DATAW0S6L)	32	R/W	0000_0000h	27.4.9/591
4001_F238	Cache Data Storage (upper word) (FMC_DATAW0S7U)	32	R/W	0000_0000h	27.4.8/590
4001_F23C	Cache Data Storage (lower word) (FMC_DATAW0S7L)	32	R/W	0000_0000h	27.4.9/591
4001_F240	Cache Data Storage (upper word) (FMC_DATAW1S0U)	32	R/W	0000_0000h	27.4.10/592
4001_F244	Cache Data Storage (lower word) (FMC_DATAW1S0L)	32	R/W	0000_0000h	27.4.11/593
4001_F248	Cache Data Storage (upper word) (FMC_DATAW1S1U)	32	R/W	0000_0000h	27.4.10/592
4001_F24C	Cache Data Storage (lower word) (FMC_DATAW1S1L)	32	R/W	0000_0000h	27.4.11/593
4001_F250	Cache Data Storage (upper word) (FMC_DATAW1S2U)	32	R/W	0000_0000h	27.4.10/592
4001_F254	Cache Data Storage (lower word) (FMC_DATAW1S2L)	32	R/W	0000_0000h	27.4.11/593
4001_F258	Cache Data Storage (upper word) (FMC_DATAW1S3U)	32	R/W	0000_0000h	27.4.10/592
4001_F25C	Cache Data Storage (lower word) (FMC_DATAW1S3L)	32	R/W	0000_0000h	27.4.11/593
4001_F260	Cache Data Storage (upper word) (FMC_DATAW1S4U)	32	R/W	0000_0000h	27.4.10/592

Table continues on the next page...

FMC memory map (continued)

Absolute address (hex)	Register name	Width (in bits)	Access	Reset value	Section/page
4001_F264	Cache Data Storage (lower word) (FMC_DATAW1S4L)	32	R/W	0000_0000h	27.4.11/593
4001_F268	Cache Data Storage (upper word) (FMC_DATAW1S5U)	32	R/W	0000_0000h	27.4.10/592
4001_F26C	Cache Data Storage (lower word) (FMC_DATAW1S5L)	32	R/W	0000_0000h	27.4.11/593
4001_F270	Cache Data Storage (upper word) (FMC_DATAW1S6U)	32	R/W	0000_0000h	27.4.10/592
4001_F274	Cache Data Storage (lower word) (FMC_DATAW1S6L)	32	R/W	0000_0000h	27.4.11/593
4001_F278	Cache Data Storage (upper word) (FMC_DATAW1S7U)	32	R/W	0000_0000h	27.4.10/592
4001_F27C	Cache Data Storage (lower word) (FMC_DATAW1S7L)	32	R/W	0000_0000h	27.4.11/593
4001_F280	Cache Data Storage (upper word) (FMC_DATAW2S0U)	32	R/W	0000_0000h	27.4.12/594
4001_F284	Cache Data Storage (lower word) (FMC_DATAW2S0L)	32	R/W	0000_0000h	27.4.13/595
4001_F288	Cache Data Storage (upper word) (FMC_DATAW2S1U)	32	R/W	0000_0000h	27.4.12/594
4001_F28C	Cache Data Storage (lower word) (FMC_DATAW2S1L)	32	R/W	0000_0000h	27.4.13/595
4001_F290	Cache Data Storage (upper word) (FMC_DATAW2S2U)	32	R/W	0000_0000h	27.4.12/594
4001_F294	Cache Data Storage (lower word) (FMC_DATAW2S2L)	32	R/W	0000_0000h	27.4.13/595
4001_F298	Cache Data Storage (upper word) (FMC_DATAW2S3U)	32	R/W	0000_0000h	27.4.12/594
4001_F29C	Cache Data Storage (lower word) (FMC_DATAW2S3L)	32	R/W	0000_0000h	27.4.13/595
4001_F2A0	Cache Data Storage (upper word) (FMC_DATAW2S4U)	32	R/W	0000_0000h	27.4.12/594
4001_F2A4	Cache Data Storage (lower word) (FMC_DATAW2S4L)	32	R/W	0000_0000h	27.4.13/595
4001_F2A8	Cache Data Storage (upper word) (FMC_DATAW2S5U)	32	R/W	0000_0000h	27.4.12/594
4001_F2AC	Cache Data Storage (lower word) (FMC_DATAW2S5L)	32	R/W	0000_0000h	27.4.13/595
4001_F2B0	Cache Data Storage (upper word) (FMC_DATAW2S6U)	32	R/W	0000_0000h	27.4.12/594

Table continues on the next page...

FMC memory map (continued)

Absolute address (hex)	Register name	Width (in bits)	Access	Reset value	Section/page
4001_F2B4	Cache Data Storage (lower word) (FMC_DATAW2S6L)	32	R/W	0000_0000h	27.4.13/595
4001_F2B8	Cache Data Storage (upper word) (FMC_DATAW2S7U)	32	R/W	0000_0000h	27.4.12/594
4001_F2BC	Cache Data Storage (lower word) (FMC_DATAW2S7L)	32	R/W	0000_0000h	27.4.13/595
4001_F2C0	Cache Data Storage (upper word) (FMC_DATAW3S0U)	32	R/W	0000_0000h	27.4.14/596
4001_F2C4	Cache Data Storage (lower word) (FMC_DATAW3S0L)	32	R/W	0000_0000h	27.4.15/597
4001_F2C8	Cache Data Storage (upper word) (FMC_DATAW3S1U)	32	R/W	0000_0000h	27.4.14/596
4001_F2CC	Cache Data Storage (lower word) (FMC_DATAW3S1L)	32	R/W	0000_0000h	27.4.15/597
4001_F2D0	Cache Data Storage (upper word) (FMC_DATAW3S2U)	32	R/W	0000_0000h	27.4.14/596
4001_F2D4	Cache Data Storage (lower word) (FMC_DATAW3S2L)	32	R/W	0000_0000h	27.4.15/597
4001_F2D8	Cache Data Storage (upper word) (FMC_DATAW3S3U)	32	R/W	0000_0000h	27.4.14/596
4001_F2DC	Cache Data Storage (lower word) (FMC_DATAW3S3L)	32	R/W	0000_0000h	27.4.15/597
4001_F2E0	Cache Data Storage (upper word) (FMC_DATAW3S4U)	32	R/W	0000_0000h	27.4.14/596
4001_F2E4	Cache Data Storage (lower word) (FMC_DATAW3S4L)	32	R/W	0000_0000h	27.4.15/597
4001_F2E8	Cache Data Storage (upper word) (FMC_DATAW3S5U)	32	R/W	0000_0000h	27.4.14/596
4001_F2EC	Cache Data Storage (lower word) (FMC_DATAW3S5L)	32	R/W	0000_0000h	27.4.15/597
4001_F2F0	Cache Data Storage (upper word) (FMC_DATAW3S6U)	32	R/W	0000_0000h	27.4.14/596
4001_F2F4	Cache Data Storage (lower word) (FMC_DATAW3S6L)	32	R/W	0000_0000h	27.4.15/597
4001_F2F8	Cache Data Storage (upper word) (FMC_DATAW3S7U)	32	R/W	0000_0000h	27.4.14/596
4001_F2FC	Cache Data Storage (lower word) (FMC_DATAW3S7L)	32	R/W	0000_0000h	27.4.15/597

27.4.1 Flash Access Protection Register (FMC_PFAPR)

Address: FMC_PFAPR is 4001_F000h base + 0h offset = 4001_F000h

Bit	31	30	29	28	27	26	25	24	23	22	21	20	19	18	17	16
R	0								M7PFD	M6PFD	M5PFD	M4PFD	M3PFD	M2PFD	M1PFD	M0PFD
W	[Shaded]															
Reset	0	0	0	0	0	0	0	0	1	1	1	1	1	0	0	0
Bit	15	14	13	12	11	10	9	8	7	6	5	4	3	2	1	0
R	M7AP[1:0]		M6AP[1:0]		M5AP[1:0]		M4AP[1:0]		M3AP[1:0]		M2AP[1:0]		M1AP[1:0]		M0AP[1:0]	
W																
Reset	0	0	0	0	0	0	0	0	0	0	1	1	1	1	1	1

FMC_PFAPR field descriptions

Field	Description
31–24 Reserved	This read-only field is reserved and always has the value zero.
23 M7PFD	<p>Master 7 Prefetch Disable</p> <p>These bits control whether prefetching is enabled based on the logical number of the requesting crossbar switch master. This field is further qualified by the PFBnCR[BxDPE,BxIPE] bits.</p> <p>0 Prefetching for this master is enabled. 1 Prefetching for this master is disabled.</p>
22 M6PFD	<p>Master 6 Prefetch Disable</p> <p>These bits control whether prefetching is enabled based on the logical number of the requesting crossbar switch master. This field is further qualified by the PFBnCR[BxDPE,BxIPE] bits.</p> <p>0 Prefetching for this master is enabled. 1 Prefetching for this master is disabled.</p>
21 M5PFD	<p>Master 5 Prefetch Disable</p> <p>These bits control whether prefetching is enabled based on the logical number of the requesting crossbar switch master. This field is further qualified by the PFBnCR[BxDPE,BxIPE] bits.</p> <p>0 Prefetching for this master is enabled. 1 Prefetching for this master is disabled.</p>
20 M4PFD	<p>Master 4 Prefetch Disable</p> <p>These bits control whether prefetching is enabled based on the logical number of the requesting crossbar switch master. This field is further qualified by the PFBnCR[BxDPE,BxIPE] bits.</p>

Table continues on the next page...

FMC_PFAPR field descriptions (continued)

Field	Description
	<p>0 Prefetching for this master is enabled.</p> <p>1 Prefetching for this master is disabled.</p>
19 M3PFD	<p>Master 3 Prefetch Disable</p> <p>These bits control whether prefetching is enabled based on the logical number of the requesting crossbar switch master. This field is further qualified by the PFBnCR[BxDPE,BxIPE] bits.</p> <p>0 Prefetching for this master is enabled.</p> <p>1 Prefetching for this master is disabled.</p>
18 M2PFD	<p>Master 2 Prefetch Disable</p> <p>These bits control whether prefetching is enabled based on the logical number of the requesting crossbar switch master. This field is further qualified by the PFBnCR[BxDPE,BxIPE] bits.</p> <p>0 Prefetching for this master is enabled.</p> <p>1 Prefetching for this master is disabled.</p>
17 M1PFD	<p>Master 1 Prefetch Disable</p> <p>These bits control whether prefetching is enabled based on the logical number of the requesting crossbar switch master. This field is further qualified by the PFBnCR[BxDPE,BxIPE] bits.</p> <p>0 Prefetching for this master is enabled.</p> <p>1 Prefetching for this master is disabled.</p>
16 M0PFD	<p>Master 0 Prefetch Disable</p> <p>These bits control whether prefetching is enabled based on the logical number of the requesting crossbar switch master. This field is further qualified by the PFBnCR[BxDPE,BxIPE] bits.</p> <p>0 Prefetching for this master is enabled.</p> <p>1 Prefetching for this master is disabled.</p>
15–14 M7AP[1:0]	<p>Master 7 Access Protection</p> <p>This field controls whether read and write access to the flash are allowed based on the logical master number of the requesting crossbar switch master.</p> <p>00 No access may be performed by this master.</p> <p>01 Only read accesses may be performed by this master.</p> <p>10 Only write accesses may be performed by this master.</p> <p>11 Both read and write accesses may be performed by this master.</p>
13–12 M6AP[1:0]	<p>Master 6 Access Protection</p> <p>This field controls whether read and write access to the flash are allowed based on the logical master number of the requesting crossbar switch master.</p> <p>00 No access may be performed by this master</p> <p>01 Only read accesses may be performed by this master</p> <p>10 Only write accesses may be performed by this master</p> <p>11 Both read and write accesses may be performed by this master</p>
11–10 M5AP[1:0]	<p>Master 5 Access Protection</p>

Table continues on the next page...

FMC_PFAPR field descriptions (continued)

Field	Description
	This field controls whether read and write access to the flash are allowed based on the logical master number of the requesting crossbar switch master. 00 No access may be performed by this master 01 Only read accesses may be performed by this master 10 Only write accesses may be performed by this master 11 Both read and write accesses may be performed by this master
9–8 M4AP[1:0]	Master 4 Access Protection This field controls whether read and write access to the flash are allowed based on the logical master number of the requesting crossbar switch master. 00 No access may be performed by this master 01 Only read accesses may be performed by this master 10 Only write accesses may be performed by this master 11 Both read and write accesses may be performed by this master
7–6 M3AP[1:0]	Master 3 Access Protection This field controls whether read and write access to the flash are allowed based on the logical master number of the requesting crossbar switch master. 00 No access may be performed by this master 01 Only read accesses may be performed by this master 10 Only write accesses may be performed by this master 11 Both read and write accesses may be performed by this master
5–4 M2AP[1:0]	Master 2 Access Protection This field controls whether read and write access to the flash are allowed based on the logical master number of the requesting crossbar switch master. 00 No access may be performed by this master 01 Only read accesses may be performed by this master 10 Only write accesses may be performed by this master 11 Both read and write accesses may be performed by this master
3–2 M1AP[1:0]	Master 1 Access Protection This field controls whether read and write access to the flash are allowed based on the logical master number of the requesting crossbar switch master. 00 No access may be performed by this master 01 Only read accesses may be performed by this master 10 Only write accesses may be performed by this master 11 Both read and write accesses may be performed by this master
1–0 M0AP[1:0]	Master 0 Access Protection This field controls whether read and write access to the flash are allowed based on the logical master number of the requesting crossbar switch master. 00 No access may be performed by this master 01 Only read accesses may be performed by this master

Table continues on the next page...

FMC_PFAPR field descriptions (continued)

Field	Description
10	Only write accesses may be performed by this master
11	Both read and write accesses may be performed by this master

27.4.2 Flash Bank 0 Control Register (FMC_PFB0CR)

Address: FMC_PFB0CR is 4001_F000h base + 4h offset = 4001_F004h

Bit	31	30	29	28	27	26	25	24	23	22	21	20	19	18	17	16	
R	B0RWSC[3:0]				CLCK_WAY[3:0]				0				0	B0MW[1:0]		0	
W									CINV_WAY[3:0]				S_B_INV				
Reset	0	0	1	1	0	0	0	0	0	0	0	0	0	0	0	1	0
Bit	15	14	13	12	11	10	9	8	7	6	5	4	3	2	1	0	
R	0								CRC[2:0]			B0DCE	B0ICE	B0DPE	B0IPE	B0SEBE	
W																	
Reset	0	0	0	0	0	0	0	0	0	0	0	1	1	1	1	1	

FMC_PFB0CR field descriptions

Field	Description
31–28 B0RWSC[3:0]	<p>Bank 0 Read Wait State Control</p> <p>This read-only field defines the number of wait states required to access the bank 0 flash memory.</p> <p>The relationship between the read access time of the flash array (expressed in system clock cycles) and RWSC is defined as:</p> <p>Access time of flash array [system clocks] = RWSC + 1</p> <p>The FMC automatically calculates this value based on the ratio of the system clock speed to the flash clock speed. For example, when this ratio is 4:1, the field's value is 3h.</p>
27–24 CLCK_WAY[3:0]	<p>Cache Lock Way x</p> <p>These bits determine if the given cache way is locked such that its contents will not be displaced by future misses.</p> <p>The bit setting definitions are for each bit in the field.</p> <p>0 Cache way is unlocked and may be displaced 1 Cache way is locked and its contents are not displaced</p>
23–20 CINV_WAY[3:0]	<p>Cache Invalidate Way x</p> <p>These bits determine if the given cache way is to be invalidated (cleared). When a bit within this field is written, the corresponding cache way is immediately invalidated: the way's tag, data, and valid contents are cleared. This field always reads as zero.</p>

Table continues on the next page...

FMC_PFB0CR field descriptions (continued)

Field	Description
	<p>Cache invalidation takes precedence over locking. The cache is invalidated by system reset. System software is required to maintain memory coherency when any segment of the flash memory is programmed or erased. Accordingly, cache invalidations must occur after a programming or erase event is completed and before the new memory image is accessed.</p> <p>The bit setting definitions are for each bit in the field.</p> <p>0 No cache way invalidation for the corresponding cache 1 Invalidate cache way for the corresponding cache: clear the tag, data, and vld bits of ways selected</p>
19 S_B_INV	<p>Invalidate Prefetch Speculation Buffer</p> <p>This bit determines if the FMC's prefetch speculation buffer and the single entry page buffer are to be invalidated (cleared). When this bit is written, the speculation buffer and single entry buffer are immediately cleared. This bit always reads as zero.</p> <p>0 Speculation buffer and single entry buffer are not affected. 1 Invalidate (clear) speculation buffer and single entry buffer.</p>
18–17 B0MW[1:0]	<p>Bank 0 Memory Width</p> <p>This read-only field defines the width of the bank 0 memory.</p> <p>00 32 bits 01 64 bits 1x Reserved</p>
16 Reserved	This read-only field is reserved and always has the value zero.
15–8 Reserved	This read-only field is reserved and always has the value zero.
7–5 CRC[2:0]	<p>Cache Replacement Control</p> <p>This 3-bit field defines the replacement algorithm for accesses that are cached.</p> <p>000 LRU replacement algorithm per set across all four ways 001 Reserved 010 Independent LRU with ways [0-1] for ifetches, [2-3] for data 011 Independent LRU with ways [0-2] for ifetches, [3] for data 1xx Reserved</p>
4 B0DCE	<p>Bank 0 Data Cache Enable</p> <p>This bit controls whether data references are loaded into the cache.</p> <p>0 Do not cache data references. 1 Cache data references.</p>
3 B0ICE	<p>Bank 0 Instruction Cache Enable</p> <p>This bit controls whether instruction fetches are loaded into the cache.</p> <p>0 Do not cache instruction fetches. 1 Cache instruction fetches.</p>

Table continues on the next page...

FMC_PFB0CR field descriptions (continued)

Field	Description
2 B0DPE	Bank 0 Data Prefetch Enable This bit controls whether prefetches (or speculative accesses) are initiated in response to data references. 0 Do not prefetch in response to data references. 1 Enable prefetches in response to data references.
1 B0IPE	Bank 0 Instruction Prefetch Enable This bit controls whether prefetches (or speculative accesses) are initiated in response to instruction fetches. 0 Do not prefetch in response to instruction fetches. 1 Enable prefetches in response to instruction fetches.
0 B0SEBE	Bank 0 Single Entry Buffer Enable This bit controls whether the single entry page buffer is enabled in response to flash read accesses. Its operation is independent from bank 1's cache. A high-to-low transition of this enable forces the page buffer to be invalidated. 0 Single entry buffer is disabled. 1 Single entry buffer is enabled.

27.4.3 Flash Bank 1 Control Register (FMC_PFB1CR)

This register has a format similar to that for PFB0CR, except it controls the operation of flash bank 1, and the "global" cache control fields are empty.

Address: FMC_PFB1CR is 4001_F000h base + 8h offset = 4001_F008h

Bit	31	30	29	28	27	26	25	24	23	22	21	20	19	18	17	16
R	B1RWSC[3:0]				0								B1MW[1:0]		0	
W	[Shaded]															
Reset	0	0	1	1	0	0	0	0	0	0	0	0	0	0	1	0
Bit	15	14	13	12	11	10	9	8	7	6	5	4	3	2	1	0
R	0								0			B1DCE	B1ICE	B1DPE	B1IPE	B1SEBE
W	[Shaded]											B1DCE	B1ICE	B1DPE	B1IPE	B1SEBE
Reset	0	0	0	0	0	0	0	0	0	0	0	1	1	1	1	1

FMC_PFB1CR field descriptions

Field	Description
31–28 B1RWSC[3:0]	Bank 1 Read Wait State Control

Table continues on the next page...

FMC_PFB1CR field descriptions (continued)

Field	Description
	This read-only field defines the number of wait states required to access the bank 1 flash memory. The relationship between the read access time of the flash array (expressed in system clock cycles) and RWSC is defined as: Access time of flash array [system clocks] = RWSC + 1 The FMC automatically calculates this value based on the ratio of the system clock speed to the flash clock speed. For example, when this ratio is 4:1, the field's value is 3h.
27–19 Reserved	This read-only field is reserved and always has the value zero.
18–17 B1MW[1:0]	Bank 1 Memory Width This read-only field defines the width of the bank 1 memory. 00 32 bits 01 64 bits 10 Reserved 11 Reserved
16 Reserved	This read-only field is reserved and always has the value zero.
15–8 Reserved	This read-only field is reserved and always has the value zero.
7–5 Reserved	This read-only field is reserved and always has the value zero.
4 B1DCE	Bank 1 Data Cache Enable This bit controls whether data references are loaded into the cache. 0 Do not cache data references. 1 Cache data references.
3 B1ICE	Bank 1 Instruction Cache Enable This bit controls whether instruction fetches are loaded into the cache. 0 Do not cache instruction fetches. 1 Cache instruction fetches.
2 B1DPE	Bank 1 Data Prefetch Enable This bit controls whether prefetches (or speculative accesses) are initiated in response to data references. 0 Do not prefetch in response to data references. 1 Enable prefetches in response to data references.
1 B1IPE	Bank 1 Instruction Prefetch Enable This bit controls whether prefetches (or speculative accesses) are initiated in response to instruction fetches. 0 Do not prefetch in response to instruction fetches. 1 Enable prefetches in response to instruction fetches.

Table continues on the next page...

FMC_PFB1CR field descriptions (continued)

Field	Description
0 B1SEBE	<p>Bank 1 Single Entry Buffer Enable</p> <p>This bit controls whether the single entry buffer is enabled in response to flash read accesses. Its operation is independent from bank 0's cache.</p> <p>A high-to-low transition of this enable forces the page buffer to be invalidated.</p> <p>0 Single entry buffer is disabled. 1 Single entry buffer is enabled.</p>

27.4.4 Cache Tag Storage (FMC_TAGVDW0Sn)

The 32-entry cache is a 4-way, set-associative cache with 8 sets. The ways are numbered 0-3 and the sets are numbered 0-7. In TAGVDWxSy, x denotes the way, and y denotes the set. This section represents tag/vld information for all 8 sets (n=0-7) in way 0.

Addresses: FMC_TAGVDW0S0 is 4001_F000h base + 100h offset = 4001_F100h

FMC_TAGVDW0S1 is 4001_F000h base + 104h offset = 4001_F104h

FMC_TAGVDW0S2 is 4001_F000h base + 108h offset = 4001_F108h

FMC_TAGVDW0S3 is 4001_F000h base + 10Ch offset = 4001_F10Ch

FMC_TAGVDW0S4 is 4001_F000h base + 110h offset = 4001_F110h

FMC_TAGVDW0S5 is 4001_F000h base + 114h offset = 4001_F114h

FMC_TAGVDW0S6 is 4001_F000h base + 118h offset = 4001_F118h

FMC_TAGVDW0S7 is 4001_F000h base + 11Ch offset = 4001_F11Ch

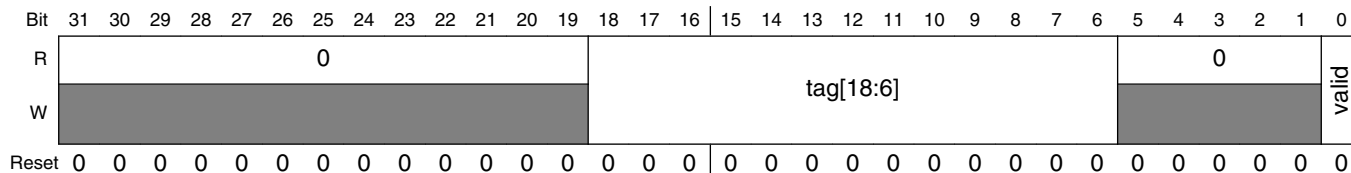

FMC_TAGVDW0Sn field descriptions

Field	Description
31–19 Reserved	This read-only field is reserved and always has the value zero.
18–6 tag[18:6]	13-bit tag for cache entry
5–1 Reserved	This read-only field is reserved and always has the value zero.
0 valid	1-bit valid for cache entry

27.4.5 Cache Tag Storage (FMC_TAGVDW1Sn)

The 32-entry cache is a 4-way, set-associative cache with 8 sets. The ways are numbered 0-3 and the sets are numbered 0-7. In TAGVDWxSy, x denotes the way, and y denotes the set. This section represents tag/vld information for all 8 sets (n=0-7) in way 1.

- Addresses: FMC_TAGVDW1S0 is 4001_F000h base + 120h offset = 4001_F120h
- FMC_TAGVDW1S1 is 4001_F000h base + 124h offset = 4001_F124h
- FMC_TAGVDW1S2 is 4001_F000h base + 128h offset = 4001_F128h
- FMC_TAGVDW1S3 is 4001_F000h base + 12Ch offset = 4001_F12Ch
- FMC_TAGVDW1S4 is 4001_F000h base + 130h offset = 4001_F130h
- FMC_TAGVDW1S5 is 4001_F000h base + 134h offset = 4001_F134h
- FMC_TAGVDW1S6 is 4001_F000h base + 138h offset = 4001_F138h
- FMC_TAGVDW1S7 is 4001_F000h base + 13Ch offset = 4001_F13Ch

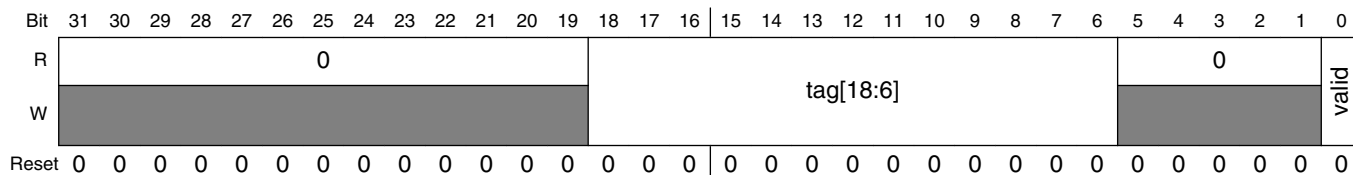

FMC_TAGVDW1Sn field descriptions

Field	Description
31–19 Reserved	This read-only field is reserved and always has the value zero.
18–6 tag[18:6]	13-bit tag for cache entry
5–1 Reserved	This read-only field is reserved and always has the value zero.
0 valid	1-bit valid for cache entry

27.4.6 Cache Tag Storage (FMC_TAGVDW2Sn)

The 32-entry cache is a 4-way, set-associative cache with 8 sets. The ways are numbered 0-3 and the sets are numbered 0-7. In TAGVDWxSy, x denotes the way, and y denotes the set. This section represents tag/vld information for all 8 sets (n=0-7) in way 2.

- Addresses: FMC_TAGVDW2S0 is 4001_F000h base + 140h offset = 4001_F140h
- FMC_TAGVDW2S1 is 4001_F000h base + 144h offset = 4001_F144h
- FMC_TAGVDW2S2 is 4001_F000h base + 148h offset = 4001_F148h
- FMC_TAGVDW2S3 is 4001_F000h base + 14Ch offset = 4001_F14Ch
- FMC_TAGVDW2S4 is 4001_F000h base + 150h offset = 4001_F150h
- FMC_TAGVDW2S5 is 4001_F000h base + 154h offset = 4001_F154h
- FMC_TAGVDW2S6 is 4001_F000h base + 158h offset = 4001_F158h
- FMC_TAGVDW2S7 is 4001_F000h base + 15Ch offset = 4001_F15Ch

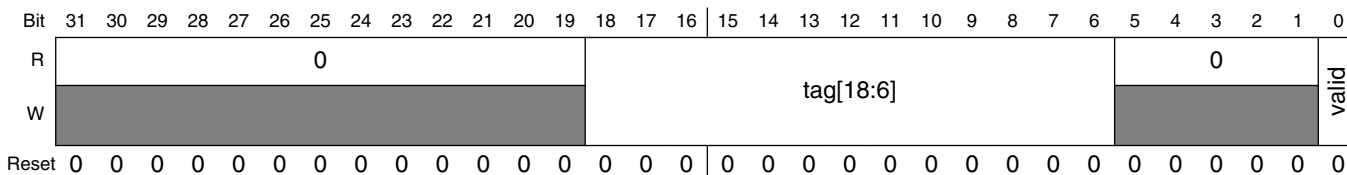

FMC_TAGVDW2Sn field descriptions

Field	Description
31–19 Reserved	This read-only field is reserved and always has the value zero.
18–6 tag[18:6]	13-bit tag for cache entry
5–1 Reserved	This read-only field is reserved and always has the value zero.
0 valid	1-bit valid for cache entry

27.4.7 Cache Tag Storage (FMC_TAGVDW3Sn)

The 32-entry cache is a 4-way, set-associative cache with 8 sets. The ways are numbered 0-3 and the sets are numbered 0-7. In TAGVDWxSy, x denotes the way, and y denotes the set. This section represents tag/vld information for all 8 sets (n=0-7) in way 3.

- Addresses: FMC_TAGVDW3S0 is 4001_F000h base + 160h offset = 4001_F160h
- FMC_TAGVDW3S1 is 4001_F000h base + 164h offset = 4001_F164h
- FMC_TAGVDW3S2 is 4001_F000h base + 168h offset = 4001_F168h
- FMC_TAGVDW3S3 is 4001_F000h base + 16Ch offset = 4001_F16Ch
- FMC_TAGVDW3S4 is 4001_F000h base + 170h offset = 4001_F170h
- FMC_TAGVDW3S5 is 4001_F000h base + 174h offset = 4001_F174h
- FMC_TAGVDW3S6 is 4001_F000h base + 178h offset = 4001_F178h
- FMC_TAGVDW3S7 is 4001_F000h base + 17Ch offset = 4001_F17Ch

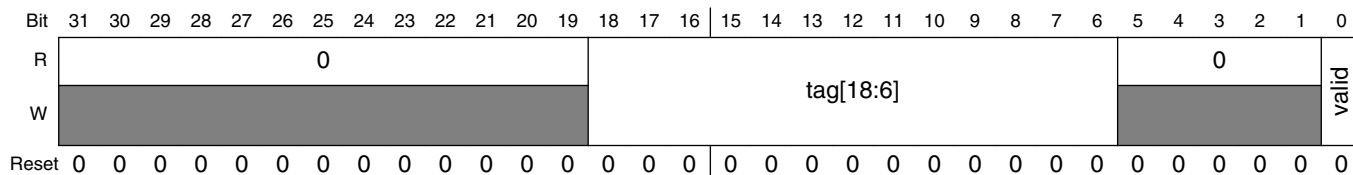

FMC_TAGVDW3Sn field descriptions

Field	Description
31–19 Reserved	This read-only field is reserved and always has the value zero.
18–6 tag[18:6]	13-bit tag for cache entry
5–1 Reserved	This read-only field is reserved and always has the value zero.
0 valid	1-bit valid for cache entry

27.4.8 Cache Data Storage (upper word) (FMC_DATAW0SU)

The cache of 64-bit entries is a 4-way, set-associative cache with 8 sets. The ways are numbered 0-3 and the sets are numbered 0-7. In DATAWxSyU and DATAWxSyL, x denotes the way, y denotes the set, and U and L represent upper and lower word, respectively. This section represents data for the upper word (bits [63:32]) of all 8 sets (n=0-7) in way 0.

- Addresses: FMC_DATAW0S0U is 4001_F000h base + 200h offset = 4001_F200h
- FMC_DATAW0S1U is 4001_F000h base + 208h offset = 4001_F208h
- FMC_DATAW0S2U is 4001_F000h base + 210h offset = 4001_F210h
- FMC_DATAW0S3U is 4001_F000h base + 218h offset = 4001_F218h
- FMC_DATAW0S4U is 4001_F000h base + 220h offset = 4001_F220h
- FMC_DATAW0S5U is 4001_F000h base + 228h offset = 4001_F228h
- FMC_DATAW0S6U is 4001_F000h base + 230h offset = 4001_F230h
- FMC_DATAW0S7U is 4001_F000h base + 238h offset = 4001_F238h

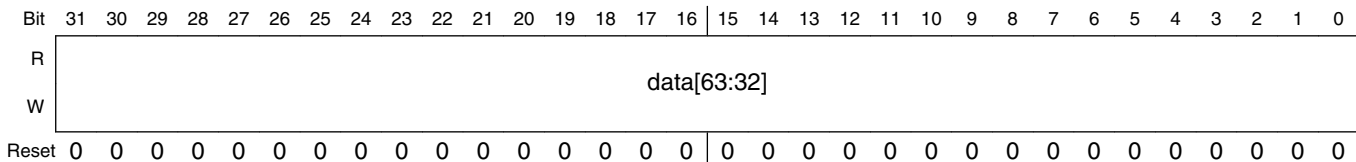

FMC_DATAW0SnU field descriptions

Field	Description
31–0 data[63:32]	Bits [63:32] of data entry

27.4.9 Cache Data Storage (lower word) (FMC_DATAW0SL)

The cache of 64-bit entries is a 4-way, set-associative cache with 8 sets. The ways are numbered 0-3 and the sets are numbered 0-7. In DATAWxSyU and DATAWxSyL, x denotes the way, y denotes the set, and U and L represent upper and lower word, respectively. This section represents data for the lower word (bits [31:0]) of all 8 sets (n=0-7) in way 0.

- Addresses: FMC_DATAW0S0L is 4001_F000h base + 204h offset = 4001_F204h
- FMC_DATAW0S1L is 4001_F000h base + 20Ch offset = 4001_F20Ch
- FMC_DATAW0S2L is 4001_F000h base + 214h offset = 4001_F214h
- FMC_DATAW0S3L is 4001_F000h base + 21Ch offset = 4001_F21Ch
- FMC_DATAW0S4L is 4001_F000h base + 224h offset = 4001_F224h
- FMC_DATAW0S5L is 4001_F000h base + 22Ch offset = 4001_F22Ch
- FMC_DATAW0S6L is 4001_F000h base + 234h offset = 4001_F234h
- FMC_DATAW0S7L is 4001_F000h base + 23Ch offset = 4001_F23Ch

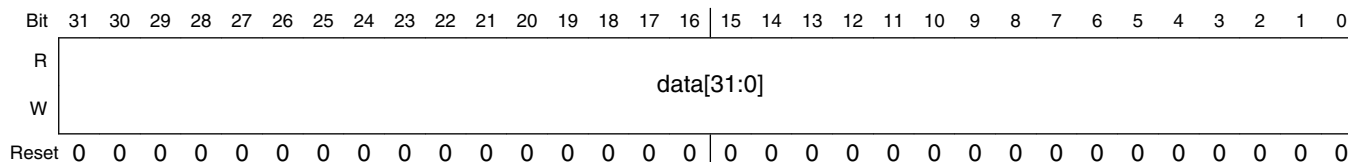

FMC_DATAW0SnL field descriptions

Field	Description
31–0 data[31:0]	Bits [31:0] of data entry

27.4.10 Cache Data Storage (upper word) (FMC_DATAW1SU)

The cache of 64-bit entries is a 4-way, set-associative cache with 8 sets. The ways are numbered 0-3 and the sets are numbered 0-7. In DATAWxSyU and DATAWxSyL, x denotes the way, y denotes the set, and U and L represent upper and lower word, respectively. This section represents data for the upper word (bits [63:32]) of all 8 sets (n=0-7) in way 1.

- Addresses: FMC_DATAW1S0U is 4001_F000h base + 240h offset = 4001_F240h
- FMC_DATAW1S1U is 4001_F000h base + 248h offset = 4001_F248h
- FMC_DATAW1S2U is 4001_F000h base + 250h offset = 4001_F250h
- FMC_DATAW1S3U is 4001_F000h base + 258h offset = 4001_F258h
- FMC_DATAW1S4U is 4001_F000h base + 260h offset = 4001_F260h
- FMC_DATAW1S5U is 4001_F000h base + 268h offset = 4001_F268h
- FMC_DATAW1S6U is 4001_F000h base + 270h offset = 4001_F270h
- FMC_DATAW1S7U is 4001_F000h base + 278h offset = 4001_F278h

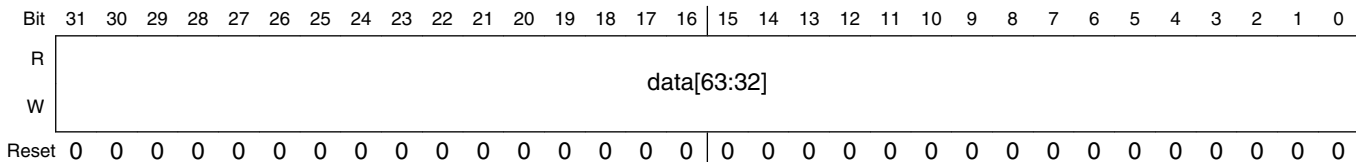

FMC_DATAW1SnU field descriptions

Field	Description
31–0 data[63:32]	Bits [63:32] of data entry

27.4.11 Cache Data Storage (lower word) (FMC_DATAW1SL)

The cache of 64-bit entries is a 4-way, set-associative cache with 8 sets. The ways are numbered 0-3 and the sets are numbered 0-7. In DATAW_xS_yU and DATAW_xS_yL, x denotes the way, y denotes the set, and U and L represent upper and lower word, respectively. This section represents data for the lower word (bits [31:0]) of all 8 sets (n=0-7) in way 1.

- Addresses: FMC_DATAW1S0L is 4001_F000h base + 244h offset = 4001_F244h
- FMC_DATAW1S1L is 4001_F000h base + 24Ch offset = 4001_F24Ch
- FMC_DATAW1S2L is 4001_F000h base + 254h offset = 4001_F254h
- FMC_DATAW1S3L is 4001_F000h base + 25Ch offset = 4001_F25Ch
- FMC_DATAW1S4L is 4001_F000h base + 264h offset = 4001_F264h
- FMC_DATAW1S5L is 4001_F000h base + 26Ch offset = 4001_F26Ch
- FMC_DATAW1S6L is 4001_F000h base + 274h offset = 4001_F274h
- FMC_DATAW1S7L is 4001_F000h base + 27Ch offset = 4001_F27Ch

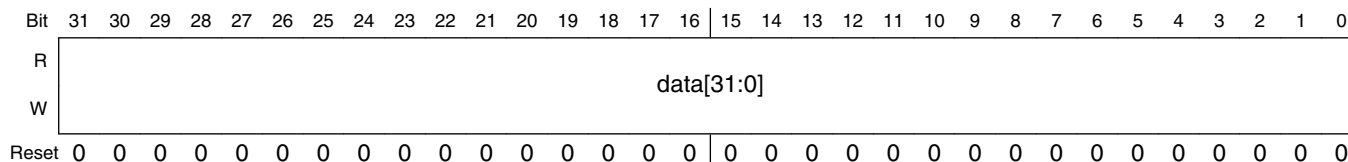

FMC_DATAW1S_nL field descriptions

Field	Description
31–0 data[31:0]	Bits [31:0] of data entry

27.4.12 Cache Data Storage (upper word) (FMC_DATAW2SU)

The cache of 64-bit entries is a 4-way, set-associative cache with 8 sets. The ways are numbered 0-3 and the sets are numbered 0-7. In DATAWxSyU and DATAWxSyL, x denotes the way, y denotes the set, and U and L represent upper and lower word, respectively. This section represents data for the upper word (bits [63:32]) of all 8 sets (n=0-7) in way 2.

- Addresses: FMC_DATAW2S0U is 4001_F000h base + 280h offset = 4001_F280h
- FMC_DATAW2S1U is 4001_F000h base + 288h offset = 4001_F288h
- FMC_DATAW2S2U is 4001_F000h base + 290h offset = 4001_F290h
- FMC_DATAW2S3U is 4001_F000h base + 298h offset = 4001_F298h
- FMC_DATAW2S4U is 4001_F000h base + 2A0h offset = 4001_F2A0h
- FMC_DATAW2S5U is 4001_F000h base + 2A8h offset = 4001_F2A8h
- FMC_DATAW2S6U is 4001_F000h base + 2B0h offset = 4001_F2B0h
- FMC_DATAW2S7U is 4001_F000h base + 2B8h offset = 4001_F2B8h

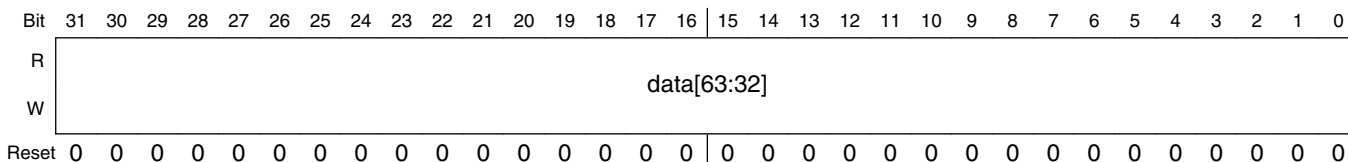

FMC_DATAW2SnU field descriptions

Field	Description
31–0 data[63:32]	Bits [63:32] of data entry

27.4.13 Cache Data Storage (lower word) (FMC_DATAW2SL)

The cache of 64-bit entries is a 4-way, set-associative cache with 8 sets. The ways are numbered 0-3 and the sets are numbered 0-7. In DATAW_xS_yU and DATAW_xS_yL, x denotes the way, y denotes the set, and U and L represent upper and lower word, respectively. This section represents data for the lower word (bits [31:0]) of all 8 sets (n=0-7) in way 2.

- Addresses: FMC_DATAW2S0L is 4001_F000h base + 284h offset = 4001_F284h
- FMC_DATAW2S1L is 4001_F000h base + 28Ch offset = 4001_F28Ch
- FMC_DATAW2S2L is 4001_F000h base + 294h offset = 4001_F294h
- FMC_DATAW2S3L is 4001_F000h base + 29Ch offset = 4001_F29Ch
- FMC_DATAW2S4L is 4001_F000h base + 2A4h offset = 4001_F2A4h
- FMC_DATAW2S5L is 4001_F000h base + 2ACh offset = 4001_F2ACh
- FMC_DATAW2S6L is 4001_F000h base + 2B4h offset = 4001_F2B4h
- FMC_DATAW2S7L is 4001_F000h base + 2BCh offset = 4001_F2BCh

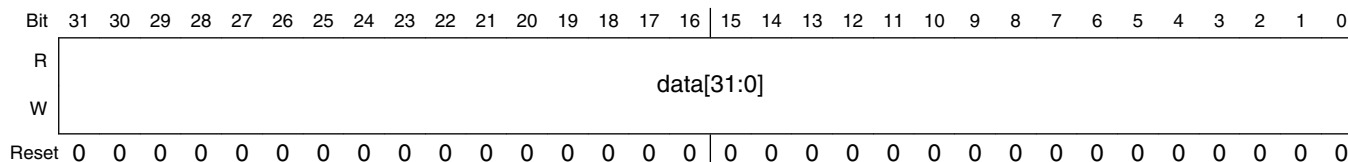

FMC_DATAW2S_nL field descriptions

Field	Description
31–0 data[31:0]	Bits [31:0] of data entry

27.4.14 Cache Data Storage (upper word) (FMC_DATAW3SU)

The cache of 64-bit entries is a 4-way, set-associative cache with 8 sets. The ways are numbered 0-3 and the sets are numbered 0-7. In DATAW_xS_yU and DATAW_xS_yL, x denotes the way, y denotes the set, and U and L represent upper and lower word, respectively. This section represents data for the upper word (bits [63:32]) of all 8 sets (n=0-7) in way 3.

- Addresses: FMC_DATAW3S0U is 4001_F000h base + 2C0h offset = 4001_F2C0h
- FMC_DATAW3S1U is 4001_F000h base + 2C8h offset = 4001_F2C8h
- FMC_DATAW3S2U is 4001_F000h base + 2D0h offset = 4001_F2D0h
- FMC_DATAW3S3U is 4001_F000h base + 2D8h offset = 4001_F2D8h
- FMC_DATAW3S4U is 4001_F000h base + 2E0h offset = 4001_F2E0h
- FMC_DATAW3S5U is 4001_F000h base + 2E8h offset = 4001_F2E8h
- FMC_DATAW3S6U is 4001_F000h base + 2F0h offset = 4001_F2F0h
- FMC_DATAW3S7U is 4001_F000h base + 2F8h offset = 4001_F2F8h

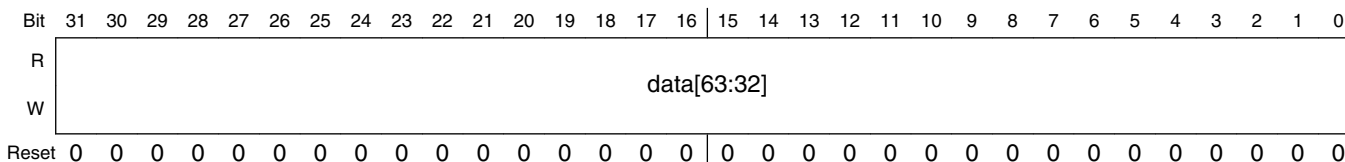

FMC_DATAW3SnU field descriptions

Field	Description
31-0 data[63:32]	Bits [63:32] of data entry

27.4.15 Cache Data Storage (lower word) (FMC_DATAW3SL)

The cache of 64-bit entries is a 4-way, set-associative cache with 8 sets. The ways are numbered 0-3 and the sets are numbered 0-7. In DATAW_xS_yU and DATAW_xS_yL, x denotes the way, y denotes the set, and U and L represent upper and lower word, respectively. This section represents data for the lower word (bits [31:0]) of all 8 sets (n=0-7) in way 3.

Addresses: FMC_DATAW3S0L is 4001_F000h base + 2C4h offset = 4001_F2C4h
 FMC_DATAW3S1L is 4001_F000h base + 2CCh offset = 4001_F2CCh
 FMC_DATAW3S2L is 4001_F000h base + 2D4h offset = 4001_F2D4h
 FMC_DATAW3S3L is 4001_F000h base + 2DCh offset = 4001_F2DCh
 FMC_DATAW3S4L is 4001_F000h base + 2E4h offset = 4001_F2E4h
 FMC_DATAW3S5L is 4001_F000h base + 2ECh offset = 4001_F2ECh
 FMC_DATAW3S6L is 4001_F000h base + 2F4h offset = 4001_F2F4h
 FMC_DATAW3S7L is 4001_F000h base + 2FCh offset = 4001_F2FCh

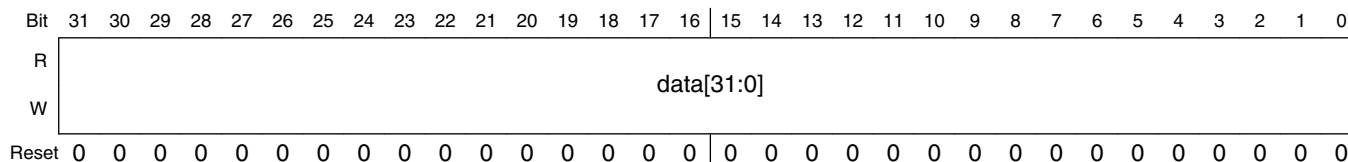

FMC_DATAW3S_nL field descriptions

Field	Description
31–0 data[31:0]	Bits [31:0] of data entry

27.5 Functional description

The FMC is a flash acceleration unit with flexible buffers for user configuration. Besides managing the interface between the device and the flash memory, the FMC can be used to restrict access from crossbar switch masters and customize the cache and buffers to provide single-cycle system-clock data-access times. Whenever a hit occurs for the prefetch speculation buffer, the cache, or the single-entry buffer, the requested data is transferred within a single system clock.

Upon system reset, the FMC is configured to provide a significant level of buffering for transfers from the flash memory:

- Crossbar masters 0, 1, 2 have read access to bank 0 and bank 1.
- For bank 0 and bank 1:
 - Prefetch support for data and instructions is enabled for crossbar masters 0, 1, 2.

- The cache is configured for least recently used (LRU) replacement for all four ways.
- The cache is configured for data or instruction replacement.
- The single-entry buffer is enabled.

Though the default configuration provides a high degree of flash acceleration, advanced users may desire to customize the FMC buffer configurations to maximize throughput for their use cases. When reconfiguring the FMC for custom use cases, do not program the FMC's control registers while the flash memory is being accessed. Instead, change the control registers with a routine executing from RAM in supervisor mode.

The FMC's cache and buffering controls within PFB0CR and PFB1CR allow the tuning of resources to suit particular applications' needs. The cache and two buffers are each controlled individually. The register controls enable buffering and prefetching per memory bank and access type (instruction fetch or data reference). The cache also supports three types of LRU replacement algorithms:

- LRU per set across all four ways,
- LRU with ways [0-1] for instruction fetches and ways [2-3] for data fetches, and
- LRU with ways [0-2] for instruction fetches and way [3] for data fetches.

As an application example: if both instruction fetches and data references are accessing bank 0, control is available to send instruction fetches, data references, or both to the cache or the single-entry buffer. Likewise, speculation can be enabled or disabled for either type of access. If both instruction fetches and data references are cached, the cache's way resources may be divided in several ways between the instruction fetches and data references.

In another application example, the cache can be configured for replacement from bank 0, while the single-entry buffer can be enabled for bank 1 only. This configuration is ideal for applications that use bank 0 for program space and bank 1 for data space.

Chapter 28

Flash Memory Module (FTFL)

28.1 Introduction

NOTE

For the chip-specific implementation details of this module's instances see the chip configuration chapter.

The FTFL module includes the following accessible memory regions:

- Program flash memory for vector space and code store
- Programming acceleration RAM to speed flash programming

Flash memory is ideal for single-supply applications, permitting in-the-field erase and reprogramming operations without the need for any external high voltage power sources.

The FTFL module includes a memory controller that executes commands to modify flash memory contents. An erased bit reads '1' and a programmed bit reads '0'. The programming operation is unidirectional; it can only move bits from the '1' state (erased) to the '0' state (programmed). Only the erase operation restores bits from '0' to '1'; bits cannot be programmed from a '0' to a '1'.

CAUTION

A flash memory location must be in the erased state before being programmed. Cumulative programming of bits (back-to-back program operations without an intervening erase) within a flash memory location is not allowed. Re-programming of existing 0s to 0 is not allowed as this overstresses the device.

The standard shipping condition for flash memory is erased with security disabled. Data loss over time may occur due to degradation of the erased ('1') states and/or programmed ('0')

states. Therefore, it is recommended that each flash block or sector be re-erased immediately prior to factory programming to ensure that the full data retention capability is achieved.

28.1.1 Features

The FTFL module includes the following features.

NOTE

See the device's Chip Configuration details for the exact amount of flash memory available on your device.

28.1.1.1 Program Flash Memory Features

- Sector size of 2 Kbytes
- Program flash protection scheme prevents accidental program or erase of stored data
- Automated, built-in, program and erase algorithms with verify
- Section programming for faster bulk programming times
- Read access to one logical program flash block is possible while programming or erasing data in the other logical program flash block

28.1.1.2 Program Acceleration RAM Features

- RAM to support section programming

28.1.1.3 Other FTFL Module Features

- Internal high-voltage supply generator for flash memory program and erase operations
- Optional interrupt generation upon flash command completion
- Supports MCU security mechanisms which prevent unauthorized access to the flash memory contents

28.1.2 Block Diagram

The block diagram of the FTFL module is shown in the following figure.

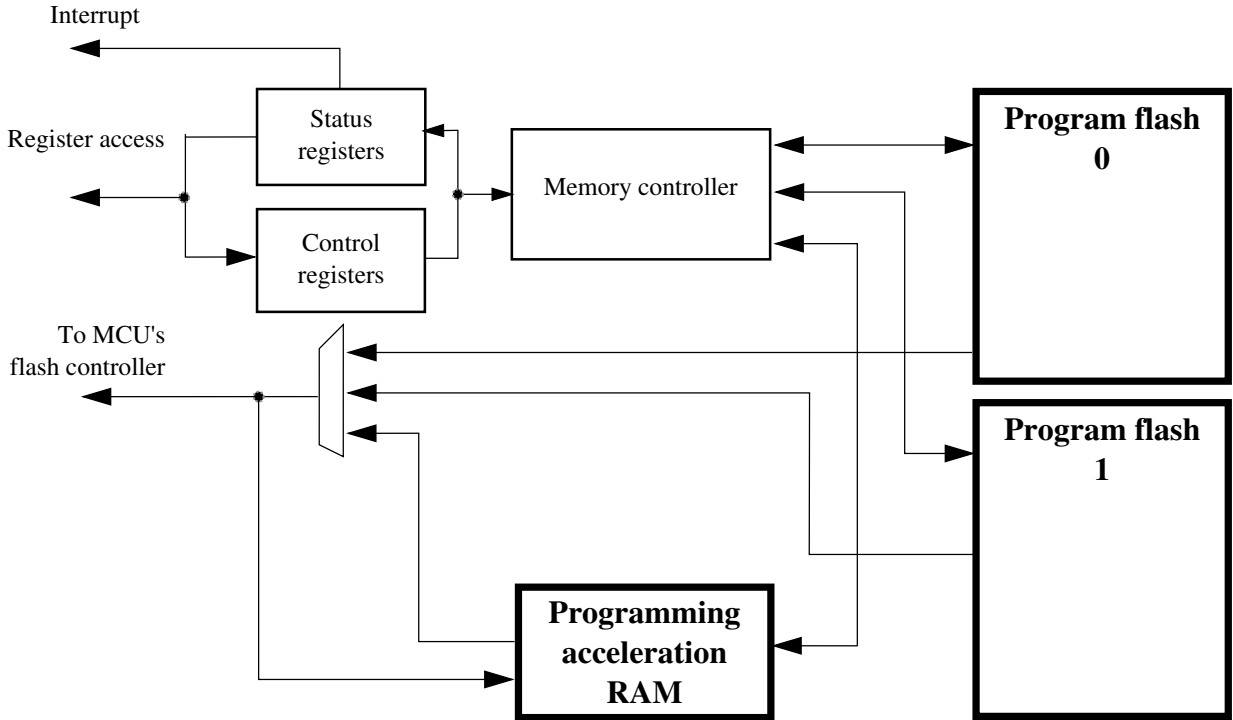

Figure 28-1. FTFL Block Diagram

28.1.3 Glossary

Command write sequence — A series of MCU writes to the Flash FCCOB register group that initiates and controls the execution of Flash algorithms that are built into the FTFL module.

Endurance — The number of times that a flash memory location can be erased and reprogrammed.

FCCOB (Flash Common Command Object) — A group of flash registers that are used to pass command, address, data, and any associated parameters to the memory controller in the FTFL module.

Flash block — A macro within the FTFL module which provides the nonvolatile memory storage.

FTFL Module — All flash blocks plus a flash management unit providing high-level control and an interface to MCU buses.

IFR — Nonvolatile information register found in each flash block, separate from the main memory array.

NVM — Nonvolatile memory. A memory technology that maintains stored data during power-off. The flash array is an NVM using NOR-type flash memory technology.

NVM Normal Mode — An NVM mode that provides basic user access to FTFL resources. The CPU or other bus masters initiate flash program and erase operations (or other FTFL commands) using writes to the FCCOB register group in the FTFL module.

NVM Special Mode — An NVM mode enabling external, off-chip access to the memory resources in the FTFL module. A reduced FTFL command set is available when the MCU is secured. See the Chip Configuration details for information on when this mode is used.

Phrase — 64 bits of data with an aligned phrase having byte-address[2:0] = 000.

Longword — 32 bits of data with an aligned longword having byte-address[1:0] = 00.

Word — 16 bits of data with an aligned word having byte-address[0] = 0.

Program flash — The program flash memory provides nonvolatile storage for vectors and code store.

Program flash Sector — The smallest portion of the program flash memory (consecutive addresses) that can be erased.

Retention — The length of time that data can be kept in the NVM without experiencing errors upon readout. Since erased (1) states are subject to degradation just like programmed (0) states, the data retention limit may be reached from the last erase operation (not from the programming time).

RWW— Read-While-Write. The ability to simultaneously read from one memory resource while commanded operations are active in another memory resource.

Section Program Buffer — Lower half of the programming acceleration RAM allocated for storing large amounts of data for programming via the Program Section command.

Secure — An MCU state conveyed to the FTFL module as described in the Chip Configuration details for this device. In the secure state, reading and changing NVM contents is restricted.

28.2 External Signal Description

The FTFL module contains no signals that connect off-chip.

28.3 Memory Map and Registers

This section describes the memory map and registers for the FTFL module. Data read from unimplemented memory space in the FTFL module is undefined. Writes to unimplemented or reserved memory space (registers) in the FTFL module are ignored.

28.3.1 Flash Configuration Field Description

The program flash memory contains a 16-byte flash configuration field that stores default protection settings (loaded on reset) and security information that allows the MCU to restrict access to the FTFL module.

Flash Configuration Field Byte Address	Size (Bytes)	Field Description
0x0_0400 - 0x0_0407	8	Backdoor Comparison Key. Refer to Verify Backdoor Access Key Command and Unsecuring the Chip Using Backdoor Key Access .
0x0_0408 - 0x0_040B	4	Program flash protection bytes. Refer to the description of the Program Flash Protection Registers (FPROT0-3).
0x0_040F	1	Program flash only devices: Reserved
0x0_040E	1	Program flash only devices: Reserved
0x0_040D	1	Flash nonvolatile option byte. Refer to the description of the Flash Option Register (FOPT).
0x0_040C	1	Flash security byte. Refer to the description of the Flash Security Register (FSEC).

28.3.2 Program Flash IFR Map

The program flash IFR is nonvolatile information memory that can be read freely, but the user has no erase and limited program capabilities (see the Read Once, Program Once, and Read Resource commands in [Read Once Command](#), [Program Once Command](#) and [Read Resource Command](#)). The contents of the program flash IFR are summarized in the following table and further described in the subsequent paragraphs.

For devices that only contain program flash, the program flash IFR is located within the program flash 0 memory block.

Address Range	Size (Bytes)	Field Description
0x00 – 0xBF	192	Reserved
0xC0 – 0xFF	64	Program Once Field

28.3.2.1 Program Once Field

The Program Once Field in the program flash IFR provides 64 bytes of user data storage separate from the program flash main array. The user can program the Program Once Field one time only as there is no program flash IFR erase mechanism available to the user. The Program Once Field can be read any number of times. This section of the program flash IFR is accessed in 4-Byte records using the Read Once and Program Once commands (see [Read Once Command](#) and [Program Once Command](#)).

28.3.3 Register Descriptions

The FTFM module contains a set of memory-mapped control and status registers.

NOTE

While a command is running (FSTAT[CCIF]=0), register writes are not accepted to any register except FCNFG and FSTAT. The no-write rule is relaxed during the start-up reset sequence, prior to the initial rise of CCIF. During this initialization period the user may write any register. All register writes are also disabled (except for registers FCNFG and FSTAT) whenever an erase suspend request is active (FCNFG[ERSSUSP]=1).

FTFL memory map

Absolute address (hex)	Register name	Width (in bits)	Access	Reset value	Section/page
4002_0000	Flash Status Register (FTFL_FSTAT)	8	R/W	00h	28.33.1/605
4002_0001	Flash Configuration Register (FTFL_FCNFG)	8	R/W	00h	28.33.2/607
4002_0002	Flash Security Register (FTFL_FSEC)	8	R	Undefined	28.33.3/608
4002_0003	Flash Option Register (FTFL_FOPT)	8	R	Undefined	28.33.4/610

Table continues on the next page...

FTFL memory map (continued)

Absolute address (hex)	Register name	Width (in bits)	Access	Reset value	Section/page
4002_0004	Flash Common Command Object Registers (FTFL_FCCOB3)	8	R/W	00h	28.33.5/611
4002_0005	Flash Common Command Object Registers (FTFL_FCCOB2)	8	R/W	00h	28.33.5/611
4002_0006	Flash Common Command Object Registers (FTFL_FCCOB1)	8	R/W	00h	28.33.5/611
4002_0007	Flash Common Command Object Registers (FTFL_FCCOB0)	8	R/W	00h	28.33.5/611
4002_0008	Flash Common Command Object Registers (FTFL_FCCOB7)	8	R/W	00h	28.33.5/611
4002_0009	Flash Common Command Object Registers (FTFL_FCCOB6)	8	R/W	00h	28.33.5/611
4002_000A	Flash Common Command Object Registers (FTFL_FCCOB5)	8	R/W	00h	28.33.5/611
4002_000B	Flash Common Command Object Registers (FTFL_FCCOB4)	8	R/W	00h	28.33.5/611
4002_000C	Flash Common Command Object Registers (FTFL_FCCOBB)	8	R/W	00h	28.33.5/611
4002_000D	Flash Common Command Object Registers (FTFL_FCCOBA)	8	R/W	00h	28.33.5/611
4002_000E	Flash Common Command Object Registers (FTFL_FCCOB9)	8	R/W	00h	28.33.5/611
4002_000F	Flash Common Command Object Registers (FTFL_FCCOB8)	8	R/W	00h	28.33.5/611
4002_0010	Program Flash Protection Registers (FTFL_FPROT3)	8	R/W	Undefined	28.33.6/612
4002_0011	Program Flash Protection Registers (FTFL_FPROT2)	8	R/W	Undefined	28.33.6/612
4002_0012	Program Flash Protection Registers (FTFL_FPROT1)	8	R/W	Undefined	28.33.6/612
4002_0013	Program Flash Protection Registers (FTFL_FPROT0)	8	R/W	Undefined	28.33.6/612

28.33.1 Flash Status Register (FTFL_FSTAT)

The FSTAT register reports the operational status of the FTFL module.

The CCIF, RDCOLERR, ACCERR, and FPVIOL bits are readable and writable. The MGSTAT0 bit is read only. The unassigned bits read 0 and are not writable.

NOTE

When set, the Access Error (ACCERR) and Flash Protection Violation (FPVIOL) bits in this register prevent the launch of any more commands until the flag is cleared (by writing a one to it).

Address: FTFLL_FSTAT is 4002_0000h base + 0h offset = 4002_0000h

Bit	7	6	5	4	3	2	1	0
Read	CCIF	RDCOLERR	ACCERR	FPVIOL	0			MGSTAT0
Write	w1c	w1c	w1c	w1c				
Reset	0	0	0	0	0	0	0	0

FTFL_FSTAT field descriptions

Field	Description
7 CCIF	<p>Command Complete Interrupt Flag</p> <p>The CCIF flag indicates that a FTFLL command has completed. The CCIF flag is cleared by writing a 1 to CCIF to launch a command, and CCIF stays low until command completion or command violation.</p> <p>The CCIF bit is reset to 0 but is set to 1 by the memory controller at the end of the reset initialization sequence. Depending on how quickly the read occurs after reset release, the user may or may not see the 0 hardware reset value.</p> <p>0 FTFLL command in progress 1 FTFLL command has completed</p>
6 RDCOLERR	<p>FTFL Read Collision Error Flag</p> <p>The RDCOLERR error bit indicates that the MCU attempted a read from an FTFLL resource that was being manipulated by an FTFLL command (CCIF=0). Any simultaneous access is detected as a collision error by the block arbitration logic. The read data in this case cannot be guaranteed. The RDCOLERR bit is cleared by writing a 1 to it. Writing a 0 to RDCOLERR has no effect.</p> <p>0 No collision error detected 1 Collision error detected</p>
5 ACCERR	<p>Flash Access Error Flag</p> <p>The ACCERR error bit indicates an illegal access has occurred to an FTFLL resource caused by a violation of the command write sequence or issuing an illegal FTFLL command. While ACCERR is set, the CCIF flag cannot be cleared to launch a command. The ACCERR bit is cleared by writing a 1 to it. Writing a 0 to the ACCERR bit has no effect.</p> <p>0 No access error detected 1 Access error detected</p>
4 FPVIOL	<p>Flash Protection Violation Flag</p> <p>The FPVIOL error bit indicates an attempt was made to program or erase an address in a protected area of program flash memory during a command write sequence. While FPVIOL is set, the CCIF flag cannot be cleared to launch a command. The FPVIOL bit is cleared by writing a 1 to it. Writing a 0 to the FPVIOL bit has no effect.</p> <p>0 No protection violation detected 1 Protection violation detected</p>

Table continues on the next page...

FTFL_FSTAT field descriptions (continued)

Field	Description
3-1 Reserved	This read-only field is reserved and always has the value zero.
0 MGSTAT0	<p>Memory Controller Command Completion Status Flag</p> <p>The MGSTAT0 status flag is set if an error is detected during execution of an FTFL command or during the flash reset sequence. As a status flag, this bit cannot (and need not) be cleared by the user like the other error flags in this register.</p> <p>The value of the MGSTAT0 bit for "command-N" is valid only at the end of the "command-N" execution when CCIF=1 and before the next command has been launched. At some point during the execution of "command-N+1," the previous result is discarded and any previous error is cleared.</p>

28.33.2 Flash Configuration Register (FTFL_FCNFG)

This register provides information on the current functional state of the FTFL module.

The erase control bits (ERSAREQ and ERSSUSP) have write restrictions. SWAP, PFLSH, RAMRDY are read-only status bits. The unassigned bits read as noted and are not writable. The reset values for the SWAP, PFLSH, RAMRDY bits are determined during the reset sequence.

Address: FTFL_FCNFG is 4002_0000h base + 1h offset = 4002_0001h

Bit	7	6	5	4	3	2	1	0
Read	CCIE	RDCOLLIE	ERSAREQ	ERSSUSP	SWAP	PFLSH	RAMRDY	EEERDY
Write								
Reset	0	0	0	0	0	0	0	0

FTFL_FCNFG field descriptions

Field	Description
7 CCIE	<p>Command Complete Interrupt Enable</p> <p>The CCIE bit controls interrupt generation when an FTFL command completes.</p> <p>0 Command complete interrupt disabled 1 Command complete interrupt enabled. An interrupt request is generated whenever the FSTAT[CCIF] flag is set.</p>
6 RDCOLLIE	<p>Read Collision Error Interrupt Enable</p> <p>The RDCOLLIE bit controls interrupt generation when an FTFL read collision error occurs.</p> <p>0 Read collision error interrupt disabled 1 Read collision error interrupt enabled. An interrupt request is generated whenever an FTFL read collision error is detected (see the description of FSTAT[RDCOLERR]).</p>
5 ERSAREQ	Erase All Request

Table continues on the next page...

FTFL_FCENFG field descriptions (continued)

Field	Description
	<p>This bit issues a request to the memory controller to execute the Erase All Blocks command and release security. ERSAREQ is not directly writable but is under indirect user control. Refer to the device's Chip Configuration details on how to request this command.</p> <p>The ERSAREQ bit sets when an erase all request is triggered external to the FTFL and CCIF is set (no command is currently being executed). ERSAREQ is cleared by the FTFL when the operation completes.</p> <p>0 No request or request complete 1 Request to: <ol style="list-style-type: none"> 1. run the Erase All Blocks command, 2. verify the erased state, 3. program the security byte in the Flash Configuration Field to the unsecure state, and 4. release MCU security by setting the FSEC[SEC] field to the unsecure state. </p>
4 ERSSUSP	<p>Erase Suspend</p> <p>The ERSSUSP bit allows the user to suspend (interrupt) the Erase Flash Sector command while it is executing.</p> <p>0 No suspend requested 1 Suspend the current Erase Flash Sector command execution.</p>
3 SWAP	<p>Swap</p> <p>For program flash only configurations, the SWAP flag indicates which physical program flash block is located at relative address 0x0000. The state of the SWAP flag is set by the FTFL during the reset sequence . See the Swap Control command section for information on swap management.</p> <p>0 Physical program flash 0 is located at relative address 0x0000 1 If the PFLSH flag is set, physical program flash 1 is located at relative address 0x0000. If the PFLSH flag is not set, physical program flash 0 is located at relative address 0x0000</p>
2 PFLSH	<p>FTFL configuration</p> <p>0 Reserved 1 FTFL configured for program flash only, without support for data flash and/or EEPROM</p>
1 RAMRDY	<p>RAM Ready</p> <p>This flag indicates the current status of the programming acceleration RAM .</p> <p>This bit should always be set.</p> <p>0 Programming acceleration RAM is not available. 1 Programming acceleration RAM is available.</p>
0 EEERDY	<p>This field is reserved.</p> <p>0 1</p>

28.33.3 Flash Security Register (FTFL_FSEC)

This read-only register holds all bits associated with the security of the MCU and FTFL module.

During the reset sequence, the register is loaded with the contents of the flash security byte in the Flash Configuration Field located in program flash memory. The Flash basis for the values is signified by X in the reset value.

Address: FTFL_FSEC is 4002_0000h base + 2h offset = 4002_0002h

Bit	7	6	5	4	3	2	1	0
Read	KEYEN		MEEN		FSLACC		SEC	
Write								
Reset	x*	x*	x*	x*	x*	x*	x*	x*

- * Notes:
- x = Undefined at reset.

FTFL_FSEC field descriptions

Field	Description
7-6 KEYEN	<p>Backdoor Key Security Enable</p> <p>These bits enable and disable backdoor key access to the FTFL module.</p> <p>00 Backdoor key access disabled 01 Backdoor key access disabled (preferred KEYEN state to disable backdoor key access) 10 Backdoor key access enabled 11 Backdoor key access disabled</p>
5-4 MEEN	<p>Mass Erase Enable Bits</p> <p>Enables and disables mass erase capability of the FTFL module. The state of the MEEN bits is only relevant when the SEC bits are set to secure outside of NVM Normal Mode. When the SEC field is set to unsecure, the MEEN setting does not matter.</p> <p>00 Mass erase is enabled 01 Mass erase is enabled 10 Mass erase is disabled 11 Mass erase is enabled</p>
3-2 FSLACC	<p>Freescale Failure Analysis Access Code</p> <p>These bits enable or disable access to the flash memory contents during returned part failure analysis at Freescale. When SEC is secure and FSLACC is denied, access to the program flash contents is denied and any failure analysis performed by Freescale factory test must begin with a full erase to unsecure the part.</p> <p>When access is granted (SEC is unsecure, or SEC is secure and FSLACC is granted), Freescale factory testing has visibility of the current flash contents. The state of the FSLACC bits is only relevant when the SEC bits are set to secure. When the SEC field is set to unsecure, the FSLACC setting does not matter.</p> <p>00 Freescale factory access granted 01 Freescale factory access denied 10 Freescale factory access denied 11 Freescale factory access granted</p>
1-0 SEC	Flash Security

Table continues on the next page...

FTFL_FSEC field descriptions (continued)

Field	Description
	These bits define the security state of the MCU. In the secure state, the MCU limits access to FTFL module resources. The limitations are defined per device and are detailed in the Chip Configuration details. If the FTFL module is unsecured using backdoor key access, the SEC bits are forced to 10b.
00	MCU security status is secure
01	MCU security status is secure
10	MCU security status is unsecure (The standard shipping condition of the FTFL is unsecure.)
11	MCU security status is secure

28.33.4 Flash Option Register (FTFL_FOPT)

The flash option register allows the MCU to customize its operations by examining the state of these read-only bits, which are loaded from NVM at reset. The function of the bits is defined in the device's Chip Configuration details.

All bits in the register are read-only .

During the reset sequence, the register is loaded from the flash nonvolatile option byte in the Flash Configuration Field located in program flash memory. The flash basis for the values is signified by X in the reset value.

Address: FTFL_FOPT is 4002_0000h base + 3h offset = 4002_0003h

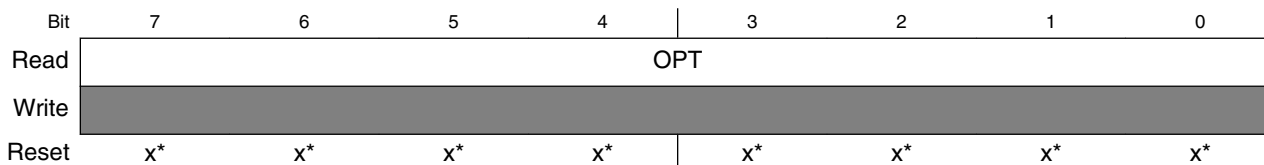

* Notes:

- x = Undefined at reset.

FTFL_FOPT field descriptions

Field	Description
7-0 OPT	Nonvolatile Option These bits are loaded from flash to this register at reset. Refer to the device's Chip Configuration details for the definition and use of these bits.

28.33.5 Flash Common Command Object Registers (FTFL_FCCOBn)

The FCCOB register group provides 12 bytes for command codes and parameters. The individual bytes within the set append a 0-B hex identifier to the FCCOB register name: FCCOB0, FCCOB1, ..., FCCOB11.

Addresses: 4002_0000h base + 4h offset + (1d × n), where n = 0d to 11d

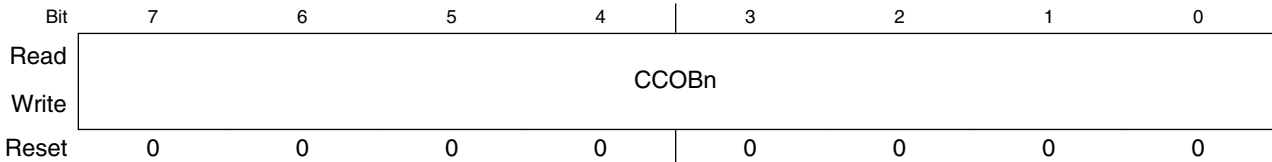

FTFL_FCCOBn field descriptions

Field	Description																						
7-0 CCOBn	<p>The FCCOB register provides a command code and relevant parameters to the memory controller. The individual registers that compose the FCCOB data set can be written in any order, but you must provide all needed values, which vary from command to command. First, set up all required FCCOB fields and then initiate the command's execution by writing a 1 to the FSTAT[CCIF] bit. This clears the CCIF bit, which locks all FCCOB parameter fields and they cannot be changed by the user until the command completes (CCIF returns to 1). No command buffering or queueing is provided; the next command can be loaded only after the current command completes.</p> <p>Some commands return information to the FCCOB registers. Any values returned to FCCOB are available for reading after the FSTAT[CCIF] flag returns to 1 by the memory controller.</p> <p>The following table shows a generic FTFL command format. The first FCCOB register, FCCOB0, always contains the command code. This 8-bit value defines the command to be executed. The command code is followed by the parameters required for this specific FTFL command, typically an address and/or data values.</p> <p>NOTE: The command parameter table is written in terms of FCCOB Number (which is equivalent to the byte number). This number is a reference to the FCCOB register name and is not the register address.</p> <table border="1" style="width: 100%; border-collapse: collapse;"> <thead> <tr> <th style="width: 20%;">FCCOB Number</th> <th style="width: 80%;">Typical Command Parameter Contents [7:0]</th> </tr> </thead> <tbody> <tr> <td>0</td> <td>FCMD (a code that defines the FTFL command)</td> </tr> <tr> <td>1</td> <td>Flash address [23:16]</td> </tr> <tr> <td>2</td> <td>Flash address [15:8]</td> </tr> <tr> <td>3</td> <td>Flash address [7:0]</td> </tr> <tr> <td>4</td> <td>Data Byte 0</td> </tr> <tr> <td>5</td> <td>Data Byte 1</td> </tr> <tr> <td>6</td> <td>Data Byte 2</td> </tr> <tr> <td>7</td> <td>Data Byte 3</td> </tr> <tr> <td>8</td> <td>Data Byte 4</td> </tr> <tr> <td>9</td> <td>Data Byte 5</td> </tr> </tbody> </table>	FCCOB Number	Typical Command Parameter Contents [7:0]	0	FCMD (a code that defines the FTFL command)	1	Flash address [23:16]	2	Flash address [15:8]	3	Flash address [7:0]	4	Data Byte 0	5	Data Byte 1	6	Data Byte 2	7	Data Byte 3	8	Data Byte 4	9	Data Byte 5
FCCOB Number	Typical Command Parameter Contents [7:0]																						
0	FCMD (a code that defines the FTFL command)																						
1	Flash address [23:16]																						
2	Flash address [15:8]																						
3	Flash address [7:0]																						
4	Data Byte 0																						
5	Data Byte 1																						
6	Data Byte 2																						
7	Data Byte 3																						
8	Data Byte 4																						
9	Data Byte 5																						

FTFL_FCCOB n field descriptions (continued)

Field	Description	
	FCCOB Number	Typical Command Parameter Contents [7:0]
	A	Data Byte 6
	B	Data Byte 7
	<p>FCCOB Endianness and Multi-Byte Access :</p> <p>The FCCOB register group uses a big endian addressing convention. For all command parameter fields larger than 1 byte, the most significant data resides in the lowest FCCOB register number. The FCCOB register group may be read and written as individual bytes, aligned words (2 bytes) or aligned longwords (4 bytes).</p>	

28.33.6 Program Flash Protection Registers (FTFL_FPROT n)

The FPROT registers define which logical program flash regions are protected from program and erase operations. Protected flash regions cannot have their content changed; that is, these regions cannot be programmed and cannot be erased by any FTFL command. Unprotected regions can be changed by program and erase operations.

The four FPROT registers allow 32 protectable regions. Each bit protects a 1/32 region of the program flash memory. The bitfields are defined in each register as follows:

Program flash protection register	Program flash protection bits
FPROT0	PROT[31:24]
FPROT1	PROT[23:16]
FPROT2	PROT[15:8]
FPROT3	PROT[7:0]

During the reset sequence, the FPROT registers are loaded with the contents of the program flash protection bytes in the Flash Configuration Field as indicated in the following table.

Program flash protection register	Flash Configuration Field offset address
FPROT0	0x0008
FPROT1	0x0009
FPROT2	0x000A
FPROT3	0x000B

To change the program flash protection that is loaded during the reset sequence, unprotect the sector of program flash memory that contains the Flash Configuration Field. Then, reprogram the program flash protection byte.

Addresses: FTFL_FPROT3 is 4002_0000h base + 10h offset = 4002_0010h
 FTFL_FPROT2 is 4002_0000h base + 11h offset = 4002_0011h
 FTFL_FPROT1 is 4002_0000h base + 12h offset = 4002_0012h
 FTFL_FPROT0 is 4002_0000h base + 13h offset = 4002_0013h

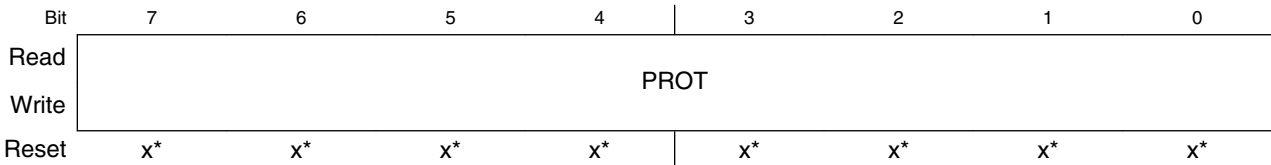

- * Notes:
- x = Undefined at reset.

FTFL_FPROTn field descriptions

Field	Description
7-0 PROT	<p>Program Flash Region Protect</p> <p>Each program flash region can be protected from program and erase operations by setting the associated PROT bit.</p> <p>In NVM Normal mode: The protection can only be increased, meaning that currently unprotected memory can be protected, but currently protected memory cannot be unprotected. Since unprotected regions are marked with a 1 and protected regions use a 0, only writes changing 1s to 0s are accepted. This 1-to-0 transition check is performed on a bit-by-bit basis. Those FPROT bits with 1-to-0 transitions are accepted while all bits with 0-to-1 transitions are ignored .</p> <p>In NVM Special mode: All bits of FPROT are writable without restriction. Unprotected areas can be protected and protected areas can be unprotected.</p> <p>Restriction: The user must never write to any FPROT register while a command is running (CCIF=0). Trying to alter data in any protected area in the program flash memory results in a protection violation error and sets the FSTAT[FPVIOL] bit. A full block erase of a program flash block is not possible if it contains any protected region.</p> <p>Each bit in the 32-bit protection register represents 1/32 of the total program flash .</p> <p>0 Program flash region is protected. 1 Program flash region is not protected</p>

28.4 Functional Description

The following sections describe functional details of the FTFL module.

28.4.1 Program Flash Memory Swap

For devices that only contain program flash memory: The user can configure the logical memory map of the program flash space such that either of the two physical program flash blocks can exist at relative address 0x0000. This swap feature enables the lower half of the logical program flash space to be operational while the upper half is being updated for future use.

The Swap Control command handles swapping the two logical P-Flash memory blocks within the memory map. See [Swap Control Command](#) for details.

28.4.2 Interrupts

The FTFM module can generate interrupt requests to the MCU upon the occurrence of various FTFM events. These interrupt events and their associated status and control bits are shown in the following table.

Table 28-24. FTFM Interrupt Sources

FTFM Event	Readable Status Bit	Interrupt Enable Bit
FTFM Command Complete	FSTAT[CCIF]	FCNFG[CCIE]
FTFM Read Collision Error	FSTAT[RDCOLERR]	FCNFG[RDCOLLIE]

Note

Vector addresses and their relative interrupt priority are determined at the MCU level.

28.4.3 Flash Operation in Low-Power Modes

28.4.3.1 Wait Mode

When the MCU enters wait mode, the FTFM module is not affected. The FTFM module can recover the MCU from wait via the command complete interrupt (see [Interrupts](#)).

28.4.3.2 Stop Mode

When the MCU requests stop mode, if an FTFM command is active (CCIF = 0) the command execution completes before the MCU is allowed to enter stop mode.

CAUTION

The MCU should never enter stop mode while any FTFL command is running (CCIF = 0).

NOTE

While the MCU is in very-low-power modes (VLPR, VLPW, VLPS), the FTFL module does not accept flash commands.

28.4.4 Functional Modes of Operation

The FTFL module has two operating modes: NVM Normal and NVM Special. The operating mode affects the command set availability (see [Table 28-25](#)). Refer to the Chip Configuration details of this device for how to activate each mode.

28.4.5 Flash Reads and Ignored Writes

The FTFL module requires only the flash address to execute a flash memory read. MCU read access is available to all flash blocks.

The MCU must not read from the flash memory while commands are running (as evidenced by CCIF=0) on that block. Read data cannot be guaranteed from a flash block while any command is processing within that block. The block arbitration logic detects any simultaneous access and reports this as a read collision error (see the FSTAT[RDCOLERR] bit).

28.4.6 Read While Write (RWW)

The following simultaneous accesses are allowed:

- The user may read from one logical program flash memory space while commands (typically program and erase operations) are active in the other logical program flash memory space.

Simultaneous operations are further discussed in [Allowed Simultaneous Flash Operations](#).

28.4.7 Flash Program and Erase

All flash functions except read require the user to setup and launch an FTL command through a series of peripheral bus writes. The user cannot initiate any further FTL commands until notified that the current command has completed. The FTL command structure and operation are detailed in [FTL Command Operations](#).

28.4.8 FTL Command Operations

FTL command operations are typically used to modify flash memory contents. The next sections describe:

- The command write sequence used to set FTL command parameters and launch execution
- A description of all FTL commands available

28.4.8.1 Command Write Sequence

FTL commands are specified using a command write sequence illustrated in [Figure 28-24](#). The FTL module performs various checks on the command (FCCOB) content and continues with command execution if all requirements are fulfilled.

Before launching a command, the ACCERR and FPVIOL bits in the FSTAT register must be zero and the CCIF flag must read 1 to verify that any previous command has completed. If CCIF is zero, the previous command execution is still active, a new command write sequence cannot be started, and all writes to the FCCOB registers are ignored.

28.4.8.1.1 Load the FCCOB Registers

The user must load the FCCOB registers with all parameters required by the desired FTL command. The individual registers that make up the FCCOB data set can be written in any order.

28.4.8.1.2 Launch the Command by Clearing CCIF

Once all relevant command parameters have been loaded, the user launches the command by clearing the FSTAT[CCIF] bit by writing a '1' to it. The CCIF flag remains zero until the FTL command completes.

The FSTAT register contains a blocking mechanism, which prevents a new command from launching (can't clear CCIF) if the previous command resulted in an access error (FSTAT[ACCERR]=1) or a protection violation (FSTAT[FPVIOL]=1). In error scenarios, two writes to FSTAT are required to initiate the next command: the first write clears the error flags, the second write clears CCIF.

28.4.8.1.3 Command Execution and Error Reporting

The command processing has several steps:

1. The FTFL reads the command code and performs a series of parameter checks and protection checks, if applicable, which are unique to each command.

If the parameter check fails, the FSTAT[ACCERR] (access error) flag is set. ACCERR reports invalid instruction codes and out-of bounds addresses. Usually, access errors suggest that the command was not set-up with valid parameters in the FCCOB register group.

Program and erase commands also check the address to determine if the operation is requested to execute on protected areas. If the protection check fails, the FSTAT[FPVIOL] (protection error) flag is set.

Command processing never proceeds to execution when the parameter or protection step fails. Instead, command processing is terminated after setting the FSTAT[CCIF] bit.

2. If the parameter and protection checks pass, the command proceeds to execution. Run-time errors, such as failure to erase verify, may occur during the execution phase. Run-time errors are reported in the FSTAT[MGSTAT0] bit. A command may have access errors, protection errors, and run-time errors, but the run-time errors are not seen until all access and protection errors have been corrected.
3. Command execution results, if applicable, are reported back to the user via the FCCOB and FSTAT registers.
4. The FTFL sets the FSTAT[CCIF] bit signifying that the command has completed.

The flow for a generic command write sequence is illustrated in the following figure.

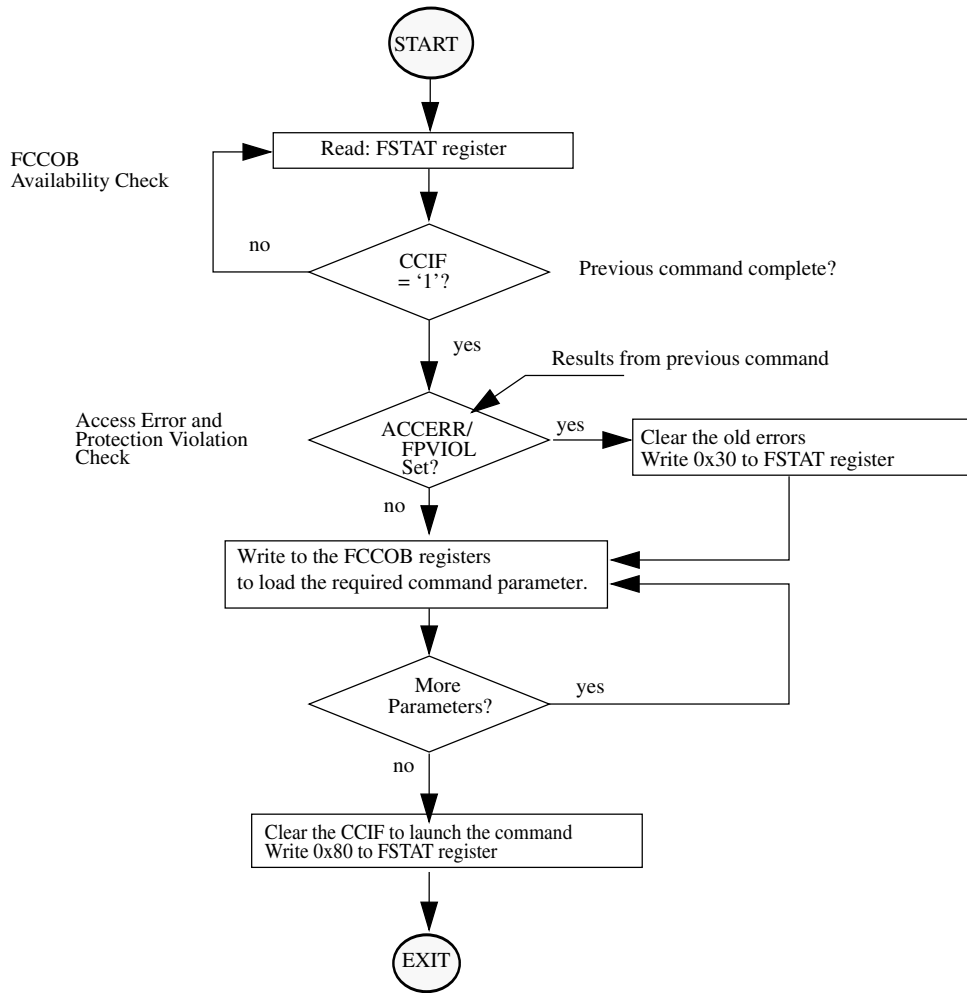

Figure 28-24. Generic FTFL Command Write Sequence Flowchart

28.4.8.2 FTFL Commands

The following table summarizes the function of all FTFL commands.

FCMD	Command	Program flash 0	Program flash 1	Function
0x00	Read 1s Block	×	×	Verify that a program flash block is erased.
0x01	Read 1s Section	×	×	Verify that a given number of program flash locations from a starting address are erased.
0x02	Program Check	×	×	Tests previously-programmed locations at margin read levels.

Table continues on the next page...

FCMD	Command	Program flash 0	Program flash 1	Function
0x03	Read Resource	IFR	IFR	Read 4 bytes from program flash IFR or version ID.
0x06	Program Longword	×	×	Program 4 bytes in a program flash block.
0x08	Erase Flash Block	×	×	Erase a program flash block. An erase of any flash block is only possible when unprotected.
0x09	Erase Flash Sector	×	×	Erase all bytes in a program flash sector.
0x0B	Program Section	×	×	Program data from the Section Program Buffer to a program flash block.
0x40	Read 1s All Blocks	×	×	Verify that all program flash blocks are erased then release MCU security.
0x41	Read Once	IFR		Read 4 bytes of a dedicated 64 byte field in the program flash 0 IFR.
0x43	Program Once	IFR		One-time program of 4 bytes of a dedicated 64-byte field in the program flash 0 IFR.
0x44	Erase All Blocks	×	×	Erase all program flash blocks, program flash 1 IFR. Then, verify-erase and release MCU security. NOTE: An erase is only possible when all memory locations are unprotected.
0x45	Verify Backdoor Access Key	×	×	Release MCU security after comparing a set of user-supplied security keys to those stored in the program flash.
0x46	Swap Control	×	×	Handles swap-related activities

28.4.8.3 FTFL Commands by Mode

The following table shows the FTFL commands that can be executed in each flash operating mode.

Table 28-25. FTFL Commands by Mode

FCMD	Command	NVM Normal			NVM Special		
		Unsecure	Secure	MEEN=10	Unsecure	Secure	MEEN=10
0x00	Read 1s Block	x	x	x	x	—	—
0x01	Read 1s Section	x	x	x	x	—	—
0x02	Program Check	x	x	x	x	—	—
0x03	Read Resource	x	x	x	x	—	—
0x06	Program Longword	x	x	x	x	—	—
0x08	Erase Flash Block	x	x	x	x	—	—
0x09	Erase Flash Sector	x	x	x	x	—	—
0x0B	Program Section	x	x	x	x	—	—
0x40	Read 1s All Blocks	x	x	x	x	x	—
0x41	Read Once	x	x	x	x	—	—
0x43	Program Once	x	x	x	x	—	—
0x44	Erase All Blocks	x	x	x	x	x	—
0x45	Verify Backdoor Access Key	x	x	x	x	—	—

28.4.8.4 Allowed Simultaneous Flash Operations

Only the operations marked 'OK' in the following table are permitted to run simultaneously on the program flash memories. Some operations cannot be executed simultaneously because certain hardware resources are shared by the memories.

Table 28-26. Allowed Simultaneous Memory Operations

		Program Flash 0			Program Flash 1		
		Read	Program	Sector Erase	Read	Program	Sector Erase
Program flash 0	Read	—				OK	OK
	Program		—		OK		
	Sector Erase			—	OK		
Program flash 1	Read		OK	OK	—		
	Program	OK				—	
	Sector Erase	OK					—

28.4.9 Margin Read Commands

The Read-1s commands (Read 1s All Blocks, Read 1s Block, and Read 1s Section) and the Program Check command have a margin choice parameter that allows the user to apply non-standard read reference levels to the program flash array reads performed by these commands. Using the preset 'user' and 'factory' margin levels, these commands perform their associated read operations at tighter tolerances than a 'normal' read. These non-standard read levels are applied only during the command execution. All simple (uncommanded) flash array reads to the MCU always use the standard, un-margined, read reference level.

Only the 'normal' read level should be employed during normal flash usage. The non-standard, 'user' and 'factory' margin levels should be employed only in special cases. They can be used during special diagnostic routines to gain confidence that the device is not suffering from the end-of-life data loss customary of flash memory devices.

Erased ('1') and programmed ('0') bit states can degrade due to elapsed time and data cycling (number of times a bit is erased and re-programmed). The lifetime of the erased states is relative to the last erase operation. The lifetime of the programmed states is measured from the last program time.

The 'user' and 'factory' levels become, in effect, a minimum safety margin; i.e. if the reads pass at the tighter tolerances of the 'user' and 'factory' margins, then the 'normal' reads have at least this much safety margin before they experience data loss.

The 'user' margin is a small delta to the normal read reference level. 'User' margin levels can be employed to check that flash memory contents have adequate margin for normal level read operations. If unexpected read results are encountered when checking flash memory contents at the 'user' margin levels, loss of information might soon occur during 'normal' readout.

The 'factory' margin is a bigger deviation from the norm, a more stringent read criteria that should only be attempted immediately (or very soon) after completion of an erase or program command, early in the cycling life. 'Factory' margin levels can be used to check that flash memory contents have adequate margin for long-term data retention at the normal level setting. If unexpected results are encountered when checking flash memory contents at 'factory' margin levels, the flash memory contents should be erased and reprogrammed.

CAUTION

Factory margin levels must only be used during verify of the initial factory programming.

28.4.10 FTFL Command Description

This section describes all FTFL commands that can be launched by a command write sequence. The FTFL sets the FSTAT[ACCERR] bit and aborts the command execution if any of the following illegal conditions occur:

- There is an unrecognized command code in the FCCOB FCMD field.
- There is an error in a FCCOB field for the specific commands. Refer to the error handling table provided for each command.

Ensure that the ACCERR and FPVIOL bits in the FSTAT register are cleared prior to starting the command write sequence. As described in [Launch the Command by Clearing CCIF](#), a new command cannot be launched while these error flags are set.

Do not attempt to read a flash block while the FTFL is running a command (CCIF = 0) on that same block. The FTFL may return invalid data to the MCU with the collision error flag (FSTAT[RDCOLERR]) set.

When required by the command, address bit 23 selects between:

- program flash 0 (=0) block
- program flash 1 (=1) block

CAUTION

Flash data must be in the erased state before being programmed. Cumulative programming of bits (adding more zeros) is not allowed.

28.4.10.1 Read 1s Block Command

The Read 1s Block command checks to see if an entire program flash block has been erased to the specified margin level. The FCCOB flash address bits determine which logical block is erase-verified.

Table 28-27. Read 1s Block Command FCCOB Requirements

FCCOB Number	FCCOB Contents [7:0]
0	0x00 (RD1BLK)
1	Flash address [23:16] in the flash block to be verified
2	Flash address [15:8] in the flash block to be verified

Table continues on the next page...

Table 28-27. Read 1s Block Command FCCOB Requirements (continued)

FCCOB Number	FCCOB Contents [7:0]
3	Flash address [7:0] ¹ in the flash block to be verified
4	Read-1 Margin Choice

1. Must be longword aligned (Flash address [1:0] = 00).

After clearing CCIF to launch the Read 1s Block command, the FTFL sets the read margin for 1s according to [Table 28-28](#) and then reads all locations within the selected program flash block.

Table 28-28. Margin Level Choices for Read 1s Block

Read Margin Choice	Margin Level Description
0x00	Use the 'normal' read level for 1s
0x01	Apply the 'User' margin to the normal read-1 level
0x02	Apply the 'Factory' margin to the normal read-1 level

Table 28-29. Read 1s Block Command Error Handling

Error Condition	Error Bit
Command not available in current mode/security	FSTAT[ACCERR]
An invalid margin choice is specified	FSTAT[ACCERR]
Program flash is selected and the address is out of program flash range	FSTAT[ACCERR]
Flash address is not longword aligned	FSTAT[ACCERR]
Read-1s fails	FSTAT[MGSTAT0]

28.4.10.2 Read 1s Section Command

The Read 1s Section command checks if a section of program flash memory is erased to the specified read margin level. The Read 1s Section command defines the starting address and the number of phrases to be verified.

Table 28-30. Read 1s Section Command FCCOB Requirements

FCCOB Number	FCCOB Contents [7:0]
0	0x01 (RD1SEC)
1	Flash address [23:16] of the first phrase to be verified
2	Flash address [15:8] of the first phrase to be verified
3	Flash address [7:0] ¹ of the first phrase to be verified
4	Number of phrases to be verified [15:8]
5	Number of phrases to be verified [7:0]

Table continues on the next page...

Table 28-30. Read 1s Section Command FCCOB Requirements (continued)

FCCOB Number	FCCOB Contents [7:0]
6	Read-1 Margin Choice

1. Must be phrase aligned (Flash address [2:0] = 000).

Upon clearing CCIF to launch the Read 1s Section command, the FTFL sets the read margin for 1s according to [Table 28-31](#) and then reads all locations within the specified section of flash memory. If the FTFL fails to read all 1s (i.e. the flash section is not erased), the FSTAT(MGSTAT0) bit is set. The CCIF flag sets after the Read 1s Section operation completes.

Table 28-31. Margin Level Choices for Read 1s Section

Read Margin Choice	Margin Level Description
0x00	Use the 'normal' read level for 1s
0x01	Apply the 'User' margin to the normal read-1 level
0x02	Apply the 'Factory' margin to the normal read-1 level

Table 28-32. Read 1s Section Command Error Handling

Error Condition	Error Bit
Command not available in current mode/security	FSTAT[ACCERR]
An invalid margin code is supplied	FSTAT[ACCERR]
An invalid flash address is supplied	FSTAT[ACCERR]
Flash address is not phrase aligned	FSTAT[ACCERR]
The requested section crosses a Flash block boundary	FSTAT[ACCERR]
The requested number of phrases is zero	FSTAT[ACCERR]
Read-1s fails	FSTAT[MGSTAT0]

28.4.10.3 Program Check Command

The Program Check command tests a previously programmed program flash longword to see if it reads correctly at the specified margin level.

Table 28-33. Program Check Command FCCOB Requirements

FCCOB Number	FCCOB Contents [7:0]
0	0x02 (PGMCHK)
1	Flash address [23:16]
2	Flash address [15:8]
3	Flash address [7:0] ¹

Table continues on the next page...

Table 28-33. Program Check Command FCCOB Requirements (continued)

FCCOB Number	FCCOB Contents [7:0]
4	Margin Choice
8	Byte 0 expected data
9	Byte 1 expected data
A	Byte 2 expected data
B	Byte 3 expected data

1. Must be longword aligned (Flash address [1:0] = 00).

Upon clearing CCIF to launch the Program Check command, the FTFL sets the read margin for 1s according to [Table 28-34](#), reads the specified longword, and compares the actual read data to the expected data provided by the FCCOB. If the comparison at margin-1 fails, the MGSTAT0 bit is set.

The FTFL then sets the read margin for 0s, re-reads, and compares again. If the comparison at margin-0 fails, the MGSTAT0 bit is set. The CCIF flag is set after the Program Check operation completes.

The supplied address must be longword aligned (the lowest two bits of the byte address must be 00):

- Byte 0 data is expected at the supplied address ('start'),
- Byte 1 data is expected at byte address start + 0b01,
- Byte 2 data is expected at byte address start + 0b10, and
- Byte 3 data is expected at byte address start + 0b11.

NOTE

See the description of margin reads, [Margin Read Commands](#)

Table 28-34. Margin Level Choices for Program Check

Read Margin Choice	Margin Level Description
0x01	Read at 'User' margin-1 and 'User' margin-0
0x02	Read at 'Factory' margin-1 and 'Factory' margin-0

Table 28-35. Program Check Command Error Handling

Error Condition	Error Bit
Command not available in current mode/security	FSTAT[ACCERR]
An invalid flash address is supplied	FSTAT[ACCERR]
Flash address is not longword aligned	FSTAT[ACCERR]
An invalid margin choice is supplied	FSTAT[ACCERR]
Either of the margin reads does not match the expected data	FSTAT[MGSTAT0]

28.4.10.4 Read Resource Command

The Read Resource command allows the user to read data from special-purpose memory resources located within the FTFM module. The special-purpose memory resources available include program flash IFR space and the Version ID field. Each resource is assigned a select code as shown in [Table 28-37](#).

Table 28-36. Read Resource Command FCCOB Requirements

FCCOB Number	FCCOB Contents [7:0]
0	0x03 (RDRSRC)
1	Flash address [23:16]
2	Flash address [15:8]
3	Flash address [7:0] ¹
Returned Values	
4	Read Data [31:24]
5	Read Data [23:16]
6	Read Data [15:8]
7	Read Data [7:0]
User-provided values	
8	Resource Select Code (see Table 28-37)

1. Must be longword aligned (Flash address [1:0] = 00).

Table 28-37. Read Resource Select Codes

Resource Select Code	Description	Resource Size	Local Address Range
0x00	IFR	256 Bytes	0x0000 - 0x00FF
0x01 ¹	Version ID	8 Bytes	0x0000 - 0x0007

1. Located in program flash 0 reserved space; Flash address [23] = 0

After clearing CCIF to launch the Read Resource command, four consecutive bytes are read from the selected resource at the provided relative address and stored in the FCCOB register. The CCIF flag sets after the Read Resource operation completes. The Read Resource command exits with an access error if an invalid resource code is provided or if the address for the applicable area is out-of-range.

Table 28-38. Read Resource Command Error Handling

Error Condition	Error Bit
Command not available in current mode/security	FSTAT[ACCERR]
An invalid resource code is entered	FSTAT[ACCERR]

Table continues on the next page...

Table 28-38. Read Resource Command Error Handling (continued)

Error Condition	Error Bit
Flash address is out-of-range for the targeted resource.	FSTAT[ACCERR]
Flash address is not longword aligned	FSTAT[ACCERR]

28.4.10.5 Program Longword Command

The Program Longword command programs four previously-erased bytes in the program flash memory using an embedded algorithm.

CAUTION

A Flash memory location must be in the erased state before being programmed. Cumulative programming of bits (back-to-back program operations without an intervening erase) within a Flash memory location is not allowed. Re-programming of existing 0s to 0 is not allowed as this overstresses the device.

Table 28-39. Program Longword Command FCCOB Requirements

FCCOB Number	FCCOB Contents [7:0]
0	0x06 (PGM4)
1	Flash address [23:16]
2	Flash address [15:8]
3	Flash address [7:0] ¹
4	Byte 0 program value
5	Byte 1 program value
6	Byte 2 program value
7	Byte 3 program value

1. Must be longword aligned (Flash address [1:0] = 00).

Upon clearing CCIF to launch the Program Longword command, the FTFL programs the data bytes into the flash using the supplied address. The swap indicator address in each program flash block is implicitly protected from programming. The targeted flash locations must be currently unprotected (see the description of the FPROT registers) to permit execution of the Program Longword operation.

The programming operation is unidirectional. It can only move NVM bits from the erased state ('1') to the programmed state ('0'). Erased bits that fail to program to the '0' state are flagged as errors in MGSTAT0. The CCIF flag is set after the Program Longword operation completes.

The supplied address must be longword aligned (flash address [1:0] = 00):

- Byte 0 data is written to the supplied address ('start'),
- Byte 1 data is programmed to byte address start+0b01,
- Byte 2 data is programmed to byte address start+0b10, and
- Byte 3 data is programmed to byte address start+0b11.

Table 28-40. Program Longword Command Error Handling

Error Condition	Error Bit
Command not available in current mode/security	FSTAT[ACCERR]
An invalid flash address is supplied	FSTAT[ACCERR]
Flash address is not longword aligned	FSTAT[ACCERR]
Flash address points to a protected area	FSTAT[FPVIOL]
Any errors have been encountered during the verify operation	FSTAT[MGSTAT0]

28.4.10.6 Erase Flash Block Command

The Erase Flash Block operation erases all addresses in a single program flash.

Table 28-41. Erase Flash Block Command FCCOB Requirements

FCCOB Number	FCCOB Contents [7:0]
0	0x08 (ERSBLK)
1	Flash address [23:16] in the flash block to be erased
2	Flash address [15:8] in the flash block to be erased
3	Flash address [7:0] ¹ in the flash block to be erased

1. Must be longword aligned (Flash address [1:0] = 00).

Upon clearing CCIF to launch the Erase Flash Block command, the FTFLE erases the main array of the selected flash block and verifies that it is erased. The Erase Flash Block command aborts and sets the FSTAT[FPVIOL] bit if any region within the block is protected (see the description of the FPROT registers). The swap indicator address in each program flash block is implicitly protected from block erase unless the swap system is in the UPDATE or UPDATE-ERASED state and the program flash block being erased is the non-active block. If the erase verify fails, the MGSTAT0 bit in FSTAT is set. The CCIF flag will set after the Erase Flash Block operation has completed.

Table 28-42. Erase Flash Block Command Error Handling

Error Condition	Error Bit
Command not available in current mode/security	FSTAT[ACCERR]

Table continues on the next page...

Table 28-42. Erase Flash Block Command Error Handling (continued)

Error Condition	Error Bit
Program flash is selected and the address is out of program flash range	FSTAT[ACCERR]
Flash address is not longword aligned	FSTAT[ACCERR]
Any area of the selected flash block is protected	FSTAT[FPVIOL]
Any errors have been encountered during the verify operation	FSTAT[MGSTAT0]

28.4.10.7 Erase Flash Sector Command

The Erase Flash Sector operation erases all addresses in a Flash sector.

Table 28-43. Erase Flash Sector Command FCCOB Requirements

FCCOB Number	FCCOB Contents [7:0]
0	0x09 (ERSSCR)
1	Flash address [23:16] in the flash sector to be erased
2	Flash address [15:8] in the flash sector to be erased
3	Flash address [7:0] ¹ in the flash sector to be erased

1. Must be phrase aligned (flash address [2:0] = 000).

After clearing CCIF to launch the Erase Flash Sector command, the FTFL erases the selected program flash sector and then verifies that it is erased. The Erase Flash Sector command aborts if the selected sector is protected (see the description of the FPROT registers). The swap indicator address in each program flash block is implicitly protected from sector erase unless the swap system is in the UPDATE or UPDATE-ERASED state and the program flash sector containing the swap indicator address being erased is the non-active block. If the erase-verify fails the FSTAT[MGSTAT0] bit is set. The CCIF flag is set after the Erase Flash Sector operation completes. The Erase Flash Sector command is suspendable (see the FCNFG[ERSSUSP] bit and [Figure 28-25](#)).

Table 28-44. Erase Flash Sector Command Error Handling

Error Condition	Error Bit
Command not available in current mode/security	FSTAT[ACCERR]
An invalid Flash address is supplied	FSTAT[ACCERR]
Flash address is not phrase aligned	FSTAT[ACCERR]
The selected program flash sector is protected	FSTAT[FPVIOL]
Any errors have been encountered during the verify operation	FSTAT[MGSTAT0]

28.4.10.7.1 Suspending an Erase Flash Sector Operation

To suspend an Erase Flash Sector operation set the FCNFG[ERSSUSP] bit (see [Flash Configuration Field Description](#)) when CCIF is clear and the CCOB command field holds the code for the Erase Flash Sector command. During the Erase Flash Sector operation (see [Erase Flash Sector Command](#)), the FTFL samples the state of the ERSSUSP bit at convenient points. If the FTFL detects that the ERSSUSP bit is set, the Erase Flash Sector operation is suspended and the FTFL sets CCIF. While ERSSUSP is set, all writes to FTFL registers are ignored except for writes to the FSTAT and FCNFG registers.

If an Erase Flash Sector operation effectively completes before the FTFL detects that a suspend request has been made, the FTFL clears the ERSSUSP bit prior to setting CCIF. When an Erase Flash Sector operation has been successfully suspended, the FTFL sets CCIF and leaves the ERSSUSP bit set. While CCIF is set, the ERSSUSP bit can only be cleared to prevent the withdrawal of a suspend request before the FTFL has acknowledged it.

28.4.10.7.2 Resuming a Suspended Erase Flash Sector Operation

If the ERSSUSP bit is still set when CCIF is cleared to launch the next command, the previous Erase Flash Sector operation resumes. The FTFL acknowledges the request to resume a suspended operation by clearing the ERSSUSP bit. A new suspend request can then be made by setting ERSSUSP. A single Erase Flash Sector operation can be suspended and resumed multiple times.

There is a minimum elapsed time limit between the request to resume the Erase Flash Sector operation (CCIF is cleared) and the request to suspend the operation again (ERSSUSP is set). This minimum time period is required to ensure that the Erase Flash Sector operation will eventually complete. If the minimum period is continually violated, i.e. the suspend requests come repeatedly and too quickly, no forward progress is made by the Erase Flash Sector algorithm. The resume/suspend sequence runs indefinitely without completing the erase.

28.4.10.7.3 Aborting a Suspended Erase Flash Sector Operation

The user may choose to abort a suspended Erase Flash Sector operation by clearing the ERSSUSP bit prior to clearing CCIF for the next command launch. When a suspended operation is aborted, the FTFL starts the new command using the new FCCOB contents.

Note

Aborting the erase leaves the bitcells in an indeterminate, partially-erased state. Data in this sector is not reliable until a new erase command fully completes.

The following figure shows how to suspend and resume the Erase Flash Sector operation.

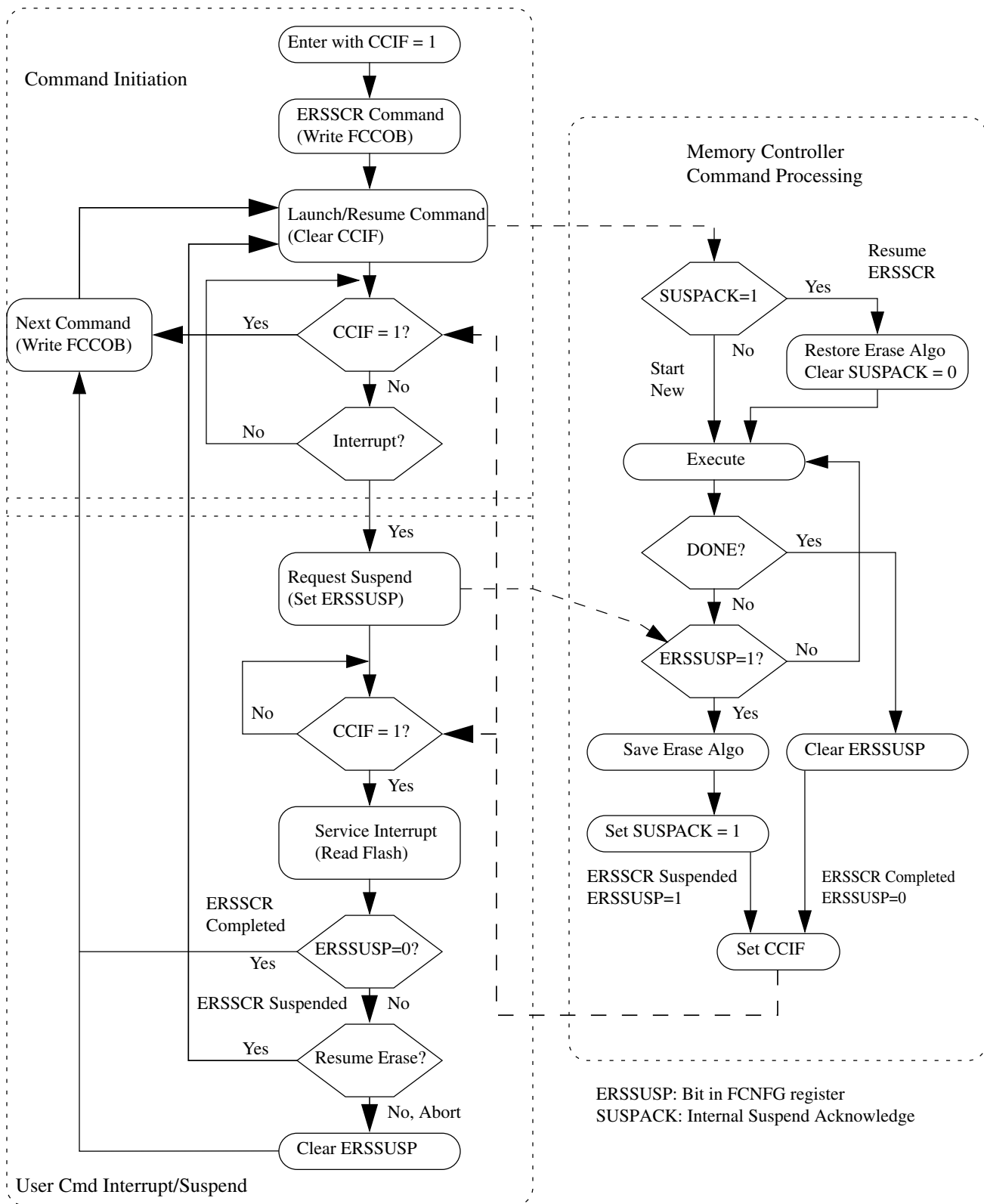

Figure 28-25. Suspend and Resume of Erase Flash Sector Operation

28.4.10.8 Program Section Command

The Program Section operation programs the data found in the section program buffer to previously erased locations in the flash memory using an embedded algorithm. Data is preloaded into the section program buffer (see [Flash Sector Programming](#)).

The section program buffer is limited to the lower half of the RAM. Data written to the upper half of the RAM is ignored and may be overwritten during Program Section command execution.

CAUTION

A flash memory location must be in the erased state before being programmed. Cumulative programming of bits (back-to-back program operations without an intervening erase) within a flash memory location is not allowed. Re-programming of existing 0s to 0 is not allowed as this overstresses the device.

Table 28-45. Program Section Command FCCOB Requirements

FCCOB Number	FCCOB Contents [7:0]
0	0x0B (PGMSEC)
1	Flash address [23:16]
2	Flash address [15:8]
3	Flash address [7:0] ¹
4	Number of phrases to program [15:8]
5	Number of phrases to program [7:0]

1. Must be phrase aligned (Flash address [2:0] = 000).

After clearing CCIF to launch the Program Section command, the FTFE blocks access to the programming acceleration RAM and programs the data residing in the section program buffer into the flash memory starting at the flash address provided.

The starting address must be unprotected (see the description of the FPROT registers) to permit execution of the Program Section operation. The swap indicator address in each program flash block is implicitly protected from erase. If the swap indicator address is encountered during the Program Section operation, it is bypassed without setting FPVIOL and the contents are not programmed. Programming, which is not allowed to cross a flash sector boundary, continues until all requested phrases have been programmed. The Program Section command also verifies that after programming, all bits requested to be programmed are programmed.

After the Program Section operation completes, the CCIF flag is set. The contents of the section program buffer may be changed by the Program Section operation.

Table 28-46. Program Section Command Error Handling

Error Condition	Error Bit
Command not available in current mode/security	FSTAT[ACCERR]
An invalid flash address is supplied	FSTAT[ACCERR]
Flash address is not phrase aligned	FSTAT[ACCERR]
The requested section crosses a program flash sector boundary	FSTAT[ACCERR]
The requested number of phrases is zero	FSTAT[ACCERR]
The space required to store data for the requested number of phrases is more than half the size of the programming acceleration RAM	FSTAT[ACCERR]
The flash address falls in a protected area	FSTAT[FPVIOL]
Any errors have been encountered during the verify operation	FSTAT[MGSTAT0]

28.4.10.8.1 Flash Sector Programming

The process of programming an entire flash sector using the Program Section command is as follows:

1. Launch the Erase Flash Sector command to erase the flash sector to be programmed.
2. Beginning with the starting address of the programming acceleration RAM, sequentially write enough data to the RAM to fill an entire flash sector. This area of the RAM serves as the section program buffer. The section program buffer can be written to while the operation launched in step 1 is executing, i.e. while CCIF = 0.
3. Execute the Program Section command to program the contents of the section program buffer into the selected flash sector.
4. To program additional flash sectors, repeat steps 1 through 3.

28.4.10.9 Read 1s All Blocks Command

The Read 1s All Blocks command checks if the program flash blocks have been erased to the specified read margin level, if applicable, and releases security if the readout passes, i.e. all data reads as '1'.

Table 28-47. Read 1s All Blocks Command FCCOB Requirements

FCCOB Number	FCCOB Contents [7:0]
0	0x40 (RD1ALL)
1	Read-1 Margin Choice

After clearing CCIF to launch the Read 1s All Blocks command, the FTFL :

- sets the read margin for 1s according to [Table 28-48](#),
- checks the contents of the program flash are in the erased state.

If the FTFL confirms that these memory resources are erased, security is released by setting the FSEC[SEC] field to the unsecure state. The security byte in the flash configuration field (see [Flash Configuration Field Description](#)) remains unaffected by the Read 1s All Blocks command. If the read fails, i.e. all memory resources are not in the fully erased state, the FSTAT[MGSTAT0] bit is set.

The EEERDY and RAMRDY bits are clear during the Read 1s All Blocks operation and are restored at the end of the Read 1s All Blocks operation.

The CCIF flag sets after the Read 1s All Blocks operation has completed.

Table 28-48. Margin Level Choices for Read 1s All Blocks

Read Margin Choice	Margin Level Description
0x00	Use the 'normal' read level for 1s
0x01	Apply the 'User' margin to the normal read-1 level
0x02	Apply the 'Factory' margin to the normal read-1 level

Table 28-49. Read 1s All Blocks Command Error Handling

Error Condition	Error Bit
An invalid margin choice is specified	FSTAT[ACCERR]
Read-1s fails	FSTAT[MGSTAT0]

28.4.10.10 Read Once Command

The Read Once command provides read access to a reserved 64-byte field located in the program flash 0 IFR (see [Program Flash IFR Map](#) and [Program Once Field](#)). Access to this field is via 16 records, each 4 bytes long. The Read Once field is programmed using the Program Once command described in [Program Once Command](#).

Table 28-50. Read Once Command FCCOB Requirements

FCCOB Number	FCCOB Contents [7:0]
0	0x41 (RDONCE)
1	Read Once record index (0x00 - 0x0F)
2	Not used
3	Not used

Table continues on the next page...

Table 28-50. Read Once Command FCCOB Requirements (continued)

FCCOB Number	FCCOB Contents [7:0]
Returned Values	
4	Read Once byte 0 value
5	Read Once byte 1 value
6	Read Once byte 2 value
7	Read Once byte 3 value

After clearing CCIF to launch the Read Once command, a 4-byte Read Once record is read from the program flash IFR and stored in the FCCOB register. The CCIF flag is set after the Read Once operation completes. Valid record index values for the Read Once command range from 0x00 to 0x0F. During execution of the Read Once command, any attempt to read addresses within the program flash block containing this 64-byte field returns invalid data. The Read Once command can be executed any number of times.

Table 28-51. Read Once Command Error Handling

Error Condition	Error Bit
Command not available in current mode/security	FSTAT[ACCERR]
An invalid record index is supplied	FSTAT[ACCERR]

28.4.10.11 Program Once Command

The Program Once command enables programming to a reserved 64-byte field in the program flash 0 IFR (see [Program Flash IFR Map](#) and [Program Once Field](#)). Access to the Program Once field is via 16 records, each 4 bytes long. The Program Once field can be read using the Read Once command (see [Read Once Command](#)) or using the Read Resource command (see [Read Resource Command](#)). Each Program Once record can be programmed only once since the program flash 0 IFR cannot be erased.

Table 28-52. Program Once Command FCCOB Requirements

FCCOB Number	FCCOB Contents [7:0]
0	0x43 (PGMONCE)
1	Program Once record index (0x00 - 0x0F)
2	Not Used
3	Not Used
4	Program Once Byte 0 value
5	Program Once Byte 1 value
6	Program Once Byte 2 value

Table continues on the next page...

Table 28-52. Program Once Command FCCOB Requirements (continued)

FCCOB Number	FCCOB Contents [7:0]
7	Program Once Byte 3 value

After clearing CCIF to launch the Program Once command, the FTFLL first verifies that the selected record is erased. If erased, then the selected record is programmed using the values provided. The Program Once command also verifies that the programmed values read back correctly. The CCIF flag is set after the Program Once operation has completed.

The reserved program flash 0 IFR location accessed by the Program Once command cannot be erased and any attempt to program one of these records when the existing value is not Fs (erased) is not allowed. Valid record index values for the Program Once command range from 0x00 to 0x0F. During execution of the Program Once command, any attempt to read addresses within program flash 0 returns invalid data.

Table 28-53. Program Once Command Error Handling

Error Condition	Error Bit
Command not available in current mode/security	FSTAT[ACCERR]
An invalid record index is supplied	FSTAT[ACCERR]
The requested record has already been programmed to a non-FFFF value ¹	FSTAT[ACCERR]
Any errors have been encountered during the verify operation	FSTAT[MGSTAT0]

1. If a Program Once record is initially programmed to 0xFFFF_FFFF, the Program Once command is allowed to execute again on that same record.

28.4.10.12 Erase All Blocks Command

The Erase All Blocks operation erases all flash memory, verifies all memory contents, and releases MCU security.

Table 28-54. Erase All Blocks Command FCCOB Requirements

FCCOB Number	FCCOB Contents [7:0]
0	0x44 (ERSALL)

After clearing CCIF to launch the Erase All Blocks command, the FTFLL erases all program flash memory, program flash 1 IFR space, then verifies that all are erased.

If the FTFLL verifies that all flash memories were properly erased, security is released by setting the FSEC[SEC] field to the unsecure state and the FCNFG[RAMRDY] bit is set. The Erase All Blocks command aborts if any flash region is protected. The swap indicator address in each program flash block is not implicitly protected from the Erase

All Blocks operation. The security byte and all other contents of the flash configuration field (see [Flash Configuration Field Description](#)) are erased by the Erase All Blocks command. If the erase-verify fails, the FSTAT[MGSTAT0] bit is set. The CCIF flag is set after the Erase All Blocks operation completes.

Table 28-55. Erase All Blocks Command Error Handling

Error Condition	Error Bit
Command not available in current mode/security	FSTAT[ACCERR]
Any region of the program flash memory is protected	FSTAT[FPVIOL]
Any errors have been encountered during the verify operation	FSTAT[MGSTAT0]

28.4.10.12.1 Triggering an Erase All External to the FTFL

The functionality of the Erase All Blocks command is also available in an uncommanded fashion outside of the flash memory. Refer to the device's Chip Configuration details for information on this functionality.

Before invoking the external erase all function, the FSTAT[ACCERR and PVIOL] flags must be cleared and the FCCOB0 register must not contain 0x44. When invoked, the erase-all function erases all program flash memory, program flash 1 IFR space regardless of the protection settings or if the swap system has been initialized. If the post-erase verify passes, the routine then releases security by setting the FSEC[SEC] field register to the unsecure state and the FCNFG[RAMRDY] bit sets. The security byte in the Flash Configuration Field is also programmed to the unsecure state. The status of the erase-all request is reflected in the FCNFG[ERSAREQ] bit. The FCNFG[ERSAREQ] bit is cleared once the operation completes and the normal FSTAT error reporting is available as described in [Erase All Blocks Command](#).

28.4.10.13 Verify Backdoor Access Key Command

The Verify Backdoor Access Key command only executes if the mode and security conditions are satisfied (see [FTFL Commands by Mode](#)). Execution of the Verify Backdoor Access Key command is further qualified by the FSEC[KEYEN] bits. The Verify Backdoor Access Key command releases security if user-supplied keys in the FCCOB match those stored in the Backdoor Comparison Key bytes of the Flash Configuration Field (see [Flash Configuration Field Description](#)). The column labelled Flash Configuration Field offset address shows the location of the matching byte in the Flash Configuration Field.

Table 28-56. Verify Backdoor Access Key Command FCCOB Requirements

FCCOB Number	FCCOB Contents [7:0]	Flash Configuration Field Offset Address
0	0x45 (VFYKEY)	
1-3	Not Used	
4	Key Byte 0	0x0_0000
5	Key Byte 1	0x0_0001
6	Key Byte 2	0x0_0002
7	Key Byte 3	0x0_0003
8	Key Byte 4	0x0_0004
9	Key Byte 5	0x0_0005
A	Key Byte 6	0x0_0006
B	Key Byte 7	0x0_0007

After clearing CCIF to launch the Verify Backdoor Access Key command, the FTFM checks the FSEC[KEYEN] bits to verify that this command is enabled. If not enabled, the FTFM sets the FSTAT[ACCERR] bit and terminates. If the command is enabled, the FTFM compares the key provided in FCCOB to the backdoor comparison key in the Flash Configuration Field. If the backdoor keys match, the FSEC[SEC] field is changed to the unsecure state and security is released. If the backdoor keys do not match, security is not released and all future attempts to execute the Verify Backdoor Access Key command are immediately aborted and the FSTAT[ACCERR] bit is (again) set to 1 until a reset of the FTFM module occurs. If the entire 8-byte key is all zeros or all ones, the Verify Backdoor Access Key command fails with an access error. The CCIF flag is set after the Verify Backdoor Access Key operation completes.

Table 28-57. Verify Backdoor Access Key Command Error Handling

Error Condition	Error Bit
The supplied key is all-0s or all-Fs	FSTAT[ACCERR]
An incorrect backdoor key is supplied	FSTAT[ACCERR]
Backdoor key access has not been enabled (see the description of the FSEC register)	FSTAT[ACCERR]
This command is launched and the backdoor key has mismatched since the last power down reset	FSTAT[ACCERR]

28.4.10.14 Swap Control Command

The Swap Control command handles specific activities associated with swapping the two logical program flash memory blocks within the memory map.

Table 28-58. Swap Control Command FCCOB Requirements

FCCOB Number	FCCOB Contents [7:0]
0	0x46 (SWAP)
1	Flash address [23:16]
2	Flash address [15:8]
3	Flash address [7:0] ¹
4	Swap Control Code: 0x01 - Initialize Swap System 0x02 - Set Swap in Update State 0x04 - Set Swap in Complete State 0x08 - Report Swap Status
Returned values	
5	Current Swap State: 0x00 - Uninitialized 0x01 - Ready 0x02 - Update 0x03 - Update-Erased 0x04 - Complete
6	Current Swap Block Status: 0x00 - Program flash block 0 at 0x0_0000 0x01 - Program flash block 1 at 0x0_0000
7	Next Swap Block Status (after any reset): 0x00 - Program flash block 0 at 0x0_0000 0x01 - Program flash block 1 at 0x0_0000

1. Must be phrase-aligned (Flash address [2:0] = 000).

Upon clearing CCIF to launch the Swap Control command, the FTFL will handle swap-related activities based on the swap control code provided in FCCOB4 as follows:

- 0x01 (Initialize Swap System to UPDATE-ERASED State) - After verifying that the current swap state is UNINITIALIZED and that the flash address provided is in Program flash block 0 but not in the Flash Configuration Field, the flash address (shifted with bits[2:0] removed) will be programmed into the IFR Swap Field found in program flash 1 IFR. After the swap indicator address has been programmed into the IFR Swap Field, the swap enable word will be programmed to 0x0000. After the swap enable word has been programmed, the swap indicator, located within the Program flash block 0 address provided, will be programmed to 0xFF00.
- 0x02 (Progress Swap to UPDATE State) - After verifying that the current swap state is READY and that the flash address provided matches the one stored in the IFR Swap Field, the swap indicator located within bits [15:0] of the flash address in the currently active program flash block will be programmed to 0xFF00.

- 0x04 (Progress Swap to COMPLETE State) - After verifying that the current swap state is UPDATE-ERASED and that the flash address provided matches the one stored in the IFR Swap Field, the swap indicator located within bits [15:0] of the flash address in the currently active program flash block will be programmed to 0x0000. Before executing with this swap control code, the user must erase the non-active swap indicator using the Erase Flash Block or Erase Flash Sector commands and update the application code or data as needed. The non-active swap indicator will be checked at the erase verify level and if the check fails, the current swap state will be changed to UPDATE with ACCERR set.
- 0x08 (Report Swap System Status) - After verifying that the flash address provided matches the one stored in the IFR Swap Field, the status of the swap system will be reported as follows:
 - FCCOB5 (Current Swap State) - indicates the current swap state based on the status of the swap enable word and the swap indicators. If the MGSTAT0 flag is set after command completion, the swap state returned was not successfully transitioned from and the appropriate swap command code must be attempted again. If the current swap state is UPDATE and the non-active swap indicator is 0xFFFF, the current swap state is changed to UPDATE-ERASED.
 - FCCOB6 (Current Swap Block Status) - indicates which program flash block is currently located at relative flash address 0x0_0000.
 - FCCOB7 (Next Swap Block Status) - indicates which program flash block will be located at relative flash address 0x0_0000 after the next reset of the FTFL module.

NOTE

It is recommended that the user execute the Swap Control command to report swap status (code 0x08) after any reset to determine if issues with the swap system were detected during the swap state determination procedure.

NOTE

It is recommended that the user write 0xFF to FCCOB5, FCCOB6, and FCCOB7 since the Swap Control command will not always return the swap state and status fields when an ACCERR is detected.

The swap indicators are implicitly protected from being programmed during Program Longword or Program Section command operations and are implicitly unprotected during Swap Control command operations. The swap indicators are implicitly protected from being erased during Erase Flash Block and Erase Flash Sector command operations unless the swap indicator being erased is in the non-active program flash block and the

swap system is in the UPDATE or UPDATE-ERASED state. Once the swap system has been initialized, the Erase All Blocks command can be used to uninitialized the swap system.

Table 28-59. Swap Control Command Error Handling

Error Condition	Swap Control Code	Error Bit
Command not available in current mode/security ¹	All	FSTAT[ACCERR]
Flash address is not in program flash block 0	All	FSTAT[ACCERR]
Flash address is in the Flash Configuration Field	All	FSTAT[ACCERR]
Flash address is not phrase aligned	All	FSTAT[ACCERR]
Flash address does not match the swap indicator address in the IFR	2, 4	FSTAT[ACCERR]
Swap initialize requested when swap system is not in the uninitialized state	1	FSTAT[ACCERR]
Swap update requested when swap system is not in the ready state	2	FSTAT[ACCERR]
Swap complete requested when swap system is not in the update-erased state	4	FSTAT[ACCERR]
An undefined swap control code is provided	-	FSTAT[ACCERR]
Any errors have been encountered during the swap determination and program-verify operations	1, 2, 4	FSTAT[MGSTAT0]
Any brownouts were detected during the swap determination procedure	8	FSTAT[MGSTAT0]

1. Returned fields will not be updated, i.e. no swap state or status reporting

Block0 Active States Block1 Active States

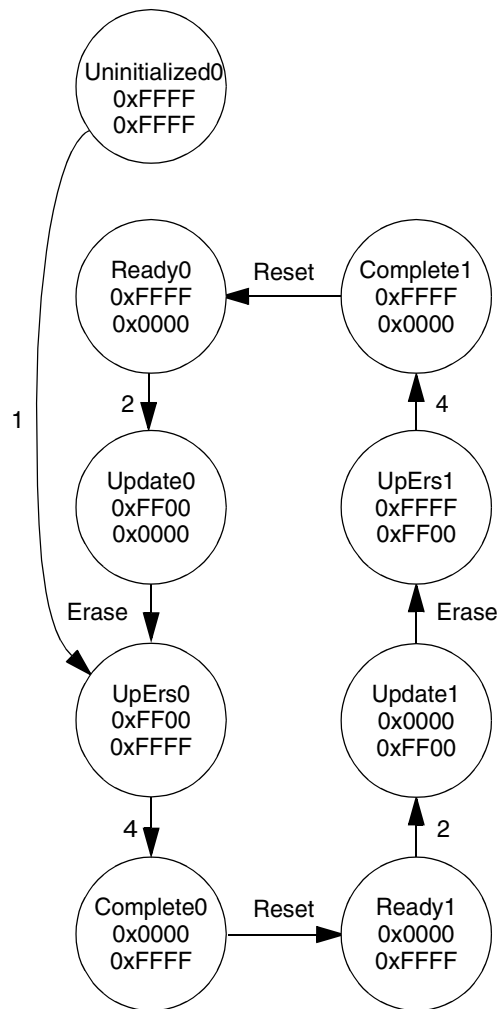

Legend

Swap State Indicator0
 Indicator1

Swap Control Code →

Erase: ERSBLK or ERSSCR commands
 Reset: POR, VLLSx exit, warm/system reset

Figure 28-26. Valid Swap State Sequencing

Table 28-60. Swap State Report Mapping

Case	Swap Enable Field ¹	Swap Indicator 0 ¹	Swap Indicator 1 ¹	Swap State ²	State Code	MGST AT0	Active Block
1	0xFFFF	-	-	Uninitialized	0	0	0
2	0x0000	0xFF00	0x0000	Update	2	0	0
3	0x0000	0xFF00-	0xFFFF	Update-Erased	3	0	0
4	0x0000	0x0000	0xFFFF ³	Complete ⁴	4	0	0
5	0x0000	0x0000	0xFFFF	Ready ⁵	1	0	1
6	0x0000	0x0000	0xFF00	Update	2	0	1
7	0x0000	0xFFFF	0xFF00	Update-Erased	3	0	1
8	0x0000	0xFFFF ³	0x0000	Complete ⁴	4	0	1
9	0x0000	0xFFFF	0x0000	Ready ⁵	1	0	0
10	0XXXX	-	-	Uninitialized	0	1	0
11	0x0000	0xFFFF	0xFFFF	Uninitialized	0	1	0
12	0x0000	0xFFXX	0xFFFF	Ready	1	1	0
13	0x0000	0xFFXX	0x0000	Ready	1	1	0
14 ⁶	0x0000	0XXXX	0x0000	Ready	1	1	0
15 ⁶	0x0000	0xFFFF	0xFFXX	Ready	1	1	1
16	0x0000	0x0000	0xFFXX	Ready	1	1	1
17 ⁶	0x0000	0x0000	0XXXX	Ready	1	1	1
18	0x0000	0xFF00	0xFFFF ⁷	Update	2	1	0
19	0x0000	0xFF00	0XXXX	Update	2	1	0
20	0x0000	0xFF(00)	0xFFXX	Update	2	1	0
21 ⁶	0x0000	0x0000	0x0000	Update	2	1	0
22 ⁶	0x0000	0XXXX	0XXXX	Update	2	1	0
23	0x0000	0xFFFF ⁷	0xFF00	Update	2	1	1
24	0x0000	0XXXX	0xFF00	Update	2	1	1
25	0x0000	0xFFXX	0xFF(00)	Update	2	1	1
26	0x0000	0XX00	0xFFFF	Update-Erased	3	1	0
27	0x0000	0XXXX	0xFFFF	Update-Erased	3	1	0
28	0x0000	0xFFFF	0XX00	Update-Erased	3	1	1
29	0x0000	0xFFFF	0XXXX	Update-Erased	3	1	1

1. 0XXXX, 0xFFXX, 0XX00 indicates a non-valid value was read; 0xFF(00) indicates more 0's than other indicator (if same number of 0's, then swap system defaults to block 0 active)
2. Cases 10-29 due to brownout (abort) detected during program or erase steps related to swap
3. Must read 0xFFFF with erase verify level before transition to Complete allowed
4. No reset since successful Swap Complete execution
5. Reset after successful Swap Complete execution
6. Not a valid case
7. Fails to read 0xFFFF at erase verify level

28.4.10.14.1 Swap State Determination

During the reset sequence, the state of the swap system is determined by evaluating the IFR Swap Field in the program flash 1 IFR and the swap indicators located in each of the program flash blocks at the swap indicator address stored in the IFR Swap Field.

Table 28-61. Program Flash 1 IFR Swap Field

Address Range	Size (Bytes)	Field Description
0x00 – 0x01	2	Swap Enable Word
0x02 – 0x03	2	Swap Indicator Address
0x04 – 0xFF	252	Reserved

28.4.11 Security

The FTFL module provides security information to the MCU based on contents of the FSEC security register. The MCU then limits access to FTFL resources as defined in the device's Chip Configuration details. During reset, the FTFL module initializes the FSEC register using data read from the security byte of the Flash Configuration Field (see [Flash Configuration Field Description](#)).

The following fields are available in the FSEC register. The settings are described in the [Flash Security Register \(FTFL_FSEC\)](#) details.

Table 28-62. FSEC register fields

FSEC field	Description
KEYEN	Backdoor Key Access
MEEN	Mass Erase Capability
FSLACC	Freescale Factory Access
SEC	MCU security

28.4.11.1 FTFL Access by Mode and Security

The following table summarizes how access to the FTFL module is affected by security and operating mode.

Table 28-63. FTFL Access Summary

Operating Mode	Chip Security State	
	Unsecure	Secure
NVM Normal	Full command set	
NVM Special	Full command set	Only the Erase All Blocks and Read 1s All Blocks commands.

28.4.11.2 Changing the Security State

The security state out of reset can be permanently changed by programming the security byte of the flash configuration field. This assumes that you are starting from a mode where the necessary program flash erase and program commands are available and that the region of the program flash containing the flash configuration field is unprotected. If the flash security byte is successfully programmed, its new value takes affect after the next chip reset.

28.4.11.2.1 Unsecuring the Chip Using Backdoor Key Access

The chip can be unsecured by using the backdoor key access feature, which requires knowledge of the contents of the 8-byte backdoor key value stored in the Flash Configuration Field (see [Flash Configuration Field Description](#)). If the FSEC[KEYEN] bits are in the enabled state, the Verify Backdoor Access Key command (see [Verify Backdoor Access Key Command](#)) can be run; it allows the user to present prospective keys for comparison to the stored keys. If the keys match, the FSEC[SEC] bits are changed to unsecure the chip. The entire 8-byte key cannot be all 0s or all 1s; that is, 0000_0000_0000_0000h and FFFF_FFFF_FFFF_FFFFh are not accepted by the Verify Backdoor Access Key command as valid comparison values. While the Verify Backdoor Access Key command is active, program flash memory is not available for read access and returns invalid data.

The user code stored in the program flash memory must have a method of receiving the backdoor keys from an external stimulus. This external stimulus would typically be through one of the on-chip serial ports.

If the KEYEN bits are in the enabled state, the chip can be unsecured by the following backdoor key access sequence:

1. Follow the command sequence for the Verify Backdoor Access Key command as explained in [Verify Backdoor Access Key Command](#)
2. If the Verify Backdoor Access Key command is successful, the chip is unsecured and the FSEC[SEC] bits are forced to the unsecure state

An illegal key provided to the Verify Backdoor Access Key command prohibits further use of the Verify Backdoor Access Key command. A reset of the chip is the only method to re-enable the Verify Backdoor Access Key command when a comparison fails.

After the backdoor keys have been correctly matched, the chip is unsecured by changing the FSEC[SEC] bits. A successful execution of the Verify Backdoor Access Key command changes the security in the FSEC register only. It does not alter the security byte or the keys stored in the Flash Configuration Field ([Flash Configuration Field Description](#)). After the next reset of the chip, the security state of the FTFM module reverts back to the flash security byte in the Flash Configuration Field. The Verify Backdoor Access Key command sequence has no effect on the program and erase protections defined in the program flash protection registers.

If the backdoor keys successfully match, the unsecured chip has full control of the contents of the Flash Configuration Field. The chip may erase the sector containing the Flash Configuration Field and reprogram the flash security byte to the unsecure state and change the backdoor keys to any desired value.

28.4.12 Reset Sequence

On each system reset the FTFM module executes a sequence which establishes initial values for the flash block configuration parameters, FPROT, FOPT, and FSEC registers and the FCNFG[SWAP, PFLSH, RAMRDY, EEERDY] bits.

CCIF is cleared throughout the reset sequence. The FTFM module holds off all CPU access for a portion of the reset sequence. Flash reads are possible when the hold is removed. Completion of the reset sequence is marked by setting CCIF which enables flash user commands.

If a reset occurs while any FTFM command is in progress, that command is immediately aborted. The state of the word being programmed or the sector/block being erased is not guaranteed. Commands and operations do not automatically resume after exiting reset.

Chapter 29

EzPort

29.1 Overview

NOTE

For the chip-specific implementation details of this module's instances see the chip configuration chapter.

EzPort is a serial flash programming interface that allows In-System Programming (ISP) of flash memory contents on a 32 bit general purpose micro-controller. Memory contents can be read, erased and programmed from off-chip in a compatible format to many stand-alone flash memory chips, without necessitating the removal of the micro-controller from the system.

29.1.1 Introduction

The block diagram of the EzPort is as following.

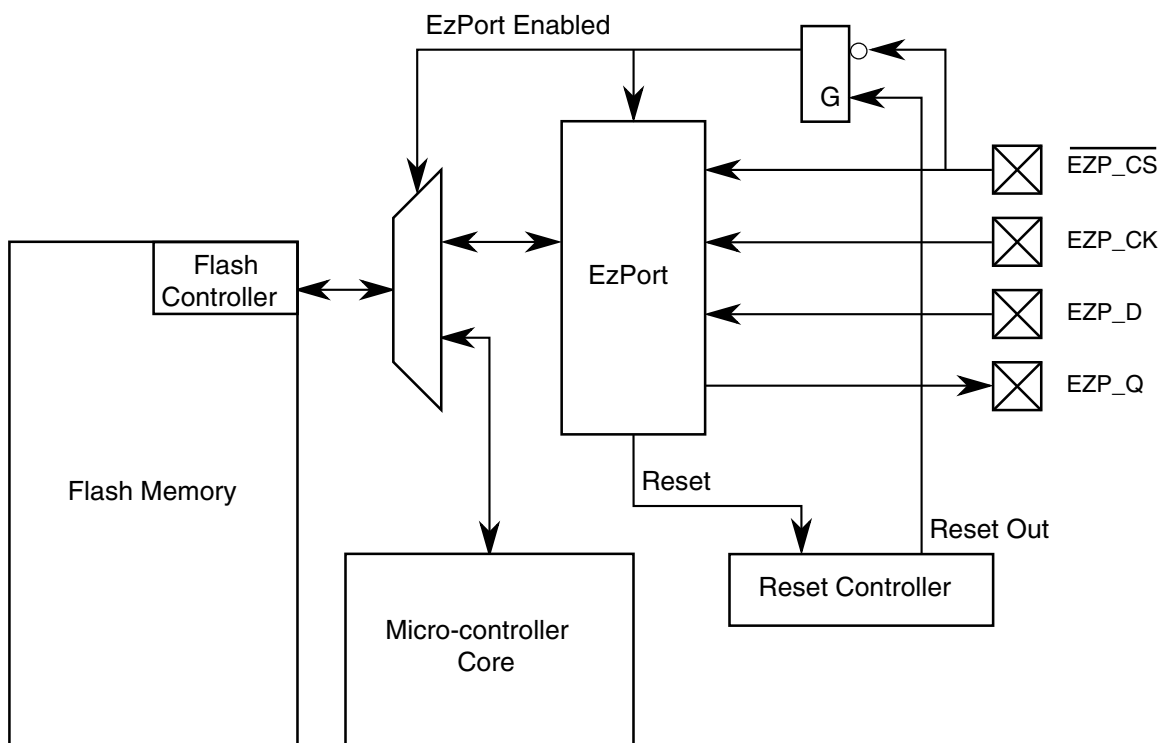

Figure 29-1. EzPort Block Diagram

29.1.2 Features

The EzPort includes the following features:

- Serial interface that is compatible with a subset of the SPI format.
- Able to read, erase and program flash memory.
- Able to reset the micro-controller, allowing it to boot from the flash memory after the memory has been configured.

29.1.3 Modes of Operation

The EzPort can operate in one of two different modes, enabled or disabled.

- Enabled — When enabled, the EzPort steals access to the flash memory, preventing access from other cores or peripherals. The rest of the microcontroller is disabled to avoid conflicts. The flash is configured for NVM Special Mode.
- Disabled — When the EzPort is disabled, the rest of the micro-controller can access flash memory as normal.

The EzPort provides a simple interface to connect an external device to the flash memory on board a 32 bit micro-controller. The interface itself is compatible with the SPI interface (with the EzPort operating as a slave) running in either of the two following modes with data transmitted most significant bit first:

- CPOL = 0, CPHA = 0
- CPOL = 1, CPHA = 1

Commands are issued by the external device to erase, program or read the contents of the flash memory. The serial data out from the EzPort is tri-stated unless data is being driven, allowing the signal to be shared among several different EzPort (or compatible) devices in parallel, provided they have different chip selects.

29.2 External Signal Description

The following table contains a list of EzPort external signals, and the following sections explain them in detail.

Table 29-1. EzPort External Signal Descriptions

Name	Description	I/O
EZP_CK	EzPort Clock	Input
EZP_CS	EzPort Chip Select	Input
EZP_D	EzPort Serial Data In	Input
EZP_Q	EzPort Serial Data Out	Output

29.2.1 EzPort Clock (EZP_CK)

Serial clock for data transfers. The serial data in (EZP_D) and chip select ($\overline{\text{EZP_CS}}$) are registered on the rising edge of EZP_CK while serial data out (EZP_Q) is driven on the falling edge of EZP_CK.

The maximum frequency of the EzPort clock is half the system clock frequency for all commands except when executing the Read Data commands. When executing these commands, the EzPort clock has a maximum frequency of one-eighth the system clock frequency.

29.2.2 EzPort Chip Select ($\overline{\text{EZP_CS}}$)

Chip select for signalling the start and end of serial transfers. If $\overline{\text{EZP_CS}}$ is asserted during and when the micro-controller's reset out signal is negated, then EzPort is enabled out of reset; otherwise it is disabled. After EzPort is enabled, asserting $\overline{\text{EZP_CS}}$ commences a serial data transfer, which continues until $\overline{\text{EZP_CS}}$ is negated again. The negation of $\overline{\text{EZP_CS}}$ indicates the current command is finished and resets the EzPort state machine so that it is ready to receive the next command.

29.2.3 EzPort Serial Data In (EZP_D)

Serial data in for data transfers. EZP_D is registered on the rising edge of EZP_CK. All commands, addresses, and data are shifted in most significant bit first. When the EzPort is driving output data on EZP_Q, the data shifted in EZP_D is ignored.

29.2.4 EzPort Serial Data Out (EZP_Q)

Serial data out for data transfers. EZP_Q is driven on the falling edge of EZP_CK. It is tri-stated unless $\overline{\text{EZP_CS}}$ is asserted and the EzPort is driving data out. All data is shifted out most significant bit first.

29.3 Command Definition

The EzPort receives commands from an external device and translates those commands into flash memory accesses. The following table lists the supported commands.

Table 29-2. EzPort Commands

Command	Description	Code	Address Bytes	Data Bytes	Accepted when secure?
WREN	Write Enable	0x06	0	0	Yes
WRDI	Write Disable	0x04	0	0	Yes
RDSR	Read Status Register	0x05	0	1	Yes
READ	Flash Read Data	0x03	3 ¹	1+	No
FAST_READ	Flash Read Data at High Speed	0x0B	3 ¹	1+ ²	No
SP	Flash Section Program	0x02	3 ³	8 - SECTION ⁴	No
SE	Flash Sector Erase	0xD8	3 ³	0	No
BE	Flash Bulk Erase	0xC7	0	0	Yes ⁵

Table continues on the next page...

Table 29-2. EzPort Commands (continued)

Command	Description	Code	Address Bytes	Data Bytes	Accepted when secure?
RESET	Reset Chip	0xB9	0	0	Yes
WRFCCOB	Write FCCOB Registers	0xBA	0	12	Yes ⁶
FAST_RDFCCOB	Read FCCOB registers at high speed	0xBB	0	1 - 12 ²	No

1. Address must be 32-bit aligned (two LSBs must be zero).
2. One byte of dummy data must be shifted in before valid data is shifted out.
3. Address must be 64-bit aligned (three LSBs must be zero).
4. A section is defined as half the size of the flash sector size. Total number of data bytes programmed must be a multiple of 8.
5. Bulk Erase is accepted when security is set only if the BEDIS status bit is not set.
6. Note that the Flash will be in NVM Special mode, restricting which types of commands can be executed through WRITE_FCCOB when security is enabled.

29.3.1 Command Descriptions

This section describes the module commands.

29.3.1.1 Write Enable

The Write Enable command (WREN) sets the write enable register bit in the EzPort status register. The write enable bit must be set for a write command (SP, SE, BE, WRFCCOB) to be accepted. The write enable register bit clears on reset, on a Write Disable command, and at the completion of write command. This command should not be used if a write is already in progress.

29.3.1.2 Write Disable

The Write Disable command (WRDI) clears the write enable register bit in the status register. This command should not be used if a write is already in progress.

29.3.1.3 Read Status Register

The Read Status Register command (RDSR) returns the contents of the EzPort status register.

Table 29-3. EzPort Status Register

	7	6	5	4	3	2	1	0
R	FS	WEF				BEDIS	WEN	WIP
W								
Reset:	0/1 ¹	0	0	0	0	0/1 ²	0	1 ³

1. Reset value reflects the status of flash security out of reset.
2. Reset value reflects if bulk erase is enabled or disabled out of reset
3. Initial value of WIP is 1, but the value clears to 0 after EzPort initialization is complete

Table 29-4. EzPort Status Register Field Descriptions

Field	Description
0 WIP	<p>Write in progress.</p> <p>Status flag that sets after a write command (SP, SE, BE, WRFFCOB) is accepted and clears once the flash memory has completed all operations associated with that command as indicated by the Command Complete Interrupt Flag (CCIF) inside the Flash. Also asserted on reset and clears when EzPort initialization is complete. Only the Read Status Register (RDSR) command is accepted while a write is in progress.</p> <p>0 = Write is not in progress. Accept any command. 1 = Write is in progress. Only accept RDSR command.</p>
1 WEN	<p>Write enable</p> <p>Control bit that must be set before a write command (SP, SE, BE, WRFFCOB) is accepted. Is set by the Write Enable (WREN) command and cleared by reset or a Write Disable (WRDI) command. It also clears when the flash memory has completed all operations associated with the command.</p> <p>0 = Disables the following write command. 1 = Enables the following write command.</p>
2 BEDIS	<p>Bulk erase disable</p> <p>Status flag which indicates if bulk erase (BE) is disabled when Flash is secure.</p> <p>0 = Bulk Erase is enabled. 1 = Bulk Erase is disabled if the FS bit is also set. Attempts to issue a BE command will result in the WEF flag being set.</p>
6 WEF	<p>Write error flag</p> <p>Status flag that indicates if there has been an error while executing a write command (SP, SE, BE, WRFFCOB). The WEF flag will set if either the Flash Access Error Flag (ACCERR) or the Flash Protection Violation Flag (FPVIOL) or the Memory Controller Command Completion Status Flag (MGSTAT0) inside the flash memory is set at the completion of the write command. See the flash memory chapter for further description of these flags and their sources. The WEF flag clears after a Read Status Register (RDSR) command.</p> <p>0 = No error on previous write command. 1 = Error on previous write command.</p>
7 FS	<p>Flash security</p> <p>Status flag that indicates if the flash is secure. See Table 29-2 for the list of commands which will be accepted when flash is secure. Flash security can be disabled by performing a Bulk Erase (BE) command.</p> <p>0 = Flash is not secure 1 = Flash is secure.</p>

29.3.1.4 Read Data

The Read Data (READ) command returns data from the flash memory. The initial address must be 32-bit aligned (the two LSBs must be zero).

Data continues being returned for as long as the EzPort chip select ($\overline{\text{EzP_CS}}$) is asserted, with the address automatically incrementing. In this way, the entire contents of flash can be returned by one command. Attempts to read from an address which does not fall within the valid address range (see [Flash Memory Map for EzPort Access](#)) for the flash memory regions returns junk data.

For this command to return the correct data, the EzPort clock (EzP_CK) must run at the internal system clock divided by eight or slower. This command is not accepted if the WEF, WIP, or FS bit in the EzPort status register is set.

29.3.1.5 Read Data at High Speed

The Read Data at High Speed command (FAST_READ) is identical to the READ command, except for the inclusion of a dummy byte following the address bytes and before the first data byte is returned.

This command can be run with an EzPort clock (EzP_CK) frequency of half the internal system clock frequency of the micro-controller or slower. This command is not accepted if the WEF, WIP, or FS bit in the EzPort status register is set.

29.3.1.6 Section Program

The Section Program (SP) command programs up to one section of flash memory which has previously been erased. A section is defined as the smaller of the flash sector size or half the size of the Programming Acceleration RAM. The starting address of the memory to program is sent after the command word and must be a 64-bit aligned address (the three LSBs must be zero).

As data is shifted in, the EzPort buffers the data in Programming Acceleration RAM before executing a 'Program Section' command within the flash (see [Flash Block Guide](#) for more detail). For this reason, the number of bytes to program must be a multiple of 8 and up to one flash section can be programmed at a time.

Attempts to program more than one section, across a sector boundary or from an initial address which does not fall within the valid address range (see [Flash Memory Map for EzPort Access](#)) for the flash causes the WEF flag to set.

This command is not accepted if the WEF, WIP, or FS bit is set or if the WEN bit is not set in the EzPort status register.

29.3.1.7 Sector Erase

The Sector Erase (SE) command erases the contents of one sector of flash memory. The three byte address sent after the command byte can be any address within the sector to erase, but must be a 64-bit aligned address (the three LSBs must be zero). Attempts to erase from an initial address which does not fall within the valid address range (see [Flash Memory Map for EzPort Access](#)) for the flash results in the WEF flag being set.

This command is not accepted if the WEF, WIP or FS bit is set or if the WEN bit is not set in the EzPort status register.

29.3.1.8 Bulk Erase

The Bulk Erase (BE) command erases the entire contents of flash memory, ignoring any protected sectors or flash security. Flash security is disabled upon successful completion of the BE command.

Attempts to issue a BE command while the BEDIS and FS bits are set results in the WEF flag being set in the EzPort status register. Also, this command is not accepted if the WEF or WIP bit is set or if the WEN bit is not set in the EzPort status register.

29.3.1.9 EzPort Reset Chip

The Reset Chip (RESET) command forces the chip into the reset state. If the EzPort chip select ($\overline{\text{EZP_CS}}$) pin is asserted at the end of the reset period then EzPort is enabled; otherwise, it is disabled. This command allows the chip to boot up from flash memory after it has been programmed by an external source.

This command is not accepted if the WIP bit is set in the EzPort status register.

29.3.1.10 Write FCCOB Registers

The Write FCCOB Registers (WRFCCOB) command allows the user to write to the flash common command object registers and execute any command allowed by the flash.

NOTE

The flash is configured in NVM special mode, restricting which commands can be executed by the flash when security is enabled.

After receiving 12 bytes of data, EzPort writes the data to the FCCOB 0-B registers in the flash and then automatically launches the command within the flash. If greater or less than 12 bytes of data is received, this command has unexpected results and may result in the WEF flag being set.

This command is not accepted if the WEF or WIP bit is set or if the WEN bit is not set in the EzPort status register.

29.3.1.11 Read FCCOB Registers at High Speed

The Read FCCOB Registers at High Speed (FAST_RDFCCOB) command allows the user to read the contents of the flash common command object registers. After receiving the command, EzPort waits for one dummy byte of data before returning FCCOB register data starting at FCCOB 0 and ending with FCCOB B.

This command can be run with an EzPort clock (EZP_CK) frequency half the internal system clock frequency of the micro-controller or slower. Attempts to read greater than 12 bytes of data returns junk data. This command is not be accepted if the WEF, WIP, or FS bit in the EzPort status register is set.

29.4 Flash Memory Map for EzPort Access

The following table shows the flash memory map for access through EzPort.

NOTE

The flash block address map for access through EzPort may not conform to the system memory map. Changes are made to allow the EzPort address width to remain at 24-bits.

Table 29-5. Flash Memory Map for EzPort Access

Valid Start Address	Size	Flash block	Valid Commands
0x0000_0000	See device's Chip Configuration details	Flash	READ, FAST_READ, SP, SE, BE

Chapter 30

Cyclic redundancy check (CRC)

30.1 Introduction

NOTE

For the chip-specific implementation details of this module's instances see the chip configuration chapter.

The cyclic redundancy check (CRC) module generates 16/32-bit CRC code for error detection.

The CRC module provides a programmable polynomial, WAS, and other parameters required to implement a 16-bit or 32-bit CRC standard.

The 16/32-bit code is calculated for 32 bits of data at a time.

30.1.1 Features

Features of the CRC module include:

- Hardware CRC generator circuit using a 16-bit or 32-bit (programmable) shift register.
- Programmable initial seed value and polynomial.
- Option to transpose input data or output data (the CRC result) bitwise or byte-wise. This option is required for certain CRC standards. A byte-wise transpose operation is not possible when accessing the CRC data register via 8-bit accesses. In this case, the user's software must perform the byte-wise transpose function.
- Option for inversion of final CRC result.
- 32-bit CPU register programming interface.

30.1.2 Block diagram

This is a block diagram of the CRC.

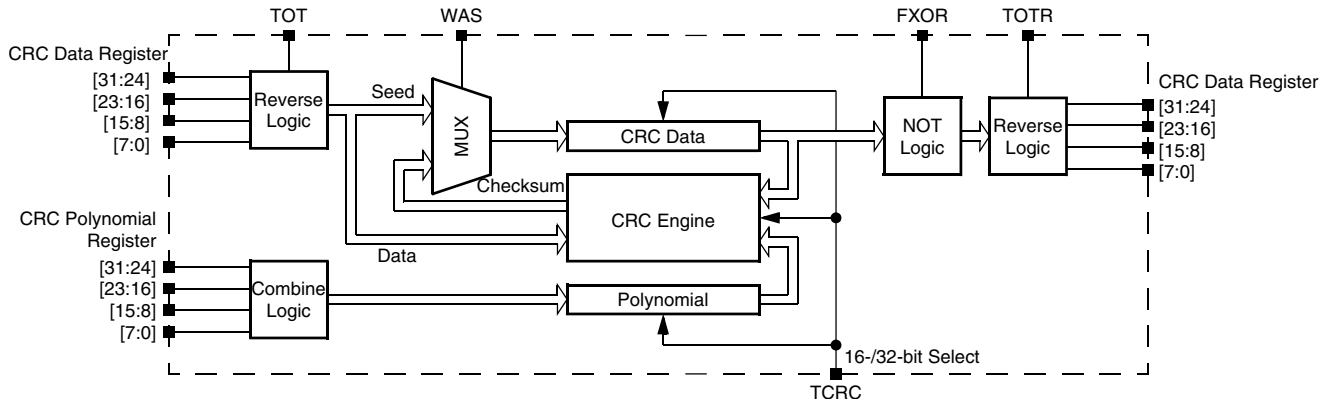

Figure 30-1. Programmable cyclic redundancy check (CRC) block diagram

30.1.3 Modes of operation

Various MCU modes affect the CRC module's functionality.

30.1.3.1 Run mode

This is the basic mode of operation.

30.1.3.2 Low power modes (wait or stop)

Any CRC calculation in progress stops when the MCU enters a low power mode that disables the module clock. It resumes after the clock is enabled or via the system reset for exiting the low power mode. Clock gating for this module is MCU dependent.

30.2 Memory map and register descriptions

CRC memory map

Absolute address (hex)	Register name	Width (in bits)	Access	Reset value	Section/page
4003_2000	CRC Data Register (CRC_CRC)	32	R/W	FFFF_FFFFh	30.2.1/ 659
4003_2004	CRC Polynomial Register (CRC_GPOLY)	32	R/W	0000_1021h	30.2.2/ 660
4003_2008	CRC Control Register (CRC_CTRL)	32	R/W	0000_0000h	30.2.3/ 661

30.2.1 CRC Data Register (CRC_CRC)

The CRC data register contains the value of the seed, data, and checksum. When the CTRL[WAS] bit is set, any write to the data register is regarded as the seed value. When the CTRL[WAS] bit is cleared, any write to the data register is regarded as data for general CRC computation.

In 16-bit CRC mode, the HU and HL fields are not used for programming the seed value, and reads of these fields return an indeterminate value. In 32-bit CRC mode, all fields are used for programming the seed value.

When programming data values, the values can be written 8 bits, 16 bits, or 32 bits at a time, provided all bytes are contiguous; with MSB of data value written first.

After all data values are written, the CRC result can be read from this data register. In 16-bit CRC mode, the CRC result is available in the LU and LL fields. In 32-bit CRC mode, all fields contain the result. Reads of this register at any time return the intermediate CRC value, provided the CRC module is configured.

Address: CRC_CRC is 4003_2000h base + 0h offset = 4003_2000h

Bit	31	30	29	28	27	26	25	24	23	22	21	20	19	18	17	16	15	14	13	12	11	10	9	8	7	6	5	4	3	2	1	0
R	HU								HL								LU								LL							
W																																
Reset	1	1	1	1	1	1	1	1	1	1	1	1	1	1	1	1	1	1	1	1	1	1	1	1	1	1	1	1	1	1	1	1

CRC_CRC field descriptions

Field	Description
31–24 HU	CRC High Upper Byte In 16-bit CRC mode (the CTRL[TCRC] bit is 0), this field is not used for programming a seed value. In 32-bit CRC mode (the CTRL[TCRC] bit is 1), values written to this field are part of the seed value when the CTRL[WAS] bit is 1. When the CTRL[WAS] bit is 0, data written to this field is used for CRC checksum generation in both 16-bit and 32-bit CRC modes.

Table continues on the next page...

CRC_CRC field descriptions (continued)

Field	Description
23–16 HL	CRC High Lower Byte In 16-bit CRC mode (the CTRL[TCRC] bit is 0), this field is not used for programming a seed value. In 32-bit CRC mode (the CTRL[TCRC] bit is 1), values written to this field are part of the seed value when the CTRL[WAS] bit is 1. When the CTRL[WAS] bit is 0, data written to this field is used for CRC checksum generation in both 16-bit and 32-bit CRC modes.
15–8 LU	CRC Low Upper Byte When the CTRL[WAS] bit is 1, values written to this field are part of the seed value. When the CTRL[WAS] bit is 0, data written to this field is used for CRC checksum generation.
7–0 LL	CRC Low Lower Byte When the CTRL[WAS] bit is 1, values written to this field are part of the seed value. When the CTRL[WAS] bit is 0, data written to this field is used for CRC checksum generation.

30.2.2 CRC Polynomial Register (CRC_GPOLY)

This register contains the value of the polynomial for the CRC calculation. The HIGH field contains the upper 16 bits of the CRC polynomial, which are used only in 32-bit CRC mode. Writes to the HIGH field are ignored in 16-bit CRC mode. The LOW field contains the lower 16 bits of the CRC polynomial, which are used in both 16- and 32-bit CRC modes.

Address: CRC_GPOLY is 4003_2000h base + 4h offset = 4003_2004h

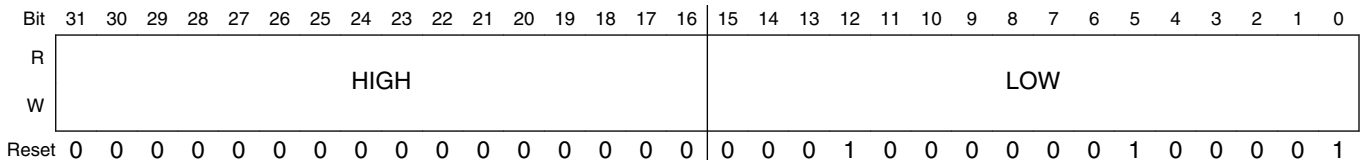

CRC_GPOLY field descriptions

Field	Description
31–16 HIGH	High polynomial half-word This field is writable and readable in 32-bit CRC mode (the CTRL[TCRC] bit is 1). This field is not writable in 16-bit CRC mode (the CTRL[TCRC] bit is 0).
15–0 LOW	Low polynomial half-word This field is writable and readable in both 32-bit and 16-bit CRC modes.

30.2.3 CRC Control Register (CRC_CTRL)

This register controls the configuration and working of the CRC module. Appropriate bits must be set before starting a new CRC calculation. A new CRC calculation is initialized by asserting the CTRL[WAS] bit and then writing the seed into the CRC data register.

Address: CRC_CTRL is 4003_2000h base + 8h offset = 4003_2008h

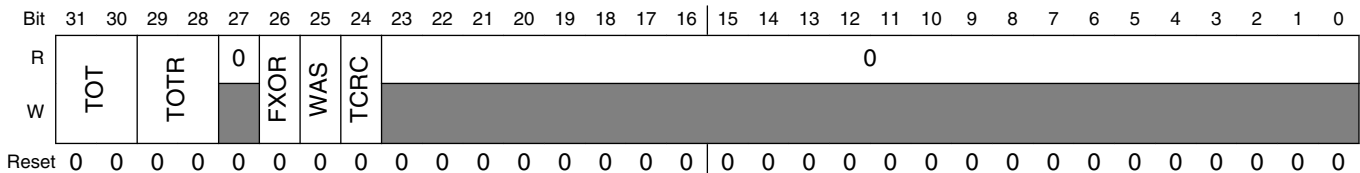

CRC_CTRL field descriptions

Field	Description
31–30 TOT	Type of Transpose for Writes These bits define the transpose configuration of the data written to the CRC data register. Refer to the description of the transpose feature for the available transpose options. 00 No transposition. 01 Bits in bytes are transposed; bytes are not transposed. 10 Both bits in bytes and bytes are transposed. 11 Only bytes are transposed; no bits in a byte are transposed.
29–28 TOTR	Type of Transpose for Read These bits identify the transpose configuration of the value read from the CRC data register. Refer to the description of the transpose feature for the available transpose options. 00 No transposition. 01 Bits in bytes are transposed; bytes are not transposed. 10 Both bits in bytes and bytes are transposed. 11 Only bytes are transposed; no bits in a byte are transposed.
27 Reserved	This read-only field is reserved and always has the value zero.
26 FXOR	Complement Read of CRC data register Some CRC protocols require the final checksum to be XORed with 0xFFFFFFFF or 0xFFFF. Asserting this bit enables "on the fly" complementing of read data. 0 No XOR on reading. 1 Invert or complement the read value of the CRC data register.
25 WAS	Write CRC data register as seed When this bit is asserted, a value written to the CRC data register is considered a seed value. When this bit is de-asserted, a value written to the CRC data register is taken as data for CRC computation. 0 Writes to the CRC data register are data values. 1 Writes to the CRC data register are seed values.

Table continues on the next page...

CRC_CTRL field descriptions (continued)

Field	Description
24 TCRC	Width of CRC protocol. 0 16-bit CRC protocol. 1 32-bit CRC protocol.
23–0 Reserved	This read-only field is reserved and always has the value zero.

30.3 Functional description

30.3.1 CRC initialization/re-initialization

To enable the CRC calculation, the user must program the WAS, POLYNOMIAL, and necessary parameters for transpose and CRC result inversion in the applicable registers. Asserting the CTRL[WAS] bit enables the programming of the seed value into the CRC data register.

After a completed CRC calculation, re-asserting the CTRL[WAS] bit and programming a seed (whether the value is new or a previously used seed value) re-initialize the CRC module for a new CRC computation. All other parameters must be set before programming the seed value and subsequent data values.

30.3.2 CRC calculations

In 16-bit and 32-bit CRC modes, data values can be programmed 8 bits, 16 bits, or 32 bits at a time, provided all bytes are contiguous. Non-contiguous bytes can lead to an incorrect CRC computation.

30.3.2.1 16-bit CRC

Compute a 16-bit CRC with the following steps:

1. Clear the CTRL[TCRC] bit to enable 16-bit CRC mode.
2. Program the transpose and complement options in the CTRL register as required for the CRC calculation. See [Transpose feature](#) and [CRC result complement](#) for details.
3. Write a 16-bit polynomial to the GPOLY[LOW] field. The GPOLY[HIGH] field is not usable in 16-bit CRC mode.
4. Set the CTRL[WAS] bit to program the seed value.

5. Write a 16-bit seed to CRC[LU:LL]. CRC[HU:HL] are not used.
6. Clear the CTRL[WAS] bit to start writing data values.
7. Write data values into CRC[HU:HL:LU:LL]. A CRC is computed on every data value write, and the intermediate CRC result is stored back into CRC[LU:LL].
8. When all values have been written, read the final CRC result from CRC[LU:LL].

Transpose and complement operations are performed "on the fly" while reading or writing values. See [Transpose feature](#) and [CRC result complement](#) for details.

30.3.2.2 32-bit CRC

Compute a 32-bit CRC with the following steps:

1. Set the CTRL[TCRC] bit to enable 32-bit CRC mode.
2. Program the transpose and complement options in the CTRL register as required for the CRC calculation. See [Transpose feature](#) and [CRC result complement](#) for details.
3. Write a 32-bit polynomial to GPOLY[HIGH:LOW].
4. Set the CTRL[WAS] bit to program the seed value.
5. Write a 32-bit seed to CRC[HU:HL:LU:LL].
6. Clear the CTRL[WAS] bit to start writing data values.
7. Write data values into CRC[HU:HL:LU:LL]. A CRC is computed on every data value write, and the intermediate CRC result is stored back into CRC[HU:HL:LU:LL].
8. When all values have been written, read the final CRC result from CRC[HU:HL:LU:LL]. The CRC is calculated byte-wise, and two clocks are required to complete one CRC calculation.

Transpose and complement operations are performed "on the fly" while reading or writing values. See [Transpose feature](#) and [CRC result complement](#) for details.

30.3.3 Transpose feature

By default, the transpose feature is not enabled. However, some CRC standards require the input data and/or the final checksum to be transposed. The user software has the option to configure each transpose operation separately, as desired by the CRC standard. The data is transposed "on the fly" while being read or written.

Some protocols use little endian format for the data stream to calculate a CRC. In this case, the transpose feature usefully flips the bits. This transpose option is one of the types supported by the CRC module.

30.3.3.1 Types of transpose

The CRC module provides several types of transpose functions to flip the bits and/or bytes (for both writing input data and reading the CRC result, separately using the CTRL[TOT] or CTRL[TOTR] fields) according to the CRC calculation being used.

The following types of transpose functions are available for writing to and reading from the CRC data register.

1. CTRL[TOT] or CTRL[TOTR] is 00

No transposition occurs.

2. CTRL[TOT] or CTRL[TOTR] is 01

Bits in a byte are transposed, while bytes are not transposed.

reg[31:0] becomes {reg[24:31], reg[16:23], reg[8:15], reg[0:7]}

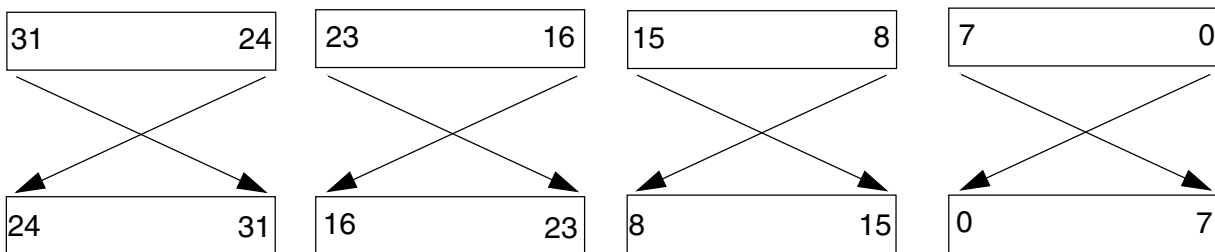

Figure 30-5. Transpose type 01

3. CTRL[TOT] or CTRL[TOTR] is 10

Both bits in bytes and bytes are transposed.

reg[31:0] becomes = {reg[0:7], reg[8:15], reg[16:23], reg[24:31]}

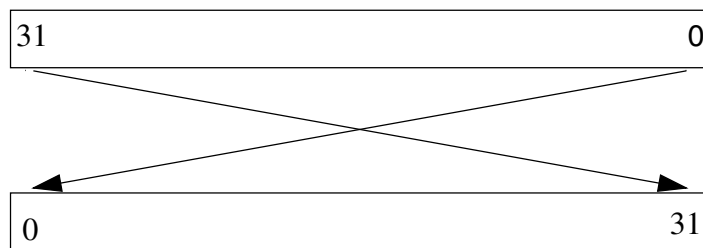

Figure 30-6. Transpose type 10

4. CTRL[TOT] or CTRL[TOTR] is 11

Bytes are transposed, but bits are not transposed.

reg[31:0] becomes {reg[7:0], reg[15:8], reg[23:16], reg[31:24]}

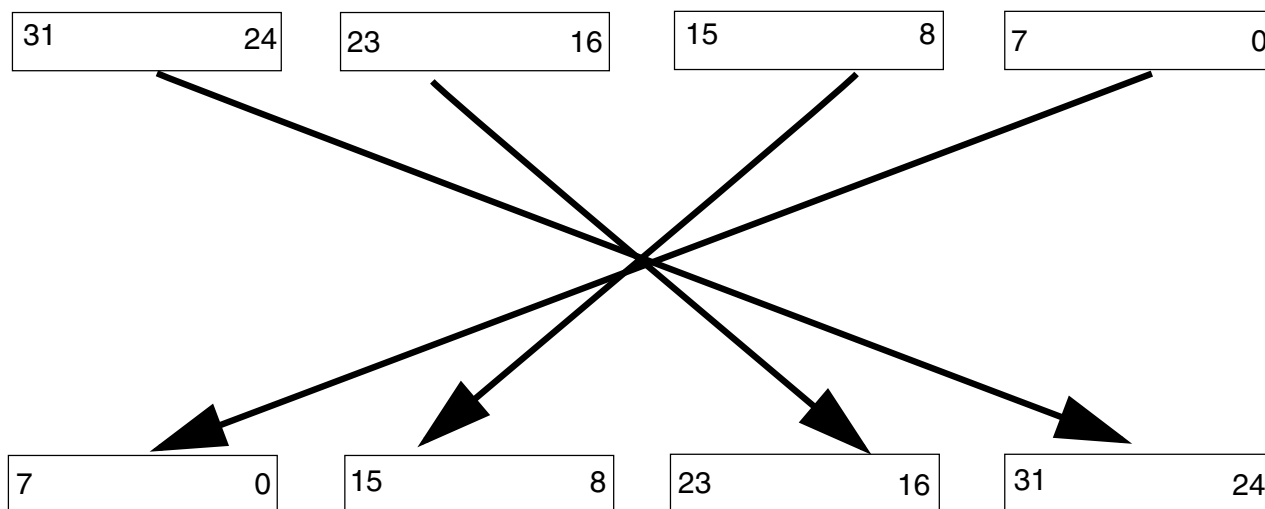

Figure 30-7. Transpose type 11

NOTE

For 8-bit and 16-bit write accesses to the CRC data register, the data is transposed with zeros on the unused byte or bytes (taking 32 bits as a whole), but the CRC is calculated on the valid byte(s) only. When reading the CRC data register for a 16-bit CRC result and using transpose options 10 and 11, the resulting value after transposition resides in the CRC[*HU*:*HL*] fields. The user software must account for this situation when reading the 16-bit CRC result, so reading 32 bits is preferred.

30.3.4 CRC result complement

When the CTRL[*FXOR*] bit is set, the checksum is complemented: The CRC result complement function outputs the complement of the checksum value stored in the CRC data register every time the CRC data register is read. When the CTRL[*FXOR*] bit is cleared, reading the CRC data register accesses the raw checksum value.



Chapter 31

Analog-to-Digital Converter (ADC)

31.1 Introduction

NOTE

For the chip-specific implementation details of this module's instances see the chip configuration chapter.

The 16-bit analog-to-digital converter (ADC) is a successive approximation ADC designed for operation within an integrated microcontroller system-on-chip.

NOTE

For the chip specific modes of operation, refer to the Power Management information for the device.

31.1.1 Features

Features of the ADC module include:

- Linear successive approximation algorithm with up to 16-bit resolution
- Up to 4 pairs of differential and 24 single-ended external analog inputs
- Output modes: differential 16-bit, 13-bit, 11-bit and 9-bit modes, or single-ended 16-bit, 12-bit, 10-bit and 8-bit modes
- Output formatted in 2's complement 16-bit sign extended for differential modes
- Output in right-justified unsigned format for single-ended
- Single or continuous conversion (automatic return to idle after single conversion)
- Configurable sample time and conversion speed/power
- Conversion complete / hardware average complete flag and interrupt

- Input clock selectable from up to four sources
- Operation in low power modes for lower noise operation
- Asynchronous clock source for lower noise operation with option to output the clock
- Selectable hardware conversion trigger with hardware channel select
- Automatic compare with interrupt for less-than, greater-than or equal-to, within range, or out-of-range, programmable value
- Temperature sensor
- Hardware average function
- Selectable voltage reference: external or alternate
- Self-calibration mode
- Programmable Gain Amplifier (PGA) with up to x64 gain

31.1.2 Block diagram

The following figure is the ADC module block diagram.

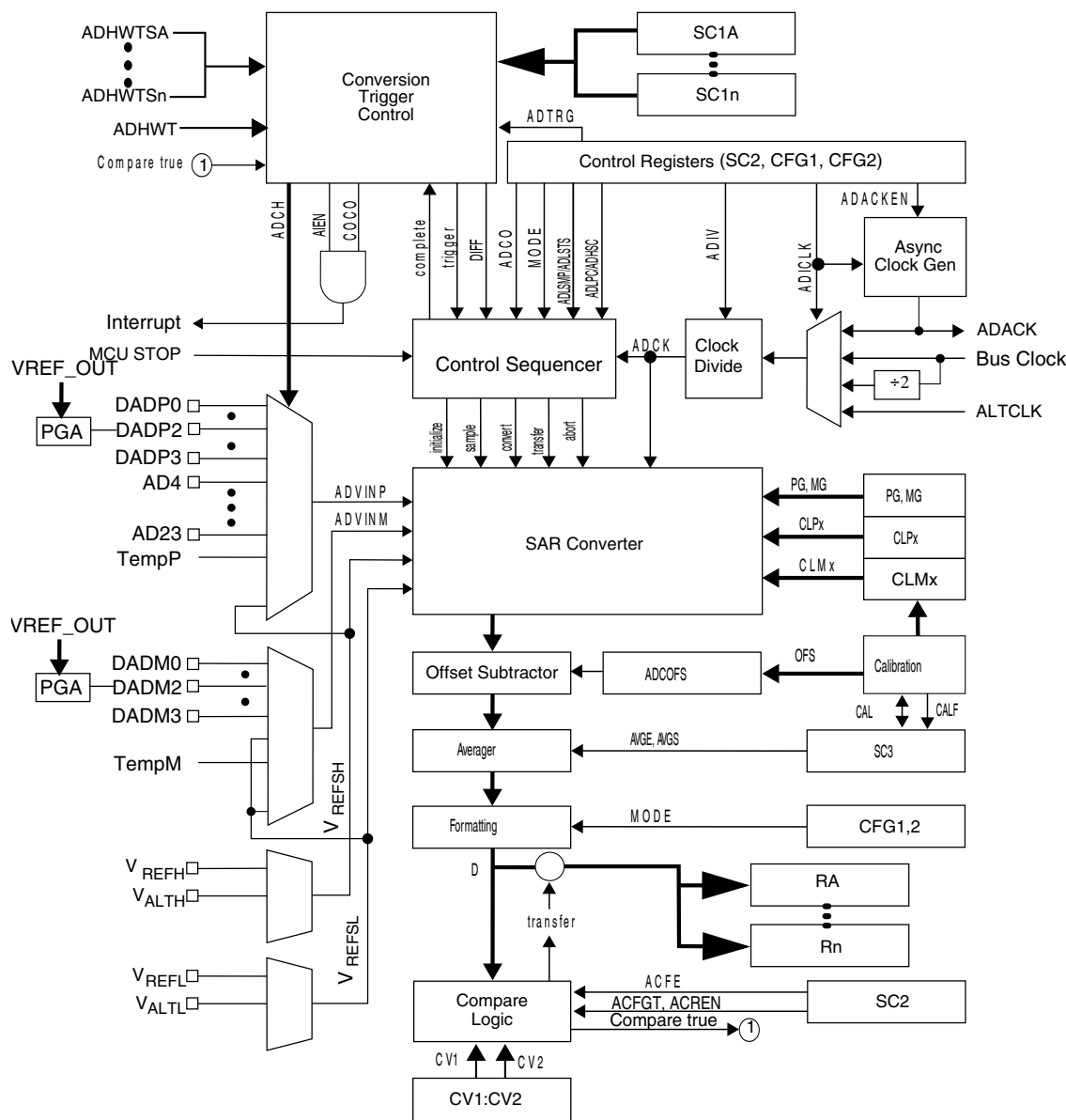

Figure 31-1. ADC block diagram

31.2 ADC Signal Descriptions

The ADC module supports up to 4 pairs of differential inputs and up to 24 single-ended inputs. Each differential pair requires two inputs, DADPx and DADMx. The ADC also requires four supply/reference/ground connections.

Table 31-1. ADC Signal Descriptions

Signal	Description	I/O
DADP[3:0]	Differential analog channel inputs	I

Table continues on the next page...

Table 31-1. ADC Signal Descriptions (continued)

Signal	Description	I/O
DADM[3:0]	Differential analog channel inputs	I
AD[23:4]	Single-ended analog channel inputs	I
V _{REFSH}	Voltage reference select high	I
V _{REFSL}	Voltage reference select low	I
V _{DDA}	Analog power supply	I
V _{SSA}	Analog ground	I

31.2.1 Analog power (V_{DDA})

The ADC analog portion uses V_{DDA} as its power connection. In some packages, V_{DDA} is connected internally to V_{DD}. If externally available, connect the V_{DDA} pin to the same voltage potential as V_{DD}. External filtering may be necessary to ensure clean V_{DDA} for good results.

31.2.2 Analog ground (V_{SSA})

The ADC analog portion uses V_{SSA} as its ground connection. In some packages, V_{SSA} is connected internally to V_{SS}. If externally available, connect the V_{SSA} pin to the same voltage potential as V_{SS}.

31.2.3 Voltage reference select

V_{REFSH} and V_{REFSL} are the high and low reference voltages for the converter.

The ADC can be configured to accept one of two voltage reference pairs for V_{REFSH} and V_{REFSL}. Each pair contains a positive reference that must be between the minimum Ref Voltage High and V_{DDA}, and a ground reference that must be at the same potential as V_{SSA}. The two pairs are external (V_{REFH} and V_{REFL}) and alternate (V_{ALTH} and V_{ALTL}). These voltage references are selected using the REFSEL bits in the SC2 register. The alternate (V_{ALTH} and V_{ALTL}) voltage reference pair may select additional external pins or internal sources depending on MCU configuration. Refer to the Chip Configuration information on the Voltage References specific to this MCU.

In some packages, V_{REFH} is connected in the package to V_{DDA} and V_{REFL} to V_{SSA} . If externally available, the positive reference(s) may be connected to the same potential as V_{DDA} or may be driven by an external source to a level between the minimum Ref Voltage High and the V_{DDA} potential (V_{REFH} must never exceed V_{DDA}). Connect the ground references to the same voltage potential as V_{SSA} .

31.2.4 Analog channel inputs (ADx)

The ADC module supports up to 24 single-ended analog inputs. A single-ended input is selected for conversion through the ADCH channel select bits when the DIFF bit in the SC1n register is low.

31.2.5 Differential analog channel inputs (DADx)

The ADC module supports up to 4 differential analog channel inputs. Each differential analog input is a pair of external pins (DADPx and DADMx) referenced to each other to provide the most accurate analog to digital readings. A differential input is selected for conversion through the ADCH channel select bits when the DIFF bit in the SC1n register bit is high. All DADPx inputs may be used as single-ended inputs if the DIFF bit is low. In certain MCU configurations, some DADMx inputs may also be used as single-ended inputs if the DIFF bit is low. Refer to the Chip Configuration chapter for ADC connections specific to this MCU.

31.3 Register Definition

This section describes the ADC registers.

ADC memory map

Absolute address (hex)	Register name	Width (in bits)	Access	Reset value	Section/page
4003_B000	ADC status and control registers 1 (ADC0_SC1A)	32	R/W	0000_001Fh	31.3.1/674
4003_B004	ADC status and control registers 1 (ADC0_SC1B)	32	R/W	0000_001Fh	31.3.1/674
4003_B008	ADC configuration register 1 (ADC0_CFG1)	32	R/W	0000_0000h	31.3.2/677

Table continues on the next page...

ADC memory map (continued)

Absolute address (hex)	Register name	Width (in bits)	Access	Reset value	Section/page
4003_B00C	Configuration register 2 (ADC0_CFG2)	32	R/W	0000_0000h	31.3.3/ 679
4003_B010	ADC data result register (ADC0_RA)	32	R	0000_0000h	31.3.4/ 680
4003_B014	ADC data result register (ADC0_RB)	32	R	0000_0000h	31.3.4/ 680
4003_B018	Compare value registers (ADC0_CV1)	32	R/W	0000_0000h	31.3.5/ 681
4003_B01C	Compare value registers (ADC0_CV2)	32	R/W	0000_0000h	31.3.5/ 681
4003_B020	Status and control register 2 (ADC0_SC2)	32	R/W	0000_0000h	31.3.6/ 682
4003_B024	Status and control register 3 (ADC0_SC3)	32	R/W	0000_0000h	31.3.7/ 684
4003_B028	ADC offset correction register (ADC0_OFS)	32	R/W	0000_0004h	31.3.8/ 685
4003_B02C	ADC plus-side gain register (ADC0_PG)	32	R/W	0000_8200h	31.3.9/ 686
4003_B030	ADC minus-side gain register (ADC0_MG)	32	R/W	0000_8200h	31.3.10/ 686
4003_B034	ADC plus-side general calibration value register (ADC0_CLPD)	32	R/W	0000_000Ah	31.3.11/ 687
4003_B038	ADC plus-side general calibration value register (ADC0_CLPS)	32	R/W	0000_0020h	31.3.12/ 688
4003_B03C	ADC plus-side general calibration value register (ADC0_CLP4)	32	R/W	0000_0200h	31.3.13/ 688
4003_B040	ADC plus-side general calibration value register (ADC0_CLP3)	32	R/W	0000_0100h	31.3.14/ 689
4003_B044	ADC plus-side general calibration value register (ADC0_CLP2)	32	R/W	0000_0080h	31.3.15/ 689
4003_B048	ADC plus-side general calibration value register (ADC0_CLP1)	32	R/W	0000_0040h	31.3.16/ 690
4003_B04C	ADC plus-side general calibration value register (ADC0_CLP0)	32	R/W	0000_0020h	31.3.17/ 690
4003_B050	ADC PGA register (ADC0_PGA)	32	R/W	0000_0000h	31.3.18/ 691
4003_B054	ADC minus-side general calibration value register (ADC0_CLMD)	32	R/W	0000_000Ah	31.3.19/ 692
4003_B058	ADC minus-side general calibration value register (ADC0_CLMS)	32	R/W	0000_0020h	31.3.20/ 693

Table continues on the next page...

ADC memory map (continued)

Absolute address (hex)	Register name	Width (in bits)	Access	Reset value	Section/page
4003_B05C	ADC minus-side general calibration value register (ADC0_CLM4)	32	R/W	0000_0200h	31.3.21/ 693
4003_B060	ADC minus-side general calibration value register (ADC0_CLM3)	32	R/W	0000_0100h	31.3.22/ 694
4003_B064	ADC minus-side general calibration value register (ADC0_CLM2)	32	R/W	0000_0080h	31.3.23/ 694
4003_B068	ADC minus-side general calibration value register (ADC0_CLM1)	32	R/W	0000_0040h	31.3.24/ 695
4003_B06C	ADC minus-side general calibration value register (ADC0_CLM0)	32	R/W	0000_0020h	31.3.25/ 695
400B_B000	ADC status and control registers 1 (ADC1_SC1A)	32	R/W	0000_001Fh	31.3.1/ 674
400B_B004	ADC status and control registers 1 (ADC1_SC1B)	32	R/W	0000_001Fh	31.3.1/ 674
400B_B008	ADC configuration register 1 (ADC1_CFG1)	32	R/W	0000_0000h	31.3.2/ 677
400B_B00C	Configuration register 2 (ADC1_CFG2)	32	R/W	0000_0000h	31.3.3/ 679
400B_B010	ADC data result register (ADC1_RA)	32	R	0000_0000h	31.3.4/ 680
400B_B014	ADC data result register (ADC1_RB)	32	R	0000_0000h	31.3.4/ 680
400B_B018	Compare value registers (ADC1_CV1)	32	R/W	0000_0000h	31.3.5/ 681
400B_B01C	Compare value registers (ADC1_CV2)	32	R/W	0000_0000h	31.3.5/ 681
400B_B020	Status and control register 2 (ADC1_SC2)	32	R/W	0000_0000h	31.3.6/ 682
400B_B024	Status and control register 3 (ADC1_SC3)	32	R/W	0000_0000h	31.3.7/ 684
400B_B028	ADC offset correction register (ADC1_OFS)	32	R/W	0000_0004h	31.3.8/ 685
400B_B02C	ADC plus-side gain register (ADC1_PG)	32	R/W	0000_8200h	31.3.9/ 686
400B_B030	ADC minus-side gain register (ADC1_MG)	32	R/W	0000_8200h	31.3.10/ 686
400B_B034	ADC plus-side general calibration value register (ADC1_CLPD)	32	R/W	0000_000Ah	31.3.11/ 687
400B_B038	ADC plus-side general calibration value register (ADC1_CLPS)	32	R/W	0000_0020h	31.3.12/ 688

Table continues on the next page...

ADC memory map (continued)

Absolute address (hex)	Register name	Width (in bits)	Access	Reset value	Section/page
400B_B03C	ADC plus-side general calibration value register (ADC1_CLP4)	32	R/W	0000_0200h	31.3.13/ 688
400B_B040	ADC plus-side general calibration value register (ADC1_CLP3)	32	R/W	0000_0100h	31.3.14/ 689
400B_B044	ADC plus-side general calibration value register (ADC1_CLP2)	32	R/W	0000_0080h	31.3.15/ 689
400B_B048	ADC plus-side general calibration value register (ADC1_CLP1)	32	R/W	0000_0040h	31.3.16/ 690
400B_B04C	ADC plus-side general calibration value register (ADC1_CLP0)	32	R/W	0000_0020h	31.3.17/ 690
400B_B050	ADC PGA register (ADC1_PGA)	32	R/W	0000_0000h	31.3.18/ 691
400B_B054	ADC minus-side general calibration value register (ADC1_CLMD)	32	R/W	0000_000Ah	31.3.19/ 692
400B_B058	ADC minus-side general calibration value register (ADC1_CLMS)	32	R/W	0000_0020h	31.3.20/ 693
400B_B05C	ADC minus-side general calibration value register (ADC1_CLM4)	32	R/W	0000_0200h	31.3.21/ 693
400B_B060	ADC minus-side general calibration value register (ADC1_CLM3)	32	R/W	0000_0100h	31.3.22/ 694
400B_B064	ADC minus-side general calibration value register (ADC1_CLM2)	32	R/W	0000_0080h	31.3.23/ 694
400B_B068	ADC minus-side general calibration value register (ADC1_CLM1)	32	R/W	0000_0040h	31.3.24/ 695
400B_B06C	ADC minus-side general calibration value register (ADC1_CLM0)	32	R/W	0000_0020h	31.3.25/ 695

31.3.1 ADC status and control registers 1 (ADCx_SC1n)

The SC1A register is used for both software and hardware trigger modes of operation.

To allow sequential conversions of the ADC to be triggered by internal peripherals, the ADC can have more than one status and control register: one for each conversion. The SC1B-SC1n registers indicate potentially multiple SC1 registers for use only in hardware trigger mode. Refer to the Chip Configuration information about the number of SC1n registers specific to this device. The SC1n registers have identical fields, and are used in a "ping-pong" approach to control ADC operation.

At any one point in time, only one of the SC1n registers is actively controlling ADC conversions. Updating SC1A while SC1n is actively controlling a conversion is allowed (and vice-versa for any of the SC1n registers specific to this MCU).

Writing SC1A while SC1A is actively controlling a conversion aborts the current conversion. In software trigger mode (ADTRG=0), writes to the SC1A register subsequently initiate a new conversion (if the ADCH bits are equal to a value other than all 1s).

Similarly, writing any of the SC1n registers while that specific SC1n register is actively controlling a conversion aborts the current conversion. None of the SC1B-SC1n registers are used for software trigger operation and therefore writes to the SC1B - SC1n registers do not initiate a new conversion.

Addresses: ADC0_SC1A is 4003_B000h base + 0h offset = 4003_B000h

ADC0_SC1B is 4003_B000h base + 4h offset = 4003_B004h

ADC1_SC1A is 400B_B000h base + 0h offset = 400B_B000h

ADC1_SC1B is 400B_B000h base + 4h offset = 400B_B004h

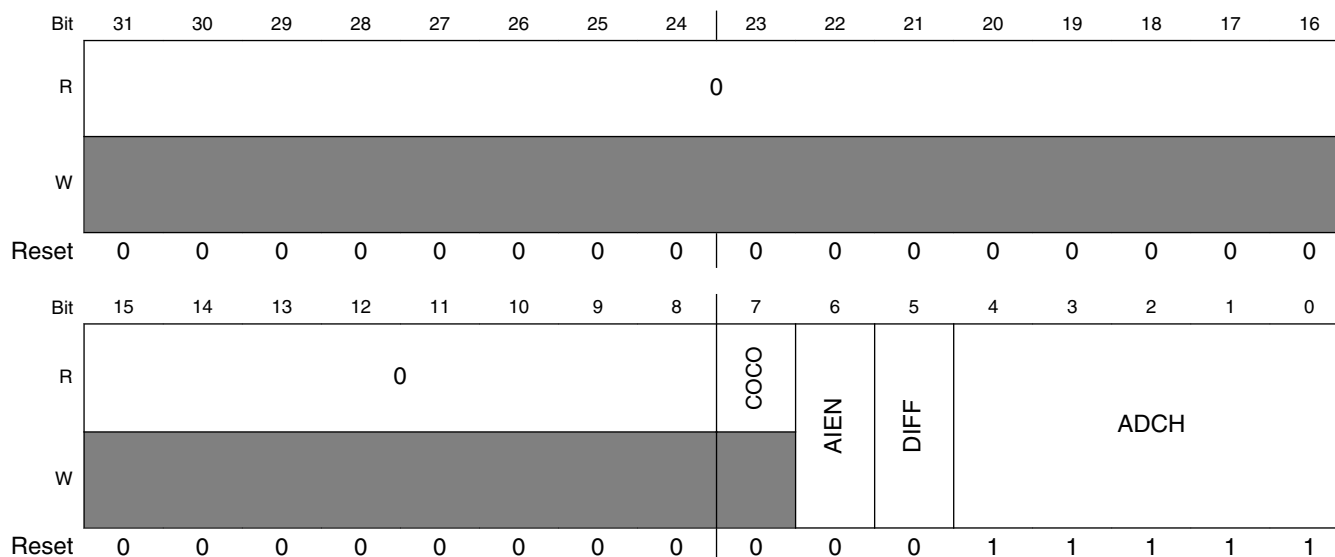

ADCx_SC1n field descriptions

Field	Description
31–8 Reserved	This read-only field is reserved and always has the value zero.
7 COCO	<p>Conversion complete flag</p> <p>The COCO flag is a read-only bit that is set each time a conversion is completed when the compare function is disabled (ACFE=0) and the hardware average function is disabled (AVGE=0). When the compare function is enabled (ACFE=1), the COCO flag is set upon completion of a conversion only if the compare result is true. When the hardware average function is enabled (AVGE=1), the COCO flag is set upon completion of the selected number of conversions (determined by the AVGS bits). The COCO flag in SC1A is also set at the completion of a Calibration sequence. The COCO bit is cleared when the respective SC1n register is written or when the respective Rn register is read.</p> <p>0 Conversion not completed. 1 Conversion completed.</p>

Table continues on the next page...

ADCx_SC1n field descriptions (continued)

Field	Description
6 AIEN	<p>Interrupt enable</p> <p>AIEN enables conversion complete interrupts. When COCO becomes set while the respective AIEN is high, an interrupt is asserted.</p> <p>0 Conversion complete interrupt disabled. 1 Conversion complete interrupt enabled.</p>
5 DIFF	<p>Differential mode enable</p> <p>DIFF configures the ADC to operate in differential mode. When enabled, this mode automatically selects from the differential channels, and changes the conversion algorithm and the number of cycles to complete a conversion.</p> <p>0 Single-ended conversions and input channels are selected. 1 Differential conversions and input channels are selected.</p>
4–0 ADCH	<p>Input channel select</p> <p>The ADCH bits form a 5-bit field that selects one of the input channels. The input channel decode depends on the value of the DIFF bit. DAD0-DAD3 are associated with the input pin pairs DADPx and DADMx.</p> <p>The successive approximation converter subsystem is turned off when the channel select bits are all set (ADCH = 11111). This feature allows for explicit disabling of the ADC and isolation of the input channel from all sources. Terminating continuous conversions this way prevents an additional single conversion from being performed. It is not necessary to set the channel select bits to all ones to place the ADC in a low-power state when continuous conversions are not enabled because the module automatically enters a low-power state when a conversion completes.</p> <p>00000 When DIFF=0, DADP0 is selected as input; when DIFF=1, DAD0 is selected as input. 00001 When DIFF=0, DADP1 is selected as input; when DIFF=1, DAD1 is selected as input. 00010 When DIFF=0, DADP2 is selected as input; when DIFF=1, DAD2 is selected as input. 00011 When DIFF=0, DADP3 is selected as input; when DIFF=1, DAD3 is selected as input. 00100 When DIFF=0, AD4 is selected as input; when DIFF=1, it is reserved. 00101 When DIFF=0, AD5 is selected as input; when DIFF=1, it is reserved. 00110 When DIFF=0, AD6 is selected as input; when DIFF=1, it is reserved. 00111 When DIFF=0, AD7 is selected as input; when DIFF=1, it is reserved. 01000 When DIFF=0, AD8 is selected as input; when DIFF=1, it is reserved. 01001 When DIFF=0, AD9 is selected as input; when DIFF=1, it is reserved. 01010 When DIFF=0, AD10 is selected as input; when DIFF=1, it is reserved. 01011 When DIFF=0, AD11 is selected as input; when DIFF=1, it is reserved. 01100 When DIFF=0, AD12 is selected as input; when DIFF=1, it is reserved. 01101 When DIFF=0, AD13 is selected as input; when DIFF=1, it is reserved. 01110 When DIFF=0, AD14 is selected as input; when DIFF=1, it is reserved. 01111 When DIFF=0, AD15 is selected as input; when DIFF=1, it is reserved. 10000 When DIFF=0, AD16 is selected as input; when DIFF=1, it is reserved. 10001 When DIFF=0, AD17 is selected as input; when DIFF=1, it is reserved. 10010 When DIFF=0, AD18 is selected as input; when DIFF=1, it is reserved. 10011 When DIFF=0, AD19 is selected as input; when DIFF=1, it is reserved. 10100 When DIFF=0, AD20 is selected as input; when DIFF=1, it is reserved. 10101 When DIFF=0, AD21 is selected as input; when DIFF=1, it is reserved. 10110 When DIFF=0, AD22 is selected as input; when DIFF=1, it is reserved.</p>

Table continues on the next page...

ADCx_SC1n field descriptions (continued)

Field	Description
10111	When DIFF=0, AD23 is selected as input; when DIFF=1, it is reserved.
11000	Reserved.
11001	Reserved.
11010	When DIFF=0, Temp sensor (single-ended) is selected as input; when DIFF=1, Temp sensor (differential) is selected as input.
11011	When DIFF=0, Bandgap (single-ended) is selected as input; when DIFF=1, Bandgap (differential) is selected as input.
11100	Reserved.
11101	When DIFF=0, V _{REFSH} is selected as input; when DIFF=1, -V _{REFSH} (differential) is selected as input. Voltage reference selected is determined by the REFSEL bits in the SC2 register.
11110	When DIFF=0, V _{REFSL} is selected as input; when DIFF=1, it is reserved. Voltage reference selected is determined by the REFSEL bits in the SC2 register.
11111	Module disabled.

31.3.2 ADC configuration register 1 (ADCx_CFG1)

CFG1 register selects the mode of operation, clock source, clock divide, and configure for low power or long sample time.

Addresses: ADC0_CFG1 is 4003_B000h base + 8h offset = 4003_B008h

ADC1_CFG1 is 400B_B000h base + 8h offset = 400B_B008h

Bit	31	30	29	28	27	26	25	24	23	22	21	20	19	18	17	16
R	0															
W	[Shaded]															
Reset	0	0	0	0	0	0	0	0	0	0	0	0	0	0	0	0
Bit	15	14	13	12	11	10	9	8	7	6	5	4	3	2	1	0
R	0								ADLPC	ADIV		ADLSMP	MODE		ADICLK	
W	[Shaded]								ADLPC	ADIV		ADLSMP	MODE		ADICLK	
Reset	0	0	0	0	0	0	0	0	0	0	0	0	0	0	0	0

ADCx_CFG1 field descriptions

Field	Description
31–8 Reserved	This read-only field is reserved and always has the value zero.
7 ADLPC	Low-power configuration ADLPC controls the power configuration of the successive approximation converter. This optimizes power consumption when higher sample rates are not required.

Table continues on the next page...

ADCx_CFG1 field descriptions (continued)

Field	Description
	<p>0 Normal power configuration.</p> <p>1 Low power configuration. The power is reduced at the expense of maximum clock speed.</p>
6–5 ADIV	<p>Clock divide select</p> <p>ADIV selects the divide ratio used by the ADC to generate the internal clock ADCK.</p> <p>00 The divide ratio is 1 and the clock rate is input clock.</p> <p>01 The divide ratio is 2 and the clock rate is (input clock)/2.</p> <p>10 The divide ratio is 4 and the clock rate is (input clock)/4.</p> <p>11 The divide ratio is 8 and the clock rate is (input clock)/8.</p>
4 ADLSMP	<p>Sample time configuration</p> <p>ADLSMP selects between different sample times based on the conversion mode selected. This bit adjusts the sample period to allow higher impedance inputs to be accurately sampled or to maximize conversion speed for lower impedance inputs. Longer sample times can also be used to lower overall power consumption if continuous conversions are enabled and high conversion rates are not required. When ADLSMP=1, the long sample time select bits, (ADLSTS[1:0]), can select the extent of the long sample time.</p> <p>0 Short sample time.</p> <p>1 Long sample time.</p>
3–2 MODE	<p>Conversion mode selection</p> <p>MODE bits are used to select the ADC resolution mode.</p> <p>00 When DIFF=0: It is single-ended 8-bit conversion; when DIFF=1, it is differential 9-bit conversion with 2's complement output.</p> <p>01 When DIFF=0: It is single-ended 12-bit conversion; when DIFF=1, it is differential 13-bit conversion with 2's complement output.</p> <p>10 When DIFF=0: It is single-ended 10-bit conversion; when DIFF=1, it is differential 11-bit conversion with 2's complement output.</p> <p>11 When DIFF=0: It is single-ended 16-bit conversion; when DIFF=1, it is differential 16-bit conversion with 2's complement output.</p>
1–0 ADICLK	<p>Input clock select</p> <p>ADICLK bits select the input clock source to generate the internal clock, ADCK. Note that when the ADACK clock source is selected, it is not required to be active prior to conversion start. When it is selected and it is not active prior to a conversion start (ADACKEN=0), the asynchronous clock is activated at the start of a conversion and shuts off when conversions are terminated. In this case, there is an associated clock startup delay each time the clock source is re-activated.</p> <p>00 Bus clock.</p> <p>01 Bus clock divided by 2.</p> <p>10 Alternate clock (ALTCLK).</p> <p>11 Asynchronous clock (ADACK).</p>

31.3.3 Configuration register 2 (ADCx_CFG2)

CFG2 register selects the special high speed configuration for very high speed conversions and selects the long sample time duration during long sample mode.

Addresses: ADC0_CFG2 is 4003_B000h base + Ch offset = 4003_B00Ch

ADC1_CFG2 is 400B_B000h base + Ch offset = 400B_B00Ch

Bit	31	30	29	28	27	26	25	24	23	22	21	20	19	18	17	16
R	0															
W	[Shaded]															
Reset	0	0	0	0	0	0	0	0	0	0	0	0	0	0	0	0
Bit	15	14	13	12	11	10	9	8	7	6	5	4	3	2	1	0
R	0								0			MUXSEL	ADACKEN	ADHSC	ADLSTS	
W	[Shaded]								[Shaded]			MUXSEL	ADACKEN	ADHSC	ADLSTS	
Reset	0	0	0	0	0	0	0	0	0	0	0	0	0	0	0	0

ADCx_CFG2 field descriptions

Field	Description
31–8 Reserved	This read-only field is reserved and always has the value zero.
7–5 Reserved	This read-only field is reserved and always has the value zero.
4 MUXSEL	<p>ADC Mux select</p> <p>ADC Mux select bit is used to change the ADC mux setting to select between alternate sets of ADC channels.</p> <p>0 ADxxa channels are selected. 1 ADxxb channels are selected.</p>
3 ADACKEN	<p>Asynchronous clock output enable</p> <p>ADACKEN enables the ADC's asynchronous clock source and the clock source output regardless of the conversion and input clock select (ADICLK bits) status of the ADC. Based on MCU configuration, the asynchronous clock may be used by other modules (see Chip Configuration information). Setting this bit allows the clock to be used even while the ADC is idle or operating from a different clock source. Also, latency of initiating a single or first-continuous conversion with the asynchronous clock selected is reduced since the ADACK clock is already operational.</p> <p>0 Asynchronous clock output disabled; Asynchronous clock only enabled if selected by ADICLK and a conversion is active. 1 Asynchronous clock and clock output enabled regardless of the state of the ADC.</p>
2 ADHSC	High speed configuration

Table continues on the next page...

ADCx_CFG2 field descriptions (continued)

Field	Description
	<p>ADHSC configures the ADC for very high speed operation. The conversion sequence is altered (2 ADCK cycles added to the conversion time) to allow higher speed conversion clocks.</p> <p>0 Normal conversion sequence selected. 1 High speed conversion sequence selected (2 additional ADCK cycles to total conversion time).</p>
1-0 ADLSTS	<p>Long sample time select</p> <p>ADLSTS selects between the extended sample times when long sample time is selected (ADLSMP=1). This allows higher impedance inputs to be accurately sampled or to maximize conversion speed for lower impedance inputs. Longer sample times can also be used to lower overall power consumption when continuous conversions are enabled if high conversion rates are not required.</p> <p>00 Default longest sample time (20 extra ADCK cycles; 24 ADCK cycles total). 01 12 extra ADCK cycles; 16 ADCK cycles total sample time. 10 6 extra ADCK cycles; 10 ADCK cycles total sample time. 11 2 extra ADCK cycles; 6 ADCK cycles total sample time.</p>

31.3.4 ADC data result register (ADCx_Rn)

The data result registers (Rn) contain the result of an ADC conversion of the channel selected by the corresponding status and channel control register (SC1A:SC1n). For every status and channel control register, there is a corresponding data result register.

Unused bits in the Rn register are cleared in unsigned right justified modes and carry the sign bit (MSB) in sign extended 2's complement modes. For example, when configured for 10-bit single-ended mode, D[15:10] are cleared. When configured for 11-bit differential mode, D[15:10] carry the sign bit (bit 10 extended through bit 15).

The following table describes the behavior of the data result registers in the different modes of operation.

Table 31-44. Data result register description

Conversion mode	D15	D14	D13	D12	D11	D10	D9	D8	D7	D6	D5	D4	D3	D2	D1	D0	Format
16-bit differential	S	D	D	D	D	D	D	D	D	D	D	D	D	D	D	D	Signed 2's complement
16-bit single-ended	D	D	D	D	D	D	D	D	D	D	D	D	D	D	D	D	Unsigned right justified
13-bit differential	S	S	S	S	D	D	D	D	D	D	D	D	D	D	D	D	Sign extended 2's complement
12-bit single-ended	0	0	0	0	D	D	D	D	D	D	D	D	D	D	D	D	Unsigned right justified

Table continues on the next page...

Table 31-44. Data result register description (continued)

Conversion mode	D15	D14	D13	D12	D11	D10	D9	D8	D7	D6	D5	D4	D3	D2	D1	D0	Format
11-bit differential	S	S	S	S	S	S	D	D	D	D	D	D	D	D	D	D	Sign extended 2's complement
10-bit single-ended	0	0	0	0	0	0	D	D	D	D	D	D	D	D	D	D	Unsigned right justified
9-bit differential	S	S	S	S	S	S	S	S	D	D	D	D	D	D	D	D	Sign extended 2's complement
8-bit single-ended	0	0	0	0	0	0	0	0	D	D	D	D	D	D	D	D	Unsigned right justified

NOTE

S: Sign bit or sign bit extension;

D: Data (2's complement data if indicated)

Addresses: ADC0_RA is 4003_B000h base + 10h offset = 4003_B010h

ADC0_RB is 4003_B000h base + 14h offset = 4003_B014h

ADC1_RA is 400B_B000h base + 10h offset = 400B_B010h

ADC1_RB is 400B_B000h base + 14h offset = 400B_B014h

Bit	31	30	29	28	27	26	25	24	23	22	21	20	19	18	17	16	15	14	13	12	11	10	9	8	7	6	5	4	3	2	1	0		
R	0																D																	
W	[Shaded]																																	
Reset	0	0	0	0	0	0	0	0	0	0	0	0	0	0	0	0	0	0	0	0	0	0	0	0	0	0	0	0	0	0	0	0		

ADCx_Rn field descriptions

Field	Description
31–16 Reserved	This read-only field is reserved and always has the value zero.
15–0 D	Data result

31.3.5 Compare value registers (ADCx_CVn)

The compare value registers (CV1 and CV2) contain a compare value used to compare with the conversion result when the compare function is enabled (ACFE=1). This register is formatted the same for both bit position definition and value format (unsigned or sign-extended 2's complement) as the data result registers (Rn) in the different modes of operation. Therefore, the compare function only uses the compare value register bits that are related to the ADC mode of operation.

register Definition

The compare value 2 register (CV2) is utilized only when the compare range function is enabled (ACREN=1).

Addresses: ADC0_CV1 is 4003_B000h base + 18h offset = 4003_B018h
 ADC0_CV2 is 4003_B000h base + 1Ch offset = 4003_B01Ch
 ADC1_CV1 is 400B_B000h base + 18h offset = 400B_B018h
 ADC1_CV2 is 400B_B000h base + 1Ch offset = 400B_B01Ch

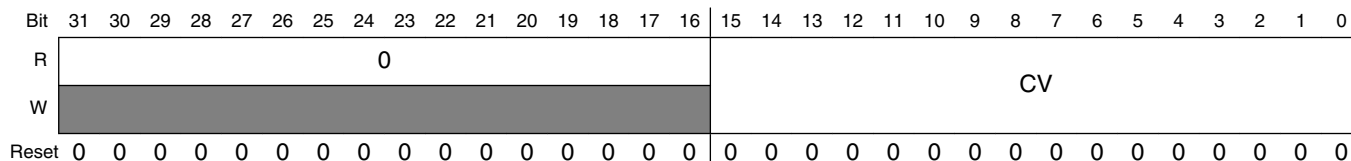

ADCx_CVn field descriptions

Field	Description
31–16 Reserved	This read-only field is reserved and always has the value zero.
15–0 CV	Compare value

31.3.6 Status and control register 2 (ADCx_SC2)

The SC2 register contains the conversion active, hardware/software trigger select, compare function and voltage reference select of the ADC module.

Addresses: ADC0_SC2 is 4003_B000h base + 20h offset = 4003_B020h
 ADC1_SC2 is 400B_B000h base + 20h offset = 400B_B020h

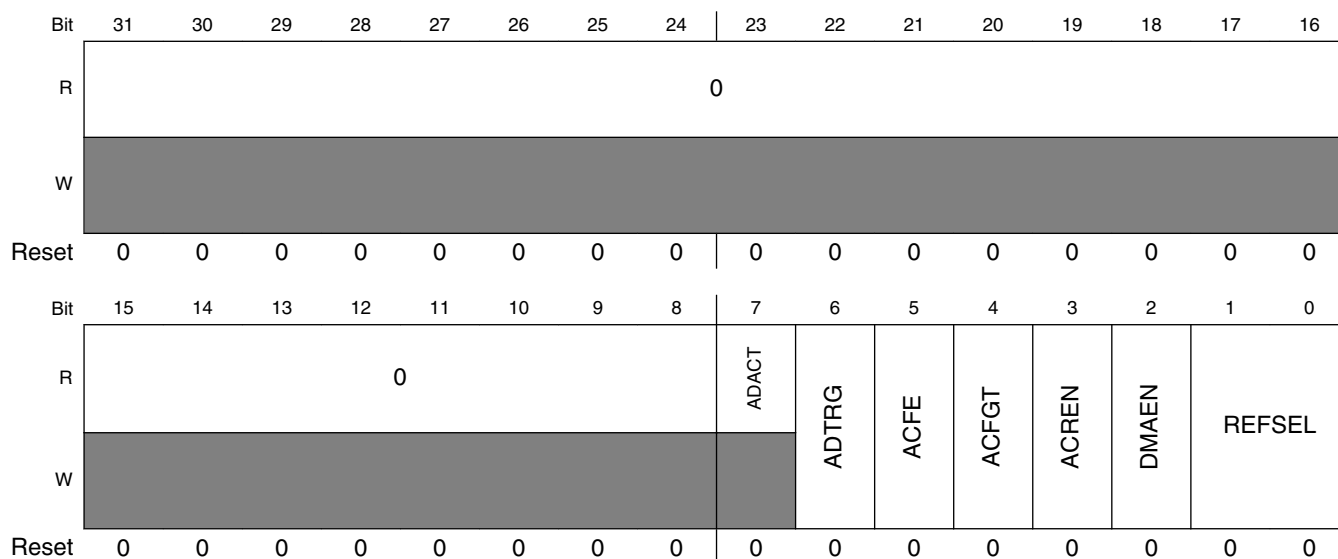

ADCx_SC2 field descriptions

Field	Description
31–8 Reserved	This read-only field is reserved and always has the value zero.
7 ADACT	<p>Conversion active</p> <p>ADACT indicates that a conversion or hardware averaging is in progress. ADACT is set when a conversion is initiated and cleared when a conversion is completed or aborted.</p> <p>0 Conversion not in progress. 1 Conversion in progress.</p>
6 ADTRG	<p>Conversion trigger select</p> <p>ADTRG selects the type of trigger used for initiating a conversion. Two types of trigger are selectable: software trigger and hardware trigger. When software trigger is selected, a conversion is initiated following a write to SC1A. When hardware trigger is selected, a conversion is initiated following the assertion of the ADHWT input after a pulse of the ADHWTSn input.</p> <p>0 Software trigger selected. 1 Hardware trigger selected.</p>
5 ACFE	<p>Compare function enable</p> <p>ACFE enables the compare function.</p> <p>0 Compare function disabled. 1 Compare function enabled.</p>
4 ACFGT	<p>Compare function greater than enable</p> <p>ACFGT configures the compare function to check the conversion result relative to the compare value register(s) (CV1 and CV2) based upon the value of ACREN. The ACFE bit must be set for ACFGT to have any effect.</p> <p>0 Configures less than threshold, outside range not inclusive and inside range not inclusive functionality based on the values placed in the CV1 and CV2 registers. 1 Configures greater than or equal to threshold, outside range inclusive and inside range inclusive functionality based on the values placed in the CV1 and CV2 registers.</p>
3 ACREN	<p>Compare function range enable</p> <p>ACREN configures the compare function to check if the conversion result of the input being monitored is either between or outside the range formed by the compare value registers (CV1 and CV2) determined by the value of ACFGT. The ACFE bit must be set for ACFGT to have any effect.</p> <p>0 Range function disabled. Only the compare value 1 register (CV1) is compared. 1 Range function enabled. Both compare value registers (CV1 and CV2) are compared.</p>
2 DMAEN	<p>DMA enable</p> <p>0 DMA is disabled. 1 DMA is enabled and will assert the ADC DMA request during a ADC conversion complete event noted by the assertion of any of the ADC COCO flags.</p>
1–0 REFSEL	<p>Voltage reference selection</p> <p>REFSEL bits select the voltage reference source used for conversions.</p>

Table continues on the next page...

ADCx_SC2 field descriptions (continued)

Field	Description
00	Default voltage reference pin pair (external pins V_{REFH} and V_{REFL})
01	Alternate reference pair (V_{ALTH} and V_{ALT_L}). This pair may be additional external pins or internal sources depending on MCU configuration. Consult the Chip Configuration information for details specific to this MCU.
10	Reserved
11	Reserved

31.3.7 Status and control register 3 (ADCx_SC3)

The SC3 register controls the calibration, continuous convert, and hardware averaging functions of the ADC module.

Addresses: ADC0_SC3 is 4003_B000h base + 24h offset = 4003_B024h

ADC1_SC3 is 400B_B000h base + 24h offset = 400B_B024h

Bit	31	30	29	28	27	26	25	24	23	22	21	20	19	18	17	16
R	0															
W	[Reserved]															
Reset	0	0	0	0	0	0	0	0	0	0	0	0	0	0	0	0
Bit	15	14	13	12	11	10	9	8	7	6	5	4	3	2	1	0
R	0								CAL	CALF	0		ADCO	AVGE	AVGS	
W	[Reserved]								CAL	[Reserved]	[Reserved]	[Reserved]	ADCO	AVGE	AVGS	
Reset	0	0	0	0	0	0	0	0	0	0	0	0	0	0	0	0

ADCx_SC3 field descriptions

Field	Description
31–8 Reserved	This read-only field is reserved and always has the value zero.
7 CAL	Calibration CAL begins the calibration sequence when set. This bit stays set while the calibration is in progress and is cleared when the calibration sequence is completed. The CALF bit must be checked to determine the result of the calibration sequence. Once started, the calibration routine cannot be interrupted by writes to the ADC registers or the results will be invalid and the CALF bit will set. Setting the CAL bit will abort any current conversion.
6 CALF	Calibration failed flag CALF displays the result of the calibration sequence. The calibration sequence will fail if ADTRG = 1, any ADC register is written, or any stop mode is entered before the calibration sequence completes. The CALF bit is cleared by writing a 1 to this bit.

Table continues on the next page...

ADCx_SC3 field descriptions (continued)

Field	Description
	0 Calibration completed normally. 1 Calibration failed. ADC accuracy specifications are not guaranteed.
5–4 Reserved	This read-only field is reserved and always has the value zero.
3 ADCO	Continuous conversion enable ADCO enables continuous conversions. 0 One conversion or one set of conversions if the hardware average function is enabled (AVGE=1) after initiating a conversion. 1 Continuous conversions or sets of conversions if the hardware average function is enabled (AVGE=1) after initiating a conversion.
2 AVGE	Hardware average enable AVGE enables the hardware average function of the ADC. 0 Hardware average function disabled. 1 Hardware average function enabled.
1–0 AVGS	Hardware average select AVGS determines how many ADC conversions will be averaged to create the ADC average result. 00 4 samples averaged. 01 8 samples averaged. 10 16 samples averaged. 11 32 samples averaged.

31.3.8 ADC offset correction register (ADCx_OFS)

The ADC offset correction register (OFS) contains the user selected or calibration generated offset error correction value. This register is a 2’s complement, left justified, 16-bit value. The value in the offset correction registers (OFS) is subtracted from the conversion and the result is transferred into the result registers (Rn). If the result is above the maximum or below the minimum result value, it is forced to the appropriate limit for the current mode of operation.

Addresses: ADC0_OFS is 4003_B000h base + 28h offset = 4003_B028h

ADC1_OFS is 400B_B000h base + 28h offset = 400B_B028h

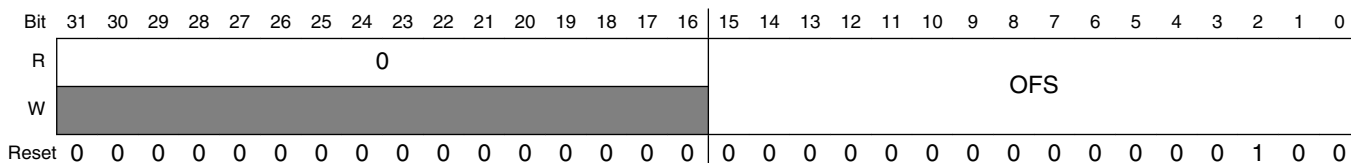

ADCx_OFS field descriptions

Field	Description
31–16 Reserved	This read-only field is reserved and always has the value zero.
15–0 OFS	Offset error correction value

31.3.9 ADC plus-side gain register (ADCx_PG)

The plus-side gain register (PG) contains the gain error correction for the plus-side input in differential mode or the overall conversion in single-ended mode. PG, a 16-bit real number in binary format, is the gain adjustment factor, with the radix point fixed between ADPG15 and ADPG14. This register must be written by the user with the value described in the calibration procedure or the gain error specifications may not be met.

Addresses: ADC0_PG is 4003_B000h base + 2Ch offset = 4003_B02Ch

ADC1_PG is 400B_B000h base + 2Ch offset = 400B_B02Ch

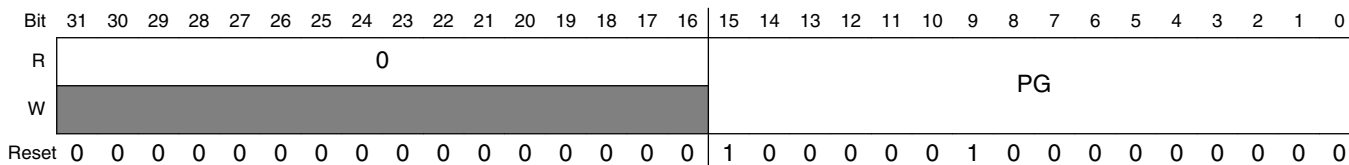

ADCx_PG field descriptions

Field	Description
31–16 Reserved	This read-only field is reserved and always has the value zero.
15–0 PG	Plus-side gain

31.3.10 ADC minus-side gain register (ADCx_MG)

The minus-side gain register (MG) contains the gain error correction for the minus-side input in differential mode. This register is ignored in single-ended mode. MG, a 16-bit real number in binary format, is the gain adjustment factor, with the radix point fixed between ADMG15 and ADMG14. This register must be written by the user with the value described in the calibration procedure or the gain error specifications may not be met.

Addresses: ADC0_MG is 4003_B000h base + 30h offset = 4003_B030h

ADC1_MG is 400B_B000h base + 30h offset = 400B_B030h

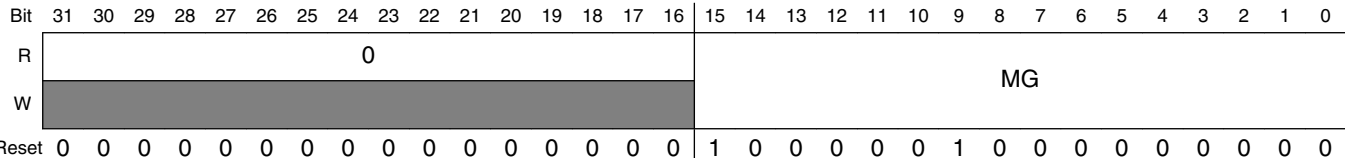

ADCx_MG field descriptions

Field	Description
31–16 Reserved	This read-only field is reserved and always has the value zero.
15–0 MG	Minus-side gain

31.3.11 ADC plus-side general calibration value register (ADCx_CLPD)

The plus-side general calibration value registers (CLPx) contain calibration information that is generated by the calibration function. These registers contain seven calibration values of varying widths: CLP0[5:0], CLP1[6:0], CLP2[7:0], CLP3[8:0], CLP4[9:0], CLPS[5:0], and CLPD[5:0]. CLPx are automatically set once the self calibration sequence is done (CAL is cleared). If these registers are written by the user after calibration, the linearity error specifications may not be met.

Addresses: ADC0_CLPD is 4003_B000h base + 34h offset = 4003_B034h

ADC1_CLPD is 400B_B000h base + 34h offset = 400B_B034h

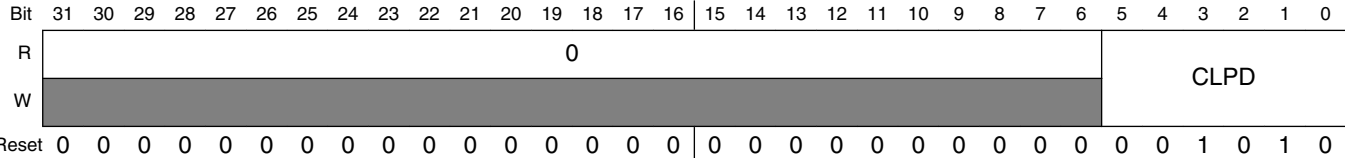

ADCx_CLPD field descriptions

Field	Description
31–6 Reserved	This read-only field is reserved and always has the value zero.
5–0 CLPD	Calibration value

31.3.12 ADC plus-side general calibration value register (ADCx_CLPS)

For more information, refer to CLPD register description.

Addresses: ADC0_CLPS is 4003_B000h base + 38h offset = 4003_B038h

ADC1_CLPS is 400B_B000h base + 38h offset = 400B_B038h

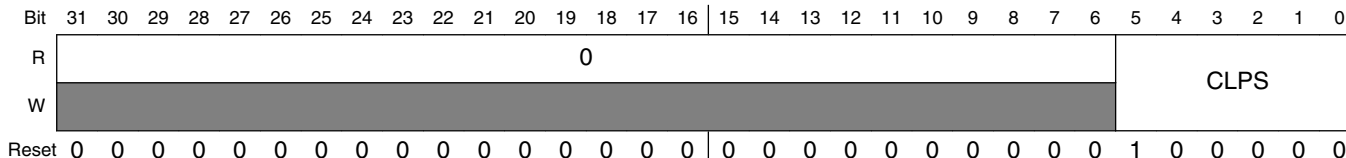

ADCx_CLPS field descriptions

Field	Description
31–6 Reserved	This read-only field is reserved and always has the value zero.
5–0 CLPS	Calibration value

31.3.13 ADC plus-side general calibration value register (ADCx_CLP4)

For more information, refer to CLPD register description.

Addresses: ADC0_CLP4 is 4003_B000h base + 3Ch offset = 4003_B03Ch

ADC1_CLP4 is 400B_B000h base + 3Ch offset = 400B_B03Ch

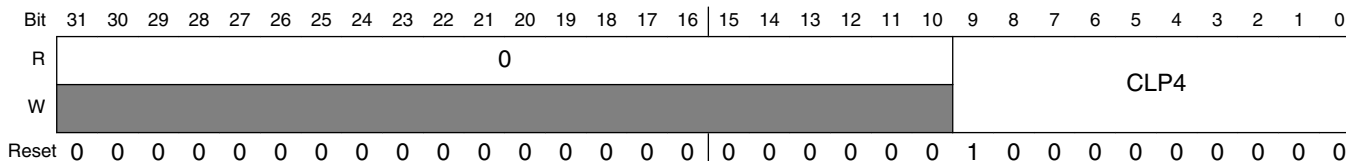

ADCx_CLP4 field descriptions

Field	Description
31–10 Reserved	This read-only field is reserved and always has the value zero.
9–0 CLP4	Calibration value

31.3.14 ADC plus-side general calibration value register (ADCx_CLP3)

For more information, refer to CLPD register description.

Addresses: ADC0_CLP3 is 4003_B000h base + 40h offset = 4003_B040h

ADC1_CLP3 is 400B_B000h base + 40h offset = 400B_B040h

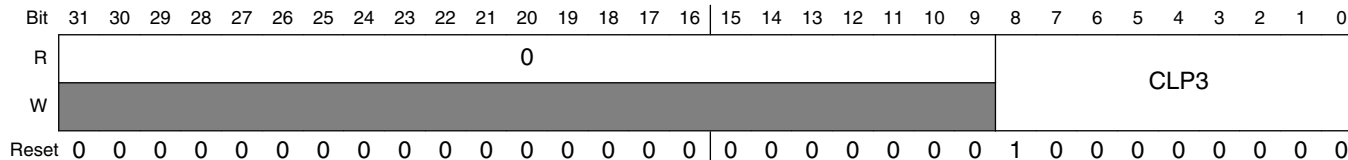

ADCx_CLP3 field descriptions

Field	Description
31–9 Reserved	This read-only field is reserved and always has the value zero.
8–0 CLP3	Calibration value

31.3.15 ADC plus-side general calibration value register (ADCx_CLP2)

For more information, refer to CLPD register description.

Addresses: ADC0_CLP2 is 4003_B000h base + 44h offset = 4003_B044h

ADC1_CLP2 is 400B_B000h base + 44h offset = 400B_B044h

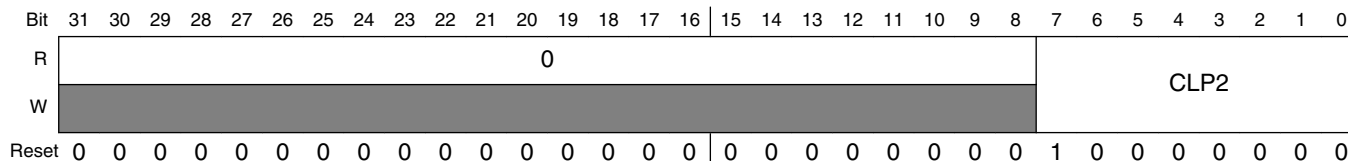

ADCx_CLP2 field descriptions

Field	Description
31–8 Reserved	This read-only field is reserved and always has the value zero.
7–0 CLP2	Calibration value

31.3.16 ADC plus-side general calibration value register (ADCx_CLP1)

For more information, refer to CLPD register description.

Addresses: ADC0_CLP1 is 4003_B000h base + 48h offset = 4003_B048h

ADC1_CLP1 is 400B_B000h base + 48h offset = 400B_B048h

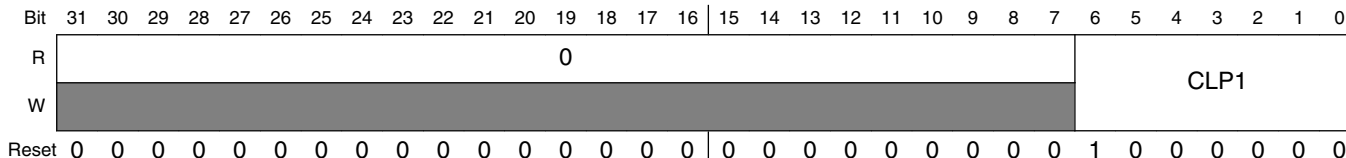

ADCx_CLP1 field descriptions

Field	Description
31–7 Reserved	This read-only field is reserved and always has the value zero.
6–0 CLP1	Calibration value

31.3.17 ADC plus-side general calibration value register (ADCx_CLP0)

For more information, refer to CLPD register description.

Addresses: ADC0_CLP0 is 4003_B000h base + 4Ch offset = 4003_B04Ch

ADC1_CLP0 is 400B_B000h base + 4Ch offset = 400B_B04Ch

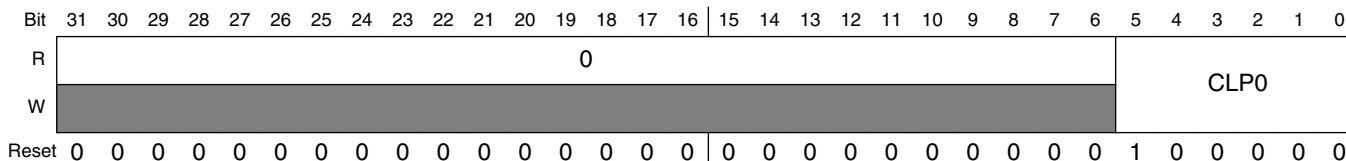

ADCx_CLP0 field descriptions

Field	Description
31–6 Reserved	This read-only field is reserved and always has the value zero.
5–0 CLP0	Calibration value

31.3.18 ADC PGA register (ADCx_PGA)

Addresses: ADC0_PGA is 4003_B000h base + 50h offset = 4003_B050h

ADC1_PGA is 400B_B000h base + 50h offset = 400B_B050h

Bit	31	30	29	28	27	26	25	24	23	22	21	20	19	18	17	16
R	0								PGAEN	0		PGALPb	PGAG			
W											0					
Reset	0	0	0	0	0	0	0	0	0	0	0	0	0	0	0	0
Bit	15	14	13	12	11	10	9	8	7	6	5	4	3	2	1	0
R	0															
W																
Reset	0	0	0	0	0	0	0	0	0	0	0	0	0	0	0	0

ADCx_PGA field descriptions

Field	Description
31–24 Reserved	This read-only field is reserved and always has the value zero.
23 PGAEN	PGA enable 0 PGA disabled. 1 PGA enabled.
22 Reserved	This read-only field is reserved and always has the value zero.
21 Reserved	This field is reserved.
20 PGALPb	PGA low-power mode control 0 PGA runs in low power mode. 1 PGA runs in normal power mode.
19–16 PGAG	PGA gain setting $PGA\ gain = 2^{(PGAG)}$ 0000 1 0001 2 0010 4 0011 8 0100 16 0101 32 0110 64 0111 Reserved

Table continues on the next page...

ADCx_PGA field descriptions (continued)

Field	Description
1000	Reserved
1001	Reserved
1010	Reserved
1011	Reserved
1100	Reserved
1101	Reserved
1110	Reserved
1111	Reserved
15–0 Reserved	This read-only field is reserved and always has the value zero.

31.3.19 ADC minus-side general calibration value register (ADCx_CLMD)

CLMx contain calibration information that is generated by the calibration function. These registers contain seven calibration values of varying widths: CLM0[5:0], CLM1[6:0], CLM2[7:0], CLM3[8:0], CLM4[9:0], CLM5[5:0], and CLMD[5:0]. CLMx are automatically set once the self calibration sequence is done (CAL is cleared). If these registers are written by the user after calibration, the linearity error specifications may not be met.

Addresses: ADC0_CLMD is 4003_B000h base + 54h offset = 4003_B054h

ADC1_CLMD is 400B_B000h base + 54h offset = 400B_B054h

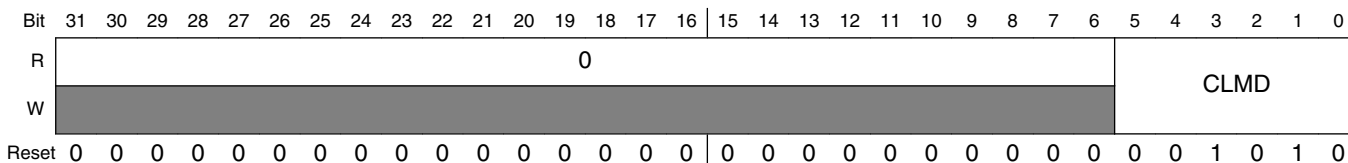

ADCx_CLMD field descriptions

Field	Description
31–6 Reserved	This read-only field is reserved and always has the value zero.
5–0 CLMD	Calibration value

31.3.20 ADC minus-side general calibration value register (ADCx_CLMS)

For more information, refer to CLMD register description.

Addresses: ADC0_CLMS is 4003_B000h base + 58h offset = 4003_B058h

ADC1_CLMS is 400B_B000h base + 58h offset = 400B_B058h

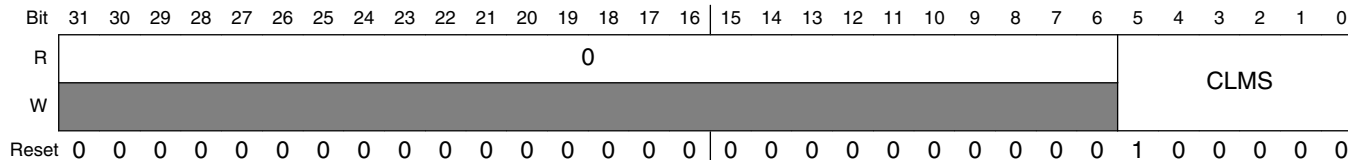

ADCx_CLMS field descriptions

Field	Description
31–6 Reserved	This read-only field is reserved and always has the value zero.
5–0 CLMS	Calibration value

31.3.21 ADC minus-side general calibration value register (ADCx_CLM4)

For more information, refer to CLMD register description.

Addresses: ADC0_CLM4 is 4003_B000h base + 5Ch offset = 4003_B05Ch

ADC1_CLM4 is 400B_B000h base + 5Ch offset = 400B_B05Ch

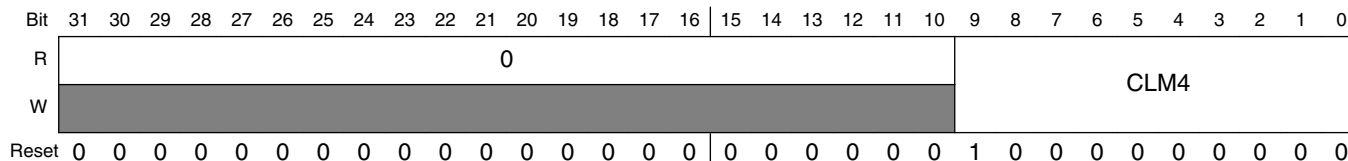

ADCx_CLM4 field descriptions

Field	Description
31–10 Reserved	This read-only field is reserved and always has the value zero.
9–0 CLM4	Calibration value

31.3.22 ADC minus-side general calibration value register (ADCx_CLM3)

For more information, refer to CLMD register description.

Addresses: ADC0_CLM3 is 4003_B000h base + 60h offset = 4003_B060h

ADC1_CLM3 is 400B_B000h base + 60h offset = 400B_B060h

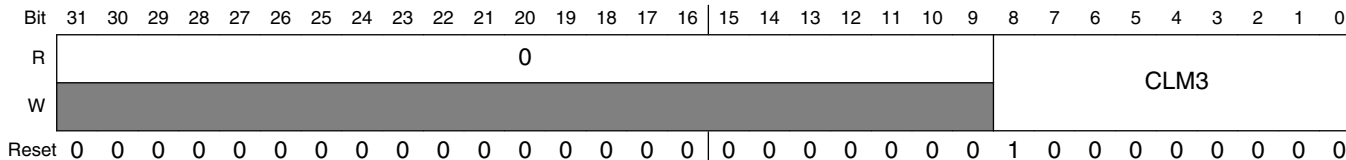

ADCx_CLM3 field descriptions

Field	Description
31–9 Reserved	This read-only field is reserved and always has the value zero.
8–0 CLM3	Calibration value

31.3.23 ADC minus-side general calibration value register (ADCx_CLM2)

For more information, refer to CLMD register description.

Addresses: ADC0_CLM2 is 4003_B000h base + 64h offset = 4003_B064h

ADC1_CLM2 is 400B_B000h base + 64h offset = 400B_B064h

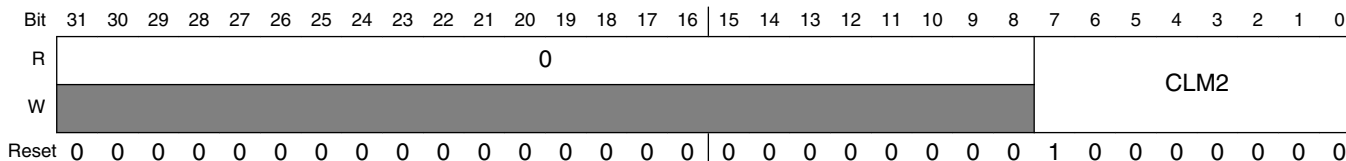

ADCx_CLM2 field descriptions

Field	Description
31–8 Reserved	This read-only field is reserved and always has the value zero.
7–0 CLM2	Calibration value

31.3.24 ADC minus-side general calibration value register (ADCx_CLM1)

For more information, refer to CLMD register description.

Addresses: ADC0_CLM1 is 4003_B000h base + 68h offset = 4003_B068h

ADC1_CLM1 is 400B_B000h base + 68h offset = 400B_B068h

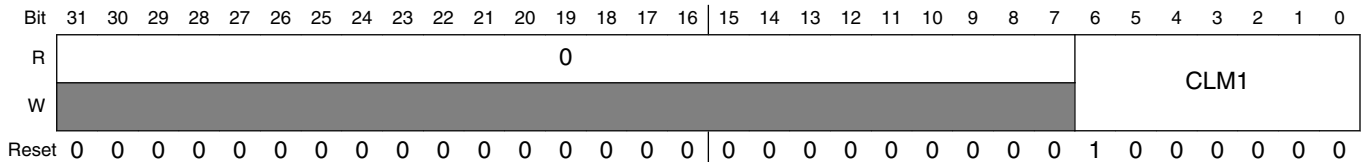

ADCx_CLM1 field descriptions

Field	Description
31–7 Reserved	This read-only field is reserved and always has the value zero.
6–0 CLM1	Calibration value

31.3.25 ADC minus-side general calibration value register (ADCx_CLM0)

For more information, refer to CLMD register description.

Addresses: ADC0_CLM0 is 4003_B000h base + 6Ch offset = 4003_B06Ch

ADC1_CLM0 is 400B_B000h base + 6Ch offset = 400B_B06Ch

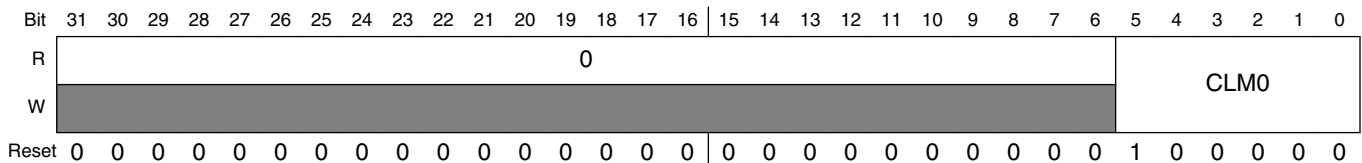

ADCx_CLM0 field descriptions

Field	Description
31–6 Reserved	This read-only field is reserved and always has the value zero.
5–0 CLM0	Calibration value

31.4 Functional description

The ADC module is disabled during reset, in low power stop mode (refer to the Power Management information for details), or when the ADCH bits in SC1n are all high. The module is idle when a conversion has completed and another conversion has not been initiated. When it is idle and the asynchronous clock output enable is disabled (ADACKEN is 0), the module is in its lowest power state. The ADC can perform an analog-to-digital conversion on any of the software selectable channels. All modes perform conversion by a successive approximation algorithm.

To meet accuracy specifications, the ADC module must be calibrated using the on chip calibration function. See [Calibration function](#) for details on how to perform calibration.

When the conversion is completed, the result is placed in the data registers (Rn). The respective conversion complete flag (COCO) is then set and an interrupt is generated if the respective conversion complete interrupt has been enabled (AIEN=1).

The ADC module has the capability of automatically comparing the result of a conversion with the contents of the compare value registers. The compare function is enabled by setting the ACFE bit and operates with any of the conversion modes and configurations.

The ADC module has the capability of automatically averaging the result of multiple conversions. The hardware average function is enabled by setting the AVGE bit and operates with any of the conversion modes and configurations.

NOTE

For the chip specific modes of operation, refer to the Power Management information of this MCU.

31.4.1 PGA functional description

The Programmable Gain Amplifier (PGA) is designed to increase the dynamic range by amplifying low-amplitude signals before they are fed to the 16-bit SAR ADC. The gain of this amplifier is ranged between 1 to 64 in (2^N) steps (1,2,4,8,16,32,64).

This block is designed to work with differential input and output with input signals that range from 0 -1.2 V \pm 10 mV. The output common mode of the PGA is determined based on the SAR ADC requirement.

The PGA has only one voltage reference pair. The positive reference used is chip specific and depends on the MCU configuration. Refer to the Chip Configuration chapter on the PGA Voltage Reference specific to this MCU. The ground reference is the analog ground for the PGA.

The ADC PGA register allows to control the PGA gain and modes of operation.

31.4.2 Clock select and divide control

One of four clock sources can be selected as the clock source for the ADC module. This clock source is then divided by a configurable value to generate the input clock to the converter (ADCK). The clock is selected from one of the following sources by means of the ADICLK bits.

- The bus clock. This is the default selection following reset.
- The bus clock divided by two. For higher bus clock rates, this allows a maximum divide by 16 of the bus clock with using the ADIV bits.
- ALTCLK, as defined for this MCU. Refer to the Chip Configuration information.
- The asynchronous clock (ADACK). This clock is generated from a clock source within the ADC module. Note that when the ADACK clock source is selected, it is not required to be active prior to conversion start. When it is selected and it is not active prior to a conversion start (ADACKEN=0), the asynchronous clock is activated at the start of a conversion and shuts off when conversions are terminated. In this case, there is an associated clock startup delay each time the clock source is re-activated. To avoid the conversion time variability and latency associated with the ADACK clock startup, set ADACKEN=1 and wait the worst case startup time of 5 μ s prior to initiating any conversions using the ADACK clock source. Conversions are possible using ADACK as the input clock source while the MCU is in Normal Stop mode. Refer to [Power Control](#) for more information.

Whichever clock is selected, its frequency must fall within the specified frequency range for ADCK. If the available clocks are too slow, the ADC may not perform according to specifications. If the available clocks are too fast, the clock must be divided to the appropriate frequency. This divider is specified by the ADIV bits and can be divide-by 1, 2, 4, or 8.

31.4.3 Voltage reference selection

The ADC can be configured to accept one of the two voltage reference pairs as the reference voltage (V_{REFSH} and V_{REFSL}) used for conversions. Each pair contains a positive reference that must be between the minimum Ref Voltage High and V_{DDA} , and a ground reference that must be at the same potential as V_{SSA} . The two pairs are external (V_{REFH} and V_{REFL}) and alternate (V_{ALTH} and V_{ALTL}). These voltage references are selected using the REFSEL bits in the SC2 register. The alternate (V_{ALTH} and V_{ALTL}) voltage reference pair may select additional external pins or internal sources depending on MCU configuration. Refer to the Chip Configuration information on the Voltage References specific to this MCU.

31.4.4 Hardware trigger and channel selects

The ADC module has a selectable asynchronous hardware conversion trigger, ADHWT, that is enabled when the ADTRG bit is set and a hardware trigger select event (ADHWTSn) has occurred. This source is not available on all MCUs. Refer to the Chip Configuration chapter for information on the ADHWT source and the ADHWTSn configurations specific to this MCU.

When a ADHWT source is available and hardware trigger is enabled (ADTRG=1), a conversion is initiated on the rising edge of ADHWT after a hardware trigger select event (ADHWTSn) has occurred. If a conversion is in progress when a rising edge of a trigger occurs, the rising edge is ignored. In continuous convert configuration, only the initial rising edge to launch continuous conversions is observed, and until conversion gets aborted the ADC continues to do conversions on the same ADC status and control register that initiated the conversion. The hardware trigger function operates in conjunction with any of the conversion modes and configurations.

The hardware trigger select event (ADHWTSn) must be set prior to the receipt of the ADHWT signal. If these conditions are not met, the converter may ignore the trigger or use the incorrect configuration. If a hardware trigger select event gets asserted during a conversion, it must stay asserted until the end of current conversion and remain set until the receipt of the ADHWT signal to trigger a new conversion. The channel and status fields selected for the conversion depend on the active trigger select signal (ADHWTSn active selects SC1A; ADHWTSn active selects SC1n).

Note

Asserting more than one hardware trigger select signal (ADHWTSn) at the same time results in unknown results. To avoid this, select only one hardware trigger select signal (ADHWTSn) prior to the next intended conversion.

When the conversion is completed, the result is placed in the data registers associated with the ADHWTSn received (ADHWTSa active selects RA register; ADHWTSn active selects Rn register). The conversion complete flag associated with the ADHWTSn received (the COCO bit in SC1n register) is then set and an interrupt is generated if the respective conversion complete interrupt has been enabled (AIEN=1).

31.4.5 Conversion control

Conversions can be performed as determined by the CFG1[MODE] bits and the SC1n[DIFF] bit as shown in the description of CFG1[MODE].

Conversions can be initiated by a software or hardware trigger. In addition, the ADC module can be configured for low power operation, long sample time, continuous conversion, hardware average, and automatic compare of the conversion result to a software determined compare value.

31.4.5.1 Initiating conversions

A conversion is initiated:

- Following a write to SC1A register (with ADCH bits not all 1's) if software triggered operation is selected (ADTRG=0).
- Following a hardware trigger (ADHWT) event if hardware triggered operation is selected (ADTRG=1) and a hardware trigger select event (ADHWTSn) has occurred. The channel and status fields selected depend on the active trigger select signal (ADHWTSa active selects SC1A register; ADHWTSn active selects SC1n register; if neither is active, the off condition is selected).

Note

Selecting more than one hardware trigger select signal (ADHWTSn) prior to a conversion completion will result in unknown results. To avoid this, select only one hardware trigger select signal (ADHWTSn) prior to a conversion completion.

- Following the transfer of the result to the data registers when continuous conversion is enabled (ADCO=1).

If continuous conversions are enabled, a new conversion is automatically initiated after the completion of the current conversion. In software triggered operation ($ADTRG=0$), continuous conversions begin after SC1A register is written and continue until aborted. In hardware triggered operation ($ADTRG=1$ and one ADHWTSn event has occurred), continuous conversions begin after a hardware trigger event and continue until aborted.

If hardware averaging is enabled, a new conversion is automatically initiated after the completion of the current conversion until the correct number of conversions is completed. In software triggered operation, conversions begin after SC1A register is written. In hardware triggered operation, conversions begin after a hardware trigger. If continuous conversions are also enabled, a new set of conversions to be averaged are initiated following the last of the selected number of conversions.

31.4.5.2 Completing conversions

A conversion is completed when the result of the conversion is transferred into the data result registers, Rn. If the compare functions are disabled, this is indicated by the setting of the COCO bit in the respective SC1n register. If hardware averaging is enabled, the respective COCO bit sets only if the last of the selected number of conversions is completed. If the compare function is enabled, the respective COCO bit sets and conversion result data is transferred only if the compare condition is true. If both hardware averaging and compare functions are enabled then the respective COCO bit sets only if the last of the selected number of conversions is completed and the compare condition is true. An interrupt is generated if the respective AIEN bit is high at the time that the respective COCO bit is set.

31.4.5.3 Aborting conversions

Any conversion in progress is aborted when:

- Writing to SC1A register while it is actively controlling a conversion, aborts the current conversion. In software trigger mode ($ADTRG=0$), a write to SC1A register initiates a new conversion (if the ADCH field in SC1A is equal to a value other than all 1s). Writing to any of the SC1(B-n) registers while that specific SC1(B-n) register is actively controlling a conversion aborts the current conversion. The SC1(B-n) registers are not used for software trigger operation and therefore writes to the SC1(B-n) registers do not initiate a new conversion.
- A write to any ADC register besides the SC1A:SC1n registers occurs. This indicates a mode of operation change has occurred and the current conversion is therefore invalid.

- The MCU is reset or enters Low Power Stop modes.
- The MCU enters Normal Stop mode with ADACK not enabled.

When a conversion is aborted, the contents of the data registers, R_n , are not altered. The data registers continue to be the values transferred after the completion of the last successful conversion. If the conversion was aborted by a reset or Low Power Stop modes, R_A and R_n return to their reset states.

31.4.5.4 Power control

The ADC module remains in its idle state until a conversion is initiated. If ADACK is selected as the conversion clock source, but the asynchronous clock output is disabled ($ADACKEN=0$), the ADACK clock generator also remains in its idle state (disabled) until a conversion is initiated. If the asynchronous clock output is enabled ($ADACKEN=1$), it remains active regardless of the state of the ADC or the MCU power mode.

Power consumption when the ADC is active can be reduced by setting ADLPC. This results in a lower maximum value for f_{ADCK} .

31.4.5.5 Sample time and total conversion time

For short sample ($ADLSMP=0$), there is a 2-cycle adder for first conversion over the base sample time of 4 ADCK cycles. For high speed conversions ($ADHSC=1$), there is an additional 2-cycle adder on any conversion. The table below summarizes sample times for the possible ADC configurations.

ADC Configuration			Sample time (ADCK cycles)	
ADLSMP	ADLSTS	ADHSC	First or Single	Subsequent
0	X	0	6	4
1	00	0	24	
1	01	0	16	
1	10	0	10	
1	11	0	6	
0	X	1	8	6
1	00	1	26	
1	01	1	18	
1	10	1	12	

Table continues on the next page...

functional description

ADC Configuration			Sample time (ADCK cycles)
1	11	1	8

The total conversion time depends upon: the sample time (as determined by ADLSMP and ADLSTS bits), the MCU bus frequency, the conversion mode (as determined by MODE and SC1n[DIFF] bits), the high speed configuration (ADHSC bit), and the frequency of the conversion clock (f_{ADCK}).

The ADHSC bit is used to configure a higher clock input frequency. This will allow faster overall conversion times. To meet internal ADC timing requirements, the ADHSC bit adds additional ADCK cycles. Conversions with ADHSC = 1 take two more ADCK cycles. ADHSC should be used when the ADCLK exceeds the limit for ADHSC = 0.

After the module becomes active, sampling of the input begins. ADLSMP and ADLSTS select between sample times based on the conversion mode that is selected. When sampling is completed, the converter is isolated from the input channel and a successive approximation algorithm is performed to determine the digital value of the analog signal. The result of the conversion is transferred to Rn upon completion of the conversion algorithm.

If the bus frequency is less than the f_{ADCK} frequency, precise sample time for continuous conversions cannot be guaranteed when short sample is enabled (ADLSMP=0).

The maximum total conversion time is determined by the clock source chosen and the divide ratio selected. The clock source is selectable by the ADICLK bits, and the divide ratio is specified by the ADIV bits.

The maximum total conversion time for all configurations is summarized in the equation below. Refer to the following tables for the variables referenced in the equation.

$$\text{ConversionTime} = \text{SFCAdder} + \text{AverageNum} \times (\text{BCT} + \text{LSTAdder} + \text{HSCAdder})$$

Figure 31-95. Conversion time equation

Table 31-107. Single or first continuous time adder (SFCAdder)

ADLSMP	ADACKEN	ADICLK	Single or first continuous time adder (SFCAdder)
1	x	0x, 10	3 ADCK cycles + 5 bus clock cycles
1	1	11	3 ADCK cycles + 5 bus clock cycles ¹
1	0	11	5 μ s + 3 ADCK cycles + 5 bus clock cycles
0	x	0x, 10	5 ADCK cycles + 5 bus clock cycles
0	1	11	5 ADCK cycles + 5 bus clock cycles ¹
0	0	11	5 μ s + 5 ADCK cycles + 5 bus clock cycles

1. To achieve this time, ADACKEN must be 1 for at least 5 μ s prior to the conversion is initiated.

Table 31-108. Average number factor (AverageNum)

AVGE	AVGS[1:0]	Average number factor (AverageNum)
0	xx	1
1	00	4
1	01	8
1	10	16
1	11	32

Table 31-109. Base Conversion Time (BCT)

Mode	Base conversion time (BCT)
8b s.e.	17 ADCK cycles
9b diff	27 ADCK cycles
10b s.e.	20 ADCK cycles
11b diff	30 ADCK cycles
12b s.e.	20 ADCK cycles
13b diff	30 ADCK cycles
16b s.e.	25 ADCK cycles
16b diff	34 ADCK cycles

Table 31-110. Long sample time adder (LSTAdder)

ADLSMP	ADLSTS	Long sample time adder (LSTAdder)
0	xx	0 ADCK cycles
1	00	20 ADCK cycles
1	01	12 ADCK cycles
1	10	6 ADCK cycles
1	11	2 ADCK cycles

Table 31-111. High Speed Conversion time Adder (HSCAdder)

ADHSC	High Speed Conversion Time Adder (HSCAdder)
0	0 ADCK cycles
1	2 ADCK cycles

Note

The ADCK frequency must be between f_{ADCK} minimum and f_{ADCK} maximum to meet ADC specifications.

31.4.5.6 Conversion time examples

The following examples use [Figure 31-95](#) and the information provided in [Table 31-107](#) through [Table 31-111](#).

31.4.5.6.1 Typical conversion time configuration

A typical configuration for ADC conversion is: 10-bit mode, with the bus clock selected as the input clock source, the input clock divide-by-1 ratio selected, and a bus frequency of 8 MHz, long sample time disabled and high speed conversion disabled. The conversion time for a single conversion is calculated by using [Figure 31-95](#) and the information provided in [Table 31-107](#) through [Table 31-111](#). The table below list the variables of [Figure 31-95](#).

Table 31-112. Typical conversion time

Variable	Time
SFCAdder	5 ADCK cycles + 5 bus clock cycles
AverageNum	1
BCT	20 ADCK cycles
LSTAdder	0
HSCAdder	0

The resulting conversion time is generated using the parameters listed in the proceeding table. Therefore, for a bus clock equal to 8 MHz and an ADCK equal to 8 MHz the resulting conversion time is 3.75 μ s.

31.4.5.6.2 Long conversion time configuration

A configuration for long ADC conversion is: 16-bit differential mode with the bus clock selected as the input clock source, the input clock divide-by-8 ratio selected, a bus frequency of 8 MHz, long sample time enabled, configured for longest adder, high speed conversion disabled, and average enabled for 32 conversions. The conversion time for this conversion is calculated by using [Figure 31-95](#) and the information provided in [Table 31-107](#) through [Table 31-111](#). The following table lists the variables of the [Figure 31-95](#).

Table 31-113. Typical conversion time

Variable	Time
SFCAdder	3 ADCK cycles + 5 bus clock cycles
AverageNum	32
BCT	34 ADCK cycles
LSTAdder	20 ADCK cycles

Table continues on the next page...

Table 31-113. Typical conversion time (continued)

Variable	Time
HSCAdder	0

The resulting conversion time is generated using the parameters listed in the preceding table. Therefore, for bus clock equal to 8 MHz and ADCK equal to 1 MHz, the resulting conversion time is 57.625 μ s (AverageNum). This results in a total conversion time of 1.844 ms.

31.4.5.6.3 Short conversion time configuration

A configuration for short ADC conversion is: 8-bit single ended mode with the bus clock selected as the input clock source, the input clock divide-by-1 ratio selected, a bus frequency of 20 MHz, long sample time disabled, and high speed conversion enabled. The conversion time for this conversion is calculated by using [Figure 31-95](#) and the information provided in [Table 31-107](#) through [Table 31-111](#). The table below list the variables of [Figure 31-95](#).

Table 31-114. Typical conversion time

Variable	Time
SFCAdder	5 ADCK cycles + 5 bus clock cycles
AverageNum	1
BCT	17 ADCK cycles
LSTAdder	0 ADCK cycles
HSCAdder	2

The resulting conversion time is generated using the parameters listed in in the preceding table. Therefore, for bus clock equal to 20 MHz and ADCK equal to 20 MHz, the resulting conversion time is 1.45 μ s.

31.4.5.7 Hardware average function

The hardware average function can be enabled (AVGE=1) to perform a hardware average of multiple conversions. The number of conversions is determined by the AVGS[1:0] bits, which select 4, 8, 16, or 32 conversions to be averaged. While the hardware average function is in progress, the ADOVER bit will be set.

After the selected input is sampled and converted, the result is placed in an accumulator from which an average is calculated once the selected number of conversions has been completed. When hardware averaging is selected, the completion of a single conversion will not set the COCO bit.

If the compare function is either disabled or evaluates true, after the selected number of conversions are completed, the average conversion result is transferred into the data result registers, Rn, and the COCO bit is set. An ADC interrupt is generated upon the setting of COCO if the respective ADC interrupt is enabled (AIEN=1).

Note

The hardware average function can perform conversions on a channel while the MCU is in Wait or Normal Stop modes. The ADC interrupt wakes the MCU when the hardware average is completed if SC1n[AIEN] bit was set.

31.4.6 Automatic compare function

The compare function can be configured to check if the result is less than or greater-than-or-equal-to a single compare value, or if the result falls within or outside a range determined by two compare values. The compare mode is determined by ACFG, ACREN, and the values in the compare value registers (CV1 and CV2). After the input is sampled and converted, the compare values (CV1 and CV2) are used as described in the following table. There are six compare modes as shown in the following table.

Table 31-115. Compare modes

ACFG	ACREN	ADCCV1 relative to ADCCV2	Function	Compare mode description
0	0	—	Less than threshold	Compare true if the result is less than the CV1 registers.
1	0	—	Greater than or equal to threshold	Compare true if the result is greater than or equal to CV1 registers.
0	1	Less than or equal	Outside range, not inclusive	Compare true if the result is less than CV1 Or the result is greater than CV2.
0	1	Greater than	Inside range, not inclusive	Compare true if the result is less than CV1 And the result is greater than CV2.
1	1	Less than or equal	Inside range, inclusive	Compare true if the result is greater than or equal to CV1 And the result is less than or equal to CV2.
1	1	Greater than	Outside range, inclusive	Compare true if the result is greater than or equal to CV1 Or the result is less than or equal to CV2.

With the ADC range enable bit set, $ACREN = 1$, and if compare value register 1 (CV1 value) is less than or equal to the compare value register 2 (CV2 value), then setting ACFGT will select a trigger-if-inside-compare-range inclusive-of-endpoints function. Clearing ACFGT will select a trigger-if-outside-compare-range, not-inclusive-of-endpoints function.

If CV1 is greater than CV2, setting ACFGT will select a trigger-if-outside-compare-range, inclusive-of-endpoints function. Clearing ACFGT will select a trigger-if-inside-compare-range, not-inclusive-of-endpoints function.

If the condition selected evaluates true, COCO is set.

Upon completion of a conversion while the compare function is enabled, if the compare condition is not true, COCO is not set and the conversion result data will not be transferred to the result register. If the hardware averaging function is enabled, the compare function compares the averaged result to the compare values. The same compare function definitions apply. An ADC interrupt is generated upon the setting of COCO if the respective ADC interrupt is enabled ($AIEN=1$).

Note

The compare function can monitor the voltage on a channel while the MCU is in Wait or Normal Stop modes. The ADC interrupt wakes the MCU when the compare condition is met.

31.4.7 Calibration function

The ADC contains a self-calibration function that is required to achieve the specified accuracy. Calibration must be run, or valid calibration values written, after any reset and before a conversion is initiated. The calibration function sets the offset calibration value, the minus-side calibration values, and the plus-side calibration values. The offset calibration value is automatically stored in the ADC offset correction register (OFS), and the plus-side and minus-side calibration values are automatically stored in the ADC plus-side and minus-side calibration (CLPx and CLMx) registers. The user must configure the ADC correctly prior to calibration, and must generate the plus-side and minus-side gain calibration results and store them in the ADC plus-side gain register (PG) after the calibration function completes.

Prior to calibration, the user must configure the ADC's clock source and frequency, low power configuration, voltage reference selection, sample time, and high speed configuration according to the application's clock source availability and needs. If the application uses the ADC in a wide variety of configurations, the configuration for which the highest accuracy is required should be selected, or multiple calibrations can be done

for the different configurations. For best calibration results, it is recommended to set hardware averaging to maximum ($AVGE=1$, $AVGS=11$ for average of 32), ADC clock frequency f_{ADCK} less than or equal to 4 MHz, $V_{REFH}=V_{DDA}$, and to calibrate at nominal voltage and temperature. The input channel, conversion mode continuous function, compare function, resolution mode, and differential/single-ended mode are all ignored during the calibration function.

To initiate calibration, the user sets the CAL bit and the calibration will automatically begin if the ADTRG bit is 0. If ADTRG is 1, the CAL bit will not get set and the calibration fail flag (CALF) will be set. While calibration is active, no ADC register can be written and no stop mode may be entered, or the calibration routine will be aborted causing the CAL bit to clear and the CALF bit to set. At the end of a calibration sequence, the COCO bit of the SC1A register will be set. The AIEN bit can be used to allow an interrupt to occur at the end of a calibration sequence. At the end of the calibration routine, if the CALF bit is not set, the automatic calibration routine completed successfully.

To complete calibration, the user must generate the gain calibration values using the following procedure:

1. Initialize (clear) a 16-bit variable in RAM.
2. Add the plus-side calibration results CLP0, CLP1, CLP2, CLP3, CLP4, and CLPS to the variable.
3. Divide the variable by two.
4. Set the MSB of the variable.
5. The previous two steps can be achieved by setting the carry bit, rotating to the right through the carry bit on the high byte and again on the low byte.
6. Store the value in the plus-side gain calibration register (PG).
7. Repeat the procedure for the minus-side gain calibration value.

When calibration is complete, the user may reconfigure and use the ADC as desired. A second calibration may also be performed if desired by clearing and again setting the CAL bit.

Overall, the calibration routine may take as many as 14k ADCK cycles and 100 bus cycles, depending on the results and the clock source chosen. For an 8 MHz clock source, this length amounts to about 1.7 ms. To reduce this latency, the calibration values (offset, plus-side and minus-side gain, and plus-side and minus-side calibration values) may be

stored in flash memory after an initial calibration and recovered prior to the first ADC conversion. This method should reduce the calibration latency to 20 register store operations on all subsequent power, reset, or Low Power Stop mode recoveries.

31.4.8 User defined offset function

The ADC offset correction register (OFS) contains the user selected or calibration generated offset error correction value. This register is a 2's complement, left justified. The value in the offset correction register (OFS) is subtracted from the conversion and the result is transferred into the result registers (Rn). If the result is above the maximum or below the minimum result value, it is forced to the appropriate limit for the current mode of operation.

The formatting of the ADC offset correction register is different from the data result register (Rn) to preserve the resolution of the calibration value regardless of the conversion mode selected. Lower order bits are ignored in lower resolution modes. For example, in 8-bit single-ended mode, the bits OFS[14:7] are subtracted from D[7:0]; bit OFS[15] indicates the sign (negative numbers are effectively added to the result) and bits OFS[6:0] are ignored. The same bits are used in 9-bit differential mode since bit OFS[15] indicates the sign bit, which maps to bit D[8]. For 16-bit differential mode, all bits OFS[15:0] are directly subtracted from the conversion result data D[15:0]. In 16-bit single-ended mode, there is no bit in the offset correction register corresponding to the least significant result bit D[0], so odd values (-1 or +1, and so on) cannot be subtracted from the result.

OFS is automatically set according to calibration requirements once the self calibration sequence is done (CAL is cleared). The user may write to OFS to override the calibration result if desired. If the offset correction register is written by the user to a value that is different from the calibration value, the ADC error specifications may not be met. It is recommended that the value generated by the calibration function be stored in memory before overwriting with a user specified value.

Note

There is an effective limit to the values of offset that can be set by the user. If the magnitude of the offset is too great, the results of the conversions will cap off at the limits.

The offset calibration function may be employed by the user to remove application offsets or DC bias values. The offset correction register, OFS may be written with a number in 2's complement format and this offset will be subtracted from the result (or hardware averaged value). To add an offset, store the negative offset in 2's complement

format and the effect will be an addition. An offset correction that results in an out-of-range value will be forced to the minimum or maximum value (the minimum value for single-ended conversions is 0x0000; for a differential conversion it is 0x8000).

To preserve accuracy, the calibrated offset value initially stored in the OFS register must be added to the user defined offset. For applications that may change the offset repeatedly during operation, it is recommended to store the initial offset calibration value in flash so it can be recovered and added to any user offset adjustment value and the sum stored in the OFS register.

31.4.9 Temperature sensor

The ADC module includes a temperature sensor whose output is connected to one of the ADC analog channel inputs. The following equation provides an approximate transfer function of the temperature sensor.

$$\text{Temp} = 25 - \left(\left(V_{\text{TEMP}} - V_{\text{TEMP25}} \right) \div m \right)$$

Figure 31-96. Approximate transfer function of the temperature sensor

where:

- V_{TEMP} is the voltage of the temperature sensor channel at the ambient temperature.
- V_{TEMP25} is the voltage of the temperature sensor channel at 25 °C.
- m is the hot or cold voltage versus temperature slope in V/°C.

For temperature calculations, use the V_{TEMP25} and m values from the ADC Electricals table.

In application code, the user reads the temperature sensor channel, calculates V_{TEMP} , and compares to V_{TEMP25} . If V_{TEMP} is greater than V_{TEMP25} the cold slope value is applied in the preceding equation. If V_{TEMP} is less than V_{TEMP25} , the hot slope value is applied in the preceding equation.

For more information on using the temperature sensor, see the application note titled *Temperature Sensor for the HCS08 Microcontroller Family* (document AN3031).

31.4.10 MCU wait mode operation

Wait mode is a lower power-consumption standby mode from which recovery is fast because the clock sources remain active. If a conversion is in progress when the MCU enters Wait mode, it continues until completion. Conversions can be initiated while the MCU is in Wait mode by means of the hardware trigger or if continuous conversions are enabled.

The bus clock, bus clock divided by two, and ADACK are available as conversion clock sources while in Wait mode. The use of ALTCLK as the conversion clock source in Wait is dependent on the definition of ALTCLK for this MCU. Refer to the Chip Configuration information on ALTCLK specific to this MCU.

If the compare and hardware averaging functions are disabled, a conversion complete event sets the COCO and generates an ADC interrupt to wake the MCU from Wait mode if the respective ADC interrupt is enabled (AIEN=1). If the hardware averaging function is enabled, the COCO will set (and generate an interrupt if enabled) when the selected number of conversions are completed. If the compare function is enabled, the COCO will set (and generate an interrupt if enabled) only if the compare conditions are met. If a single conversion is selected and the compare trigger is not met, the ADC will return to its idle state and cannot wake the MCU from Wait mode unless a new conversion is initiated by the hardware trigger.

31.4.11 MCU Normal Stop mode operation

Stop mode is a low power-consumption standby mode during which most or all clock sources on the MCU are disabled.

31.4.11.1 Normal Stop mode with ADACK disabled

If the asynchronous clock, ADACK, is not selected as the conversion clock, executing a stop instruction aborts the current conversion and places the ADC in its idle state. The contents of the ADC registers, including Rn, are unaffected by Normal Stop mode. After exiting from Normal Stop mode, a software or hardware trigger is required to resume conversions.

31.4.11.2 Normal Stop mode with ADACK enabled

If ADACK is selected as the conversion clock, the ADC continues operation during Normal Stop mode. Refer to the Chip Configuration chapter for configuration information for this MCU.

If a conversion is in progress when the MCU enters Normal Stop mode, it continues until completion. Conversions can be initiated while the MCU is in Normal Stop mode by means of the hardware trigger or if continuous conversions are enabled.

If the compare and hardware averaging functions are disabled, a conversion complete event sets the COCO and generates an ADC interrupt to wake the MCU from Normal Stop mode if the respective ADC interrupt is enabled (AIEN = 1). The result register will contain the data from the first completed conversion that occurred during Normal Stop mode. If the hardware averaging function is enabled, the COCO will set (and generate an interrupt if enabled) when the selected number of conversions are completed. If the compare function is enabled, the COCO will set (and generate an interrupt if enabled) only if the compare conditions are met. If a single conversion is selected and the compare is not true, the ADC will return to its idle state and cannot wake the MCU from Normal Stop mode unless a new conversion is initiated by another hardware trigger.

31.4.12 MCU Low Power Stop mode operation

The ADC module is automatically disabled when the MCU enters Low Power Stop mode. All module registers contain their reset values following exit from Low Power Stop mode. Therefore, the module must be re-enabled and re-configured following exit from Low Power Stop mode.

NOTE

For the chip specific modes of operation, refer to the Power Management information for the device.

31.5 Initialization information

This section gives an example that provides some basic direction on how to initialize and configure the ADC module. You can configure the module for 16-bit, 12-bit, 10-bit, or 8-bit single-ended resolution or 16-bit, 13-bit, 11-bit, or 9-bit differential resolution, single or continuous conversion, and a polled or interrupt approach, among many other options. Refer to [Table 31-110](#), [Table 31-111](#), and [Table 31-112](#) for information used in this example.

Note

Hexadecimal values are designated by a preceding 0x, binary values designated by a preceding %, and decimal values have no preceding character.

31.5.1 ADC module initialization example

This section provides details about the ADC module initialization.

31.5.1.1 Initialization sequence

Before the ADC module can be used to complete conversions, an initialization procedure must be performed. A typical sequence is as follows:

1. Calibrate the ADC by following the calibration instructions in [Calibration function](#).
2. Update the configuration register (CFG) to select the input clock source and the divide ratio used to generate the internal clock, ADCK. This register is also used for selecting sample time and low-power configuration.
3. Update status and control register 2 (SC2) to select the conversion trigger (hardware or software) and compare function options, if enabled.
4. Update status and control register 3 (SC3) to select whether conversions will be continuous or completed only once (ADCO) and to select whether to perform hardware averaging.
5. Update the status and control register (SC1:SC1n) to select whether conversions will be single-ended or differential and to enable or disable conversion complete interrupts. Also, select the input channel on which to perform conversions.
6. Update PGA register (PGA) to enable or disable PGA and configure appropriate gain. This register is also used for selecting power mode and whether the module is chopper stabilized.

31.5.1.2 Pseudo-code example

In this example, the ADC module is set up with interrupts enabled to perform a single 10-bit conversion at low power with a long sample time on input channel 1, where the internal ADCK clock is derived from the bus clock divided by 1.

Initialization information

CFG1 = 0x98 (%10011000)

Bit 7	ADLPC	1	Configures for low power (lowers maximum clock speed.
Bit 6:5	ADIV	00	Sets the ADCK to the input clock ÷ 1.
Bit 4	ADLSMP	1	Configures for long sample time.
Bit 3:2	MODE	10	Selects the single-ended 10-bit conversion, differential 11-bit conversion.
Bit 1:0	ADICLK	00	Selects the bus clock.

SC2 = 0x00 (%00000000)

Bit 7	ADACT	0	Flag indicates if a conversion is in progress.
Bit 6	ADTRG	0	Software trigger selected.
Bit 5	ACFE	0	Compare function disabled.
Bit 4	ACFGT	0	Not used in this example.
Bit 3	ACREN	0	Compare range disabled.
Bit 2	DMAEN	0	DMA request disabled.
Bit 1:0	REFSEL	00	Selects default voltage reference pin pair (External pins V_{REFH} and V_{REFL}).

SC1A = 0x41 (%01000001)

Bit 7	COCO	0	Read-only flag which is set when a conversion completes.
Bit 6	AIEN	1	Conversion complete interrupt enabled.
Bit 5	DIFF	0	Single-ended conversion selected.
Bit 4:0	ADCH	00001	Input channel 1 selected as ADC input channel.

RA = 0xxx

Holds results of conversion.

CV = 0xxx

Holds compare value when compare function enabled.

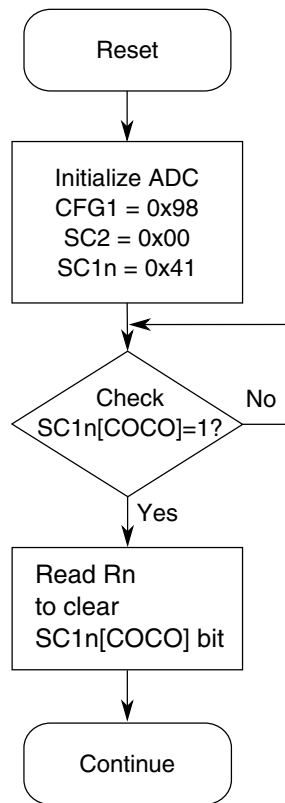

Figure 31-97. Initialization Flowchart for Example

31.6 Application information

This section contains information for using the ADC module in applications. The ADC has been designed to be integrated into a microcontroller for use in embedded control applications requiring an ADC.

31.6.1 External pins and routing

The following sections discuss the external pins associated with the ADC module and how they should be used for best results.

31.6.1.1 Analog supply pins

The ADC module has analog power and ground supplies (V_{DDA} and V_{SSA}) available as separate pins on some devices. V_{SSA} is shared on the same pin as the MCU digital VSS on some devices. On other devices, V_{SSA} and V_{DDA} are shared with the MCU digital

supply pins. In these cases, there are separate pads for the analog supplies bonded to the same pin as the corresponding digital supply so that some degree of isolation between the supplies is maintained.

When available on a separate pin, both V_{DDA} and V_{SSA} must be connected to the same voltage potential as their corresponding MCU digital supply (V_{DD} and V_{SS}) and must be routed carefully for maximum noise immunity and bypass capacitors placed as near as possible to the package.

If separate power supplies are used for analog and digital power, the ground connection between these supplies must be at the V_{SSA} pin. This should be the only ground connection between these supplies if possible. The V_{SSA} pin makes a good single point ground location.

31.6.1.2 Analog voltage reference pins

In addition to the analog supplies, the ADC module has connections for two reference voltage inputs used by the converter, V_{REFSH} and V_{REFSL} . V_{REFSH} is the high reference voltage for the converter. V_{REFSL} is the low reference voltage for the converter.

The ADC can be configured to accept one of two voltage reference pairs for V_{REFSH} and V_{REFSL} . Each pair contains a positive reference and a ground reference. The two pairs are external (V_{REFH} and V_{REFL}) and alternate (V_{ALTH} and V_{ALTTL}). These voltage references are selected using the REFSEL bits in the SC2 register. The alternate (V_{ALTH} and V_{ALTTL}) voltage reference pair may select additional external pins or internal sources depending on MCU configuration. Refer to the Chip Configuration information on the Voltage References specific to this MCU.

In some packages, the external or alternate pairs are connected in the package to V_{DDA} and V_{SSA} , respectively. One of these positive references may be shared on the same pin as V_{DDA} on some devices. One of these ground references may be shared on the same pin as V_{SSA} on some devices.

If externally available, the positive reference may be connected to the same potential as V_{DDA} or may be driven by an external source to a level between the minimum Ref Voltage High and the V_{DDA} potential (the positive reference must never exceed V_{DDA}). If externally available, the ground reference must be connected to the same voltage potential as V_{SSA} . The voltage reference pairs must be routed carefully for maximum noise immunity and bypass capacitors placed as near as possible to the package.

AC current in the form of current spikes required to supply charge to the capacitor array at each successive approximation step is drawn through the V_{REFH} and V_{REFL} loop. The best external component to meet this current demand is a 0.1 μF capacitor with good high

frequency characteristics. This capacitor is connected between V_{REFH} and V_{REFL} and must be placed as near as possible to the package pins. Resistance in the path is not recommended because the current causes a voltage drop that could result in conversion errors. Inductance in this path must be minimum (parasitic only).

31.6.1.3 Analog input pins

The external analog inputs are typically shared with digital I/O pins on MCU devices.

Empirical data shows that capacitors on the analog inputs improve performance in the presence of noise or when the source impedance is high. Use of 0.01 μF capacitors with good high-frequency characteristics is sufficient. These capacitors are not necessary in all cases, but when used they must be placed as near as possible to the package pins and be referenced to V_{SSA} .

For proper conversion, the input voltage must fall between V_{REFH} and V_{REFL} . If the input is equal to or exceeds V_{REFH} , the converter circuit converts the signal to 0xFFF (full scale 12-bit representation), 0x3FF (full scale 10-bit representation) or 0xFF (full scale 8-bit representation). If the input is equal to or less than V_{REFL} , the converter circuit converts it to 0x000. Input voltages between V_{REFH} and V_{REFL} are straight-line linear conversions. There is a brief current associated with V_{REFL} when the sampling capacitor is charging.

For minimal loss of accuracy due to current injection, pins adjacent to the analog input pins should not be transitioning during conversions.

31.6.2 Sources of error

Several sources of error exist for A/D conversions. These are discussed in the following sections.

31.6.2.1 Sampling error

For proper conversions, the input must be sampled long enough to achieve the proper accuracy.

$$RAS + RADIN = SC / (FMAX * NUMTAU * CADIN)$$

Figure 31-98. Sampling equation

Where:

RAS = External analog source resistance

SC = Number of ADCK cycles used during sample window

CADIN = Internal ADC input capacitance

NUMTAU = $-\ln(\text{LSBERR} / 2^N)$

LSBERR = value of acceptable sampling error in LSBs

N = 8 in 8-bit mode, 10 in 10-bit mode, 12 in 12-bit mode or 16 in 16-bit mode

Higher source resistances or higher-accuracy sampling is possible by setting ADLSMP and changing the ADLSTS bits (to increase the sample window) or decreasing ADCK frequency to increase sample time.

31.6.2.2 Pin leakage error

Leakage on the I/O pins can cause conversion error if the external analog source resistance (R_{AS}) is high. If this error cannot be tolerated by the application, keep R_{AS} lower than $V_{REFH} / (4 \times I_{LEAK} \times 2^N)$ for less than 1/4 LSB leakage error (N = 8 in 8-bit mode, 10 in 10-bit mode, 12 in 12-bit mode, or 16 in 16-bit mode).

31.6.2.3 Noise-induced errors

System noise that occurs during the sample or conversion process can affect the accuracy of the conversion. The ADC accuracy numbers are guaranteed as specified only if the following conditions are met:

- There is a 0.1 μF low-ESR capacitor from V_{REFH} to V_{REFL} .
- There is a 0.1 μF low-ESR capacitor from V_{DDA} to V_{SSA} .
- If inductive isolation is used from the primary supply, an additional 1 μF capacitor is placed from V_{DDA} to V_{SSA} .
- V_{SSA} (and V_{REFL} , if connected) is connected to V_{SS} at a quiet point in the ground plane.
- Operate the MCU in Wait or Normal Stop mode before initiating (hardware triggered conversions) or immediately after initiating (hardware or software triggered conversions) the ADC conversion.

- For software triggered conversions, immediately follow the write to the SC1 register with a wait instruction or stop instruction.
- For Normal Stop mode operation, select ADACK as the clock source. Operation in Normal Stop reduces V_{DD} noise but increases effective conversion time due to stop recovery.
- There is no I/O switching, input or output, on the MCU during the conversion.

There are some situations where external system activity causes radiated or conducted noise emissions or excessive V_{DD} noise is coupled into the ADC. In these situations, or when the MCU cannot be placed in Wait or Normal Stop or I/O activity cannot be halted, these recommended actions may reduce the effect of noise on the accuracy:

- Place a 0.01 μF capacitor (C_{AS}) on the selected input channel to V_{REFL} or V_{SSA} (this improves noise issues, but affects the sample rate based on the external analog source resistance).
- Average the result by converting the analog input many times in succession and dividing the sum of the results. Four samples are required to eliminate the effect of a 1 LSB, one-time error.
- Reduce the effect of synchronous noise by operating off the asynchronous clock (ADACK) and averaging. Noise that is synchronous to ADCK cannot be averaged out.

31.6.2.4 Code width and quantization error

The ADC quantizes the ideal straight-line transfer function into 65536 steps (in 16-bit mode). Each step ideally has the same height (1 code) and width. The width is defined as the delta between the transition points to one code and the next. The ideal code width for an N bit converter (in this case N can be 16, 12, 10, or 8), defined as 1 LSB, is:

$$1\text{LSB} = (V_{REFH}) / 2^N$$

Figure 31-99. Ideal code width for an N bit converter

There is an inherent quantization error due to the digitization of the result. For 8-bit, 10-bit, or 12-bit conversions, the code transitions when the voltage is at the midpoint between the points where the straight line transfer function is exactly represented by the actual transfer function. Therefore, the quantization error will be $\pm 1/2$ LSB in 8-bit, 10-bit, or 12-bit modes. As a consequence, however, the code width of the first (0x000) conversion is only 1/2 LSB and the code width of the last (0xFF or 0x3FF) is 1.5 LSB.

For 16-bit conversions, the code transitions only after the full code width is present, so the quantization error is -1 LSB to 0 LSB and the code width of each step is 1 LSB.

31.6.2.5 Linearity errors

The ADC may also exhibit non-linearity of several forms. Every effort has been made to reduce these errors, but the system designers should be aware of them because they affect overall accuracy. These errors are:

- Zero-scale error (E_{ZS}) (sometimes called offset): This error is defined as the difference between the actual code width of the first conversion and the ideal code width (1/2 LSB in 8-bit, 10-bit, or 12-bit modes and 1 LSB in 16-bit mode). If the first conversion is 0x001, the difference between the actual 0x001 code width and its ideal (1 LSB) is used.
- Full-scale error (E_{FS}): This error is defined as the difference between the actual code width of the last conversion and the ideal code width (1.5 LSB in 8-bit, 10-bit, or 12-bit modes and 1 LSB in 16-bit mode). If the last conversion is 0x3FE, the difference between the actual 0x3FE code width and its ideal (1 LSB) is used.
- Differential non-linearity (DNL): This error is defined as the worst-case difference between the actual code width and the ideal code width for all conversions.
- Integral non-linearity (INL): This error is defined as the highest-value the (absolute value of the) running sum of DNL achieves. More simply, this is the worst-case difference of the actual transition voltage to a given code and its corresponding ideal transition voltage, for all codes.
- Total unadjusted error (TUE): This error is defined as the difference between the actual transfer function and the ideal straight-line transfer function and includes all forms of error.

31.6.2.6 Code jitter, non-monotonicity, and missing codes

Analog-to-digital converters are susceptible to three special forms of error. These are code jitter, non-monotonicity, and missing codes.

Code jitter is when, at certain points, a given input voltage converts to one of two values when sampled repeatedly. Ideally, when the input voltage is infinitesimally smaller than the transition voltage, the converter yields the lower code (and vice-versa). However, even small amounts of system noise can cause the converter to be indeterminate (between two codes) for a range of input voltages around the transition voltage.

This error may be reduced by repeatedly sampling the input and averaging the result. Additionally, the techniques discussed in [Noise-induced errors](#) reduces this error.

Non-monotonicity is defined as when, except for code jitter, the converter converts to a lower code for a higher input voltage. Missing codes are those values never converted for any input value.

In 8-bit or 10-bit mode, the ADC is guaranteed to be monotonic and have no missing codes.

Chapter 32

Comparator (CMP)

32.1 Introduction

NOTE

For the chip-specific implementation details of this module's instances see the chip configuration chapter.

The Comparator module (CMP) provides a circuit for comparing two analog input voltages. The comparator circuit is designed to operate across the full range of the supply voltage (rail to rail operation).

The Analog MUX (ANMUX) provides a circuit for selecting an analog input signal from eight channels. One signal provided by the 6-bit DAC. The mux circuit is designed to operate across the full range of the supply voltage.

The 6-bit DAC is 64-tap resistor ladder network which provides a selectable voltage reference for applications where voltage reference is needed. The 64-tap resistor ladder network divides the supply reference V_{in} into 64 voltage level. A 6-bit digital signal input selects output voltage level, which varies from V_{in} to $V_{in}/64$. V_{in} can be selected from two voltage sources, V_{in1} and V_{in2} . The 6-bit DAC from a comparator is available as an on-chip internal signal only and is not available externally to a pin.

32.2 CMP Features

The CMP has the following features:

- Operates over the entire supply range
- Inputs may range from rail to rail
- Programmable hysteresis control

32.3.1 DAC Key Features

- Selectable interrupt on rising edge, falling edge, or both rising or falling edges of comparator output
- Selectable inversion on comparator output
- Comparator output may be:
 - Sampled
 - Windowed (ideal for certain PWM zero-crossing-detection applications)
 - Digitally Filtered
 - Filter can be bypassed
 - Can be clocked via external SAMPLE signal or scaled bus clock
- External hysteresis can be used at the same time that the output filter is used for internal functions.
- Two software selectable performance levels:
 - Shorter propagation delay at the expense of higher power
 - Low power, with longer propagation delay
- Support DMA transfer
 - A comparison event can be selected to trigger a DMA transfer.
- Functional in all modes of operation.
- The window and filter functions are not available in Stop, VLPS, LLS and VLLSx modes.

32.3 6-bit DAC Key Features

- 6-bit resolution
- Selectable supply reference source
- Power down mode to conserve power when it is not being used
- Output can be routed to internal comparator input

32.4 ANMUX Key Features

- Two 8 to 1 channel mux
- Operates the entire supply range

32.5 CMP, DAC, and ANMUX Diagram

The following figure shows the block diagram for the High Speed Comparator, Digital to Analog Converter, and Analog MUX modules.

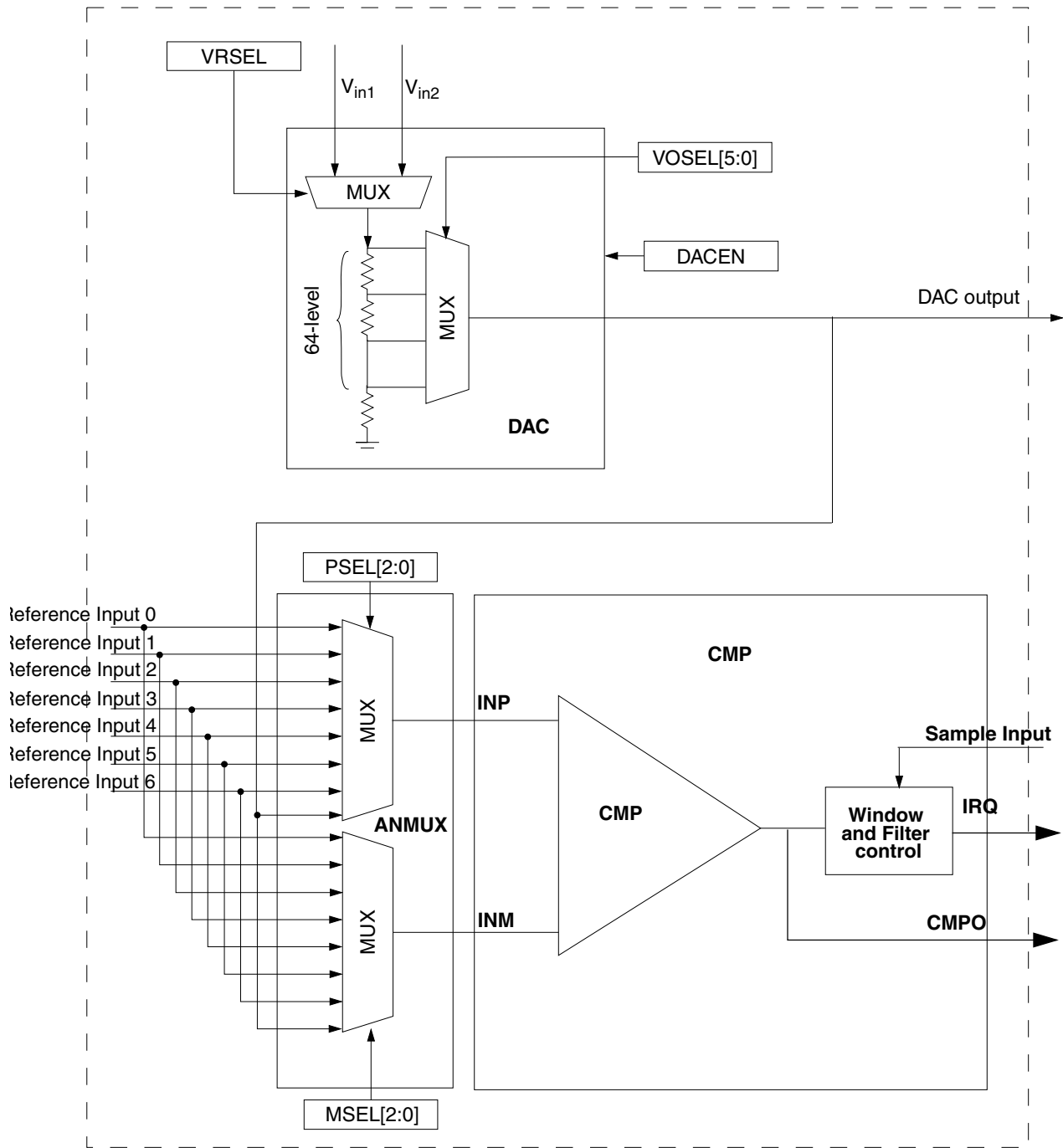

Figure 32-1. CMP, DAC and ANMUX Blocks Diagram

32.6 CMP Block Diagram

The following figure shows the block diagram for the Comparator module.

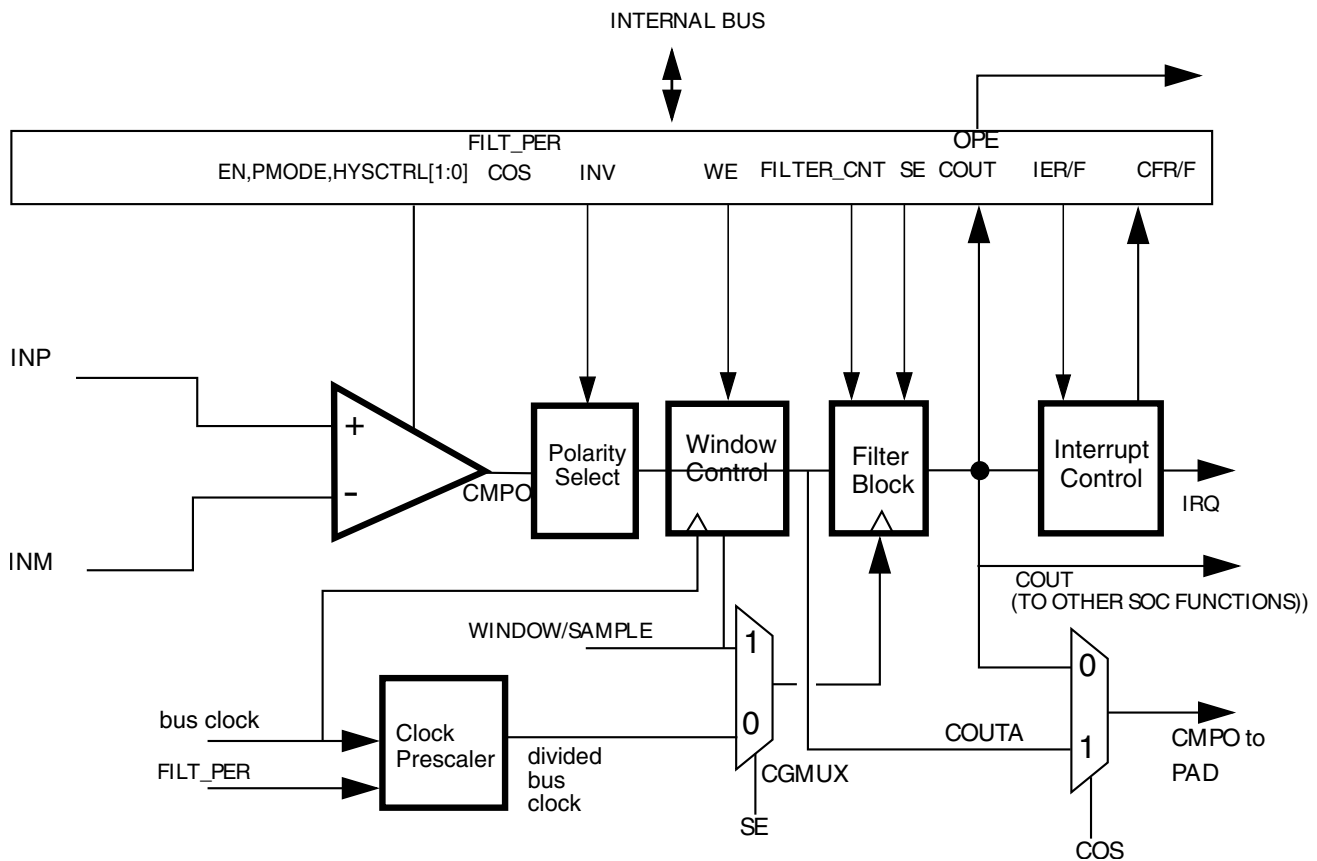

Figure 32-2. Comparator Module Block Diagram

In the CMP block diagram:

- The Window Control block is bypassed when $CR1[WE] = 0$
- If $CR1[WE] = 1$, the comparator output will be sampled on every bus clock when $WINDOW=1$ to generate $COUTA$. Sampling does NOT occur when $WINDOW = 0$.
- The Filter Block is bypassed when not in use.
- The Filter Block acts as a simple sampler if the filter is bypassed and $CR0[FILTER_CNT]$ is set to $0x01$.
- The Filter Block filters based on multiple samples when the filter is bypassed and $CR0[FILTER_CNT]$ is set greater than $0x01$.
 - If $CR1[SE] = 1$, the external $SAMPLE$ input is used as sampling clock
 - IF $CR1[SE] = 0$, the divided bus clock is used as sampling clock

- If enabled, the Filter Block will incur up to 1 bus clock additional latency penalty on COUT due to the fact that COUT (which is crossing clock domain boundaries) must be resynchronized to the bus clock.
- CR1[WE] and CR1[SE] are mutually exclusive.

32.7 Memory Map/Register Definitions

CMP memory map

Absolute address (hex)	Register name	Width (in bits)	Access	Reset value	Section/page
4007_3000	CMP Control Register 0 (CMP0_CR0)	8	R/W	00h	32.7.1/729
4007_3001	CMP Control Register 1 (CMP0_CR1)	8	R/W	00h	32.7.2/730
4007_3002	CMP Filter Period Register (CMP0_FPR)	8	R/W	00h	32.7.3/731
4007_3003	CMP Status and Control Register (CMP0_SCR)	8	R/W	00h	32.7.4/732
4007_3004	DAC Control Register (CMP0_DACCR)	8	R/W	00h	32.7.5/733
4007_3005	MUX Control Register (CMP0_MUXCR)	8	R/W	00h	32.7.6/734
4007_3008	CMP Control Register 0 (CMP1_CR0)	8	R/W	00h	32.7.1/729
4007_3009	CMP Control Register 1 (CMP1_CR1)	8	R/W	00h	32.7.2/730
4007_300A	CMP Filter Period Register (CMP1_FPR)	8	R/W	00h	32.7.3/731
4007_300B	CMP Status and Control Register (CMP1_SCR)	8	R/W	00h	32.7.4/732
4007_300C	DAC Control Register (CMP1_DACCR)	8	R/W	00h	32.7.5/733
4007_300D	MUX Control Register (CMP1_MUXCR)	8	R/W	00h	32.7.6/734
4007_3010	CMP Control Register 0 (CMP2_CR0)	8	R/W	00h	32.7.1/729
4007_3011	CMP Control Register 1 (CMP2_CR1)	8	R/W	00h	32.7.2/730

Table continues on the next page...

CMP memory map (continued)

Absolute address (hex)	Register name	Width (in bits)	Access	Reset value	Section/page
4007_3012	CMP Filter Period Register (CMP2_FPR)	8	R/W	00h	32.7.3/731
4007_3013	CMP Status and Control Register (CMP2_SCR)	8	R/W	00h	32.7.4/732
4007_3014	DAC Control Register (CMP2_DACCR)	8	R/W	00h	32.7.5/733
4007_3015	MUX Control Register (CMP2_MUXCR)	8	R/W	00h	32.7.6/734

32.7.1 CMP Control Register 0 (CMPx_CR0)

Addresses: CMP0_CR0 is 4007_3000h base + 0h offset = 4007_3000h

CMP1_CR0 is 4007_3008h base + 0h offset = 4007_3008h

CMP2_CR0 is 4007_3010h base + 0h offset = 4007_3010h

Bit	7	6	5	4	3	2	1	0
Read	0	FILTER_CNT			0	0	HYSTCTR	
Write	[Shaded]			[Shaded]			[Shaded]	
Reset	0	0	0	0	0	0	0	0

CMPx_CR0 field descriptions

Field	Description
7 Reserved	This read-only field is reserved and always has the value zero.
6–4 FILTER_CNT	<p>Filter Sample Count</p> <p>These bits represent the number of consecutive samples that must agree prior to the comparator output filter accepting a new output state. For information regarding filter programming and latency reference the Functional Description.</p> <p>000 Filter is disabled. If SE = 1, then COUT is a logic zero (this is not a legal state, and is not recommended). If SE = 0, COUT = COUTA.</p> <p>001 1 consecutive sample must agree (comparator output is simply sampled).</p> <p>010 2 consecutive samples must agree.</p> <p>011 3 consecutive samples must agree.</p> <p>100 4 consecutive samples must agree.</p> <p>101 5 consecutive samples must agree.</p> <p>110 6 consecutive samples must agree.</p> <p>111 7 consecutive samples must agree.</p>
3 Reserved	This read-only field is reserved and always has the value zero.

Table continues on the next page...

CMPx_CR0 field descriptions (continued)

Field	Description
2 Reserved	This read-only field is reserved and always has the value zero.
1-0 HYSTCTR	<p>Comparator hard block hysteresis control</p> <p>Defines the programmable hysteresis level. The hysteresis values associated with each level is device-specific. See the device's data sheet for the exact values.</p> <p>00 Level 0 01 Level 1 10 Level 2 11 Level 3</p>

32.7.2 CMP Control Register 1 (CMPx_CR1)

Addresses: CMP0_CR1 is 4007_3000h base + 1h offset = 4007_3001h

CMP1_CR1 is 4007_3008h base + 1h offset = 4007_3009h

CMP2_CR1 is 4007_3010h base + 1h offset = 4007_3011h

Bit	7	6	5	4	3	2	1	0
Read	SE	WE	0	PMODE	INV	COS	OPE	EN
Write								
Reset	0	0	0	0	0	0	0	0

CMPx_CR1 field descriptions

Field	Description
7 SE	<p>Sample Enable</p> <p>At any given time, either SE or WE can be set. If a write to this register attempts to set both, then SE is set and WE is cleared. However, avoid writing ones to both bit locations because this "11" case is reserved and may change in future implementations.</p> <p>0 Sampling mode not selected. 1 Sampling mode selected.</p>
6 WE	<p>Windowing Enable</p> <p>At any given time, either SE or WE can be set. If a write to this register attempts to set both, then SE is set and WE is cleared. However, avoid writing ones to both bit locations because this "11" case is reserved and may change in future implementations.</p> <p>0 Windowing mode not selected. 1 Windowing mode selected.</p>
5 Reserved	This read-only field is reserved and always has the value zero.
4 PMODE	Power Mode Select

Table continues on the next page...

CMPx_CR1 field descriptions (continued)

Field	Description
	Refer to the device data sheet's CMP electrical specifications table for details on the impact of the modes below. 0 Low Speed (LS) comparison mode selected. In this mode, CMP has slower output propagation delay and lower current consumption. 1 High Speed (HS) comparison mode selected. In this mode, CMP has faster output propagation delay and higher current consumption.
3 INV	Comparator INVERT This bit allows you to select the polarity of the analog comparator function. It is also driven to the COUT output (on both the device pin and as SCR[COUT]) when CR1[OPE]=0. 0 Does not invert the comparator output. 1 Inverts the comparator output.
2 COS	Comparator Output Select 0 Set CMPO to equal COUT (filtered comparator output). 1 Set CMPO to equal COUTA (unfiltered comparator output).
1 OPE	Comparator Output Pin Enable 0 The comparator output (CMPO) is not available on the associated CMPO output pin. 1 The comparator output (CMPO) is available on the associated CMPO output pin.
0 EN	Comparator Module Enable The EN bit enables the Analog Comparator Module. When the module is not enabled, it remains in the off state, and consumes no power. When you select the same input from analog mux to the positive and negative port, the comparator is disabled automatically. NOTE: This bit must be set in the same time with or after the mux enables (MUXCR[PEN] and MUXCR[MEM] are set) and should be neglected in the same time or before the mux enables. 0 Analog Comparator disabled. 1 Analog Comparator enabled.

32.7.3 CMP Filter Period Register (CMPx_FPR)

Addresses: CMP0_FPR is 4007_3000h base + 2h offset = 4007_3002h

CMP1_FPR is 4007_3008h base + 2h offset = 4007_300Ah

CMP2_FPR is 4007_3010h base + 2h offset = 4007_3012h

Bit	7	6	5	4	3	2	1	0
Read	FILT_PER							
Write	FILT_PER							
Reset	0	0	0	0	0	0	0	0

CMPx_FPR field descriptions

Field	Description
7-0 FILT_PER	<p>Filter Sample Period</p> <p>When CR1[SE] is equal to zero, this field specifies the sampling period, in bus clock cycles, of the comparator output filter. Setting FILT_PER to 0x0 disables the filter. Filter programming and latency details appear in the Functional Description.</p> <p>This field has no effect when CR1[SE] is equal to one. In that case, the external SAMPLE signal is used to determine the sampling period.</p>

32.7.4 CMP Status and Control Register (CMPx_SCR)

Addresses: CMP0_SCR is 4007_3000h base + 3h offset = 4007_3003h

CMP1_SCR is 4007_3008h base + 3h offset = 4007_300Bh

CMP2_SCR is 4007_3010h base + 3h offset = 4007_3013h

Bit	7	6	5	4	3	2	1	0
Read	0	DMAEN	SMELB	IER	IEF	CFR	CFF	COUT
Write						w1c	w1c	
Reset	0	0	0	0	0	0	0	0

CMPx_SCR field descriptions

Field	Description
7 Reserved	This read-only field is reserved and always has the value zero.
6 DMAEN	<p>DMA Enable Control</p> <p>The DMAEN bit enables the DMA transfer triggered from the CMP module. When this bit is set, a DMA request is asserted when the CFR or CFF bit is set.</p> <p>0 DMA disabled. 1 DMA enabled.</p>
5 SMELB	<p>Stop Mode Edge/Level Interrupt Control</p> <p>This bit controls whether the CFR and CFF bits are edge sensitive or level sensitive in Stop mode.</p> <p>NOTE: This bit should always be programmed to 0 to keep the comparator working and to wake up the MCU.</p> <p>0 CFR/CFF are level sensitive in Stop mode. CFR will be asserted when COUT is high. CFF will be asserted when COUT is low. 1 CFR/CFF are edge sensitive in Stop mode. An active low-to-high transition must be seen on COUT to assert CFR, and an active high-to-low transition must be seen on COUT to assert CFF.</p>
4 IER	<p>Comparator Interrupt Enable Rising</p> <p>The IER bit enables the CFR interrupt from the CMP. When this bit is set, an interrupt will be asserted when the CFR bit is set.</p>

Table continues on the next page...

CMPx_SCR field descriptions (continued)

Field	Description
	0 Interrupt disabled. 1 Interrupt enabled.
3 IEF	Comparator Interrupt Enable Falling The IEF bit enables the CFF interrupt from the CMP. When this bit is set, an interrupt will be asserted when the CFF bit is set. 0 Interrupt disabled. 1 Interrupt enabled.
2 CFR	Analog Comparator Flag Rising During normal operation, the CFR bit is set when a rising edge on COUT has been detected. The CFR bit is cleared by writing a logic one to the bit. During Stop modes, CFR can be programmed as either edge or level sensitive via the SMELB bit. NOTE: Edge detection during Stop mode is only supported on platforms that allow peripherals to be clocked during Stop modes. If the CFR flag is active during Stop mode, then SMELB must be set to 0 for cases where it is not receiving a clock during Stop mode. 0 Rising edge on COUT has not been detected. 1 Rising edge on COUT has occurred.
1 CFF	Analog Comparator Flag Falling During normal operation, the CFF bit is set when a falling edge on COUT has been detected. The CFF bit is cleared by writing a logic one to the bit. During Stop modes, CFF can be programmed as either edge or level sensitive via the SMELB bit. NOTE: Edge detection during Stop mode is only supported on platforms that allow peripherals to be clocked during Stop modes. If the CFF flag is active during Stop mode, then SMELB must be set to 0 for cases where it is not receiving a clock during Stop mode. 0 Falling edge on COUT has not been detected. 1 Falling edge on COUT has occurred.
0 COUT	Analog Comparator Output Reading the COUT bit will return the current value of the analog comparator output. The register bit is reset to zero and will read as CR1[INV] when the Analog Comparator module is disabled (CR1[EN] = 0). Writes to this bit are ignored.

32.7.5 DAC Control Register (CMPx_DACCR)

Addresses: CMP0_DACCR is 4007_3000h base + 4h offset = 4007_3004h
 CMP1_DACCR is 4007_3008h base + 4h offset = 4007_300Ch
 CMP2_DACCR is 4007_3010h base + 4h offset = 4007_3014h

Bit	7	6	5	4	3	2	1	0
Read	DACEN		VRSEL		VOSEL			
Write	DACEN		VRSEL		VOSEL			
Reset	0	0	0	0	0	0	0	0

CMPx_DACCR field descriptions

Field	Description
7 DACEN	<p>DAC Enable</p> <p>This bit is used to enable the DAC. When the DAC is disabled, it is powered down to conserve power.</p> <p>0 DAC is disabled. 1 DAC is enabled.</p>
6 VRSEL	<p>Supply Voltage Reference Source Select</p> <p>0 V_{in1} is selected as resistor ladder network supply reference V_{in}. 1 V_{in2} is selected as resistor ladder network supply reference V_{in}.</p>
5-0 VOSEL	<p>DAC Output Voltage Select</p> <p>This bit selects an output voltage from one of 64 distinct levels.</p> <p>$DACO = (V_{in}/64) * (VOSEL[5:0] + 1)$, so the DACO range is from $V_{in}/64$ to V_{in}.</p>

32.7.6 MUX Control Register (CMPx_MUXCR)

PEN and MEN bits should be enabled or disabled together with CR1[EN] bit.

Addresses: CMP0_MUXCR is 4007_3000h base + 5h offset = 4007_3005h

CMP1_MUXCR is 4007_3008h base + 5h offset = 4007_300Dh

CMP2_MUXCR is 4007_3010h base + 5h offset = 4007_3015h

Bit	7	6	5	4	3	2	1	0
Read								
Write	PEN	MEN	PSEL			MSEL		
Reset	0	0	0	0	0	0	0	0

CMPx_MUXCR field descriptions

Field	Description
7 PEN	<p>PMUX Enable</p> <p>This bit is used to enable positive MUX. When the PMUX is disabled, the PMUX output is in a high impedance state. When software selects the same input for plus and minus inputs of the comparator, both PMUX and MMUX are disabled automatically.</p> <p>0 PMUX is disabled. 1 PMUX is enabled.</p>
6 MEN	<p>MMUX Enable</p> <p>This bit is used to enable negative MUX. When the MMUX is disabled, the MMUX output is in a high impedance state. When software selects the same input for plus and minus inputs of the comparator, both PMUX and MMUX are disabled automatically.</p> <p>0 MMUX is disabled. 1 MMUX is enabled.</p>

Table continues on the next page...

CMPx_MUXCR field descriptions (continued)

Field	Description
5–3 PSEL	<p>Plus Input MUX Control</p> <p>Determines which input is selected for the plus input of the comparator. For INx inputs, refer to CMP, DAC and ANMUX Blocks Diagram.</p> <p>NOTE: When an inappropriate operation selects the same input for both MUXes, the comparator automatically shuts down to prevent itself from becoming a noise generator.</p> <p>000 IN0 001 IN1 010 IN2 011 IN3 100 IN4 101 IN5 110 IN6 111 IN7</p>
2–0 MSEL	<p>Minus Input MUX Control</p> <p>Determines which input is selected for the minus input of the comparator. For INx inputs, refer to CMP, DAC and ANMUX Blocks Diagram.</p> <p>NOTE: When an inappropriate operation selects the same input for both MUXes, the comparator automatically shuts down to prevent itself from becoming a noise generator.</p> <p>000 IN0 001 IN1 010 IN2 011 IN3 100 IN4 101 IN5 110 IN6 111 IN7</p>

32.8 CMP Functional Description

The Comparator can be used to compare two analog input voltages applied to INP and INM. The analog comparator output (CMPO) is high when the non-inverting input is greater than the inverting input, and is low when the non-inverting input is less than the inverting input. This signal can be selectively inverted by setting CR1[INV] = 1.

The SCR[IER], SCR[IEF], and SCR[SMELB] bits are used to select the condition which will cause the comparator module to assert an interrupt to the processor. SCR[CFF] is set on a falling edge and SCR[CFR] is set on rising edge of the comparator output. The (optionally filtered) comparator output can be read directly through the SCR[COU] bit.

32.8.1 CMP Functional Modes

There are three main sub-blocks to the comparator module: the comparator itself, the window function and the filter function. The filter, CR0[FILTER_CNT] can be clocked from an internally or external clock source. Additionally, the filter is programmable with respect to how many samples must agree before a change on the output is registered. In the simplest case, only 1 sample must agree. In this case, the filter acts as a simple sampler.

The external sample input is enabled using CR1[SE]. When set, the output of the comparator is sampled only on rising edges of the sample input.

The "windowing mode" is enabled by setting CR1[WE]. When set, the comparator output is sampled only when the WINDOW input signal is equal to one. This feature can be used to ignore the comparator output during time periods in which the input voltages are not valid. This is especially useful when implementing zero-crossing-detection for certain PWM applications.

The comparator filter and sampling features can be combined as shown in the following table. Individual modes are discussed below.

Table 32-29. Comparator Sample/Filter Controls

Mode #	CR1[EN]	CR1[WE]	CR1[SE]	CR0[FILTER_CNT]	FPR[FILT_PER]	Operation
1	0	X	X	X	X	Disabled Refer to the Disabled Mode (# 1) .
2A	1	0	0	0x00	X	Continuous Mode Refer to the Continuous Mode (#s 2A & 2B) .
2B	1	0	0	X	0x00	
3A	1	0	1	0x01	X	Sampled, Non-Filtered mode Refer to the Sampled, Non-Filtered Mode (#s 3A & 3B) .
3B	1	0	0	0x01	> 0x00	
4A	1	0	1	> 0x01	X	Sampled, Filtered mode Refer to the Sampled, Filtered Mode (#s 4A & 4B) .
4B	1	0	0	> 0x01	> 0x00	
5A	1	1	0	0x00	X	Windowed mode Comparator output is sampled on every rising bus clock edge when SAMPLE=1 to generate COUTA Refer to the Windowed Mode (#s 5A & 5B) .
5B	1	1	0	X	0x00	

Table continues on the next page...

Table 32-29. Comparator Sample/Filter Controls (continued)

Mode #	CR1[EN]	CR1[WE]	CR1[SE]	CR0[FILTER_CNT]	FPR[FILT_PER]	Operation
6	1	1	0	0x01	0x01 - 0xFF	Windowed/Resampled mode Comparator output is sampled on every rising bus clock edge when SAMPLE=1 to generate COUTA, which is then resampled on an interval determined by FILT_PER to generate COUT. Refer to the Windowed/Resampled Mode (# 6) .
7	1	1	0	> 0x01	0x01 - 0xFF	Windowed/Filtered mode Comparator output is sampled on every rising bus clock edge when SAMPLE=1 to generate COUTA, which is then resampled and filtered to generate COUT. Refer to the Windowed/Filtered Mode (#7) .
All other combinations of CR1[EN], CR1[WE], CR1[SE], CR0[FILTER_CNT], and FPR[FILT_PER] are illegal.						

For cases where a comparator is used to drive a fault input (for example, for a motor-control module such as FTM), it should generally be configured to operate in continuous mode, so that an external fault can immediately pass through the comparator to the target fault circuitry.

Note

Filtering and sampling settings should be changed only after setting CR1[SE]=0 and CR0[FILTER_CNT]=0x00. This has the effect of resetting the filter to a known state.

32.8.1.1 Disabled Mode (# 1)

In disabled mode, the analog comparator is non-functional and consumes no power. The output of the analog comparator block (CMPO) is zero in this mode.

32.8.1.2 Continuous Mode (#s 2A & 2B)

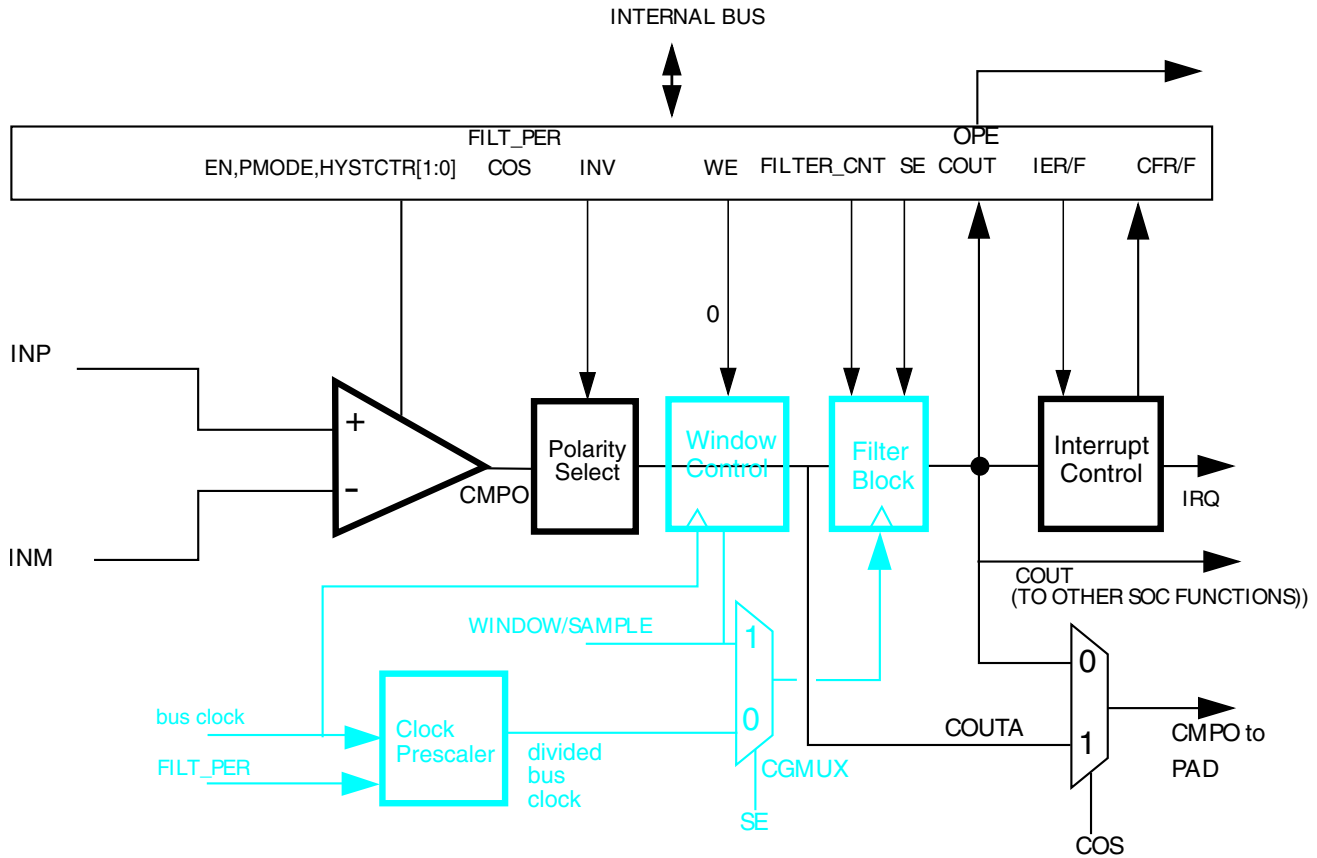

Figure 32-27. Comparator Operation in Continuous Mode

NOTE

Refer to the chip configuration section for the source of sample/window input.

The analog comparator block is powered and active. CMPO may be optionally inverted, but is not subject to external sampling or filtering. Both Window Control and Filter Blocks are completely bypassed. SCR[COUT] is updated continuously. The path from comparator inputs pins to output pin is operating in combinational (unclocked) mode. COUT and COUTA are identical.

For control configurations which result in disabling the Filter Block, refer to [Filter Block Bypass Logic](#) diagram.

32.8.1.3 Sampled, Non-Filtered Mode (#s 3A & 3B)

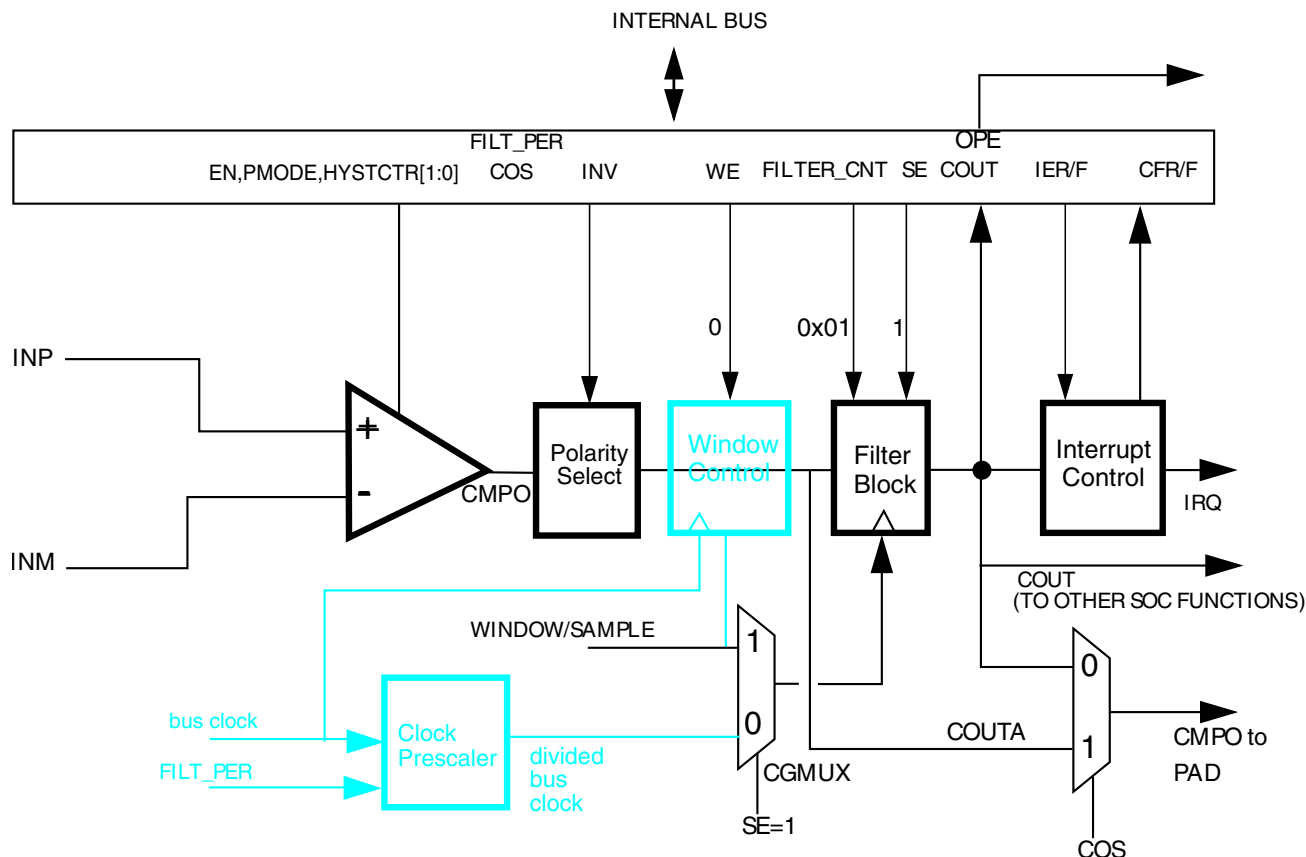

Figure 32-28. Sampled, Non-Filtered (# 3A): Sampling point externally driven

In Sampled, Non-Filtered mode, the analog comparator block is powered and active. The path from analog inputs to COUTA is combinational (unclocked). Windowing Control is completely bypassed. COUTA is sampled whenever a rising edge is detected on the Filter Block clock input.

The only difference in operation between Sampled, Non-Filtered (# 3A) and Sampled, Non-Filtered (# 3B) is in how the clock to the Filter Block is derived. In #3A, the clock to filter block is externally derived while in #3B, the clock to filter block is internally derived.

The comparator filter has no other function than sample/hold of the comparator output in this mode (# 3B).

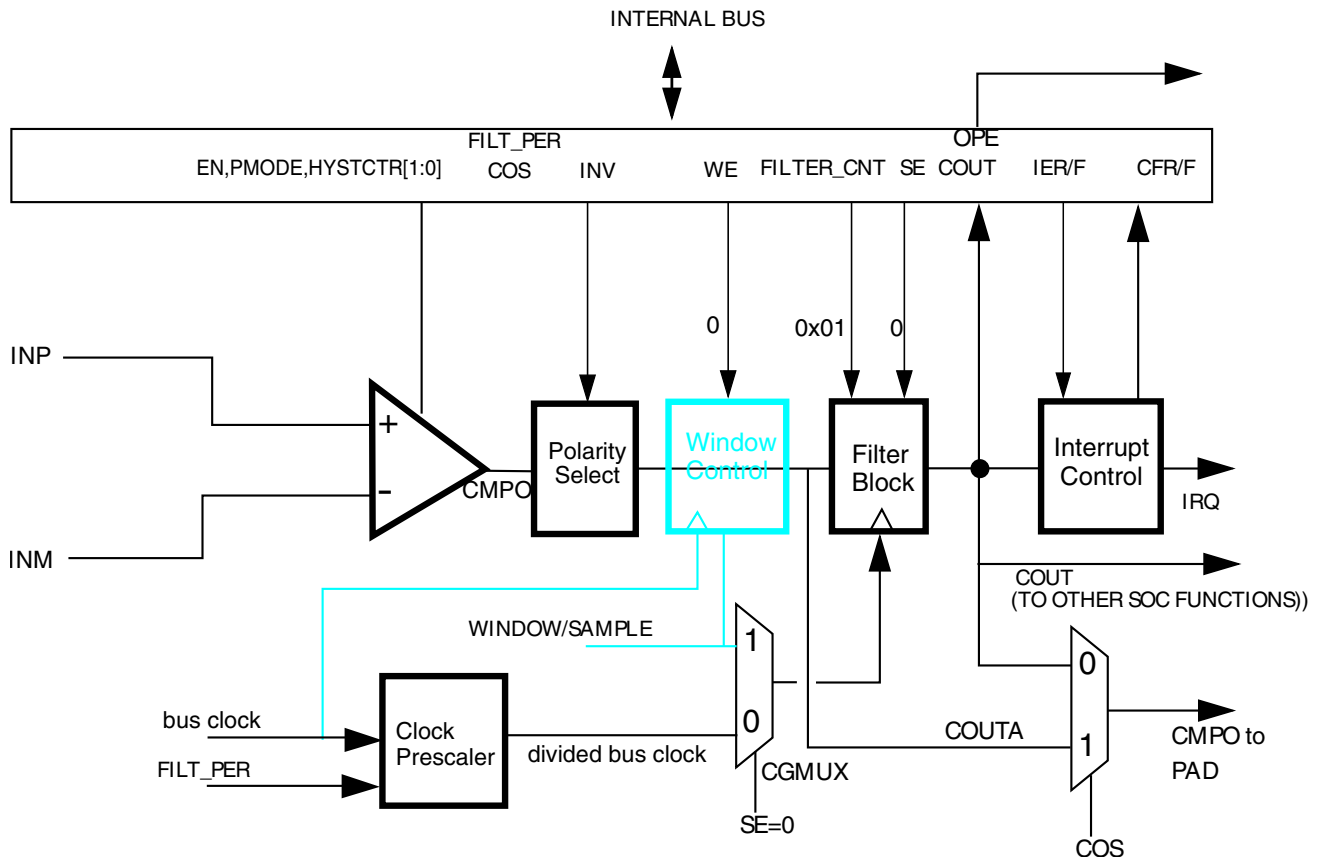

Figure 32-29. Sampled, Non-Filtered (# 3B): Sampling interval internally derived

32.8.1.4 Sampled, Filtered Mode (#s 4A & 4B)

In Sampled, Filtered mode, the analog comparator block is powered and active. The path from analog inputs to COUTA is combinational (unlocked). Windowing Control is completely bypassed. COUTA is sampled whenever a rising edge is detected on the Filter Block clock input.

The only difference in operation between Sampled, Non-Filtered (# 3A) and Sampled, Filtered (# 4A) is that CR0[FILTER_CNT] is now greater than 1, which activates filter operation.

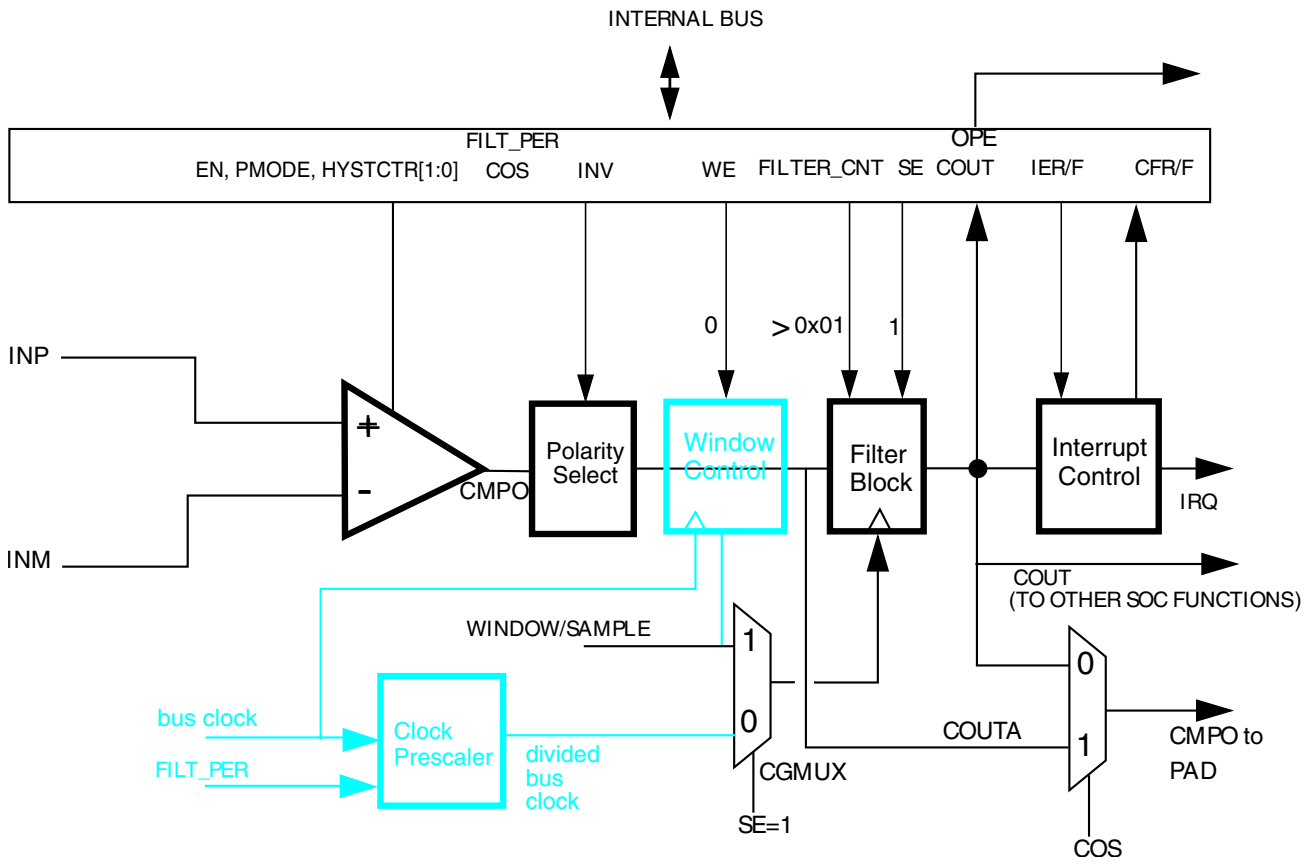

Figure 32-30. Sampled, Filtered (# 4A): Sampling point externally driven

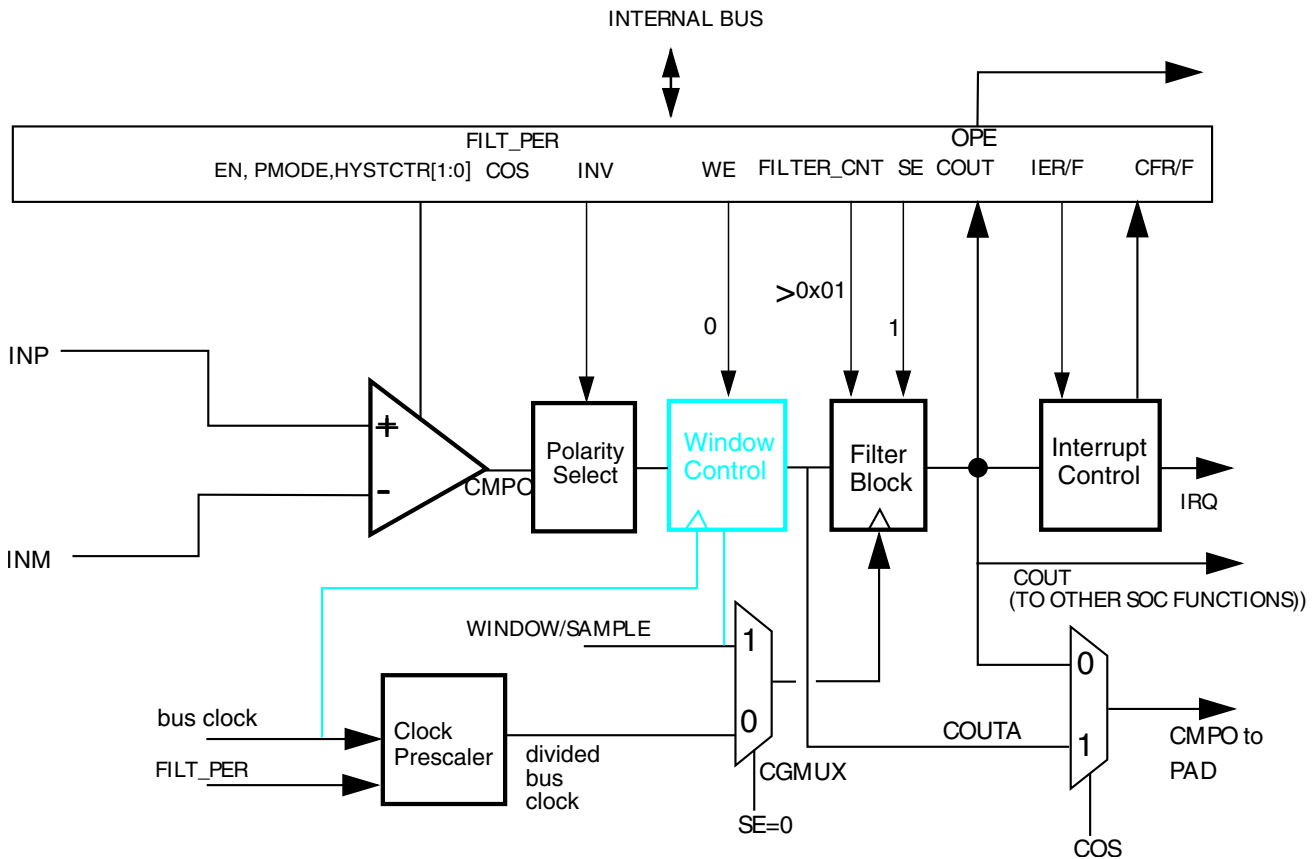

Figure 32-31. Sampled, Filtered (# 4B): Sampling point internally derived

The only difference in operation between Sampled, Non-Filtered (# 3B) and Sampled, Filtered (# 4B) is that CR0[FILTER_CNT] is now greater than 1, which activates filter operation.

32.8.1.5 Windowed Mode (#s 5A & 5B)

The following figure illustrates comparator operation in the windowed mode, ignoring latency of the analog comparator, polarity select and Window Control block. It also assumes that the Polarity Select is set to "non-inverting". Note that the analog comparator output is passed to COUTA only when the WINDOW signal is high.

In actual operation, COUTA may lag the analog inputs by up to one bus clock cycle plus the combinational path delay through the comparator and polarity select logic.

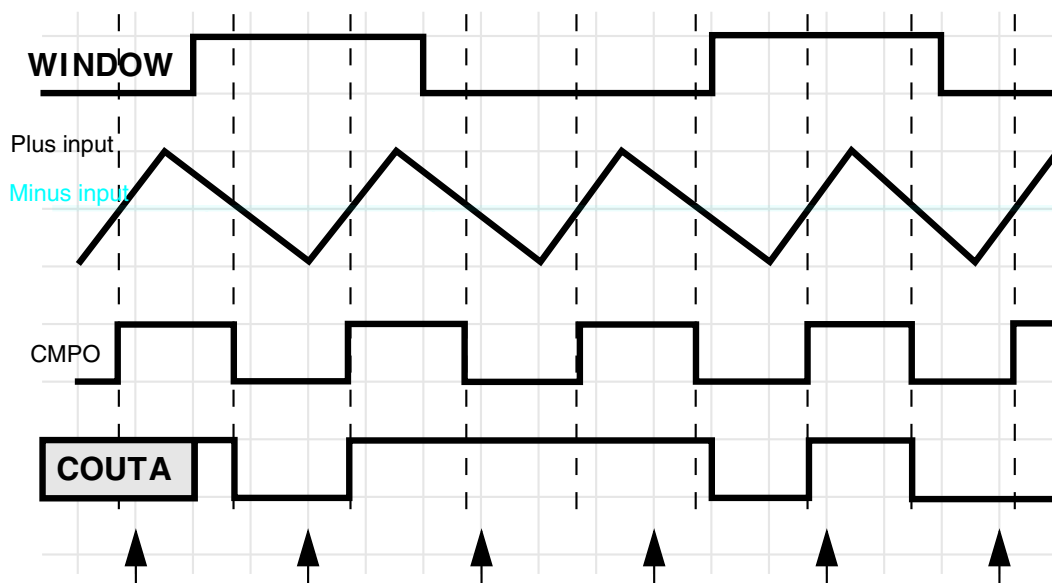

Figure 32-32. Windowed Mode Operation

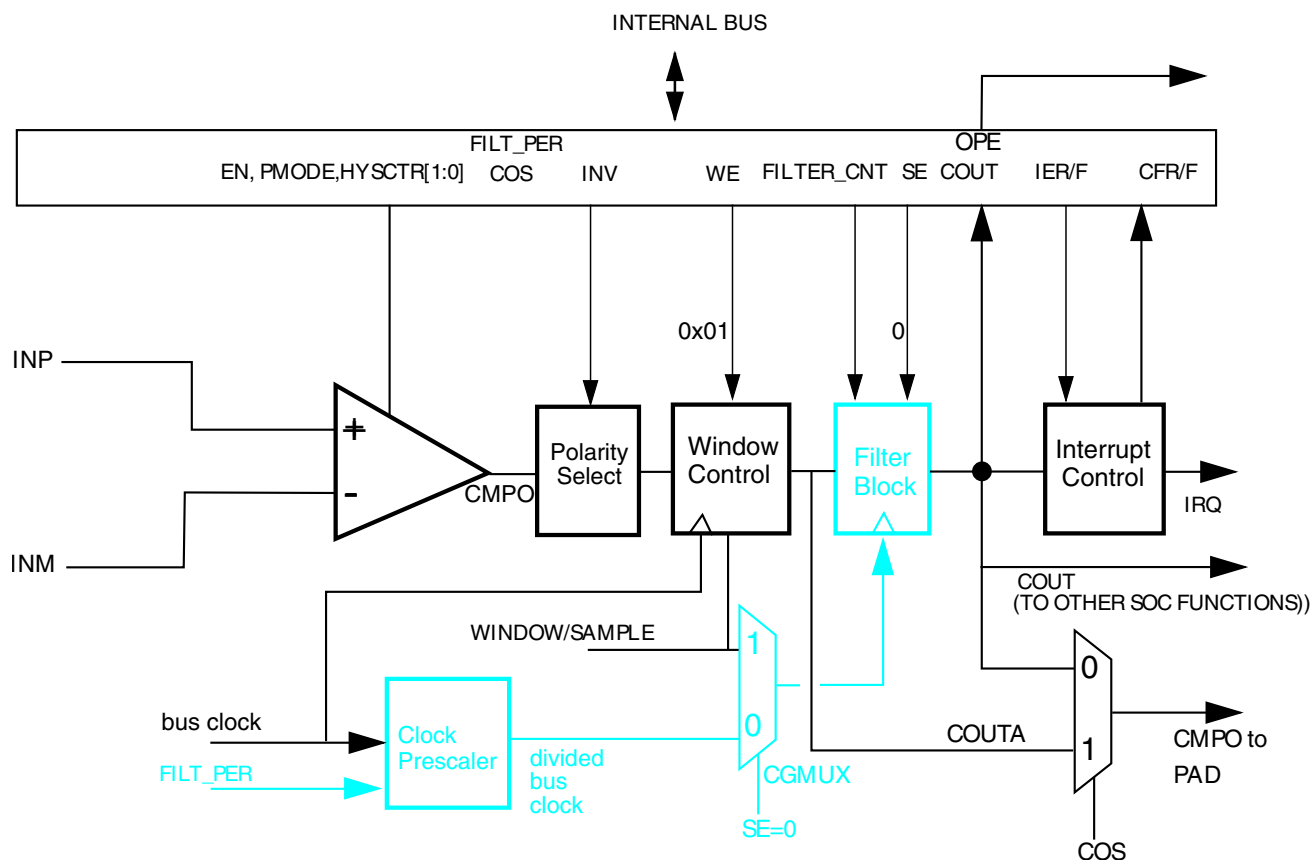

Figure 32-33. Windowed Mode

For control configurations which result in disabling the Filter Block, refer to [Filter Block Bypass Logic](#) diagram.

When any windowed mode is active, COUTA is clocked by the bus clock whenever WINDOW = 1. The last latched value is held when WINDOW = 0.

32.8.1.6 Windowed/Resampled Mode (# 6)

The following figure uses the same input stimulus shown in Figure 32-32, and adds resampling of COUTA to generate COUT. Samples are taken at the time points indicated by the arrows. Again, prop delays and latency is ignored for clarity's sake. This example was generated solely to demonstrate operation of the comparator in windowing / resampled mode, and does not reflect any specific application. Depending upon the sampling rate and window placement, COUT may not see zero-crossing events detected by the analog comparator. Sampling period and/or window placement must be carefully considered for a given application.

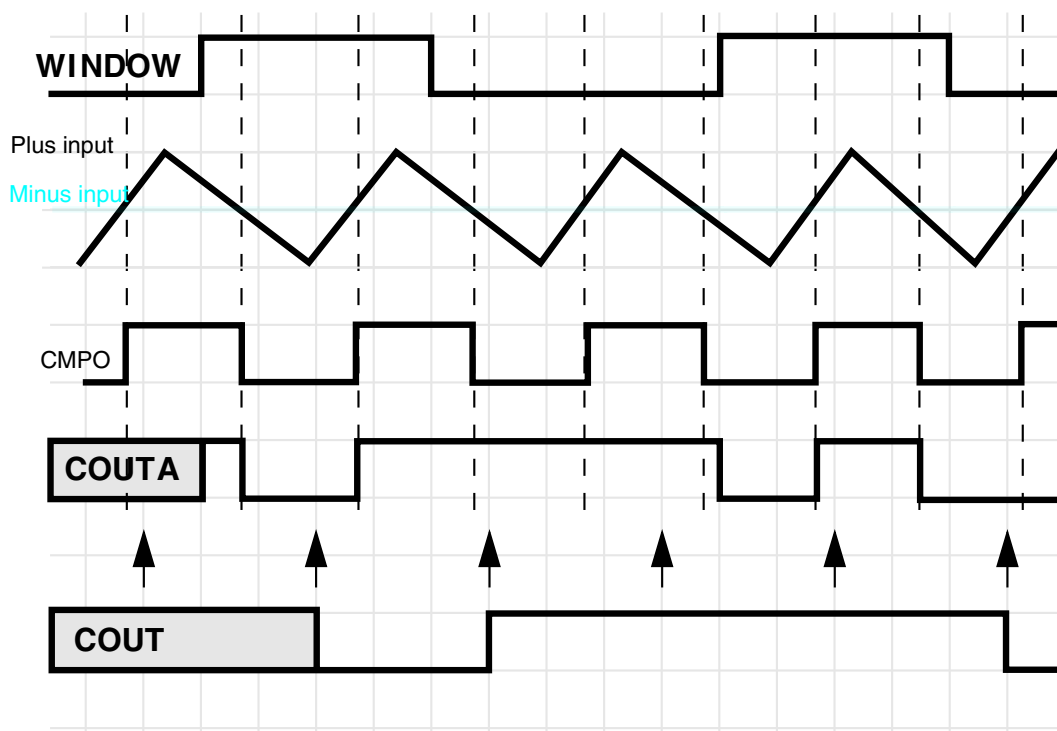

Figure 32-34. Windowed / Resampled Mode Operation

This mode of operation results in an unfiltered string of comparator samples where the interval between the samples is determined by FPR[FILT_PER] and the bus clock rate. Configuration for this mode is virtually identical to that for the Windowed/Filtered Mode shown in the next section. The only difference is that the value of CR0[FILTER_CNT] must be exactly one.

32.8.1.7 Windowed/Filtered Mode (#7)

This is the most complex mode of operation for the comparator block, as it utilizes both windowing and filtering features. It also has the highest latency of any of the modes. This can be approximated: up to 1 bus clock synchronization in the window function + $((CR0[FILTER_CNT] \times FPR[FILT_PER]) + 1) \times$ bus clock for the filter function.

When any windowed mode is active, COUTA is clocked by the bus clock whenever WINDOW = 1. The last latched value is held when WINDOW = 0.

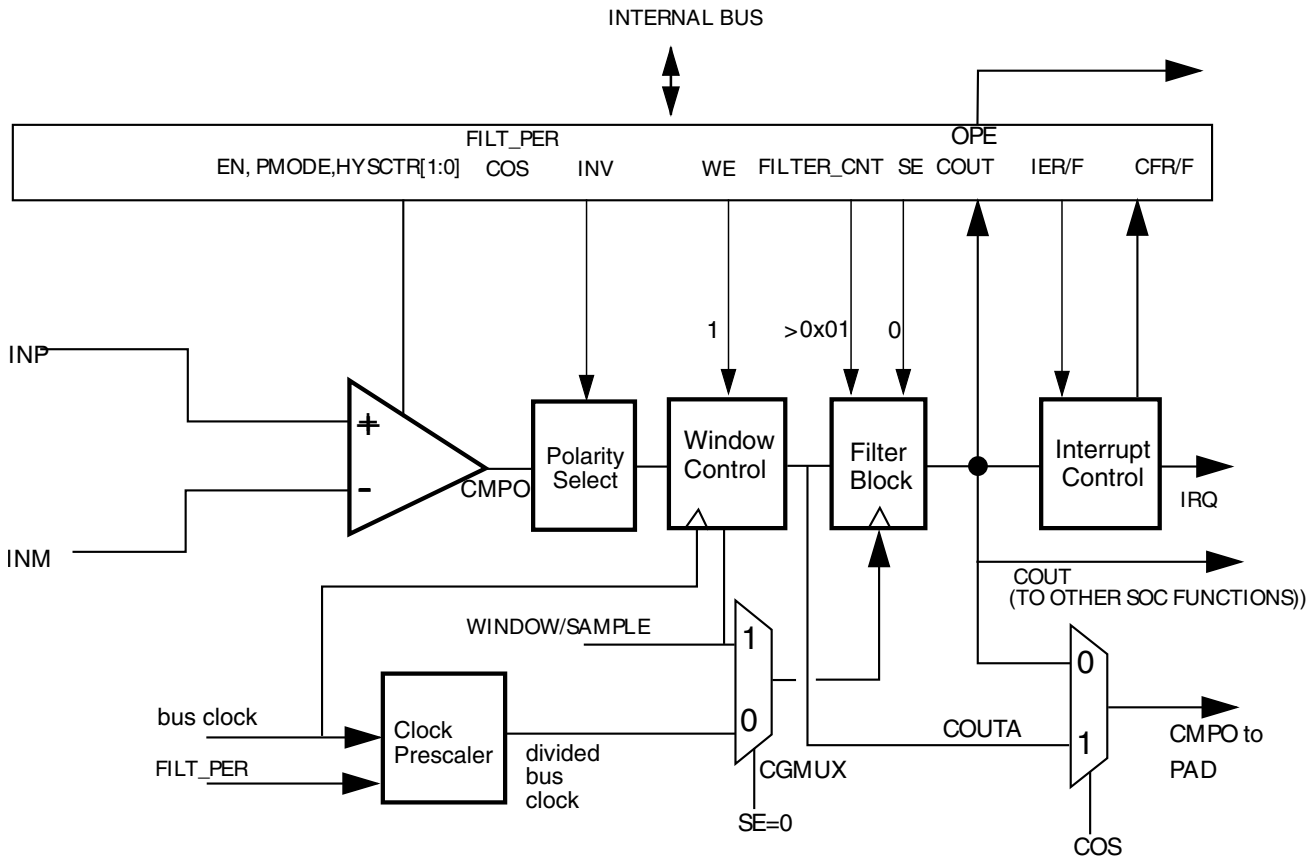

Figure 32-35. Windowed/Filtered Mode

32.8.2 Power Modes

32.8.2.1 Wait Mode Operation

During Wait and VLPW modes and if enabled, the CMP continues to operate normally. Also, if enabled, a CMP interrupt can wake the MCU.

32.8.2.2 Stop Mode Operation

Subject to platform-specific clock restrictions, the MCU is brought out of stop when a compare event occurs and the corresponding interrupt is enabled. Similarly, if CR1[OPE] is enabled, the comparator output operates as in the normal operating mode and comparator output is placed onto the external pin. In stop modes, the comparator can be operational in both high speed (HS) comparison mode (CR1[PMODE] = 1) and low speed (LS) comparison mode (CR1[PMODE] = 0), but it is recommended to use the low speed mode to minimize power consumption.

If stop is exited with a reset, all comparator registers are put into their reset state.

32.8.2.3 Low-Leakage Mode Operation

When the chip is in low-leakage modes, the CMP module is partially functional and is limited to low speed mode (regardless of the CR1[PMODE] bit's setting). Windowed, sampled, and filtered modes are not supported. The CMP output pin is latched and does not reflect the compare output state.

The positive- and negative-input voltage can be from external pins or the DAC output. The MCU can be brought out of the low-leakage mode if a compare event occurs and the CMP interrupt is enabled. After wakeup from low-leakage modes, the CMP module is in the reset state except for the SCR[CFF] and SCR[CFR] flags.

32.8.3 Startup and Operation

A typical startup sequence is as follows.

The time required to stabilize COUT will be the power-on delay of the comparators plus the largest propagation delay from a selected analog source through the analog comparator, windowing function and filter. Power on delay of the comparators are available from data sheets. The windowing function has a maximum of 1 bus clock period delay. Filter delay is specified in [Low Pass Filter](#).

During operation, the propagation delay of the selected data paths must always be considered. It can take many bus clock cycles for COUT and the CFR/CFF status bits to reflect an input change or a configuration change to one of the components involved in the data path.

When programmed for filtering modes, COUT will initially be equal to zero until sufficient clock cycles have elapsed to fill all stages of the filter. This occurs even if COUTA is at a logic one.

32.8.4 Low Pass Filter

The low-pass filter operates on the unfiltered and unsynchronized and optionally inverted comparator output COUTA and generates the filtered and synchronized output COUT. Both COUTA and COUT can be configured as module outputs and are used for different purposes within the system.

Synchronization and edge detection are always used to determine status register bit values. They also apply to COUT for all sampling and windowed modes. Filtering can be performed using an internal timebase defined by FPR[FILT_PER], or using an external SAMPLE input to determine sample time.

The need for digital filtering and the amount of filtering is dependent on user requirements. Filtering can become more useful in the absence of an external hysteresis circuit. Without external hysteresis, high frequency oscillations can be generated at COUTA when the selected INM and INP input voltages differ by less than the offset voltage of the differential comparator.

32.8.4.1 Enabling Filter Modes

Filter Modes are enabled by setting CR0[FILTER_CNT] greater than 0x01 and (setting FPR[FILT_PER] to a non-zero value OR setting CR1[SE]=1). If using the divided bus clock to drive the filter, it will take samples of COUTA every FPR[FILT_PER] bus clock cycles.

The filter output will be at logic zero when first initialized, and will subsequently change when CR0[FILTER_CNT] consecutive samples all agree that the output value has changed. Said another way, SCR[COUT] will be zero for some initial period, even when COUTA is at logic one.

Setting both CR1[SE] and FPR[FILT_PER] to 0 disables the filter and eliminates switching current associated with the filtering process.

Note

Always switch to this setting prior to making any changes in filter parameters. This resets the filter to a known state. Switching CR0[FILTER_CNT] on the fly without this intermediate step can result in unexpected behavior.

If CR1[SE]=1, the filter takes samples of COUTA on each positive transition of the sample input. The output state of the filter changes when CR0[FILTER_CNT] consecutive samples all agree that the output value has changed.

32.8.4.2 Latency Issues

The FPR[FILT_PER] value (or SAMPLE period) should be set such that the sampling period is just larger than the period of the expected noise. This way a noise spike will only corrupt one sample. The CR0[FILTER_CNT] value should be chosen to reduce the probability of noisy samples causing an incorrect transition to be recognized. The probability of an incorrect transition is defined as the probability of an incorrect sample raised to the CR0[FILTER_CNT] power.

The following table summarizes maximum latency values for the various modes of operation *in the absence of noise*. Filtering latency is restarted each time an actual output transition is masked by noise.

The values of FPR[FILT_PER] (or SAMPLE period) and CR0[FILTER_CNT] must also be traded off against the desire for minimal latency in recognizing actual comparator output transitions. The probability of detecting an actual output change within the nominal latency is the probability of a correct sample raised to the CR0[FILTER_CNT] power.

Table 32-30. Comparator Sample/Filter Maximum Latencies

Mode #	CR1[EN]	CR1[WE]	CR1[SE]	CR0[FILTER_CNT]	FPR[FILT_PER]	Operation	Maximum Latency ¹
1	0	X	X	X	X	Disabled	N/A
2A	1	0	0	0x00	X	Continuous Mode	T _{PD}
2B	1	0	0	X	0x00		
3A	1	0	1	0x01	X	Sampled, Non-Filtered mode	T _{PD} + T _{SAMPLE} + T _{per}
3B	1	0	0	0x01	> 0x00		T _{PD} + (FPR[FILT_PER] x T _{per}) + T _{per}
4A	1	0	1	> 0x01	X	Sampled, Filtered mode	T _{PD} + (CR0[FILTER_CNT] x T _{SAMPLE}) + T _{per}
4B	1	0	0	> 0x01	> 0x00		T _{PD} + (CR0[FILTER_CNT] x FPR[FILT_PER] x T _{per}) + T _{per}
5A	1	1	0	0x00	X	Windowed mode	T _{PD} + T _{per}
5B	1	1	0	X	0x00		T _{PD} + T _{per}
6	1	1	0	0x01	0x01 - 0xFF	Windowed / Resampled mode	T _{PD} + (FPR[FILT_PER] x T _{per}) + 2T _{per}

Table continues on the next page...

Table 32-30. Comparator Sample/Filter Maximum Latencies (continued)

Mode #	CR1[EN]	CR1[WE]	CR1[SE]	CR0[FILTER_CNT]	FPR[FILT_PER]	Operation	Maximum Latency ¹
7	1	1	0	> 0x01	0x01 - 0xFF	Windowed / Filtered mode	$T_{PD} + (CR0[FILTER_CNT] \times FPR[FILT_PER] \times T_{per}) + 2T_{per}$

1. T_{PD} represents the intrinsic delay of the analog component plus the polarity select logic. T_{SAMPLE} is the clock period of the external sample clock. T_{per} is the period of the bus clock.

32.9 CMP Interrupts

The CMP module is capable of generating an interrupt on either the rising or falling edge of the comparator output (or both). The interrupt request is asserted when both SCR[IER] bit and SCR[CFR] are set. It is also asserted when both SCR[IEF] bit and SCR[CFF] are set. The interrupt is de-asserted by clearing either SCR[IER] or SCR[CFR] for a rising edge interrupt, or SCR[IEF] and SCR[CFF] for a falling edge interrupt.

32.10 CMP DMA Support

Normally, the CMP generates a CPU interrupt if there is a change on the COUT. When DMA support (set SCR[DMAEN]) enables and the interrupt enables (set SCR[IER] or SCR[IEF] or both), the corresponding change on COUT forces a DMA transfer request rather than a CPU interrupt instead. When the DMA has completed the transfer, it sends a dma_done signal that de-asserts the dma_request and clears the flag to allow a subsequent change on comparator output to occur and force another DMA request.

32.11 Digital to Analog Converter Block Diagram

The following figure shows the block diagram of the DAC module. It contains a 64-tap resistor ladder network and a 64-to-1 multiplexer, which selects an output voltage from one of 64 distinct levels that outputs from DACO. It is controlled through DAC Control register (DACCR). Its supply reference source can be selected from two sources V_{in1} and V_{in2} . The module can be powered down (disabled) when it is not used. When in disable mode, DACO is connected to the analog ground.

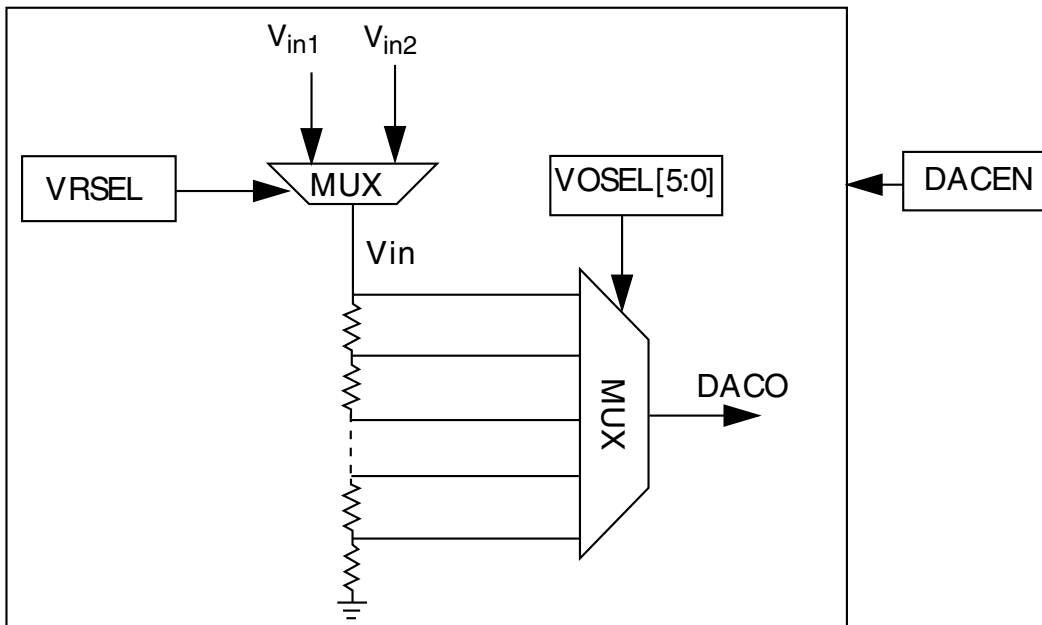

Figure 32-36. 6-bit DAC Block Diagram

32.12 DAC Functional Description

This section provides DAC functional description.

32.12.1 Voltage Reference Source Select

- V_{in1} should be used to connect to the primary voltage source as supply reference of 64 tap resistor ladder
- V_{in2} should be used to connect to alternate voltage source (or primary source if alternate voltage source is not available)

32.13 DAC Resets

This module has a single reset input, corresponding to the chip-wide peripheral reset.

32.14 DAC Clocks

This module has a single clock input, the bus clock.

32.15 DAC Interrupts

This module has no interrupts.

Chapter 33

12-bit Digital-to-Analog Converter (DAC)

33.1 Introduction

NOTE

For the chip-specific implementation details of this module's instances see the chip configuration chapter.

The 12-bit digital-to-analog converter (DAC) is a low power general purpose DAC. The output of this DAC can be placed on an external pin or set as one of the inputs to the analog comparator, Op-Amps, ADC, or other peripherals.

33.2 Features

The DAC module features include:

- On-chip programmable reference generator output (voltage output from $1/4096 V_{in}$ to V_{in} , step is $1/4096 V_{in}$)
- V_{in} can be selected from two reference sources
- Static operation in Normal Stop mode
- 16-word data buffer supported with configurable watermark and multiple operation modes
- DMA support

33.3 Block Diagram

The block diagram of the DAC module is as follows:

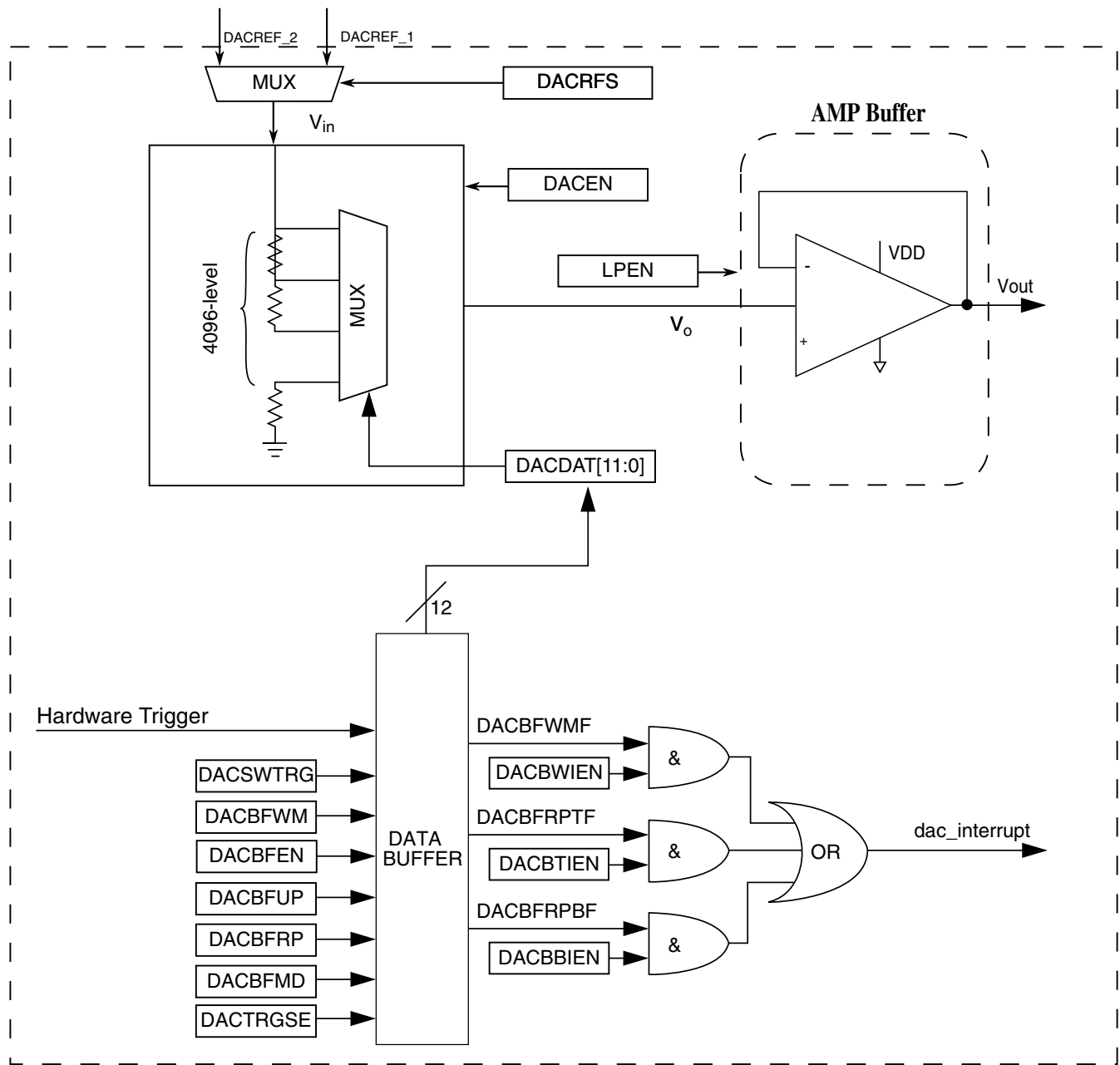

Figure 33-1. DAC Block Diagram

33.4 Memory Map/Register Definition

The DAC has registers to control analog comparator and programmable voltage divider to perform the digital-to-analog functions.

The address of a register is the sum of a base address and an address offset. The base address is defined at the chip level. The address offset is defined at the module level.

DAC memory map

Absolute address (hex)	Register name	Width (in bits)	Access	Reset value	Section/page
400C_C000	DAC Data Low Register (DAC0_DAT0L)	8	R/W	00h	33.4.1/756
400C_C001	DAC Data High Register (DAC0_DAT0H)	8	R/W	00h	33.4.2/757
400C_C002	DAC Data Low Register (DAC0_DAT1L)	8	R/W	00h	33.4.1/756
400C_C003	DAC Data High Register (DAC0_DAT1H)	8	R/W	00h	33.4.2/757
400C_C004	DAC Data Low Register (DAC0_DAT2L)	8	R/W	00h	33.4.1/756
400C_C005	DAC Data High Register (DAC0_DAT2H)	8	R/W	00h	33.4.2/757
400C_C006	DAC Data Low Register (DAC0_DAT3L)	8	R/W	00h	33.4.1/756
400C_C007	DAC Data High Register (DAC0_DAT3H)	8	R/W	00h	33.4.2/757
400C_C008	DAC Data Low Register (DAC0_DAT4L)	8	R/W	00h	33.4.1/756
400C_C009	DAC Data High Register (DAC0_DAT4H)	8	R/W	00h	33.4.2/757
400C_C00A	DAC Data Low Register (DAC0_DAT5L)	8	R/W	00h	33.4.1/756
400C_C00B	DAC Data High Register (DAC0_DAT5H)	8	R/W	00h	33.4.2/757
400C_C00C	DAC Data Low Register (DAC0_DAT6L)	8	R/W	00h	33.4.1/756
400C_C00D	DAC Data High Register (DAC0_DAT6H)	8	R/W	00h	33.4.2/757
400C_C00E	DAC Data Low Register (DAC0_DAT7L)	8	R/W	00h	33.4.1/756
400C_C00F	DAC Data High Register (DAC0_DAT7H)	8	R/W	00h	33.4.2/757
400C_C010	DAC Data Low Register (DAC0_DAT8L)	8	R/W	00h	33.4.1/756
400C_C011	DAC Data High Register (DAC0_DAT8H)	8	R/W	00h	33.4.2/757
400C_C012	DAC Data Low Register (DAC0_DAT9L)	8	R/W	00h	33.4.1/756
400C_C013	DAC Data High Register (DAC0_DAT9H)	8	R/W	00h	33.4.2/757

Table continues on the next page...

DAC memory map (continued)

Absolute address (hex)	Register name	Width (in bits)	Access	Reset value	Section/page
400C_C014	DAC Data Low Register (DAC0_DAT10L)	8	R/W	00h	33.4.1/756
400C_C015	DAC Data High Register (DAC0_DAT10H)	8	R/W	00h	33.4.2/757
400C_C016	DAC Data Low Register (DAC0_DAT11L)	8	R/W	00h	33.4.1/756
400C_C017	DAC Data High Register (DAC0_DAT11H)	8	R/W	00h	33.4.2/757
400C_C018	DAC Data Low Register (DAC0_DAT12L)	8	R/W	00h	33.4.1/756
400C_C019	DAC Data High Register (DAC0_DAT12H)	8	R/W	00h	33.4.2/757
400C_C01A	DAC Data Low Register (DAC0_DAT13L)	8	R/W	00h	33.4.1/756
400C_C01B	DAC Data High Register (DAC0_DAT13H)	8	R/W	00h	33.4.2/757
400C_C01C	DAC Data Low Register (DAC0_DAT14L)	8	R/W	00h	33.4.1/756
400C_C01D	DAC Data High Register (DAC0_DAT14H)	8	R/W	00h	33.4.2/757
400C_C01E	DAC Data Low Register (DAC0_DAT15L)	8	R/W	00h	33.4.1/756
400C_C01F	DAC Data High Register (DAC0_DAT15H)	8	R/W	00h	33.4.2/757
400C_C020	DAC Status Register (DAC0_SR)	8	R	02h	33.4.3/757
400C_C021	DAC Control Register (DAC0_C0)	8	R/W	00h	33.4.4/758
400C_C022	DAC Control Register 1 (DAC0_C1)	8	R/W	00h	33.4.5/759
400C_C023	DAC Control Register 2 (DAC0_C2)	8	R/W	0Fh	33.4.6/760

33.4.1 DAC Data Low Register (DACx_DATL)

Addresses: 400C_C000h base + 0h offset + (2d × n), where n = 0d to 15d

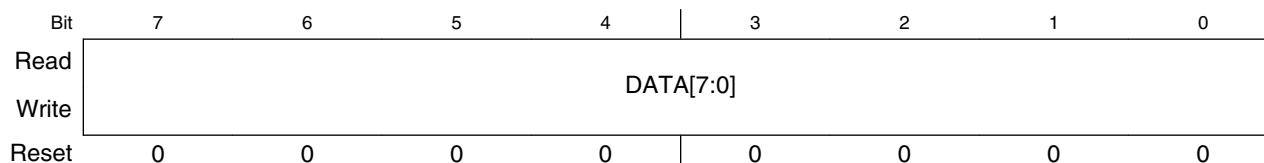

DACx_DATnL field descriptions

Field	Description
7-0 DATA[7:0]	When the DAC Buffer is not enabled, DATA[11:0] controls the output voltage based on the following formula. $V_{out} = V_{in} * (1 + DACDAT0[11:0])/4096$ When the DAC Buffer is enabled, DATA is mapped to the 16-word buffer.

33.4.2 DAC Data High Register (DACx_DATH)

Addresses: 400C_C000h base + 1h offset + (2d × n), where n = 0d to 15d

Bit	7	6	5	4	3	2	1	0
Read	0				DATA[11:8]			
Write	[Shaded]				DATA[11:8]			
Reset	0	0	0	0	0	0	0	0

DACx_DATnH field descriptions

Field	Description
7-4 Reserved	This read-only field is reserved and always has the value zero.
3-0 DATA[11:8]	When the DAC Buffer is not enabled, DATA[11:0] controls the output voltage based on the following formula. $V_{out} = V_{in} * (1 + DACDAT0[11:0])/4096$ When the DAC Buffer is enabled, DATA[11:0] is mapped to the 16-word buffer.

33.4.3 DAC Status Register (DACx_SR)

If DMA is enabled, the flags can be cleared automatically by DMA when the DMA request is done. Write zero to a bit to clear it. Writing one has no effect. After reset DACBFRPTF is set and can be cleared by software, if needed. The flags are set only when the data buffer status is changed.

Addresses: DAC0_SR is 400C_C000h base + 20h offset = 400C_C020h

Bit	7	6	5	4	3	2	1	0
Read	0					DACBFWMF	DACBFRPTF	DACBFRPBF
Write	[Shaded]					DACBFWMF	DACBFRPTF	DACBFRPBF
Reset	0	0	0	0	0	0	1	0

DACx_SR field descriptions

Field	Description
7-3 Reserved	This read-only field is reserved and always has the value zero. Reserved

Table continues on the next page...

DACx_SR field descriptions (continued)

Field	Description
2 DACBFWMF	DAC buffer watermark flag 0 The DAC buffer read pointer has not reached the watermark level. 1 The DAC buffer read pointer has reached the watermark level.
1 DACBFRPTF	DAC buffer read pointer top position flag 0 The DAC buffer read pointer is not zero. 1 The DAC buffer read pointer is zero.
0 DACBFRPBF	DAC buffer read pointer bottom position flag 0 The DAC buffer read pointer is not equal to the DACBFUP. 1 The DAC buffer read pointer is equal to the DACBFUP.

33.4.4 DAC Control Register (DACx_C0)

Addresses: DAC0_C0 is 400C_C000h base + 21h offset = 400C_C021h

Bit	7	6	5	4	3	2	1	0
Read	DACEN	DACRFS	DACTRGSEL	0	LPEN	DACBWIEN	DACBTIEN	DACBBIEN
Write				DACSWTRG				
Reset	0	0	0	0	0	0	0	0

DACx_C0 field descriptions

Field	Description
7 DACEN	DAC enable The DACEN bit starts the Programmable Reference Generator operation. 0 The DAC system is disabled. 1 The DAC system is enabled.
6 DACRFS	DAC Reference Select 0 The DAC selects DACREF_1 as the reference voltage. 1 The DAC selects DACREF_2 as the reference voltage.
5 DACTRGSEL	DAC trigger select 0 The DAC hardware trigger is selected. 1 The DAC software trigger is selected.
4 DACSCTR	DAC software trigger Active high. This is a write-only bit, read it always be 0. If DAC software trigger is selected and buffer enabled, write 1 to this bit will advance the buffer read pointer once. 0 The DAC soft trigger is not valid. 1 The DAC soft trigger is valid.

Table continues on the next page...

DACx_C0 field descriptions (continued)

Field	Description
3 LPEN	DAC low power control Refer to the device data sheet's 12-bit DAC electrical characteristics for details on the impact of the modes below. 0 high power mode. 1 low power mode.
2 DACBWIEN	DAC buffer watermark interrupt enable 0 The DAC buffer watermark interrupt is disabled. 1 The DAC buffer watermark interrupt is enabled.
1 DACBTIEN	DAC buffer read pointer top flag interrupt enable 0 The DAC buffer read pointer top flag interrupt is disabled. 1 The DAC buffer read pointer top flag interrupt is enabled.
0 DACBBIEN	DAC buffer read pointer bottom flag interrupt enable 0 The DAC buffer read pointer bottom flag interrupt is disabled. 1 The DAC buffer read pointer bottom flag interrupt is enabled.

33.4.5 DAC Control Register 1 (DACx_C1)

Addresses: DAC0_C1 is 400C_C000h base + 22h offset = 400C_C022h

Bit	7	6	5	4	3	2	1	0
Read	DMAEN	0			DACBFWM	DACBFMD		DACBFEN
Write								
Reset	0	0	0	0	0	0	0	0

DACx_C1 field descriptions

Field	Description
7 DMAEN	DMA enable select 0 DMA disabled. 1 DMA enabled. When DMA enabled, DMA request will be generated by original interrupts. And interrupts will not be presented on this module at the same time.
6–5 Reserved	This read-only field is reserved and always has the value zero.
4–3 DACBFWM	DAC buffer watermark select This bitfield controls when the DAC buffer watermark flag will be set. When the DAC buffer read pointer reaches the word defined by this bitfield, from 1 to 4 words away from the upper limit (DACBUP), the DAC buffer watermark flag will be set. This allows user configuration of the watermark interrupt. 00 1 word

Table continues on the next page...

DACx_C1 field descriptions (continued)

Field	Description
	01 2 words 10 3 words 11 4 words
2–1 DACBFMD	DAC buffer work mode select 00 Normal Mode 01 Swing Mode 10 One-Time Scan Mode 11 Reserved
0 DACBFEN	DAC buffer enable 0 Buffer read pointer disabled. The converted data is always the first word of the buffer. 1 Buffer read pointer enabled. The converted data is the word that the read pointer points to. It means converted data can be from any word of the buffer.

33.4.6 DAC Control Register 2 (DACx_C2)

Addresses: DAC0_C2 is 400C_C000h base + 23h offset = 400C_C023h

Bit	7	6	5	4	3	2	1	0
Read	DACBFRP				DACBFUP			
Write								
Reset	0	0	0	0	1	1	1	1

DACx_C2 field descriptions

Field	Description
7–4 DACBFRP	DAC buffer read pointer These 4 bits keep the current value of the buffer read pointer.
3–0 DACBFUP	DAC buffer upper limit These 4 bits select the buffer's upper limit. The buffer read pointer cannot exceed it.

33.5 Functional Description

The 12-bit DAC module can select one of the two reference inputs — DACREF_1 and DACREF_2 as the DAC reference voltage (V_{in}) by DACRFS bit of C0 register. Refer to the module introduction for information on the source for DACREF_1 and DACREF_2. When the DAC is enabled, it converts the data in DACDAT0[11:0] or the data from the DAC data buffer to a stepped analog output voltage. The output voltage range is from $V_{in}/4096$ to V_{in} , and the step is $V_{in}/4096$.

33.5.1 DAC Data Buffer Operation

When the DAC is enabled and the buffer is not enabled, the DAC module always converts the data in DAT0 to analog output voltage.

When both the DAC and the buffer are enabled, the DAC converts the data in the data buffer to analog output voltage. The data buffer read pointer advances to the next word in the event the hardware trigger or the software trigger occurs. Refer to the PDB Module Interconnections section in Chip Configuration chapter for the hardware trigger connection.

The data buffer can be configured to operate in normal mode, swing mode or one-time scan mode. When the buffer operation is switched from one mode to another, the read pointer does not change. The read pointer can be set to any value between "0" and DACBFUP by writing DACBFRP in C2 register.

33.5.1.1 DAC Data Buffer Interrupts

There are several interrupts and associated flags that can be configured for the DAC buffer. The DAC read pointer bottom position flag is set when the DAC buffer read pointer reaches the DAC buffer upper limit. ($DACBFRP = DACBFUP$). The DAC read pointer top position flag is set when the DAC read pointer is equal to the start position, 0. Finally, the DAC buffer watermark flag is set when the DAC buffer read pointer has reached the position defined by the DAC watermark select bit field. The DAC watermark select (DACBFWM) can be used to generate an interrupt when the DAC buffer Read pointer is between 1 to 4 words from the DAC buffer upper limit.

33.5.1.2 Buffer Normal Mode

This is the default mode. The buffer works as a circular buffer. The read pointer increases by one, every time when the trigger occurs. When the read pointer reaches the upper limit, it goes to the zero directly in the next trigger event.

33.5.1.3 Buffer Swing Mode

This mode is similar to the normal mode. But when the read pointer reaches the upper limit, it does not go to the zero. It will descend by one in the next trigger events until zero is reached.

33.5.1.4 Buffer One-time Scan Mode

The read pointer increases by one every time when the trigger occurs. When it reaches the upper limit, it stops at there. If read pointer is reset to the address other than the upper limit, it will increase to the upper address and stop at there again.

Note

If the software set the read pointer to the upper limit, the read pointer will not advance in this mode.

33.5.2 DMA Operation

When DMA is enabled, interrupt requests are not generated. DMA requests are generated instead. DMA done signal clears the DMA request.

The status register flags are still set and are cleared automatically when the DMA completes.

33.5.3 Resets

During reset the DAC is configured in the default mode. DAC is disabled.

33.5.4 Low Power Mode Operation

This section describes the wait mode and the stop mode operation of the DAC module.

33.5.4.1 Wait Mode Operation

In wait mode, the DAC will operate normally if enabled.

33.5.4.2 Stop Mode Operation

The DAC continues to operate in Normal Stop mode if enabled, the output voltage will hold the value before stop.

In Low Power Stop modes, the DAC is fully shut-down.

NOTE

The assignment of module modes to core modes is chip-specific. For module-to-core mode assignments, see the chapter that describes how modules are configured.



Chapter 34

Voltage Reference (VREFV1)

34.1 Introduction

NOTE

For the chip-specific implementation details of this module's instances see the chip configuration chapter.

The VREFV1 Voltage Reference is intended to supply an accurate voltage output that can be trimmed in 0.5 mV steps. The VREFV1 can be used in applications to provide a reference voltage to external devices or used internally as a reference to analog peripherals such as the ADC, DAC, or CMP. The voltage reference has two operating modes that provide different levels of supply rejection and power consumption.

The following figure is a block diagram of the Voltage Reference.

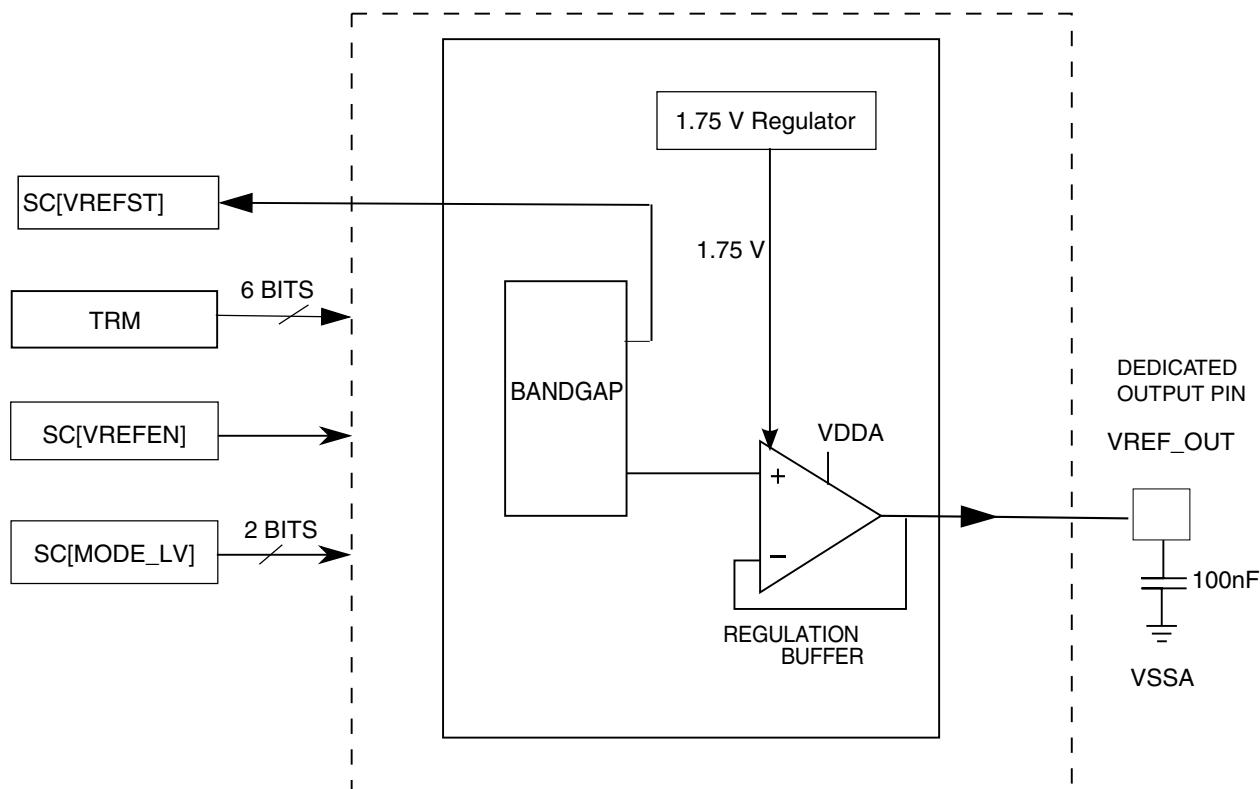

Figure 34-1. Voltage reference block diagram

34.1.1 Overview

The Voltage Reference provides a buffered reference voltage with high output current for use as an external reference. In addition, the buffered reference is available internally for use with on chip peripherals such as ADCs and DACs. Refer to the chip configuration chapter for a description of these options. The reference voltage is output on a dedicated output pin when the VREF is enabled. The Voltage Reference output can be trimmed with a resolution of 0.5mV by means of the TRM register TRIM[5:0] bitfield.

34.1.2 Features

The Voltage Reference has the following features:

- Programmable trim register with 0.5 mV steps, automatically loaded with factory trimmed value upon reset
- Programmable buffer mode selection:
 - Off

- Bandgap enabled/standby (output buffer disabled)
- Tight-regulation buffer mode (output buffer enabled)
- 1.2 V output at room temperature
- Dedicated output pin, VREF_OUT
- Load regulation in tight-regulation mode

34.1.3 Modes of Operation

The Voltage Reference continues normal operation in Run, Wait, and Stop modes. The Voltage Reference can also run in Very Low Power Run (VLPR), Very Low Power Wait (VLPW) and Very Low Power Stop (VLPS). The VREF regulator is not available in any Very Low Power modes and must be disabled (SC[REGEN]=0) before entering these modes. Note however that the accuracy of the output voltage will be reduced (by as much as several mVs) when the VREF regulator is not used.

NOTE

The assignment of module modes to core modes is chip-specific. For module-to-core mode assignments, see the chapter that describes how modules are configured.

34.1.4 VREF Signal Descriptions

The following table shows the Voltage Reference signals properties.

Table 34-1. VREF Signal Descriptions

Signal	Description	I/O
VREF_OUT	Internally-generated Voltage Reference output	O

NOTE

- In Disable mode, the status of the VREF_OUT signal is high-impedence.

34.2 Memory Map and Register Definition

VREF memory map

Absolute address (hex)	Register name	Width (in bits)	Access	Reset value	Section/page
4007_4000	VREF Trim Register (VREF_TRM)	8	R/W	Undefined	34.2.1/ 768
4007_4001	VREF Status and Control Register (VREF_SC)	8	R/W	00h	34.2.2/ 769

34.2.1 VREF Trim Register (VREF_TRM)

This register contains bits that contain the trim data for the Voltage Reference.

Address: VREF_TRM is 4007_4000h base + 0h offset = 4007_4000h

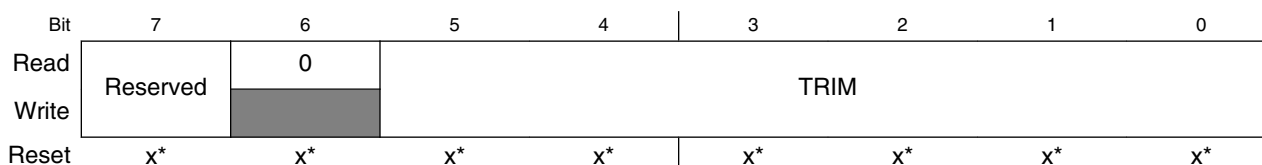

* Notes:

- x = Undefined at reset.

VREF_TRM field descriptions

Field	Description
7 Reserved	This field is reserved. Upon reset this value is loaded with a factory trim value. This bit must always be written with the original reset value.
6 Reserved	This read-only field is reserved and always has the value zero.
5-0 TRIM	Trim bits Upon reset this value is loaded with a factory trim value. These bits change the resulting VREF by approximately ± 0.5 mV for each step. NOTE: Min = minimum and max = maximum voltage reference output. For minimum and maximum voltage reference output values, refer to the Data Sheet for this chip. 000000 Min 111111 Max

34.2.2 VREF Status and Control Register (VREF_SC)

This register contains the control bits used to enable the internal voltage reference and to select the VREF mode to be used.

Address: VREF_SC is 4007_4000h base + 1h offset = 4007_4001h

Bit	7	6	5	4	3	2	1	0
Read	VREFEN	REGEN	Reserved	0	0	VREFST	MODE_LV	
Write								
Reset	0	0	0	0	0	0	0	0

VREF_SC field descriptions

Field	Description
7 VREFEN	Internal Voltage Reference enable This bit is used to enable the bandgap reference within the Voltage Reference module. NOTE: After the VREF is enabled, turning off the clock to the VREF module via the corresponding clock gate register will not disable the VREF. VREF must be disabled via this VREFEN bit. 0 The module is disabled. 1 The module is enabled.
6 REGEN	Regulator enable This bit is used to enable the internal 1.75 V VREF regulator to produce a constant internal voltage supply in order to reduce the sensitivity to external supply noise and variation. The VREF regulator must not be enabled when entering VLPR, VLPW or VLPS modes. 0 Internal 1.75 V regulator is disabled. 1 Internal 1.75 V regulator is enabled.
5 Reserved	This field is reserved. This bit must always be written to zero.
4 Reserved	This read-only field is reserved and always has the value zero.
3 Reserved	This read-only field is reserved and always has the value zero.
2 VREFST	Internal Voltage Reference has settled This bit indicates that the bandgap reference within the Voltage Reference module has completed its startup and stabilization. 0 The bandgap is disabled or not ready. 1 The bandgap is ready.
1-0 MODE_LV	Buffer Mode selection These bits select the buffer modes for the Voltage Reference module. 00 Bandgap on only, for stabilization and startup 01 Reserved

Table continues on the next page...

VREF_SC field descriptions (continued)

Field	Description
10	Tight-regulation buffer enabled
11	Reserved

34.3 Functional Description

The Voltage Reference is a bandgap buffer system. Unity gain amplifiers are used.

The VREF_OUT signal is available as an internal reference when it is enabled. A 100 nF capacitor must be connected between VREF_OUT and VSSA.

The following table shows all possible function configurations of the Voltage Reference.

Table 34-5. Voltage Reference function configurations

SC[VREFEN]	SC[MODE_LV]	Configuration	Functionality
0	X	Voltage Reference disabled	Off
1	00	Voltage Reference enabled, only the VREF bandgap is on	Startup and standby
1	01	Reserved	Reserved
1	10	Voltage Reference enabled, VREF bandgap and tight-regulation buffer on	VREF_OUT available for internal and external use. 100 nF capacitor is required.
1	11	Reserved	Reserved

34.3.1 Voltage Reference Disabled, SC[VREFEN] = 0

When SC[VREFEN] = 0, the Voltage Reference is disabled, all bandgap and buffers are disabled. The Voltage Reference is in off mode.

34.3.2 Voltage Reference Enabled, SC[VREFEN] = 1

When SC[VREFEN] = 1, the Voltage Reference is enabled, and different modes can be set by the SC[MODE_LV] bits.

34.3.2.1 SC[MODE_LV]=00

The internal bandgap is enabled to generate an accurate 1.2 V output that can be trimmed with the TRM register's TRIM[5:0] bitfield. The bandgap requires some time for startup and stabilization. SC[VREFST] can be monitored to determine if the stabilization and startup is complete.

The output buffer is disabled in this mode, and there is no buffered voltage output. The Voltage Reference is in standby mode. If this mode is first selected and the tight regulation buffer mode is subsequently enabled, there will be a delay before the buffer output is settled at the final value. This is the buffer start up delay (T_{st}) and the value is specified in the appropriate device data sheet.

34.3.2.2 SC[MODE_LV] = 01

Reserved

34.3.2.3 SC[MODE_LV] = 10

The tight regulation buffer is enabled to generate a buffered 1.2 V voltage to VREF_OUT. If this mode is entered from the standby mode (SC[MODE_LV] = 00, SC[VREFEN] = 1) there will be a delay before the buffer output is settled at the final value. This is the buffer start up delay (T_{st}) and the value is specified in the appropriate device data sheet. If this mode is entered when the VREF module is enabled then you must wait the longer of T_{st} or until SC[VREFST] = 1.

34.3.2.4 SC[MODE_LV] = 11

Reserved

34.4 Initialization/Application Information

The Voltage Reference requires some time for startup and stabilization. After SC[VREFEN] = 1, SC[VREFST] can be monitored to determine if the stabilization and startup of the VREF bandgap is complete.

When the Voltage Reference is already enabled and stabilized, changing SC[MODE_LV] will not clear SC[VREFST] but there will be some startup time before the output voltage at the VREF_OUT pin has settled. This is the buffer start up delay (T_{stup}) and the value is specified in the appropriate device data sheet. Also, there will be some settling time when a step change of the load current is applied to the VREF_OUT pin.

When the 1.75V VREF regulator is disabled, the VREF_OUT voltage will be more sensitive to supply voltage variation. It is recommended to use this regulator to achieve optimum VREF_OUT performance.

Chapter 35

Programmable Delay Block (PDB)

35.1 Introduction

NOTE

For the chip-specific implementation details of this module's instances see the chip configuration chapter.

The programmable delay block (PDB) provides controllable delays from either an internal or an external trigger, or a programmable interval tick, to the hardware trigger inputs of ADCs and/or generates the interval triggers to DACs, so that the precise timing between ADC conversions and/or DAC updates can be achieved. The PDB can optionally provide pulse outputs (Pulse-Out's) that are used as the sample window in the CMP block.

35.1.1 Features

- Up to 15 trigger input sources and software trigger source
- Up to eight configurable PDB channels for ADC hardware trigger
 - One PDB channel is associated with one ADC.
 - One trigger output for ADC hardware trigger and up to eight pre-trigger outputs for ADC trigger select per PDB channel
 - Trigger outputs can be enabled or disabled independently.
 - One 16-bit delay register per pre-trigger output
 - Optional bypass of the delay registers of the pre-trigger outputs
 - Operation in One-Shot or Continuous modes

- Optional back-to-back mode operation, which enables the ADC conversions complete to trigger the next PDB channel
- One programmable delay interrupt
- One sequence error interrupt
- One channel flag and one sequence error flag per pre-trigger
- DMA support
- Up to eight DAC interval triggers
 - One interval trigger output per DAC
 - One 16-bit delay interval register per DAC trigger output
 - Optional bypass the delay interval trigger registers
 - Optional external triggers
- Up to eight pulse outputs (pulse-out's)
 - Pulse-out's can be enabled or disabled independently.
 - Programmable pulse width

NOTE

The number of PDB input and output triggers are chip-specific. Refer to the Chip Configuration information for details.

35.1.2 Implementation

In this chapter, the following letters refers to the number of output triggers.

- N — Total available number of PDB channels.
- n — PDB channel number, valid from 0 to $N-1$.
- M — Total available pre-trigger per PDB channel.
- m — Pre-trigger number, valid from 0 to $M-1$.
- X — Total number of DAC interval triggers.
- x — DAC interval trigger output number, valid from 0 to $X-1$.

- Y — Total number of Pulse-Out's.
- y — Pulse-Out number, valid value is 0 to $Y-1$.

NOTE

The number of module output triggers to core are chip-specific. For module to core output triggers implementation, refer to the Chip Configuration information.

35.1.3 Back-to-back Acknowledgement Connections

PDB back-to-back operation acknowledgment connections are chip-specific. For implementation, refer to the Chip Configuration information.

35.1.4 DAC External Trigger Input Connections

The implementation of DAC external trigger inputs is chip-specific. Refer to the Chip Configuration information for details.

35.1.5 Block Diagram

This diagram illustrates the major components of the PDB.

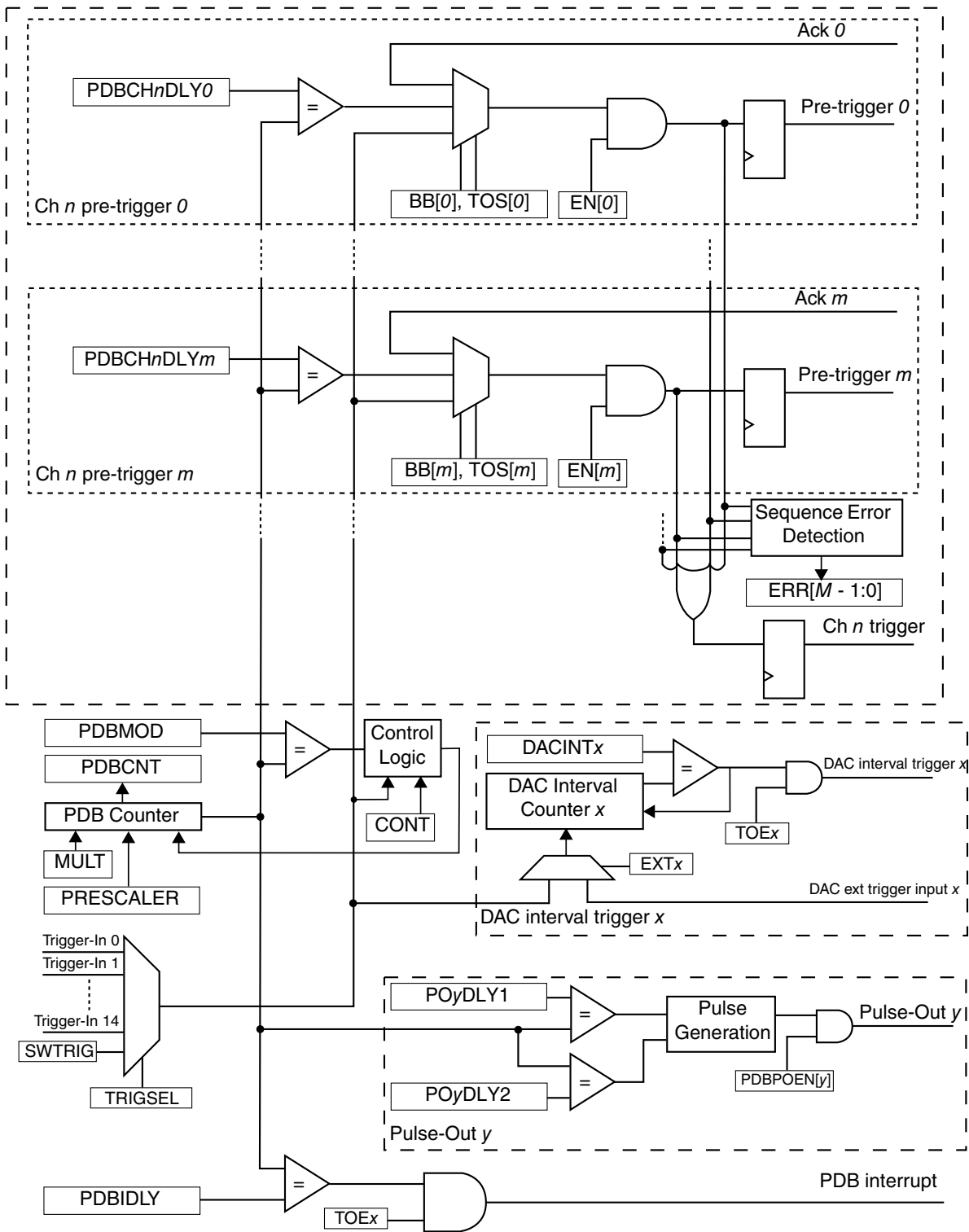

Figure 35-1. PDB Block Diagram

In this diagram, only one PDB channel n , one DAC interval trigger x , and one Pulse-Out y is shown. The PDB enable control logic and the sequence error interrupt logic is not shown.

35.1.6 Modes of Operation

PDB ADC trigger operates in the following modes.

Disabled: Counter is off, all pre-trigger and trigger outputs are low if PDB is not in back-to-back operation of Bypass mode.

Debug: Counter is paused when processor is in debug mode, the counter for dac trigger also paused in Debug mode.

Enabled One-Shot: Counter is enabled and restarted at count zero upon receiving a positive edge on the selected trigger input source or software trigger is selected and SC[SWTRIG] is written with 1. In each PDB channel, an enabled pre-trigger asserts once per trigger input event; the trigger output asserts whenever any of pre-triggers is asserted.

Enabled Continuous: Counter is enabled and restarted at count zero. The counter is rolled over to zero again when the count reaches the value specified in the modulus register, and the counting is restarted. This enables a continuous stream of pre-triggers/trigger outputs as a result of a single trigger input event.

Enabled Bypassed: The pre-trigger and trigger outputs assert immediately after a positive edge on the selected trigger input source or software trigger is selected and SC[SWTRIG] is written with 1, that is the delay registers are bypassed. It is possible to bypass any one or more of the delay registers; therefore this mode can be used in conjunction with One-Shot or Continuous mode.

35.2 PDB Signal Descriptions

This table shows the detailed description of the external signal.

Table 35-1. PDB Signal Descriptions

Signal	Description	I/O
EXTRG	External trigger input source. If the PDB is enabled and external trigger input source is selected, a positive edge on the EXTRG signal resets and starts the counter.	I

35.3 Memory Map and Register Definition

PDB memory map

Absolute address (hex)	Register name	Width (in bits)	Access	Reset value	Section/page
4003_6000	Status and Control Register (PDB0_SC)	32	R/W	0000_0000h	35.3.1/779
4003_6004	Modulus Register (PDB0_MOD)	32	R/W	0000_FFFFh	35.3.2/781
4003_6008	Counter Register (PDB0_CNT)	32	R	0000_0000h	35.3.3/782
4003_600C	Interrupt Delay Register (PDB0_IDLY)	32	R/W	0000_FFFFh	35.3.4/782
4003_6010	Channel n Control Register 1 (PDB0_CH0C1)	32	R/W	0000_0000h	35.3.5/783
4003_6014	Channel n Status Register (PDB0_CH0S)	32	w1c	0000_0000h	35.3.6/784
4003_6018	Channel n Delay 0 Register (PDB0_CH0DLY0)	32	R/W	0000_0000h	35.3.7/785
4003_601C	Channel n Delay 1 Register (PDB0_CH0DLY1)	32	R/W	0000_0000h	35.3.8/785
4003_6038	Channel n Control Register 1 (PDB0_CH1C1)	32	R/W	0000_0000h	35.3.5/783
4003_603C	Channel n Status Register (PDB0_CH1S)	32	w1c	0000_0000h	35.3.6/784
4003_6040	Channel n Delay 0 Register (PDB0_CH1DLY0)	32	R/W	0000_0000h	35.3.7/785
4003_6044	Channel n Delay 1 Register (PDB0_CH1DLY1)	32	R/W	0000_0000h	35.3.8/785
4003_6150	DAC Interval Trigger n Control Register (PDB0_DACINTC0)	32	R/W	0000_0000h	35.3.9/786
4003_6154	DAC Interval n Register (PDB0_DACINT0)	32	R/W	0000_0000h	35.3.10/786
4003_6158	DAC Interval Trigger n Control Register (PDB0_DACINTC1)	32	R/W	0000_0000h	35.3.9/786
4003_615C	DAC Interval n Register (PDB0_DACINT1)	32	R/W	0000_0000h	35.3.10/786
4003_6190	Pulse-Out n Enable Register (PDB0_PO0EN)	32	R/W	0000_0000h	35.3.11/787
4003_6194	Pulse-Out n Delay Register (PDB0_PO0DLY)	32	R/W	0000_0000h	35.3.12/787

35.3.1 Status and Control Register (PDBx_SC)

Addresses: PDB0_SC is 4003_6000h base + 0h offset = 4003_6000h

Bit	31	30	29	28	27	26	25	24	23	22	21	20	19	18	17	16
R	0								LDMOD				PDBEIE	0		
W														SWTRIG		
Reset	0	0	0	0	0	0	0	0	0	0	0	0	0	0	0	0
Bit	15	14	13	12	11	10	9	8	7	6	5	4	3	2	1	0
R	DMAEN	PRESCALER				TRGSEL				PDBEN	PDBIF	PDBIE	0	MULT	CONT	LDOK
W																
Reset	0	0	0	0	0	0	0	0	0	0	0	0	0	0	0	0

PDBx_SC field descriptions

Field	Description
31–20 Reserved	This read-only field is reserved and always has the value zero.
19–18 LDMOD	Load Mode Select Selects the mode to load the MOD, IDLY, CHnDLYm, INTx, and POyDLY registers, after 1 is written to LDOK. 00 The internal registers are loaded with the values from their buffers immediately after 1 is written to LDOK. 01 The internal registers are loaded with the values from their buffers when the PDB counter reaches the MOD register value after 1 is written to LDOK. 10 The internal registers are loaded with the values from their buffers when a trigger input event is detected after 1 is written to LDOK. 11 The internal registers are loaded with the values from their buffers when either the PDB counter reaches the MOD register value or a trigger input event is detected, after 1 is written to LDOK.
17 PDBEIE	PDB Sequence Error Interrupt Enable This bit enables the PDB sequence error interrupt. When this bit is set, any of the PDB channel sequence error flags generates a PDB sequence error interrupt. 0 PDB sequence error interrupt disabled. 1 PDB sequence error interrupt enabled.
16 SWTRIG	Software Trigger When PDB is enabled and the software trigger is selected as the trigger input source, writing 1 to this bit reset and restarts the counter. Writing 0 to this bit has no effect. Reading this bit results 0.

Table continues on the next page...

PDBx_SC field descriptions (continued)

Field	Description
15 DMAEN	<p>DMA Enable</p> <p>When DMA is enabled, the PDBIF flag generates a DMA request instead of an interrupt.</p> <p>0 DMA disabled 1 DMA enabled</p>
14–12 PRESCALER	<p>Prescaler Divider Select</p> <p>000 Counting uses the peripheral clock divided by multiplication factor selected by MULT. 001 Counting uses the peripheral clock divided by twice of the multiplication factor selected by MULT. 010 Counting uses the peripheral clock divided by four times of the multiplication factor selected by MULT. 011 Counting uses the peripheral clock divided by eight times of the multiplication factor selected by MULT. 100 Counting uses the peripheral clock divided by 16 times of the multiplication factor selected by MULT. 101 Counting uses the peripheral clock divided by 32 times of the multiplication factor selected by MULT. 110 Counting uses the peripheral clock divided by 64 times of the multiplication factor selected by MULT. 111 Counting uses the peripheral clock divided by 128 times of the multiplication factor selected by MULT.</p>
11–8 TRGSEL	<p>Trigger Input Source Select</p> <p>Selects the trigger input source for the PDB. The trigger input source can be internal or external (EXTRG pin), or the software trigger.</p> <p>0000 Trigger-In 0 is selected 0001 Trigger-In 1 is selected 0010 Trigger-In 2 is selected 0011 Trigger-In 3 is selected 0100 Trigger-In 4 is selected 0101 Trigger-In 5 is selected 0110 Trigger-In 6 is selected 0111 Trigger-In 7 is selected 1000 Trigger-In 8 is selected 1001 Trigger-In 9 is selected 1010 Trigger-In 10 is selected 1011 Trigger-In 11 is selected 1100 Trigger-In 12 is selected 1101 Trigger-In 13 is selected 1110 Trigger-In 14 is selected 1111 Software trigger is selected</p>
7 PDBEN	<p>PDB Enable</p> <p>0 PDB disabled. Counter is off. 1 PDB enabled</p>
6 PDBIF	<p>PDB Interrupt Flag</p>

Table continues on the next page...

PDBx_SC field descriptions (continued)

Field	Description
	This bit is set when the counter value is equal to the IDLY register. Writing zero clears this bit.
5 PDBIE	<p>PDB Interrupt Enable.</p> <p>This bit enables the PDB interrupt. When this bit is set and DMAEN is cleared, PDBIF generates a PDB interrupt.</p> <p>0 PDB interrupt disabled 1 PDB interrupt enabled</p>
4 Reserved	This read-only field is reserved and always has the value zero.
3–2 MULT	<p>Multiplication Factor Select for Prescaler</p> <p>This bit selects the multiplication factor of the prescaler divider for the counter clock.</p> <p>00 Multiplication factor is 1 01 Multiplication factor is 10 10 Multiplication factor is 20 11 Multiplication factor is 40</p>
1 CONT	<p>Continuous Mode Enable</p> <p>This bit enables the PDB operation in Continuous mode.</p> <p>0 PDB operation in One-Shot mode 1 PDB operation in Continuous mode</p>
0 LDOK	<p>Load OK</p> <p>Writing 1 to this bit updates the internal registers of MOD, IDLY, CHnDLYm, DACINTx, and POyDLY with the values written to their buffers. The MOD, IDLY, CHnDLYm, DACINTx, and POyDLY will take effect according to the LDMOD.</p> <p>After 1 is written to LDOK bit, the values in the buffers of above registers are not effective and the buffers cannot be written until the values in buffers are loaded into their internal registers.</p> <p>LDOK can be written only when PDBEN is set or it can be written at the same time with PDBEN being written to 1. It is automatically cleared when the values in buffers are loaded into the internal registers or the PDBEN is cleared. Writing 0 to it has no effect.</p>

35.3.2 Modulus Register (PDBx_MOD)

Addresses: PDB0_MOD is 4003_6000h base + 4h offset = 4003_6004h

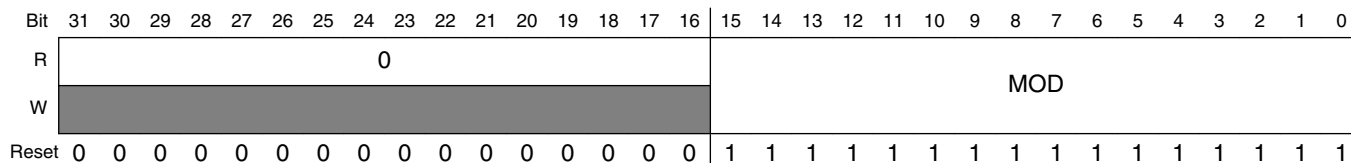

PDBx_MOD field descriptions

Field	Description
31–16 Reserved	This read-only field is reserved and always has the value zero.
15–0 MOD	PDB Modulus. These bits specify the period of the counter. When the counter reaches this value, it will be reset back to zero. If the PDB is in Continuous mode, the count begins anew. Reading these bits returns the value of internal register that is effective for the current cycle of PDB.

35.3.3 Counter Register (PDBx_CNT)

Addresses: PDB0_CNT is 4003_6000h base + 8h offset = 4003_6008h

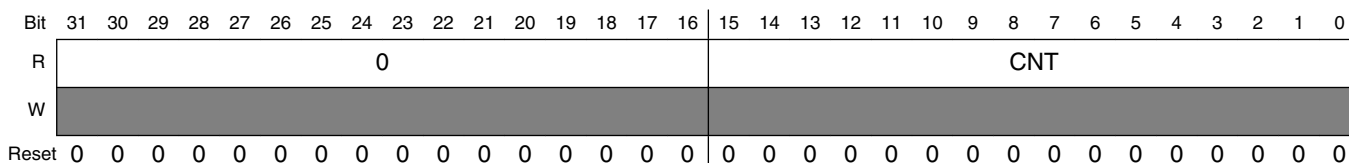

PDBx_CNT field descriptions

Field	Description
31–16 Reserved	This read-only field is reserved and always has the value zero.
15–0 CNT	PDB Counter These read-only bits contain the current value of the counter.

35.3.4 Interrupt Delay Register (PDBx_IDLY)

Addresses: PDB0_IDLY is 4003_6000h base + Ch offset = 4003_600Ch

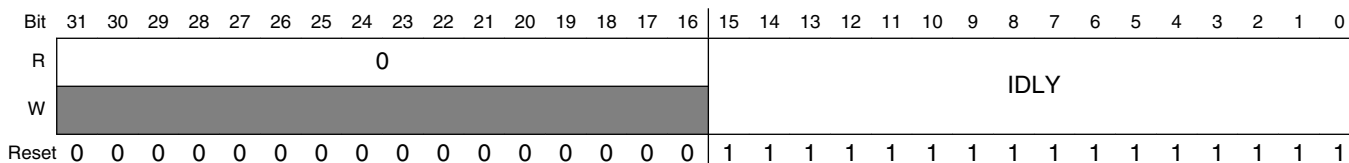

PDBx_IDLY field descriptions

Field	Description
31–16 Reserved	This read-only field is reserved and always has the value zero.
15–0 IDLY	PDB Interrupt Delay

Table continues on the next page...

PDBx_IDLY field descriptions (continued)

Field	Description
	These bits specify the delay value to schedule the PDB interrupt. It can be used to schedule an independent interrupt at some point in the PDB cycle. If enabled, a PDB interrupt is generated, when the counter is equal to the IDLY. Reading these bits returns the value of internal register that is effective for the current cycle of the PDB.

35.3.5 Channel n Control Register 1 (PDBx_CHC1)

Each PDB channel has one Control Register, CHnC1. The bits in this register control the functionality of each PDB channel operation.

Addresses: PDB0_CH0C1 is 4003_6000h base + 10h offset = 4003_6010h

PDB0_CH1C1 is 4003_6000h base + 38h offset = 4003_6038h

Bit	31	30	29	28	27	26	25	24	23	22	21	20	19	18	17	16	15	14	13	12	11	10	9	8	7	6	5	4	3	2	1	0
R	0								BB								TOS				EN											
W	0								0								0				0											
Reset	0	0	0	0	0	0	0	0	0	0	0	0	0	0	0	0	0	0	0	0	0	0	0	0	0	0	0	0	0	0	0	0

PDBx_CHnC1 field descriptions

Field	Description
31–24 Reserved	This read-only field is reserved and always has the value zero.
23–16 BB	<p>PDB Channel Pre-Trigger Back-to-Back Operation Enable</p> <p>These bits enable the PDB ADC pre-trigger operation as back-to-back mode. Only lower M pre-trigger bits are implemented in this MCU. Back-to-back operation enables the ADC conversions complete to trigger the next PDB channel pre-trigger and trigger output, so that the ADC conversions can be triggered on next set of configuration and results registers. Application code must only enable the back-to-back operation of the PDB pre-triggers at the leading of the back-to-back connection chain.</p> <p>0 PDB channel's corresponding pre-trigger back-to-back operation disabled. 1 PDB channel's corresponding pre-trigger back-to-back operation enabled.</p>
15–8 TOS	<p>PDB Channel Pre-Trigger Output Select</p> <p>These bits select the PDB ADC pre-trigger outputs. Only lower M pre-trigger bits are implemented in this MCU.</p> <p>0 PDB channel's corresponding pre-trigger is in bypassed mode. The pre-trigger asserts one peripheral clock cycle after a rising edge is detected on selected trigger input source or software trigger is selected and SWTRIG is written with 1. 1 PDB channel's corresponding pre-trigger asserts when the counter reaches the channel delay register plus one peripheral clock cycle after a rising edge is detected on selected trigger input source or software trigger is selected and SETRIG is written with 1.</p>
7–0 EN	PDB Channel Pre-Trigger Enable

Table continues on the next page...

PDBx_CHnC1 field descriptions (continued)

Field	Description
	These bits enable the PDB ADC pre-trigger outputs. Only lower M pre-trigger bits are implemented in this MCU.
0	PDB channel's corresponding pre-trigger disabled.
1	PDB channel's corresponding pre-trigger enabled.

35.3.6 Channel n Status Register (PDBx_CHS)

Addresses: PDB0_CH0S is 4003_6000h base + 14h offset = 4003_6014h

PDB0_CH1S is 4003_6000h base + 3Ch offset = 4003_603Ch

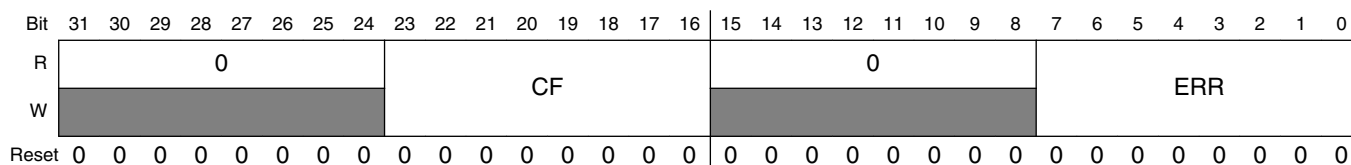

PDBx_CHnS field descriptions

Field	Description
31–24 Reserved	This read-only field is reserved and always has the value zero.
23–16 CF	PDB Channel Flags The CF[m] bit is set when the PDB counter matches the CHnDLYm. Write 0 to clear these bits.
15–8 Reserved	This read-only field is reserved and always has the value zero.
7–0 ERR	PDB Channel Sequence Error Flags Only the lower M bits are implemented in this MCU. 0 Sequence error not detected on PDB channel's corresponding pre-trigger. 1 Sequence error detected on PDB channel's corresponding pre-trigger. ADCn block can be triggered for a conversion by one pre-trigger from PDB channel n. When one conversion, which is triggered by one of the pre-triggers from PDB channel n, is in progress, new trigger from PDB channel's corresponding pre-trigger m cannot be accepted by ADCn, and ERR[m] is set. Writing 1's to clear the sequence error flags.

35.3.7 Channel n Delay 0 Register (PDBx_CHDLY0)

Addresses: PDB0_CH0DLY0 is 4003_6000h base + 18h offset = 4003_6018h

PDB0_CH1DLY0 is 4003_6000h base + 40h offset = 4003_6040h

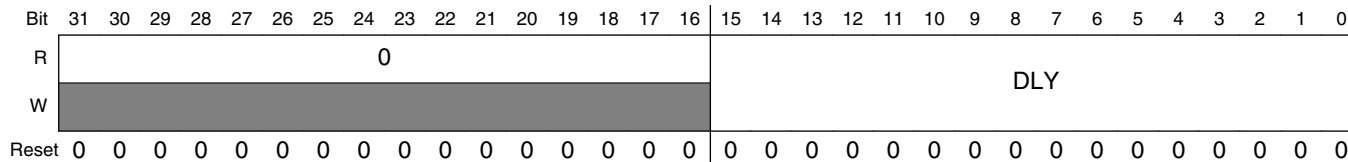

PDBx_CHnDLY0 field descriptions

Field	Description
31–16 Reserved	This read-only field is reserved and always has the value zero.
15–0 DLY	PDB Channel Delay These bits specify the delay value for the channel's corresponding pre-trigger. The pre-trigger asserts when the counter is equal to DLY. Reading these bits returns the value of internal register that is effective for the current PDB cycle.

35.3.8 Channel n Delay 1 Register (PDBx_CHDLY1)

Addresses: PDB0_CH0DLY1 is 4003_6000h base + 1Ch offset = 4003_601Ch

PDB0_CH1DLY1 is 4003_6000h base + 44h offset = 4003_6044h

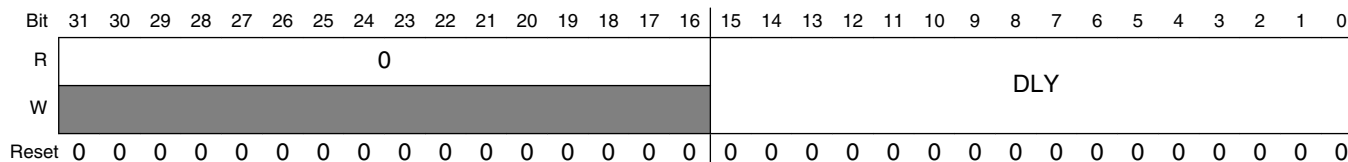

PDBx_CHnDLY1 field descriptions

Field	Description
31–16 Reserved	This read-only field is reserved and always has the value zero.
15–0 DLY	PDB Channel Delay These bits specify the delay value for the channel's corresponding pre-trigger. The pre-trigger asserts when the counter is equal to DLY. Reading these bits returns the value of internal register that is effective for the current PDB cycle.

35.3.9 DAC Interval Trigger n Control Register (PDBx_DACINTCn)

Addresses: PDB0_DACINTC0 is 4003_6000h base + 150h offset = 4003_6150h

PDB0_DACINTC1 is 4003_6000h base + 158h offset = 4003_6158h

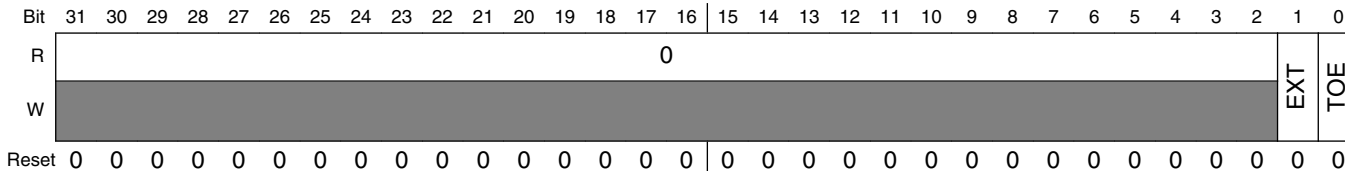

PDBx_DACINTCn field descriptions

Field	Description
31–2 Reserved	This read-only field is reserved and always has the value zero.
1 EXT	DAC External Trigger Input Enable This bit enables the external trigger for DAC interval counter. 0 DAC external trigger input disabled. DAC interval counter is reset and started counting when a rising edge is detected on selected trigger input source or software trigger is selected and SWTRIG is written with 1. 1 DAC external trigger input enabled. DAC interval counter is bypassed and DAC external trigger input triggers the DAC interval trigger.
0 TOE	DAC Interval Trigger Enable This bit enables the DAC interval trigger. 0 DAC interval trigger disabled. 1 DAC interval trigger enabled.

35.3.10 DAC Interval n Register (PDBx_DACINTn)

Addresses: PDB0_DACINT0 is 4003_6000h base + 154h offset = 4003_6154h

PDB0_DACINT1 is 4003_6000h base + 15Ch offset = 4003_615Ch

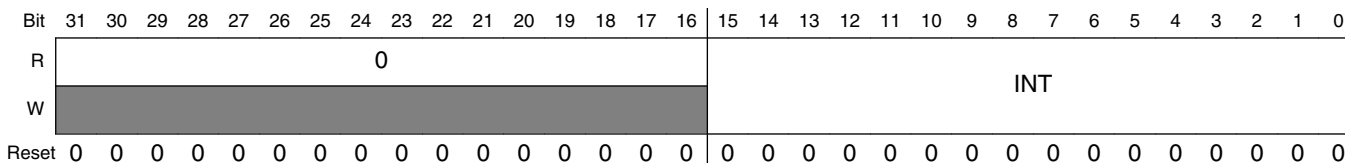

PDBx_DACINTn field descriptions

Field	Description
31–16 Reserved	This read-only field is reserved and always has the value zero.

Table continues on the next page...

PDBx_DACINTn field descriptions (continued)

Field	Description
15–0 INT	<p>DAC Interval</p> <p>These bits specify the interval value for DAC interval trigger. DAC interval trigger triggers DAC[1:0] update when the DAC interval counter is equal to the DACINT. Reading these bits returns the value of internal register that is effective for the current PDB cycle.</p>

35.3.11 Pulse-Out n Enable Register (PDBx_POEN)

Addresses: PDB0_PO0EN is 4003_6000h base + 190h offset = 4003_6190h

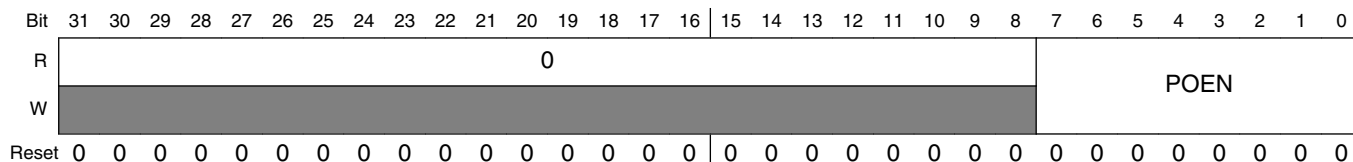

PDBx_POnEN field descriptions

Field	Description
31–8 Reserved	This read-only field is reserved and always has the value zero.
7–0 POEN	<p>PDB Pulse-Out Enable</p> <p>These bits enable the pulse output. Only lower Y bits are implemented in this MCU.</p> <p>0 PDB Pulse-Out disabled 1 PDB Pulse-Out enabled</p>

35.3.12 Pulse-Out n Delay Register (PDBx_PODLY)

Addresses: PDB0_PO0DLY is 4003_6000h base + 194h offset = 4003_6194h

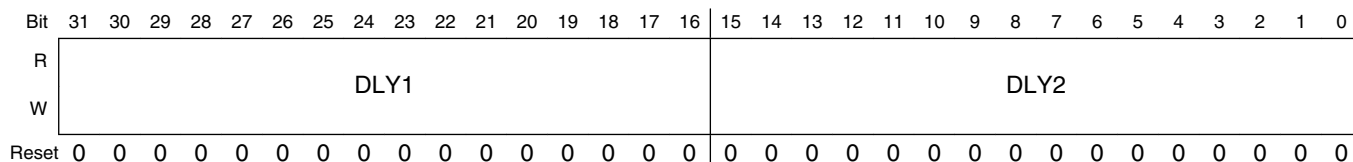

PDBx_POnDLY field descriptions

Field	Description
31–16 DLY1	PDB Pulse-Out Delay 1

Table continues on the next page...

PDBx_POnDLY field descriptions (continued)

Field	Description
	These bits specify the delay 1 value for the PDB Pulse-Out. Pulse-Out goes high when the PDB counter is equal to the DLY1. Reading these bits returns the value of internal register that is effective for the current PDB cycle.
15–0 DLY2	<p>PDB Pulse-Out Delay 2</p> <p>These bits specify the delay 2 value for the PDB Pulse-Out. Pulse-Out goes low when the PDB counter is equal to the DLY2. Reading these bits returns the value of internal register that is effective for the current PDB cycle.</p>

35.4 Functional Description

35.4.1 PDB Pre-trigger and Trigger Outputs

The PDB contains a counter whose output is compared against several different digital values. If the PDB is enabled, a trigger input event will reset the counter and make it start to count. A trigger input event is defined as a rising edge being detected on selected trigger input source or software trigger being selected and SC[SWTRIG] is written with 1. For each channel, delay m determines the time between assertion of the trigger input event to the point at which changes in the pre-trigger m output signal is initiated. The time is defined as:

- Trigger input event to pre-trigger $m = (\text{prescaler} \times \text{multiplication factor} \times \text{delay } m) + 2$ peripheral clock cycles
- Add one additional peripheral clock cycle to determine the time at which the channel trigger output change.

Each channel is associated with one ADC block. PDB channel n pre-trigger outputs 0 to M and trigger output is connected to ADC hardware trigger select and hardware trigger inputs. The pre-triggers are used to precondition the ADC block prior to the actual trigger. The ADC contains M sets of configuration and result registers, allowing it to operate in a ping-pong fashion, alternating conversions between M different analog sources. The pre-trigger outputs are used to specify which signal will be sampled next. When pre-trigger m is asserted, the ADC conversion is triggered with set m of the configuration and result registers.

The waveforms shown in the following diagram illuminate the pre-trigger and trigger outputs of PDB channel n . The delays can be independently set via the $CHnDLYm$ registers. And the pre-triggers can be enabled or disabled in $CHnC1[EN[m]]$.

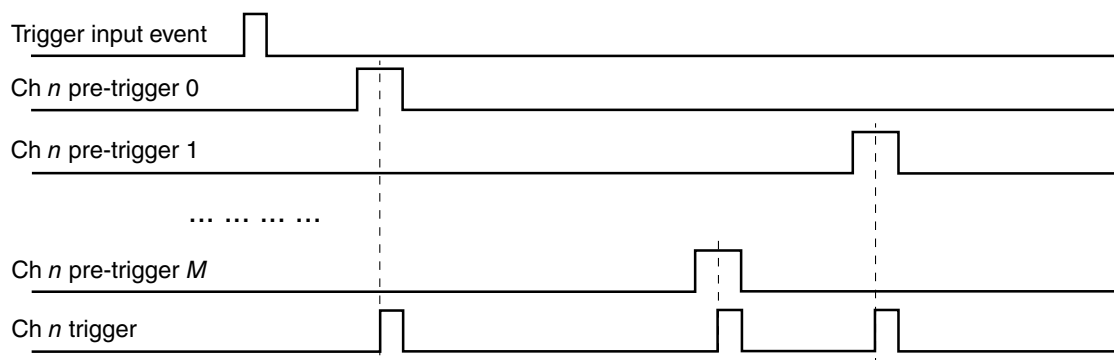

Figure 35-54. Pre-trigger and Trigger Outputs

The delay in $CHnDLYm$ register can be optionally bypassed, if $CHnC1[TOS[m]]$ is cleared. In this case, when the trigger input event occurs, the pre-trigger m is asserted after two peripheral clock cycles.

The PDB can be configured in back-to-back (B2B) operation. B2B operation enables the ADC conversions complete to trigger the next PDB channel pre-trigger and trigger outputs, so that the ADC conversions can be triggered on next set of configuration and results registers. When B2B is enabled by setting $CHnC1[BB[m]]$, the delay m is ignored and the pre-trigger m is asserted two peripheral cycles after the acknowledgment m is received. The acknowledgment connections in this MCU is described in [Back-to-back Acknowledgement Connections](#).

When an ADC conversion, which is triggered by one of the pre-triggers from PDB channel n , is in progress and $ADCnSC1[COCO]$ is not set, a new trigger from PDB channel n pre-trigger m cannot be accepted by $ADCn$. Therefore every time when one PDB channel n pre-trigger and trigger output starts an ADC conversion, an internal lock associated with the corresponding pre-trigger is activated. The lock becomes inactive when the corresponding $ADCnSC1[COCO]$ is set, or the corresponding PDB pre-trigger is disabled, or the PDB is disabled. The channel n trigger output is suppressed when any of the locks of the pre-triggers in channel n is active. If a new pre-trigger m asserts when there is active lock in the PDB channel n , a register flag bit, $CHnS[ERR[m]]$, associated with the pre-trigger m is set. If $SC[PDBEIE]$ is set, the sequence error interrupt is generated. Sequence error is typically happened because the delay m is set too short and the pre-trigger m asserts before the previous triggered ADC conversion is completed.

When the PDB counter reaches the value set in $IDLY$ register, the $SC[PDBIF]$ flag is set. A PDB interrupt can be generated if $SC[PDBIE]$ is set and $SC[DMAEN]$ is cleared. If $SC[DMAEN]$ is set, PDB requests a DMA transfer when $SC[PDBIF]$ is set.

The modulus value in MOD register, is used to reset the counter back to zero at the end of the count. If $SC[CONT]$ bit is set, the counter will then resume a new count. Otherwise, the counter operation will cease until the next trigger input event occurs.

35.4.2 PDB Trigger Input Source Selection

The PDB has up to 15 trigger input sources, namely Trigger-In 0 to 14. They are connected to on-chip or off-chip event sources. The PDB can be triggered by software through the SC[SWTRIG]. SC[TRIGSEL] bits select the active trigger input source or software trigger.

For the trigger input sources implemented in this MCU, refer to Chip Configuration information.

35.4.3 DAC Interval Trigger Outputs

PDB can generate the interval triggers for DACs to update their outputs periodically. DAC interval counter x is reset and started when a trigger input event occurs if DACINTC x [EXT] is cleared. When the interval counter x is equal to the value set in DACINT x register, the DAC interval trigger x output generates a pulse of one peripheral clock cycle width to update the DAC x . If DACINTC x [EXT] is set, the DAC interval counter is bypassed and the interval trigger output x generates a pulse following the detection of a rising edge on the DAC external trigger input. The counter and interval trigger can be disabled by clearing the DACINTC x [TOE].

DAC interval counters are also reset when the PDB counter reaches the MOD register value, therefore when the PDB counter rolls over to zero, the DAC interval counters starts anew.

Together, the DAC interval trigger pulse and the ADC pre-trigger/trigger pulses allow precise timing of DAC updates and ADC measurements. This is outlined in the typical use case described in the following diagram.

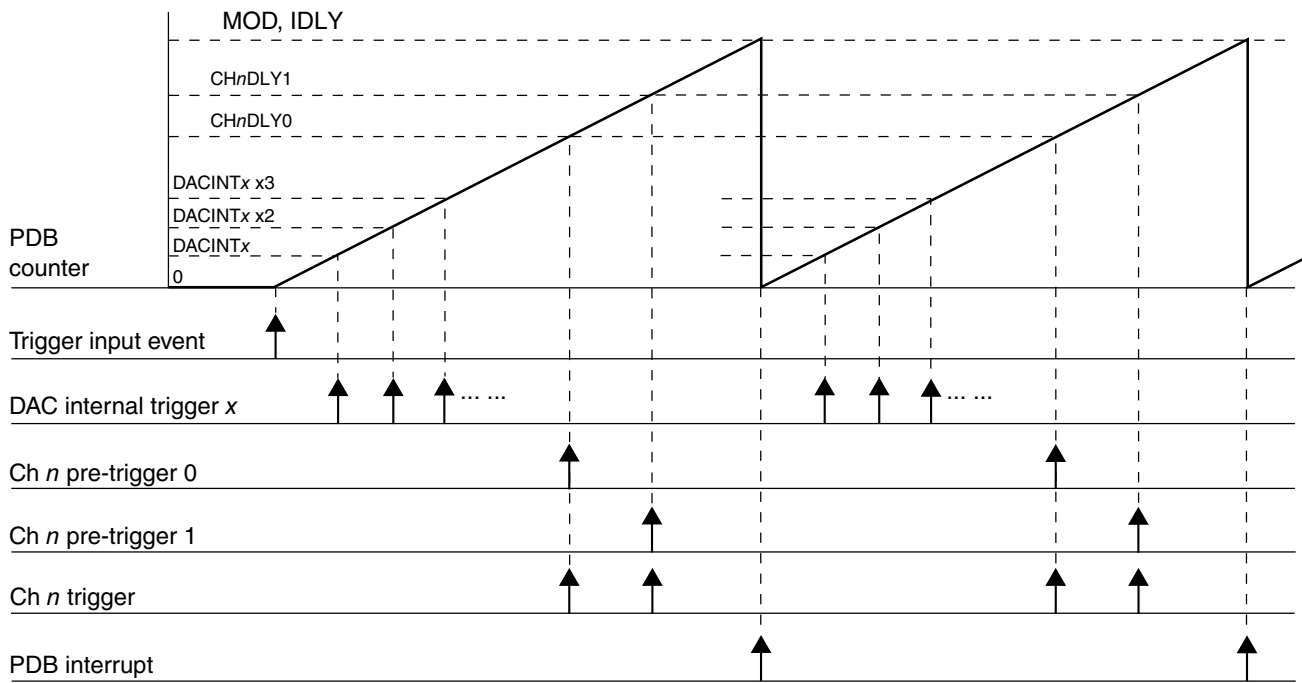

Figure 35-55. PDB ADC Triggers and DAC Interval Triggers Use Case

NOTE

Because the DAC interval counters share the prescaler with PDB counter, PDB must be enabled if the DAC interval trigger outputs are used in the applications.

35.4.4 Pulse-Out's

PDB can generate pulse outputs of configurable width. When PDB counter reaches the value set in PO_yDLY[DLY1], the Pulse-Out goes high; when the counter reaches PO_yDLY[DLY2], it goes low. PO_yDLY[DLY2] can be set either greater or less than PO_yDLY[DLY1].

Because the PDB counter is shared by both ADC pre-trigger/trigger outputs and Pulse-Out generation, they have the same time base.

The pulse-out connections implemented in this MCU are described in the device's Chip Configuration details.

35.4.5 Updating the Delay Registers

The following registers control the timing of the PDB operation; and in some of the applications, they may need to become effective at the same time.

Functional Description

- PDB Modulus Register (MOD)
- PDB Interrupt Delay Register (IDLY)
- PDB Channel n Delay m Register (CH n DLY m)
- DAC Interval x Register (DACINT x)
- PDB Pulse-Out y Delay Register (PO y DLY)

The internal registers of them are buffered and any values written to them are written first to their buffers. The circumstances that cause their internal registers to be updated with the values from the buffers are summarized as below table.

Table 35-56. Circumstances of Update to the Delay Registers

SC[LDMOD]	Update to the Delay Registers
00	The internal registers are loaded with the values from their buffers immediately after 1 is written to SC[LDOK].
01	The PDB counter reaches the MOD register value after 1 is written to SC[LDOK].
10	A trigger input event is detected after 1 is written to SC[LDOK].
11	Either the PDB counter reaches the MOD register value, or a trigger input event is detected, after 1 is written to SC[LDOK].

After 1 is written to SC[LDOK], the buffers cannot be written until the values in buffers are loaded into their internal registers. SC[LDOK] is self-cleared when the internal registers are loaded, so the application code can read it to determine the updates of the internal registers.

The following diagrams show the cases of the internal registers being updated with SC[LDMOD] is 00 and x1.

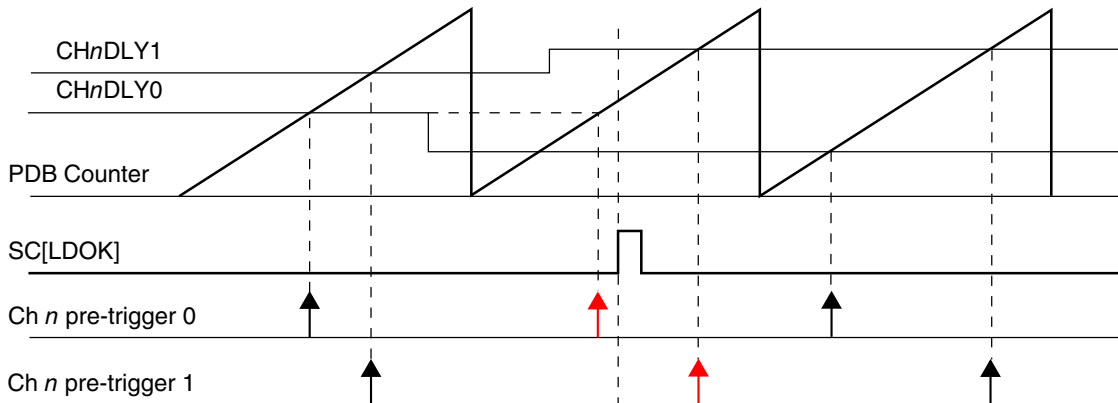

Figure 35-56. Registers Update with SC[LDMOD] = 00

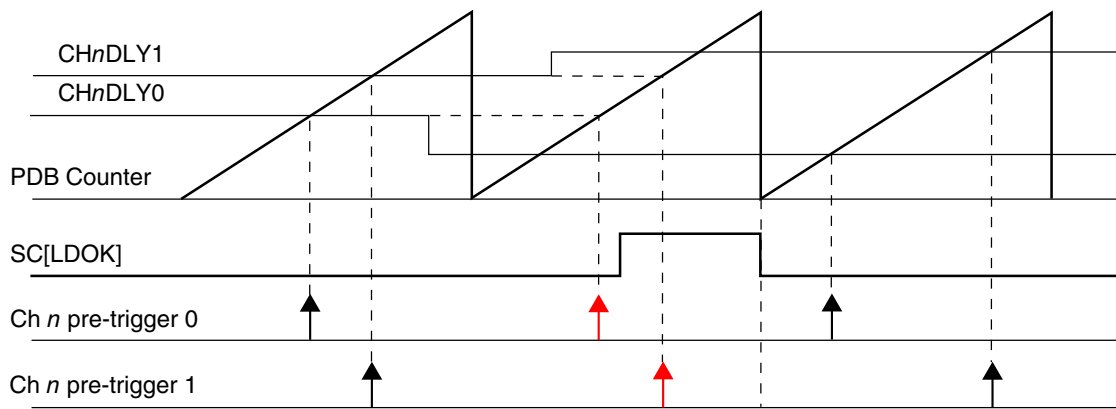

Figure 35-57. Registers Update with SC[LDMOD] = x1

35.4.6 Interrupts

PDB can generate two interrupts, PDB interrupt and PDB sequence error interrupt. The following table summarizes the interrupts.

Table 35-57. PDB Interrupt Summary

Interrupt	Flags	Enable Bit
PDB Interrupt	SC[PDBIF]	SC[PDBIE] = 1 and SC[DMAEN] = 0
PDB Sequence Error Interrupt	CHnS[ERRm]	SC[PDBEIE] = 1

35.4.7 DMA

If SC[DMAEN] is set, PDB can generate DMA transfer request when SC[PDBIF] is set. When DMA is enabled, the PDB interrupt will not be issued.

35.5 Application Information

35.5.1 Impact of Using the Prescaler and Multiplication Factor on Timing Resolution

Use of prescaler and multiplication factor greater than 1 limits the count/delay accuracy in terms of peripheral clock cycles (to the modulus of the prescaler X multiplication factor). If the multiplication factor is set to 1 and the prescaler is set to 2 then the only

values of total peripheral clocks that can be detected are even values; if prescaler is set to 4 then the only values of total peripheral clocks that can be decoded as detected are mod(4) and so forth. If the applications need a really long delay value and use 128, then the resolution would be limited to 128 peripheral clock cycles.

Therefore, use the lowest possible prescaler and multiplication factor for a given application.

Chapter 36

FlexTimer (FTM)

36.1 Introduction

NOTE

For the chip-specific implementation details of this module's instances see the chip configuration chapter.

The FlexTimer Module (FTM) is a two to eight channel timer which supports input capture, output compare, and the generation of PWM signals to control electric motor and power management applications. The FTM time reference is a 16-bit counter that can be used as an unsigned or signed counter.

36.1.1 FlexTimer Philosophy

The FlexTimer is built upon a very simple timer (HCS08 Timer PWM Module – TPM) used for many years on Freescales 8 bit microcontrollers. The FlexTimer extends the functionality to meet the demands of motor control, digital lighting solutions and power conversion yet providing low cost and backwards compatibility with the TPM module.

Several key enhancements are made; signed up counter, deadtime insertion hardware, fault control inputs, enhanced triggering functionality and initialization and polarity control.

All the features common with the TPM module have fully backwards compatible register assignments and the FlexTimer can use code on the same core platform without change to perform the same functions.

Motor control and power conversion features have been added through a dedicated set of registers and defaults turn off all new features. The new features such as hardware deadtime insertion, polarity, fault control and output forcing and masking greatly reduce loading on the execution software and are usually each controlled by a group of registers.

FlexTimer input triggers can be from comparators, ADC or other sub modules to initiate timer functions automatically. These triggers can be linked in a variety of ways during integration of the sub modules so please note carefully the options available for used FlexTimer configuration.

Several FlexTimers may be synchronized to provide a larger timer with their counters incrementing in unison, assuming the initialization, the input clocks, the initial and final counting values are the same in each FlexTimer.

All main user access registers are buffered to ease the load on the executing software. A number of trigger options exist to determine which registers are updated with this user defined data.

36.1.2 Features

The FTM features include:

- FTM source clock is selectable
 - Source clock can be the system clock, the fixed frequency clock, or an external clock
 - Fixed frequency clock is an additional clock input to allow the selection of an on chip clock source other than the system clock
 - Selecting external clock connects FTM clock to a chip level input pin therefore allowing to synchronize the FTM counter with an off chip clock source
- Prescaler divide-by 1, 2, 4, 8, 16, 32, 64, or 128
- FTM has a 16-bit counter
 - It can be a free-running counter or a counter with initial and final value
 - The counting can be up or up-down
- Each channel can be configured for input capture, output compare, or edge-aligned PWM mode
- In input capture mode
 - the capture can occur on rising edges, falling edges or both edges
 - an input filter can be selected for some channels
- In output compare mode the output signal can be set, cleared, or toggled on match
- All channels can be configured for center-aligned PWM mode

- Each pair of channels can be combined to generate a PWM signal (with independent control of both edges of PWM signal)
- The FTM channels can operate as pairs with equal outputs, pairs with complementary outputs, or independent channels (with independent outputs)
- The deadtime insertion is available for each complementary pair
- Generation of triggers (match trigger)
- Software control of PWM outputs
- Up to 4 fault inputs for global fault control
- The polarity of each channel is configurable
- The generation of an interrupt per channel
- The generation of an interrupt when the counter overflows
- The generation of an interrupt when the fault condition is detected
- Synchronized loading of write buffered FTM registers
- Write protection for critical registers
- Backwards compatible with TPM
- Testing of input captures for a stuck at zero and one conditions
- Dual edge capture for pulse and period width measurement
- Quadrature decoder with input filters, relative position counting and interrupt on position count or capture of position count on external event

36.1.3 Modes of Operation

When the MCU is in an active BDM mode, the FTM temporarily suspends all counting until the MCU returns to normal user operating mode. During stop mode, all FTM input clocks are stopped, so the FTM is effectively disabled until clocks resume. During wait mode, the FTM continues to operate normally. If the FTM does not need to produce a real time reference or provide the interrupt sources needed to wake the MCU from wait mode, the power can then be saved by disabling FTM functions before entering wait mode.

36.1.4 Block Diagram

The FTM uses one input/output (I/O) pin per channel, CHn (FTM channel (n)) where n is the channel number (0–7).

The following figure shows the FTM structure. The central component of the FTM is the 16-bit counter with programmable initial and final values and its counting can be up or up-down.

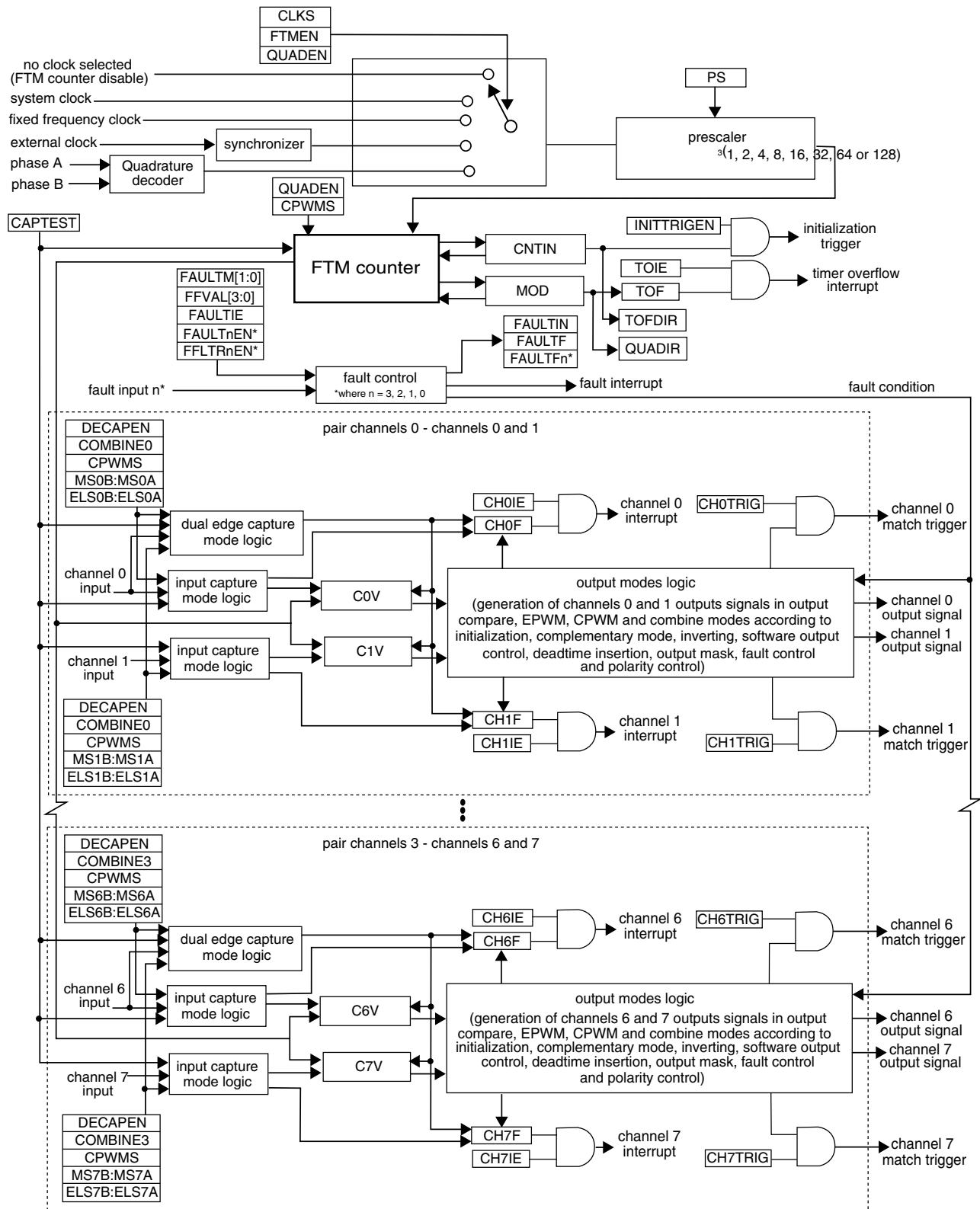

Figure 36-1. FTM Block Diagram

36.2 FTM Signal Descriptions

Table 36-1 shows the user-accessible signals for the FTM.

Table 36-1. FTM Signal Descriptions

Signal	Description	I/O
EXTCLK	External clock. FTM external clock can be selected to drive the FTM counter.	I
CHn	FTM channel (n), where n can be 7-0	I/O
FAULTj	Fault input (j), where j can be 3-0	I
PHA	Quadrature decoder phase A input. Input pin associated with quadrature decoder phase A.	I
PHB	Quadrature decoder phase B input. Input pin associated with quadrature decoder phase B.	I

36.2.1 EXTCLK — FTM External Clock

The external clock input signal is used as the FTM counter clock if selected by CLKS[1:0] bits in the SC register. This clock signal must not exceed 1/4 of system clock frequency. The FTM counter prescaler selection and settings are also used when an external clock is selected.

36.2.2 CHn — FTM Channel (n) I/O Pin

Each FTM channel can be configured to operate either as input or output. The direction associated with each channel, input or output, is selected according to the mode assigned for that channel.

36.2.3 FAULTj — FTM Fault Input

The fault input signals are used to control the CHn channel output state. If a fault is detected, the FAULTj signal is asserted and the channel output is put in a safe state. The behavior of the fault logic is defined by the FAULTM[1:0] control bits in the MODE register and FAULTEN bit in the COMBINEm register. Note that each FAULTj input may affect all channels selectively since FAULTM[1:0] and FAULTEN control bits are

defined for each pair of channels. Since there are several FAULTj inputs, maximum of 4 for the FTM module, each one of these inputs is activated by the FAULTjEN bit in the FLTCTRL register.

36.2.4 PHA — FTM Quadrature Decoder Phase A Input

The quadrature decoder phase A input is used as the quadrature decoder mode is selected. The phase A input signal is one of the signals that control the FTM counter increment or decrement in the quadrature decoder mode ([Quadrature Decoder Mode](#)).

36.2.5 PHB — FTM Quadrature Decoder Phase B Input

The quadrature decoder phase B input is used as the quadrature decoder mode is selected. The phase B input signal is one of the signals that control the FTM counter increment or decrement in the quadrature decoder mode ([Quadrature Decoder Mode](#)).

36.3 Memory Map and Register Definition

This section provides a detailed description of all FTM registers.

36.3.1 Module Memory Map

This section presents a high-level summary of the FTM registers and how they are mapped.

The first set has the original TPM registers.

The second set has the FTM specific registers. Any second set registers (or bits within these registers) that are used by an unavailable function in the FTM configuration remain in the memory map and in the reset value, so they have no active function.

Note

Do not write to the FTM specific registers (second set registers) when FTMMEN = 0.

36.3.2 Register Descriptions

This section consists of register descriptions in address order.

Accesses to reserved addresses result in transfer errors. Registers for absent channels are considered reserved.

FTM memory map

Absolute address (hex)	Register name	Width (in bits)	Access	Reset value	Section/ page
4003_8000	Status and Control (FTM0_SC)	32	R/W	0000_0000h	36.3.3/808
4003_8004	Counter (FTM0_CNT)	32	R/W	0000_0000h	36.3.4/809
4003_8008	Modulo (FTM0_MOD)	32	R/W	0000_0000h	36.3.5/810
4003_800C	Channel (n) Status and Control (FTM0_C0SC)	32	R/W	0000_0000h	36.3.6/811
4003_8010	Channel (n) Value (FTM0_C0V)	32	R/W	0000_0000h	36.3.7/814
4003_8014	Channel (n) Status and Control (FTM0_C1SC)	32	R/W	0000_0000h	36.3.6/811
4003_8018	Channel (n) Value (FTM0_C1V)	32	R/W	0000_0000h	36.3.7/814
4003_801C	Channel (n) Status and Control (FTM0_C2SC)	32	R/W	0000_0000h	36.3.6/811
4003_8020	Channel (n) Value (FTM0_C2V)	32	R/W	0000_0000h	36.3.7/814
4003_8024	Channel (n) Status and Control (FTM0_C3SC)	32	R/W	0000_0000h	36.3.6/811
4003_8028	Channel (n) Value (FTM0_C3V)	32	R/W	0000_0000h	36.3.7/814
4003_802C	Channel (n) Status and Control (FTM0_C4SC)	32	R/W	0000_0000h	36.3.6/811
4003_8030	Channel (n) Value (FTM0_C4V)	32	R/W	0000_0000h	36.3.7/814
4003_8034	Channel (n) Status and Control (FTM0_C5SC)	32	R/W	0000_0000h	36.3.6/811
4003_8038	Channel (n) Value (FTM0_C5V)	32	R/W	0000_0000h	36.3.7/814
4003_803C	Channel (n) Status and Control (FTM0_C6SC)	32	R/W	0000_0000h	36.3.6/811

Table continues on the next page...

FTM memory map (continued)

Absolute address (hex)	Register name	Width (in bits)	Access	Reset value	Section/page
4003_8040	Channel (n) Value (FTM0_C6V)	32	R/W	0000_0000h	36.3.7/814
4003_8044	Channel (n) Status and Control (FTM0_C7SC)	32	R/W	0000_0000h	36.3.6/811
4003_8048	Channel (n) Value (FTM0_C7V)	32	R/W	0000_0000h	36.3.7/814
4003_804C	Counter Initial Value (FTM0_CNTIN)	32	R/W	0000_0000h	36.3.8/815
4003_8050	Capture and Compare Status (FTM0_STATUS)	32	R/W	0000_0000h	36.3.9/815
4003_8054	Features Mode Selection (FTM0_MODE)	32	R/W	0000_0004h	36.3.10/818
4003_8058	Synchronization (FTM0_SYNC)	32	R/W	0000_0000h	36.3.11/819
4003_805C	Initial State for Channels Output (FTM0_OUTINIT)	32	R/W	0000_0000h	36.3.12/822
4003_8060	Output Mask (FTM0_OUTMASK)	32	R/W	0000_0000h	36.3.13/823
4003_8064	Function for Linked Channels (FTM0_COMBINE)	32	R/W	0000_0000h	36.3.14/825
4003_8068	Deadtime Insertion Control (FTM0_DEADTIME)	32	R/W	0000_0000h	36.3.15/830
4003_806C	FTM External Trigger (FTM0_EXTTRIG)	32	R/W	0000_0000h	36.3.16/831
4003_8070	Channels Polarity (FTM0_POL)	32	R/W	0000_0000h	36.3.17/833
4003_8074	Fault Mode Status (FTM0_FMS)	32	R/W	0000_0000h	36.3.18/835
4003_8078	Input Capture Filter Control (FTM0_FILTER)	32	R/W	0000_0000h	36.3.19/837
4003_807C	Fault Control (FTM0_FLTCTRL)	32	R/W	0000_0000h	36.3.20/839
4003_8080	Quadrature Decoder Control and Status (FTM0_QDCTRL)	32	R/W	0000_0000h	36.3.21/841
4003_8084	Configuration (FTM0_CONF)	32	R/W	0000_0000h	36.3.22/843
4003_8088	FTM Fault Input Polarity (FTM0_FLTPOL)	32	R/W	0000_0000h	36.3.23/844
4003_808C	Synchronization Configuration (FTM0_SYNCONF)	32	R/W	0000_0000h	36.3.24/846

Table continues on the next page...

FTM memory map (continued)

Absolute address (hex)	Register name	Width (in bits)	Access	Reset value	Section/page
4003_8090	FTM Inverting Control (FTM0_INVCTRL)	32	R/W	0000_0000h	36.3.25/848
4003_8094	FTM Software Output Control (FTM0_SWOCTRL)	32	R/W	0000_0000h	36.3.26/849
4003_8098	FTM PWM Load (FTM0_PWMLOAD)	32	R/W	0000_0000h	36.3.27/851
4003_9000	Status and Control (FTM1_SC)	32	R/W	0000_0000h	36.3.3/808
4003_9004	Counter (FTM1_CNT)	32	R/W	0000_0000h	36.3.4/809
4003_9008	Modulo (FTM1_MOD)	32	R/W	0000_0000h	36.3.5/810
4003_900C	Channel (n) Status and Control (FTM1_C0SC)	32	R/W	0000_0000h	36.3.6/811
4003_9010	Channel (n) Value (FTM1_C0V)	32	R/W	0000_0000h	36.3.7/814
4003_9014	Channel (n) Status and Control (FTM1_C1SC)	32	R/W	0000_0000h	36.3.6/811
4003_9018	Channel (n) Value (FTM1_C1V)	32	R/W	0000_0000h	36.3.7/814
4003_901C	Channel (n) Status and Control (FTM1_C2SC)	32	R/W	0000_0000h	36.3.6/811
4003_9020	Channel (n) Value (FTM1_C2V)	32	R/W	0000_0000h	36.3.7/814
4003_9024	Channel (n) Status and Control (FTM1_C3SC)	32	R/W	0000_0000h	36.3.6/811
4003_9028	Channel (n) Value (FTM1_C3V)	32	R/W	0000_0000h	36.3.7/814
4003_902C	Channel (n) Status and Control (FTM1_C4SC)	32	R/W	0000_0000h	36.3.6/811
4003_9030	Channel (n) Value (FTM1_C4V)	32	R/W	0000_0000h	36.3.7/814
4003_9034	Channel (n) Status and Control (FTM1_C5SC)	32	R/W	0000_0000h	36.3.6/811
4003_9038	Channel (n) Value (FTM1_C5V)	32	R/W	0000_0000h	36.3.7/814
4003_903C	Channel (n) Status and Control (FTM1_C6SC)	32	R/W	0000_0000h	36.3.6/811
4003_9040	Channel (n) Value (FTM1_C6V)	32	R/W	0000_0000h	36.3.7/814

Table continues on the next page...

FTM memory map (continued)

Absolute address (hex)	Register name	Width (in bits)	Access	Reset value	Section/page
4003_9044	Channel (n) Status and Control (FTM1_C7SC)	32	R/W	0000_0000h	36.3.6/811
4003_9048	Channel (n) Value (FTM1_C7V)	32	R/W	0000_0000h	36.3.7/814
4003_904C	Counter Initial Value (FTM1_CNTIN)	32	R/W	0000_0000h	36.3.8/815
4003_9050	Capture and Compare Status (FTM1_STATUS)	32	R/W	0000_0000h	36.3.9/815
4003_9054	Features Mode Selection (FTM1_MODE)	32	R/W	0000_0004h	36.3.10/818
4003_9058	Synchronization (FTM1_SYNC)	32	R/W	0000_0000h	36.3.11/819
4003_905C	Initial State for Channels Output (FTM1_OUTINIT)	32	R/W	0000_0000h	36.3.12/822
4003_9060	Output Mask (FTM1_OUTMASK)	32	R/W	0000_0000h	36.3.13/823
4003_9064	Function for Linked Channels (FTM1_COMBINE)	32	R/W	0000_0000h	36.3.14/825
4003_9068	Deadtime Insertion Control (FTM1_DEADTIME)	32	R/W	0000_0000h	36.3.15/830
4003_906C	FTM External Trigger (FTM1_EXTTRIG)	32	R/W	0000_0000h	36.3.16/831
4003_9070	Channels Polarity (FTM1_POL)	32	R/W	0000_0000h	36.3.17/833
4003_9074	Fault Mode Status (FTM1_FMS)	32	R/W	0000_0000h	36.3.18/835
4003_9078	Input Capture Filter Control (FTM1_FILTER)	32	R/W	0000_0000h	36.3.19/837
4003_907C	Fault Control (FTM1_FLTCTRL)	32	R/W	0000_0000h	36.3.20/839
4003_9080	Quadrature Decoder Control and Status (FTM1_QDCTRL)	32	R/W	0000_0000h	36.3.21/841
4003_9084	Configuration (FTM1_CONF)	32	R/W	0000_0000h	36.3.22/843
4003_9088	FTM Fault Input Polarity (FTM1_FLTPOL)	32	R/W	0000_0000h	36.3.23/844
4003_908C	Synchronization Configuration (FTM1_SYNCONF)	32	R/W	0000_0000h	36.3.24/846
4003_9090	FTM Inverting Control (FTM1_INVCTRL)	32	R/W	0000_0000h	36.3.25/848

Table continues on the next page...

FTM memory map (continued)

Absolute address (hex)	Register name	Width (in bits)	Access	Reset value	Section/page
4003_9094	FTM Software Output Control (FTM1_SWOCTRL)	32	R/W	0000_0000h	36.3.26/849
4003_9098	FTM PWM Load (FTM1_PWMLOAD)	32	R/W	0000_0000h	36.3.27/851
400B_8000	Status and Control (FTM2_SC)	32	R/W	0000_0000h	36.3.3/808
400B_8004	Counter (FTM2_CNT)	32	R/W	0000_0000h	36.3.4/809
400B_8008	Modulo (FTM2_MOD)	32	R/W	0000_0000h	36.3.5/810
400B_800C	Channel (n) Status and Control (FTM2_C0SC)	32	R/W	0000_0000h	36.3.6/811
400B_8010	Channel (n) Value (FTM2_C0V)	32	R/W	0000_0000h	36.3.7/814
400B_8014	Channel (n) Status and Control (FTM2_C1SC)	32	R/W	0000_0000h	36.3.6/811
400B_8018	Channel (n) Value (FTM2_C1V)	32	R/W	0000_0000h	36.3.7/814
400B_801C	Channel (n) Status and Control (FTM2_C2SC)	32	R/W	0000_0000h	36.3.6/811
400B_8020	Channel (n) Value (FTM2_C2V)	32	R/W	0000_0000h	36.3.7/814
400B_8024	Channel (n) Status and Control (FTM2_C3SC)	32	R/W	0000_0000h	36.3.6/811
400B_8028	Channel (n) Value (FTM2_C3V)	32	R/W	0000_0000h	36.3.7/814
400B_802C	Channel (n) Status and Control (FTM2_C4SC)	32	R/W	0000_0000h	36.3.6/811
400B_8030	Channel (n) Value (FTM2_C4V)	32	R/W	0000_0000h	36.3.7/814
400B_8034	Channel (n) Status and Control (FTM2_C5SC)	32	R/W	0000_0000h	36.3.6/811
400B_8038	Channel (n) Value (FTM2_C5V)	32	R/W	0000_0000h	36.3.7/814
400B_803C	Channel (n) Status and Control (FTM2_C6SC)	32	R/W	0000_0000h	36.3.6/811
400B_8040	Channel (n) Value (FTM2_C6V)	32	R/W	0000_0000h	36.3.7/814
400B_8044	Channel (n) Status and Control (FTM2_C7SC)	32	R/W	0000_0000h	36.3.6/811

Table continues on the next page...

FTM memory map (continued)

Absolute address (hex)	Register name	Width (in bits)	Access	Reset value	Section/page
400B_8048	Channel (n) Value (FTM2_C7V)	32	R/W	0000_0000h	36.3.7/814
400B_804C	Counter Initial Value (FTM2_CNTIN)	32	R/W	0000_0000h	36.3.8/815
400B_8050	Capture and Compare Status (FTM2_STATUS)	32	R/W	0000_0000h	36.3.9/815
400B_8054	Features Mode Selection (FTM2_MODE)	32	R/W	0000_0004h	36.3.10/818
400B_8058	Synchronization (FTM2_SYNC)	32	R/W	0000_0000h	36.3.11/819
400B_805C	Initial State for Channels Output (FTM2_OUTINIT)	32	R/W	0000_0000h	36.3.12/822
400B_8060	Output Mask (FTM2_OUTMASK)	32	R/W	0000_0000h	36.3.13/823
400B_8064	Function for Linked Channels (FTM2_COMBINE)	32	R/W	0000_0000h	36.3.14/825
400B_8068	Deadtime Insertion Control (FTM2_DEADTIME)	32	R/W	0000_0000h	36.3.15/830
400B_806C	FTM External Trigger (FTM2_EXTTRIG)	32	R/W	0000_0000h	36.3.16/831
400B_8070	Channels Polarity (FTM2_POL)	32	R/W	0000_0000h	36.3.17/833
400B_8074	Fault Mode Status (FTM2_FMS)	32	R/W	0000_0000h	36.3.18/835
400B_8078	Input Capture Filter Control (FTM2_FILTER)	32	R/W	0000_0000h	36.3.19/837
400B_807C	Fault Control (FTM2_FLTCTRL)	32	R/W	0000_0000h	36.3.20/839
400B_8080	Quadrature Decoder Control and Status (FTM2_QDCTRL)	32	R/W	0000_0000h	36.3.21/841
400B_8084	Configuration (FTM2_CONF)	32	R/W	0000_0000h	36.3.22/843
400B_8088	FTM Fault Input Polarity (FTM2_FLTPOL)	32	R/W	0000_0000h	36.3.23/844
400B_808C	Synchronization Configuration (FTM2_SYNCONF)	32	R/W	0000_0000h	36.3.24/846
400B_8090	FTM Inverting Control (FTM2_INVCTRL)	32	R/W	0000_0000h	36.3.25/848
400B_8094	FTM Software Output Control (FTM2_SWOCTRL)	32	R/W	0000_0000h	36.3.26/849

Table continues on the next page...

FTM memory map (continued)

Absolute address (hex)	Register name	Width (in bits)	Access	Reset value	Section/page
400B_8098	FTM PWM Load (FTM2_PWMLOAD)	32	R/W	0000_0000h	36.3.27/ 851

36.3.3 Status and Control (FTMx_SC)

SC contains the overflow status flag and control bits used to configure the interrupt enable, FTM configuration, clock source, and prescaler factor. These controls relate to all channels within this module.

Addresses: FTM0_SC is 4003_8000h base + 0h offset = 4003_8000h
 FTM1_SC is 4003_9000h base + 0h offset = 4003_9000h
 FTM2_SC is 400B_8000h base + 0h offset = 400B_8000h

Bit	31	30	29	28	27	26	25	24	23	22	21	20	19	18	17	16
R	0															
W	[Shaded]															
Reset	0	0	0	0	0	0	0	0	0	0	0	0	0	0	0	0
Bit	15	14	13	12	11	10	9	8	7	6	5	4	3	2	1	0
R	0								TOF	TOIE	CPWMS	CLKS		PS		
W	[Shaded]								0							
Reset	0	0	0	0	0	0	0	0	0	0	0	0	0	0	0	0

FTMx_SC field descriptions

Field	Description
31–8 Reserved	This read-only field is reserved and always has the value zero.
7 TOF	<p>Timer Overflow Flag</p> <p>Set by hardware when the FTM counter passes the value in the MOD register. The TOF bit is cleared by reading the SC register while TOF is set and then writing a 0 to TOF bit. Writing a 1 to TOF has no effect.</p> <p>If another FTM overflow occurs between the read and write operations, the write operation has no effect; therefore, TOF remains set indicating an overflow has occurred. In this case a TOF interrupt request is not lost due to the clearing sequence for a previous TOF.</p> <p>0 FTM counter has not overflowed. 1 FTM counter has overflowed.</p>
6 TOIE	<p>Timer Overflow Interrupt Enable</p> <p>Enables FTM overflow interrupts.</p>

Table continues on the next page...

FTMx_SC field descriptions (continued)

Field	Description
	0 Disable TOF interrupts. Use software polling. 1 Enable TOF interrupts. An interrupt is generated when TOF equals one.
5 CPWMS	Center-aligned PWM Select Selects CPWM mode. This mode configures the FTM to operate in up-down counting mode. This field is write protected. It can be written only when MODE[WPDIS] = 1. 0 FTM counter operates in up counting mode. 1 FTM counter operates in up-down counting mode.
4–3 CLKS	Clock Source Selection Selects one of the three FTM counter clock sources. This field is write protected. It can be written only when MODE[WPDIS] = 1. 00 No clock selected (This in effect disables the FTM counter.) 01 System clock 10 Fixed frequency clock 11 External clock
2–0 PS	Prescale Factor Selection Selects one of 8 division factors for the clock source selected by CLKS. The new prescaler factor affects the clock source on the next system clock cycle after the new value is updated into the register bits. This field is write protected. It can be written only when MODE[WPDIS] = 1. 000 Divide by 1 001 Divide by 2 010 Divide by 4 011 Divide by 8 100 Divide by 16 101 Divide by 32 110 Divide by 64 111 Divide by 128

36.3.4 Counter (FTMx_CNT)

The CNT register contains the FTM counter value.

Reset clears the CNT register. Writing any value to COUNT updates the counter with its initial value (CNTIN).

When BDM is active, the FTM counter is frozen (this is the value that you may read).

memory Map and Register Definition

Addresses: FTM0_CNT is 4003_8000h base + 4h offset = 4003_8004h

FTM1_CNT is 4003_9000h base + 4h offset = 4003_9004h

FTM2_CNT is 400B_8000h base + 4h offset = 400B_8004h

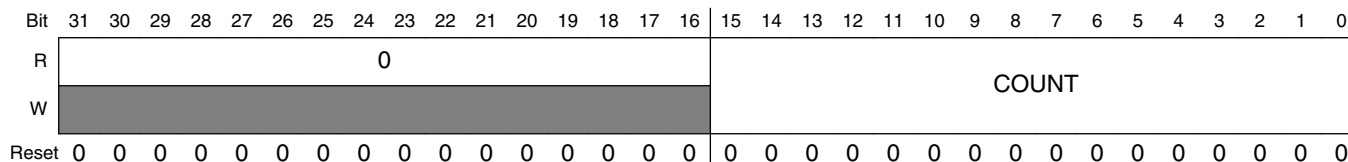

FTMx_CNT field descriptions

Field	Description
31–16 Reserved	This read-only field is reserved and always has the value zero.
15–0 COUNT	Counter value

36.3.5 Modulo (FTMx_MOD)

The Modulo register contains the modulo value for the FTM counter. After the FTM counter reaches the modulo value, the overflow flag (TOF) becomes set at the next clock, and the next value of FTM counter depends on the selected counting method ([Counter](#)).

Writing to the MOD register latches the value into a buffer. The MOD register is updated with the value of its write buffer according to [Registers Updated from Write Buffers](#).

If FTMEN = 0, this write coherency mechanism may be manually reset by writing to the SC register (whether BDM is active or not).

It is recommended to initialize the FTM counter (write to CNT) before writing to the MOD register to avoid confusion about when the first counter overflow will occur.

Addresses: FTM0_MOD is 4003_8000h base + 8h offset = 4003_8008h

FTM1_MOD is 4003_9000h base + 8h offset = 4003_9008h

FTM2_MOD is 400B_8000h base + 8h offset = 400B_8008h

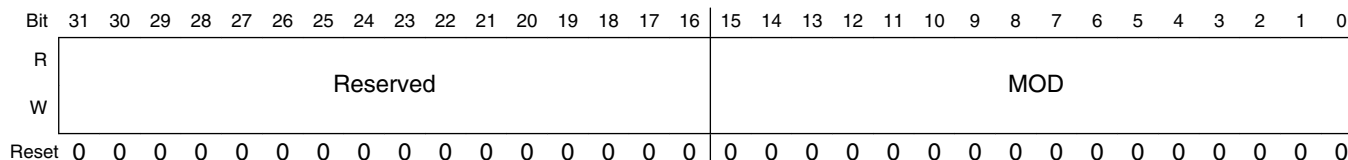

FTMx_MOD field descriptions

Field	Description
31–16 Reserved	This field is reserved.

Table continues on the next page...

FTMx_MOD field descriptions (continued)

Field	Description
15–0 MOD	Modulo value

36.3.6 Channel (n) Status and Control (FTMx_CSC)

CnSC contains the channel-interrupt-status flag and control bits used to configure the interrupt enable, channel configuration, and pin function.

Table 36-67. Mode, Edge, and Level Selection

DECAPEN	COMBINE	CPWMS	MSnB:MSnA	ELSnB:ELSnA	Mode	Configuration
X	X	X	XX	0	None	Pin not used for FTM

Table continues on the next page...

Table 36-67. Mode, Edge, and Level Selection (continued)

DECAPEN	COMBINE	CPWMS	MSnB:MSnA	ELSnB:ELSnA	Mode	Configuration		
0	0	0	0	1	Input capture	Capture on Rising Edge Only		
				10		Capture on Falling Edge Only		
				11		Capture on Rising or Falling Edge		
			1	1	Output compare	Toggle Output on match		
				10		Clear Output on match		
				11		Set Output on match		
		1X	10	Edge-aligned PWM	High-true pulses (clear Output on match)			
					X1	Low-true pulses (set Output on match)		
		1	XX		10	Center-aligned PWM	High-true pulses (clear Output on match-up)	
							X1	Low-true pulses (set Output on match-up)
		1	0		XX	10	Combine PWM	High-true pulses (set on channel (n) match, and clear on channel (n+1) match)
								X1
1	0	0	X0	See the following table (Table 36-8).	Dual Edge Capture Mode	One-shot capture mode		
			X1			Continuous capture mode		

Table 36-68. Dual Edge Capture Mode — Edge Polarity Selection

ELSnB	ELSnA	Channel Port Enable	Detected Edges
0	0	Disabled	No edge
0	1	Enabled	Rising edge
1	0	Enabled	Falling edge
1	1	Enabled	Rising and falling edges

Addresses: FTM0_C0SC is 4003_8000h base + Ch offset = 4003_800Ch

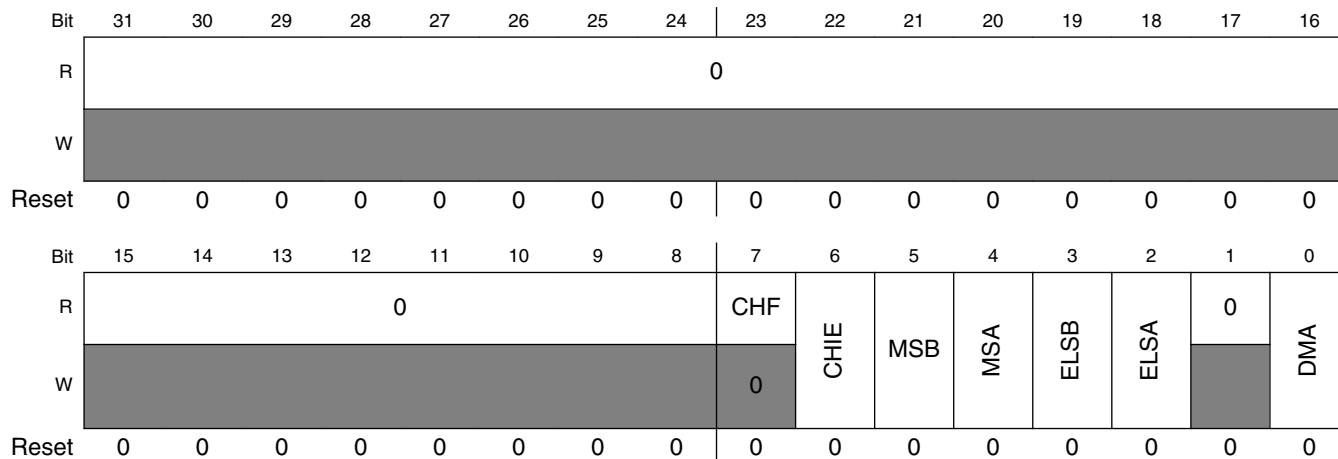

FTMx_CnSC field descriptions

Field	Description
31–8 Reserved	This read-only field is reserved and always has the value zero.
7 CHF	<p>Channel Flag</p> <p>Set by hardware when an event occurs on the channel. CHF is cleared by reading the CSC register while CHnF is set and then writing a 0 to the CHF bit. Writing a 1 to CHF has no effect.</p> <p>If another event occurs between the read and write operations, the write operation has no effect; therefore, CHF remains set indicating an event has occurred. In this case a CHF interrupt request is not lost due to the clearing sequence for a previous CHF.</p> <p>0 No channel event has occurred. 1 A channel event has occurred.</p>
6 CHIE	<p>Channel Interrupt Enable</p> <p>Enables channel interrupts.</p> <p>0 Disable channel interrupts. Use software polling. 1 Enable channel interrupts.</p>
5 MSB	<p>Channel Mode Select</p> <p>Used for further selections in the channel logic. Its functionality is dependent on the channel mode. See Table 36-7.</p>

Table continues on the next page...

FTMx_CnSC field descriptions (continued)

Field	Description
	This field is write protected. It can be written only when MODE[WPDIS] = 1.
4 MSA	Channel Mode Select Used for further selections in the channel logic. Its functionality is dependent on the channel mode. See Table 36-7 . This field is write protected. It can be written only when MODE[WPDIS] = 1.
3 ELSB	Edge or Level Select The functionality of ELSB and ELSA depends on the channel mode. See Table 36-7 . This field is write protected. It can be written only when MODE[WPDIS] = 1.
2 ELSA	Edge or Level Select The functionality of ELSB and ELSA depends on the channel mode. See Table 36-7 . This field is write protected. It can be written only when MODE[WPDIS] = 1.
1 Reserved	This read-only field is reserved and always has the value zero.
0 DMA	DMA Enable Enables DMA transfers for the channel. 0 Disable DMA transfers. 1 Enable DMA transfers.

36.3.7 Channel (n) Value (FTMx_CV)

These registers contain the captured FTM counter value for the input modes or the match value for the output modes.

In input capture, capture test, and dual edge capture modes, any write to a CnV register is ignored.

In output modes, writing to a CnV register latches the value into a buffer. A CnV register is updated with the value of its write buffer according to [Registers Updated from Write Buffers](#).

If FTMEN = 0, this write coherency mechanism may be manually reset by writing to the CnSC register (whether BDM mode is active or not).

Addresses: FTM0_C0V is 4003_8000h base + 10h offset = 4003_8010h

Bit	31	30	29	28	27	26	25	24	23	22	21	20	19	18	17	16	15	14	13	12	11	10	9	8	7	6	5	4	3	2	1	0
R	0																VAL															
W	[Greyed out]																VAL															
Reset	0	0	0	0	0	0	0	0	0	0	0	0	0	0	0	0	0	0	0	0	0	0	0	0	0	0	0	0	0	0	0	0

FTMx_CnV field descriptions

Field	Description
31–16 Reserved	This read-only field is reserved and always has the value zero.
15–0 VAL	Channel Value Captured FTM counter value of the input modes or the match value for the output modes

36.3.8 Counter Initial Value (FTMx_CNTIN)

The Counter Initial Value register contains the initial value for the FTM counter.

Writing to the CNTIN register latches the value into a buffer. The CNTIN register is updated with the value of its write buffer according to [Registers Updated from Write Buffers](#).

The first time that the FTM clock is selected (first write to change the CLKS bits to a non-zero value), the FTM counter starts with the value 0x0000. To avoid this behavior, before the first write to select the FTM clock, write the new value to the the CNTIN register and then initialize the FTM counter (write any value to the CNT register).

Addresses: FTM0_CNTIN is 4003_8000h base + 4Ch offset = 4003_804Ch

FTM1_CNTIN is 4003_9000h base + 4Ch offset = 4003_904Ch

FTM2_CNTIN is 400B_8000h base + 4Ch offset = 400B_804Ch

Bit	31	30	29	28	27	26	25	24	23	22	21	20	19	18	17	16	15	14	13	12	11	10	9	8	7	6	5	4	3	2	1	0
R	Reserved																INIT															
W	Reserved																INIT															
Reset	0	0	0	0	0	0	0	0	0	0	0	0	0	0	0	0	0	0	0	0	0	0	0	0	0	0	0	0	0	0	0	0

FTMx_CNTIN field descriptions

Field	Description
31–16 Reserved	This field is reserved.
15–0 INIT	Initial Value of the FTM Counter

36.3.9 Capture and Compare Status (FTMx_STATUS)

The STATUS register contains a copy of the status flag CHnF bit (in CnSC) for each FTM channel for software convenience.

Each CHnF bit in STATUS is a mirror of CHnF bit in CnSC. All CHnF bits can be checked using only one read of STATUS. All CHnF bits can be cleared by reading STATUS followed by writing 0x00 to STATUS.

Hardware sets the individual channel flags when an event occurs on the channel. CHF is cleared by reading STATUS while CHnF is set and then writing a 0 to the CHF bit. Writing a 1 to CHF has no effect.

If another event occurs between the read and write operations, the write operation has no effect; therefore, CHF remains set indicating an event has occurred. In this case a CHF interrupt request is not lost due to the clearing sequence for a previous CHF.

NOTE

The STATUS register should be used only combine mode.

Addresses: FTM0_STATUS is 4003_8000h base + 50h offset = 4003_8050h

FTM1_STATUS is 4003_9000h base + 50h offset = 4003_9050h

FTM2_STATUS is 400B_8000h base + 50h offset = 400B_8050h

Bit	31	30	29	28	27	26	25	24	23	22	21	20	19	18	17	16
R	0															
W	[Greyed out]															
Reset	0	0	0	0	0	0	0	0	0	0	0	0	0	0	0	0
Bit	15	14	13	12	11	10	9	8	7	6	5	4	3	2	1	0
R	0								CH7F	CH6F	CH5F	CH4F	CH3F	CH2F	CH1F	CH0F
W	[Greyed out]								0	0	0	0	0	0	0	0
Reset	0	0	0	0	0	0	0	0	0	0	0	0	0	0	0	0

FTMx_STATUS field descriptions

Field	Description
31–8 Reserved	This read-only field is reserved and always has the value zero.
7 CH7F	Channel 7 Flag See the register description. 0 No channel event has occurred. 1 A channel event has occurred.
6 CH6F	Channel 6 Flag See the register description. 0 No channel event has occurred. 1 A channel event has occurred.
5 CH5F	Channel 5 Flag See the register description.

Table continues on the next page...

FTMx_STATUS field descriptions (continued)

Field	Description
	0 No channel event has occurred. 1 A channel event has occurred.
4 CH4F	Channel 4 Flag See the register description. 0 No channel event has occurred. 1 A channel event has occurred.
3 CH3F	Channel 3 Flag See the register description. 0 No channel event has occurred. 1 A channel event has occurred.
2 CH2F	Channel 2 Flag See the register description. 0 No channel event has occurred. 1 A channel event has occurred.
1 CH1F	Channel 1 Flag See the register description. 0 No channel event has occurred. 1 A channel event has occurred.
0 CH0F	Channel 0 Flag See the register description. 0 No channel event has occurred. 1 A channel event has occurred.

36.3.10 Features Mode Selection (FTM_x_MODE)

This register contains the control bits used to configure the fault interrupt and fault control, capture test mode, PWM synchronization, write protection, channel output initialization, and enable the enhanced features of the FTM. These controls relate to all channels within this module.

Addresses: FTM0_MODE is 4003_8000h base + 54h offset = 4003_8054h

FTM1_MODE is 4003_9000h base + 54h offset = 4003_9054h

FTM2_MODE is 400B_8000h base + 54h offset = 400B_8054h

Bit	31	30	29	28	27	26	25	24	23	22	21	20	19	18	17	16
R	0															
W	[Shaded]															
Reset	0	0	0	0	0	0	0	0	0	0	0	0	0	0	0	0
Bit	15	14	13	12	11	10	9	8	7	6	5	4	3	2	1	0
R	0								FAULTIE	FAULTM		CAPTEST	PWMSYNC	WPDIS	INIT	FTMEN
W	[Shaded]															
Reset	0	0	0	0	0	0	0	0	0	0	0	0	0	1	0	0

FTM_x_MODE field descriptions

Field	Description
31–8 Reserved	This read-only field is reserved and always has the value zero.
7 FAULTIE	<p>Fault Interrupt Enable</p> <p>Enables the generation of an interrupt when a fault is detected by FTM and the FTM fault control is enabled.</p> <p>0 Fault control interrupt is disabled. 1 Fault control interrupt is enabled.</p>
6–5 FAULTM	<p>Fault Control Mode</p> <p>Defines the FTM fault control mode.</p> <p>This field is write protected. It can be written only when MODE[WPDIS] = 1.</p> <p>00 Fault control is disabled for all channels. 01 Fault control is enabled for even channels only (channels 0, 2, 4, and 6), and the selected mode is the manual fault clearing. 10 Fault control is enabled for all channels, and the selected mode is the manual fault clearing. 11 Fault control is enabled for all channels, and the selected mode is the automatic fault clearing.</p>

Table continues on the next page...

FTMx_MODE field descriptions (continued)

Field	Description
4 CAPTEST	<p>Capture Test Mode Enable</p> <p>Enables the capture test mode.</p> <p>This field is write protected. It can be written only when MODE[WPDIS] = 1.</p> <p>0 Capture test mode is disabled. 1 Capture test mode is enabled.</p>
3 PWMSYNC	<p>PWM Synchronization Mode</p> <p>Selects which triggers can be used by MOD, CnV, OUTMASK, and FTM counter synchronization (PWM Synchronization). The PWMSYNC bit configures the synchronization when SYNCMODE is zero.</p> <p>0 No restrictions. Software and hardware triggers can be used by MOD, CnV, OUTMASK, and FTM counter synchronization. 1 Software trigger can only be used by MOD and CnV synchronization, and hardware triggers can only be used by OUTMASK and FTM counter synchronization.</p>
2 WPDIS	<p>Write Protection Disable</p> <p>When write protection is enabled (WPDIS = 0), write protected bits can not be written. When write protection is disabled (WPDIS = 1), write protected bits can be written. The WPDIS bit is the negation of the WPEN bit. WPDIS is cleared when 1 is written to WPEN. WPDIS is set when WPEN bit is read as a 1 and then 1 is written to WPDIS. Writing 0 to WPDIS has no effect.</p> <p>0 Write protection is enabled. 1 Write protection is disabled.</p>
1 INIT	<p>Initialize the Channels Output</p> <p>When a 1 is written to INIT bit the channels output is initialized according to the state of their corresponding bit in the OUTINIT register. Writing a 0 to INIT bit has no effect.</p> <p>The INIT bit is always read as 0.</p>
0 FTMEN	<p>FTM Enable</p> <p>This field is write protected. It can be written only when MODE[WPDIS] = 1.</p> <p>0 Only the TPM-compatible registers (first set of registers) can be used without any restriction. Do not use the FTM-specific registers. 1 All registers including the FTM-specific registers (second set of registers) are available for use with no restrictions.</p>

36.3.11 Synchronization (FTMx_SYNC)

This register configures the PWM synchronization.

A synchronization event can perform the synchronized update of MOD, CV, and OUTMASK registers with the value of their write buffer and the FTM counter initialization.

NOTE

The software trigger (SWSYNC bit) and hardware triggers (TRIG0, TRIG1, and TRIG2 bits) have a potential conflict if used together when SYNCMODE = 0. It is recommended using only hardware or software triggers but not both at the same time, otherwise unpredictable behavior is likely to happen.

The selection of the loading point (CNTMAX and CNTMIN bits) is intended to provide the update of MOD, CNTIN, and CnV registers across all enabled channels simultaneously. The use of the loading point selection together with SYNCMODE = 0 and hardware trigger selection (TRIG0, TRIG1, or TRIG2 bits) is likely to result in unpredictable behavior.

The synchronization event selection also depends on the PWMSYNC (MODE register) and SYNCMODE (SYNCONF register) bits. See [PWM Synchronization](#).

Addresses: FTM0_SYNC is 4003_8000h base + 58h offset = 4003_8058h
 FTM1_SYNC is 4003_9000h base + 58h offset = 4003_9058h
 FTM2_SYNC is 400B_8000h base + 58h offset = 400B_8058h

Bit	31	30	29	28	27	26	25	24	23	22	21	20	19	18	17	16
R	0															
W	[Shaded]															
Reset	0	0	0	0	0	0	0	0	0	0	0	0	0	0	0	0
Bit	15	14	13	12	11	10	9	8	7	6	5	4	3	2	1	0
R	0								SWSYNC	TRIG2	TRIG1	TRIG0	SYNCHOM	REINIT	CNTMAX	CNTMIN
W	[Shaded]															
Reset	0	0	0	0	0	0	0	0	0	0	0	0	0	0	0	0

FTMx_SYNC field descriptions

Field	Description
31–8 Reserved	This read-only field is reserved and always has the value zero.
7 SWSYNC	PWM Synchronization Software Trigger Selects the software trigger as the PWM synchronization trigger. The software trigger happens when a 1 is written to SWSYNC bit.

Table continues on the next page...

FTMx_SYNC field descriptions (continued)

Field	Description
	0 Software trigger is not selected. 1 Software trigger is selected.
6 TRIG2	PWM Synchronization Hardware Trigger 2 Enables hardware trigger 2 to the PWM synchronization. Hardware trigger 2 happens when a rising edge is detected at the trigger 2 input signal. 0 Trigger is disabled. 1 Trigger is enabled.
5 TRIG1	PWM Synchronization Hardware Trigger 1 Enables hardware trigger 1 to the PWM synchronization. Hardware trigger 1 happens when a rising edge is detected at the trigger 1 input signal. 0 Trigger is disabled. 1 Trigger is enabled.
4 TRIG0	PWM Synchronization Hardware Trigger 0 Enables hardware trigger 0 to the PWM synchronization. Hardware trigger 0 happens when a rising edge is detected at the trigger 0 input signal. 0 Trigger is disabled. 1 Trigger is enabled.
3 SYNCHOM	Output Mask Synchronization Selects when the OUTMASK register is updated with the value of its buffer. 0 OUTMASK register is updated with the value of its buffer in all rising edges of the system clock. 1 OUTMASK register is updated with the value of its buffer only by the PWM synchronization.
2 REINIT	FTM Counter Reinitialization by Synchronization (FTM Counter Synchronization) Determines if the FTM counter is reinitialized when the selected trigger for the synchronization is detected. The REINIT bit configures the synchronization when SYNCMODE is zero. 0 FTM counter continues to count normally. 1 FTM counter is updated with its initial value when the selected trigger is detected.
1 CNTMAX	Maximum loading point enable Selects the maximum loading point to PWM synchronization (Boundary Cycle and Loading Points). If CNTMAX is one, the selected loading point is when the FTM counter reaches its maximum value (MOD register). 0 The maximum loading point is disabled. 1 The maximum loading point is enabled.
0 CNTMIN	Minimum loading point enable Selects the minimum loading point to PWM synchronization (Boundary Cycle and Loading Points). If CNTMIN is one, the selected loading point is when the FTM counter reaches its minimum value (CNTIN register).

Table continues on the next page...

FTMx_SYNC field descriptions (continued)

Field	Description
0	The minimum loading point is disabled.
1	The minimum loading point is enabled.

36.3.12 Initial State for Channels Output (FTMx_OUTINIT)

Addresses: FTM0_OUTINIT is 4003_8000h base + 5Ch offset = 4003_805Ch

FTM1_OUTINIT is 4003_9000h base + 5Ch offset = 4003_905Ch

FTM2_OUTINIT is 400B_8000h base + 5Ch offset = 400B_805Ch

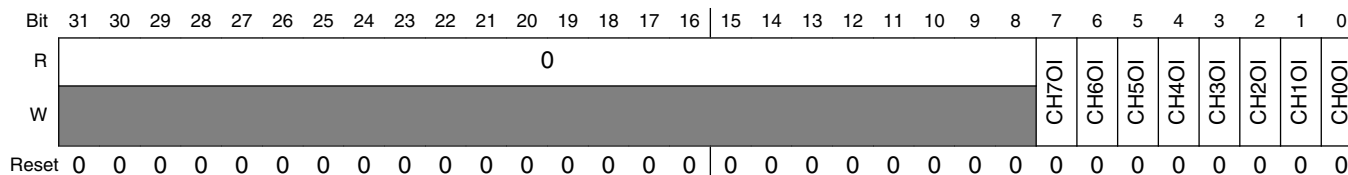

FTMx_OUTINIT field descriptions

Field	Description
31–8 Reserved	This read-only field is reserved and always has the value zero.
7 CH7OI	Channel 7 Output Initialization Value Selects the value that is forced into the channel output when the initialization occurs. 0 The initialization value is 0. 1 The initialization value is 1.
6 CH6OI	Channel 6 Output Initialization Value Selects the value that is forced into the channel output when the initialization occurs. 0 The initialization value is 0. 1 The initialization value is 1.
5 CH5OI	Channel 5 Output Initialization Value Selects the value that is forced into the channel output when the initialization occurs. 0 The initialization value is 0. 1 The initialization value is 1.
4 CH4OI	Channel 4 Output Initialization Value Selects the value that is forced into the channel output when the initialization occurs. 0 The initialization value is 0. 1 The initialization value is 1.
3 CH3OI	Channel 3 Output Initialization Value

Table continues on the next page...

FTMx_OUTINIT field descriptions (continued)

Field	Description
	Selects the value that is forced into the channel output when the initialization occurs. 0 The initialization value is 0. 1 The initialization value is 1.
2 CH2OI	Channel 2 Output Initialization Value Selects the value that is forced into the channel output when the initialization occurs. 0 The initialization value is 0. 1 The initialization value is 1.
1 CH1OI	Channel 1 Output Initialization Value Selects the value that is forced into the channel output when the initialization occurs. 0 The initialization value is 0. 1 The initialization value is 1.
0 CH0OI	Channel 0 Output Initialization Value Selects the value that is forced into the channel output when the initialization occurs. 0 The initialization value is 0. 1 The initialization value is 1.

36.3.13 Output Mask (FTMx_OUTMASK)

This register provides a mask for each FTM channel. The mask of a channel determines if its output responds (that is, it is masked or not) when a match occurs. This feature is used for BLDC control where the PWM signal is presented to an electric motor at specific times to provide electronic commutation.

Any write to the OUTMASK register, stores the value in its write buffer. The register is updated with the value of its write buffer according to [PWM Synchronization](#).

Addresses: FTM0_OUTMASK is 4003_8000h base + 60h offset = 4003_8060h

FTM1_OUTMASK is 4003_9000h base + 60h offset = 4003_9060h

FTM2_OUTMASK is 400B_8000h base + 60h offset = 400B_8060h

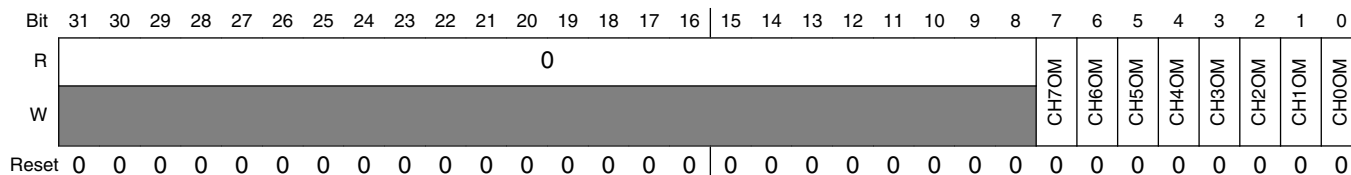

FTMx_OUTMASK field descriptions

Field	Description
31–8 Reserved	This read-only field is reserved and always has the value zero.
7 CH7OM	<p>Channel 7 Output Mask</p> <p>Defines if the channel output is masked (forced to its inactive state) or unmasked (it continues to operate normally).</p> <p>0 Channel output is not masked. It continues to operate normally. 1 Channel output is masked. It is forced to its inactive state.</p>
6 CH6OM	<p>Channel 6 Output Mask</p> <p>Defines if the channel output is masked (forced to its inactive state) or unmasked (it continues to operate normally).</p> <p>0 Channel output is not masked. It continues to operate normally. 1 Channel output is masked. It is forced to its inactive state.</p>
5 CH5OM	<p>Channel 5 Output Mask</p> <p>Defines if the channel output is masked (forced to its inactive state) or unmasked (it continues to operate normally).</p> <p>0 Channel output is not masked. It continues to operate normally. 1 Channel output is masked. It is forced to its inactive state.</p>
4 CH4OM	<p>Channel 4 Output Mask</p> <p>Defines if the channel output is masked (forced to its inactive state) or unmasked (it continues to operate normally).</p> <p>0 Channel output is not masked. It continues to operate normally. 1 Channel output is masked. It is forced to its inactive state.</p>
3 CH3OM	<p>Channel 3 Output Mask</p> <p>Defines if the channel output is masked (forced to its inactive state) or unmasked (it continues to operate normally).</p> <p>0 Channel output is not masked. It continues to operate normally. 1 Channel output is masked. It is forced to its inactive state.</p>
2 CH2OM	<p>Channel 2 Output Mask</p> <p>Defines if the channel output is masked (forced to its inactive state) or unmasked (it continues to operate normally).</p> <p>0 Channel output is not masked. It continues to operate normally. 1 Channel output is masked. It is forced to its inactive state.</p>
1 CH1OM	<p>Channel 1 Output Mask</p> <p>Defines if the channel output is masked (forced to its inactive state) or unmasked (it continues to operate normally).</p> <p>0 Channel output is not masked. It continues to operate normally. 1 Channel output is masked. It is forced to its inactive state.</p>

Table continues on the next page...

FTMx_OUTMASK field descriptions (continued)

Field	Description
0 CH00M	<p>Channel 0 Output Mask</p> <p>Defines if the channel output is masked (forced to its inactive state) or unmasked (it continues to operate normally).</p> <p>0 Channel output is not masked. It continues to operate normally. 1 Channel output is masked. It is forced to its inactive state.</p>

36.3.14 Function for Linked Channels (FTMx_COMBINE)

This register contains the control bits used to configure the fault control, synchronization, deadtime insertion, dual edge capture mode, complementary, and combine mode for each pair of channels (n) and (n+1), where n equals 0, 2, 4, and 6.

Addresses: FTM0_COMBINE is 4003_8000h base + 64h offset = 4003_8064h

FTM1_COMBINE is 4003_9000h base + 64h offset = 4003_9064h

FTM2_COMBINE is 400B_8000h base + 64h offset = 400B_8064h

Bit	31	30	29	28	27	26	25	24	23	22	21	20	19	18	17	16
R	0	FAULTEN3	SYNCEN3	DTEN3	DECAP3	DECAPEN3	COMP3	COMBINE3	0	FAULTEN2	SYNCEN2	DTEN2	DECAP2	DECAPEN2	COMP2	COMBINE2
W																
Reset	0	0	0	0	0	0	0	0	0	0	0	0	0	0	0	0
Bit	15	14	13	12	11	10	9	8	7	6	5	4	3	2	1	0
R	0	FAULTEN1	SYNCEN1	DTEN1	DECAP1	DECAPEN1	COMP1	COMBINE1	0	FAULTEN0	SYNCEN0	DTEN0	DECAP0	DECAPEN0	COMP0	COMBINE0
W																
Reset	0	0	0	0	0	0	0	0	0	0	0	0	0	0	0	0

FTMx_COMBINE field descriptions

Field	Description
31 Reserved	This read-only field is reserved and always has the value zero.
30 FAULTEN3	<p>Fault Control Enable for n = 6</p> <p>Enables the fault control in channels (n) and (n+1).</p> <p>This field is write protected. It can be written only when MODE[WPDIS] = 1.</p> <p>0 The fault control in this pair of channels is disabled. 1 The fault control in this pair of channels is enabled.</p>

Table continues on the next page...

FTMx_COMBINE field descriptions (continued)

Field	Description
29 SYNCEN3	<p>Synchronization Enable for n = 6</p> <p>Enables PWM synchronization of registers C(n)V and C(n+1)V.</p> <p>0 The PWM synchronization in this pair of channels is disabled. 1 The PWM synchronization in this pair of channels is enabled.</p>
28 DTEN3	<p>Deadtime Enable for n = 6</p> <p>Enables the deadtime insertion in the channels (n) and (n+1).</p> <p>This field is write protected. It can be written only when MODE[WPDIS] = 1.</p> <p>0 The deadtime insertion in this pair of channels is disabled. 1 The deadtime insertion in this pair of channels is enabled.</p>
27 DECAP3	<p>Dual Edge Capture Mode Captures for n = 6</p> <p>Enables the capture of the FTM counter value according to the channel (n) input event and the configuration of the dual edge capture bits.</p> <p>This field applies only when FTMEN = 1 and DECAPEN = 1.</p> <p>DECAP bit is cleared automatically by hardware if dual edge capture – one-shot mode is selected and when the capture of channel (n+1) event is made.</p> <p>0 The dual edge captures are inactive. 1 The dual edge captures are active.</p>
26 DECAPEN3	<p>Dual Edge Capture Mode Enable for n = 6</p> <p>Enables the dual edge capture mode in the channels (n) and (n+1). This bit reconfigures the function of MSnA, ELSnB:ELSnA and ELS(n+1)B:ELS(n+1)A bits in dual edge capture mode according to Table 36-7.</p> <p>This field applies only when FTMEN = 1.</p> <p>This field is write protected. It can be written only when MODE[WPDIS] = 1.</p> <p>0 The dual edge capture mode in this pair of channels is disabled. 1 The dual edge capture mode in this pair of channels is enabled.</p>
25 COMP3	<p>Complement of Channel (n) for n = 6</p> <p>Enables complementary mode for the combined channels. In complementary mode the channel (n+1) output is the inverse of the channel (n) output.</p> <p>This field is write protected. It can be written only when MODE[WPDIS] = 1.</p> <p>0 The channel (n+1) output is the same as the channel (n) output. 1 The channel (n+1) output is the complement of the channel (n) output.</p>
24 COMBINE3	<p>Combine Channels for n = 6</p> <p>Enables the combine feature for channels (n) and (n+1).</p> <p>This field is write protected. It can be written only when MODE[WPDIS] = 1.</p> <p>0 Channels (n) and (n+1) are independent. 1 Channels (n) and (n+1) are combined.</p>

Table continues on the next page...

FTMx_COMBINE field descriptions (continued)

Field	Description
23 Reserved	This read-only field is reserved and always has the value zero.
22 FAULTEN2	<p>Fault Control Enable for n = 4</p> <p>Enables the fault control in channels (n) and (n+1).</p> <p>This field is write protected. It can be written only when MODE[WPDIS] = 1.</p> <p>0 The fault control in this pair of channels is disabled. 1 The fault control in this pair of channels is enabled.</p>
21 SYNCEN2	<p>Synchronization Enable for n = 4</p> <p>Enables PWM synchronization of registers C(n)V and C(n+1)V.</p> <p>0 The PWM synchronization in this pair of channels is disabled. 1 The PWM synchronization in this pair of channels is enabled.</p>
20 DTEN2	<p>Deadtime Enable for n = 4</p> <p>Enables the deadtime insertion in the channels (n) and (n+1).</p> <p>This field is write protected. It can be written only when MODE[WPDIS] = 1.</p> <p>0 The deadtime insertion in this pair of channels is disabled. 1 The deadtime insertion in this pair of channels is enabled.</p>
19 DECAP2	<p>Dual Edge Capture Mode Captures for n = 4</p> <p>Enables the capture of the FTM counter value according to the channel (n) input event and the configuration of the dual edge capture bits.</p> <p>This field applies only when FTMEN = 1 and DECAPEN = 1.</p> <p>DECAP bit is cleared automatically by hardware if dual edge capture – one-shot mode is selected and when the capture of channel (n+1) event is made.</p> <p>0 The dual edge captures are inactive. 1 The dual edge captures are active.</p>
18 DECAPEN2	<p>Dual Edge Capture Mode Enable for n = 4</p> <p>Enables the dual edge capture mode in the channels (n) and (n+1). This bit reconfigures the function of MSnA, ELSnB:ELSnA and ELS(n+1)B:ELS(n+1)A bits in dual edge capture mode according to Table 36-7.</p> <p>This field applies only when FTMEN = 1.</p> <p>This field is write protected. It can be written only when MODE[WPDIS] = 1.</p> <p>0 The dual edge capture mode in this pair of channels is disabled. 1 The dual edge capture mode in this pair of channels is enabled.</p>
17 COMP2	<p>Complement of Channel (n) for n = 4</p> <p>Enables complementary mode for the combined channels. In complementary mode the channel (n+1) output is the inverse of the channel (n) output.</p> <p>This field is write protected. It can be written only when MODE[WPDIS] = 1.</p>

Table continues on the next page...

FTMx_COMBINE field descriptions (continued)

Field	Description
	<p>0 The channel (n+1) output is the same as the channel (n) output.</p> <p>1 The channel (n+1) output is the complement of the channel (n) output.</p>
16 COMBINE2	<p>Combine Channels for n = 4</p> <p>Enables the combine feature for channels (n) and (n+1).</p> <p>This field is write protected. It can be written only when MODE[WPDIS] = 1.</p> <p>0 Channels (n) and (n+1) are independent.</p> <p>1 Channels (n) and (n+1) are combined.</p>
15 Reserved	<p>This read-only field is reserved and always has the value zero.</p>
14 FAULTEN1	<p>Fault Control Enable for n = 2</p> <p>Enables the fault control in channels (n) and (n+1).</p> <p>This field is write protected. It can be written only when MODE[WPDIS] = 1.</p> <p>0 The fault control in this pair of channels is disabled.</p> <p>1 The fault control in this pair of channels is enabled.</p>
13 SYNCEN1	<p>Synchronization Enable for n = 2</p> <p>Enables PWM synchronization of registers C(n)V and C(n+1)V.</p> <p>0 The PWM synchronization in this pair of channels is disabled.</p> <p>1 The PWM synchronization in this pair of channels is enabled.</p>
12 DTEN1	<p>Deadtime Enable for n = 2</p> <p>Enables the deadtime insertion in the channels (n) and (n+1).</p> <p>This field is write protected. It can be written only when MODE[WPDIS] = 1.</p> <p>0 The deadtime insertion in this pair of channels is disabled.</p> <p>1 The deadtime insertion in this pair of channels is enabled.</p>
11 DECAP1	<p>Dual Edge Capture Mode Captures for n = 2</p> <p>Enables the capture of the FTM counter value according to the channel (n) input event and the configuration of the dual edge capture bits.</p> <p>This field applies only when FTMEN = 1 and DECAPEN = 1.</p> <p>DECAP bit is cleared automatically by hardware if dual edge capture – one-shot mode is selected and when the capture of channel (n+1) event is made.</p> <p>0 The dual edge captures are inactive.</p> <p>1 The dual edge captures are active.</p>
10 DECAPEN1	<p>Dual Edge Capture Mode Enable for n = 2</p> <p>Enables the dual edge capture mode in the channels (n) and (n+1). This bit reconfigures the function of MSnA, ELSnB:ELSnA and ELS(n+1)B:ELS(n+1)A bits in dual edge capture mode according to Table 36-7.</p> <p>This field applies only when FTMEN = 1.</p> <p>This field is write protected. It can be written only when MODE[WPDIS] = 1.</p>

Table continues on the next page...

FTMx_COMBINE field descriptions (continued)

Field	Description
	0 The dual edge capture mode in this pair of channels is disabled. 1 The dual edge capture mode in this pair of channels is enabled.
9 COMP1	Complement of Channel (n) for n = 2 Enables complementary mode for the combined channels. In complementary mode the channel (n+1) output is the inverse of the channel (n) output. This field is write protected. It can be written only when MODE[WPDIS] = 1. 0 The channel (n+1) output is the same as the channel (n) output. 1 The channel (n+1) output is the complement of the channel (n) output.
8 COMBINE1	Combine Channels for n = 2 Enables the combine feature for channels (n) and (n+1). This field is write protected. It can be written only when MODE[WPDIS] = 1. 0 Channels (n) and (n+1) are independent. 1 Channels (n) and (n+1) are combined.
7 Reserved	This read-only field is reserved and always has the value zero.
6 FAULTEN0	Fault Control Enable for n = 0 Enables the fault control in channels (n) and (n+1). This field is write protected. It can be written only when MODE[WPDIS] = 1. 0 The fault control in this pair of channels is disabled. 1 The fault control in this pair of channels is enabled.
5 SYNCEN0	Synchronization Enable for n = 0 Enables PWM synchronization of registers C(n)V and C(n+1)V. 0 The PWM synchronization in this pair of channels is disabled. 1 The PWM synchronization in this pair of channels is enabled.
4 DTEN0	Deadtime Enable for n = 0 Enables the deadtime insertion in the channels (n) and (n+1). This field is write protected. It can be written only when MODE[WPDIS] = 1. 0 The deadtime insertion in this pair of channels is disabled. 1 The deadtime insertion in this pair of channels is enabled.
3 DECAPO	Dual Edge Capture Mode Captures for n = 0 Enables the capture of the FTM counter value according to the channel (n) input event and the configuration of the dual edge capture bits. This field applies only when FTMEN = 1 and DECAPEN = 1. DECAP bit is cleared automatically by hardware if dual edge capture – one-shot mode is selected and when the capture of channel (n+1) event is made. 0 The dual edge captures are inactive. 1 The dual edge captures are active.

Table continues on the next page...

FTMx_COMBINE field descriptions (continued)

Field	Description
2 DECAPEN0	<p>Dual Edge Capture Mode Enable for n = 0</p> <p>Enables the dual edge capture mode in the channels (n) and (n+1). This bit reconfigures the function of MSnA, ELSnB:ELSnA and ELS(n+1)B:ELS(n+1)A bits in dual edge capture mode according to Table 36-7.</p> <p>This field applies only when FTMEN = 1.</p> <p>This field is write protected. It can be written only when MODE[WPDIS] = 1.</p> <p>0 The dual edge capture mode in this pair of channels is disabled. 1 The dual edge capture mode in this pair of channels is enabled.</p>
1 COMPO	<p>Complement of Channel (n) for n = 0</p> <p>Enables complementary mode for the combined channels. In complementary mode the channel (n+1) output is the inverse of the channel (n) output.</p> <p>This field is write protected. It can be written only when MODE[WPDIS] = 1.</p> <p>0 The channel (n+1) output is the same as the channel (n) output. 1 The channel (n+1) output is the complement of the channel (n) output.</p>
0 COMBINE0	<p>Combine Channels for n = 0</p> <p>Enables the combine feature for channels (n) and (n+1).</p> <p>This field is write protected. It can be written only when MODE[WPDIS] = 1.</p> <p>0 Channels (n) and (n+1) are independent. 1 Channels (n) and (n+1) are combined.</p>

36.3.15 Deadtime Insertion Control (FTMx_DEADTIME)

This register selects the deadtime prescaler factor and deadtime value. All FTM channels use this clock prescaler and this deadtime value for the deadtime insertion.

Addresses: FTM0_DEADTIME is 4003_8000h base + 68h offset = 4003_8068h

FTM1_DEADTIME is 4003_9000h base + 68h offset = 4003_9068h

FTM2_DEADTIME is 400B_8000h base + 68h offset = 400B_8068h

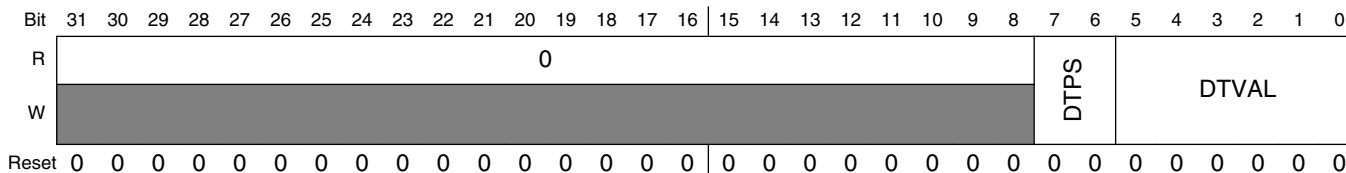

FTMx_DEADTIME field descriptions

Field	Description
31–8 Reserved	This read-only field is reserved and always has the value zero.

Table continues on the next page...

FTMx_DEADTIME field descriptions (continued)

Field	Description
7–6 DTPS	<p>Deadtime Prescaler Value</p> <p>Selects the division factor of the system clock. This prescaled clock is used by the deadtime counter.</p> <p>This field is write protected. It can be written only when MODE[WPDIS] = 1.</p> <p>0x Divide the system clock by 1. 10 Divide the system clock by 4. 11 Divide the system clock by 16.</p>
5–0 DTVAL	<p>Deadtime Value</p> <p>Selects the deadtime insertion value for the deadtime counter. The deadtime counter is clocked by a scaled version of the system clock. See the description of DTPS.</p> <p>Deadtime insert value = (DTPS × DTVAL).</p> <p>DTVAL selects the number of deadtime counts inserted as follows:</p> <p>When DTVAL is 0, no counts are inserted. When DTVAL is 1, 1 count is inserted. When DTVAL is 2, 2 counts are inserted.</p> <p>This pattern continues up to a possible 63 counts.</p> <p>This field is write protected. It can be written only when MODE[WPDIS] = 1.</p>

36.3.16 FTM External Trigger (FTMx_EXTTRIG)

This register indicates when a channel trigger was generated, enables the generation of a trigger when the FTM counter is equal to its initial value, and selects which channels are used in the generation of the channel triggers. Several channels can be selected to generate multiple triggers in one PWM period.

Channels 6 and 7 are not used to generate channel triggers.

memory Map and Register Definition

Addresses: FTM0_EXTTRIG is 4003_8000h base + 6Ch offset = 4003_806Ch

FTM1_EXTTRIG is 4003_9000h base + 6Ch offset = 4003_906Ch

FTM2_EXTTRIG is 400B_8000h base + 6Ch offset = 400B_806Ch

Bit	31	30	29	28	27	26	25	24	23	22	21	20	19	18	17	16
R	Reserved[bit 8]															
W																
Reset	0	0	0	0	0	0	0	0	0	0	0	0	0	0	0	0
Bit	15	14	13	12	11	10	9	8	7	6	5	4	3	2	1	0
R	Reserved[7:0]								TRIGF	INITRIGEN	CH1TRIG	CH0TRIG	CH5TRIG	CH4TRIG	CH3TRIG	CH2TRIG
W																
Reset	0	0	0	0	0	0	0	0	0	0	0	0	0	0	0	0

FTMx_EXTTRIG field descriptions

Field	Description
31–8 Reserved	This field is reserved.
7 TRIGF	<p>Channel Trigger Flag</p> <p>Set by hardware when a channel trigger is generated. Clear TRIGF by reading EXTTRIG while TRIGF is set and then writing a 0 to TRIGF. Writing a 1 to TRIGF has no effect.</p> <p>If another channel trigger is generated before the clearing sequence is completed, the sequence is reset so TRIGF remains set after the clear sequence is completed for the earlier TRIGF.</p> <p>0 No channel trigger was generated. 1 A channel trigger was generated.</p>
6 INITRIGEN	<p>Initialization Trigger Enable</p> <p>Enables the generation of the trigger when the FTM counter is equal to the CNTIN register.</p> <p>0 The generation of initialization trigger is disabled. 1 The generation of initialization trigger is enabled.</p>
5 CH1TRIG	<p>Channel 1 Trigger Enable</p> <p>Enable the generation of the channel trigger when the FTM counter is equal to the CnV register.</p> <p>0 The generation of the channel trigger is disabled. 1 The generation of the channel trigger is enabled.</p>
4 CH0TRIG	<p>Channel 0 Trigger Enable</p> <p>Enable the generation of the channel trigger when the FTM counter is equal to the CnV register.</p> <p>0 The generation of the channel trigger is disabled. 1 The generation of the channel trigger is enabled.</p>
3 CH5TRIG	<p>Channel 5 Trigger Enable</p>

Table continues on the next page...

FTMx_EXTTRIG field descriptions (continued)

Field	Description
	Enable the generation of the channel trigger when the FTM counter is equal to the CnV register. 0 The generation of the channel trigger is disabled. 1 The generation of the channel trigger is enabled.
2 CH4TRIG	Channel 4 Trigger Enable Enable the generation of the channel trigger when the FTM counter is equal to the CnV register. 0 The generation of the channel trigger is disabled. 1 The generation of the channel trigger is enabled.
1 CH3TRIG	Channel 3 Trigger Enable Enable the generation of the channel trigger when the FTM counter is equal to the CnV register. 0 The generation of the channel trigger is disabled. 1 The generation of the channel trigger is enabled.
0 CH2TRIG	Channel 2 Trigger Enable Enable the generation of the channel trigger when the FTM counter is equal to the CnV register. 0 The generation of the channel trigger is disabled. 1 The generation of the channel trigger is enabled.

36.3.17 Channels Polarity (FTMx_POL)

This register defines the output polarity of the FTM channels.

NOTE

The safe value that is driven in a channel output when the fault control is enabled and a fault condition is detected is the inactive state of the channel. That is, the safe value of a channel is the value of its POL bit.

Addresses: FTM0_POL is 4003_8000h base + 70h offset = 4003_8070h
 FTM1_POL is 4003_9000h base + 70h offset = 4003_9070h
 FTM2_POL is 400B_8000h base + 70h offset = 400B_8070h

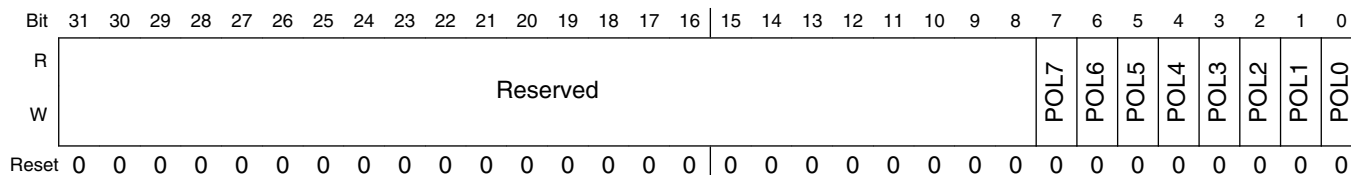

FTMx_POL field descriptions

Field	Description
31–8 Reserved	This field is reserved.
7 POL7	<p>Channel 7 Polarity</p> <p>Defines the polarity of the channel output.</p> <p>This field is write protected. It can be written only when MODE[WPDIS] = 1.</p> <p>0 The channel polarity is active high. 1 The channel polarity is active low.</p>
6 POL6	<p>Channel 6 Polarity</p> <p>Defines the polarity of the channel output.</p> <p>This field is write protected. It can be written only when MODE[WPDIS] = 1.</p> <p>0 The channel polarity is active high. 1 The channel polarity is active low.</p>
5 POL5	<p>Channel 5 Polarity</p> <p>Defines the polarity of the channel output.</p> <p>This field is write protected. It can be written only when MODE[WPDIS] = 1.</p> <p>0 The channel polarity is active high. 1 The channel polarity is active low.</p>
4 POL4	<p>Channel 4 Polarity</p> <p>Defines the polarity of the channel output.</p> <p>This field is write protected. It can be written only when MODE[WPDIS] = 1.</p> <p>0 The channel polarity is active high. 1 The channel polarity is active low.</p>
3 POL3	<p>Channel 3 Polarity</p> <p>Defines the polarity of the channel output.</p> <p>This field is write protected. It can be written only when MODE[WPDIS] = 1.</p> <p>0 The channel polarity is active high. 1 The channel polarity is active low.</p>
2 POL2	<p>Channel 2 Polarity</p> <p>Defines the polarity of the channel output.</p> <p>This field is write protected. It can be written only when MODE[WPDIS] = 1.</p> <p>0 The channel polarity is active high. 1 The channel polarity is active low.</p>
1 POL1	<p>Channel 1 Polarity</p> <p>Defines the polarity of the channel output.</p> <p>This field is write protected. It can be written only when MODE[WPDIS] = 1.</p>

Table continues on the next page...

FTMx_POL field descriptions (continued)

Field	Description
	0 The channel polarity is active high. 1 The channel polarity is active low.
0 POL0	Channel 0 Polarity Defines the polarity of the channel output. This field is write protected. It can be written only when MODE[WPDIS] = 1. 0 The channel polarity is active high. 1 The channel polarity is active low.

36.3.18 Fault Mode Status (FTMx_FMS)

This register contains the fault detection flags, write protection enable bit, and the logic OR of the enabled fault inputs.

Addresses: FTM0_FMS is 4003_8000h base + 74h offset = 4003_8074h

FTM1_FMS is 4003_9000h base + 74h offset = 4003_9074h

FTM2_FMS is 400B_8000h base + 74h offset = 400B_8074h

Bit	31	30	29	28	27	26	25	24	23	22	21	20	19	18	17	16
R	0															
W	[Shaded]															
Reset	0	0	0	0	0	0	0	0	0	0	0	0	0	0	0	0
Bit	15	14	13	12	11	10	9	8	7	6	5	4	3	2	1	0
R	0								FAULTF	WPEN	FAULTIN	0	FAULTF3	FAULTF2	FAULTF1	FAULTF0
W	[Shaded]								0	[Shaded]	[Shaded]	[Shaded]	0	0	0	0
Reset	0	0	0	0	0	0	0	0	0	0	0	0	0	0	0	0

FTMx_FMS field descriptions

Field	Description
31–8 Reserved	This read-only field is reserved and always has the value zero.

Table continues on the next page...

FTMx_FMS field descriptions (continued)

Field	Description
7 FAULTF	<p>Fault Detection Flag</p> <p>Represents the logic OR of the individual FAULTF_j bits (where j = 3, 2, 1, 0). Clear FAULTF by reading the FMS register while FAULTF is set and then writing a 0 to FAULTF while there is no existing fault condition at the enabled fault inputs. Writing a 1 to FAULTF has no effect.</p> <p>If another fault condition is detected in an enabled fault input before the clearing sequence is completed, the sequence is reset so FAULTF remains set after the clearing sequence is completed for the earlier fault condition. FAULTF is also cleared when FAULTF_j bits are cleared individually.</p> <p>0 No fault condition was detected. 1 A fault condition was detected.</p>
6 WPEN	<p>Write Protection Enable</p> <p>The WPEN bit is the negation of the WPDIS bit. WPEN is set when 1 is written to it. WPEN is cleared when WPEN bit is read as a 1 and then 1 is written to WPDIS. Writing 0 to WPEN has no effect.</p> <p>0 Write protection is disabled. Write protected bits can be written. 1 Write protection is enabled. Write protected bits cannot be written.</p>
5 FAULTIN	<p>Fault Inputs</p> <p>Represents the logic OR of the enabled fault inputs after their filter (if their filter is enabled) when fault control is enabled.</p> <p>0 The logic OR of the enabled fault inputs is 0. 1 The logic OR of the enabled fault inputs is 1.</p>
4 Reserved	<p>This read-only field is reserved and always has the value zero.</p>
3 FAULTF3	<p>Fault Detection Flag 3</p> <p>Set by hardware when fault control is enabled, the corresponding fault input is enabled and a fault condition is detected at the fault input.</p> <p>Clear FAULTF3 by reading the FMS register while FAULTF3 is set and then writing a 0 to FAULTF3 while there is no existing fault condition at the the corresponding fault input. Writing a 1 to FAULTF3 has no effect. FAULTF3 bit is also cleared when FAULTF bit is cleared.</p> <p>If another fault condition is detected at the corresponding fault input before the clearing sequence is completed, the sequence is reset so FAULTF3 remains set after the clearing sequence is completed for the earlier fault condition.</p> <p>0 No fault condition was detected at the fault input. 1 A fault condition was detected at the fault input.</p>
2 FAULTF2	<p>Fault Detection Flag 2</p> <p>Set by hardware when fault control is enabled, the corresponding fault input is enabled and a fault condition is detected at the fault input.</p> <p>Clear FAULTF2 by reading the FMS register while FAULTF2 is set and then writing a 0 to FAULTF2 while there is no existing fault condition at the the corresponding fault input. Writing a 1 to FAULTF2 has no effect. FAULTF2 bit is also cleared when FAULTF bit is cleared.</p> <p>If another fault condition is detected at the corresponding fault input before the clearing sequence is completed, the sequence is reset so FAULTF2 remains set after the clearing sequence is completed for the earlier fault condition.</p>

Table continues on the next page...

FTMx_FMS field descriptions (continued)

Field	Description
	0 No fault condition was detected at the fault input. 1 A fault condition was detected at the fault input.
1 FAULTF1	Fault Detection Flag 1 Set by hardware when fault control is enabled, the corresponding fault input is enabled and a fault condition is detected at the fault input. Clear FAULTF1 by reading the FMS register while FAULTF1 is set and then writing a 0 to FAULTF1 while there is no existing fault condition at the the corresponding fault input. Writing a 1 to FAULTF1 has no effect. FAULTF1 bit is also cleared when FAULTF bit is cleared. If another fault condition is detected at the corresponding fault input before the clearing sequence is completed, the sequence is reset so FAULTF1 remains set after the clearing sequence is completed for the earlier fault condition. 0 No fault condition was detected at the fault input. 1 A fault condition was detected at the fault input.
0 FAULTF0	Fault Detection Flag 0 Set by hardware when fault control is enabled, the corresponding fault input is enabled and a fault condition is detected at the fault input. Clear FAULTF0 by reading the FMS register while FAULTF0 is set and then writing a 0 to FAULTF0 while there is no existing fault condition at the the corresponding fault input. Writing a 1 to FAULTF0 has no effect. FAULTF0 bit is also cleared when FAULTF bit is cleared. If another fault condition is detected at the corresponding fault input before the clearing sequence is completed, the sequence is reset so FAULTF0 remains set after the clearing sequence is completed for the earlier fault condition. 0 No fault condition was detected at the fault input. 1 A fault condition was detected at the fault input.

36.3.19 Input Capture Filter Control (FTMx_FILTER)

This register selects the filter value for the inputs of channels.

Channels 4, 5, 6 and 7 do not have an input filter.

NOTE

Writing to the FILTER register has immediate effect and must be done only when the channels 0, 1, 2, and 3 are not in input modes. Failure to do this could result in a missing valid signal.

memory Map and Register Definition

Addresses: FTM0_FILTER is 4003_8000h base + 78h offset = 4003_8078h

FTM1_FILTER is 4003_9000h base + 78h offset = 4003_9078h

FTM2_FILTER is 400B_8000h base + 78h offset = 400B_8078h

Bit	31	30	29	28	27	26	25	24	23	22	21	20	19	18	17	16	15	14	13	12	11	10	9	8	7	6	5	4	3	2	1	0
R	Reserved																CH3FVAL				CH2FVAL				CH1FVAL				CH0FVAL			
W																																
Reset	0 0 0 0 0 0 0 0 0 0 0 0 0 0 0 0																0 0 0 0				0 0 0 0				0 0 0 0				0 0 0 0			

FTMx_FILTER field descriptions

Field	Description
31–16 Reserved	This field is reserved.
15–12 CH3FVAL	Channel 3 Input Filter Selects the filter value for the channel input. The filter is disabled when the value is zero.
11–8 CH2FVAL	Channel 2 Input Filter Selects the filter value for the channel input. The filter is disabled when the value is zero.
7–4 CH1FVAL	Channel 1 Input Filter Selects the filter value for the channel input. The filter is disabled when the value is zero.
3–0 CH0FVAL	Channel 0 Input Filter Selects the filter value for the channel input. The filter is disabled when the value is zero.

36.3.20 Fault Control (FTMx_FLTCTRL)

This register selects the filter value for the fault inputs, enables the fault inputs and the fault inputs filter.

Addresses: FTM0_FLTCTRL is 4003_8000h base + 7Ch offset = 4003_807Ch

FTM1_FLTCTRL is 4003_9000h base + 7Ch offset = 4003_907Ch

FTM2_FLTCTRL is 400B_8000h base + 7Ch offset = 400B_807Ch

Bit	31	30	29	28	27	26	25	24	23	22	21	20	19	18	17	16
R	0															
W	[Greyed out]															
Reset	0	0	0	0	0	0	0	0	0	0	0	0	0	0	0	0
Bit	15	14	13	12	11	10	9	8	7	6	5	4	3	2	1	0
R	0				FFVAL				FELTR3EN	FELTR2EN	FELTR1EN	FELTR0EN	FAULT3EN	FAULT2EN	FAULT1EN	FAULT0EN
W	[Greyed out]				[Greyed out]				[Greyed out]	[Greyed out]	[Greyed out]	[Greyed out]	[Greyed out]	[Greyed out]	[Greyed out]	[Greyed out]
Reset	0	0	0	0	0	0	0	0	0	0	0	0	0	0	0	0

FTMx_FLTCTRL field descriptions

Field	Description
31–12 Reserved	This read-only field is reserved and always has the value zero.
11–8 FFVAL	Fault Input Filter Selects the filter value for the fault inputs. The fault filter is disabled when the value is zero. NOTE: Writing to this field has immediate effect and must be done only when the fault control or all fault inputs are disabled. Failure to do this could result in a missing fault detection.
7 FFLTR3EN	Fault Input 3 Filter Enable Enables the filter for the fault input. This field is write protected. It can be written only when MODE[WPDIS] = 1. 0 Fault input filter is disabled. 1 Fault input filter is enabled.
6 FFLTR2EN	Fault Input 2 Filter Enable Enables the filter for the fault input. This field is write protected. It can be written only when MODE[WPDIS] = 1. 0 Fault input filter is disabled. 1 Fault input filter is enabled.

Table continues on the next page...

FTMx_FLTCTRL field descriptions (continued)

Field	Description
5 FFLTR1EN	<p>Fault Input 1 Filter Enable</p> <p>Enables the filter for the fault input.</p> <p>This field is write protected. It can be written only when MODE[WPDIS] = 1.</p> <p>0 Fault input filter is disabled. 1 Fault input filter is enabled.</p>
4 FFLTR0EN	<p>Fault Input 0 Filter Enable</p> <p>Enables the filter for the fault input.</p> <p>This field is write protected. It can be written only when MODE[WPDIS] = 1.</p> <p>0 Fault input filter is disabled. 1 Fault input filter is enabled.</p>
3 FAULT3EN	<p>Fault Input 3 Enable</p> <p>Enables the fault input.</p> <p>This field is write protected. It can be written only when MODE[WPDIS] = 1.</p> <p>0 Fault input is disabled. 1 Fault input is enabled.</p>
2 FAULT2EN	<p>Fault Input 2 Enable</p> <p>Enables the fault input.</p> <p>This field is write protected. It can be written only when MODE[WPDIS] = 1.</p> <p>0 Fault input is disabled. 1 Fault input is enabled.</p>
1 FAULT1EN	<p>Fault Input 1 Enable</p> <p>Enables the fault input.</p> <p>This field is write protected. It can be written only when MODE[WPDIS] = 1.</p> <p>0 Fault input is disabled. 1 Fault input is enabled.</p>
0 FAULT0EN	<p>Fault Input 0 Enable</p> <p>Enables the fault input.</p> <p>This field is write protected. It can be written only when MODE[WPDIS] = 1.</p> <p>0 Fault input is disabled. 1 Fault input is enabled.</p>

36.3.21 Quadrature Decoder Control and Status (FTMx_QDCTRL)

This register has the control and status bits for the quadrature decoder mode.

Addresses: FTM0_QDCTRL is 4003_8000h base + 80h offset = 4003_8080h

FTM1_QDCTRL is 4003_9000h base + 80h offset = 4003_9080h

FTM2_QDCTRL is 400B_8000h base + 80h offset = 400B_8080h

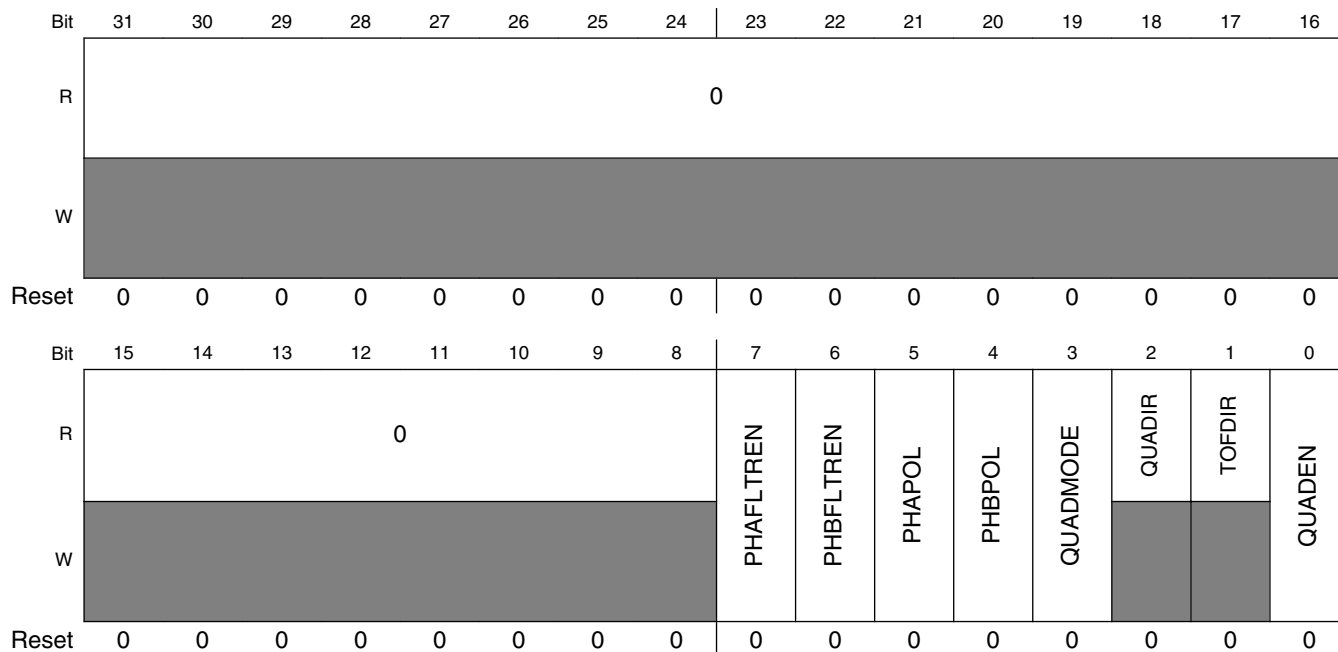

FTMx_QDCTRL field descriptions

Field	Description
31–8 Reserved	This read-only field is reserved and always has the value zero.
7 PHAFLTREN	Phase A Input Filter Enable Enables the filter for the quadrature decoder phase A input. The filter value for the phase A input is defined by the CH0FVAL field of FILTER. The phase A filter is also disabled when CH0FVAL is zero. 0 Phase A input filter is disabled. 1 Phase A input filter is enabled.
6 PHBFLTREN	Phase B Input Filter Enable Enables the filter for the quadrature decoder phase B input. The filter value for the phase B input is defined by the CH1FVAL field of FILTER. The phase B filter is also disabled when CH1FVAL is zero. 0 Phase B input filter is disabled. 1 Phase B input filter is enabled.
5 PHAPOL	Phase A Input Polarity Selects the polarity for the quadrature decoder phase A input.

Table continues on the next page...

FTMx_QDCTRL field descriptions (continued)

Field	Description
	<p>0 Normal polarity. Phase A input signal is not inverted before identifying the rising and falling edges of this signal.</p> <p>1 Inverted polarity. Phase A input signal is inverted before identifying the rising and falling edges of this signal.</p>
4 PHBPOL	<p>Phase B Input Polarity</p> <p>Selects the polarity for the quadrature decoder phase B input.</p> <p>0 Normal polarity. Phase B input signal is not inverted before identifying the rising and falling edges of this signal.</p> <p>1 Inverted polarity. Phase B input signal is inverted before identifying the rising and falling edges of this signal.</p>
3 QUADMODE	<p>Quadrature Decoder Mode</p> <p>Selects the encoding mode used in the quadrature decoder mode.</p> <p>0 Phase A and phase B encoding mode.</p> <p>1 Count and direction encoding mode.</p>
2 QUADIR	<p>FTM Counter Direction in Quadrature Decoder Mode</p> <p>Indicates the counting direction.</p> <p>0 Counting direction is decreasing (FTM counter decrement).</p> <p>1 Counting direction is increasing (FTM counter increment).</p>
1 TOFDIR	<p>Timer Overflow Direction in Quadrature Decoder Mode</p> <p>Indicates if the TOF bit was set on the top or the bottom of counting.</p> <p>0 TOF bit was set on the bottom of counting. There was an FTM counter decrement and FTM counter changes from its minimum value (CNTIN register) to its maximum value (MOD register).</p> <p>1 TOF bit was set on the top of counting. There was an FTM counter increment and FTM counter changes from its maximum value (MOD register) to its minimum value (CNTIN register).</p>
0 QUADEN	<p>Quadrature Decoder Mode Enable</p> <p>Enables the quadrature decoder mode. In this mode, the phase A and B input signals control the FTM counter direction. The quadrature decoder mode has precedence over the other modes. (See Table 36-7.)</p> <p>This field is write protected. It can be written only when MODE[WPDIS] = 1.</p> <p>0 Quadrature decoder mode is disabled.</p> <p>1 Quadrature decoder mode is enabled.</p>

36.3.22 Configuration (FTMx_CONF)

This register selects the number of times that the FTM counter overflow should occur before the TOF bit to be set, the FTM behavior in BDM modes, the use of an external global time base, and the global time base signal generation.

Addresses: FTM0_CONF is 4003_8000h base + 84h offset = 4003_8084h

FTM1_CONF is 4003_9000h base + 84h offset = 4003_9084h

FTM2_CONF is 400B_8000h base + 84h offset = 400B_8084h

Bit	31	30	29	28	27	26	25	24	23	22	21	20	19	18	17	16
R	0															
W	[Shaded]															
Reset	0	0	0	0	0	0	0	0	0	0	0	0	0	0	0	0
Bit	15	14	13	12	11	10	9	8	7	6	5	4	3	2	1	0
R	0					GTBEOUT	GTBEEN	0	BDMMODE	0	NUMTOF					
W	[Shaded]					[Shaded]	[Shaded]	[Shaded]	[Shaded]	[Shaded]	[Shaded]					
Reset	0	0	0	0	0	0	0	0	0	0	0	0	0	0	0	0

FTMx_CONF field descriptions

Field	Description
31–11 Reserved	This read-only field is reserved and always has the value zero.
10 GTBEOUT	Global time base output Enables the global time base signal generation to other FTMs. 0 A global time base signal generation is disabled. 1 A global time base signal generation is enabled.
9 GTBEEN	Global time base enable Configures the FTM to use an external global time base signal that is generated by another FTM. 0 Use of an external global time base is disabled. 1 Use of an external global time base is enabled.
8 Reserved	This read-only field is reserved and always has the value zero.
7–6 BDMMODE	BDM Mode Selects the FTM behavior in BDM mode. See BDM Mode .
5 Reserved	This read-only field is reserved and always has the value zero.

Table continues on the next page...

FTMx_CONF field descriptions (continued)

Field	Description
4–0 NUMTOF	<p>TOF Frequency</p> <p>Selects the ratio between the number of counter overflows to the number of times the TOF bit is set.</p> <p>NUMTOF = 0: The TOF bit is set for each counter overflow.</p> <p>NUMTOF = 1: The TOF bit is set for the first counter overflow but not for the next overflow.</p> <p>NUMTOF = 2: The TOF bit is set for the first counter overflow but not for the next 2 overflows.</p> <p>NUMTOF = 3: The TOF bit is set for the first counter overflow but not for the next 3 overflows.</p> <p>This pattern continues up to a maximum of 31.</p>

36.3.23 FTM Fault Input Polarity (FTMx_FLTPOL)

This register defines the fault inputs polarity.

Addresses: FTM0_FLTPOL is 4003_8000h base + 88h offset = 4003_8088h

FTM1_FLTPOL is 4003_9000h base + 88h offset = 4003_9088h

FTM2_FLTPOL is 400B_8000h base + 88h offset = 400B_8088h

Bit	31	30	29	28	27	26	25	24	23	22	21	20	19	18	17	16
R	0															
W	[Shaded]															
Reset	0	0	0	0	0	0	0	0	0	0	0	0	0	0	0	0
Bit	15	14	13	12	11	10	9	8	7	6	5	4	3	2	1	0
R	0												FLT3POL	FLT2POL	FLT1POL	FLT0POL
W	[Shaded]												FLT3POL	FLT2POL	FLT1POL	FLT0POL
Reset	0	0	0	0	0	0	0	0	0	0	0	0	0	0	0	0

FTMx_FLTPOL field descriptions

Field	Description
31–4 Reserved	This read-only field is reserved and always has the value zero.
3 FLT3POL	<p>Fault Input 3 Polarity</p> <p>Defines the polarity of the fault input.</p> <p>This field is write protected. It can be written only when MODE[WPDIS] = 1.</p> <p>0 The fault input polarity is active high. A one at the fault input indicates a fault.</p> <p>1 The fault input polarity is active low. A zero at the fault input indicates a fault.</p>

Table continues on the next page...

FTMx_FLTPOL field descriptions (continued)

Field	Description
2 FLT2POL	<p data-bbox="350 250 574 275">Fault Input 2 Polarity</p> <p data-bbox="350 298 740 323">Defines the polarity of the fault input.</p> <p data-bbox="350 346 1146 370">This field is write protected. It can be written only when MODE[WPDIS] = 1.</p> <p data-bbox="350 393 1203 418">0 The fault input polarity is active high. A one at the fault input indicates a fault.</p> <p data-bbox="350 430 1203 455">1 The fault input polarity is active low. A zero at the fault input indicates a fault.</p>
1 FLT1POL	<p data-bbox="350 484 574 509">Fault Input 1 Polarity</p> <p data-bbox="350 532 740 557">Defines the polarity of the fault input.</p> <p data-bbox="350 580 1146 605">This field is write protected. It can be written only when MODE[WPDIS] = 1.</p> <p data-bbox="350 627 1203 652">0 The fault input polarity is active high. A one at the fault input indicates a fault.</p> <p data-bbox="350 665 1203 689">1 The fault input polarity is active low. A zero at the fault input indicates a fault.</p>
0 FLT0POL	<p data-bbox="350 718 574 743">Fault Input 0 Polarity</p> <p data-bbox="350 766 740 791">Defines the polarity of the fault input.</p> <p data-bbox="350 814 1146 839">This field is write protected. It can be written only when MODE[WPDIS] = 1.</p> <p data-bbox="350 861 1203 886">0 The fault input polarity is active high. A one at the fault input indicates a fault.</p> <p data-bbox="350 899 1203 924">1 The fault input polarity is active low. A zero at the fault input indicates a fault.</p>

36.3.24 Synchronization Configuration (FTM_x_SYNCONF)

This register selects the PWM synchronization configuration, SWOCTRL, INVCTRL and CNTIN registers synchronization, if FTM clears the TRIG_j bit (where j = 0, 1, 2) when the hardware trigger j is detected.

Addresses: FTM0_SYNCONF is 4003_8000h base + 8Ch offset = 4003_808Ch

FTM1_SYNCONF is 4003_9000h base + 8Ch offset = 4003_908Ch

FTM2_SYNCONF is 400B_8000h base + 8Ch offset = 400B_808Ch

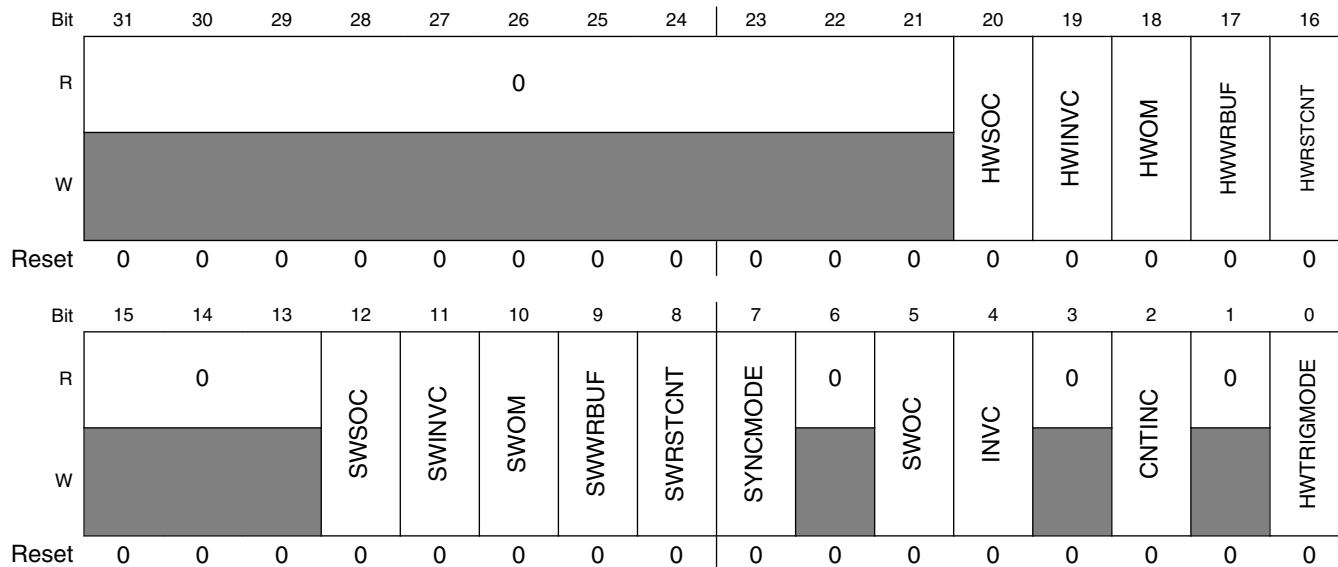

FTM_x_SYNCONF field descriptions

Field	Description
31–21 Reserved	This read-only field is reserved and always has the value zero.
20 HWSOC	Software output control synchronization is activated by a hardware trigger. 0 A hardware trigger does not activate the SWOCTRL register synchronization. 1 A hardware trigger activates the SWOCTRL register synchronization.
19 HWINVC	Inverting control synchronization is activated by a hardware trigger. 0 A hardware trigger does not activate the INVCTRL register synchronization. 1 A hardware trigger activates the INVCTRL register synchronization.
18 HWOM	Output mask synchronization is activated by a hardware trigger. 0 A hardware trigger does not activate the OUTMASK register synchronization. 1 A hardware trigger activates the OUTMASK register synchronization.
17 HWRBUBUF	MOD, CNTIN, and CV registers synchronization is activated by a hardware trigger. 0 A hardware trigger does not activate MOD, CNTIN, and CV registers synchronization. 1 A hardware trigger activates MOD, CNTIN, and CV registers synchronization.

Table continues on the next page...

FTMx_SYNCONF field descriptions (continued)

Field	Description
16 HWRSTCNT	FTM counter synchronization is activated by a hardware trigger. 0 A hardware trigger does not activate the FTM counter synchronization. 1 A hardware trigger activates the FTM counter synchronization.
15–13 Reserved	This read-only field is reserved and always has the value zero.
12 SWSOC	Software output control synchronization is activated by the software trigger. 0 The software trigger does not activate the SWOCTRL register synchronization. 1 The software trigger activates the SWOCTRL register synchronization.
11 SWINVC	Inverting control synchronization is activated by the software trigger. 0 The software trigger does not activate the INVCTRL register synchronization. 1 The software trigger activates the INVCTRL register synchronization.
10 SWOM	Output mask synchronization is activated by the software trigger. 0 The software trigger does not activate the OUTMASK register synchronization. 1 The software trigger activates the OUTMASK register synchronization.
9 SWWRBUF	MOD, CNTIN, and CV registers synchronization is activated by the software trigger. 0 The software trigger does not activate MOD, CNTIN, and CV registers synchronization. 1 The software trigger activates MOD, CNTIN, and CV registers synchronization.
8 SWRSTCNT	FTM counter synchronization is activated by the software trigger. 0 The software trigger does not activate the FTM counter synchronization. 1 The software trigger activates the FTM counter synchronization.
7 SYNCMODE	Synchronization Mode Selects the PWM synchronization mode. 0 Legacy PWM synchronization is selected. 1 Enhanced PWM synchronization is selected.
6 Reserved	This read-only field is reserved and always has the value zero.
5 SWOC	SWOCTRL register synchronization 0 SWOCTRL register is updated with its buffer value at all rising edges of system clock. 1 SWOCTRL register is updated with its buffer value by the PWM synchronization.
4 INVC	INVCTRL register synchronization 0 INVCTRL register is updated with its buffer value at all rising edges of system clock. 1 INVCTRL register is updated with its buffer value by the PWM synchronization.
3 Reserved	This read-only field is reserved and always has the value zero.
2 CNTINC	CNTIN register synchronization

Table continues on the next page...

FTMx_SYNCONF field descriptions (continued)

Field	Description
	0 CNTIN register is updated with its buffer value at all rising edges of system clock. 1 CNTIN register is updated with its buffer value by the PWM synchronization.
1 Reserved	This read-only field is reserved and always has the value zero.
0 HWTRIGMODE	Hardware Trigger Mode 0 FTM clears the TRIGj bit when the hardware trigger j is detected. 1 FTM does not clear the TRIGj bit when the hardware trigger j is detected.

36.3.25 FTM Inverting Control (FTMx_INVCTRL)

This register controls when the channel (n) output becomes the channel (n+1) output, and channel (n+1) output becomes the channel (n) output. Each INVmEN bit enables the inverting operation for the corresponding pair channels m.

This register has a write buffer. The INVmEN bit is updated by the INVCTRL register synchronization.

Addresses: FTM0_INVCTRL is 4003_8000h base + 90h offset = 4003_8090h

FTM1_INVCTRL is 4003_9000h base + 90h offset = 4003_9090h

FTM2_INVCTRL is 400B_8000h base + 90h offset = 400B_8090h

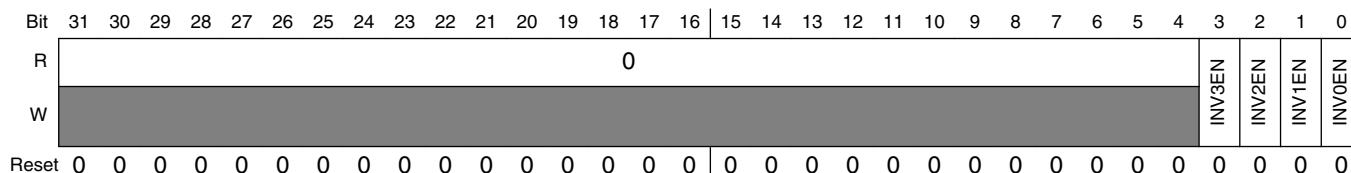

FTMx_INVCTRL field descriptions

Field	Description
31–4 Reserved	This read-only field is reserved and always has the value zero.
3 INV3EN	Pair Channels 3 Inverting Enable 0 Inverting is disabled. 1 Inverting is enabled.
2 INV2EN	Pair Channels 2 Inverting Enable 0 Inverting is disabled. 1 Inverting is enabled.
1 INV1EN	Pair Channels 1 Inverting Enable

Table continues on the next page...

FTMx_INVCTRL field descriptions (continued)

Field	Description
	0 Inverting is disabled. 1 Inverting is enabled.
0 INVOEN	Pair Channels 0 Inverting Enable 0 Inverting is disabled. 1 Inverting is enabled.

36.3.26 FTM Software Output Control (FTMx_SWOCTRL)

This register enables software control of channel (n) output and defines the value forced to the channel (n) output:

- The CHnOC bits enable the control of the corresponding channel (n) output by software.
- The CHnOCV bits select the value that is forced at the corresponding channel (n) output.

This register has a write buffer. The fields are updated by the SWOCTRL register synchronization.

Addresses: FTM0_SWOCTRL is 4003_8000h base + 94h offset = 4003_8094h

FTM1_SWOCTRL is 4003_9000h base + 94h offset = 4003_9094h

FTM2_SWOCTRL is 400B_8000h base + 94h offset = 400B_8094h

Bit	31	30	29	28	27	26	25	24	23	22	21	20	19	18	17	16
R	0															
W																
Reset	0	0	0	0	0	0	0	0	0	0	0	0	0	0	0	0
Bit	15	14	13	12	11	10	9	8	7	6	5	4	3	2	1	0
R	CH7OCV	CH6OCV	CH5OCV	CH4OCV	CH3OCV	CH2OCV	CH1OCV	CH0OCV	CH7OC	CH6OC	CH5OC	CH4OC	CH3OC	CH2OC	CH1OC	CH0OC
W	CH7OCV	CH6OCV	CH5OCV	CH4OCV	CH3OCV	CH2OCV	CH1OCV	CH0OCV	CH7OC	CH6OC	CH5OC	CH4OC	CH3OC	CH2OC	CH1OC	CH0OC
Reset	0	0	0	0	0	0	0	0	0	0	0	0	0	0	0	0

FTMx_SWOCTRL field descriptions

Field	Description
31–16 Reserved	This read-only field is reserved and always has the value zero.

Table continues on the next page...

FTMx_SWOCTRL field descriptions (continued)

Field	Description
15 CH7OCV	Channel 7 Software Output Control Value 0 The software output control forces 0 to the channel output. 1 The software output control forces 1 to the channel output.
14 CH6OCV	Channel 6 Software Output Control Value 0 The software output control forces 0 to the channel output. 1 The software output control forces 1 to the channel output.
13 CH5OCV	Channel 5 Software Output Control Value 0 The software output control forces 0 to the channel output. 1 The software output control forces 1 to the channel output.
12 CH4OCV	Channel 4 Software Output Control Value 0 The software output control forces 0 to the channel output. 1 The software output control forces 1 to the channel output.
11 CH3OCV	Channel 3 Software Output Control Value 0 The software output control forces 0 to the channel output. 1 The software output control forces 1 to the channel output.
10 CH2OCV	Channel 2 Software Output Control Value 0 The software output control forces 0 to the channel output. 1 The software output control forces 1 to the channel output.
9 CH1OCV	Channel 1 Software Output Control Value 0 The software output control forces 0 to the channel output. 1 The software output control forces 1 to the channel output.
8 CH0OCV	Channel 0 Software Output Control Value 0 The software output control forces 0 to the channel output. 1 The software output control forces 1 to the channel output.
7 CH7OC	Channel 7 Software Output Control Enable 0 The channel output is not affected by software output control. 1 The channel output is affected by software output control.
6 CH6OC	Channel 6 Software Output Control Enable 0 The channel output is not affected by software output control. 1 The channel output is affected by software output control.
5 CH5OC	Channel 5 Software Output Control Enable 0 The channel output is not affected by software output control. 1 The channel output is affected by software output control.
4 CH4OC	Channel 4 Software Output Control Enable

Table continues on the next page...

FTMx_SWOCTRL field descriptions (continued)

Field	Description
	0 The channel output is not affected by software output control. 1 The channel output is affected by software output control.
3 CH3OC	Channel 3 Software Output Control Enable 0 The channel output is not affected by software output control. 1 The channel output is affected by software output control.
2 CH2OC	Channel 2 Software Output Control Enable 0 The channel output is not affected by software output control. 1 The channel output is affected by software output control.
1 CH1OC	Channel 1 Software Output Control Enable 0 The channel output is not affected by software output control. 1 The channel output is affected by software output control.
0 CH0OC	Channel 0 Software Output Control Enable 0 The channel output is not affected by software output control. 1 The channel output is affected by software output control.

36.3.27 FTM PWM Load (FTMx_PWMLOAD)

Enables the loading of the MOD, CNTIN, C(n)V, and C(n+1)V registers with the values of their write buffers when the FTM counter changes from the MOD register value to its next value or when a channel (j) match occurs. A match occurs for the channel (j) when $FTM\ counter = C(j)V$.

Addresses: FTM0_PWMLOAD is 4003_8000h base + 98h offset = 4003_8098h

FTM1_PWMLOAD is 4003_9000h base + 98h offset = 4003_9098h

FTM2_PWMLOAD is 400B_8000h base + 98h offset = 400B_8098h

Bit	31	30	29	28	27	26	25	24	23	22	21	20	19	18	17	16	
R	0																
W	[Greyed out]																
Reset	0	0	0	0	0	0	0	0	0	0	0	0	0	0	0	0	
Bit	15	14	13	12	11	10	9	8	7	6	5	4	3	2	1	0	
R	0							LDOK	0	CH7SEL	CH6SEL	CH5SEL	CH4SEL	CH3SEL	CH2SEL	CH1SEL	CH0SEL
W	[Greyed out]							[Greyed out]	[Greyed out]	[Greyed out]	[Greyed out]	[Greyed out]	[Greyed out]	[Greyed out]	[Greyed out]	[Greyed out]	[Greyed out]
Reset	0	0	0	0	0	0	0	0	0	0	0	0	0	0	0	0	

FTMx_PWMLOAD field descriptions

Field	Description
31–10 Reserved	This read-only field is reserved and always has the value zero.
9 LDOK	Load Enable Enables the loading of the MOD, CNTIN, and CV registers with the values of their write buffers. 0 Loading updated values is disabled. 1 Loading updated values is enabled.
8 Reserved	This read-only field is reserved and always has the value zero.
7 CH7SEL	Channel 7 Select 0 Do not include the channel in the matching process. 1 Include the channel in the matching process.
6 CH6SEL	Channel 6 Select 0 Do not include the channel in the matching process. 1 Include the channel in the matching process.
5 CH5SEL	Channel 5 Select 0 Do not include the channel in the matching process. 1 Include the channel in the matching process.
4 CH4SEL	Channel 4 Select 0 Do not include the channel in the matching process. 1 Include the channel in the matching process.
3 CH3SEL	Channel 3 Select 0 Do not include the channel in the matching process. 1 Include the channel in the matching process.
2 CH2SEL	Channel 2 Select 0 Do not include the channel in the matching process. 1 Include the channel in the matching process.
1 CH1SEL	Channel 1 Select 0 Do not include the channel in the matching process. 1 Include the channel in the matching process.
0 CH0SEL	Channel 0 Select 0 Do not include the channel in the matching process. 1 Include the channel in the matching process.

36.4 Functional Description

The following sections describe the FTM features.

The notation used in this document to represent the counters and the generation of the signals is shown in the following figure.

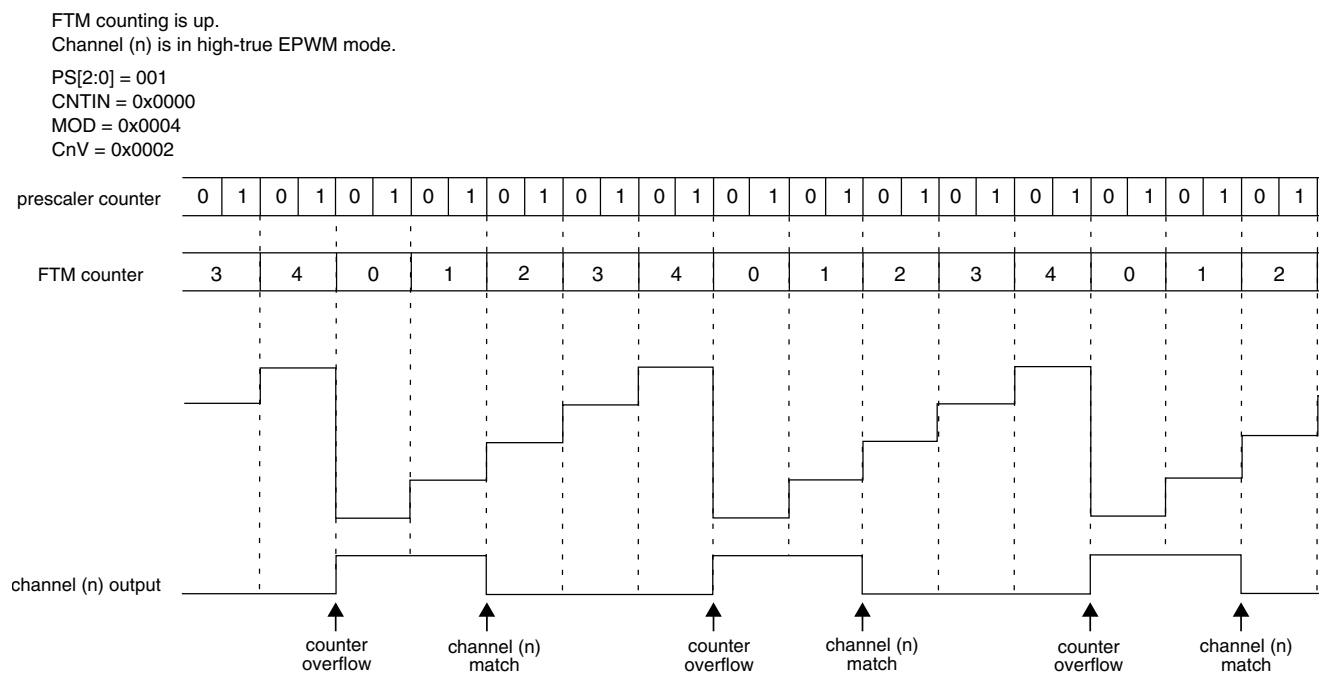

Figure 36-166. Notation Used

36.4.1 Clock Source

FTM module has only one clock domain that is the system clock.

36.4.1.1 Counter Clock Source

The CLKS[1:0] bits in the SC register select one of three possible clock sources for the FTM counter or disable the FTM counter. After any MCU reset, CLKS[1:0] = 0:0 so no clock source is selected.

The CLKS[1:0] bits may be read or written at any time. Disabling the FTM counter by writing 0:0 to the CLKS[1:0] bits does not affect the FTM counter value or other registers.

The fixed frequency clock is an alternative clock source for the FTM counter that allows the selection of a clock other than the system clock or an external clock. This clock input is defined by chip integration. Refer the chip specific documentation for further information. Due to FTM hardware implementation limitations, the frequency of the fixed frequency clock must not exceed 1/2 of the system clock frequency.

The external clock passes through a synchronizer clocked by the system clock to assure that counter transitions are properly aligned to system clock transitions. Therefore, to meet Nyquist criteria considering also jitter, the frequency of the external clock source must not exceed 1/4 of the system clock frequency.

36.4.2 Prescaler

The selected counter clock source passes through a prescaler that is a 7-bit counter. The value of the prescaler is selected by the PS[2:0] bits. The following figure shows an example of the prescaler counter and FTM counter.

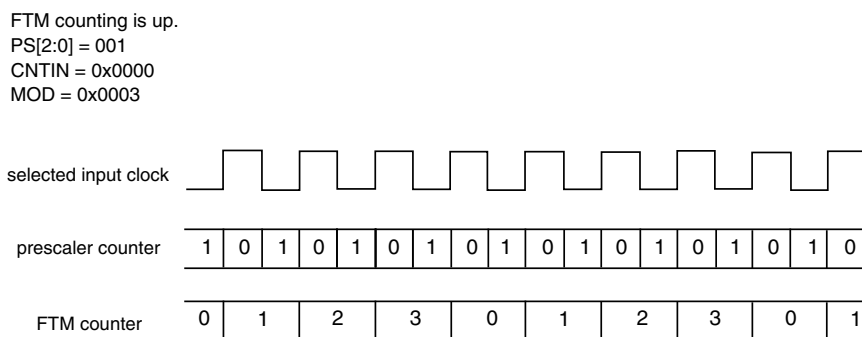

Figure 36-167. Example of the Prescaler Counter

36.4.3 Counter

The FTM has a 16-bit counter that is used by the channels either for input or output modes. The FTM counter clock is the selected clock divided by the prescaler.

The FTM counter has these modes of operation:

- up counting (see [Up Counting](#))
- up-down counting (see [Up-Down Counting](#))
- quadrature mode (see [Quadrature Decoder Mode](#))

36.4.3.1 Up Counting

Up counting is selected when (QUADEN = 0) and (CPWMS = 0).

CNTIN defines the starting value of the count and MOD defines the final value of the count (see the following figure). The value of CNTIN is loaded into the FTM counter, and the counter increments until the value of MOD is reached, at which point the counter is reloaded with the value of CNTIN.

The FTM period when using up counting is $(MOD - CNTIN + 0x0001) \times$ period of the FTM counter clock.

The TOF bit is set when the FTM counter changes from MOD to CNTIN.

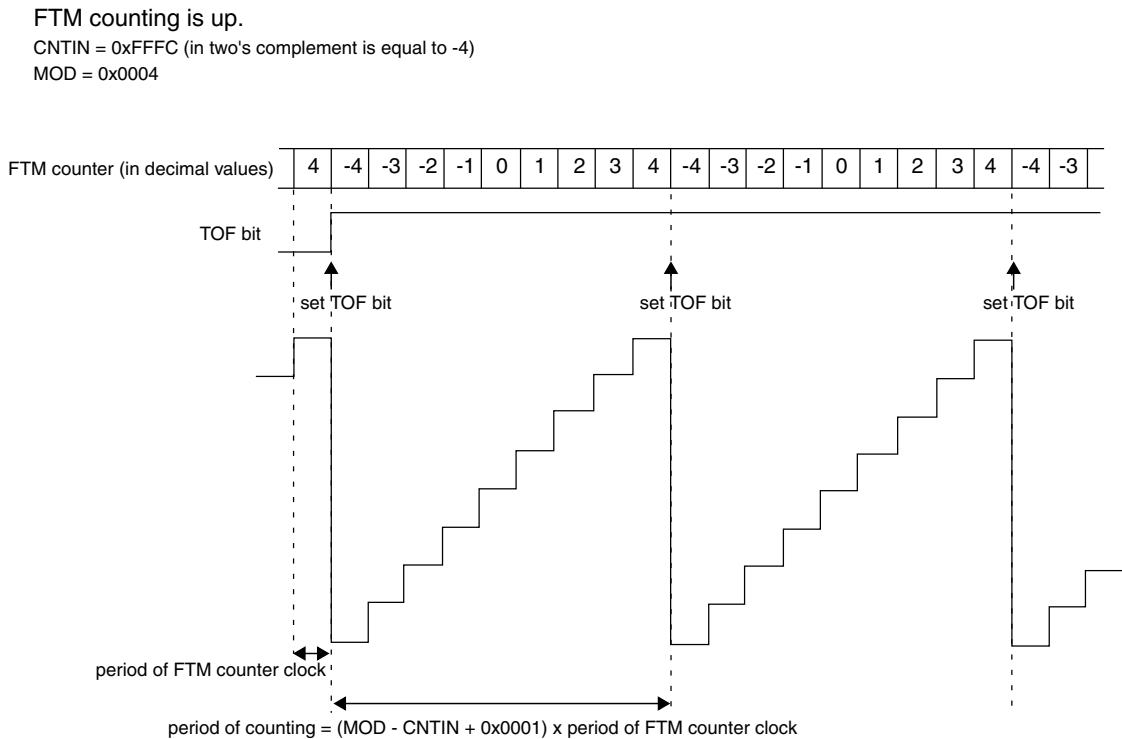

Figure 36-168. Example of FTM Up and Signed Counting

If (CNTIN = 0x0000), the FTM counting is equivalent to TPM up counting (that is, up and unsigned counting) (see the following figure). If (CNTIN[15] = 1), then the initial value of the FTM counter is a negative number in two's complement, so the FTM counting is up and signed. Conversely if (CNTIN[15] = 0 and CNTIN \neq 0x0000), then the initial value of the FTM counter is a positive number, so the FTM counting is up and unsigned.

Functional Description

FTM counting is up
 CNTIN = 0x0000
 MOD = 0x0004

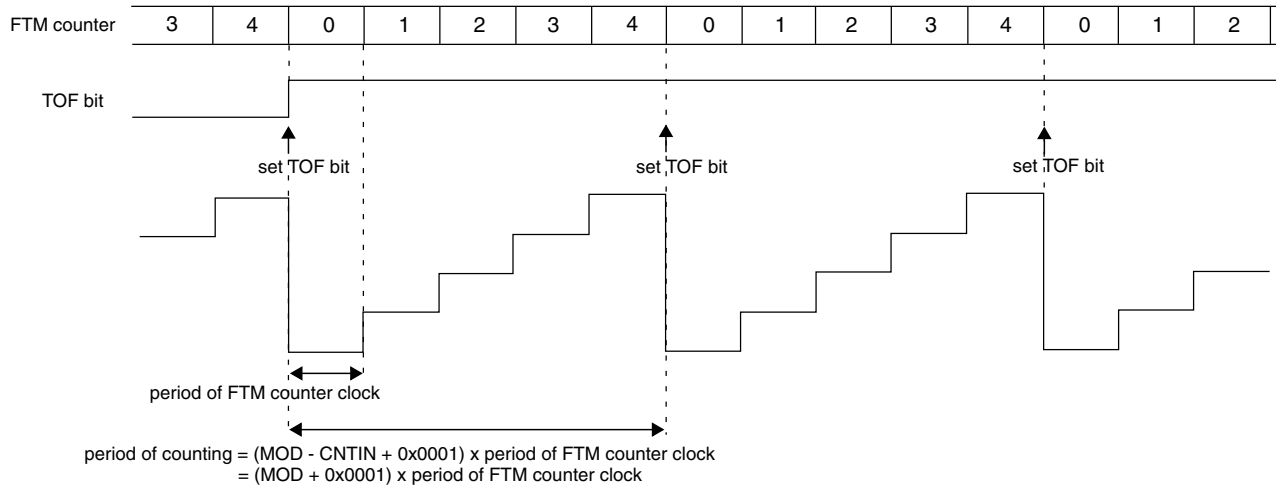

Figure 36-169. Example of FTM Up Counting with CNTIN = 0x0000

Note

- FTM operation is only valid when the value of the CNTIN register is less than the value of the MOD register (either in the unsigned counting or signed counting). It is the responsibility of the software to ensure that the values in the CNTIN and MOD registers meet this requirement. Any values of CNTIN and MOD that do not satisfy this criteria can result in unpredictable behavior.
- MOD = CNTIN is a redundant condition. In this case, the FTM counter is always equal to MOD and the TOF bit is set in each rising edge of the FTM counter clock.
- When MOD = 0x0000, CNTIN = 0x0000 (for example after reset), and FTMEN = 1, the FTM counter remains stopped at 0x0000 until a non-zero value is written into the MOD or CNTIN registers.
- Setting CNTIN to be greater than the value of MOD is not recommended as this unusual setting may make the FTM operation difficult to comprehend. However, there is no restriction on this configuration, and an example is shown in the following figure.

FTM counting is up
 MOD = 0x0005
 CNTIN = 0x0015

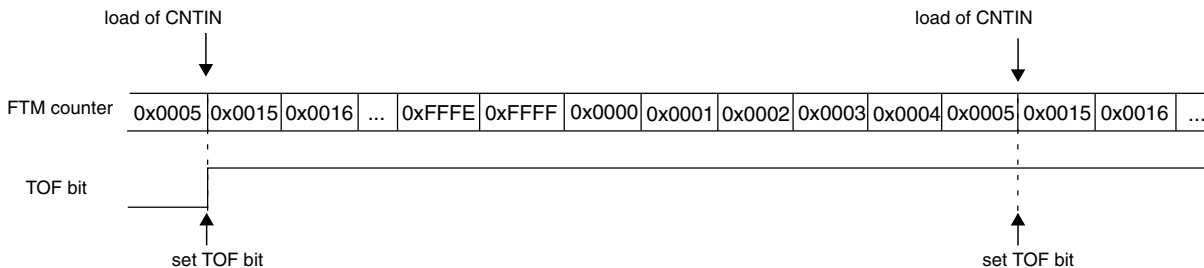

Figure 36-170. Example of Up Counting When the Value of CNTIN Is Greater Than the Value of MOD

36.4.3.2 Up-Down Counting

Up-down counting is selected when (QUADEN= 0) and (CPWMS = 1).

CNTIN defines the starting value of the count and MOD defines the final value of the count. The value of CNTIN is loaded into the FTM counter, and the counter increments until the value of MOD is reached, at which point the counter is decremented until it returns to the value of CNTIN and the up-down counting restarts.

The FTM period when using up-down counting is $2 \times (MOD - CNTIN) \times$ period of the FTM counter clock.

The TOF bit is set when the FTM counter changes from MOD to (MOD – 1).

If (CNTIN = 0x0000), the FTM counting is equivalent to TPM up-down counting (that is, up-down and unsigned counting) (see the following figure).

Functional Description

FTM counting is up-down
 CNTIN = 0x0000
 MOD = 0x0004

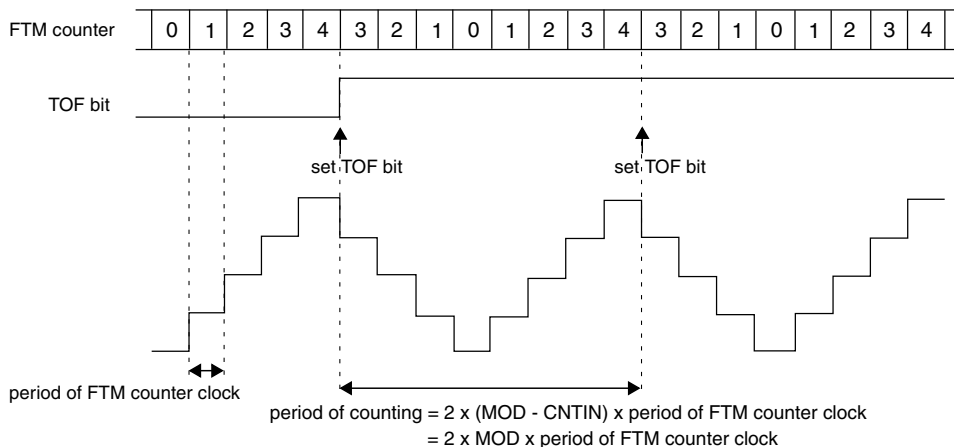

Figure 36-171. Example of Up-Down Counting When CNTIN = 0x0000

Note

It is expected that the up-down counting be used only with CNTIN = 0x0000.

36.4.3.3 Free Running Counter

If (FTMEN = 0) and (MOD = 0x0000 or MOD = 0xFFFF), the FTM counter is a free running counter. In this case, the FTM counter runs free from 0x0000 through 0xFFFF and the TOF bit is set when the FTM counter changes from 0xFFFF to 0x0000 (see the following figure).

FTMEN = 0
 MOD = 0x0000

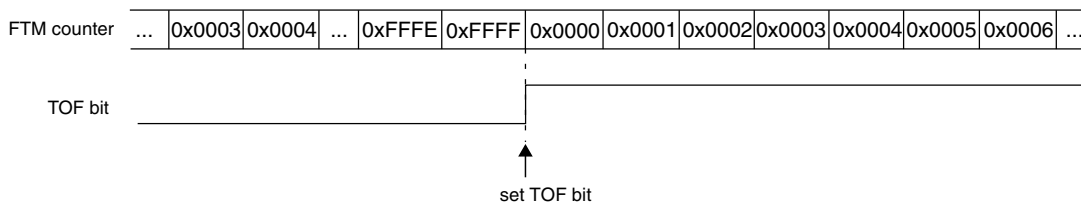

Figure 36-172. Example When the FTM Counter Is a Free Running

If (FTMEN = 1), (QUADEN = 0), (CPWMS = 0), (CNTIN = 0x0000), and (MOD = 0xFFFF), the FTM counter is a free running counter. In this case, the FTM counter runs free from 0x0000 through 0xFFFF and the TOF bit is set when the FTM counter changes from 0xFFFF to 0x0000.

36.4.3.4 Counter Reset

Any write to CNT resets the FTM counter to the value in the CNTIN register and the channels output to its initial value (except for channels in output compare mode).

The FTM counter synchronization (see [FTM Counter Synchronization](#)) can also be used to force the value of CNTIN into the FTM counter and the channels output to its initial value (except for channels in output compare mode).

36.4.3.5 When the TOF Bit is Set

The NUMTOF[4:0] bits define the number of times that the FTM counter overflow should occur before the TOF bit to be set. If NUMTOF[4:0] = 0x00, then the TOF bit is set at each FTM counter overflow.

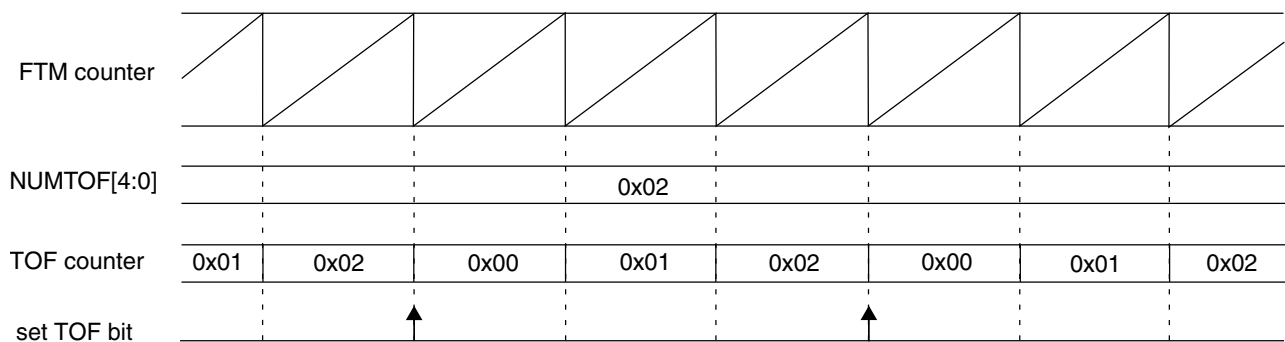

Figure 36-173. Periodic TOF When NUMTOF = 0x02

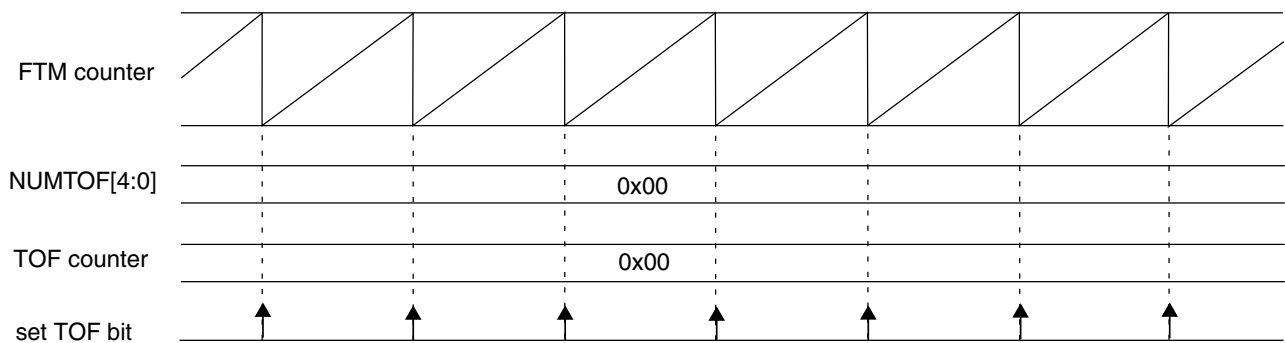

Figure 36-174. Periodic TOF When NUMTOF = 0x00

36.4.4 Input Capture Mode

The input capture mode is selected when (DECAPEN = 0), (COMBINE = 0), (CPWMS = 0), (MSnB:MSnA = 0:0), and (ELSnB:ELSnA ≠ 0:0).

Functional Description

When a selected edge occurs on the channel input, the current value of the FTM counter is captured into the CnV register, at the same time the CHnF bit is set and the channel interrupt is generated if enabled by CHnIE = 1 (see the following figure).

When a channel is configured for input capture, the FTMxCHn pin is an edge-sensitive input. ELSnB:ELSnA control bits determine which edge, falling or rising, triggers input-capture event. Note that the maximum frequency for the channel input signal to be detected correctly is system clock divided by 4, which is required to meet Nyquist criteria for signal sampling.

Writes to the CnV register is ignored in input capture mode.

While in BDM, the input capture function works as configured. When a selected edge event occurs, the FTM counter value (which is frozen because of BDM) is captured into the CnV register and the CHnF bit is set.

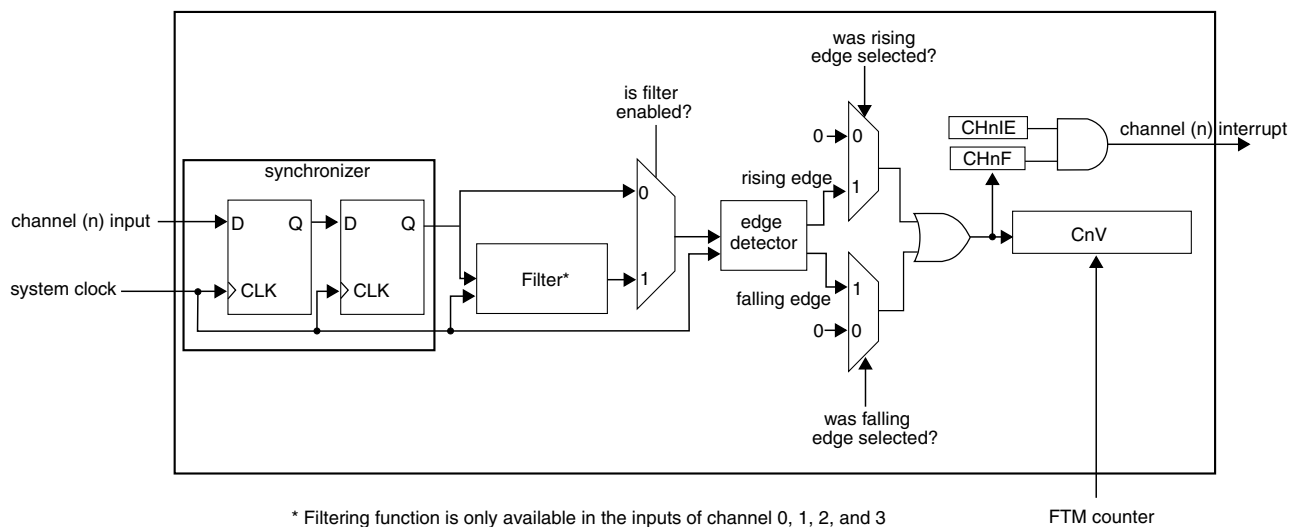

Figure 36-175. Input Capture Mode

If the channel input does not have a filter enabled, then the input signal is always delayed 3 rising edges of the system clock (two rising edges to the synchronizer plus one more rising edge to the edge detector). In other words, the CHnF bit is set on the third rising edge of the system clock after a valid edge occurs on the channel input.

Note

It is expected that the input capture mode be used only with CNTIN = 0x0000.

36.4.4.1 Filter for Input Capture Mode

The filter function is only available on channels 0, 1, 2, and 3.

Firstly the input signal is synchronized by the system clock. Following synchronization, the input signal enters the filter block (see the following figure). When there is a state change in the input signal, the 5-bit counter is reset and starts counting up. As long as the new state is stable on the input, the counter continues to increment. If the 5-bit counter overflows (the counter exceeds the value of the CHnFVAL[3:0] bits), the state change of the input signal is validated. It is then transmitted as a pulse edge to the edge detector.

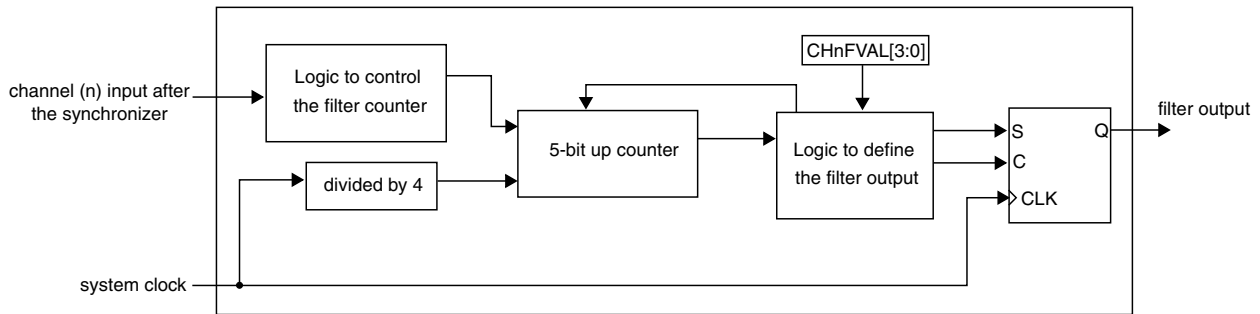

Figure 36-176. Channel Input Filter

If the opposite edge appears on the input signal before validation (counter overflow), the counter is reset. At the next input transition, the counter starts counting again. Any pulse that is shorter than the minimum value selected by CHnFVAL[3:0] bits ($\times 4$ system clocks) is regarded as a glitch and is not passed on to the edge detector. A timing diagram of the input filter is shown in the following figure.

The filter function is disabled when CHnFVAL[3:0] bits are zero. In this case, the input signal is delayed 3 rising edges of the system clock. If $(CHnFVAL[3:0] \neq 0000)$, then the input signal is delayed by the minimum pulse width $(CHnFVAL[3:0] \times 4$ system clocks) plus a further 4 rising edges of the system clock (two rising edges to the synchronizer, one rising edge to the filter output plus one more to the edge detector). In other words, CHnF is set $(4 + 4 \times CHnFVAL[3:0])$ system clock periods after a valid edge occurs on the channel input.

The clock for the 5-bit counter in the channel input filter is the system clock divided by 4.

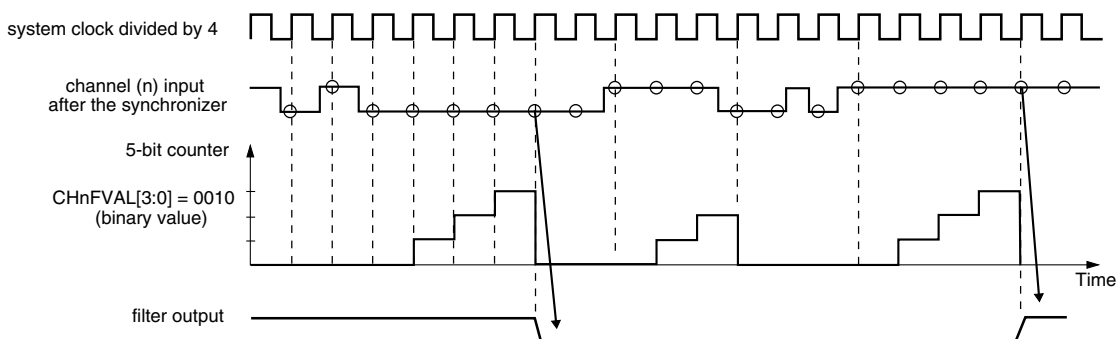

Figure 36-177. Channel Input Filter Example

36.4.5 Output Compare Mode

The output compare mode is selected when (DECAPEN = 0), (COMBINE = 0), (CPWMS = 0), and (MSnB:MSnA = 0:1).

In output compare mode, the FTM can generate timed pulses with programmable position, polarity, duration, and frequency. When the counter matches the value in the CnV register of an output compare channel, the channel (n) output can be set, cleared, or toggled.

When a channel is initially configured to toggle mode, the previous value of the channel output is held until the first output compare event occurs.

The CHnF bit is set and the channel (n) interrupt is generated (if CHnIE = 1) at the channel (n) match (FTM counter = CnV).

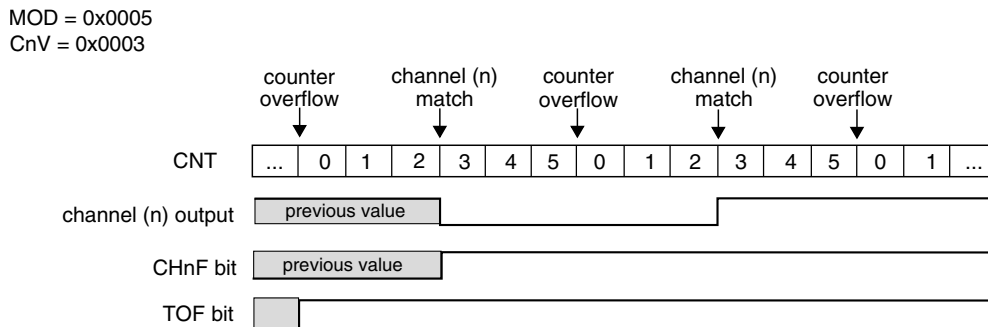

Figure 36-178. Example of the Output Compare Mode when the Match Toggles the Channel Output

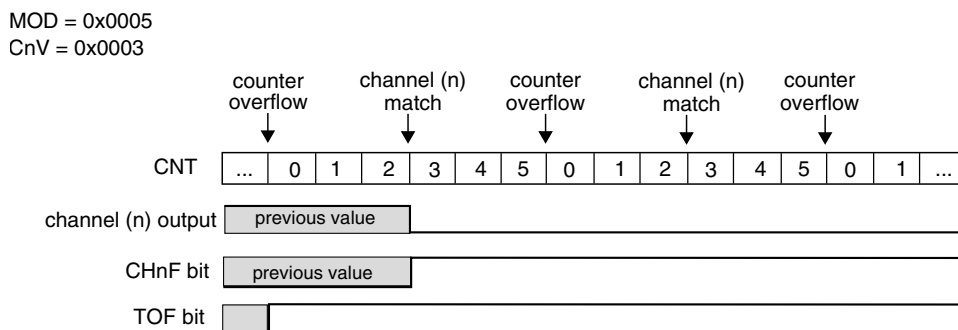

Figure 36-179. Example of the Output Compare Mode when the Match Clears the Channel Output

MOD = 0x0005
CnV = 0x0003

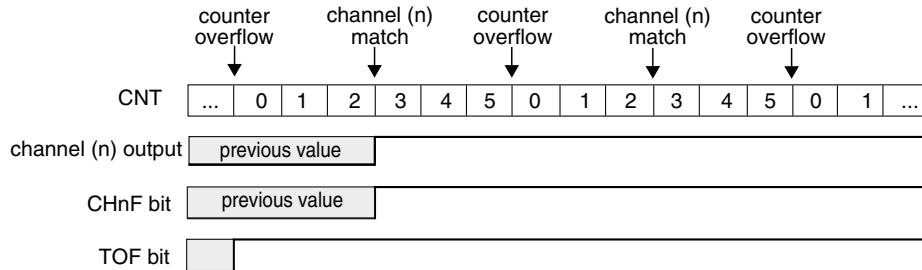

Figure 36-180. Example of the Output Compare Mode when the Match Sets the Channel Output

It is possible to use the output compare mode with (ELSnB:ELSnA = 0:0). In this case, when the counter reaches the value in the CnV register, the CHnF bit is set and the channel (n) interrupt is generated (if CHnIE = 1), however the channel (n) output is not modified and controlled by FTM.

Note

It is expected that the output compare mode be used only with CNTIN = 0x0000.

36.4.6 Edge-Aligned PWM (EPWM) Mode

The edge-aligned mode is selected when (QUADEN = 0), (DECAPEN = 0), (COMBINE = 0), (CPWMS = 0), and (MSnB = 1).

The EPWM period is determined by (MOD – CNTIN + 0x0001) and the pulse width (duty cycle) is determined by (CnV – CNTIN).

The CHnF bit is set and the channel (n) interrupt is generated (if CHnIE = 1) at the channel (n) match (FTM counter = CnV), that is, at the end of the pulse width.

This type of PWM signal is called edge-aligned because the leading edges of all PWM signals are aligned with the beginning of the period, which is the same for all channels within an FTM.

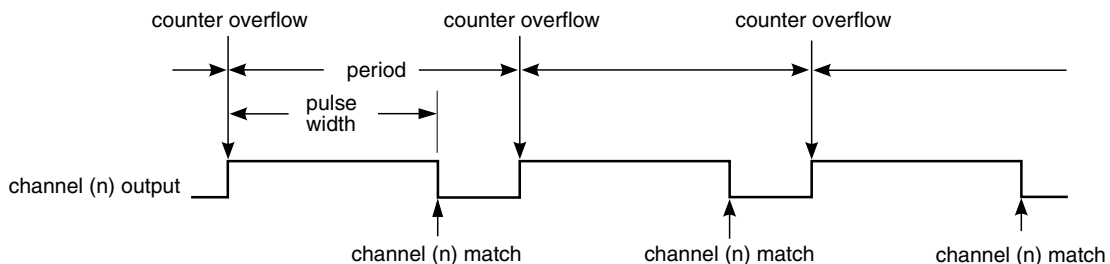

Figure 36-181. EPWM Period and Pulse Width with ELSnB:ELSnA = 1:0

If (ELSnB:ELSnA = 0:0) when the counter reaches the value in the CnV register, the CHnF bit is set and the channel (n) interrupt is generated (if CHnIE = 1), however the channel (n) output is not controlled by FTM.

If (ELSnB:ELSnA = 1:0), then the channel (n) output is forced high at the counter overflow (when the CNTIN register value is loaded into the FTM counter), and it is forced low at the channel (n) match (FTM counter = CnV) (see the following figure).

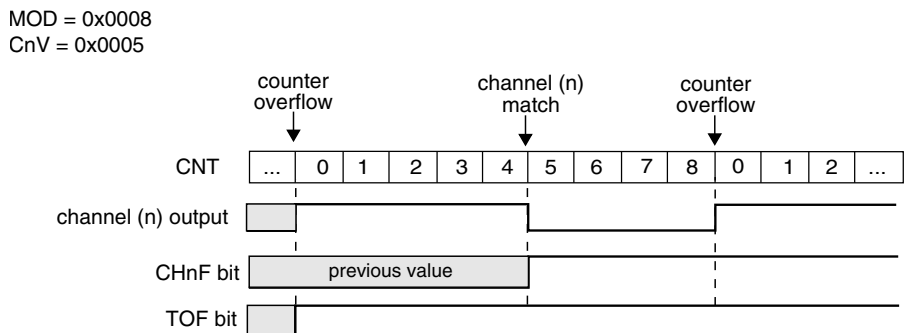

Figure 36-182. EPWM Signal with ELSnB:ELSnA = 1:0

If (ELSnB:ELSnA = X:1), then the channel (n) output is forced low at the counter overflow (when the CNTIN register value is loaded into the FTM counter), and it is forced high at the channel (n) match (FTM counter = CnV) (see the following figure).

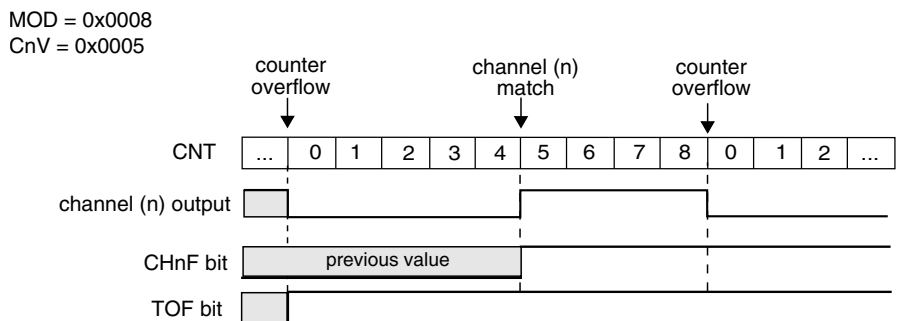

Figure 36-183. EPWM Signal with ELSnB:ELSnA = X:1

If (CnV = 0x0000), then the channel (n) output is a 0% duty cycle EPWM signal and CHnF bit is not set even when there is the channel (n) match. If (CnV > MOD), then the channel (n) output is a 100% duty cycle EPWM signal and CHnF bit is not set even when there is the channel (n) match. Therefore, MOD must be less than 0xFFFF in order to get a 100% duty cycle EPWM signal.

Note

It is expected that the EPWM mode be used only with CNTIN = 0x0000.

36.4.7 Center-Aligned PWM (CPWM) Mode

The center-aligned mode is selected when (QUADEN = 0), (DECAPEN = 0), (COMBINE = 0), and (CPWMS = 1).

The CPWM pulse width (duty cycle) is determined by $2 \times (CnV - CNTIN)$ and the period is determined by $2 \times (MOD - CNTIN)$ (see the following figure). MOD must be kept in the range of 0x0001 to 0x7FFF because values outside this range can produce ambiguous results.

In the CPWM mode, the FTM counter counts up until it reaches MOD and then counts down until it reaches CNTIN.

The CHnF bit is set and channel (n) interrupt is generated (if CHnIE = 1) at the channel (n) match (FTM counter = CnV) when the FTM counting is down (at the begin of the pulse width) and when the FTM counting is up (at the end of the pulse width).

This type of PWM signal is called center-aligned because the pulse width centers for all channels are aligned with the value of CNTIN.

The other channel modes are not compatible with the up-down counter (CPWMS = 1). Therefore, all FTM channels must be used in CPWM mode when (CPWMS = 1).

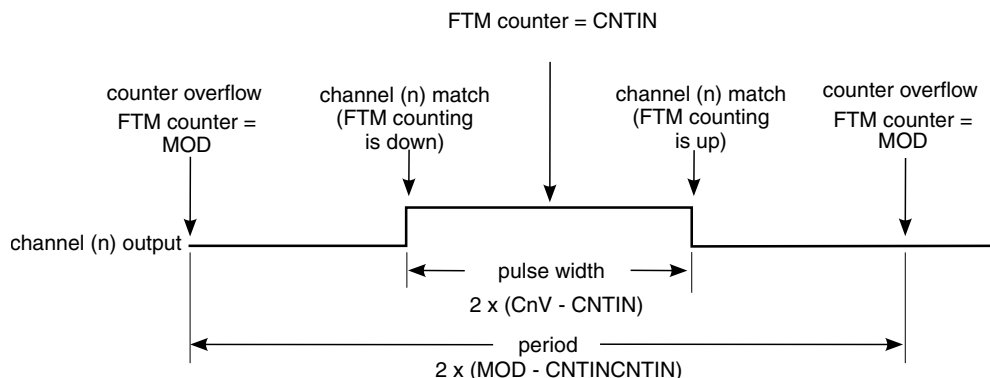

Figure 36-184. CPWM Period and Pulse Width with ELSnB:ELSnA = 1:0

If (ELSnB:ELSnA = 0:0) when the FTM counter reaches the value in the CnV register, the CHnF bit is set and the channel (n) interrupt is generated (if CHnIE = 1), however the channel (n) output is not controlled by FTM.

If (ELSnB:ELSnA = 1:0), then the channel (n) output is forced high at the channel (n) match (FTM counter = CnV) when counting down, and it is forced low at the channel (n) match when counting up (see the following figure).

functional Description

MOD = 0x0008
CnV = 0x0005

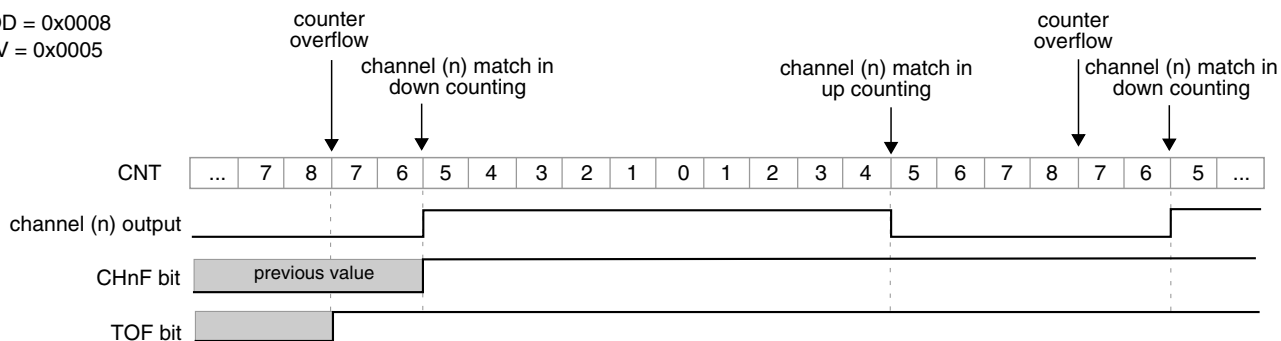

Figure 36-185. CPWM Signal with ELSnB:ELSnA = 1:0

If (ELSnB:ELSnA = X:1), then the channel (n) output is forced low at the channel (n) match (FTM counter = CnV) when counting down, and it is forced high at the channel (n) match when counting up (see the following figure).

MOD = 0x0008
CnV = 0x0005

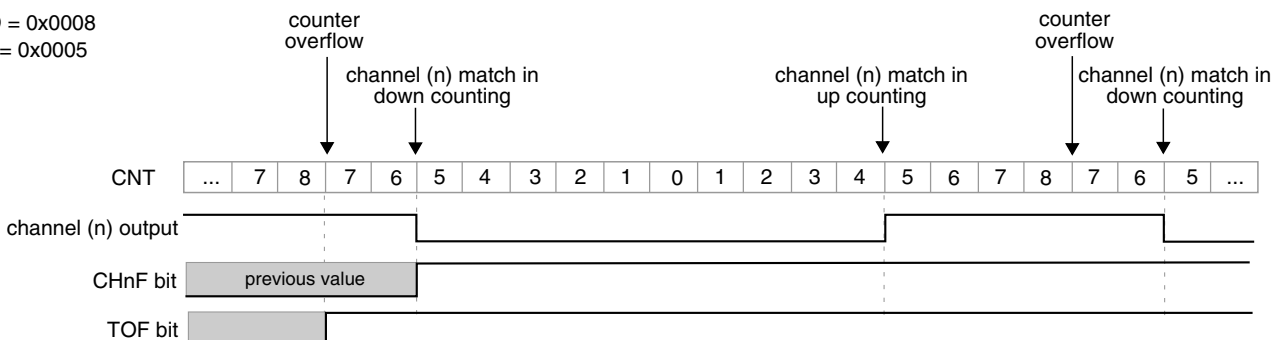

Figure 36-186. CPWM Signal with ELSnB:ELSnA = X:1

If (CnV = 0x0000) or (CnV is a negative value, that is, CnV[15] = 1) then the channel (n) output is a 0% duty cycle CPWM signal and CHnF bit is not set even when there is the channel (n) match.

If (CnV is a positive value, that is, CnV[15] = 0), (CnV ≥ MOD), and (MOD ≠ 0x0000), then the channel (n) output is a 100% duty cycle CPWM signal and CHnF bit is not set even when there is the channel (n) match. This implies that the usable range of periods set by MOD is 0x0001 through 0x7FFE (0x7FFF if you do not need to generate a 100% duty cycle CPWM signal). This is not a significant limitation because the resulting period is much longer than required for normal applications.

The CPWM mode must not be used when the FTM counter is a free running counter.

Note

It is expected that the CPWM mode be used only with CNTIN = 0x0000.

36.4.8 Combine Mode

The combine mode is selected when (FTMEN = 1), (QUADEN = 0), (DECAPEN = 0), (COMBINE = 1), and (CPWMS = 0).

In combine mode, the channel (n) (an even channel) and channel (n+1) (the adjacent odd channel) are combined to generate a PWM signal in the channel (n) output.

In the combine mode, the PWM period is determined by $(MOD - CNTIN + 0x0001)$ and the PWM pulse width (duty cycle) is determined by $(IC(n+1)V - C(n)V)$.

The CHnF bit is set and the channel (n) interrupt is generated (if CHnIE = 1) at the channel (n) match (FTM counter = C(n)V). The CH(n+1)F bit is set and the channel (n+1) interrupt is generated (if CH(n+1)IE = 1) at the channel (n+1) match (FTM counter = C(n+1)V).

If (ELSnB:ELSnA = 1:0), then the channel (n) output is forced low at the beginning of the period (FTM counter = CNTIN) and at the channel (n+1) match (FTM counter = C(n+1)V). It is forced high at the channel (n) match (FTM counter = C(n)V) (see the following figure).

If (ELSnB:ELSnA = X:1), then the channel (n) output is forced high at the beginning of the period (FTM counter = CNTIN) and at the channel (n+1) match (FTM counter = C(n+1)V). It is forced low at the channel (n) match (FTM counter = C(n)V) (see the following figure).

In combine mode, the ELS(n+1)B and ELS(n+1)A bits are not used in the generation of the channels (n) and (n+1) output. However, if (ELSnB:ELSnA = 0:0) then the channel (n) output is not controlled by FTM, and if (ELSnB:ELSnA = 0:0) then the channel (n+1) output is not controlled by FTM.

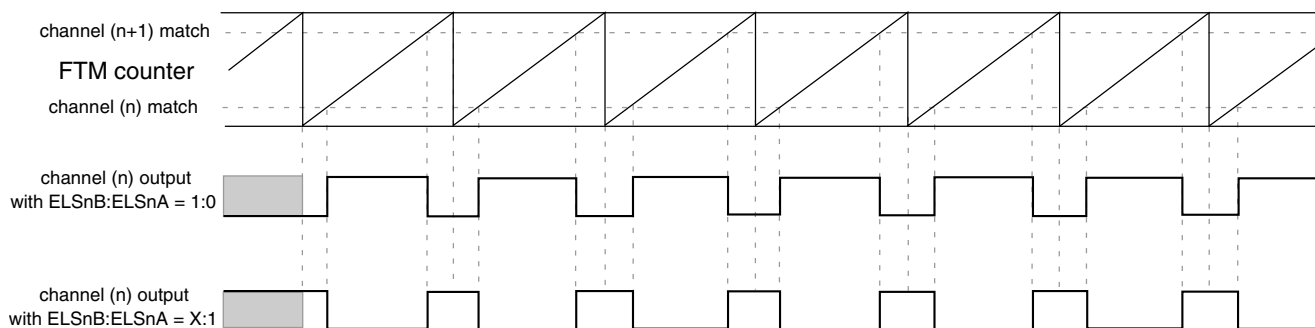

Figure 36-187. Combine Mode

The following figures illustrate the PWM signals generation using combine mode.

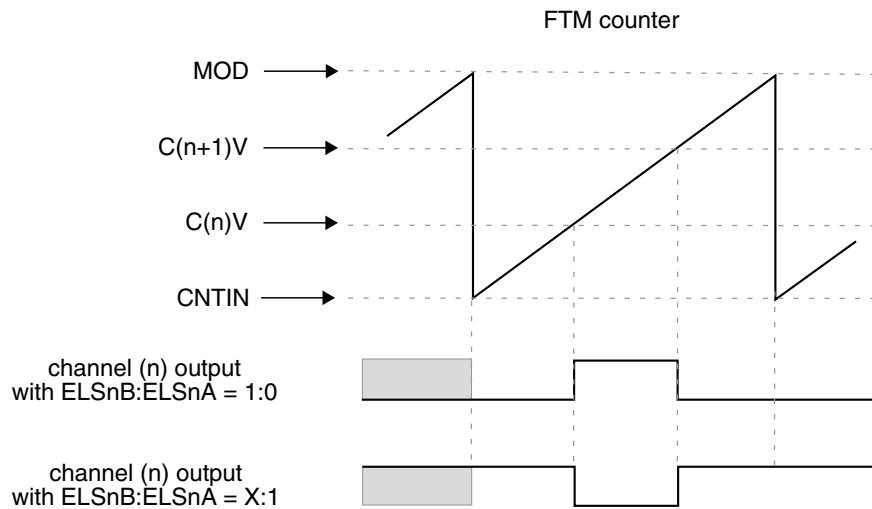

Figure 36-188. Channel (n) Output If $(CNTIN < C(n)V < MOD)$ and $(CNTIN < C(n+1)V < MOD)$ and $(C(n)V < C(n+1)V)$

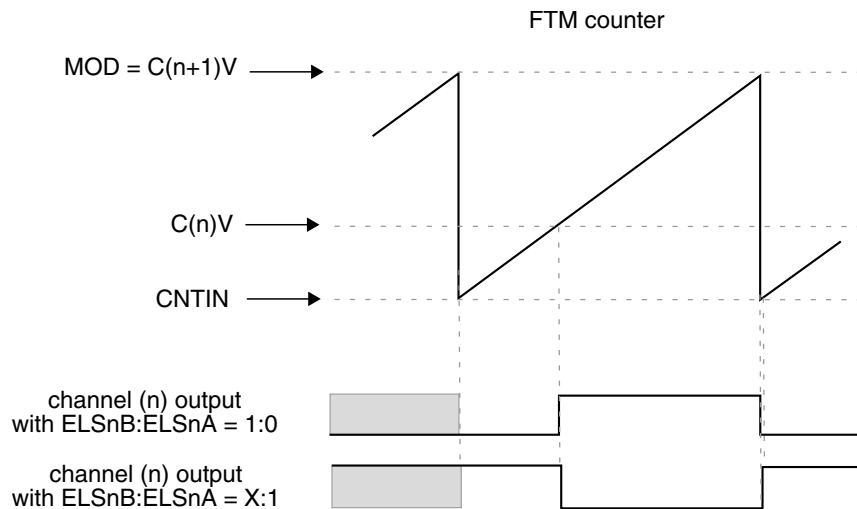

Figure 36-189. Channel (n) Output If $(CNTIN < C(n)V < MOD)$ and $(C(n+1)V = MOD)$

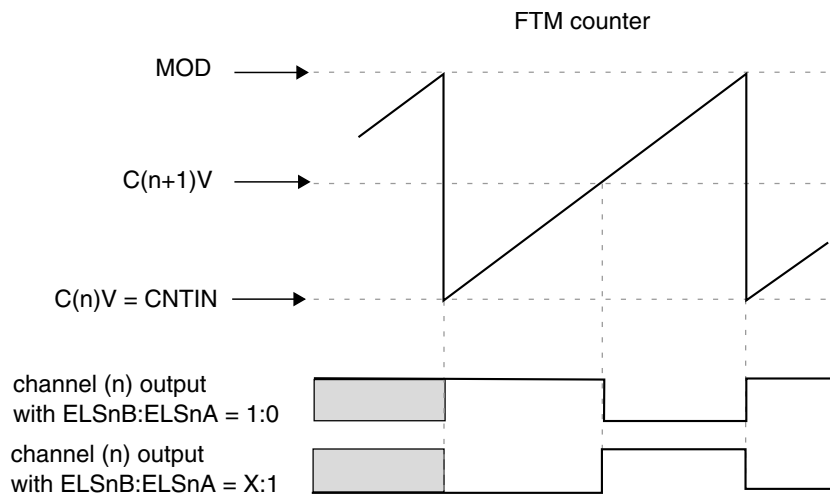

Figure 36-190. Channel (n) Output If $(C(n)V = CNTIN)$ and $(CNTIN < C(n+1)V < MOD)$

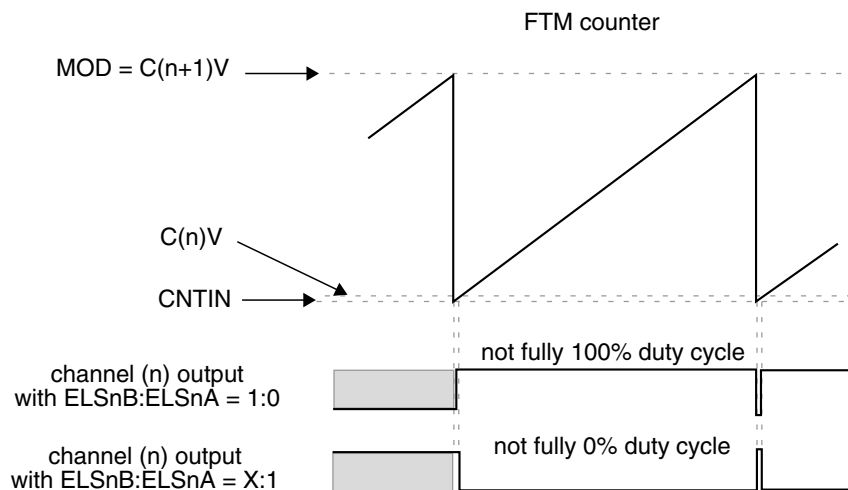

Figure 36-191. Channel (n) Output If ($CNTIN < C(n)V < MOD$) and ($C(n)V$ is Almost Equal to $CNTIN$) and ($C(n+1)V = MOD$)

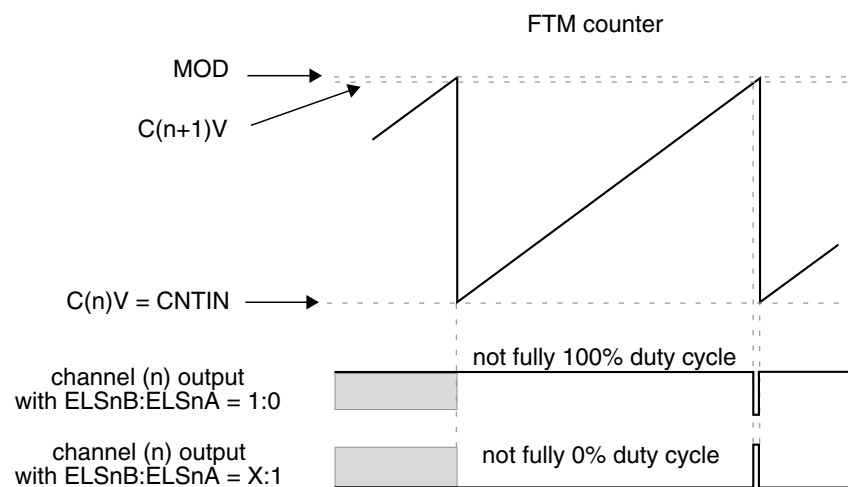

Figure 36-192. Channel (n) Output If ($C(n)V = CNTIN$) and ($CNTIN < C(n+1)V < MOD$) and ($C(n+1)V$ is Almost Equal to MOD)

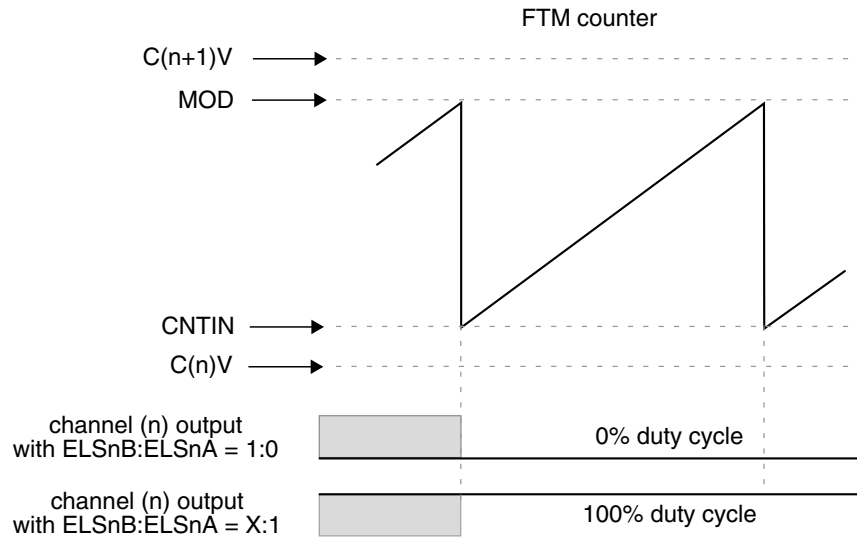

Figure 36-193. Channel (n) Output If C(n)V and C(n+1)V Are Not Between CNTIN and MOD

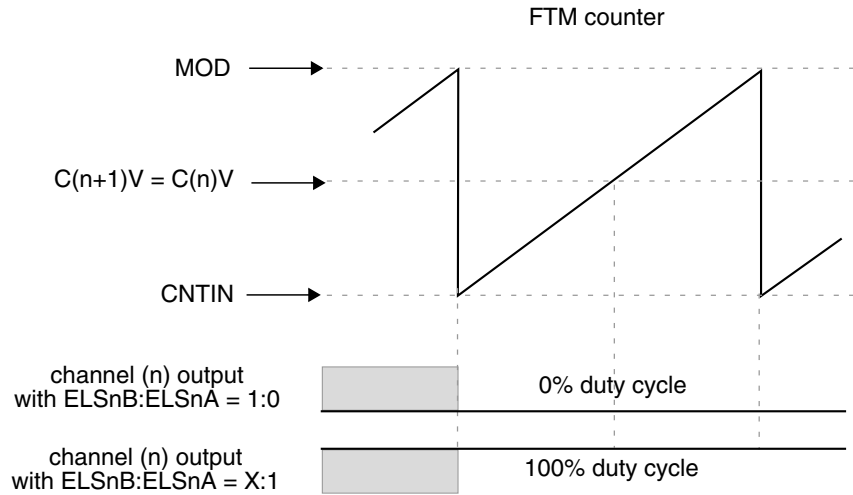

Figure 36-194. Channel (n) Output If (CNTIN < C(n)V < MOD) and (CNTIN < C(n+1)V < MOD) and (C(n)V = C(n+1)V)

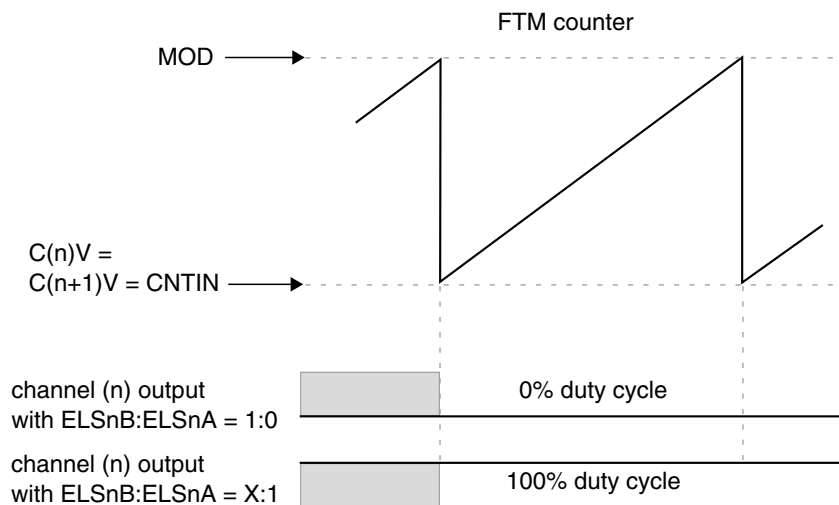

Figure 36-195. Channel (n) Output If $(C(n)V = C(n+1)V = CNTIN)$

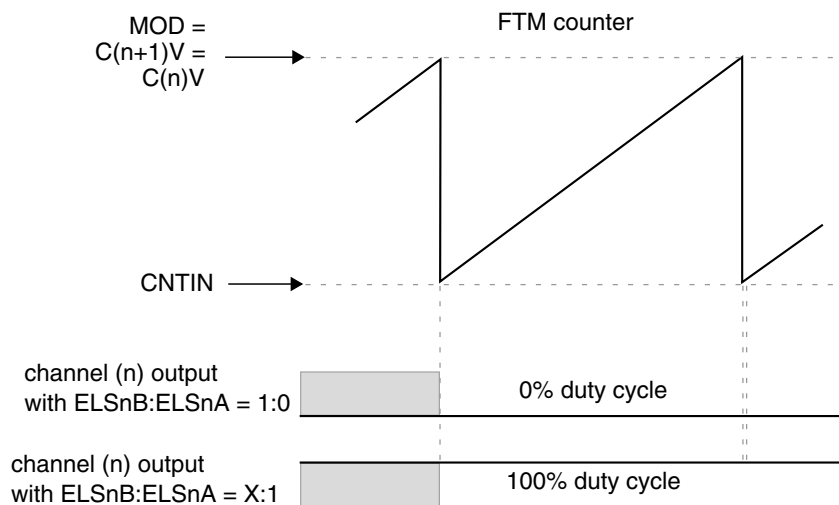

Figure 36-196. Channel (n) Output If $(C(n)V = C(n+1)V = MOD)$

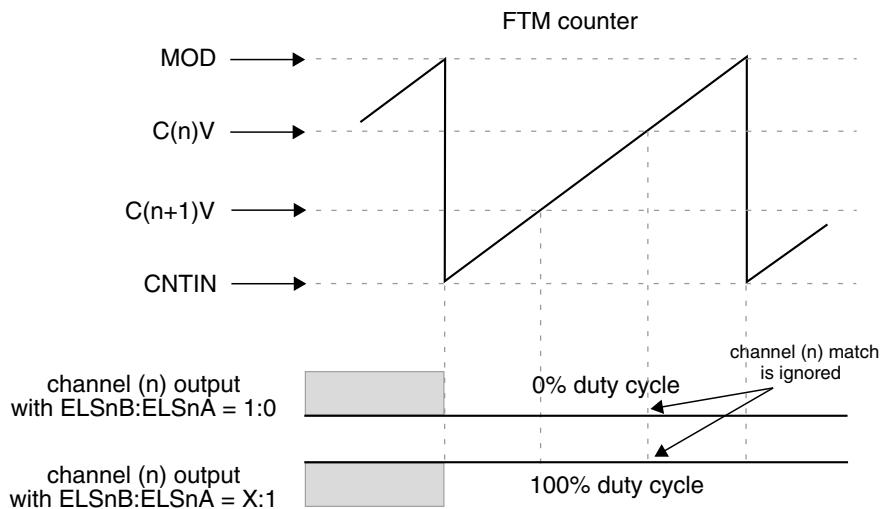

Figure 36-197. Channel (n) Output If $(CNTIN < C(n)V < MOD)$ and $(CNTIN < C(n+1)V < MOD)$ and $(C(n)V > C(n+1)V)$

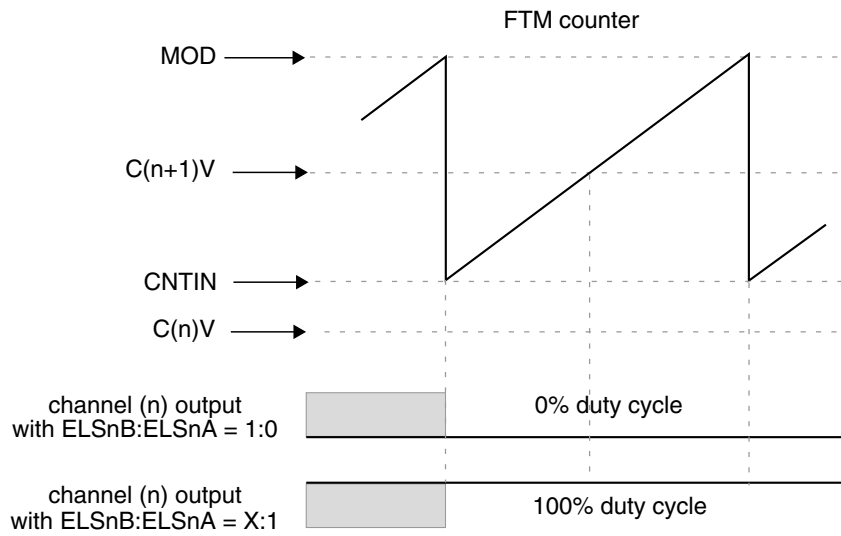

Figure 36-198. Channel (n) Output If $(C(n)V < CNTIN)$ and $(CNTIN < C(n+1)V < MOD)$

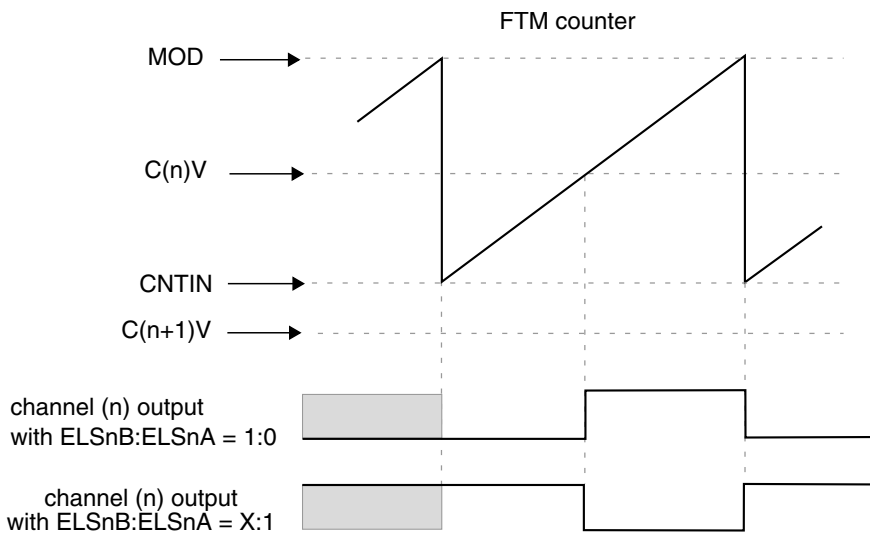

Figure 36-199. Channel (n) Output If $(C(n+1)V < CNTIN)$ and $(CNTIN < C(n)V < MOD)$

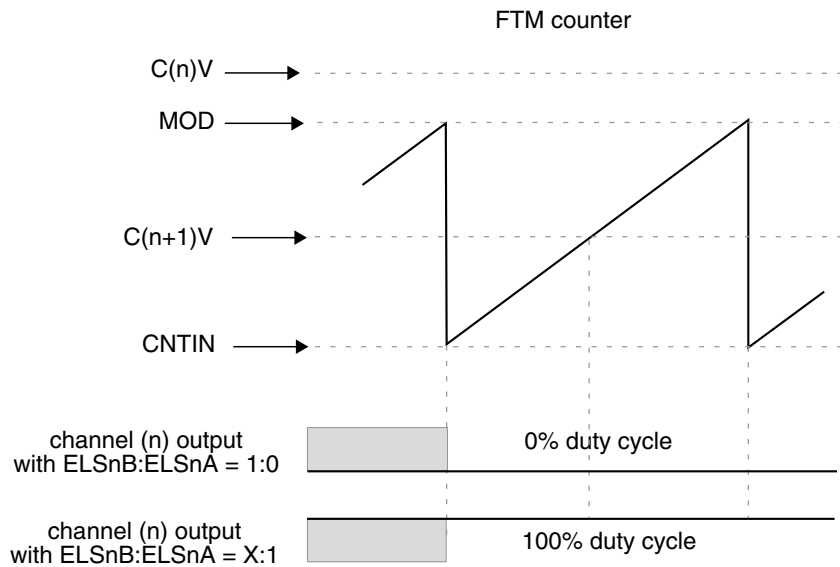

Figure 36-200. Channel (n) Output If $(C(n)V > MOD)$ and $(CNTIN < C(n+1)V < MOD)$

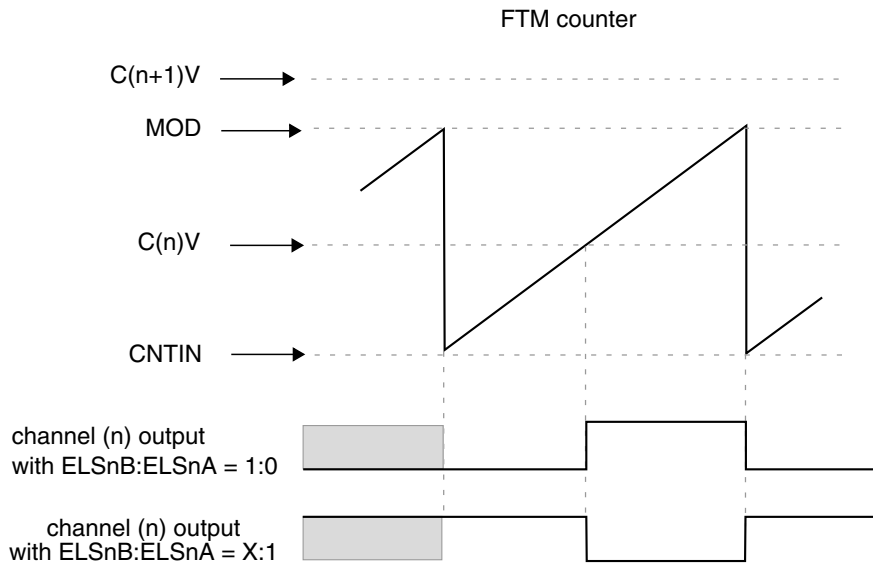

Figure 36-201. Channel (n) Output If $(C(n+1)V > MOD)$ and $(CNTIN < C(n)V < MOD)$

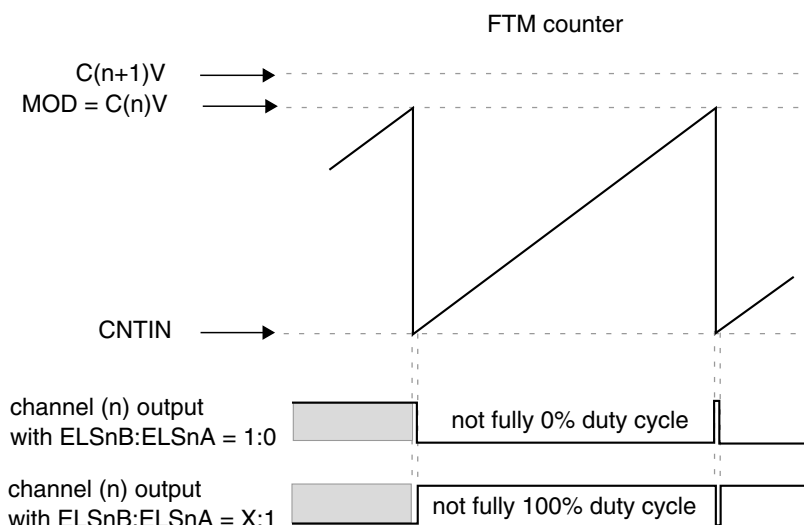

Figure 36-202. Channel (n) Output If $C(n+1)V > MOD$ and $CNTIN < C(n)V = MOD$

36.4.8.1 Asymmetrical PWM

In combine mode, the control of the PWM signal first edge (when the channel (n) match occurs, that is, FTM counter = $C(n)V$) is independent of the control of the PWM signal second edge (when the channel (n+1) match occurs, that is, FTM counter = $C(n+1)V$). So, combine mode allows the generation of asymmetrical PWM signals.

36.4.9 Complementary Mode

The complementary mode is selected when $(FTMEN = 1)$, $(QUADEN = 0)$, $(DECAPEN = 0)$, $(COMBINE = 1)$, $(CPWMS = 0)$, and $(COMP = 1)$.

In complementary mode the channel (n+1) output is the inverse of the channel (n) output.

If $(FTMEN = 1)$, $(QUADEN = 0)$, $(DECAPEN = 0)$, $(COMBINE = 1)$, $(CPWMS = 0)$, and $(COMP = 0)$, then the channel (n+1) output is the same as the channel (n) output.

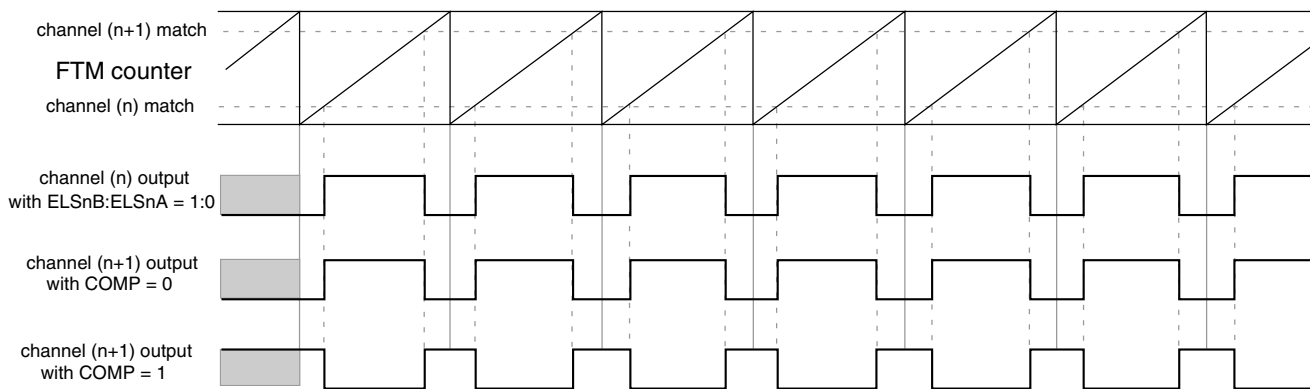

Figure 36-203. Channel (n+1) Output in Complementary Mode with $(ELSnB:ELSnA = 1:0)$

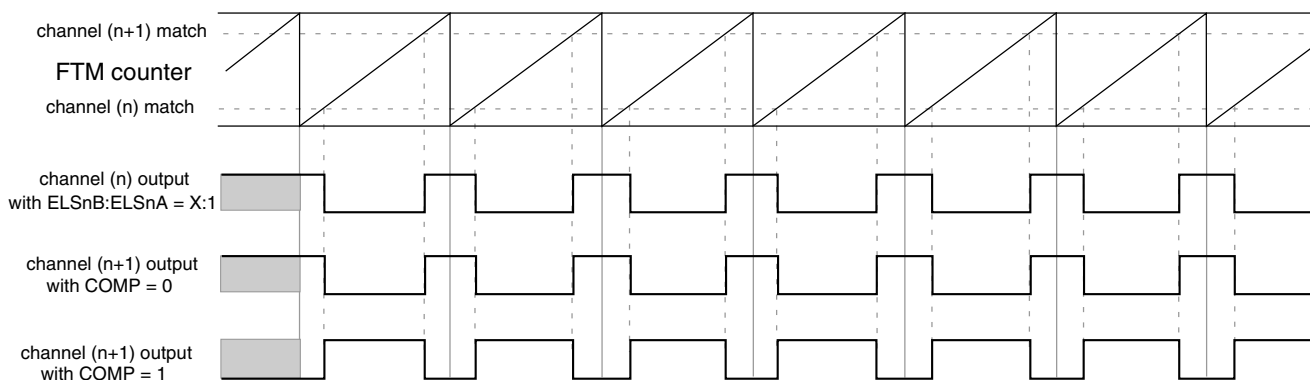

Figure 36-204. Channel (n+1) Output in Complementary Mode with $(ELSnB:ELSnA = X:1)$

36.4.10 Registers Updated from Write Buffers

36.4.10.1 CNTIN Register Update

If $(CLKS[1:0] = 0:0)$ then CNTIN register is updated when CNTIN register is written (independent of FTMEN bit).

If $(FTMEN = 0)$ or $(CNTINC = 0)$ then CNTIN register is updated at the next system clock after CNTIN was written.

If $(FTMEN = 1)$, $(SYNCCMODE = 1)$ and $(CNTINC = 1)$ then CNTIN register is updated by the CNTIN register synchronization ([CNTIN Register Synchronization](#)).

36.4.10.2 MOD Register Update

If $(CLKS[1:0] = 0:0)$ then MOD register is updated when MOD register is written (independent of FTMEN bit).

If ($CLKS[1:0] \neq 0:0$ and $FTMEN = 0$), then MOD register is updated according to the CPWMS bit, that is:

- If the selected mode is not CPWM then MOD register is updated after MOD register was written and the FTM counter changes from MOD to CNTIN. If the FTM counter is at free-running counter mode then this update occurs when the FTM counter changes from 0xFFFF to 0x0000.
- If the selected mode is CPWM then MOD register is updated after MOD register was written and the FTM counter changes from MOD to $(MOD - 0x0001)$.

If ($CLKS[1:0] \neq 0:0$ and $FTMEN = 1$) then MOD register is updated by the MOD register synchronization ([MOD Register Synchronization](#)).

36.4.10.3 CnV Register Update

If ($CLKS[1:0] = 0:0$) then CnV register is updated when CnV register is written (independent of FTMEN bit).

If ($CLKS[1:0] \neq 0:0$ and $FTMEN = 0$), then CnV register is updated according to the selected mode, that is:

- If the selected mode is output compare then CnV register is updated on the next FTM counter change (end of the prescaler counting) after CnV register was written.
- If the selected mode is EPWM then CnV register is updated after CnV register was written and the FTM counter changes from MOD to CNTIN. If the FTM counter is at free-running counter mode then this update occurs when the FTM counter changes from 0xFFFF to 0x0000.
- If the selected mode is CPWM then CnV register is updated after CnV register was written and the FTM counter changes from MOD to $(MOD - 0x0001)$.

If ($CLKS[1:0] \neq 0:0$ and $FTMEN = 1$) then CnV register is updated according to the selected mode, that is:

- If the selected mode is output compare then CnV register is updated according to the SYNCEN bit. If (SYNCEN = 0) then CnV register is updated after CnV register was written at the next change of the FTM counter (end of the prescaler counting). If (SYNCEN = 1) then CnV register is updated by the CnV register synchronization (C(n)V and C(n+1)V Register Synchronization).
- If the selected mode is not output compare and (SYNCEN = 1) then CnV register is updated by the CnV register synchronization (C(n)V and C(n+1)V Register Synchronization).

36.4.11 PWM Synchronization

The PWM synchronization provides an opportunity to update the MOD, CNTIN, CnV, OUTMASK, INVCTRL and SWOCTRL registers with their buffered value and force the FTM counter to the CNTIN register value.

Note

- It is expected that the PWM synchronization be used only in combine mode.
- The legacy PWM synchronization (SYNCMODE = 0) is a subset of the enhanced PWM synchronization (SYNCMODE = 1). Thus, it is expected that only the enhanced PWM synchronization be used.

36.4.11.1 Hardware Trigger

Three hardware trigger signal inputs of the FTM module are enabled when TRIGN = 1 (where n = 0, 1 or 2 corresponding to each one of the input signals, respectively). The hardware trigger input n is synchronized by the system clock. The PWM synchronization with hardware trigger is initiated when a rising edge is detected at the enabled hardware trigger inputs.

If (HWTRIGMODE = 0) then the TRIGN bit is cleared when 0 is written to it or when the trigger n event is detected.

In this case if two or more hardware triggers are enabled (for example, TRIG0 and TRIG1 = 1) and only trigger 1 event occurs then only TRIG1 bit is cleared. If a trigger n event occurs together with a write setting TRIGN bit then the synchronization is initiated, but TRIGN bit remains set due to the write operation.

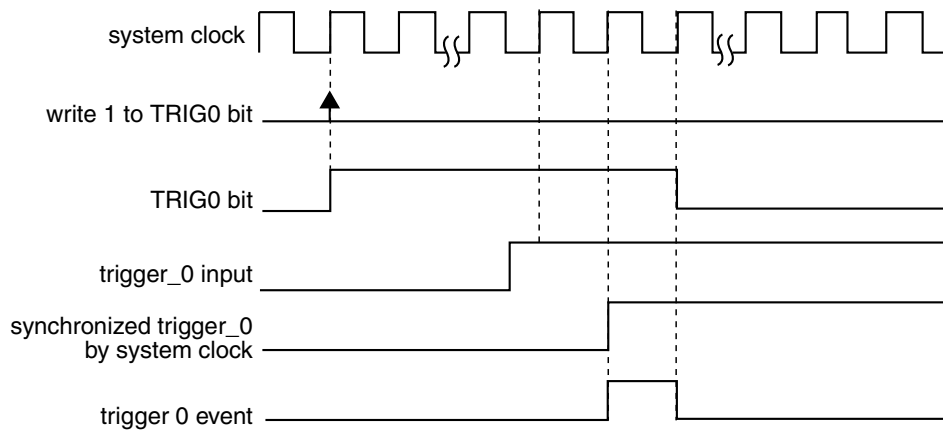

Note
All hardware trigger inputs have the same behavior.

Figure 36-205. Hardware Trigger Event with HWTRIGMODE = 0

If HWTRIGMODE = 1 then the TRIGn bit is only cleared when 0 is written to it.

NOTE

It is expected that the HWTRIGMODE bit be 1 only with enhanced PWM synchronization (SYNCMODE = 1).

36.4.11.2 Software Trigger

A software trigger event occurs when 1 is written to the SYNC[SWSYNC] bit. The SWSYNC bit is cleared when 0 is written to it or when the PWM synchronization (initiated by the software event) is completed.

If a new software trigger event occurs (write 1 to SWSYNC bit) together with the end of the previous synchronization (also initiated by the software trigger event) then this new synchronization is started and SWSYNC bit remains equal to 1.

If SYNCMODE = 0 then the SWSYNC bit is also cleared by FTM according to PWMSYNC and REINIT bits. In this case if (PWMSYNC = 1) or (PWMSYNC = 0 and REINIT = 0) then SWSYNC bit is cleared at the next selected loading point ([Boundary Cycle and Loading Points](#)) after that the software trigger event occurred (see the following figure). If (PWMSYNC = 0) and (REINIT = 1) then SWSYNC bit is cleared when the software trigger event occurs.

If SYNCMODE = 1 then the SWSYNC bit is also cleared by FTM according to the SWRSTCNT bit. If SWRSTCNT = 0 then SWSYNC bit is cleared at the next selected loading point after that the software trigger event occurred (see the following figure). If SWRSTCNT = 1 then SWSYNC bit is cleared when the software trigger event occurs.

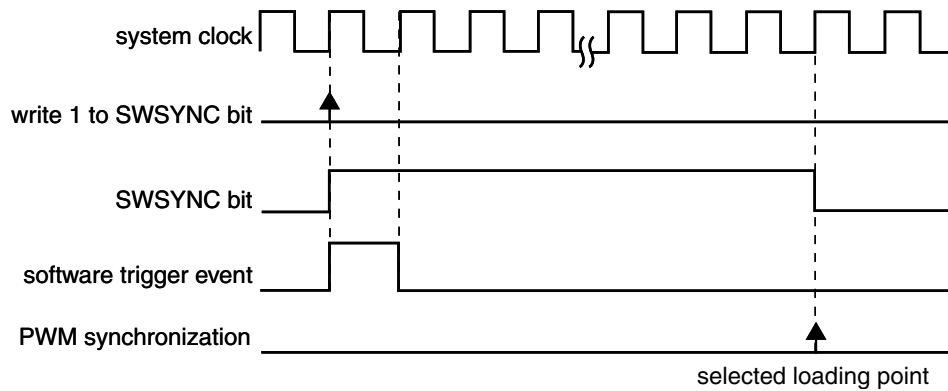

Figure 36-206. Software Trigger Event

36.4.11.3 Boundary Cycle and Loading Points

The boundary cycle definition is important for the loading points for the registers MOD, CNTIN and C(n)V.

In up counting mode ([Up Counting](#)) the boundary cycle is defined as when the counter wraps to its initial value (CNTIN). If in up-down counting mode ([Up-Down Counting](#)) then the boundary cycle is defined as when the counter turns from down to up counting and when from up to down counting.

The following figure shows the boundary cycles and the loading points. In the up counting mode, the loading points are enabled if one of CNTMIN or CTMAX bits are 1. In the up-down counting mode, the loading points are selected by CNTMIN and CNTMAX bits, as indicated in the figure. These loading points are safe places for register updates thus allowing a smooth transitions in PWM waveform generation.

For both counting modes if neither CNTMIN nor CNTMAX are 1 then the boundary cycles are not used as loading points for registers updates. See the register synchronization descriptions in the following sections for details.

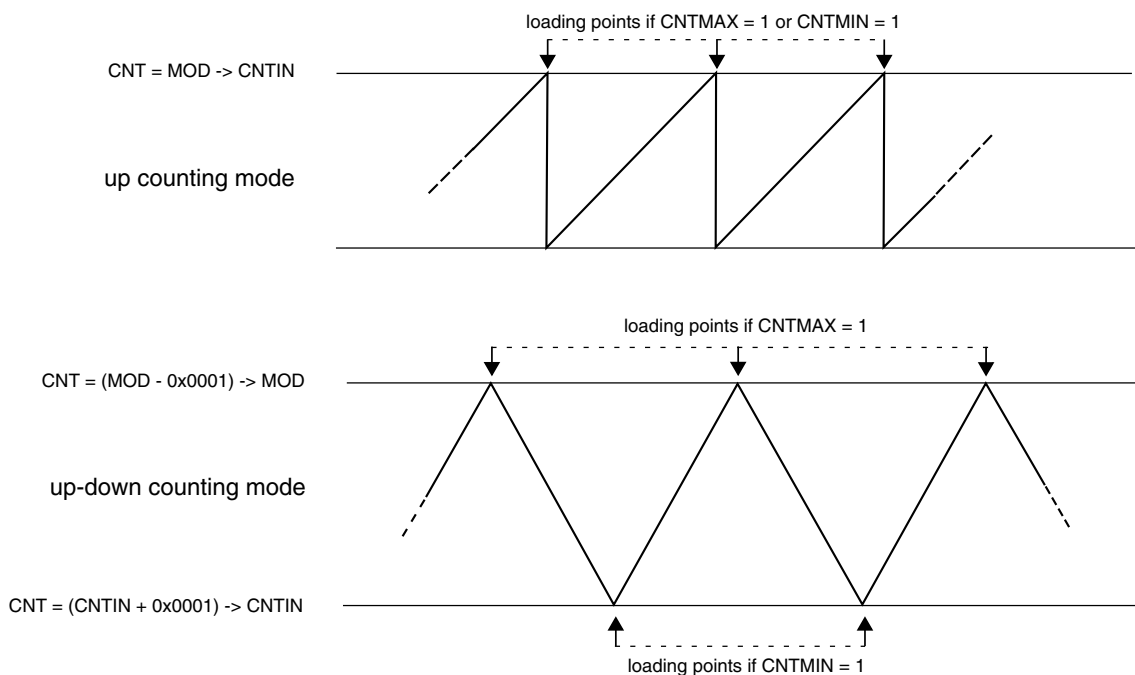

Figure 36-207. Boundary Cycles and Loading Points

36.4.11.4 MOD Register Synchronization

The MOD register synchronization updates the MOD register with its buffer value. This synchronization is enabled if (FTMEN = 1).

The MOD register synchronization can be done by either the enhanced PWM synchronization (SYNCMODE = 1) or the legacy PWM synchronization (SYNCMODE = 0). However, it is expected that the MOD register be synchronized only by the enhanced PWM synchronization.

In the case of enhanced PWM synchronization, the MOD register synchronization depends on SWWRBUF, SWRSTCNT, HWWRBUF and HWRSTCNT bits according to this flowchart:

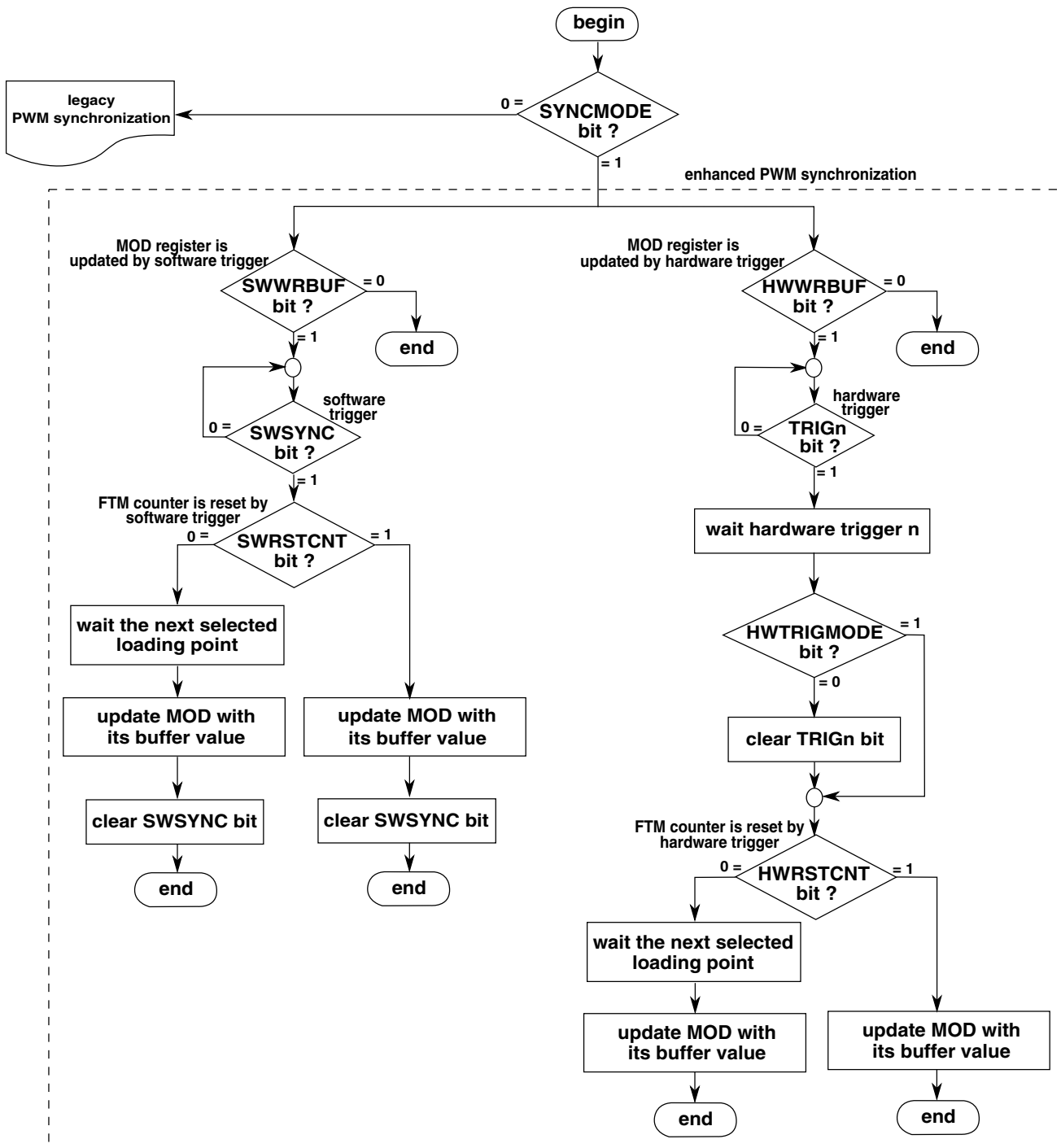

Figure 36-208. MOD Register Synchronization Flowchart

In the case of legacy PWM synchronization, the MOD register synchronization depends on PWMSYNC and REINIT bits according to the following description.

If (SYNCMODE = 0), (PWMSYNC = 0) and (REINIT = 0) then this synchronization is made on the next selected loading point after an enabled trigger event takes place. If the trigger event was a software trigger then the SWSYNC bit is cleared on the next selected

Functional Description

loading point. If the trigger event was a hardware trigger then the trigger enable bit (TRIGN) is cleared according to [Hardware Trigger](#). Examples with software and hardware triggers follow.

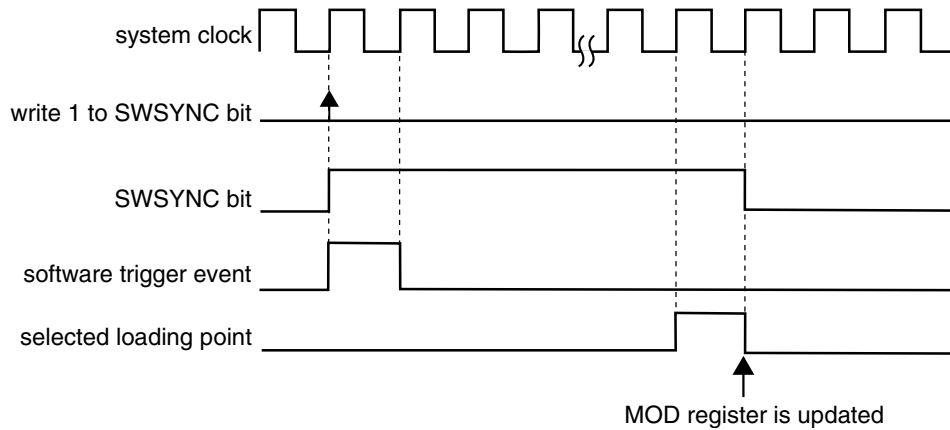

Figure 36-209. MOD Synchronization with (SYNCMODE = 0), (PWMSYNC = 0), (REINIT = 0), and (Software Trigger Was Used)

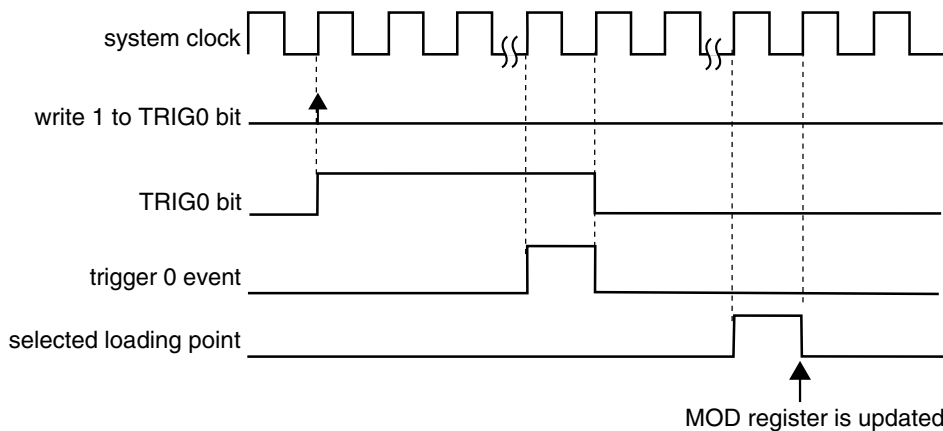

Figure 36-210. MOD Synchronization with (SYNCMODE = 0), (HWTRIGMODE = 0), (PWMSYNC = 0), (REINIT = 0), and (a Hardware Trigger Was Used)

If (SYNCMODE = 0), (PWMSYNC = 0) and (REINIT = 1) then this synchronization is made on the next enabled trigger event. If the trigger event was a software trigger then the SWSYNC bit is cleared according to the following example. If the trigger event was a hardware trigger then the TRIGN bit is cleared according to [Hardware Trigger](#). Examples with software and hardware triggers follow.

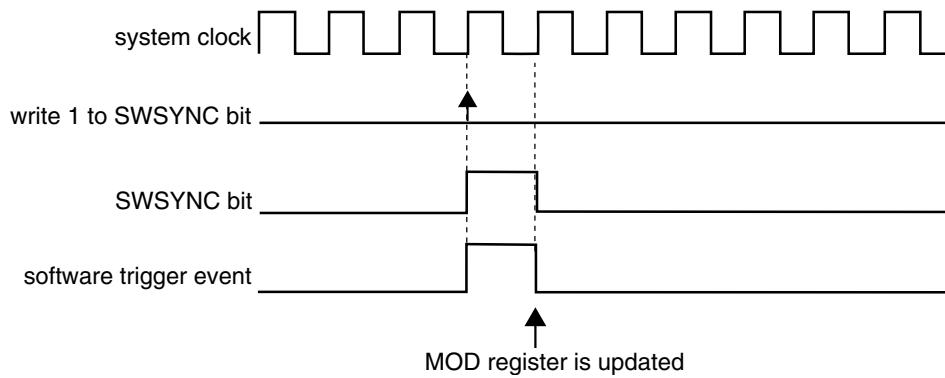

Figure 36-211. MOD Synchronization with (SYNCMODE = 0), (PWMSYNC = 0), (REINIT = 1), and (Software Trigger Was Used)

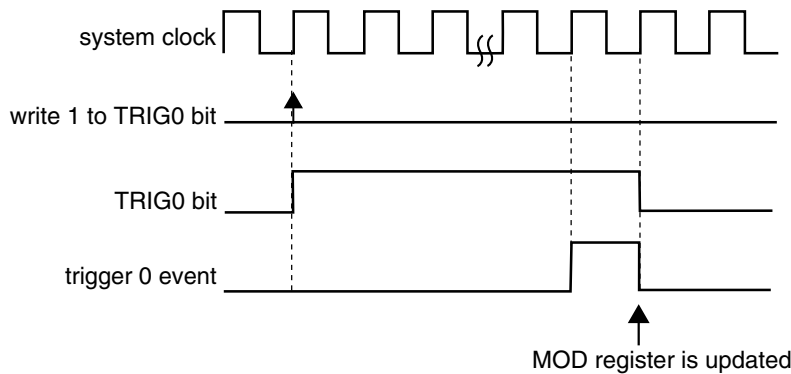

Figure 36-212. MOD Synchronization with (SYNCMODE = 0), (HWTRIGMODE = 0), (PWMSYNC = 0), (REINIT = 1), and (a Hardware Trigger Was Used)

If (SYNCMODE = 0) and (PWMSYNC = 1) then this synchronization is made on the next selected loading point after the software trigger event takes place. The SWSYNC bit is cleared on the next selected loading point:

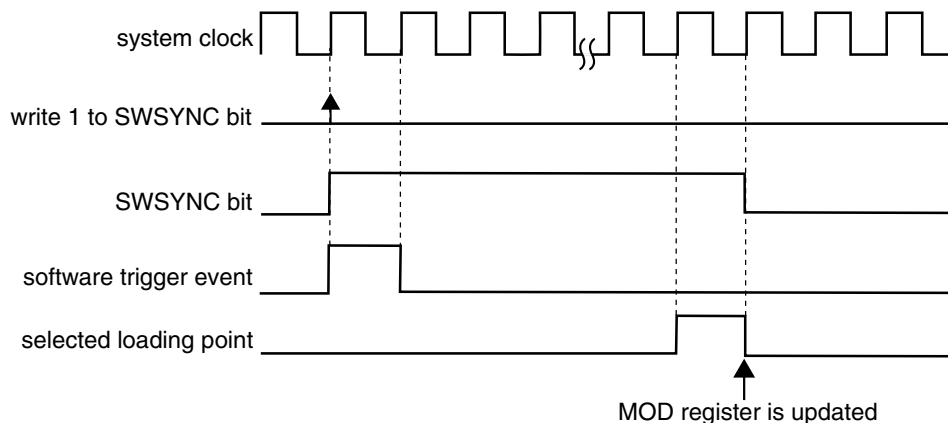

Figure 36-213. MOD Synchronization with (SYNCMODE = 0) and (PWMSYNC = 1)

36.4.11.5 CNTIN Register Synchronization

The CNTIN register synchronization updates the CNTIN register with its buffer value.

This synchronization is enabled if (FTMEN = 1), (SYNCMODE = 1) and (CNTINC = 1). The CNTIN register synchronization can be done only by the enhanced PWM synchronization (SYNCMODE = 1). The synchronization mechanism is the same as the MOD register synchronization done by the enhanced PWM synchronization ([MOD Register Synchronization](#)).

36.4.11.6 C(n)V and C(n+1)V Register Synchronization

The C(n)V and C(n+1)V registers synchronization updates the C(n)V and C(n+1)V registers with their buffer values.

This synchronization is enabled if (FTMEN = 1) and (SYNCEN = 1). The synchronization mechanism is the same as the MOD register synchronization ([MOD Register Synchronization](#)). However, it is expected that the C(n)V and C(n+1)V registers be synchronized only by the enhanced PWM synchronization (SYNCMODE = 1).

36.4.11.7 OUTMASK Register Synchronization

The OUTMASK register synchronization updates the OUTMASK register with its buffer value.

The OUTMASK register can be updated at each rising edge of system clock (SYNCHOM = 0), by the enhanced PWM synchronization (SYNCHOM = 1 and SYNCMODE = 1) or by the legacy PWM synchronization (SYNCHOM = 1 and SYNCMODE = 0). However, it is expected that the OUTMASK register be synchronized only by the enhanced PWM synchronization.

In the case of enhanced PWM synchronization, the OUTMASK register synchronization depends on SWOM and HWOM bits. See the following flowchart:

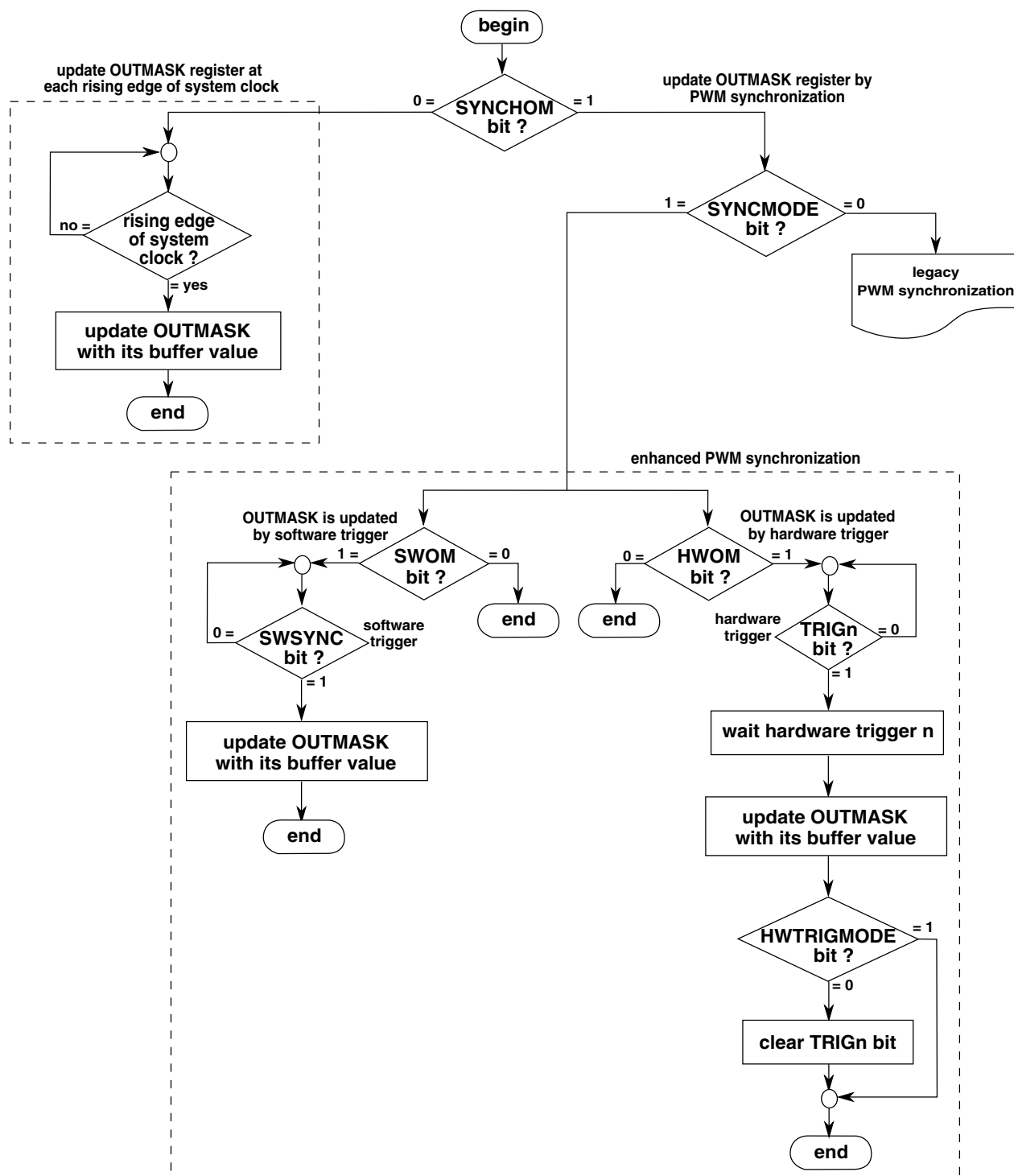

Figure 36-214. OUTMASK Register Synchronization Flowchart

In the case of legacy PWM synchronization, the OUTMASK register synchronization depends on PWMSYNC bit according to the following description.

If (SYNCMODE = 0), (SYNCHOM = 1) and (PWMSYNC = 0) then this synchronization is done on the next enabled trigger event. If the trigger event was a software trigger then the SWSYNC bit is cleared on the next selected loading point. If the trigger event was a hardware trigger then the TRIGN bit is cleared according to [Hardware Trigger](#). Examples with software and hardware triggers follow.

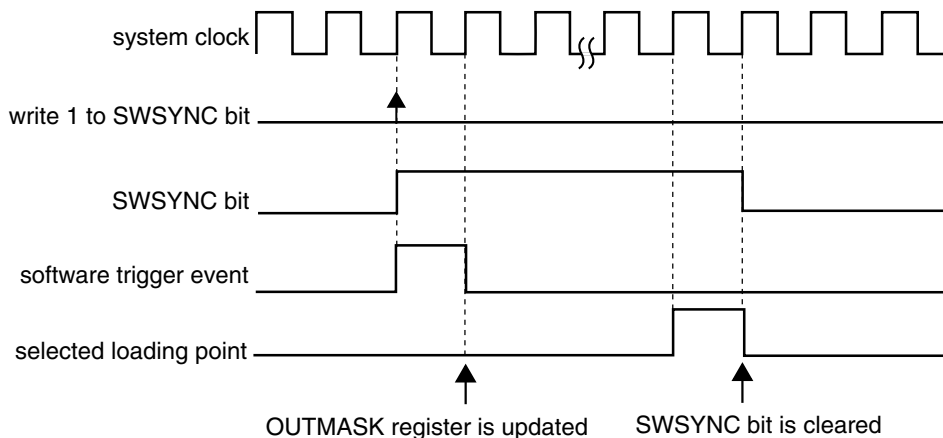

Figure 36-215. OUTMASK Synchronization with (SYNCMODE = 0), (SYNCHOM = 1), (PWMSYNC = 0) and (Software Trigger Was Used)

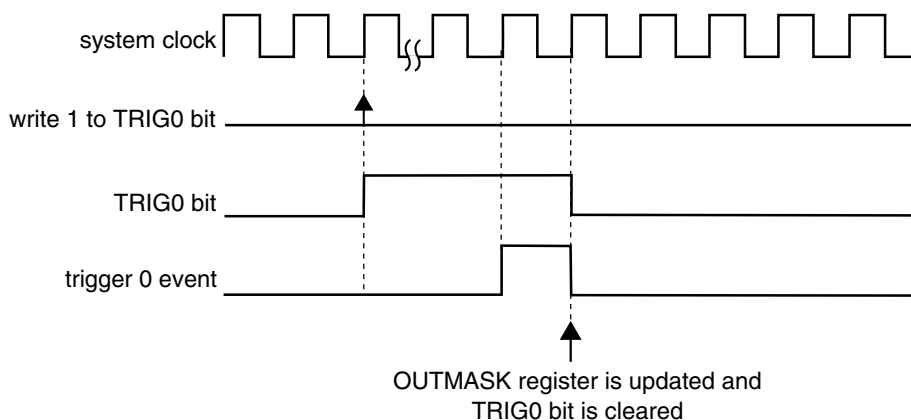

Figure 36-216. OUTMASK Synchronization with (SYNCMODE = 0), (HWTRIGMODE = 0), (SYNCHOM = 1), (PWMSYNC = 0), and (a Hardware Trigger Was Used)

If (SYNCMODE = 0), (SYNCHOM = 1) and (PWMSYNC = 1) then this synchronization is made on the next enabled hardware trigger. The TRIGN bit is cleared according to [Hardware Trigger](#). An example with a hardware trigger follows.

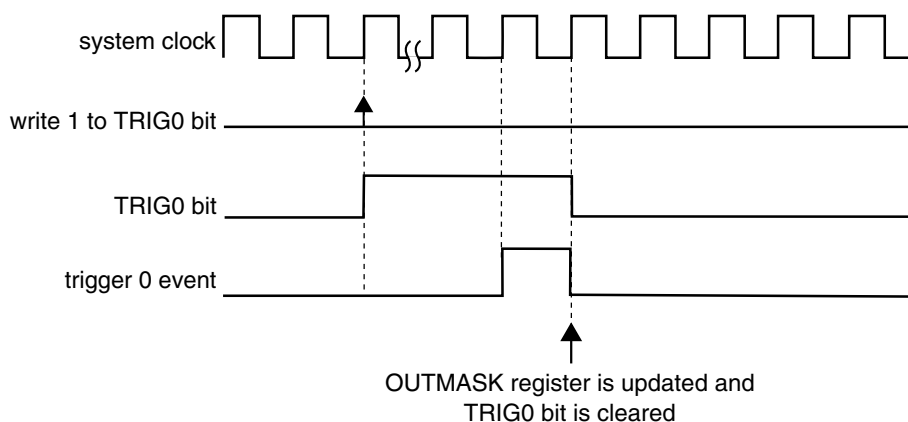

Figure 36-217. OUTMASK Synchronization with (SYNCMODE = 0), (HWTRIGMODE = 0), (SYNCHOM = 1), (PWMSYNC = 1), and (a Hardware Trigger Was Used)

36.4.11.8 INVCTRL Register Synchronization

The INVCTRL register synchronization updates the INVCTRL register with its buffer value.

The INVCTRL register can be updated at each rising edge of system clock (INVC = 0) or by the enhanced PWM synchronization (INVC = 1 and SYNCMODE = 1) according to the following flowchart.

In the case of enhanced PWM synchronization, the INVCTRL register synchronization depends on SWINVC and HWINVC bits.

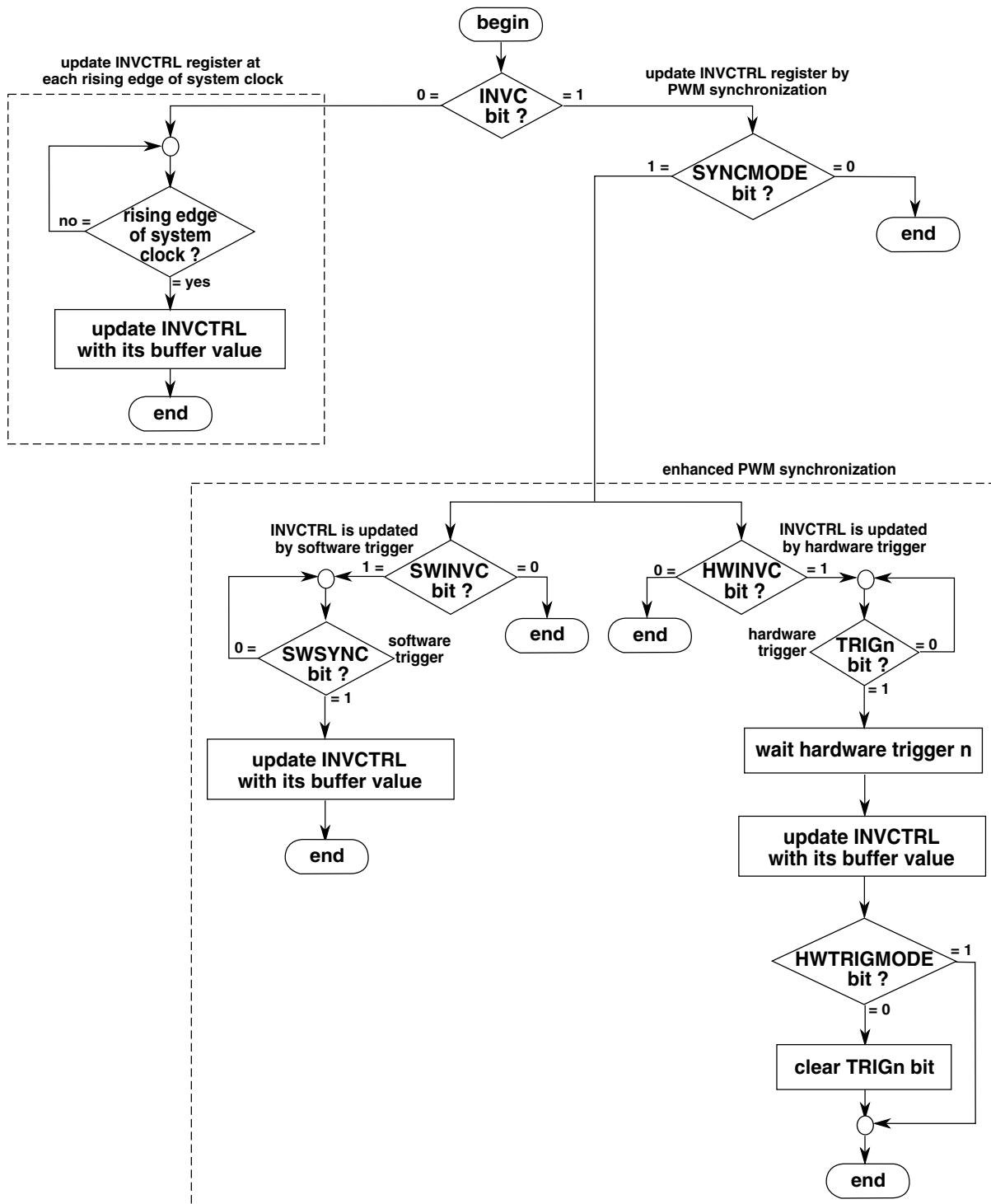

Figure 36-218. INVCTRL Register Synchronization Flowchart

36.4.11.9 SWOCTRL Register Synchronization

The SWOCTRL register synchronization updates the SWOCTRL register with its buffer value.

The SWOCTRL register can be updated at each rising edge of system clock (SWOC = 0) or by the enhanced PWM synchronization (SWOC = 1 and SYNCMODE = 1) according to the following flowchart.

In the case of enhanced PWM synchronization, the SWOCTRL register synchronization depends on SWSOC and HWSOC bits.

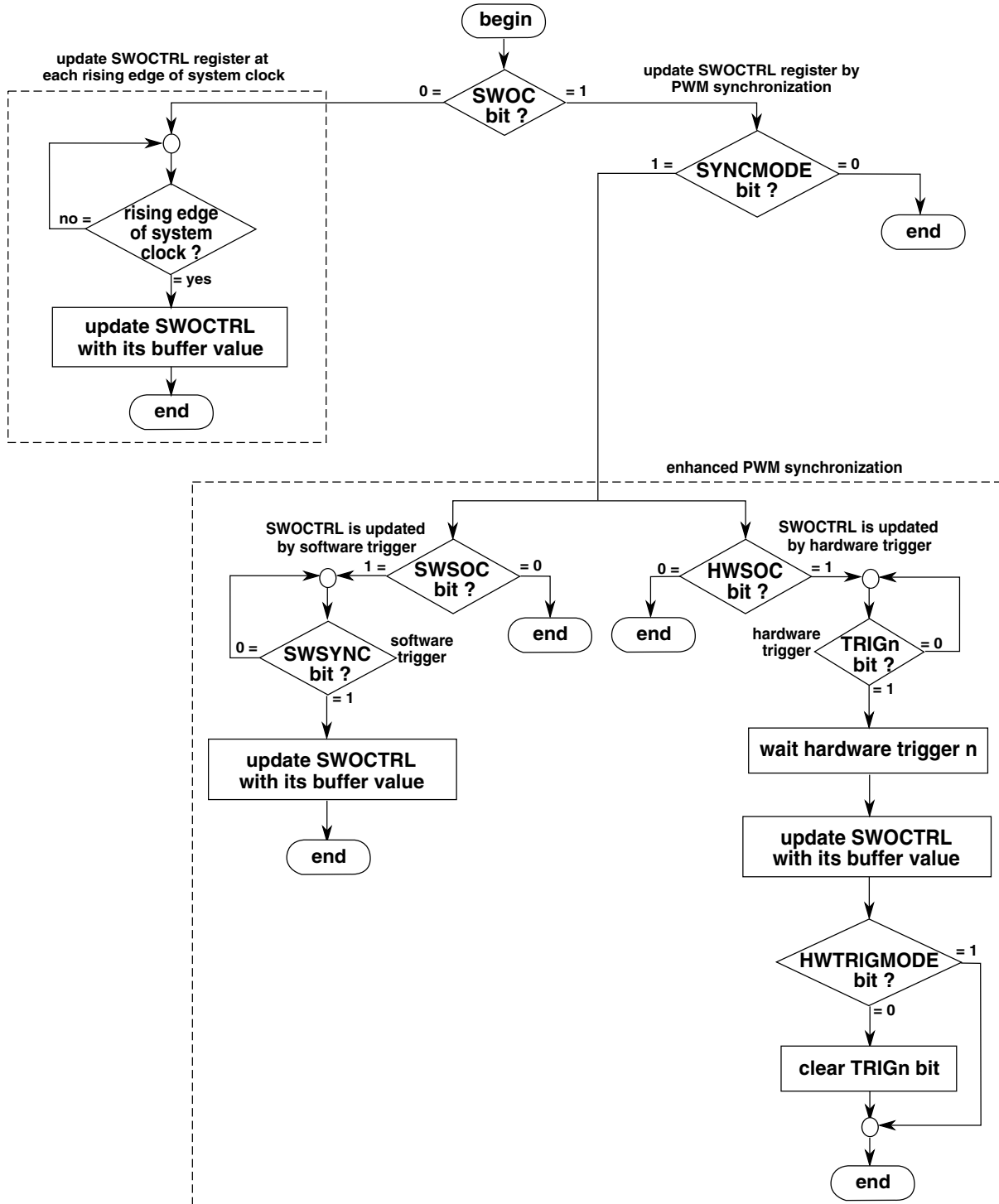

Figure 36-219. SWOCTRL Register Synchronization Flowchart

36.4.11.10 FTM Counter Synchronization

The FTM counter synchronization is a mechanism that allows the FTM to re-start the PWM generation at a certain point in the PWM period. The channels outputs are forced to their initial value (except for channels in output compare mode) and the FTM counter is forced to its initial counting value defined by CNTIN register.

The following figure shows the FTM counter synchronization. Note that after the synchronization event had occurred the channel (n) is set to its initial value and the channel (n+1) is not set to its initial value due to a specific timing of this figure in which the deadtime insertion prevents this channel output from transitioning to 1. If no deadtime insertion is selected then the channel (n+1) transitions to logical value 1 immediately after the synchronization event had occurred.

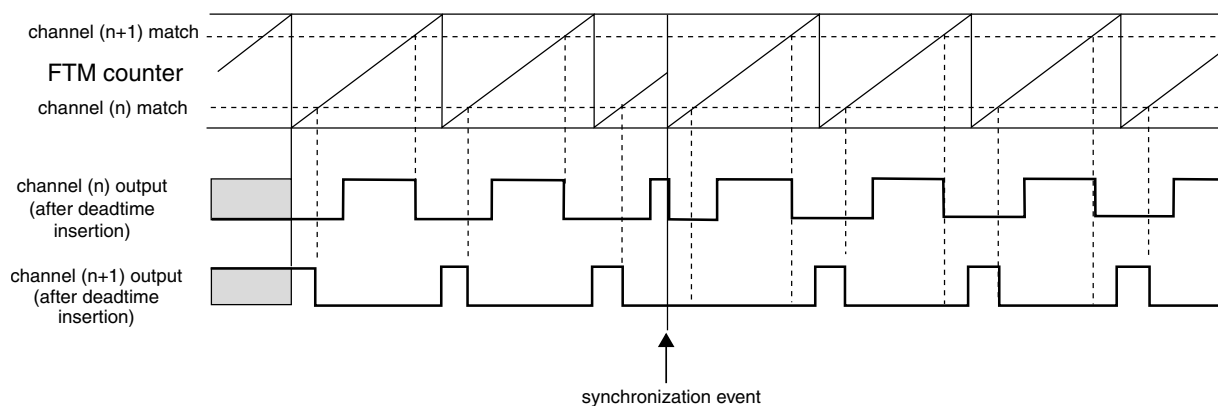

Figure 36-220. FTM Counter Synchronization

The FTM counter synchronization can be done by either the enhanced PWM synchronization (SYNCMODE = 1) or the legacy PWM synchronization (SYNCMODE = 0). However, it is expected that the FTM counter be synchronized only by the enhanced PWM synchronization.

In the case of enhanced PWM synchronization, the FTM counter synchronization depends on SWRSTCNT and HWRSTCNT bits according to the following flowchart.

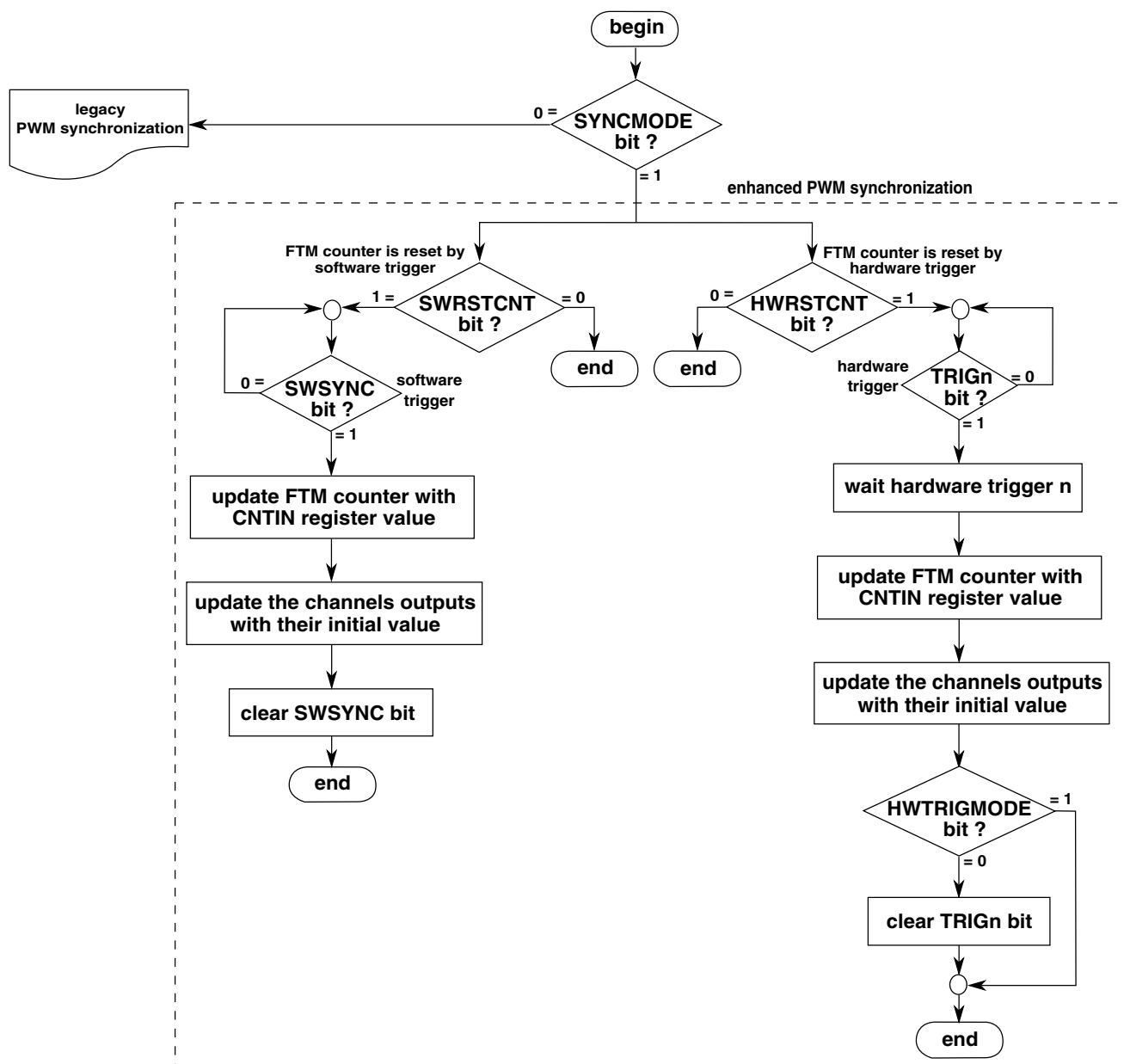

Figure 36-221. FTM Counter Synchronization Flowchart

In the case of legacy PWM synchronization, the FTM counter synchronization depends on REINIT and PWMSYNC bits according to the following description.

If (SYNCMODE = 0), (REINIT = 1) and (PWMSYNC = 0) then this synchronization is made on the next enabled trigger event. If the trigger event was a software trigger then the SWSYNC bit is cleared according to the following example. If the trigger event was a hardware trigger then the TRIGn bit is cleared according to [Hardware Trigger](#). Examples with software and hardware triggers follow.

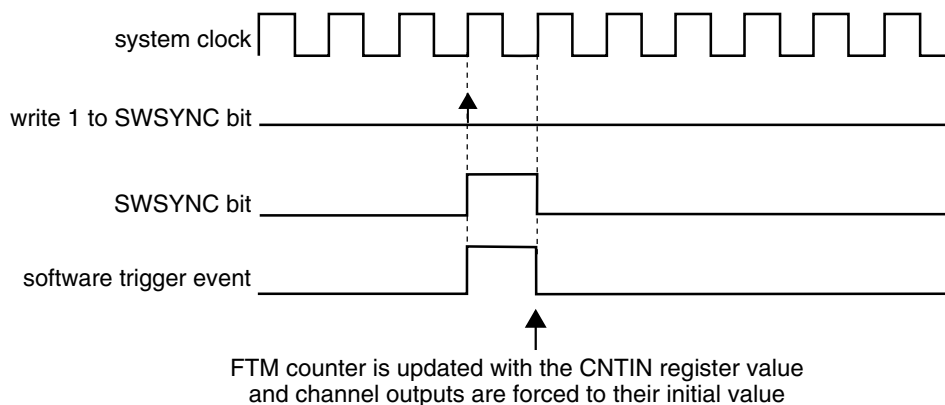

Figure 36-222. FTM Counter Synchronization with (SYNCMODE = 0), (REINIT = 1), (PWMSYNC = 0), and (Software Trigger Was Used)

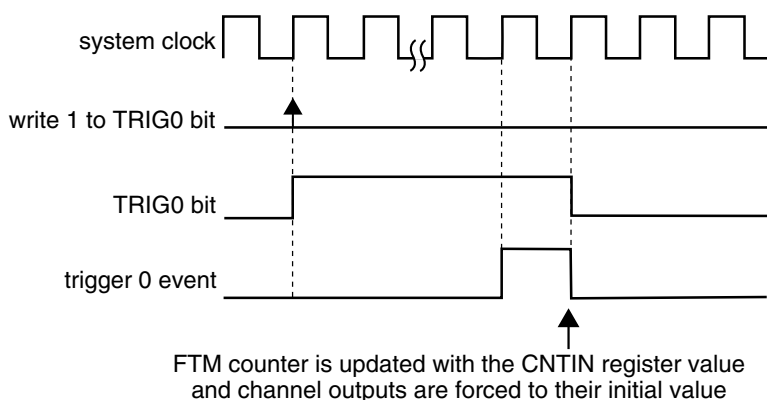

Figure 36-223. FTM Counter Synchronization with (SYNCMODE = 0), (HWTRIGMODE = 0), (REINIT = 1), (PWMSYNC = 0), and (a Hardware Trigger Was Used)

If (SYNCMODE = 0), (REINIT = 1) and (PWMSYNC = 1) then this synchronization is made on the next enabled hardware trigger. The TRIGn bit is cleared according to [Hardware Trigger](#).

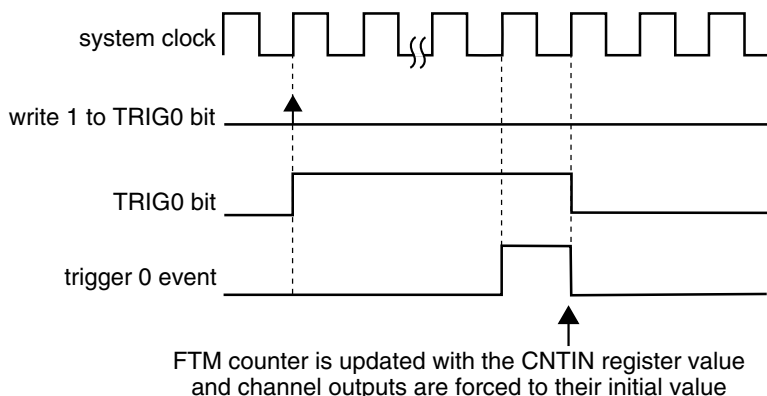

Figure 36-224. FTM Counter Synchronization with (SYNCMODE = 0), (HWTRIGMODE = 0), (REINIT = 1), (PWMSYNC = 1), and (a Hardware Trigger Was Used)

36.4.12 Inverting

The invert functionality swaps the signals between channel (n) and channel (n+1) outputs. The inverting operation is selected when (FTMEN = 1), (QUADEN = 0), (DECAPEN = 0), (COMBINE = 1), (COMP = 1), (CPWMS = 0), and (INVm = 1), where m represents a channel pair. The INVm bit in INVCTRL register is updated with its buffer value according to [INVCTRL Register Synchronization](#)

In high-true (ELSnB:ELSnA = 1:0) combine mode, the channel (n) output is forced low at the beginning of the period (FTM counter = CNTIN), forced high at the channel (n) match and forced low at the channel (n+1) match. If the inverting is selected, the channel (n) output behavior is changed to force high at the beginning of the PWM period, force low at the channel (n) match and force high at the channel (n+1) match. See the following figure.

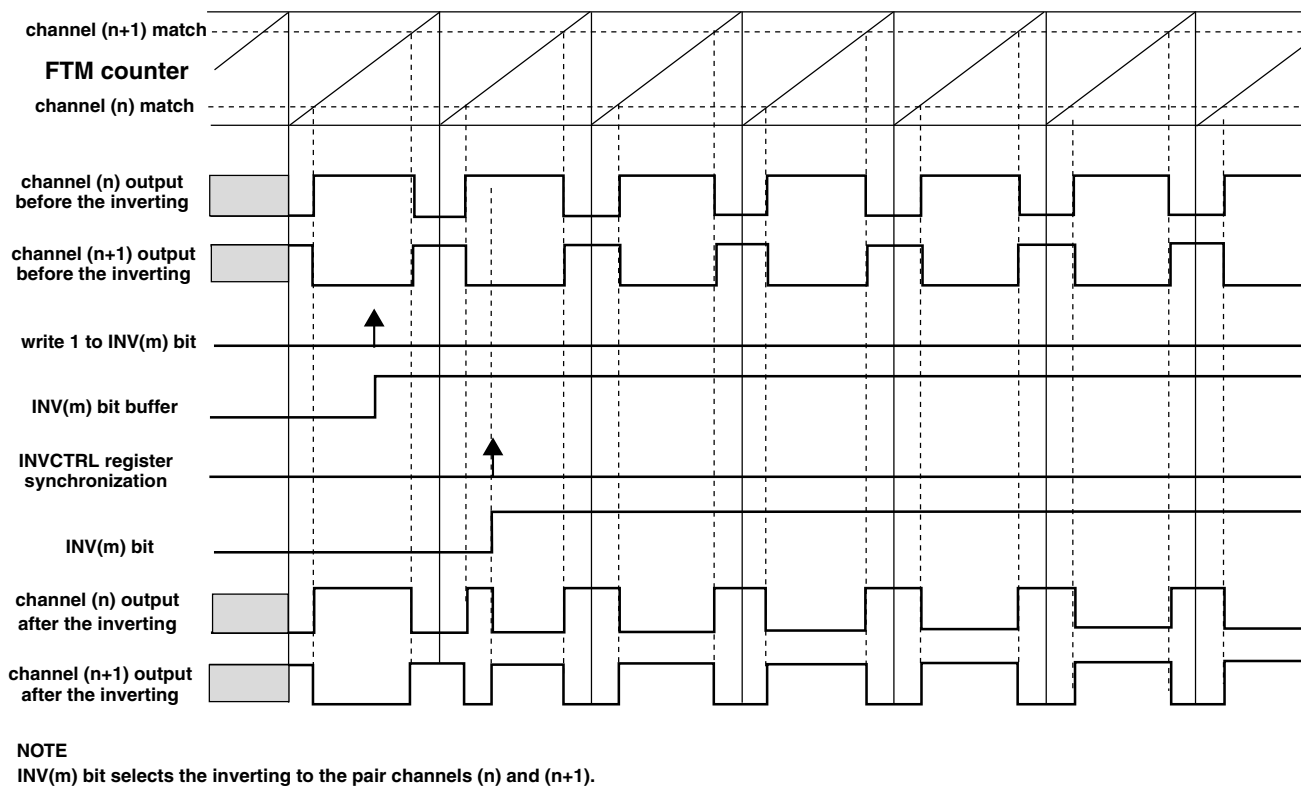
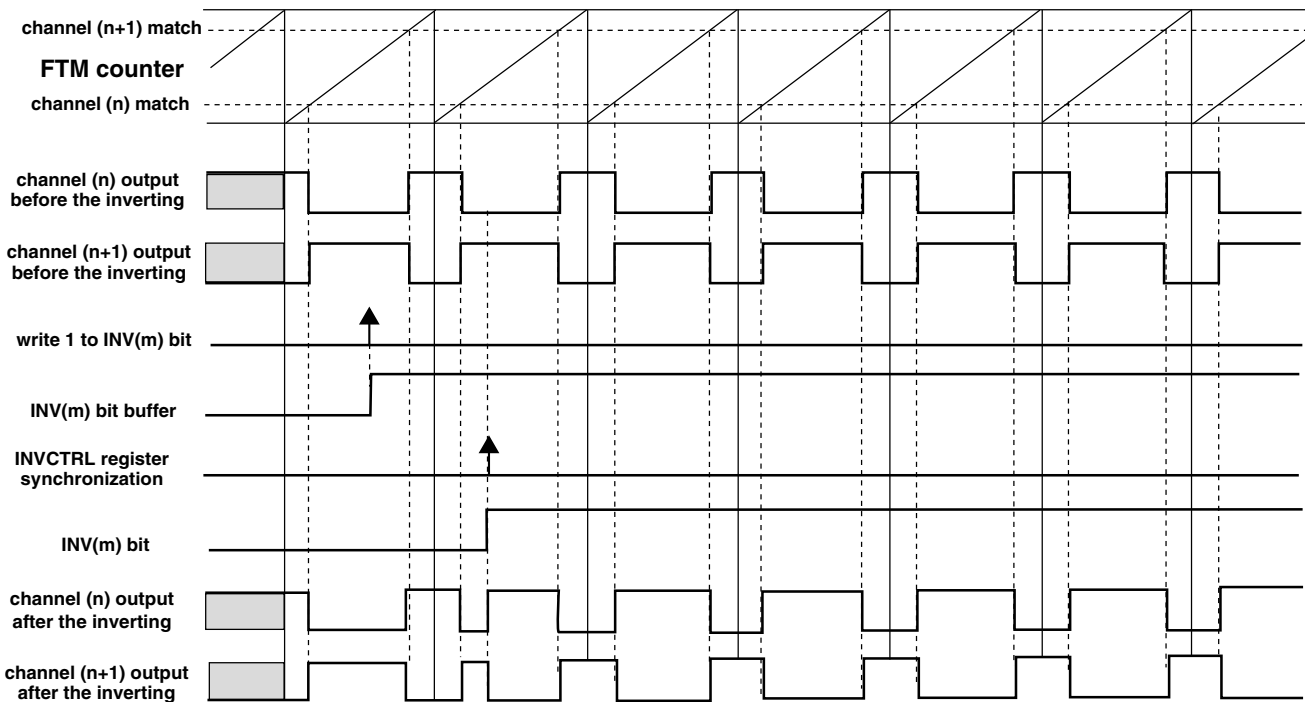

Figure 36-225. Channels (n) and (n+1) Outputs After the Inverting in High-True (ELSnB:ELSnA = 1:0) Combine Mode

Note that the ELSnB:ELSnA bits value should be consider since that they define the active state of the channels outputs. In low-true (ELSnB:ELSnA = X:1) combine mode, the channel (n) output is forced high at the beginning of the period, forced low at the channel (n) match and forced high at the channel (n+1) match. In the case the inverting is selected the channels (n) and (n+1) present waveforms as shown in the following figure.

Functional Description



NOTE

INV(m) bit selects the inverting to the pair channels (n) and (n+1).

Figure 36-226. Channels (n) and (n+1) Outputs After the Inverting in Low-True (ELSnB:ELSnA = X:1) Combine Mode

Note

It is expected that the inverting feature be used only in combine mode.

36.4.13 Software Output Control

The software output control forces the channel output according to software defined values at a specific time in the PWM generation.

The software output control is selected when (FTMEN = 1), (QUADEN = 0), (DECAPEN = 0), (COMBINE = 1), (CPWMS = 0), and (CHnOC = 1). The CHnOC bit enables the software output control for a specific channel output and the CHnOCV selects the value that is forced to this channel output.

Both CHnOC and CHnOCV bits in SWOCTRL register are buffered and updated with their buffer value according to [SWOCTRL Register Synchronization](#).

The following figure shows the channels (n) and (n+1) outputs signals when the software output control is used. In this case the channels (n) and (n+1) are set to combine and complementary mode.

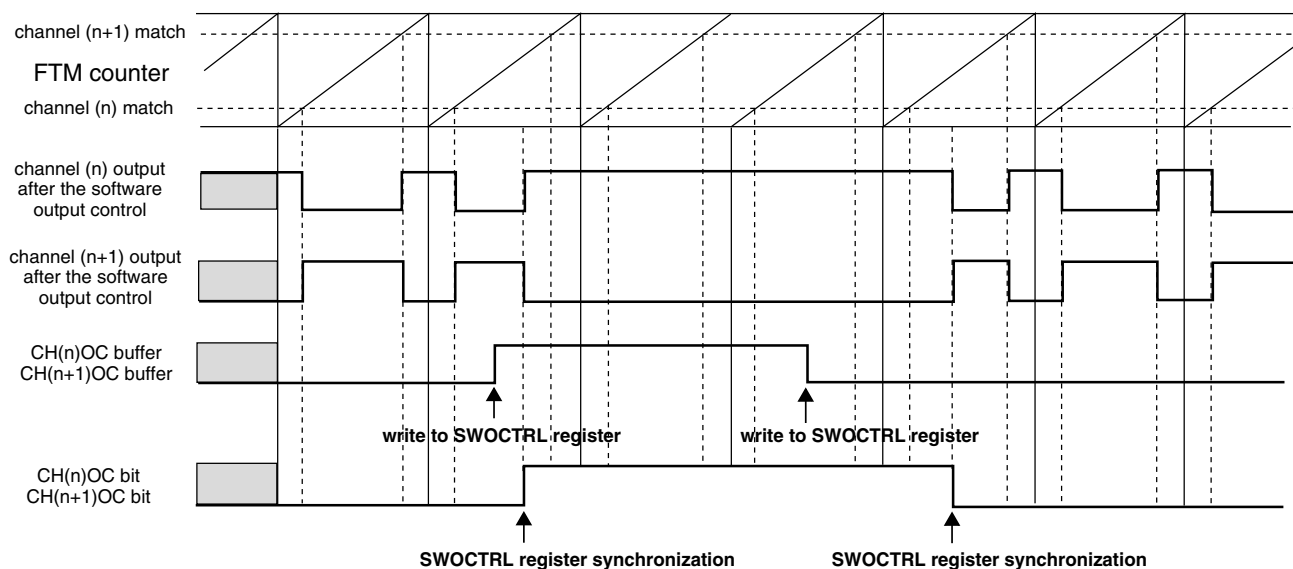

NOTE
CH(n)OCV = 1 and CH(n+1)OCV = 0.

Figure 36-227. Example of Software Output Control in Combine and Complementary Mode

Software output control forces the following values on channels (n) and (n+1) when the COMP bit is zero.

Table 36-242. Software Output Control Behavior when (COMP = 0)

CH(n)OC	CH(n+1)OC	CH(n)OCV	CH(n+1)OCV	Channel (n) Output	Channel (n+1) Output
0	0	X	X	is not modified by SWOC	is not modified by SWOC
1	1	0	0	is forced to zero	is forced to zero
1	1	0	1	is forced to zero	is forced to one
1	1	1	0	is forced to one	is forced to zero
1	1	1	1	is forced to one	is forced to one

Software output control forces the following values on channels (n) and (n+1) when the COMP bit is one.

Table 36-243. Software Output Control Behavior when (COMP = 1)

CH(n)OC	CH(n+1)OC	CH(n)OCV	CH(n+1)OCV	Channel (n) Output	Channel (n+1) Output
0	0	X	X	is not modified by SWOC	is not modified by SWOC
1	1	0	0	is forced to zero	is forced to zero
1	1	0	1	is forced to zero	is forced to one
1	1	1	0	is forced to one	is forced to zero
1	1	1	1	is forced to one	is forced to zero

Note

- It is expected that the software output control feature be used only in combine mode.
- The CH(n)OC and CH(n+1)OC bits should be equal.
- The COMP bit should not be modified when software output control is enabled, that is, CH(n)OC = 1 and/or CH(n+1)OC = 1.
- Software output control has the same behavior with disabled or enabled FTM counter (see the CLKS bitfield description in the Status and Control register).

36.4.14 Deadtime Insertion

The deadtime insertion is enabled when (DTEN = 1) and (DTVAL[5:0] is non-zero).

DEADTIME register defines the deadtime delay that can be used for all FTM channels. The DTPS[1:0] bits define the prescaler for the system clock and the DTVAL[5:0] bits define the deadtime modulo (number of the deadtime prescaler clocks).

The deadtime delay insertion ensures that no two complementary signals (channels (n) and (n+1)) drive the active state at the same time.

If POL(n) = 0, POL(n+1) = 0, and the deadtime is enabled, then when the channel (n) match (FTM counter = C(n)V) occurs, the channel (n) output remains at the low value until the end of the deadtime delay when the channel (n) output is set. Similarly, when the channel (n+1) match (FTM counter = C(n+1)V) occurs, the channel (n+1) output remains at the low value until the end of the deadtime delay when the channel (n+1) output is set. See the following figures.

If POL(n) = 1, POL(n+1) = 1, and the deadtime is enabled, then when the channel (n) match (FTM counter = C(n)V) occurs, the channel (n) output remains at the high value until the end of the deadtime delay when the channel (n) output is cleared. Similarly, when the channel (n+1) match (FTM counter = C(n+1)V) occurs, the channel (n+1) output remains at the high value until the end of the deadtime delay when the channel (n+1) output is cleared.

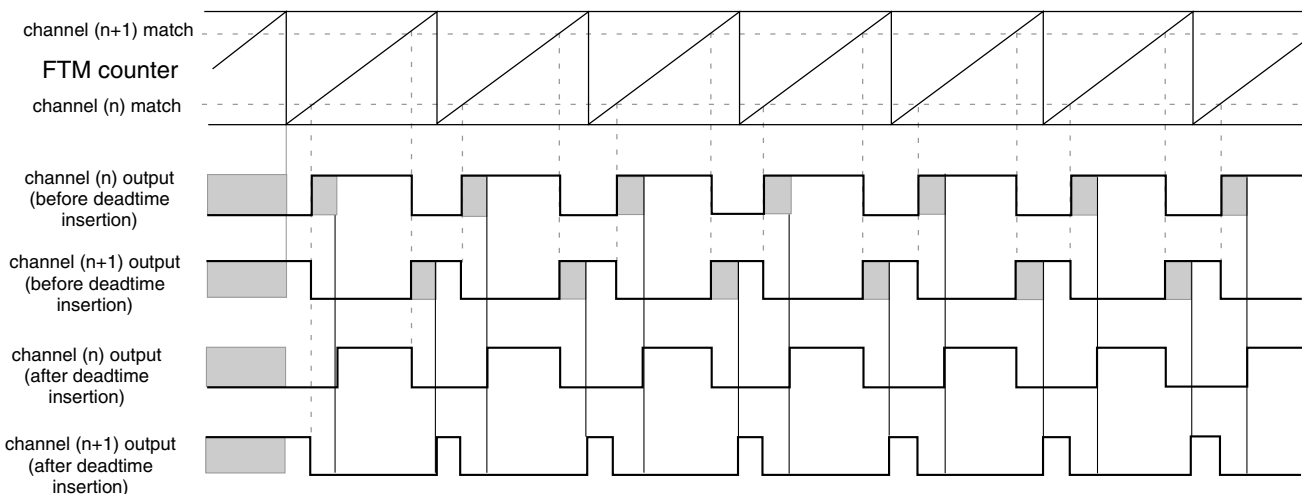

Figure 36-228. Deadtime Insertion with $ELSnB:ELSnA = 1:0$, $POL(n) = 0$, and $POL(n+1) = 0$

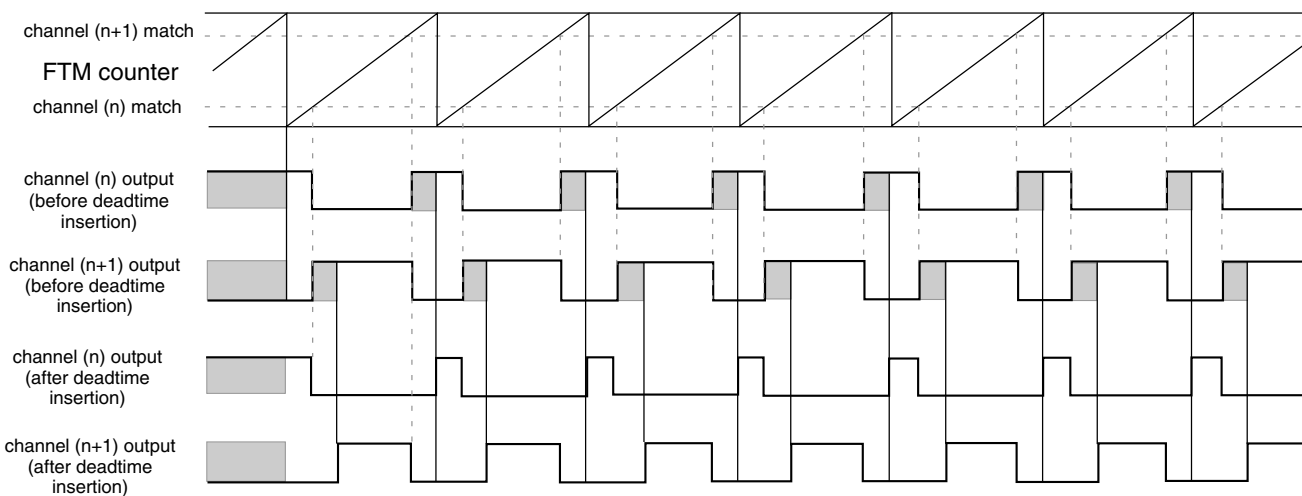

Figure 36-229. Deadtime Insertion with $ELSnB:ELSnA = X:1$, $POL(n) = 0$, and $POL(n+1) = 0$

NOTE

It is expected that the deadtime feature be used only in combine and complementary modes.

36.4.14.1 Deadtime Insertion Corner Cases

If (PS[2:0] is cleared), (DTPS[1:0] = 0:0 or DTPS[1:0] = 0:1):

Functional Description

- and the deadtime delay is greater than or equal to the channel (n) duty cycle ($((C(n+1)V - C(n)V) \times \text{system clock})$), then the channel (n) output is always the inactive value (POL(n) bit value).
- and the deadtime delay is greater than or equal to the channel (n+1) duty cycle ($((\text{MOD} - \text{CNTIN} + 1 - (C(n+1)V - C(n)V)) \times \text{system clock})$), then the channel (n+1) output is always the inactive value (POL(n+1) bit value).

Although, in most cases the deadtime delay is not comparable to channels (n) and (n+1) duty cycle, the following figures show examples where the deadtime delay is comparable to the duty cycle.

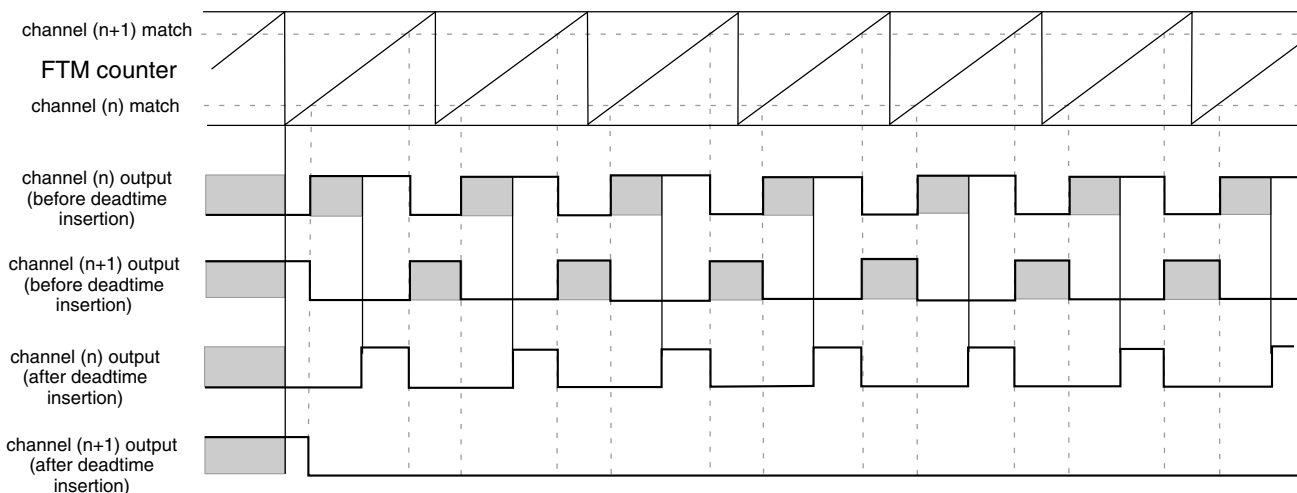

Figure 36-230. Example of the Deadtime Insertion (ELSnB:ELSnA = 1:0, POL(n) = 0, and POL(n+1) = 0) when the Deadtime Delay Is Comparable To Channel (n+1) Duty Cycle

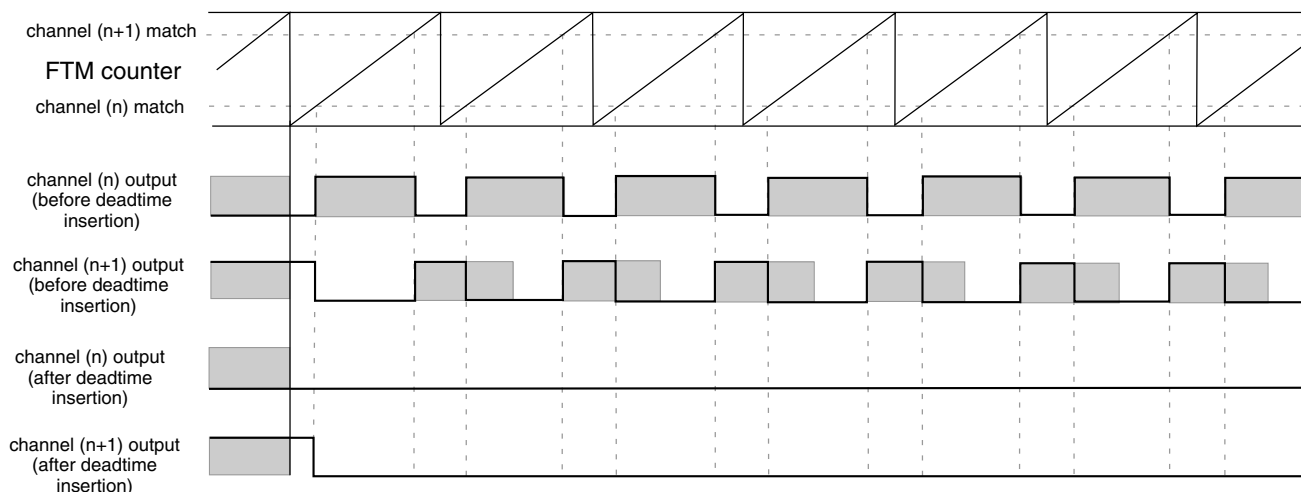

Figure 36-231. Example of the Deadtime Insertion (ELSnB:ELSnA = 1:0, POL(n) = 0, and POL(n+1) = 0) when the Deadtime Delay Is Comparable To Channels (n) and (n+1) Duty Cycle

36.4.15 Output Mask

The output mask can be used to force channels output to their inactive state through software (for example: to control a BLDC motor).

Any write to the OUTMASK register updates its write buffer. The OUTMASK register is updated with its buffer value by PWM synchronization ([OUTMASK Register Synchronization](#)).

If $CHnOM = 1$, then the channel (n) output is forced to its inactive state ($POLn$ bit value). If $CHnOM = 0$, then the channel (n) output is unaffected by the output mask (see the following figure).

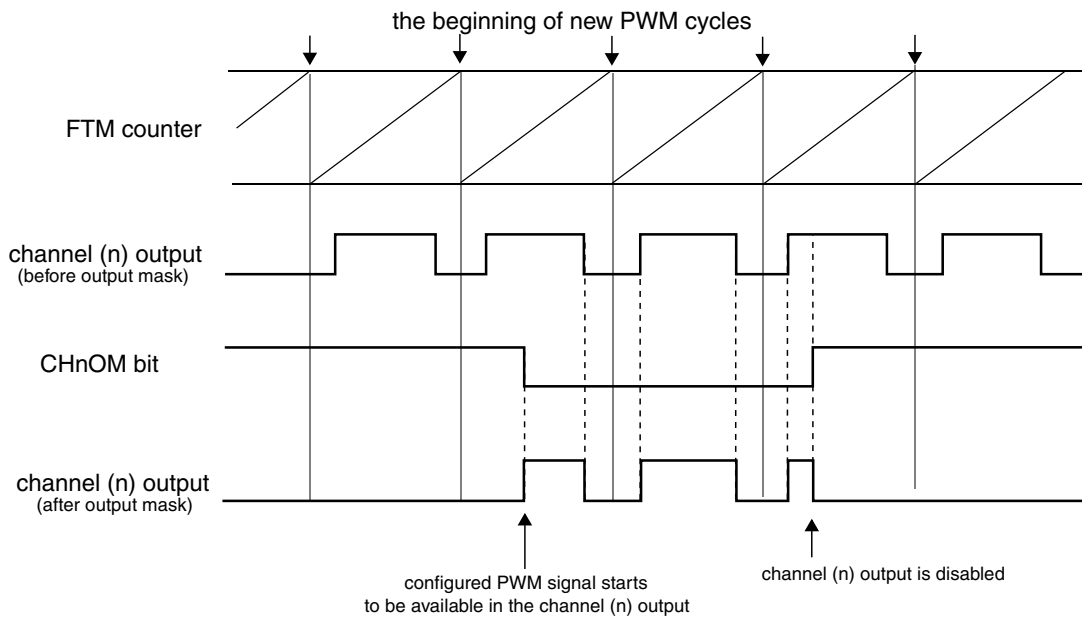

Figure 36-232. Output Mask with $POLn = 0$

The following table shows the output mask result before the polarity control.

Table 36-244. Output Mask Result for Channel (n) (Before the Polarity Control)

CHnOM	Output Mask Input	Output Mask Result
0	inactive state	inactive state
	active state	active state
1	inactive state	inactive state
	active state	

Note

It is expected the output mask feature be used only in combine mode.

36.4.16 Fault Control

The fault control is enabled if (FTMEN = 1) and (FAULTM[1:0] ≠ 0:0).

FTM can have up to four fault inputs. FAULTnEN bit (where n = 0, 1, 2, 3) enables the fault input n and FFLTRnEN bit enables the fault input n filter. FFVAL[3:0] bits select the value of the enabled filter in each enabled fault input.

First each fault input signal is synchronized by the system clock (see the synchronizer block in the following figure). Following synchronization, the fault input n signal enters the filter block. When there is a state change in the fault input n signal, the 5-bit counter is reset and starts counting up. As long as the new state is stable on the fault input n, the counter continues to increment. If the 5-bit counter overflows (the counter exceeds the value of the FFVAL[3:0] bits), the new fault input n value is validated. It is then transmitted as a pulse edge to the edge detector.

If the opposite edge appears on the fault input n signal before validation (counter overflow), the counter is reset. At the next input transition, the counter starts counting again. Any pulse that is shorter than the minimum value selected by FFVAL[3:0] bits (× system clock) is regarded as a glitch and is not passed on to the edge detector.

The fault input n filter is disabled when the FFVAL[3:0] bits are zero or when FAULTnEN = 0. In this case the fault input n signal is delayed 2 rising edges of the system clock and the FAULTFn bit is set on 3th rising edge of the system clock after a rising edge occurs on the fault input n.

If FFVAL[3:0] ≠ 0000 and FAULTnEN = 1, then the fault input n signal is delayed (3 + FFVAL[3:0]) rising edges of the system clock, that is, the FAULTFn bit is set (4 + FFVAL[3:0]) rising edges of the system clock after a rising edge occurs on the fault input n.

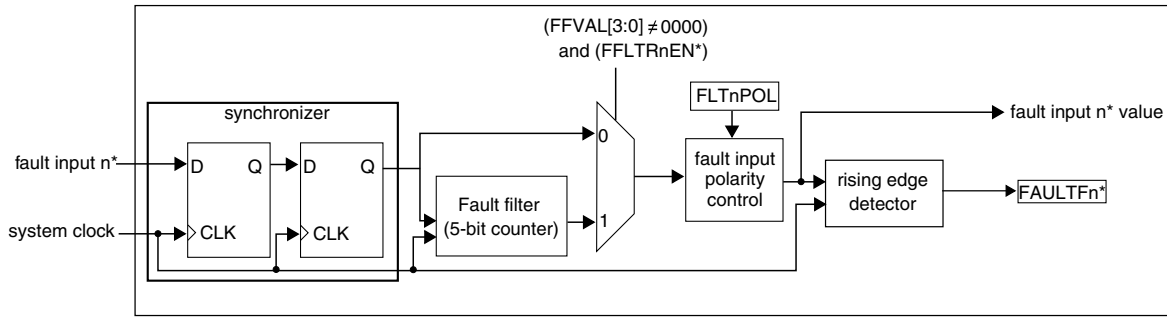

* where n = 3, 2, 1, 0

Figure 36-233. Fault Input n Control Block Diagram

If the fault control and fault input n are enabled and a rising edge at the fault input n signal is detected, then the FAULTFn bit is set. The FAULTF bit is the logic OR of FAULTFn[3:0] bits (see the following figure).

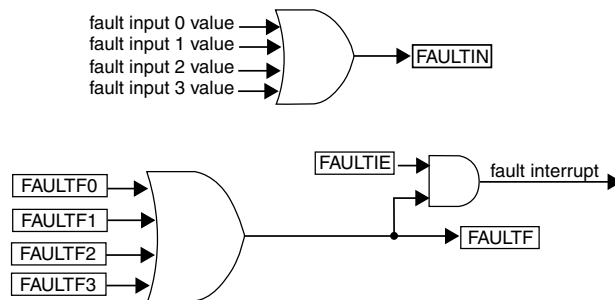

Figure 36-234. FAULTF and FAULTIN Bits and Fault Interrupt

If the fault control is enabled ($FAULTM[1:0] \neq 0:0$), a fault condition has occurred (rising edge at the logic OR of the enabled fault inputs) and ($FAULTEN = 1$), then channels (n) and (n+1) output are forced to their safe value (the channel (n) output is forced to the value of $POL(n)$ and the channel (n+1) is forced to the value of $POL(n+1)$).

The fault interrupt is generated when ($FAULTF = 1$) and ($FAULTIE = 1$). This interrupt request remains set until:

- Software clears the FAULTF bit (by reading FAULTF bit as 1 and writing 0 to it)
- Software clears the FAULTIE bit
- A reset occurs

Note

It is expected that the fault control be used only in combine mode.

36.4.16.1 Automatic Fault Clearing

If the automatic fault clearing is selected ($FAULTM[1:0] = 1:1$), then the channels output disabled by fault control is again enabled when the fault input signal ($FAULTIN$) returns to zero and a new PWM cycle begins (see the following figure).

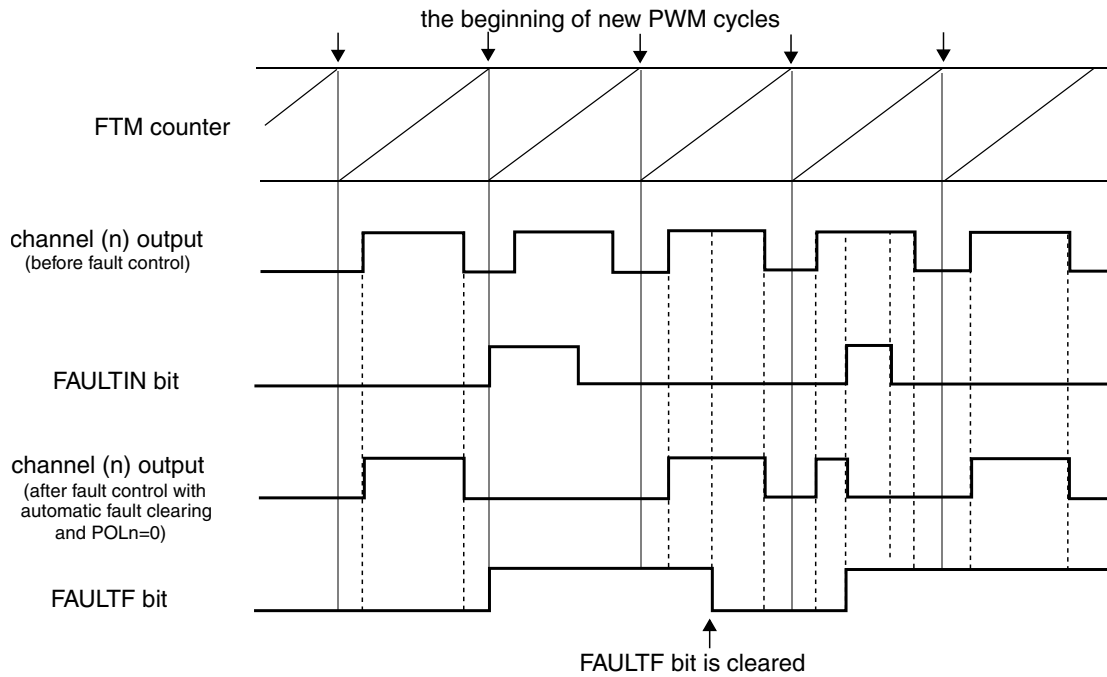

NOTE
The channel (n) output is after the fault control with automatic fault clearing and $POLn = 0$.

Figure 36-235. Fault Control with Automatic Fault Clearing

36.4.16.2 Manual Fault Clearing

If the manual fault clearing is selected ($FAULTM[1:0] = 0:1$ or $1:0$), then the channels output disabled by fault control is again enabled when the $FAULTF$ bit is cleared and a new PWM cycle begins (see the following figure).

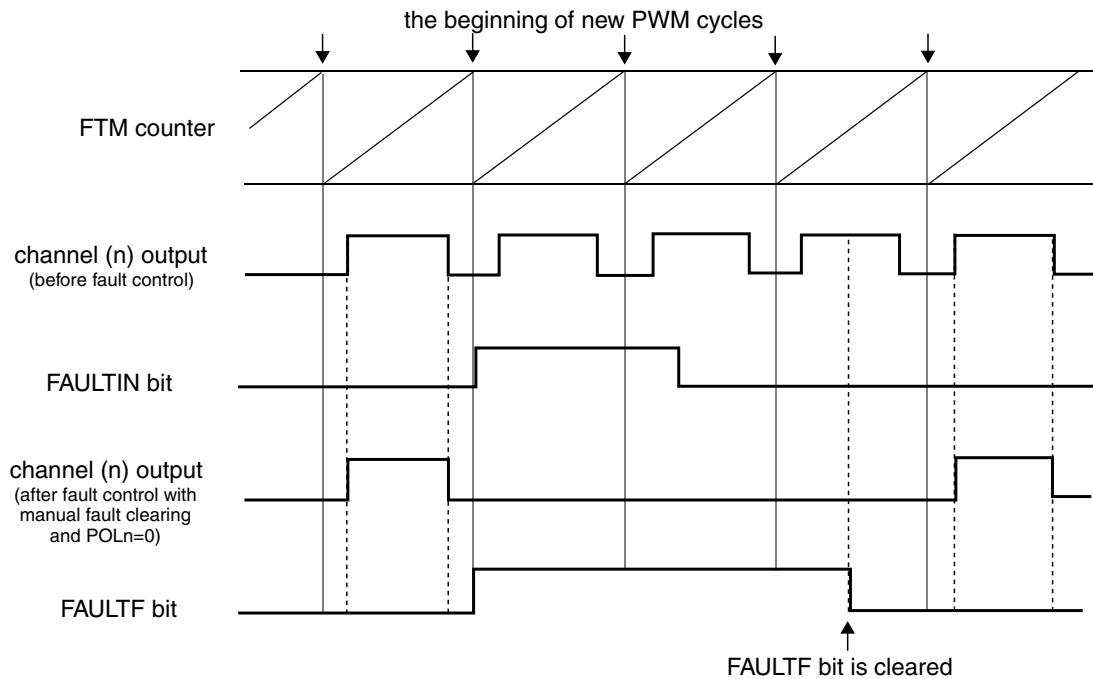

NOTE
The channel (n) output is after the fault control with manual fault clearing and $POL_n = 0$.

Figure 36-236. Fault Control with Manual Fault Clearing

36.4.16.3 Fault Inputs Polarity Control

The FLT_jPOL bit selects the fault input j polarity (where $j = 0, 1, 2, 3$).

- If $FLT_jPOL = 0$, the fault j input polarity is high, so the logical one at the fault input j indicates a fault.
- If $FLT_jPOL = 1$, the fault j input polarity is low, so the logical zero at the fault input j indicates a fault.

36.4.17 Polarity Control

The POL_n bit selects the channel (n) output polarity.

- If $POL_n = 0$, the channel (n) output polarity is high, so the logical one is the active state and the logical zero is the inactive state.
- If $POL_n = 1$, the channel (n) output polarity is low, so the logical zero is the active state and the logical one is the inactive state.

Note

It is expected that the polarity control be used only in combine mode.

36.4.18 Initialization

The initialization forces the CHnOI bit value to the channel (n) output when a one is written to the INIT bit.

The initialization depends on COMP and DTEN bits. The following table shows the values that channels (n) and (n+1) are forced by initialization when the COMP and DTEN bits are zero.

Table 36-245. Initialization Behavior when (COMP = 0 and DTEN = 0)

CH(n)OI	CH(n+1)OI	Channel (n) Output	Channel (n+1) Output
0	0	is forced to zero	is forced to zero
0	1	is forced to zero	is forced to one
1	0	is forced to one	is forced to zero
1	1	is forced to one	is forced to one

The following table shows the values that channels (n) and (n+1) are forced by initialization when (COMP = 1) or (DTEN = 1).

Table 36-246. Initialization Behavior when (COMP = 1 or DTEN = 1)

CH(n)OI	CH(n+1)OI	Channel (n) Output	Channel (n+1) Output
0	X	is forced to zero	is forced to one
1	X	is forced to one	is forced to zero

Note

It is expected that the initialization feature be used only in combine mode and with disabled FTM counter (see the description of the [CLKS](#) field in the Status and Control register).

36.4.19 Features Priority

The following figure shows the priority of the features used at the generation of channels (n) and (n+1) outputs signals.

pair channels (m) - channels (n) and (n+1)

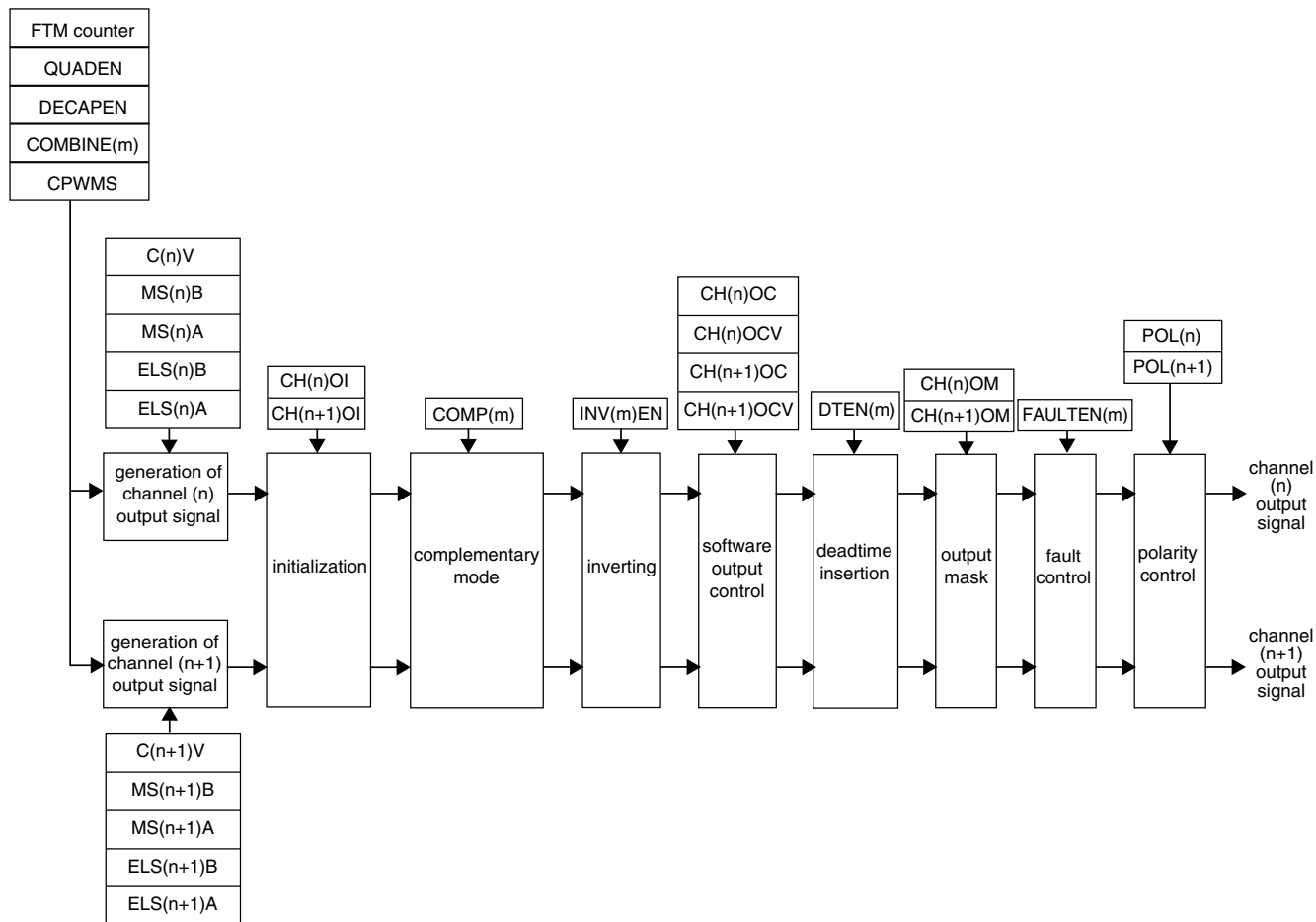

NOTE

The channels (n) and (n+1) are in output compare, EPWM, CPWM or combine modes.

Figure 36-237. Priority of the Features Used at the Generation of Channels (n) and (n+1) Outputs Signals

Note

It is expected that the initialization feature ([Initialization](#)) is not used with inverting ([Inverting](#)) and software output control ([Software Output Control](#)) features.

36.4.20 Channel Trigger Output

If CH_jTRIG = 1 (where j = 0, 1, 2, 3, 4, or 5), then the FTM generates a trigger when the channel (j) match occurs (FTM counter = C(j)V).

The channel trigger output provides a trigger signal that is used for on-chip modules.

The FTM is able to generate multiple triggers in one PWM period. Since each trigger is generated for a specific channel, several channels are required to implement this functionality. This behavior is described in the following figure.

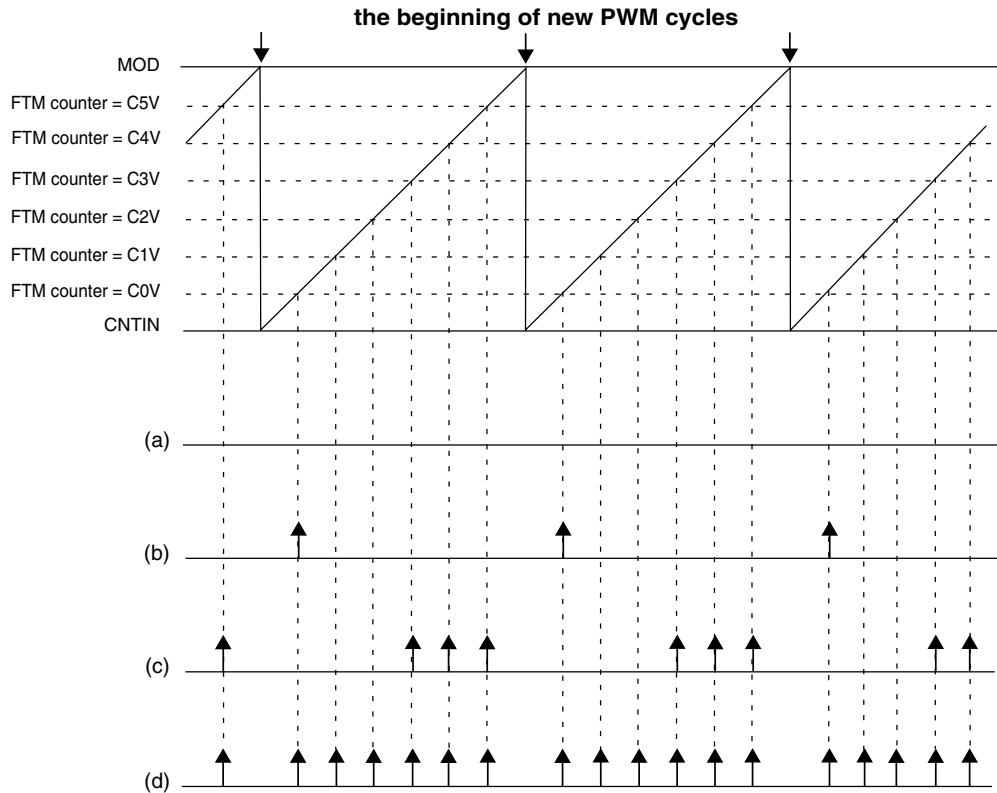

NOTE

- (a) CH0TRIG = 0, CH1TRIG = 0, CH2TRIG = 0, CH3TRIG = 0, CH4TRIG = 0, CH5TRIG = 0
- (b) CH0TRIG = 1, CH1TRIG = 0, CH2TRIG = 0, CH3TRIG = 0, CH4TRIG = 0, CH5TRIG = 0
- (c) CH0TRIG = 0, CH1TRIG = 0, CH2TRIG = 0, CH3TRIG = 1, CH4TRIG = 1, CH5TRIG = 1
- (d) CH0TRIG = 1, CH1TRIG = 1, CH2TRIG = 1, CH3TRIG = 1, CH4TRIG = 1, CH5TRIG = 1

Figure 36-238. Channel Match Trigger

Note

It is expected that the channel match trigger be used only in combine mode.

36.4.21 Initialization Trigger

If INITTRIGEN = 1, then the FTM generates a trigger when the FTM counter is updated with the CNTIN register value in the following cases.

- The FTM counter is automatically updated with the CNTIN register value by the selected counting mode.

- When there is a write to CNT register
- When there is the FTM counter synchronization ([FTM Counter Synchronization](#))
- If (CNT = CNTIN), (CLKS[1:0] = 0:0), and a value different from zero is written to CLKS[1:0] bits

The following figures show the cases.

CNTIN = 0x0000
 MOD = 0x000F
 CPWMS = 0

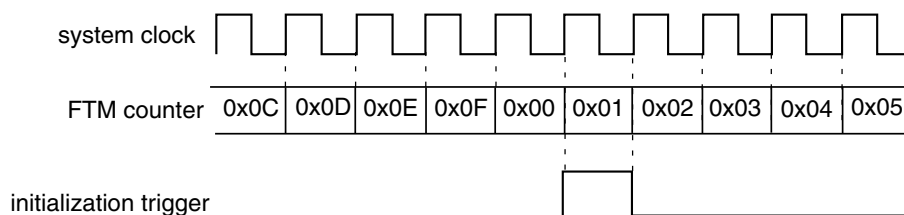

Figure 36-239. Initialization Trigger Is Generated When the FTM Counting Achieves the CNTIN Register Value

CNTIN = 0x0000
 MOD = 0x000F
 CPWMS = 0

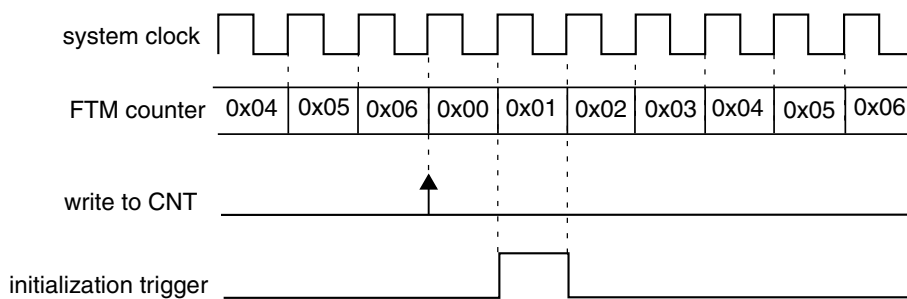

Figure 36-240. Initialization Trigger Is Generated When There Is a Write to CNT Register

CNTIN = 0x0000
 MOD = 0x000F
 CPWMS = 0

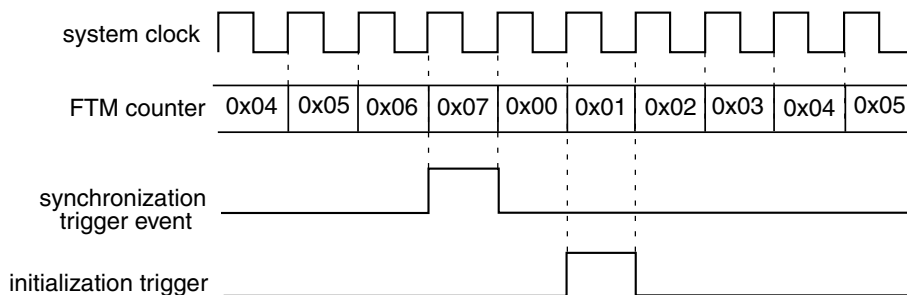

Figure 36-241. Initialization Trigger Is Generated When There Is the FTM Counter Synchronization

Functional Description

CNTIN = 0x0000
 MOD = 0x000F
 CPWMS = 0

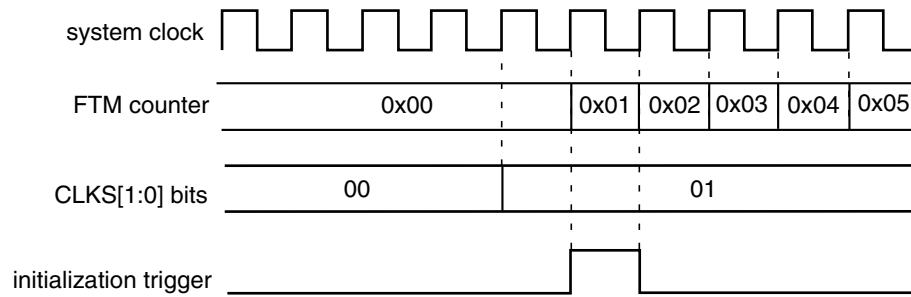

Figure 36-242. Initialization Trigger Is Generated If (CNT = CNTIN), (CLKS[1:0] = 0:0), and a Value Different From Zero Is Written to CLKS[1:0] Bits

The initialization trigger output provides a trigger signal that is used for on-chip modules.

Note

It is expected that the initialization trigger be used only in combine mode.

36.4.22 Capture Test Mode

The capture test mode allows to test the CnV registers, the FTM counter and the interconnection logic between the FTM counter and CnV registers.

In this test mode, all channels must be configured for input capture mode ([Input Capture Mode](#)) and FTM counter must be configured to the up counting ([Up Counting](#)).

When the capture test mode is enabled (CAPTEST = 1), the FTM counter is frozen and any write to CNT register updates directly the FTM counter (see the following figure). After it was written, all CnV registers are updated with the written value to CNT register and CHnF bits are set. Therefore, the FTM counter is updated with its next value according to its configuration (its next value depends on CNTIN, MOD, and the written value to FTM counter).

The next reads of CnV registers return the written value to the FTM counter and the next reads of CNT register return FTM counter next value.

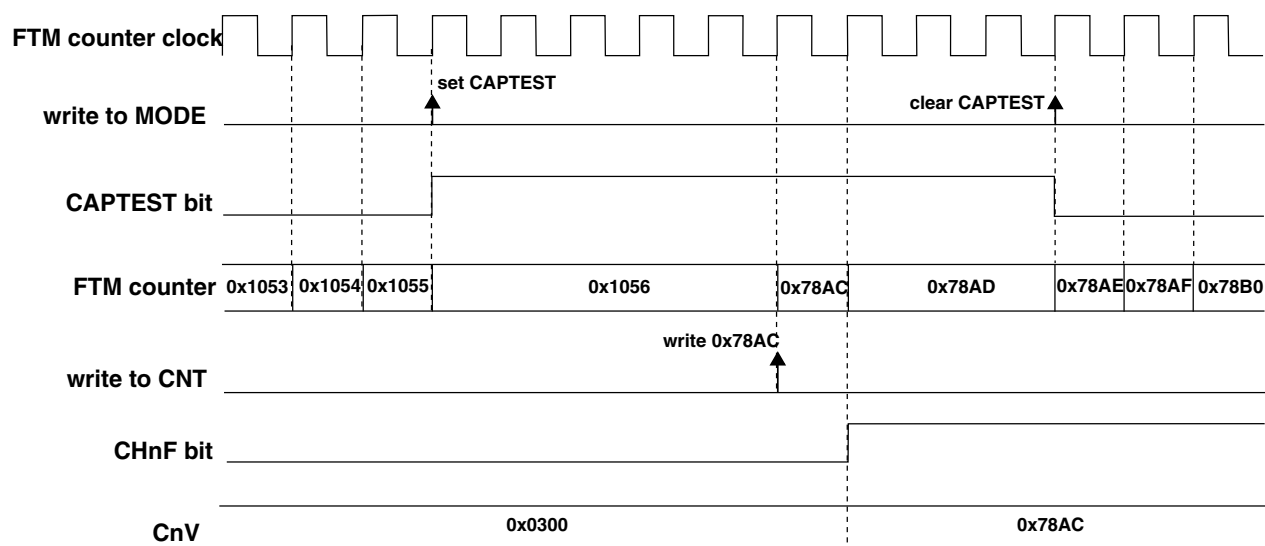
NOTE

- FTM counter configuration: (FTMEN = 1), (QUADEN = 0), (CAPTEST = 1), (CPWMS = 0), (CNTIN = 0x0000), and (MOD = 0xFFFF)
- FTM channel n configuration: input capture mode - (DECAPEN = 0), (COMBINE = 0), and (MSnB:MSnA = 0:0)

Figure 36-243. Capture Test Mode

36.4.23 DMA

The channel generates a DMA transfer request according to DMA and CHnIE bits (see the following table).

Table 36-247. Channel DMA Transfer Request

DMA	CHnIE	Channel DMA Transfer Request	Channel Interrupt
0	0	The channel DMA transfer request is not generated.	The channel interrupt is not generated.
0	1	The channel DMA transfer request is not generated.	The channel interrupt is generated if (CHnF = 1).
1	0	The channel DMA transfer request is not generated.	The channel interrupt is not generated.
1	1	The channel DMA transfer request is generated if (CHnF = 1).	The channel interrupt is not generated.

If DMA = 1, the CHnF bit is cleared either by channel DMA transfer done or reading CnSC while CHnF is set and then writing a zero to CHnF bit according to CHnIE bit (see the following table).

Table 36-248. Clear CHnF Bit when DMA = 1

CHnIE	How CHnF Bit Can Be Cleared
0	CHnF bit is cleared either when the channel DMA transfer is done or by reading CnSC while CHnF is set and then writing a 0 to CHnF bit.
1	CHnF bit is cleared when the channel DMA transfer is done.

36.4.24 Dual Edge Capture Mode

The dual edge capture mode is selected if FTMEN = 1 and DECAPEN = 1. This mode allows to measure a pulse width or period of the signal on the input of channel (n) of a channel pair. The channel (n) filter can be active in this mode when n is 0 or 2.

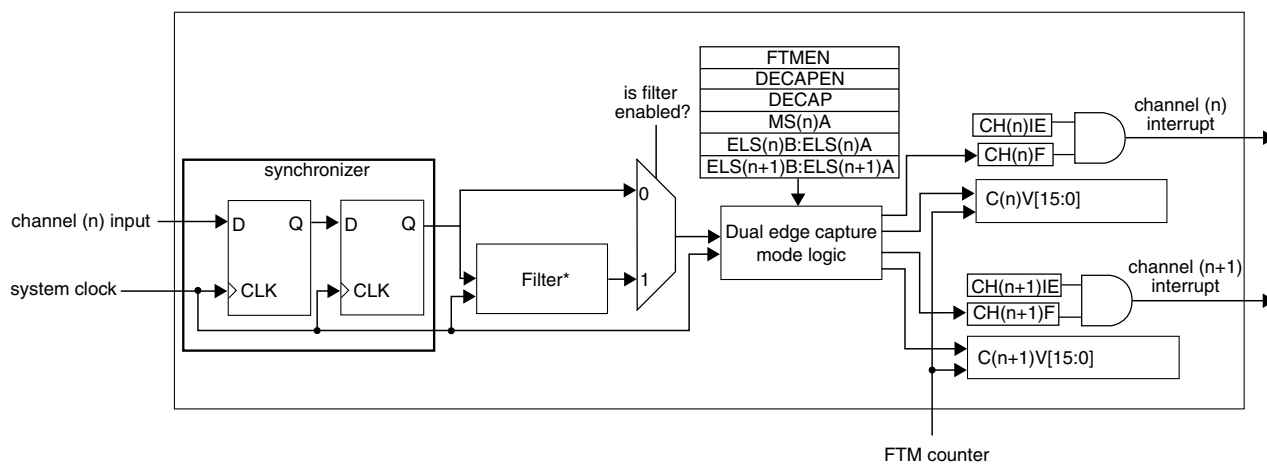

* Filtering function for dual edge capture mode is only available in the channels 0 and 2

Figure 36-244. Dual Edge Capture Mode Block Diagram

The MS(n)A bit defines if the dual edge capture mode is one-shot or continuous.

The ELS(n)B:ELS(n)A bits select the edge that is captured by channel (n), and ELS(n+1)B:ELS(n+1)A bits select the edge that is captured by channel (n+1). If both ELS(n)B:ELS(n)A and ELS(n+1)B:ELS(n+1)A bits select the same edge, then it is the period measurement. If these bits select different edges, then it is a pulse width measurement.

In the dual edge capture mode, only channel (n) input is used and channel (n+1) input is ignored.

If the selected edge by channel (n) bits is detected at channel (n) input, then CH(n)F bit is set and the channel (n) interrupt is generated (if CH(n)IE = 1). If the selected edge by channel (n+1) bits is detected at channel (n) input and (CH(n)F = 1), then CH(n+1)F bit is set and the channel (n+1) interrupt is generated (if CH(n+1)IE = 1).

The $C(n)V$ register stores the value of FTM counter when the selected edge by channel (n) is detected at channel (n) input. The $C(n+1)V$ register stores the value of FTM counter when the selected edge by channel (n+1) is detected at channel (n) input.

In this mode, the pair channels coherency mechanism ensures coherent data when the $C(n)V$ and $C(n+1)V$ registers are read. The only requirement is that $C(n)V$ must be read before $C(n+1)V$.

Note

- The $CH(n)F$, $CH(n)IE$, $MS(n)A$, $ELS(n)B$, and $ELS(n)A$ bits are channel (n) bits.
- The $CH(n+1)F$, $CH(n+1)IE$, $MS(n+1)A$, $ELS(n+1)B$, and $ELS(n+1)A$ bits are channel (n+1) bits.
- It is expected that the dual edge capture mode be used with $ELS(n)B:ELS(n)A = 0:1$ or $1:0$, $ELS(n+1)B:ELS(n+1)A = 0:1$ or $1:0$ and the FTM counter in free running counter mode ([Free Running Counter](#)).

36.4.24.1 One-Shot Capture Mode

The one-shot capture mode is selected when ($FTMEN = 1$), ($DECAPEN = 1$), and ($MS(n)A = 0$). In this capture mode, only one pair of edges at the channel (n) input is captured. The $ELS(n)B:ELS(n)A$ bits select the first edge to be captured, and $ELS(n+1)B:ELS(n+1)A$ bits select the second edge to be captured.

The edge captures are enabled while $DECAP$ bit is set. For each new measurement in one-shot capture mode, first the $CH(n)F$ and $CH(n+1)$ bits must be cleared, and then the $DECAP$ bit must be set.

In this mode, the $DECAP$ bit is automatically cleared by FTM when the edge selected by channel (n+1) is captured. Therefore, while $DECAP$ bit is set, the one-shot capture is in process. When this bit is cleared, both edges were captured and the captured values are ready for reading in the $C(n)V$ and $C(n+1)V$ registers.

Similarly, when the $CH(n+1)F$ bit is set, both edges were captured and the captured values are ready for reading in the $C(n)V$ and $C(n+1)V$ registers.

36.4.24.2 Continuous Capture Mode

The continuous capture mode is selected when (FTMEN = 1), (DECAPEN = 1), and (MS(n)A = 1). In this capture mode, the edges at the channel (n) input are captured continuously. The ELS(n)B:ELS(n)A bits select the initial edge to be captured, and ELS(n+1)B:ELS(n+1)A bits select the final edge to be captured.

The edge captures are enabled while DECAP bit is set. For the initial use, first the CH(n)F and CH(n+1)F bits must be cleared, and then DECAP bit must be set to start the continuous measurements.

When the CH(n+1)F bit is set, both edges were captured and the captured values are ready for reading in the C(n)V and C(n+1)V registers. The latest captured values are always available in these registers even after the DECAP bit is cleared.

In this mode, it is possible to clear only the CH(n+1)F bit. Therefore, when the CH(n+1)F bit is set again, the latest captured values are available in C(n)V and C(n+1)V registers.

For a new sequence of the measurements in the dual edge capture – continuous mode, it is recommended to clear the CH(n)F and CH(n+1)F bits to start new measurements.

36.4.24.3 Pulse Width Measurement

If the channel (n) is configured to capture rising edges (ELS(n)B:ELS(n)A = 0:1) and the channel (n+1) to capture falling edges (ELS(n+1)B:ELS(n+1)A = 1:0), then the positive polarity pulse width is measured. If the channel (n) is configured to capture falling edges (ELS(n)B:ELS(n)A = 1:0) and the channel (n+1) to capture rising edges (ELS(n+1)B:ELS(n+1)A = 0:1), then the negative polarity pulse width is measured.

The pulse width measurement can be made in one-shot capture mode ([One-Shot Capture Mode](#)) or continuous capture mode ([Continuous Capture Mode](#)).

The following figure shows an example of the dual edge capture – one-shot mode used to measure the positive polarity pulse width. The DECAPEN bit selects the dual edge capture mode, so it keeps set in all operation mode. The DECAP bit is set to enable the measurement of next positive polarity pulse width. The CH(n)F bit is set when the first edge of this pulse is detected, that is, the edge selected by ELS(n)B:ELS(n)A bits. The CH(n+1)F bit is set and DECAP bit is cleared when the second edge of this pulse is detected, that is, the edge selected by ELS(n+1)B:ELS(n+1)A bits. Both DECAP and CH(n+1)F bits indicate when two edges of the pulse were captured and the C(n)V and C(n+1)V registers are ready for reading.

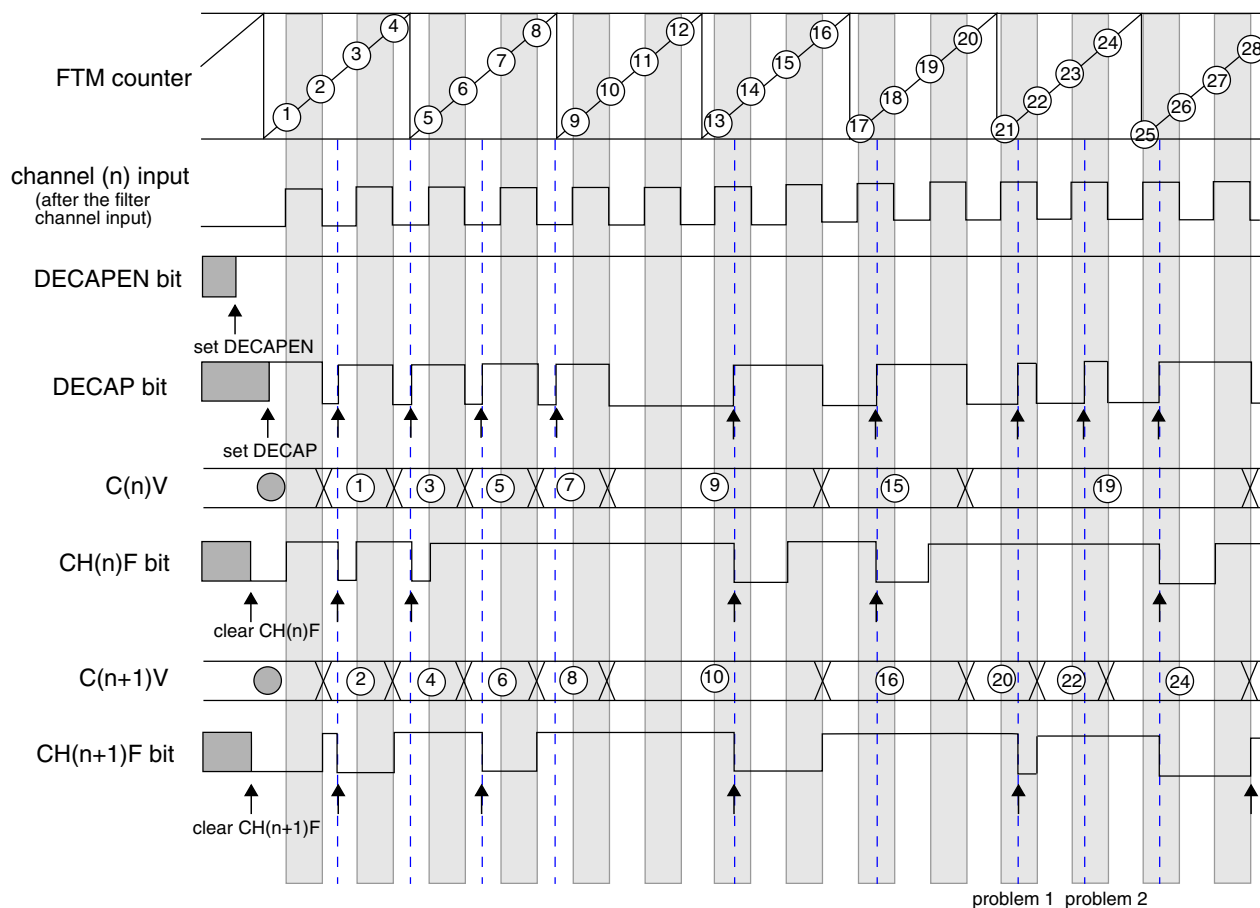
Note

- The commands set DECAPEN, set DECAP, clear CH(n)F, and clear CH(n+1)F are made by the user.
- Problem 1: channel (n) input = 1, set DECAP, not clear CH(n)F, and clear CH(n+1)F.
- Problem 2: channel (n) input = 1, set DECAP, not clear CH(n)F, and not clear CH(n+1)F.

Figure 36-245. Dual Edge Capture – One-Shot Mode for Positive Polarity Pulse Width Measurement

The following figure shows an example of the dual edge capture – continuous mode used to measure the positive polarity pulse width. The DECAPEN bit selects the dual edge capture mode, so it keeps set in all operation mode. While the DECAP bit is set the configured measurements are made. The CH(n)F bit is set when the first edge of the positive polarity pulse is detected, that is, the edge selected by ELS(n)B:ELS(n)A bits. The CH(n+1)F bit is set when the second edge of this pulse is detected, that is, the edge selected by ELS(n+1)B:ELS(n+1)A bits. The CH(n+1)F bit indicates when two edges of the pulse were captured and the C(n)V and C(n+1)V registers are ready for reading.

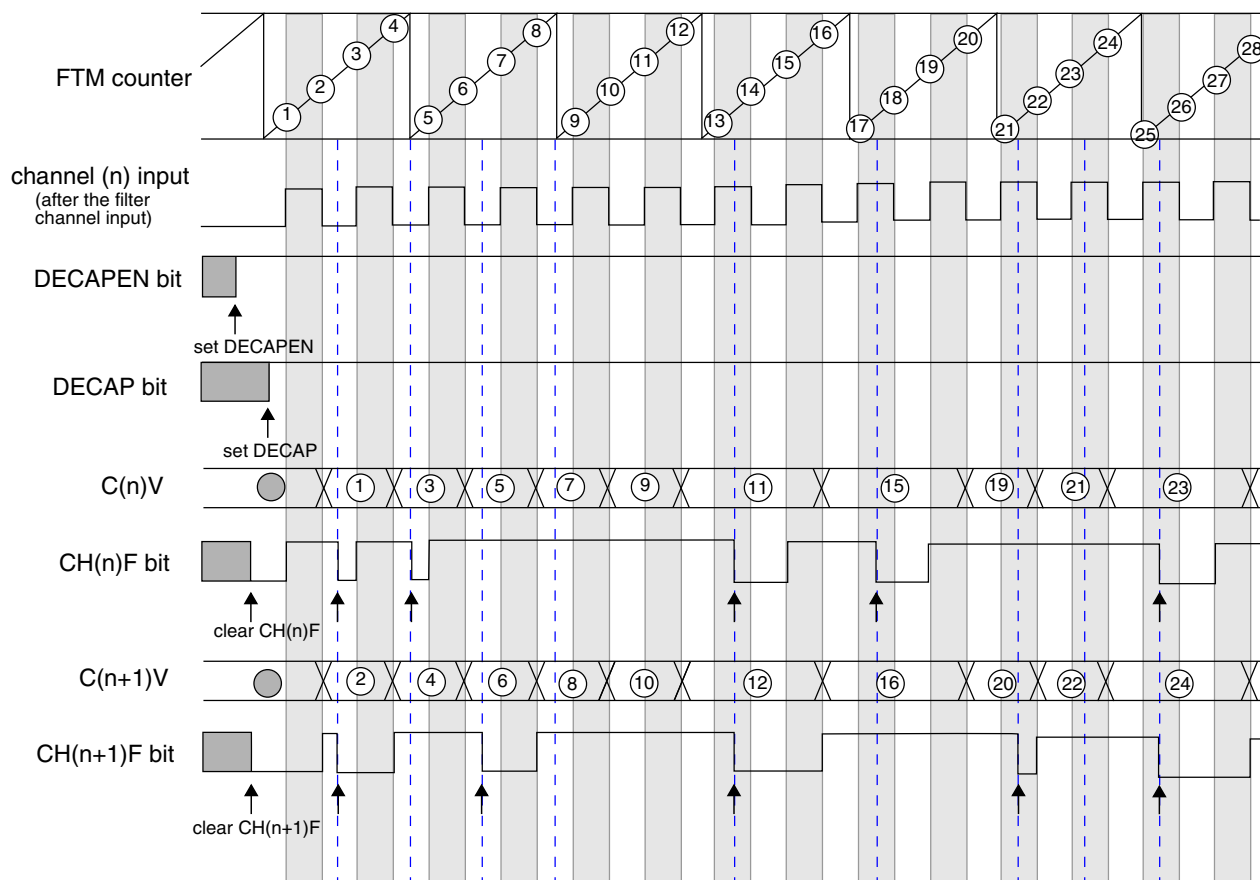

Note

- The commands set DECAPEN, set DECAP, clear CH(n)F, and clear CH(n+1)F are made by the user.

Figure 36-246. Dual Edge Capture – Continuous Mode for Positive Polarity Pulse Width Measurement

36.4.24.4 Period Measurement

If the channels (n) and (n+1) are configured to capture consecutive edges of the same polarity, then the period of the channel (n) input signal is measured. If both channels (n) and (n+1) are configured to capture rising edges ($ELS(n)B:ELS(n)A = 0:1$ and $ELS(n+1)B:ELS(n+1)A = 0:1$), then the period between two consecutive rising edges is measured. If both channels (n) and (n+1) are configured to capture falling edges ($ELS(n)B:ELS(n)A = 1:0$ and $ELS(n+1)B:ELS(n+1)A = 1:0$), then the period between two consecutive falling edges is measured.

The period measurement can be made in one-shot capture mode ([One-Shot Capture Mode](#)) or continuous capture mode ([Continuous Capture Mode](#)).

The following figure shows an example of the dual edge capture – one-shot mode used to measure the period between two consecutive rising edges. The DECAPEN bit selects the dual edge capture mode, so it keeps set in all operation mode. The DECAP bit is set to enable the measurement of next period. The CH(n)F bit is set when the first rising edge is detected, that is, the edge selected by ELS(n)B:ELS(n)A bits. The CH(n+1)F bit is set and DECAP bit is cleared when the second rising edge is detected, that is, the edge selected by ELS(n+1)B:ELS(n+1)A bits. Both DECAP and CH(n+1)F bits indicate when two selected edges were captured and the C(n)V and C(n+1)V registers are ready for reading.

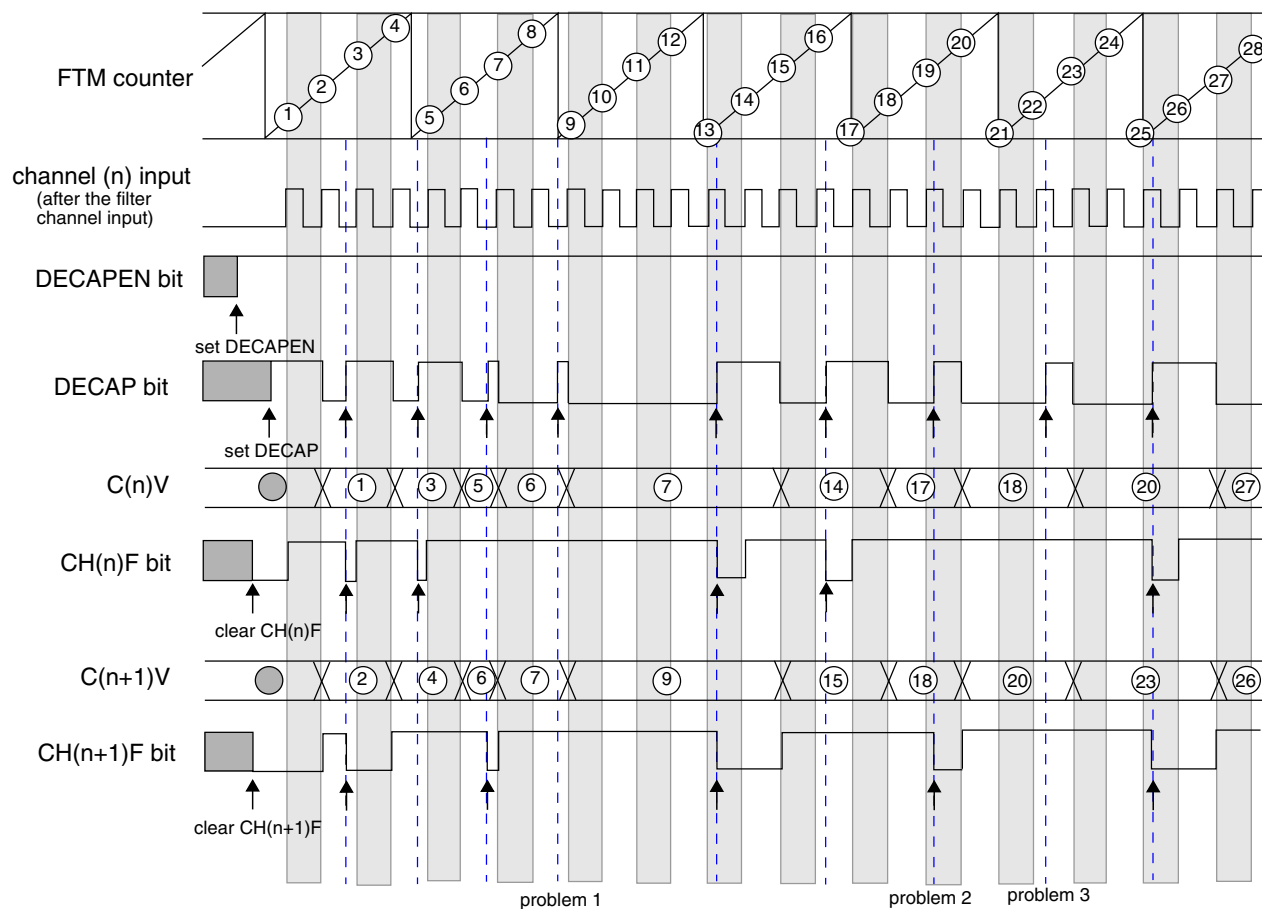

Note

- The commands set DECAPEN, set DECAP, clear CH(n)F, and clear CH(n+1)F are made by the user.
- Problem 1: channel (n) input = 0, set DECAP, not clear CH(n)F, and not clear CH(n+1)F.
- Problem 2: channel (n) input = 1, set DECAP, not clear CH(n)F, and clear CH(n+1)F.
- Problem 3: channel (n) input = 1, set DECAP, not clear CH(n)F, and not clear CH(n+1)F.

Figure 36-247. Dual Edge Capture – One-Shot Mode to Measure of the Period Between Two Consecutive Rising Edges

The following figure shows an example of the dual edge capture – continuous mode used to measure the period between two consecutive rising edges. The DECAPEN bit selects the dual edge capture mode, so it keeps set in all operation mode. While the DECAP bit is set the configured measurements are made. The CH(n)F bit is set when the first rising

edge is detected, that is, the edge selected by ELS(n)B:ELS(n)A bits. The CH(n+1)F bit is set when the second rising edge is detected, that is, the edge selected by ELS(n+1)B:ELS(n+1)A bits. The CH(n+1)F bit indicates when two edges of the period were captured and the C(n)V and C(n+1)V registers are ready for reading.

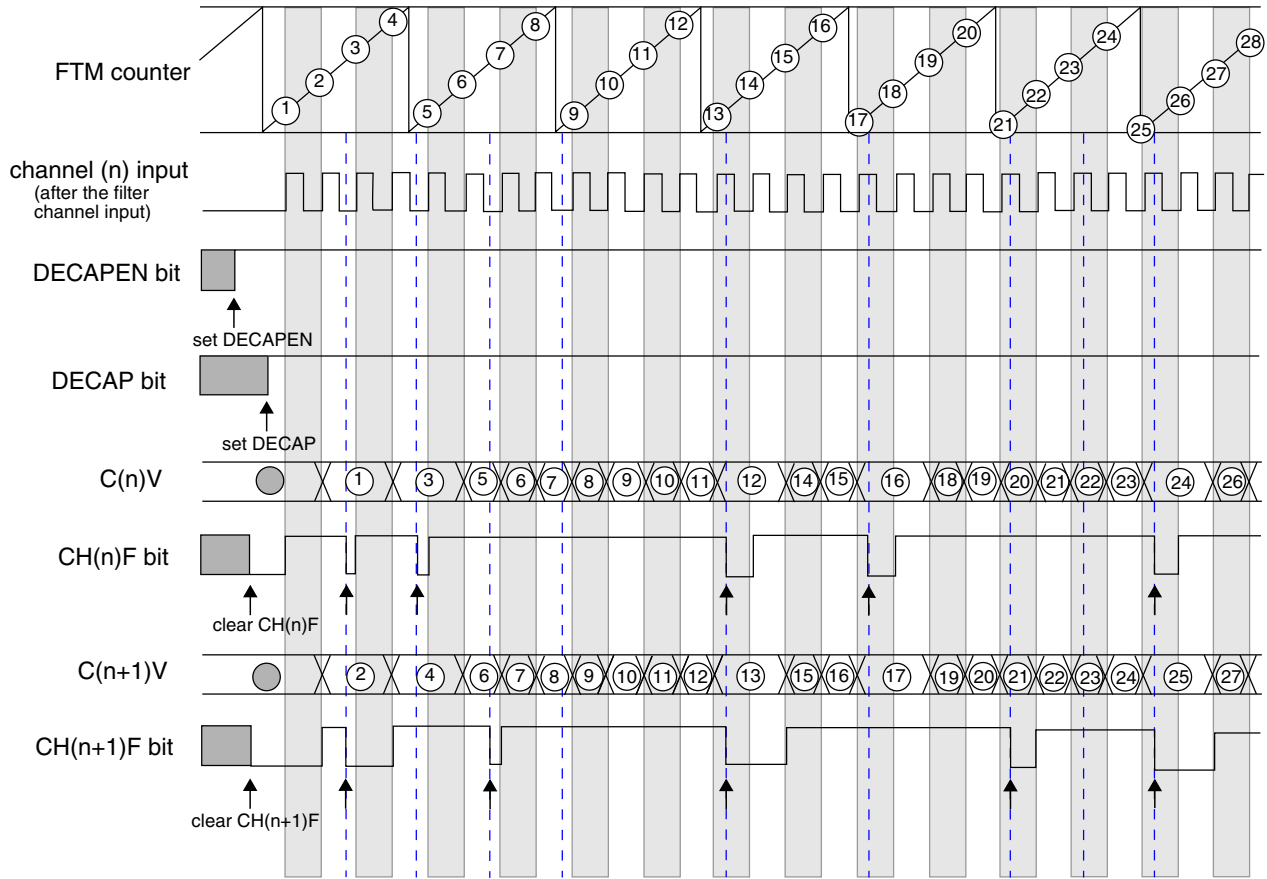

Note
 - The commands set DECAPEN, set DECAP, clear CH(n)F, and clear CH(n+1)F are made by the user.

Figure 36-248. Dual Edge Capture – Continuous Mode to Measure of the Period Between Two Consecutive Rising Edges

36.4.24.5 Read Coherency Mechanism

The dual edge capture mode implements a read coherency mechanism between the FTM counter value captured in C(n)V and C(n+1)V registers. The read coherency mechanism is illustrated in the following figure. In this example, the channels (n) and (n+1) are in dual edge capture – continuous mode for positive polarity pulse width measurement. Thus, the channel (n) is configured to capture the FTM counter value when there is a rising edge at channel (n) input signal, and channel (n+1) to capture the FTM counter value when there is a falling edge at channel (n) input signal.

When a rising edge occurs in the channel (n) input signal, the FTM counter value is captured into channel (n) capture buffer. The channel (n) capture buffer value is transferred to C(n)V register when a falling edge occurs in the channel (n) input signal. C(n)V register has the FTM counter value when the previous rising edge occurred, and the channel (n) capture buffer has the FTM counter value when the last rising edge occurred.

When a falling edge occurs in the channel (n) input signal, the FTM counter value is captured into channel (n+1) capture buffer. The channel (n+1) capture buffer value is transferred to C(n+1)V register when the C(n)V register is read.

In the following figure, the read of C(n)V returns the FTM counter value when the event 1 occurred and the read of C(n+1)V returns the FTM counter value when the event 2 occurred.

C(n)V register must be read prior to C(n+1)V register in dual edge capture one-shot and continuous modes for the read coherency mechanism works properly.

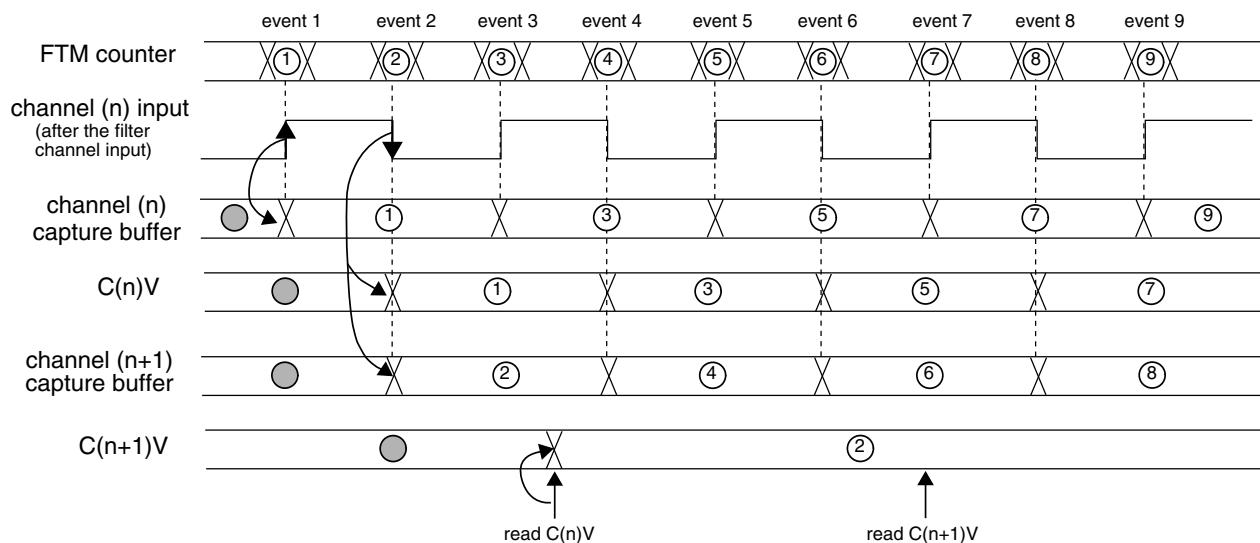

Figure 36-249. Dual Edge Capture Mode Read Coherency Mechanism

36.4.25 Quadrature Decoder Mode

The quadrature decoder mode is selected if (FTMEN = 1) and (QUADEN = 1). The quadrature decoder mode uses the input signals phase A and B to control the FTM counter increment and decrement. The following figure shows the quadrature decoder block diagram.

Each one of input signals phase A and B has a filter that is equivalent to the filter used in the channels input ([Filter for Input Capture Mode](#)). The phase A input filter is enabled by PHAFLTREN bit and this filter's value is defined by CH0FVAL[3:0] bits

Functional Description

(CH(n)FVAL[3:0] bits in FILTER0 register). The phase B input filter is enabled by PHBFLTREN bit and this filter's value is defined by CH1FVAL[3:0] bits (CH(n+1)FVAL[3:0] bits in FILTER0 register).

Except for CH0FVAL[3:0] and CH1FVAL[3:0] bits, no channel logic is used in quadrature decoder mode.

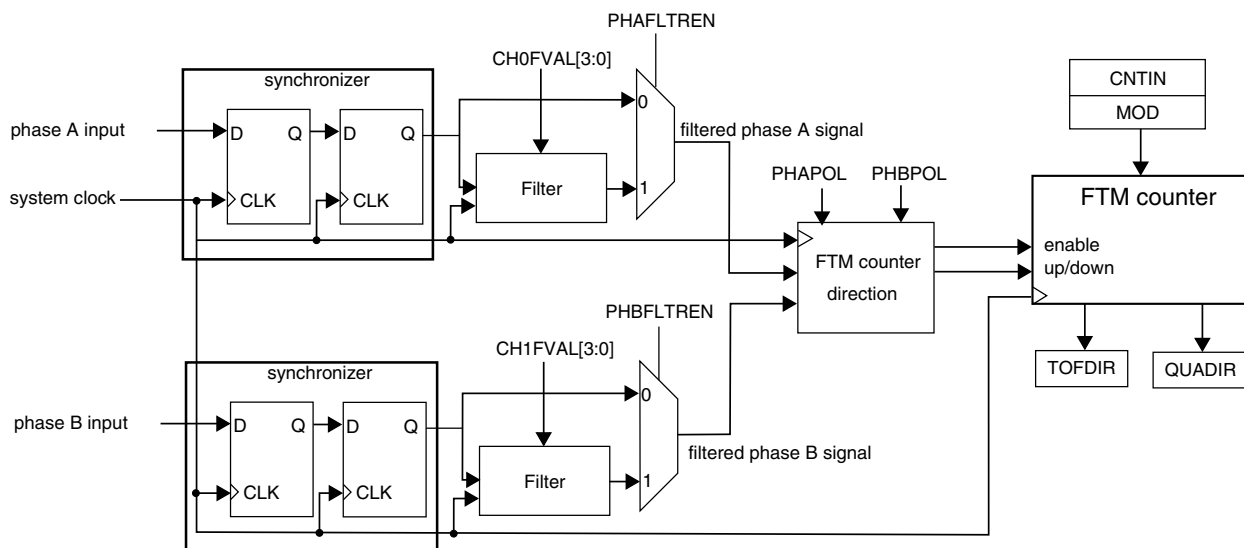

Figure 36-250. Quadrature Decoder Block Diagram

Note

It is important to notice that the FTM counter is clocked by the phase A and B input signals when quadrature decoder mode is selected. Therefore it is expected that the quadrature decoder be used only with the FTM channels in input capture or output compare modes.

The PHAPOL bit selects the polarity of the phase A input, and the PHBPOL bit selects the polarity of the phase B input.

The QUADM0DE selects the encoding mode used in the quadrature decoder mode. If QUADM0DE = 1, then the count and direction encoding mode (see the following figure) is enabled. In this mode, the phase B input value indicates the counting direction (FTM counter increment or decrement), and the phase A input defines the counting rate (FTM counter is updated when there is a rising edge at phase A input signal).

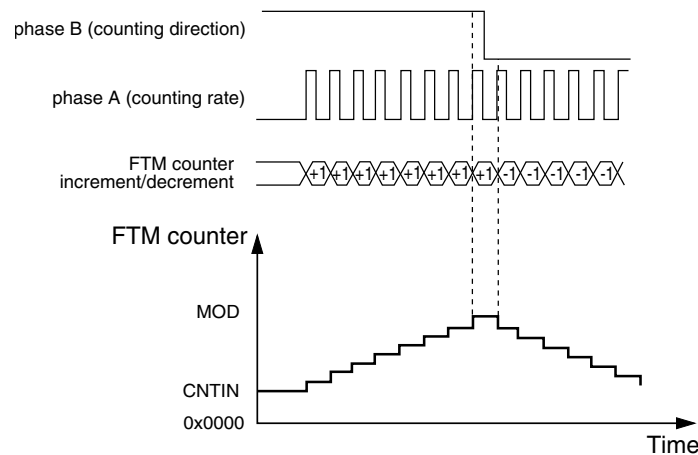

Figure 36-251. Quadrature Decoder – Count and Direction Encoding Mode

If $QUADM\text{MODE} = 0$, then the phase A and phase B encoding mode (see the following figure) is enabled. In this mode, the relationship between phase A and B signals indicates the counting direction, and phase A and B signals define the counting rate (FTM counter is updated when there is an edge either at the phase A or phase B signals).

If $PHAPOL = 0$ and $PHBPOL = 0$, then the FTM counter increment happens when:

- there is a rising edge at phase A signal and phase B signal is at logic zero;
- there is a rising edge at phase B signal and phase A signal is at logic one;
- there is a falling edge at phase B signal and phase A signal is at logic zero;
- there is a falling edge at phase A signal and phase B signal is at logic one;

and the FTM counter decrement happens when:

- there is a falling edge at phase A signal and phase B signal is at logic zero;
- there is a falling edge at phase B signal and phase A signal is at logic one;
- there is a rising edge at phase B signal and phase A signal is at logic zero;
- there is a rising edge at phase A signal and phase B signal is at logic one.

functional Description

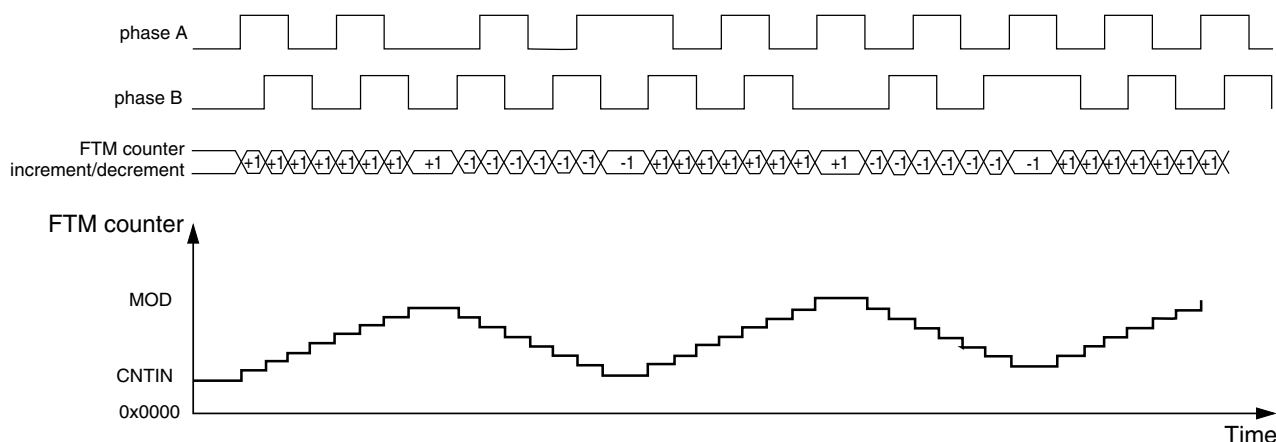

Figure 36-252. Quadrature Decoder – Phase A and Phase B Encoding Mode

The following figure shows the FTM counter overflow in up counting. In this case, when the FTM counter changes from MOD to CNTIN, TOF and TOFDIR bits are set. TOF bit indicates the FTM counter overflow occurred. TOFDIR indicates the counting was up when the FTM counter overflow occurred.

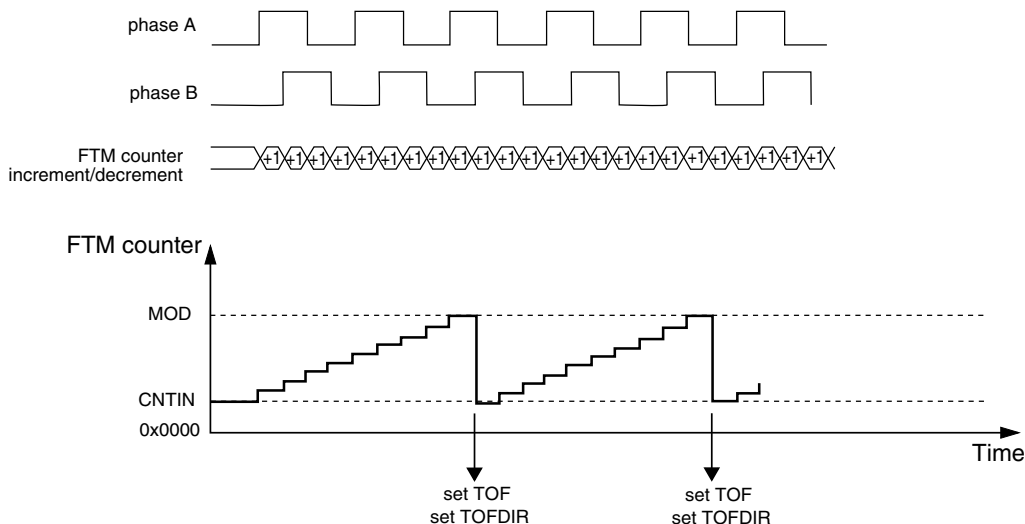

Figure 36-253. FTM Counter Overflow in Up Counting for Quadrature Decoder Mode

The following figure shows the FTM counter overflow in down counting. In this case, when the FTM counter changes from CNTIN to MOD, TOF bit is set and TOFDIR bit is cleared. TOF bit indicates the FTM counter overflow occurred. TOFDIR indicates the counting was down when the FTM counter overflow occurred.

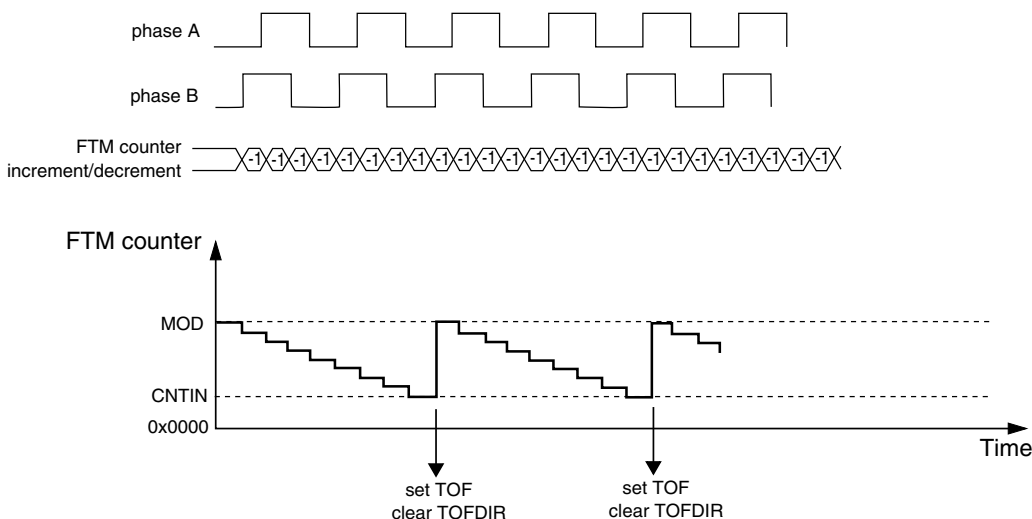

Figure 36-254. FTM Counter Overflow in Down Counting for Quadrature Decoder Mode

36.4.25.1 Quadrature Decoder Boundary Conditions

The following figures are examples of motor jittering which causes the FTM counter transitions as indicated by these figures. It is expected to observe these behaviors in motor position control applications.

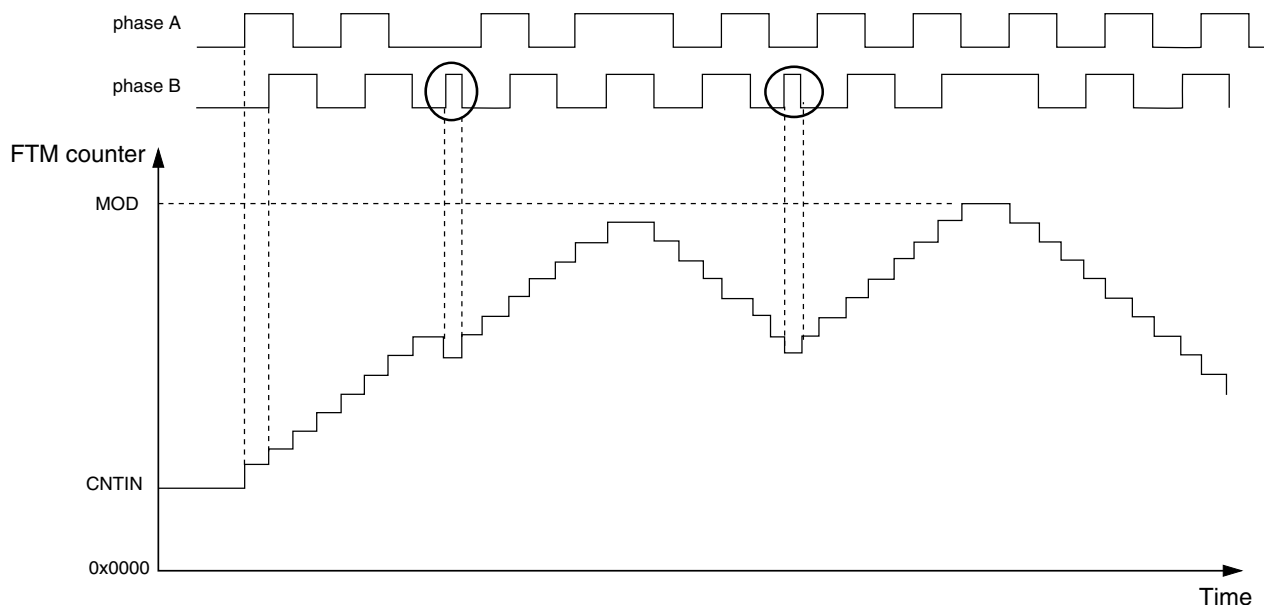

Figure 36-255. Motor Position Jittering in a Mid Count Value

The following figure shows motor jittering produced by the phase B and A pulses respectively. The first highlighted transition causes a jitter on the FTM counter value near the maximum count value (MOD). The second indicated transition occurs on phase A and causes the FTM counter transition between the maximum and minimum count values which are defined by MOD and CNTIN registers.

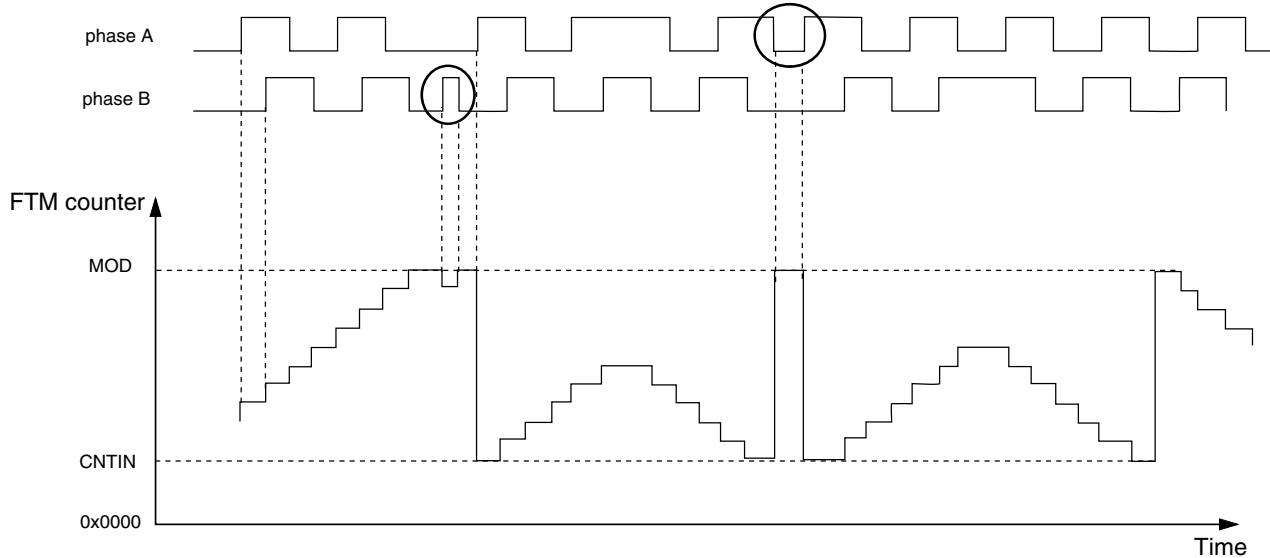

Figure 36-256. Motor Position Jittering Near Maximum and Minimum Count Value

The appropriate settings of the phase A and phase B input filters are important to avoid glitches that may cause oscillation on the FTM counter value. The preceding figures show examples of oscillations that can be caused by poor input filter setup. Thus, it is important to guarantee a minimum pulse width to avoid these oscillations.

36.4.26 BDM Mode

When the chip is in BDM mode, the BDMODE[1:0] bits select the behavior of the FTM counter, the CH(n)F bit, the channels output, and the writes to the MOD, CNTIN, and C(n)V registers according to the following table.

Table 36-249. FTM Behavior When the Chip Is in BDM Mode

BDMODE	FTM Counter	CH(n)F Bit	FTM Channels Output	Writes to MOD, CNTIN, and C(n)V Registers
00	Stopped	can be set	Functional mode	Writes to these registers bypass the registers buffers
01	Stopped	is not set	The channels outputs are forced to their safe value according to POLn bit	Writes to these registers bypass the registers buffers

Table continues on the next page...

Table 36-249. FTM Behavior When the Chip Is in BDM Mode (continued)

BDMMODE	FTM Counter	CH(n)F Bit	FTM Channels Output	Writes to MOD, CNTIN, and C(n)V Registers
10	Stopped	is not set	The channels outputs are frozen when the chip enters in BDM mode	Writes to these registers bypass the registers buffers
11	Functional mode	can be set	Functional mode	Functional mode

Note that if $BDMMODE[1:0] = 2'b00$ then the channels outputs remain at the value when the chip enters in BDM mode, since the FTM counter is stopped. However, the following situations modify the channels outputs in this BDM mode.

- Write any value to CNT register ([Counter Reset](#)). In this case, the FTM counter is updated with the CNTIN register value and the channels outputs are updated to the initial value – except for those channels set to output compare mode.
- FTM counter is reset by PWM synchronization mode ([FTM Counter Synchronization](#)). In this case, the FTM counter is updated with the CNTIN register value and the channels outputs are updated to the initial value – except for channels in output compare mode.
- In the channels outputs initialization ([Initialization](#)), the channel (n) output is forced to the CH(n)OI bit value when the value 1 is written to INIT bit.

Note

It is expected that the $BDMMODE[1:0] = 2'b00$ is not used with the fault control ([Fault Control](#)). Even if the fault control is enabled and a fault condition exists, the channels outputs values are as defined above.

36.4.27 Intermediate Load

The PWMLOAD register allows software to update the MOD, CNTIN, and C(n)V registers with the content of the register buffer at a defined load point. In this case it is not required to use the PWM synchronization control.

A possible loading point is when the FTM counter wraps from MOD value to CNTIN value. This loading point is always enabled. Another possible loading point is at the channel (j) match (FTM counter = C(j)V). This loading point is enabled when $CHjSEL = 1$. The following figure shows some examples of enabled loading points.

After enabling the loading points, the LDOK bit needs to be set for the load to occur. In this case the load occurs at the next enabled loading point according to the following conditions:

- If a new value was written to the MOD register, then the MOD register is updated with its write buffer value.
- If a new value was written to the CNTIN register and CNTINC = 1, then the CNTIN register is updated with its write buffer value.
- If a new value was written to the C(n)V register and SYNCEN_m = 1 – where m indicates the pair channels (n) and (n+1), then the C(n)V register is updated with its write buffer value.
- If a new value was written to the C(n+1)V register and SYNCEN_m = 1 – where m indicates the pair channels (n) and (n+1), then the C(n+1)V register is updated with its write buffer value.

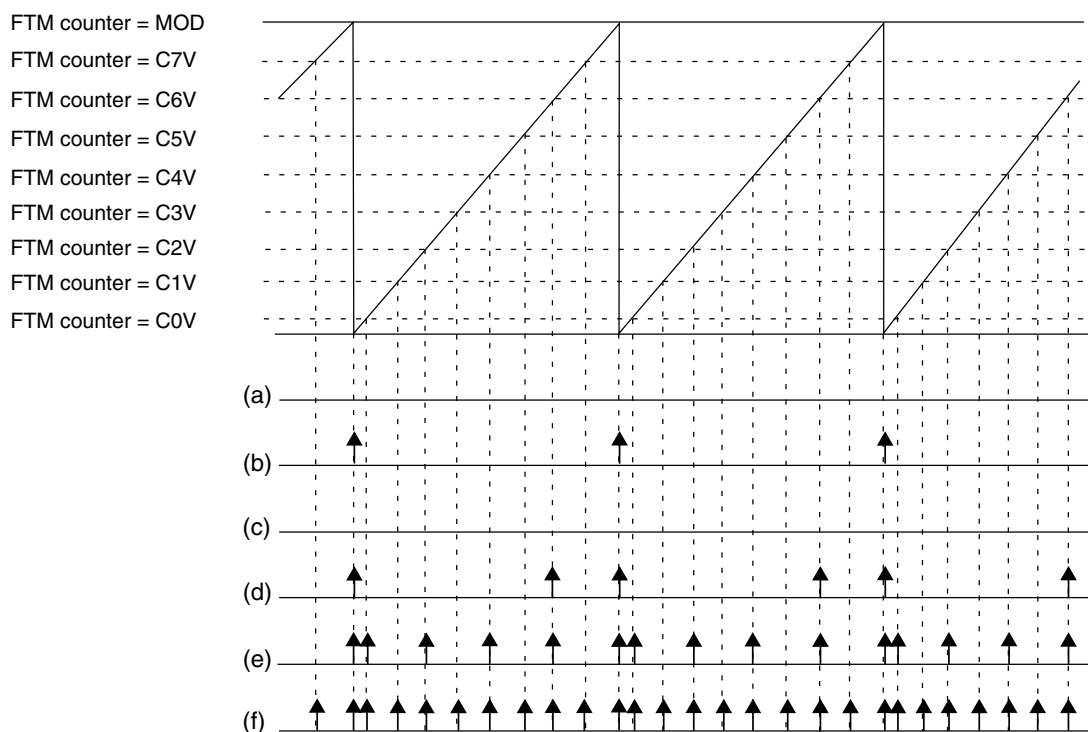

NOTE

- (a) LDOK = 0, CH0SEL = 0, CH1SEL = 0, CH2SEL = 0, CH3SEL = 0, CH4SEL = 0, CH5SEL = 0, CH6SEL = 0, CH7SEL = 0
- (b) LDOK = 1, CH0SEL = 0, CH1SEL = 0, CH2SEL = 0, CH3SEL = 0, CH4SEL = 0, CH5SEL = 0, CH6SEL = 0, CH7SEL = 0
- (c) LDOK = 0, CH0SEL = 0, CH1SEL = 0, CH2SEL = 0, CH3SEL = 1, CH4SEL = 0, CH5SEL = 0, CH6SEL = 0, CH7SEL = 0
- (d) LDOK = 1, CH0SEL = 0, CH1SEL = 0, CH2SEL = 0, CH3SEL = 0, CH4SEL = 0, CH5SEL = 0, CH6SEL = 1, CH7SEL = 0
- (e) LDOK = 1, CH0SEL = 1, CH1SEL = 0, CH2SEL = 1, CH3SEL = 0, CH4SEL = 1, CH5SEL = 0, CH6SEL = 1, CH7SEL = 0
- (f) LDOK = 1, CH0SEL = 1, CH1SEL = 1, CH2SEL = 1, CH3SEL = 1, CH4SEL = 1, CH5SEL = 1, CH6SEL = 1, CH7SEL = 1

Figure 36-257. Loading Points for Intermediate Load

NOTE

- If ELSjB and ELSjA bits are different from zero, then the channel (j) output signal is generated according to the configured output mode. If ELSjB and ELSjA bits are zero, then the generated signal is not available on channel (j) output.
- If CHjIE = 1, then the channel (j) interrupt is generated when the channel (j) match occurs.
- At the intermediate load neither the channels outputs nor the FTM counter are changed. Software must set the intermediate load at a safe point in time.
- It is expected that the intermediate load feature be used only in combine mode.

36.4.28 Global Time Base (GTB)

The global time base (GTB) is a FTM function that allows the synchronization of multiple FTM modules on a chip. The following figure shows an example of the GTB feature used to synchronize two FTM modules. In this case, the FTM A and B channels can behave as if just one FTM module was used, that is, a global time base.

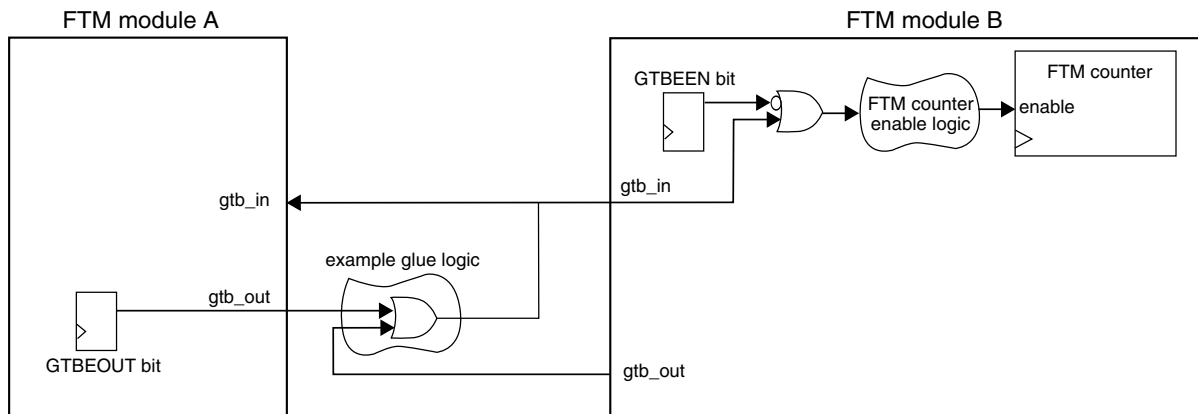

Figure 36-258. Global Time Base (GTB) Block Diagram

The GTB functionality is implemented by the GTBEEN and GTBEOUT bits in the CONF register, the internal input signal *gtb_in* and the internal output signal *gtb_out*. The GTBEEN bit enables *gtb_in* to control the FTM counter enable signal:

- If GTBEEN = 0, each one of FTM modules works independently according to their configured mode.
- If GTBEEN = 1, the FTM counter update is enabled only when *gtb_in* is 1.

In the configuration described in the preceding figure, FTM modules A and B have their FTM counters enabled if at least one of the `gtb_out` signals from one of the FTM modules is 1. There are several possible configurations for the interconnection of the `gtb_in` and `gtb_out` signals (represented by the example glue logic shown in the figure). Note that these configurations are chip-dependent and implemented outside of the FTM modules. See the Chip Configuration details for the chip's specific implementation.

NOTE

- In order to use the internal GTB signals to synchronize the FTM counter of different FTM modules, the configuration of each FTM module should guarantee that its FTM counter starts counting as soon as the `gtb_in` signal is 1.
- The GTB feature does not provide continuous synchronization of FTM counters, meaning that the FTM counters may lose synchronization during FTM operation. The GTB feature only allows the FTM counters to *start* their operation synchronously.

36.4.28.1 Enabling the global time base (GTB)

To enable the GTB feature, follow these steps for each participating FTM module:

1. Stop the FTM counter: Write 00b to `SC[CLKS]`.
2. Program the FTM module to the intended configuration. (The operation mode needs to be consistent across all participating modules.)
3. Write 1 to `CONF[GTBEEN]` and write 0 to `CONF[GTBEOUT]` at the same time.
4. Select the intended FTM counter clock source in `SC[CLKS]`. (The clock source needs to be consistent across all participating modules.)
5. Reset the FTM counter: Write any value to the `CNT` register.

To initiate the GTB feature, follow these steps for the FTM module used as the time base:

1. Write 1 to `CONF[GTBEOUT]`.
2. If needed, configure the GTB glue logic connecting the FTM modules within the chip. Some chips do not require configuration of glue logic. See the Chip Configuration details for the chip's specific implementation.

36.5 Reset Overview

The FTM is reset whenever any chip reset occurs.

When the FTM exits from reset:

- the FTM counter and the prescaler counter are zero and are stopped (CLKS[1:0] = 00b);
- the timer overflow interrupt is zero (Timer Overflow Interrupt);
- the channels interrupts are zero (Channel (n) Interrupt);
- the fault interrupt is zero (Fault Interrupt);
- the channels are in input capture mode (Input Capture Mode);
- the channels outputs are zero;
- the channels pins are not controlled by FTM (ELS(n)B:ELS(n)A = 0:0) ().

The following figure shows the FTM behavior after the reset. At the reset (item 1), the FTM counter is disabled (see the description of the CLKS field in the Status and Control register), its value is updated to zero and the pins are not controlled by FTM ().

After the reset, the FTM should be configured (item 2). It is necessary to define the FTM counter mode, the FTM counting limits (MOD and CNTIN registers value), the channels mode and CnV registers value according to the channels mode.

Thus, it is recommended to write any value to CNT register (item 3). This write updates the FTM counter with the CNTIN register value and the channels output with its initial value (except for channels in output compare mode) (Counter Reset).

The next step is to select the FTM counter clock by the CLKS[1:0] bits (item 4). It is important to highlight that the pins are only controlled by FTM when CLKS[1:0] bits are different from zero ().

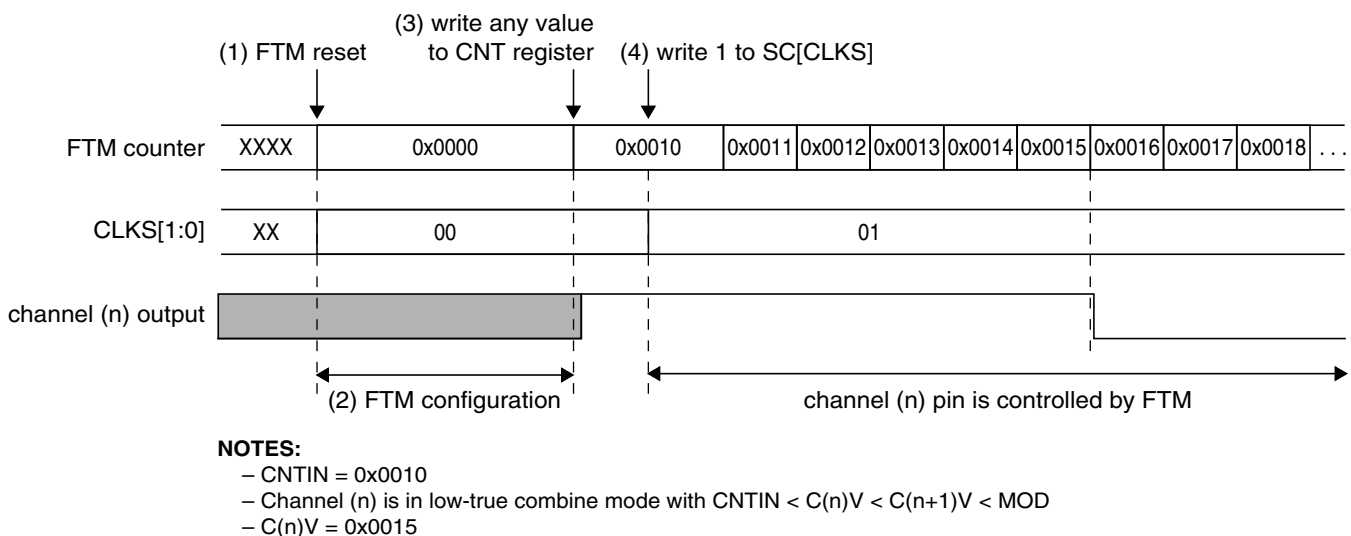
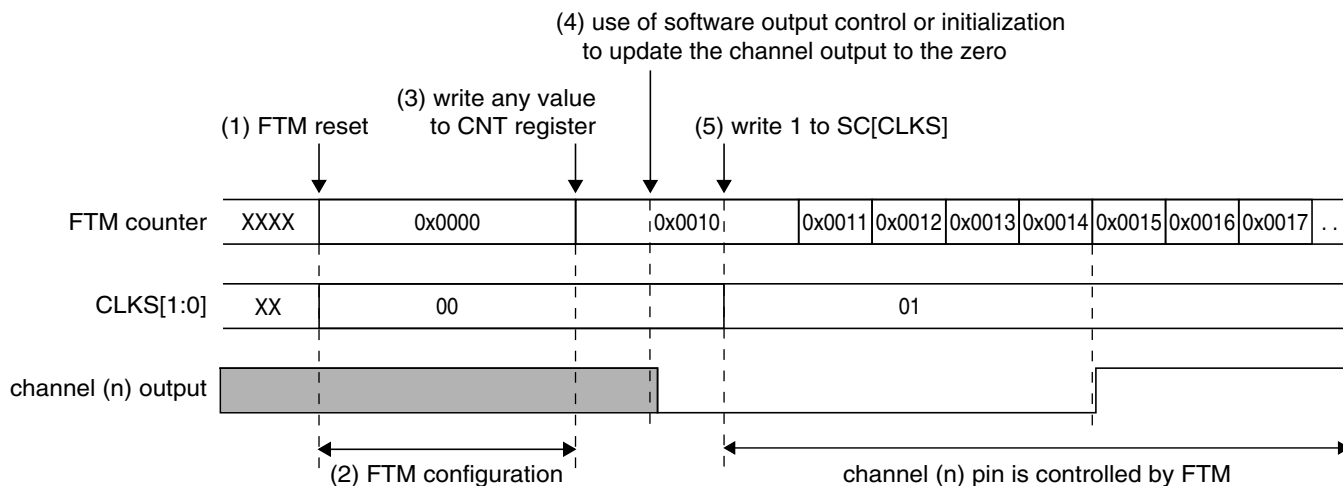

Figure 36-259. FTM Behavior After Reset When the Channel (n) Is in Combine Mode

The following figure shows an example when the channel (n) is in output compare mode and the channel (n) output is toggled when there is a match. In the output compare mode, the channel output is not updated to its initial value when there is a write to CNT register (item 3). In this case, it is recommended to use the software output control ([Software Output Control](#)) or the initialization ([Initialization](#)) to update the channel output to the selected value (item 4).



NOTES:

- CNTIN = 0x0010
- Channel (n) is in output compare and the channel (n) output is toggled when there is a match
- C(n)V = 0x0014

Figure 36-260. FTM Behavior After Reset When the Channel (n) Is in Output Compare Mode

36.6 FTM Interrupts

This section describes FTM interrupts.

36.6.1 Timer Overflow Interrupt

The timer overflow interrupt is generated when (TOIE = 1) and (TOF = 1).

36.6.2 Channel (n) Interrupt

The channel (n) interrupt is generated when (CHnIE = 1) and (CHnF = 1).

36.6.3 Fault Interrupt

The fault interrupt is generated when (FAULTIE = 1) and (FAULTF = 1).



Chapter 37

Periodic Interrupt Timer (PIT)

37.1 Introduction

NOTE

For the chip-specific implementation details of this module's instances see the chip configuration chapter.

The PIT timer module is an array of timers that can be used to raise interrupts and trigger DMA channels.

37.1.1 Block Diagram

The following figure shows the PIT block diagram.

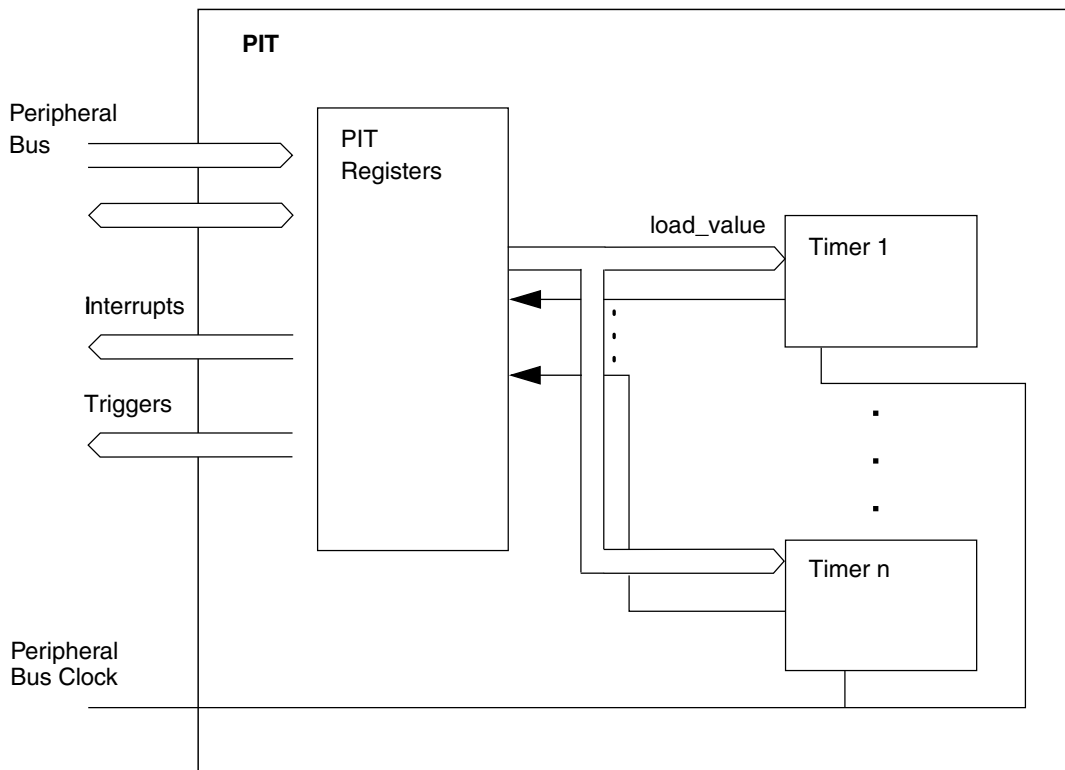

Figure 37-1. Block diagram of the PIT

NOTE

Refer to the Chip Configuration information for the number of PIT channels used in this MCU.

37.1.2 Features

The main features of this block are:

- Timers can generate DMA trigger pulses
- Timers can generate interrupts
- All interrupts are maskable
- Independent timeout periods for each timer

37.2 Signal Description

The PIT module has no external pins.

37.3 Memory Map/Register Description

This section provides a detailed description of all registers accessible in the PIT module.

NOTE

Reserved registers will read as 0, writes will have no effect.

NOTE

Refer to the Chip Configuration information for the number of PIT channels used in this MCU.

PIT memory map

Absolute address (hex)	Register name	Width (in bits)	Access	Reset value	Section/page
4003_7000	PIT Module Control Register (PIT_MCR)	32	R/W	0000_0002h	37.3.1/934
4003_7100	Timer Load Value Register (PIT_LDVAL0)	32	R/W	0000_0000h	37.3.2/935
4003_7104	Current Timer Value Register (PIT_CVAL0)	32	R/W	0000_0000h	37.3.3/935
4003_7108	Timer Control Register (PIT_TCTRL0)	32	R/W	0000_0000h	37.3.4/936
4003_710C	Timer Flag Register (PIT_TFLG0)	32	R/W	0000_0000h	37.3.5/936
4003_7110	Timer Load Value Register (PIT_LDVAL1)	32	R/W	0000_0000h	37.3.2/935
4003_7114	Current Timer Value Register (PIT_CVAL1)	32	R/W	0000_0000h	37.3.3/935
4003_7118	Timer Control Register (PIT_TCTRL1)	32	R/W	0000_0000h	37.3.4/936
4003_711C	Timer Flag Register (PIT_TFLG1)	32	R/W	0000_0000h	37.3.5/936
4003_7120	Timer Load Value Register (PIT_LDVAL2)	32	R/W	0000_0000h	37.3.2/935
4003_7124	Current Timer Value Register (PIT_CVAL2)	32	R/W	0000_0000h	37.3.3/935
4003_7128	Timer Control Register (PIT_TCTRL2)	32	R/W	0000_0000h	37.3.4/936
4003_712C	Timer Flag Register (PIT_TFLG2)	32	R/W	0000_0000h	37.3.5/936

Table continues on the next page...

PIT memory map (continued)

Absolute address (hex)	Register name	Width (in bits)	Access	Reset value	Section/page
4003_7130	Timer Load Value Register (PIT_LDVAL3)	32	R/W	0000_0000h	37.3.2/935
4003_7134	Current Timer Value Register (PIT_CVAL3)	32	R/W	0000_0000h	37.3.3/935
4003_7138	Timer Control Register (PIT_TCTRL3)	32	R/W	0000_0000h	37.3.4/936
4003_713C	Timer Flag Register (PIT_TFLG3)	32	R/W	0000_0000h	37.3.5/936

37.3.1 PIT Module Control Register (PIT_MCR)

This register controls whether the timer clocks should be enabled and whether the timers should run in debug mode.

Address: PIT_MCR is 4003_7000h base + 0h offset = 4003_7000h

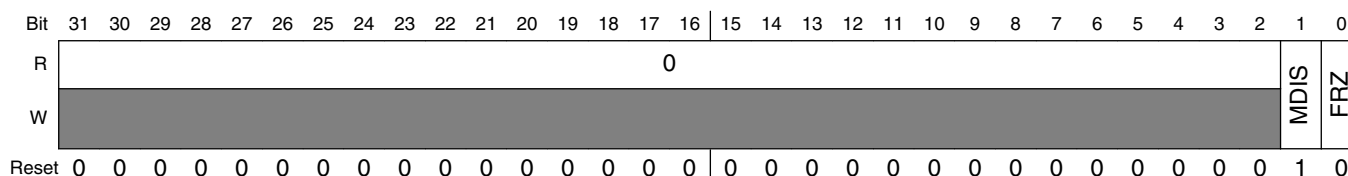

PIT_MCR field descriptions

Field	Description
31–2 Reserved	This read-only field is reserved and always has the value zero.
1 MDIS	Module Disable This is used to disable the module clock. This bit must be enabled before any other setup is done. 0 Clock for PIT Timers is enabled. 1 Clock for PIT Timers is disabled.
0 FRZ	Freeze Allows the timers to be stopped when the device enters debug mode. 0 Timers continue to run in debug mode. 1 Timers are stopped in debug mode.

37.3.2 Timer Load Value Register (PIT_LDVALn)

These registers select the timeout period for the timer interrupts.

Addresses: PIT_LDVAL0 is 4003_7000h base + 100h offset = 4003_7100h

PIT_LDVAL1 is 4003_7000h base + 110h offset = 4003_7110h

PIT_LDVAL2 is 4003_7000h base + 120h offset = 4003_7120h

PIT_LDVAL3 is 4003_7000h base + 130h offset = 4003_7130h

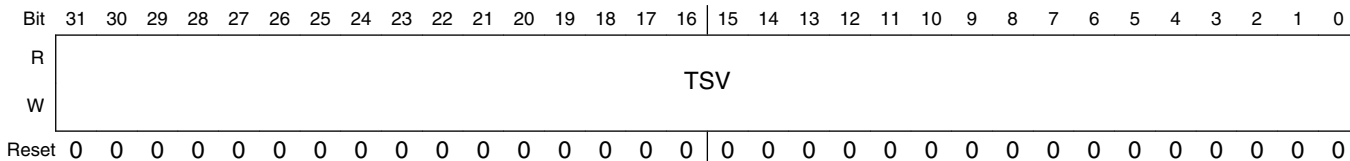

PIT_LDVALn field descriptions

Field	Description
31–0 TSV	<p>Timer Start Value Bits</p> <p>These bits set the timer start value. The timer will count down until it reaches 0, then it will generate an interrupt and load this register value again. Writing a new value to this register will not restart the timer, instead the value will be loaded once the timer expires. To abort the current cycle and start a timer period with the new value, the timer must be disabled and enabled again.</p>

37.3.3 Current Timer Value Register (PIT_CVALn)

These registers indicate the current timer position.

Addresses: PIT_CVAL0 is 4003_7000h base + 104h offset = 4003_7104h

PIT_CVAL1 is 4003_7000h base + 114h offset = 4003_7114h

PIT_CVAL2 is 4003_7000h base + 124h offset = 4003_7124h

PIT_CVAL3 is 4003_7000h base + 134h offset = 4003_7134h

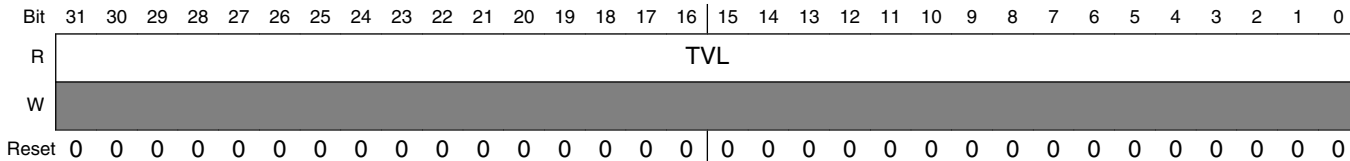

PIT_CVALn field descriptions

Field	Description
31–0 TVL	<p>Current Timer Value</p> <p>If the timer is enabled, these bits represent the current timer value. If the timer is disabled, do not use this field as its value is unreliable.</p> <p>NOTE: The timer uses a downcounter. The timer values are frozen in debug mode if the MCR[FRZ] bit is set.</p>

37.3.4 Timer Control Register (PIT_TCTRLn)

These register contain the control bits for each timer.

Addresses: PIT_TCTRL0 is 4003_7000h base + 108h offset = 4003_7108h

PIT_TCTRL1 is 4003_7000h base + 118h offset = 4003_7118h

PIT_TCTRL2 is 4003_7000h base + 128h offset = 4003_7128h

PIT_TCTRL3 is 4003_7000h base + 138h offset = 4003_7138h

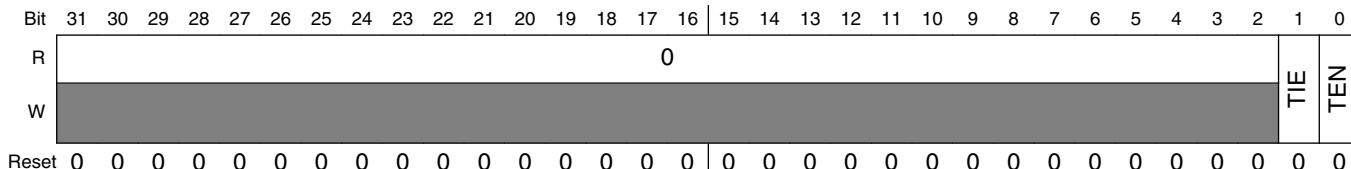

PIT_TCTRLn field descriptions

Field	Description
31–2 Reserved	This read-only field is reserved and always has the value zero.
1 TIE	<p>Timer Interrupt Enable Bit.</p> <p>When an interrupt is pending (TIF set), enabling the interrupt will immediately cause an interrupt event. To avoid this, the associated TIF flag must be cleared first.</p> <p>0 Interrupt requests from Timer n are disabled. 1 Interrupt will be requested whenever TIF is set.</p>
0 TEN	<p>Timer Enable Bit.</p> <p>This bit enables or disables the timer.</p> <p>0 Timer n is disabled. 1 Timer n is active.</p>

37.3.5 Timer Flag Register (PIT_TFLGn)

These registers hold the PIT interrupt flags.

Addresses: PIT_TFLG0 is 4003_7000h base + 10Ch offset = 4003_710Ch

PIT_TFLG1 is 4003_7000h base + 11Ch offset = 4003_711Ch

PIT_TFLG2 is 4003_7000h base + 12Ch offset = 4003_712Ch

PIT_TFLG3 is 4003_7000h base + 13Ch offset = 4003_713Ch

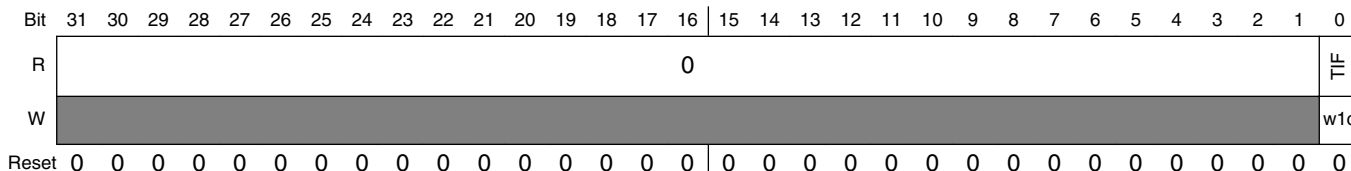

PIT_TFLGn field descriptions

Field	Description
31–1 Reserved	This read-only field is reserved and always has the value zero.
0 TIF	<p>Timer Interrupt Flag.</p> <p>TIF is set to 1 at the end of the timer period. This flag can be cleared only by writing it with 1. Writing 0 has no effect. If enabled (TIE = 1), TIF causes an interrupt request.</p> <p>0 Time-out has not yet occurred. 1 Time-out has occurred.</p>

37.4 Functional Description

This section provides the functional description of the module.

37.4.1 General

This section gives detailed information on the internal operation of the module. Each timer can be used to generate trigger pulses as well as to generate interrupts. Each interrupt is available on a separate interrupt line.

37.4.1.1 Timers

The timers generate triggers at periodic intervals, when enabled. They load their start values, as specified in their LDVAL registers, then count down until they reach 0. Then they load their respective start value again. Each time a timer reaches 0, it will generate a trigger pulse and set the interrupt flag.

All interrupts can be enabled or masked (by setting the TIE bits in the TCTRL registers). A new interrupt can be generated only after the previous one is cleared.

If desired, the current counter value of the timer can be read via the CVAL registers.

The counter period can be restarted, by first disabling, then enabling the timer with the TEN bit (see the following figure).

Functional Description

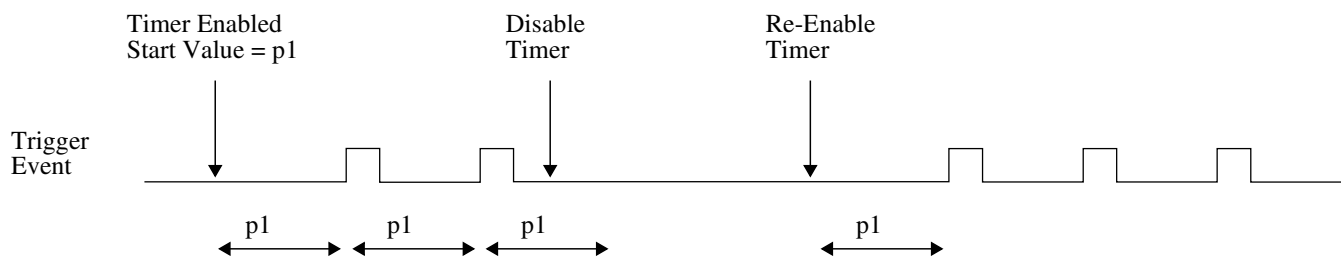

Figure 37-23. Stopping and Starting a Timer

The counter period of a running timer can be modified, by first disabling the timer, setting a new load value and then enabling the timer again (see the following figure).

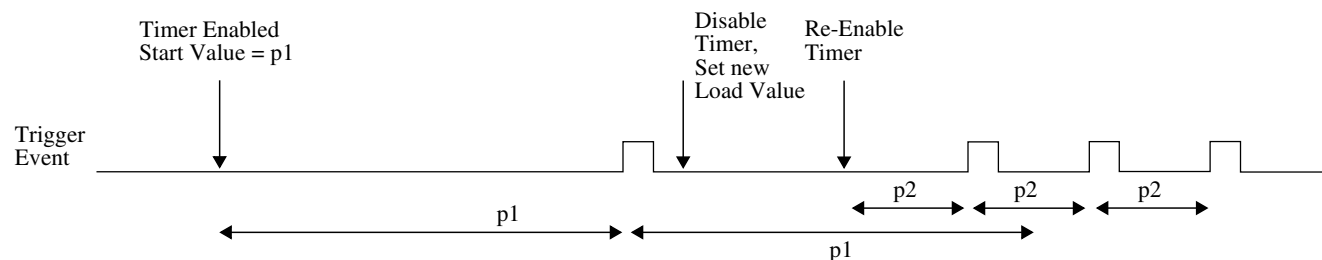

Figure 37-24. Modifying Running Timer Period

It is also possible to change the counter period without restarting the timer by writing the LDVAL register with the new load value. This value will then be loaded after the next trigger event (see the following figure).

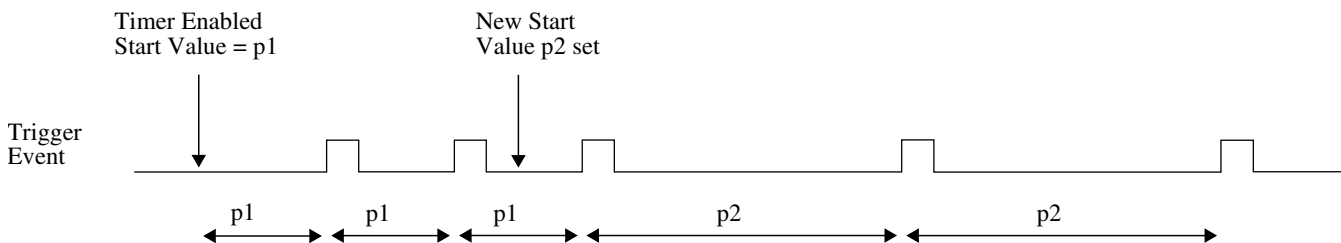

Figure 37-25. Dynamically Setting a New Load Value

37.4.1.2 Debug Mode

In debug mode, the timers will be frozen based on FRZ bit in PIT module control register. This is intended to aid software development, allowing the developer to halt the processor, investigate the current state of the system (for example, the timer values) and then continue the operation.

37.4.2 Interrupts

All of the timers support interrupt generation. Refer to the MCU specification for related vector addresses and priorities.

Timer interrupts can be enabled by setting the TIE bits. The timer interrupt flags (TIF) are set to 1 when a timeout occurs on the associated timer, and are cleared to 0 by writing a 1 to that TIF bit.

37.5 Initialization and Application Information

In the example configuration:

- The PIT clock has a frequency of 50 MHz.
- Timer 1 creates an interrupt every 5.12 ms.
- Timer 3 creates a trigger event every 30 ms.

First the PIT module must be activated by writing a 0 to the MDIS bit in the MCR.

The 50 MHz clock frequency equates to a clock period of 20 ns. Timer 1 needs to trigger every 5.12 ms/20 ns = 256000 cycles and timer 3 every 30 ms/20 ns = 1500000 cycles. The value for the LDVAL register trigger is calculated as:

$LDVAL \text{ trigger} = (\text{period} / \text{clock period}) - 1$

This means LDVAL1 should be written with 0x0003E7FF, and LDVAL3 should be written with 0x0016E35F.

The interrupt for Timer 1 is enabled by setting TIE in the TCTRL1 register. The timer is started by writing 1 to bit TEN in the TCTRL1 register.

Timer 3 shall be used only for triggering. Therefore Timer 3 is started by writing a 1 to bit TEN in the TCTRL3 register, bit TIE stays at 0.

The following example code matches the described setup:

```
// turn on PIT
PIT_MCR = 0x00;

// Timer 1
PIT_LDVAL1 = 0x0003E7FF; // setup timer 1 for 256000 cycles
PIT_TCTRL1 = TIE; // enable Timer 1 interrupts
PIT_TCTRL1 |= TEN; // start Timer 1

// Timer 3
```

Initialization and Application Information

```
PIT_LDVAL3 = 0x0016E35F; // setup timer 3for 1500000 cycles  
PIT_TCTRL3 |= TEN; // start Timer 3
```

Chapter 38

Low power timer (LPTMR)

38.1 Introduction

NOTE

For the chip-specific implementation details of this module's instances see the chip configuration chapter.

The low power timer (LPTMR) can be configured to operate as a time counter (with optional prescaler) or as a pulse counter (with optional glitch filter) across all power modes, including the low leakage modes. It can also continue operating through most system reset events, allowing it to be used as a time of day counter.

38.1.1 Features

The LPTMR module's features include:

- 16-bit time counter or pulse counter with compare
 - Optional interrupt can generate asynchronous wakeup from any low power mode
 - Hardware trigger output
 - Counter supports free-running mode or reset on compare
- Configurable clock source for prescaler/glitch filter
- Configurable input source for pulse counter
 - Rising edge or falling edge

38.1.2 Modes of operation

38.1.2.1 Run mode

In run mode, the LPTMR operates normally.

38.1.2.2 Wait mode

In wait mode, the LPTMR continues to operate normally and may be configured to exit the low power mode by generating an interrupt request.

38.1.2.3 Stop mode

In stop mode, the LPTMR continues to operate normally and may be configured to exit the low power mode by generating an interrupt request.

38.1.2.4 Low leakage modes

In low leakage modes, the LPTMR continues to operate normally and may be configured to exit the low power mode by generating an interrupt request.

38.1.2.5 Debug modes

In debug mode, the LPTMR operates normally.

38.2 LPTMR signal descriptions

Table 38-1. LPTMR signal descriptions

Signal	Description	I/O
LPTMR_ALT <i>n</i>	Pulse counter input pin	I

38.2.1 Detailed signal descriptions

Table 38-2. LPTMR interface-detailed signal descriptions

Signal	I/O	Description	
LPTMR_ALT n	I	Pulse counter input. The LPTMR can select one of the input pins to be used in pulse counter mode.	
		State meaning	Assertion-If configured for pulse counter mode with active high input then assertion causes the LPTMR counter register to increment. Negation-If configured for pulse counter mode with active low input then negation cause the LPTMR counter register to increment.
		Timing	Assertion or negation may occur at any time; input may assert asynchronously to the bus clock.

38.3 Memory map and register definition

NOTE

The LPTMR registers are reset only on a POR or LVD event.
See [LPTMR power and reset](#) for more details.

LPTMR memory map

Absolute address (hex)	Register name	Width (in bits)	Access	Reset value	Section/page
4004_0000	Low Power Timer Control Status Register (LPTMR0_CSR)	32	R/W	0000_0000h	38.3.1/944
4004_0004	Low Power Timer Prescale Register (LPTMR0_PSR)	32	R/W	0000_0000h	38.3.2/945
4004_0008	Low Power Timer Compare Register (LPTMR0_CMR)	32	R/W	0000_0000h	38.3.3/947
4004_000C	Low Power Timer Counter Register (LPTMR0_CNR)	32	R	0000_0000h	38.3.4/947

38.3.1 Low Power Timer Control Status Register (LPTMRx_CSR)

Addresses: LPTMR0_CSR is 4004_0000h base + 0h offset = 4004_0000h

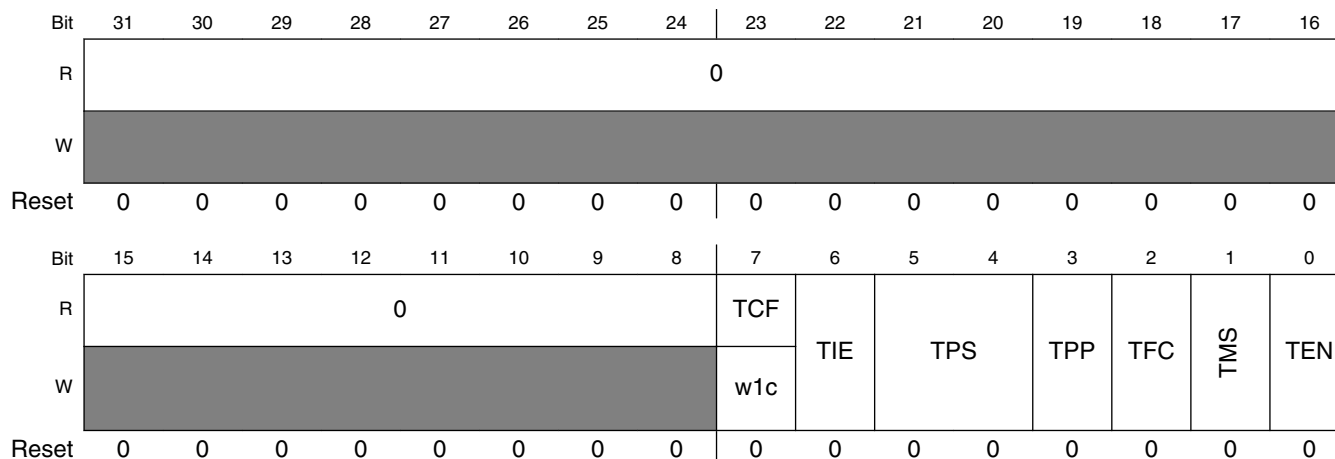

LPTMRx_CSR field descriptions

Field	Description
31–8 Reserved	This read-only field is reserved and always has the value zero.
7 TCF	<p>Timer Compare Flag</p> <p>The timer compare flag is set when the LPTMR is enabled and the LPTMR Counter Register equals the LPTMR Compare Register and increments. This Timer Compare Flag is cleared when the LPTMR is disabled or a logic one is written to the Timer Compare Flag.</p> <p>0 LPTMR Counter Register has not equaled the LPTMR Compare Register and incremented 1 LPTMR Counter Register has equaled the LPTMR Compare Register and incremented</p>
6 TIE	<p>Timer Interrupt Enable</p> <p>When the Timer Interrupt Enable is set, the LPTMR Interrupt is generated whenever the Timer Compare Flag is also set.</p> <p>0 Timer Interrupt Disabled. 1 Timer Interrupt Enabled.</p>
5–4 TPS	<p>Timer Pin Select</p> <p>The Timer Pin Select configures the input source to be used in Pulse Counter mode. The Timer Pin Select should only be altered when the LPTMR is disabled. The input connections vary by device. See the Chip Configuration details for information on the connections to these inputs.</p> <p>00 Pulse counter input 0 is selected. 01 Pulse counter input 1 is selected. 10 Pulse counter input 2 is selected. 11 Pulse counter input 3 is selected.</p>
3 TPP	Timer Pin Polarity

Table continues on the next page...

LPTMRx_CSR field descriptions (continued)

Field	Description
	<p>The Timer Pin Polarity configures the polarity of the input source in Pulse Counter mode. The Timer Pin Polarity should only be changed when the LPTMR is disabled.</p> <p>0 Pulse Counter input source is active high, and LPTMR Counter Register will increment on the rising edge.</p> <p>1 Pulse Counter input source is active low, and LPTMR Counter Register will increment on the falling edge.</p>
2 TFC	<p>Timer Free Running Counter</p> <p>When clear the Timer Free Running Counter configures the LPTMR Counter Register to reset whenever the Timer Compare Flag is set. When set, the Timer Free Running Counter configures the LPTMR Counter Register to reset on overflow. The Timer Free Running Counter should only be altered when the LPTMR is disabled.</p> <p>0 LPTMR Counter Register is reset whenever the Timer Compare Flag is set.</p> <p>1 LPTMR Counter Register is reset on overflow.</p>
1 TMS	<p>Timer Mode Select</p> <p>The Timer Mode Select configures the mode of the LPTMR. The Timer Mode Select should only be altered when the LPTMR is disabled.</p> <p>0 Time Counter mode.</p> <p>1 Pulse Counter mode.</p>
0 TEN	<p>Timer Enable</p> <p>When the Timer Enable bit is clear, it resets the LPTMR internal logic (including the LPTMR Counter Register and Timer Compare Flag). When the Timer Enable bit is set, the LPTMR is enabled. When writing 1 to this bit, bits LPTMR_CSR[5:1] should not be altered.</p> <p>0 LPTMR is disabled and internal logic is reset.</p> <p>1 LPTMR is enabled.</p>

38.3.2 Low Power Timer Prescale Register (LPTMRx_PSR)

Addresses: LPTMR0_PSR is 4004_0000h base + 4h offset = 4004_0004h

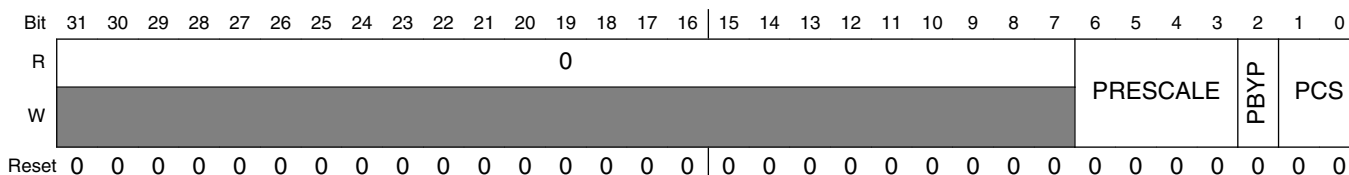

LPTMRx_PSR field descriptions

Field	Description
31–7 Reserved	This read-only field is reserved and always has the value zero.

Table continues on the next page...

LPTMRx_PSR field descriptions (continued)

Field	Description
6–3 PRESCALE	<p>Prescale Value</p> <p>The Prescaler Value register field configures the size of the Prescaler (in Time Counter mode) or width of the Glitch Filter (in Pulse Counter mode). The Prescale Value should only be altered when the LPTMR is disabled.</p> <p>0000 Prescaler divides the prescaler clock by 2; Glitch Filter does not support this configuration.</p> <p>0001 Prescaler divides the prescaler clock by 4; Glitch Filter recognizes change on input pin after 2 rising clock edges.</p> <p>0010 Prescaler divides the prescaler clock by 8; Glitch Filter recognizes change on input pin after 4 rising clock edges.</p> <p>0011 Prescaler divides the prescaler clock by 16; Glitch Filter recognizes change on input pin after 8 rising clock edges.</p> <p>0100 Prescaler divides the prescaler clock by 32; Glitch Filter recognizes change on input pin after 16 rising clock edges.</p> <p>0101 Prescaler divides the prescaler clock by 64; Glitch Filter recognizes change on input pin after 32 rising clock edges.</p> <p>0110 Prescaler divides the prescaler clock by 128; Glitch Filter recognizes change on input pin after 64 rising clock edges.</p> <p>0111 Prescaler divides the prescaler clock by 256; Glitch Filter recognizes change on input pin after 128 rising clock edges.</p> <p>1000 Prescaler divides the prescaler clock by 512; Glitch Filter recognizes change on input pin after 256 rising clock edges.</p> <p>1001 Prescaler divides the prescaler clock by 1024; Glitch Filter recognizes change on input pin after 512 rising clock edges.</p> <p>1010 Prescaler divides the prescaler clock by 2048; Glitch Filter recognizes change on input pin after 1024 rising clock edges.</p> <p>1011 Prescaler divides the prescaler clock by 4096; Glitch Filter recognizes change on input pin after 2048 rising clock edges.</p> <p>1100 Prescaler divides the prescaler clock by 8192; Glitch Filter recognizes change on input pin after 4096 rising clock edges.</p> <p>1101 Prescaler divides the prescaler clock by 16384; Glitch Filter recognizes change on input pin after 8192 rising clock edges.</p> <p>1110 Prescaler divides the prescaler clock by 32768; Glitch Filter recognizes change on input pin after 16384 rising clock edges.</p> <p>1111 Prescaler divides the prescaler clock by 65536; Glitch Filter recognizes change on input pin after 32768 rising clock edges.</p>
2 PBYP	<p>Prescaler Bypass</p> <p>When the Prescaler Bypass is set the selected prescaler clock (in Time Counter mode) or selected input source (in Pulse Counter mode) directly clocks the LPTMR Counter Register. When the Prescaler Bypass is clear, the LPTMR Counter Register is clocked by the output of the prescaler/glitch filter. The Prescaler Bypass should only be altered when the LPTMR is disabled.</p> <p>0 Prescaler/Glitch Filter is enabled.</p> <p>1 Prescaler/Glitch Filter is bypassed.</p>
1–0 PCS	<p>Prescaler Clock Select</p> <p>The Prescaler Clock Select selects the clock to be used by the LPTMR prescaler/glitch filter. The Prescaler Clock Select should only be altered when the LPTMR is disabled. The clock connections vary by device. See the Chip Configuration details for information on the connections to these inputs.</p>

Table continues on the next page...

LPTMRx_PSR field descriptions (continued)

Field	Description
00	Prescaler/glitch filter clock 0 selected
01	Prescaler/glitch filter clock 1 selected
10	Prescaler/glitch filter clock 2 selected
11	Prescaler/glitch filter clock 3 selected

38.3.3 Low Power Timer Compare Register (LPTMRx_CMCR)

Addresses: LPTMR0_CMCR is 4004_0000h base + 8h offset = 4004_0008h

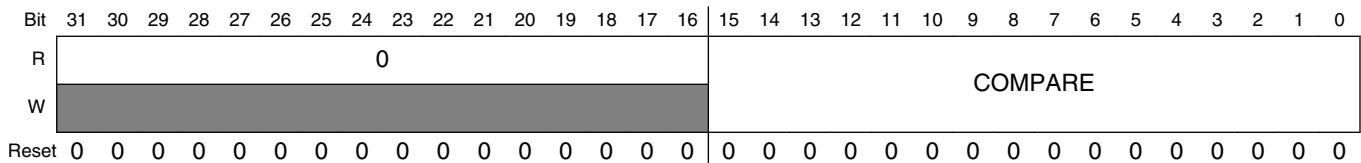

LPTMRx_CMCR field descriptions

Field	Description
31–16 Reserved	This read-only field is reserved and always has the value zero.
15–0 COMPARE	Compare Value When the LPTMR is enabled and the LPTMR Counter Register equals the value in the LPTMR Compare Register and increments, the Timer Compare Flag is set and the Hardware Trigger asserts until the next time the LPTMR Counter Register increments. If the LPTMR Compare Register is zero, the Hardware Trigger will remain asserted until the LPTMR is disabled. If the LPTMR is enabled, the LPTMR Compare Register should only be altered when the Timer Compare Flag is set.

38.3.4 Low Power Timer Counter Register (LPTMRx_CNR)

Addresses: LPTMR0_CNR is 4004_0000h base + Ch offset = 4004_000Ch

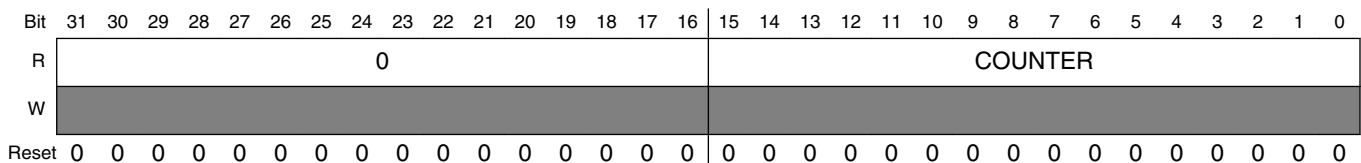

LPTMRx_CNR field descriptions

Field	Description
31–16 Reserved	This read-only field is reserved and always has the value zero.

Table continues on the next page...

LPTMRx_CNR field descriptions (continued)

Field	Description
15–0 COUNTER	Counter Value The LPTMR Counter Register returns the current value of the LPTMR Counter.

38.4 Functional description

38.4.1 LPTMR power and reset

The LPTMR remains powered in all power modes, including low leakage modes. If the LPTMR is not required to remain operating during a low power mode, then it should be disabled before entering the mode.

The LPTMR is reset only on global POR or LVD. When configuring the LPTMR registers, the control status register should be initially written with the timer disabled, before configuring the LPTMR prescale register and compare register. The timer enable should then be set as the last step in the initialization. This ensures the LPTMR is configured correctly and the LPTMR counter is reset to zero following a warm reset.

38.4.2 LPTMR clocking

The LPTMR prescaler/glitch filter can be clocked by one of four clocks. The clock source should be enabled before the LPTMR is enabled.

NOTE

The clock source selected may need to be configured to remain enabled in low power modes, otherwise the LPTMR will not operate during low power modes.

In pulse counter mode with the prescaler/glitch filter bypassed, the selected input source directly clocks the LPTMR counter register and no other clock source is required. To minimize power in this case, configure the prescaler clock source for a clock that is not toggling.

NOTE

The clock source or pulse input source selected for the LPTMR should not exceed the frequency f_{LPTMR} defined in the device datasheet.

38.4.3 LPTMR prescaler/glitch filter

The LPTMR prescaler and glitch filter share the same logic which operates as a prescaler in time counter mode and as a glitch filter in pulse counter mode.

The prescaler/glitch filter configuration must not be altered when the LPTMR is enabled.

38.4.3.1 Prescaler enabled

In time counter mode when the prescaler is enabled, the output of the prescaler directly clocks the LPTMR counter register. When the LPTMR is enabled, the LPTMR counter register will increment every 2^2 to 2^{16} prescaler clock cycles. After the LPTMR is enabled, the first increment of the LPTMR counter register will take an additional one or two prescaler clock cycles due to synchronization logic.

38.4.3.2 Prescaler bypassed

In time counter mode when the prescaler is bypassed, the selected prescaler clock increments the LPTMR counter register on every clock cycle. When the LPTMR is enabled, the first increment will take an additional one or two prescaler clock cycles due to synchronization logic.

38.4.3.3 Glitch filter

In pulse counter mode when the glitch filter is enabled, the output of the glitch filter directly clocks the LPTMR counter register. When the LPTMR is first enabled, the output of the glitch filter is asserted (logic one for active high and logic zero for active low). If the selected input source remains negated for at least 2^1 to 2^{15} consecutive prescaler clock rising edges, then the glitch filter output will also negate. If the selected input source remains asserted for at least 2^1 to 2^{15} consecutive prescaler clock rising edges, then the glitch filter output will also assert. Note that the input is only sampled on the rising clock edge.

The LPTMR counter register will increment each time the glitch filter output asserts. In pulse counter mode, the maximum rate at which the LPTMR counter register can increment is once every 2^2 to 2^{16} prescaler clock edges. When first enabled, the glitch filter will wait an additional one or two prescaler clock edges due to synchronization logic.

38.4.3.4 Glitch filter bypassed

In pulse counter mode when the glitch filter is bypassed, the selected input source increments the LPTMR counter register every time it asserts. Before the LPTMR is first enabled, the selected input source is forced to assert. This is to prevent the LPTMR counter register from incrementing if the selected input source is already asserted when the LPTMR is first enabled.

38.4.4 LPTMR compare

When the LPTMR counter register equals the value of the LPTMR compare register and increments, the following events occur:

- Timer compare flag is set
- LPTMR interrupt is generated if Timer Interrupt Enable is also set
- LPTMR hardware trigger is generated
- LPTMR counter register is reset if the free running counter bit is clear

When the LPTMR is enabled, the LPTMR compare register can only be altered when the timer compare flag is set. When updating the LPTMR compare register, the LPTMR compare register must be written and the timer compare flag must be cleared before the LPTMR counter has incremented past the new LPTMR compare value.

38.4.5 LPTMR counter

The LPTMR counter register increments by one on every:

- prescaler clock (time counter mode with prescaler bypassed)
- prescaler output (time counter mode with prescaler enabled)
- input source assertion (pulse counter mode with glitch filter bypassed)
- glitch filter output (pulse counter mode with glitch filter enabled).

The LPTMR counter register is reset when the LPTMR is disabled or if the counter register overflows. If the CSR[TFC] control bit is set then the LPTMR counter register is also reset whenever the CSR[TCF] status flag is set.

The LPTMR counter register continues incrementing when the core is halted in debug mode.

The LPTMR counter register cannot be initialized, but can be read at any time. Reading the LPTMR counter register at the same time as it is incrementing may return invalid data due to synchronization of the read data bus. If it is necessary for software to read the LPTMR counter register, it is recommended that two read accesses are performed and software verifies that the same data was returned for both reads.

38.4.6 LPTMR hardware trigger

The LPTMR hardware trigger asserts at the same time the timer compare flag is set and can be used to trigger hardware events in other peripherals without software intervention. The hardware trigger is always enabled.

When the LPTMR compare register is set to zero with the free running counter bit clear, the LPTMR hardware trigger will assert on the first compare and does not negate. When the LPTMR compare register is set to a non-zero value (or if the free running counter bit is set) the LPTMR hardware trigger will assert on each compare and negate on the following increment of the LPTMR counter register.

38.4.7 LPTMR interrupt

The LPTMR interrupt is generated whenever the CSR[TIE] and CSR[TCF] are set. The CSR[TCF] is cleared by disabling the LPTMR or by writing a logic one to it.

The CSR[TIE] can be altered and the CSR[TCF] can be cleared while the LPTMR is enabled.

The LPTMR interrupt is generated asynchronously to the system clock and can be used to generate a wakeup from any low power mode, including the low leakage modes (provided the LPTMR is enabled as a wakeup source).

Chapter 39

Carrier Modulator Transmitter (CMT)

39.1 Introduction

NOTE

For the chip-specific implementation details of this module's instances see the chip configuration chapter.

The carrier modulator transmitter (CMT) module provides means to generate the protocol timing and carrier signals for a wide variety of encoding schemes. The CMT incorporates hardware to off-load the critical and/or lengthy timing requirements associated with signal generation from the CPU, releasing much of its bandwidth to handle other tasks such as code data generation, data decompression, or keyboard scanning. The CMT does not include dedicated hardware configurations for specific protocols but is intended to be sufficiently programmable in its function to handle the timing requirements of most protocols with minimal CPU intervention. When the modulator is disabled, certain CMT registers can be used to change the state of the infrared output (CMT_IRO) signal directly. This feature allows for the generation of future protocol timing signals not readily producible by the current architecture.

39.2 Features

The features of this module include:

- Four modes of operation
 - Time; with independent control of high and low times
 - Baseband
 - Frequency shift key (FSK)
 - Direct software control of CMT_IRO signal

Block Diagram

- Extended space operation in time, baseband, and FSK modes
- Selectable input clock divider
- Interrupt on end of cycle
 - Ability to disable CMT_IRO signal and use as timer interrupt

39.3 Block Diagram

The following figure is the CMT block diagram.

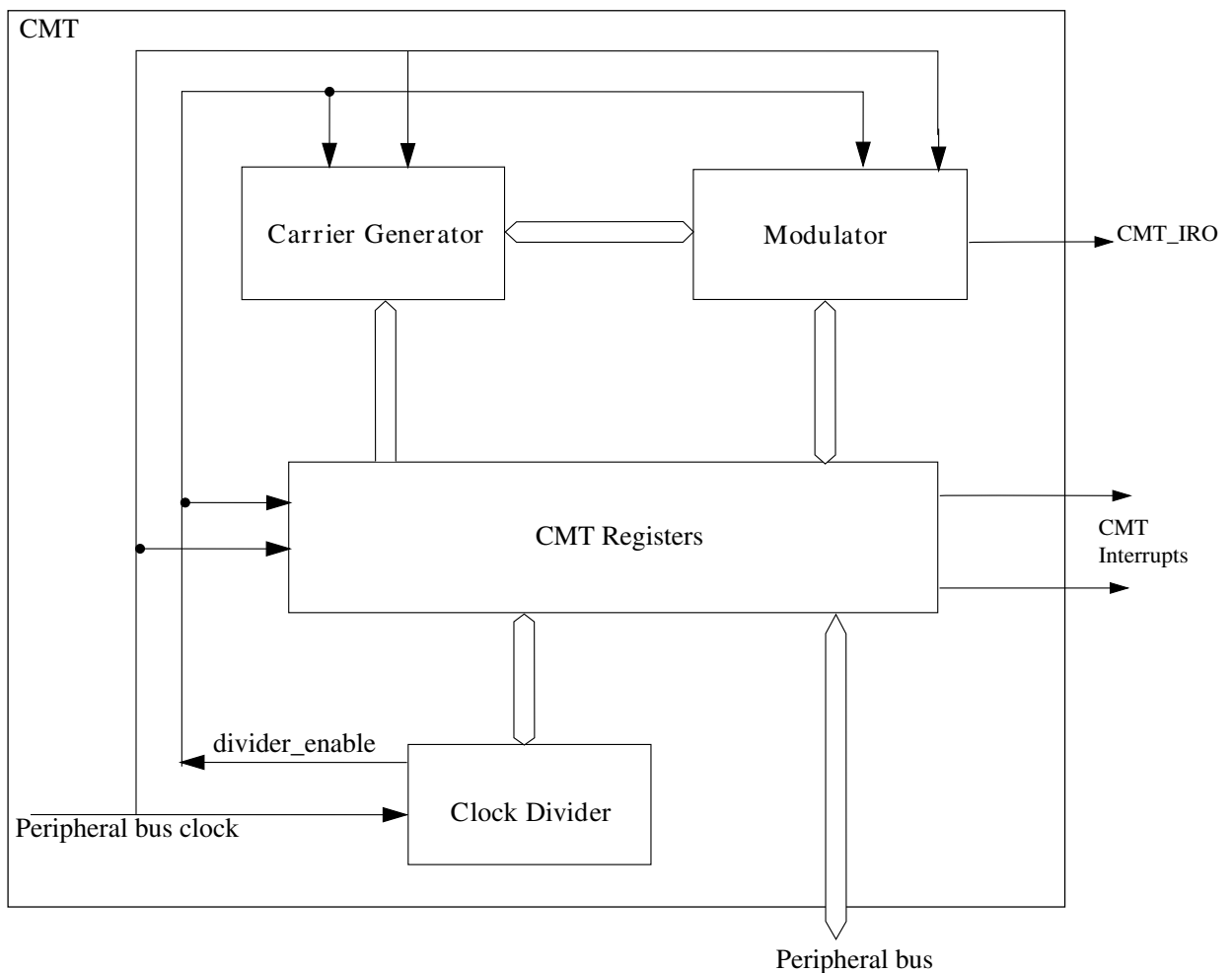

Figure 39-1. CMT Module Block Diagram

39.4 Modes of Operation

The CMT module operates in the following modes.

- **Time**—When operating in time mode, the user independently defines the high and low times of the carrier signal to determine both period and duty cycle.
- **Baseband**—When MSC[BASE] bit is set, the carrier output (f_{cg}) to the modulator is held high continuously to allow for the generation of baseband protocols.
- **Frequency shift key (FSK)**—This mode allows the carrier generator to alternate between two sets of high and low times. When operating in FSK mode, the generator will toggle between the two sets when instructed by the modulator, allowing the user to dynamically switch between two carrier frequencies without CPU intervention.

The following table summarizes the CMT's modes.

Table 39-1. CMT Modes of Operation

Mode	MSC[MCGEN] ¹	MSC[BASE] ²	MSC[FSK] ²	MSC[EXSPC]	Comment
Time	1	0	0	0	f_{cg} controlled by primary high and low registers. f_{cg} transmitted to CMT_IRO signal when modulator gate is open.
Baseband	1	1	X	0	f_{cg} is always high. CMT_IRO signal high when modulator gate is open.
FSK	1	0	1	0	f_{cg} control alternates between primary high/low registers and secondary high/low registers. f_{cg} transmitted to CMT_IRO signal when modulator gate is open.
Extended Space	1	X	X	1	Setting MSC[EXSPC] bit causes subsequent modulator cycles to be spaces (modulator out not asserted) for the duration of the modulator period (mark and space times).
IRO Latch	0	X	X	X	OC[IROL] bit controls state of CMT_IRO signal.

1. To prevent spurious operation, initialize all data and control registers before beginning a transmission (MSC[MCGEN]=1).
2. These bits are not double buffered and should not be changed during a transmission (while MSC[MCGEN]=1).

NOTE

The assignment of module modes to core modes is chip-specific. For module-to-core mode assignments, see the chapter that describes how modules are configured.

39.4.1 Wait Mode Operation

During wait mode, the CMT if enabled, will continue to operate normally. However, there is no change in operating modes of CMT while in wait mode, because the CPU is not operating.

39.4.2 Stop Mode Operation

This section describes the CMT stop mode operations.

39.4.2.1 Normal Stop Mode Operation

During Normal Stop mode, clocks to the CMT module are halted. No registers are affected.

Because the clocks are halted, the CMT will resume upon exit from Normal Stop. Software should ensure that the Normal Stop mode is not entered while the modulator is still in operation to prevent the CMT_IRO signal from being asserted while in Normal Stop mode. This may require a time-out period from the time that MSC[MCGEN] bit is cleared to allow the last modulator cycle to complete.

39.4.2.2 Low Power Stop Mode Operation

During Low Power Stop mode, the CMT module is completely powered off internally and the CMT_IRO signal state at the time that Low Power Stop mode is entered is latched and held. To prevent the CMT_IRO signal from being asserted while in Low Power Stop mode, software should assure that the signal is not active when entering Low Power Stop mode. Upon wake-up from Low Power Stop mode, the CMT module will be in the reset state.

39.5 CMT External Signal Descriptions

This table shows the description of the external signal.

Table 39-2. CMT Signal Descriptions

Signal	Description	I/O
CMT_IRO	Infrared Output	O

39.5.1 CMT_IRO — Infrared Output

This output signal is driven by the modulator output when MSC[MCGEN] is set and OC[IROPEN] is set. The CMT_IRO signal starts a valid transmission with a delay, after MSC[MCGEN] bit be asserted to high, that can be calculated based on two register bits. The following table shows how to calculate this delay.

If MSC[MCGEN] bit is cleared and OC[IROPEN] bit is set, the signal is driven by OC[IROL] bit. This enables user software to directly control the state of the CMT_IRO signal by writing to OC[IROL] bit. If OC[IROPEN] bit is cleared, the signal is disabled and is not driven by the CMT module. Therefore, CMT can be configured as a modulo timer for generating periodic interrupts without causing signal activity.

Table 39-3. CMT_IRO signal delay calculation

Condition	Delay (bus clock cycles)
MSC[CMTDIV] = 0	PPS[PPSDIV] + 2
MSC[CMTDIV] > 0	(PPS[PPSDIV] × 2) + 3

39.6 Memory Map/Register Definition

The following registers control and monitor CMT operation.

The address of a register is the sum of a base address and an address offset. The base address is defined at the chip level. The address offset is defined at the module level.

CMT memory map

Absolute address (hex)	Register name	Width (in bits)	Access	Reset value	Section/page
4006_2000	CMT Carrier Generator High Data Register 1 (CMT_CGH1)	8	R/W	Undefined	39.6.1/ 958
4006_2001	CMT Carrier Generator Low Data Register 1 (CMT_CGL1)	8	R/W	Undefined	39.6.2/ 959
4006_2002	CMT Carrier Generator High Data Register 2 (CMT_CGH2)	8	R/W	Undefined	39.6.3/ 960
4006_2003	CMT Carrier Generator Low Data Register 2 (CMT_CGL2)	8	R/W	Undefined	39.6.4/ 960
4006_2004	CMT Output Control Register (CMT_OC)	8	R/W	00h	39.6.5/ 961
4006_2005	CMT Modulator Status and Control Register (CMT_MSC)	8	R/W	00h	39.6.6/ 962
4006_2006	CMT Modulator Data Register Mark High (CMT_CMD1)	8	R/W	Undefined	39.6.7/ 963
4006_2007	CMT Modulator Data Register Mark Low (CMT_CMD2)	8	R/W	Undefined	39.6.8/ 964
4006_2008	CMT Modulator Data Register Space High (CMT_CMD3)	8	R/W	Undefined	39.6.9/ 964
4006_2009	CMT Modulator Data Register Space Low (CMT_CMD4)	8	R/W	Undefined	39.6.10/ 965
4006_200A	CMT Primary Prescaler Register (CMT_PPS)	8	R/W	00h	39.6.11/ 965
4006_200B	CMT Direct Memory Access (CMT_DMA)	8	R/W	00h	39.6.12/ 966

39.6.1 CMT Carrier Generator High Data Register 1 (CMT_CGH1)

This data register contain the primary high value for generating the carrier output.

Address: CMT_CGH1 is 4006_2000h base + 0h offset = 4006_2000h

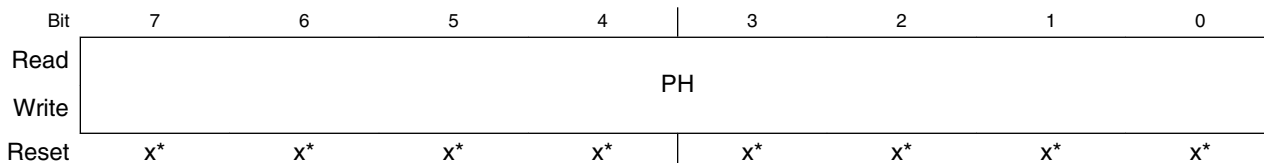

* Notes:

- x = Undefined at reset.

CMT_CGH1 field descriptions

Field	Description
7-0 PH	<p>Primary Carrier High Time Data Value</p> <p>When selected, these bits contain the number of input clocks required to generate the carrier high time period. When operating in Time mode, this register is always selected. When operating in FSK mode, this register and the secondary register pair are alternately selected under control of the modulator. The primary carrier high time value is undefined out of reset. These bits must be written to non-zero values before the carrier generator is enabled to avoid spurious results.</p>

39.6.2 CMT Carrier Generator Low Data Register 1 (CMT_CGL1)

This data register contain the primary low value for generating the carrier output.

Address: CMT_CGL1 is 4006_2000h base + 1h offset = 4006_2001h

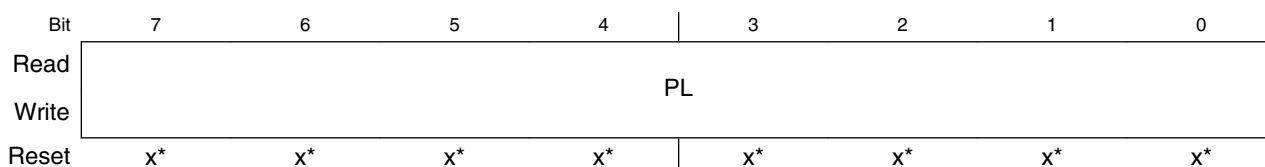

* Notes:

- x = Undefined at reset.

CMT_CGL1 field descriptions

Field	Description
7-0 PL	<p>Primary Carrier Low Time Data Value</p> <p>When selected, these bits contain the number of input clocks required to generate the carrier low time period. When operating in Time mode, this register is always selected. When operating in FSK mode, this register and the secondary register pair are alternately selected under control of the modulator. The primary carrier low time value is undefined out of reset. These bits must be written to non-zero values before the carrier generator is enabled to avoid spurious results.</p>

39.6.3 CMT Carrier Generator High Data Register 2 (CMT_CGH2)

This data register contain the secondary high value for generating the carrier output.

Address: CMT_CGH2 is 4006_2000h base + 2h offset = 4006_2002h

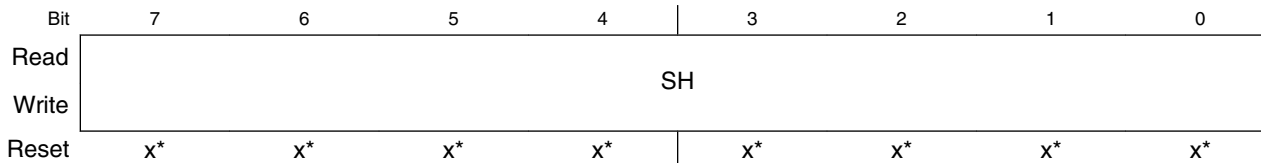

* Notes:

- x = Undefined at reset.

CMT_CGH2 field descriptions

Field	Description
7–0 SH	<p>Secondary Carrier High Time Data Value</p> <p>When selected, these bits contain the number of input clocks required to generate the carrier high time period. When operating in Time mode, this register is never selected. When operating in FSK mode, this register and the primary register pair are alternately selected under control of the modulator. The secondary carrier high time value is undefined out of reset. These bits must be written to nonzero values before the carrier generator is enabled when operating in FSK mode.</p>

39.6.4 CMT Carrier Generator Low Data Register 2 (CMT_CGL2)

This data register contain the secondary low value for generating the carrier output.

Address: CMT_CGL2 is 4006_2000h base + 3h offset = 4006_2003h

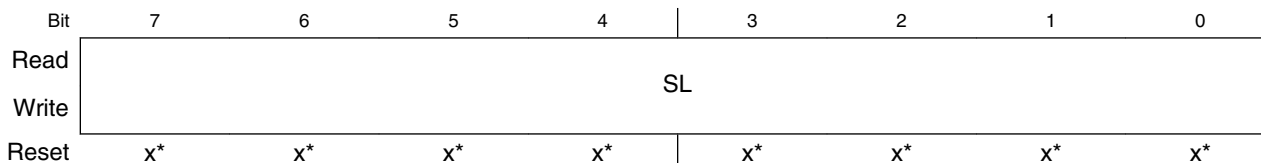

* Notes:

- x = Undefined at reset.

CMT_CGL2 field descriptions

Field	Description
7–0 SL	<p>Secondary Carrier Low Time Data Value</p> <p>When selected, these bits contain the number of input clocks required to generate the carrier low time period. When operating in Time mode, this register is never selected. When operating in FSK mode, this register and the primary register pair are alternately selected under control of the modulator. The secondary carrier low time value is undefined out of reset. These bits must be written to nonzero values before the carrier generator is enabled when operating in FSK mode.</p>

39.6.5 CMT Output Control Register (CMT_OC)

This register is used to control the IRO signal of the CMT module.

Address: CMT_OC is 4006_2000h base + 4h offset = 4006_2004h



CMT_OC field descriptions

Field	Description
7 IROL	<p>IRO Latch Control</p> <p>Reading IROL reads the state of the IRO latch. Writing to IROL changes the state of the CMT_IRO signal when MSC[MCGEN] bit is cleared and the IROPEN bit is set.</p>
6 CMPOL	<p>CMT Output Polarity</p> <p>The CMPOL bit controls the polarity of the CMT_IRO signal of the CMT.</p> <p>0 CMT_IRO signal is active low 1 CMT_IRO signal is active high</p>
5 IROPEN	<p>IRO Pin Enable</p> <p>The IROPEN bit is used to enable and disable the CMT_IRO signal. When CMT_IRO signal is enabled, it is an output that drives out either the CMT transmitter output or the state of the IROL bit depending on whether MSC[MCGEN] bit is set or not. Also, the state of the output is either inverted or not depending on the state of the CMPOL bit. When CMT_IRO signal is disabled, it is in a high impedance state so as not to draw any current. This signal is disabled during reset.</p> <p>0 CMT_IRO signal disabled 1 CMT_IRO signal enabled as output</p>
4-0 Reserved	<p>This read-only field is reserved and always has the value zero.</p>

39.6.6 CMT Modulator Status and Control Register (CMT_MSC)

The MSC register contains the modulator and carrier generator enable (MCGEN), end of cycle interrupt enable (EOCIE), FSK mode select (FSK), baseband enable (BASE), extended space (EXSPC), prescaler (CMTDIV) bits, and the end of cycle (EOCF) status bit.

Address: CMT_MSC is 4006_2000h base + 5h offset = 4006_2005h

Bit	7	6	5	4	3	2	1	0	
Read	EOCF	CMTDIV			EXSPC	BASE	FSK	EOCIE	MCGEN
Write									
Reset	0	0	0	0	0	0	0	0	

CMT_MSC field descriptions

Field	Description
7 EOCF	<p>End Of Cycle Status Flag</p> <p>The EOCF bit is set when:</p> <ul style="list-style-type: none"> The modulator is not currently active and the MCGEN bit is set to begin the initial CMT transmission. At the end of each modulation cycle while the MCGEN bit is set. This is recognized when a match occurs between the contents of the space period register and the down counter. At this time, the counter is initialized with the (possibly new) contents of the mark period buffer, CMT_CMD1 and CMT_CMD2, and the space period register is loaded with the (possibly new) contents of the space period buffer, CMT_CMD3 and CMT_CMD4. <p>This flag is cleared by a read of the MSC register followed by an access of CMD2 or CMD4 or by the DMA transfer.</p> <p>0 No end of modulation cycle occurrence since flag last cleared 1 End of modulator cycle has occurred</p>
6–5 CMTDIV	<p>CMT Clock Divide Prescaler</p> <p>The Secondary Prescaler causes the CMT to be clocked at the IF signal frequency, or the IF frequency divided by 2, 4, or 8. Since these bits are not double buffered, they should not be changed during a transmission.</p> <p>00 IF ÷ 1 01 IF ÷ 2 10 IF ÷ 4 11 IF ÷ 8</p>
4 EXSPC	<p>Extended Space Enable</p> <p>The EXSPC bit enables extended space operation.</p> <p>0 Extended space disabled 1 Extended space enabled</p>

Table continues on the next page...

CMT_MSC field descriptions (continued)

Field	Description
3 BASE	<p>Baseband Enable</p> <p>When set, the BASE bit disables the carrier generator and forces the carrier output high for generation of baseband protocols. When BASE is cleared, the carrier generator is enabled and the carrier output toggles at the frequency determined by values stored in the carrier data registers. This bit is cleared by reset. This bit is not double buffered and should not be written to during a transmission.</p> <p>0 Baseband mode disabled 1 Baseband mode enabled</p>
2 FSK	<p>FSK Mode Select</p> <p>The FSK bit enables FSK operation.</p> <p>0 CMT operates in Time or Baseband mode 1 CMT operates in FSK mode</p>
1 EOCIE	<p>End of Cycle Interrupt Enable</p> <p>A CPU interrupt will be requested when EOCF is set if EOCIE is high.</p> <p>0 CPU interrupt disabled 1 CPU interrupt enabled</p>
0 MCGEN	<p>Modulator and Carrier Generator Enable</p> <p>Setting MCGEN will initialize the carrier generator and modulator and will enable all clocks. Once enabled, the carrier generator and modulator will function continuously. When MCGEN is cleared, the current modulator cycle will be allowed to expire before all carrier and modulator clocks are disabled (to save power) and the modulator output is forced low. To prevent spurious operation, the user should initialize all data and control registers before enabling the system.</p> <p>0 Modulator and carrier generator disabled 1 Modulator and carrier generator enabled</p>

39.6.7 CMT Modulator Data Register Mark High (CMT_CMD1)

The contents of this register are transferred to the modulator down counter upon the completion of a modulation period.

Address: CMT_CMD1 is 4006_2000h base + 6h offset = 4006_2006h

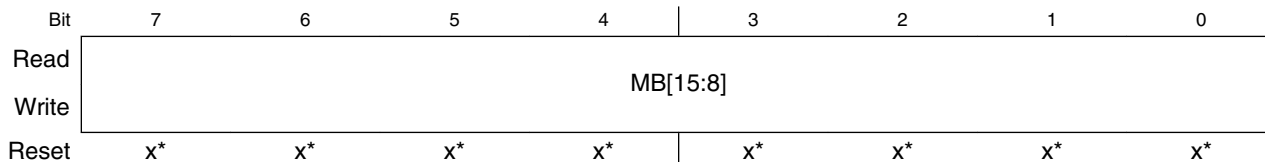

* Notes:

- x = Undefined at reset.

CMT_CMD1 field descriptions

Field	Description
7-0 MB[15:8]	These bits control the upper mark periods of the modulator for all modes.

39.6.8 CMT Modulator Data Register Mark Low (CMT_CMD2)

The contents of this register are transferred to the modulator down counter upon the completion of a modulation period.

Address: CMT_CMD2 is 4006_2000h base + 7h offset = 4006_2007h

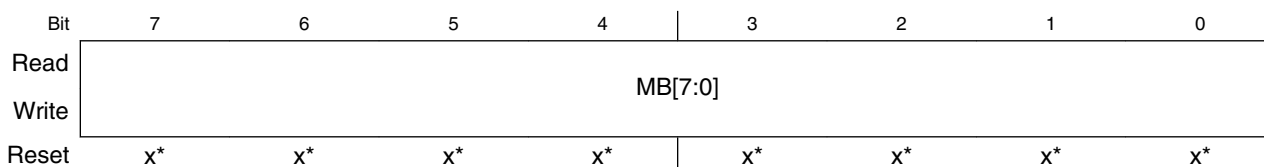

* Notes:

- x = Undefined at reset.

CMT_CMD2 field descriptions

Field	Description
7-0 MB[7:0]	These bits control the lower mark periods of the modulator for all modes.

39.6.9 CMT Modulator Data Register Space High (CMT_CMD3)

The contents of this register are transferred to the space period register upon the completion of a modulation period.

Address: CMT_CMD3 is 4006_2000h base + 8h offset = 4006_2008h

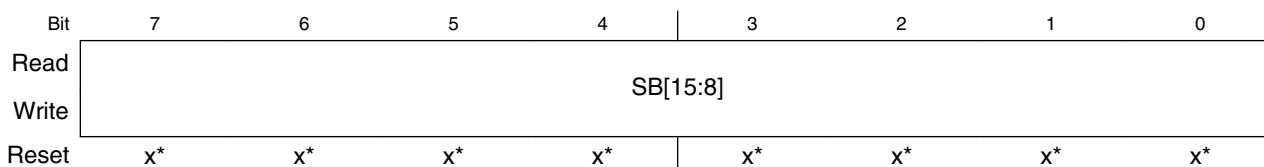

* Notes:

- x = Undefined at reset.

CMT_CMD3 field descriptions

Field	Description
7–0 SB[15:8]	These bits control the upper space periods of the modulator for all modes.

39.6.10 CMT Modulator Data Register Space Low (CMT_CMD4)

The contents of this register are transferred to the space period register upon the completion of a modulation period.

Address: CMT_CMD4 is 4006_2000h base + 9h offset = 4006_2009h

Bit	7	6	5	4	3	2	1	0
Read	SB[7:0]							
Write	SB[7:0]							
Reset	x*	x*	x*	x*	x*	x*	x*	x*

* Notes:

- x = Undefined at reset.

CMT_CMD4 field descriptions

Field	Description
7–0 SB[7:0]	These bits control the lower space periods of the modulator for all modes.

39.6.11 CMT Primary Prescaler Register (CMT_PPS)

This register is used to set the primary prescaler bits (PPSDIV).

Address: CMT_PPS is 4006_2000h base + Ah offset = 4006_200Ah

Bit	7	6	5	4	3	2	1	0
Read	0				PPSDIV			
Write					PPSDIV			
Reset	0	0	0	0	0	0	0	0

CMT_PPS field descriptions

Field	Description
7–4 Reserved	This read-only field is reserved and always has the value zero.
3–0 PPSDIV	Primary Prescaler Divider

Table continues on the next page...

CMT_PPS field descriptions (continued)

Field	Description
	The primary prescaler divides the CMT clock to generate the Intermediate Frequency clock enable to the secondary prescaler.
0000	Bus Clock ÷ 1
0001	Bus Clock ÷ 2
0010	Bus Clock ÷ 3
0011	Bus Clock ÷ 4
0100	Bus Clock ÷ 5
0101	Bus Clock ÷ 6
0110	Bus Clock ÷ 7
0111	Bus Clock ÷ 8
1000	Bus Clock ÷ 9
1001	Bus Clock ÷ 10
1010	Bus Clock ÷ 11
1011	Bus Clock ÷ 12
1100	Bus Clock ÷ 13
1101	Bus Clock ÷ 14
1110	Bus Clock ÷ 15
1111	Bus Clock ÷ 16

39.6.12 CMT Direct Memory Access (CMT_DMA)

This register is used to enable/disable direct memory access (DMA).

Address: CMT_DMA is 4006_2000h base + Bh offset = 4006_200Bh



CMT_DMA field descriptions

Field	Description
7-1 Reserved	This read-only field is reserved and always has the value zero.
0 DMA	DMA Enable This bit enables the DMA protocol.

Table continues on the next page...

CMT_DMA field descriptions (continued)

Field	Description
0	DMA transfer request and done are disabled
1	DMA transfer request and done are enabled

39.7 Functional Description

The CMT module consists primarily of clock divider, carrier generator and modulator.

39.7.1 Clock Divider

The CMT was originally designed to be based on 8 MHz bus clock that could be divided by 1, 2, 4 or 8 times accordingly with the specification. To be compatible with higher bus frequency, the Primary Prescaler (PPS) was developed to receive a higher frequency and generate a clock enable signal called Intermediate Frequency (IF). This IF should be approximately equal to 8 MHz and will work as a clock enable to the Secondary Prescaler. The following figure shows the clock divider block diagram.

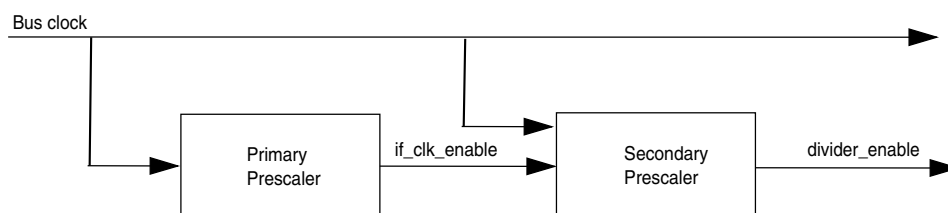

Figure 39-14. Clock Divider Block Diagram

For compatibility with previous versions of CMT, when bus clock = 8 MHz, the PPS should be configured to zero. The PPS counter is selected according to the bus clock to generate an intermediate frequency approximately equal to 8 MHz.

39.7.2 Carrier Generator

The carrier generator resolution is 125 ns when operating with an 8 MHz intermediate frequency signal and the Secondary Prescaler is set to divide by 1 (MSC[CMTDIV] = 00). The carrier generator can generate signals with periods between 250 ns (4 MHz) and 127.5 μ s (7.84 kHz) in steps of 125 ns. The following table shows the relationship between the clock divide bits and the carrier generator resolution, minimum carrier generator period, and minimum modulator period.

Table 39-17. Clock Divider

Bus Clock (MHz)	MSC[CMTDIV]	Carrier Generator Resolution (μ s)	Min. Carrier Generator Period (μ s)	Min. Modulator Period (μ s)
8	00	0.125	0.25	1.0
8	01	0.25	0.5	2.0
8	10	0.5	1.0	4.0
8	11	1.0	2.0	8.0

The possible duty cycle options depend upon the number of counts required to complete the carrier period. For example, 1.6 MHz signal has a period of 625 ns and will therefore require 5 x 125 ns counts to generate. These counts may be split between high and low times, so the duty cycles available will be 20% (one high, four low), 40% (two high, three low), 60% (three high, two low) and 80% (four high, one low).

For lower frequency signals with larger periods, higher resolution (as a percentage of the total period) duty cycles are possible.

The carrier signal is generated by counting a register-selected number of input clocks (125 ns for an 8 MHz bus) for both the carrier high time and the carrier low time. The period is determined by the total number of clocks counted. The duty cycle is determined by the ratio of high time clocks to total clocks counted. The high and low time values are user programmable and are held in two registers.

An alternate set of high/low count values is held in another set of registers to allow the generation of dual frequency FSK (frequency shift keying) protocols without CPU intervention.

Note

Only non-zero data values are allowed. The carrier generator will not work if any of the count values are equal to zero.

MSC[MCGEN] bit must be set and MSC[BASE] bit must be cleared to enable carrier generator clocks. When MSC[BASE] bit is set, the carrier output to the modulator is held high continuously. Following figure represents the block diagram of the clock generator.

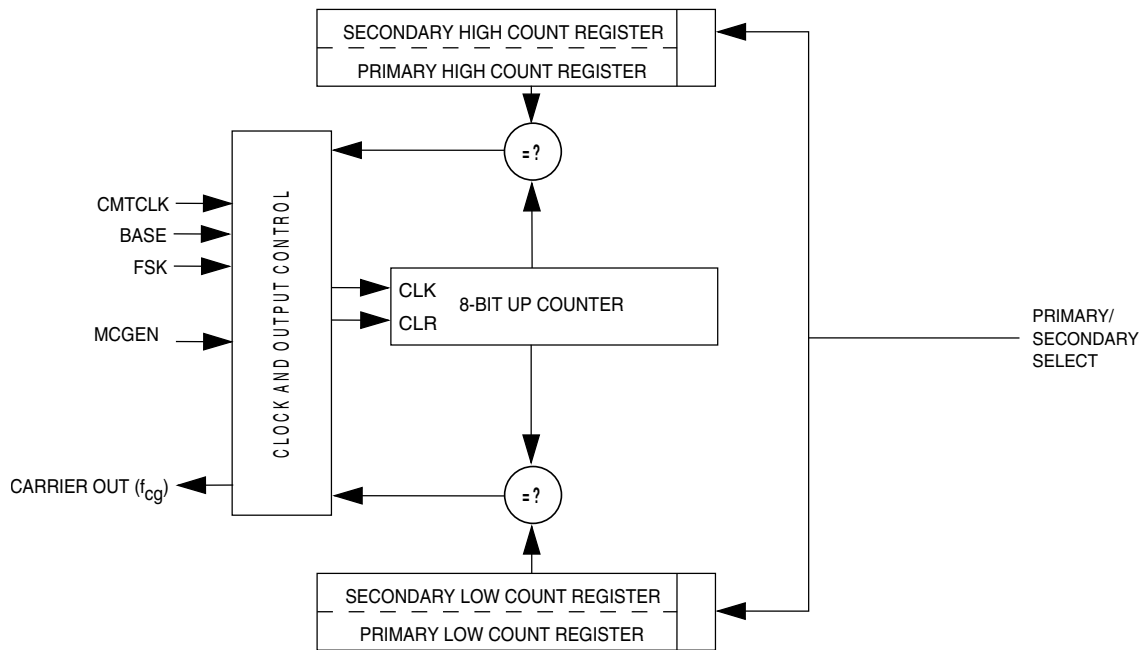

Figure 39-15. Carrier Generator Block Diagram

The high/low time counter is an 8-bit up counter. After each increment, the contents of the counter are compared with the appropriate high or low count value register. When the compare value is reached, the counter is reset to a value of 0x01, and the compare is redirected to the other count value register.

Assuming that the high time count compare register is currently active, a valid compare will cause the carrier output to be driven low. The counter will continue to increment (starting at reset value of 0x01). When the value stored in the selected low count value register is reached, the counter will again be reset and the carrier output will be driven high.

The cycle repeats, automatically generating a periodic signal which is directed to the modulator. The lowest frequency (maximum period) and highest frequency (minimum period) which can be generated are defined as:

$$f_{\max} = f_{\text{CMTCLK}} \div (2 \times 1) \text{ Hz}$$

$$f_{\min} = f_{\text{CMTCLK}} \div (2 \times (2^8 - 1)) \text{ Hz}$$

In the general case, the carrier generator output frequency is:

$$f_{\text{cg}} = f_{\text{CMTCLK}} \div (\text{Highcount} + \text{Lowcount}) \text{ Hz}$$

Where: $0 < \text{Highcount} < 256$ and

$$0 < \text{Lowcount} < 256$$

The duty cycle of the carrier signal is controlled by varying the ratio of high time to low + high time. As the input clock period is fixed, the duty cycle resolution will be proportional to the number of counts required to generate the desired carrier period.

$$\text{DutyCycle} = \frac{\text{Highcount}}{\text{Highcount} + \text{Lowcount}}$$

39.7.3 Modulator

The modulator block controls the state of the infrared out signal (IRO) . The modulator output is gated on to the IRO signal when the modulator/carrier generator is enabled . When the modulator/carrier generator is disabled, the IRO signal is controlled by the state of the IRO latch. OC[CMTPOL] enables the IRO signal to be active high or active low.

In CMT modes, the modulator functions as given below:

- In Time mode, the modulator can gate the carrier onto the modulator output.
- In Baseband mode, the modulator can control the logic level of the modulator output.
- In FSK mode, the modulator can count carrier periods and instruct the carrier generator to alternate between two carrier frequencies whenever a modulation period (mark + space counts) expires.

The modulator provides a simple method to control protocol timing. The modulator has a minimum resolution of 1.0 μ s with an 8 MHz . It can count bus clocks (to provide real-time control) or it can count carrier clocks (for self-clocked protocols).

The modulator includes a 17-bit down counter with underflow detection. The counter is loaded from the 16-bit modulation mark period buffer registers, CMD1 and CMD2. The most significant bit is loaded with a logic zero and serves as a sign bit. When the counter holds a positive value, the modulator gate is open and the carrier signal is driven to the transmitter block.

When the counter underflows, the modulator gate is closed and a 16-bit comparator is enabled which compares the logical complement of the value of the down counter with the contents of the modulation space period register which has been loaded from the registers, CMD3 and CMD4.

When a match is obtained, the cycle repeats by opening the modulator gate, reloading the counter with the contents of CMD1 and CMD2, and reloading the modulation space period register with the contents of CMD3 and CMD4.

The activation of modulation space period is done when the carrier signal is low to prohibit cutting off the high pulse of a carrier signal. If the carrier signal is high, the modulator extends the mark period until the carrier signal become low. To de-assert the space period and assert the mark period, the carrier signal must have gone low to assure that a space period is not erroneously shortened.

Should the contents of the modulation space period register be all zeroes, the match will be immediate and no space period will be generated (for instance, for FSK protocols that require successive bursts of different frequencies).

MSC[MCGEN] must be set to enable the modulator timer.

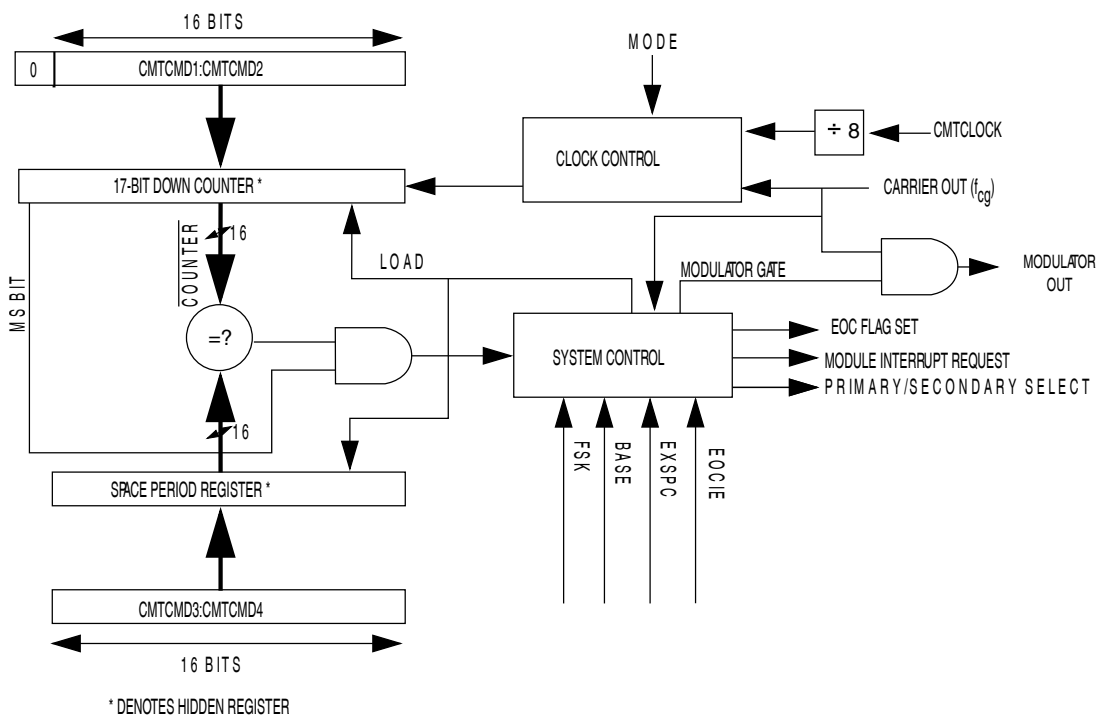

Figure 39-16. Modulator Block Diagram

39.7.3.1 Time Mode

When the modulator operates in time mode (MSC[MCGEN] bit is set, MSC[BASE] and MSC[FSK] bits are cleared), the modulation mark period consists of an integer number of $CMTCLK \div 8$ clock periods. The modulation space period consists of zero or an integer number of $CMTCLK \div 8$ clock periods. With an 8 MHz IF and $MSC[CMTDIV] = 00$, the modulator resolution is 1 μ s and has a maximum mark and space period of about 65.535 ms each. See the following figure for an example of the time mode and baseband mode outputs.

The mark and space time equations for time and baseband mode are:

Functional Description

$$t_{\text{mark}} = (\text{CMD1:CMD2} + 1) \div (f_{\text{CMTCLK}} \div 8)$$

$$t_{\text{space}} = \text{CMD3:CMD4} \div (f_{\text{CMTCLK}} \div 8)$$

where CMD1:CMD2 and CMD3:CMD4 are the decimal values of the concatenated registers.

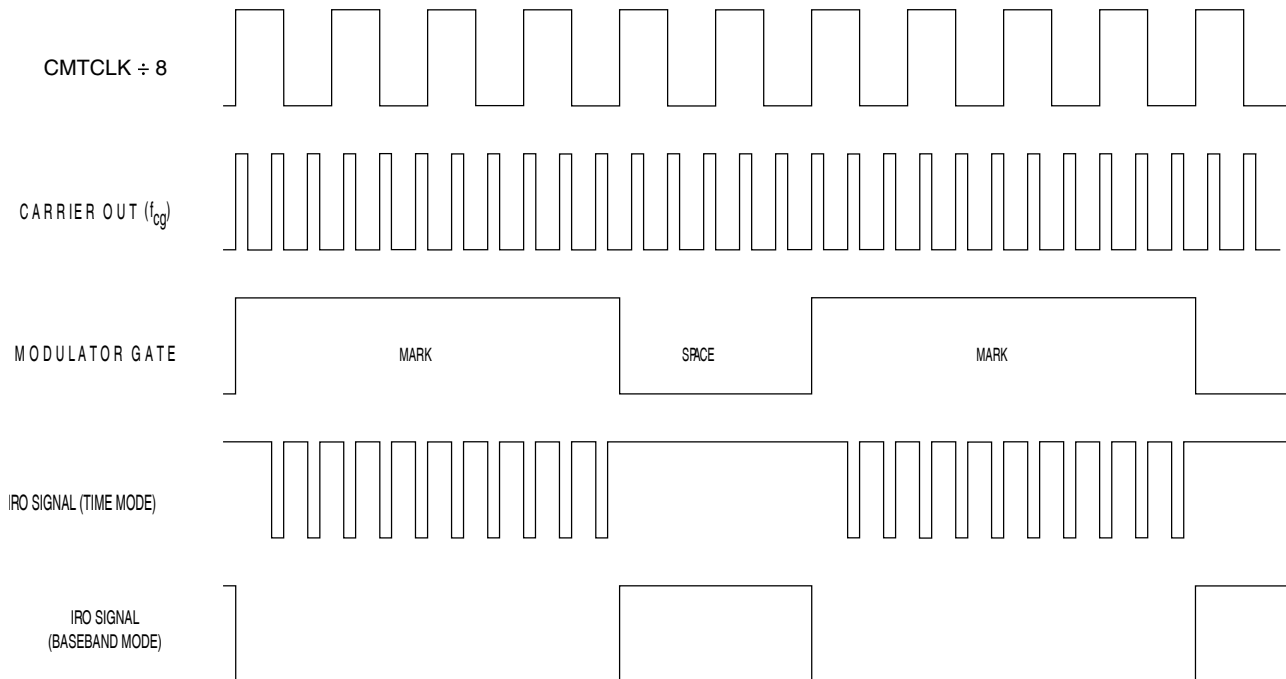

Figure 39-17. Example: CMT Output in Time and Baseband Modes with OC[CMTPOL]=0

39.7.3.2 Baseband Mode

Baseband mode (MSC[MCGEN] and MSC[BASE] bits are set) is a derivative of time mode, where the mark and space period is based on $(\text{CMTCLK} \div 8)$ counts. The mark and space calculations are the same as in time mode. In this mode, the modulator output will be at a logic 1 for the duration of the mark period and at a logic 0 for the duration of a space period. See [Figure 39-17](#) for an example of the output for both baseband and time modes. In the example, the carrier out frequency (f_{cg}) is generated with a high count of 0x01 and a low count of 0x02 that results in a divide of 3 of CMTCLK with a 33% duty cycle. The modulator down counter was loaded with the value 0x0003 and the space period register with 0x0002.

Note

The waveforms in [Figure 39-17](#) and [Figure 39-18](#) are for the purpose of conceptual illustration and are not meant to represent precise timing relationships between the signals shown.

39.7.3.3 FSK Mode

When the modulator operates in FSK mode (MSC[MCGEN] and MSC[FSK] bits are set, and MSC[BASE] bit is cleared), the modulation mark and space periods consist of an integer number of carrier clocks (space period can be zero). When the mark period expires, the space period is transparently started (as in time mode). The carrier generator toggles between primary and secondary data register values whenever the modulator space period expires.

The space period provides an interpulse gap (no carrier). If CMD3:CMD4 = 0x0000, then the modulator and carrier generator will switch between carrier frequencies without a gap or any carrier glitches (zero space).

Using timing data for carrier burst and interpulse gap length calculated by the CPU, FSK mode can automatically generate a phase-coherent, dual-frequency FSK signal with programmable burst and interburst gaps.

The mark and space time equations for FSK mode are:

$$t_{\text{mark}} = (\text{CMD1:CMD2} + 1) \div f_{\text{cg}}$$

$$t_{\text{space}} = \text{CMD3:CMD4} \div f_{\text{cg}}$$

Where f_{cg} is the frequency output from the carrier generator. The example in figure below shows what the IRO signal looks like in FSK mode with the following values: CMD1:CMD2 = 0x0003, CMD3:CMD4 = 0x0002, primary carrier high count = 0x01, primary carrier low count = 0x02, secondary carrier high count = 0x03, and secondary carrier low count = 0x01.

functional Description

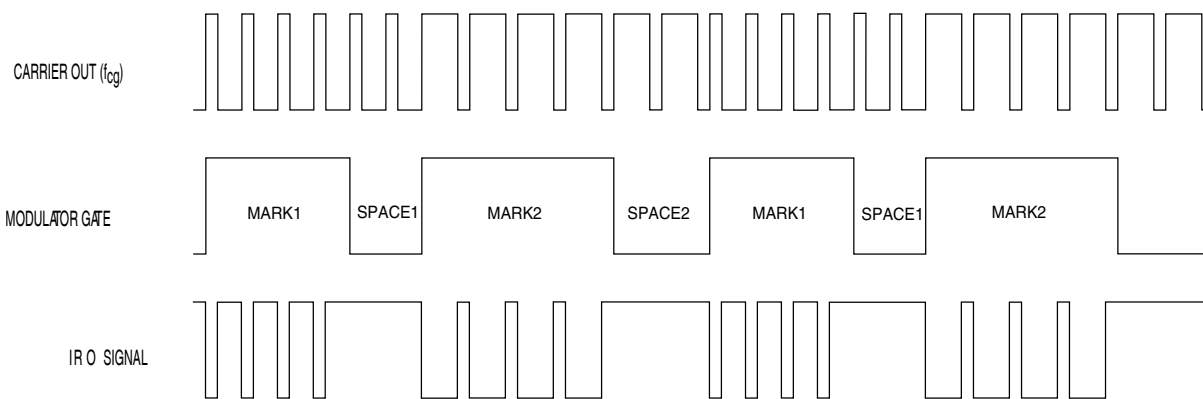

Figure 39-18. Example: CMT Output in FSK Mode

39.7.4 Extended Space Operation

In either time, baseband or FSK mode, the space period can be made longer than the maximum possible value of the space period register . Setting MSC[EXSPC] bit will force the modulator to treat the next modulation period (beginning with the next load of the counter and space period register) as a space period equal in length to the mark and space counts combined . Subsequent modulation periods will consist entirely of these extended space periods with no mark periods . Clearing MSC[EXSPC] will return the modulator to standard operation at the beginning of the next modulation period .

39.7.4.1 EXSPC Operation in Time Mode

To calculate the length of an extended space in time or baseband mode, add the mark and space times and multiply by the number of modulation periods when MSC[EXSPC] is set.

$$t_{\text{exspace}} = (t_{\text{mark}} + t_{\text{space}}) \times (\text{number of modulation periods})$$

For an example of extended space operation, see the following figure.

Note

The extended space enable feature can be used to emulate a zero mark event.

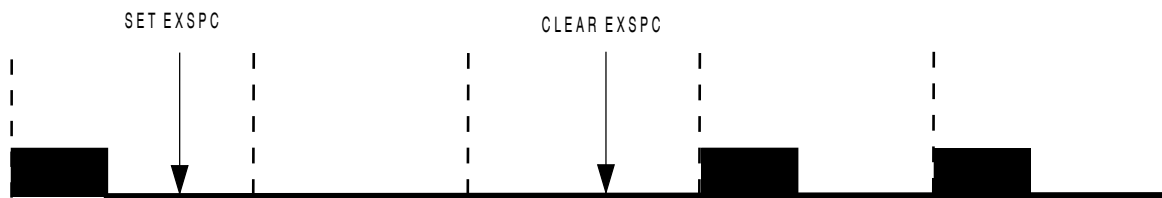
Figure 39-19. Extended Space Operation

39.7.4.2 EXSPC Operation in FSK Mode

In FSK mode, the modulator continues to count carrier out clocks, alternating between the primary and secondary registers at the end of each modulation period.

To calculate the length of an extended space in FSK mode, one needs to know whether MSC[EXSPC] bit was set on a primary or secondary modulation period, as well as the total number of both primary and secondary modulation periods completed while MSC[EXSPC] bit is high. A status bit for the current modulation is not accessible to the CPU. If necessary, software should maintain tracking of the current modulation cycle (primary or secondary). The extended space period ends at the completion of the space period time of the modulation period during which MSC[EXSPC] bit is cleared.

If MSC[EXSPC] bit was set during a primary modulation cycle, use the equation:

$$t_{\text{exspace}} = (t_{\text{space}})_p + (t_{\text{mark}} + t_{\text{space}})_s + (t_{\text{mark}} + t_{\text{space}})_p + \dots$$

Where the subscripts p and s refer to mark and space times for the primary and secondary modulation cycles.

If MSC[EXSPC] bit was set during a secondary modulation cycle, use the equation:

$$t_{\text{exspace}} = (t_{\text{space}})_s + (t_{\text{mark}} + t_{\text{space}})_p + (t_{\text{mark}} + t_{\text{space}})_s + \dots$$

39.8 CMT Interrupts and DMA

The CMT generates an Interrupt request or a DMA transfer request according to MSC[EOCF], MSC[EOCF], DMA[DMA] bits.

Table 39-18. DMA Transfer Request x CMT Interrupt Request

MSC[EOCF]	DMA[DMA]	MSC[EOCF]	DMA transfer request	CMT interrupt request
0	X	X	0	0
1	X	0	0	0
1	0	1	0	1
1	1	1	1	0

MSC[EOCF] is set when:

- The modulator is not currently active and MSC[MCGEN] bit is set to begin the initial CMT transmission
- At the end of each modulation cycle (when the counter is reloaded from CMD1:CMD2) while MSC[MCGEN] bit is set

In the case where MSC[MCGEN] bit is cleared and then set before the end of the modulation cycle, MSC[EOCF] bit will not be set when MSC[MCGEN] is set, but will become set at the end of the current modulation cycle.

When MSC[MCGEN] becomes disabled, the CMT module does not set the EOC flag at the end of the last modulation cycle.

If MSC[EOCIE] bit is high when MSC[EOCF] bit is set, the CMT module will generate an interrupt request or a DMA transfer request.

MSC[EOCF] bit must be cleared to prevent from being generated another event (interrupt or DMA request) after exiting the service routine. See following table.

Table 39-19. How to clear MSC[EOCF] bit

DMA[DMA]	MSC[EOCIE]	Description
0	X	MSC[EOCF] bit is cleared by reading the CMT modulator status and control register MSC followed by an access of CMD2 or CMD4.
1	X	MSC[EOCF] bit is cleared by the CMT DMA transfer done.

The EOC interrupt is coincident with loading the down-counter with the contents of CMD1:CMD2 and loading the space period register with the contents of CMD3:CMD4. The EOC interrupt provides a means for the user to reload new mark/space values into the modulator data registers. Modulator data register updates will take effect at the end of the current modulation cycle. Note that the down-counter and space period register are updated at the end of every modulation cycle, irrespective of interrupt handling and the state of the EOCF flag.

Chapter 40

Real Time Clock (RTC)

40.1 Introduction

NOTE

For the chip-specific implementation details of this module's instances see the chip configuration chapter.

40.1.1 Features

The RTC module features include:

- Independent power supply, POR and 32 kHz crystal oscillator
- 32-bit seconds counter with roll-over protection and 32-bit alarm
- 16-bit prescaler with compensation that can correct errors between 0.12 ppm and 3906 ppm
- Register write protection
 - Lock register requires VBAT POR or software reset to enable write access
 - Access control registers require system reset to enable read and/or write access
- 1 Hz square wave output

40.1.2 Modes of operation

The RTC operates in one of two modes of operation, chip power-up and chip power-down.

During chip power-down, RTC is powered from the backup power supply (VBAT) and is electrically isolated from the rest of the chip but continues to increment the time counter (if enabled) and retain the state of the RTC registers. The RTC registers are not accessible.

During chip power-up, RTC remains powered from the backup power supply (VBAT). All RTC registers are accessible by software and all functions are operational. If enabled, the 32.768 kHz clock can be supplied to the rest of the chip.

40.1.3 RTC signal descriptions

Table 40-1. RTC signal descriptions

Signal	Description	I/O
EXTAL32	32.768 kHz oscillator input	I
XTAL32	32.768 kHz oscillator output	O
RTC_CLKOUT	1Hz square-wave output	O
RTC_WAKEUP	Wakeup for external device	O

40.1.3.1 RTC clock output

The clock to the seconds counter is available on the RTC_CLKOUT signal. It is a 1Hz square wave output.

40.1.3.2 RTC wakeup pin

The RTC wakeup pin is an open drain, active low, output that allows the RTC to wakeup the chip via an external component. The wakeup pin asserts when the wakeup pin enable is set, the RTC interrupt is asserted and the chip is powered down. The wakeup pin does not assert from the RTC seconds interrupt.

The wakeup pin is optional and may not be implemented on all devices.

40.2 Register definition

All registers must be accessed using 32-bit writes and all register accesses incur three wait states.

Write accesses to any register by non-supervisor mode software, when the supervisor access bit in the control register is clear, will terminate with a bus error.

Read accesses by non-supervisor mode software complete as normal.

Writing to a register protected by the write access register or lock register does not generate a bus error, but the write will not complete.

Reading a register protected by the read access register does not generate a bus error, but the register will read zero.

RTC memory map

Absolute address (hex)	Register name	Width (in bits)	Access	Reset value	Section/page
4003_D000	RTC Time Seconds Register (RTC_TSR)	32	R/W	0000_0000h	40.2.1/ 979
4003_D004	RTC Time Prescaler Register (RTC_TPR)	32	R/W	0000_0000h	40.2.2/ 980
4003_D008	RTC Time Alarm Register (RTC_TAR)	32	R/W	0000_0000h	40.2.3/ 980
4003_D00C	RTC Time Compensation Register (RTC_TCR)	32	R/W	0000_0000h	40.2.4/ 981
4003_D010	RTC Control Register (RTC_CR)	32	R/W	0000_0000h	40.2.5/ 982
4003_D014	RTC Status Register (RTC_SR)	32	R/W	0000_0001h	40.2.6/ 984
4003_D018	RTC Lock Register (RTC_LR)	32	R/W	0000_00FFh	40.2.7/ 985
4003_D01C	RTC Interrupt Enable Register (RTC_IER)	32	R/W	0000_0007h	40.2.8/ 986
4003_D800	RTC Write Access Register (RTC_WAR)	32	R/W	0000_00FFh	40.2.9/ 987
4003_D804	RTC Read Access Register (RTC_RAR)	32	R/W	0000_00FFh	40.2.10/ 988

40.2.1 RTC Time Seconds Register (RTC_TSR)

Address: RTC_TSR is 4003_D000h base + 0h offset = 4003_D000h

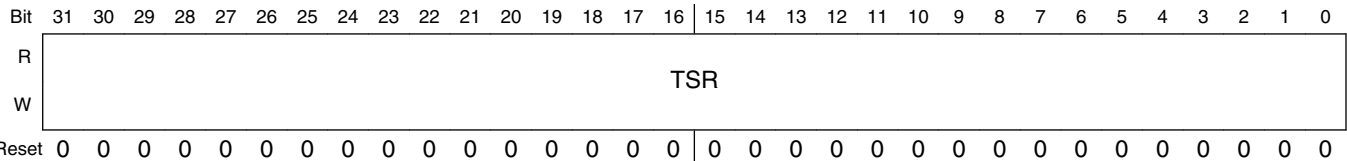

RTC_TSR field descriptions

Field	Description
31–0 TSR	Time Seconds Register When the time counter is enabled, the TSR is read only and increments once a second provided SR[TOF] or SR[TIF] are not set. The time counter will read as zero when SR[TOF] or SR[TIF] are set. When the time counter is disabled, the TSR can be read or written. Writing to the TSR when the time counter is disabled will clear the SR[TOF] and/or the SR[TIF]. Writing to the TSR register with zero is supported, but not recommended since TSR will read as zero when SR[TIF] or SR[TOF] are set (indicating the time is invalid).

40.2.2 RTC Time Prescaler Register (RTC_TPR)

Address: RTC_TPR is 4003_D000h base + 4h offset = 4003_D004h

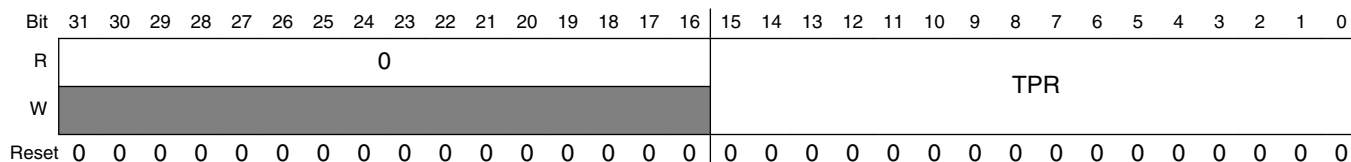

RTC_TPR field descriptions

Field	Description
31–16 Reserved	This read-only field is reserved and always has the value zero.
15–0 TPR	Time Prescaler Register When the time counter is enabled, the TPR is read only and increments every 32.768 kHz clock cycle. The time counter will read as zero when SR[TOF] or SR[TIF] are set. When the time counter is disabled, the TPR can be read or written. The TSR[TSR] increments when bit 14 of the TPR transitions from a logic one to a logic zero.

40.2.3 RTC Time Alarm Register (RTC_TAR)

Address: RTC_TAR is 4003_D000h base + 8h offset = 4003_D008h

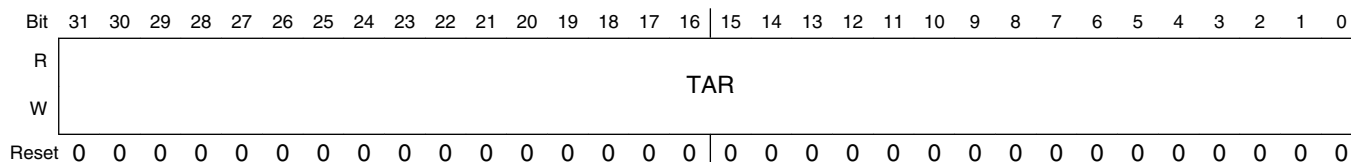

RTC_TAR field descriptions

Field	Description
31–0 TAR	Time Alarm Register

RTC_TAR field descriptions (continued)

Field	Description
	When the time counter is enabled, the SR[TAF] is set whenever the TAR[TAR] equals the TSR[TSR] and the TSR[TSR] increments. Writing to the TAR clears the SR[TAF].

40.2.4 RTC Time Compensation Register (RTC_TCR)

Address: RTC_TCR is 4003_D000h base + Ch offset = 4003_D00Ch

Bit	31	30	29	28	27	26	25	24	23	22	21	20	19	18	17	16	15	14	13	12	11	10	9	8	7	6	5	4	3	2	1	0	
R	CIC								TCV								CIR				TCR												
W	█								█																								
Reset	0	0	0	0	0	0	0	0	0	0	0	0	0	0	0	0	0	0	0	0	0	0	0	0	0	0	0	0	0	0	0	0	0

RTC_TCR field descriptions

Field	Description
31–24 CIC	<p>Compensation Interval Counter</p> <p>Current value of the compensation interval counter. If the compensation interval counter equals zero then it is loaded with the contents of the CIR. If the CIC does not equal zero then it is decremented once a second.</p>
23–16 TCV	<p>Time Compensation Value</p> <p>Current value used by the compensation logic for the present second interval. Updated once a second if the CIC equals 0 with the contents of the TCR field. If the CIC does not equal zero then it is loaded with zero (compensation is not enabled for that second increment).</p>
15–8 CIR	<p>Compensation Interval Register</p> <p>Configures the compensation interval in seconds from 1 to 256 to control how frequently the TCR should adjust the number of 32.768 kHz cycles in each second. The value written should be one less than the number of seconds (for example, write zero to configure for a compensation interval of one second). This register is double buffered and writes do not take affect until the end of the current compensation interval.</p>
7–0 TCR	<p>Time Compensation Register</p> <p>Configures the number of 32.768 kHz clock cycles in each second. This register is double buffered and writes do not take affect until the end of the current compensation interval.</p> <p>80h Time prescaler register overflows every 32896 clock cycles. FFh Time prescaler register overflows every 32769 clock cycles. 00h Time prescaler register overflows every 32768 clock cycles. 01h Time prescaler register overflows every 32767 clock cycles. 7Fh Time prescaler register overflows every 32641 clock cycles.</p>

40.2.5 RTC Control Register (RTC_CR)

Address: RTC_CR is 4003_D000h base + 10h offset = 4003_D010h

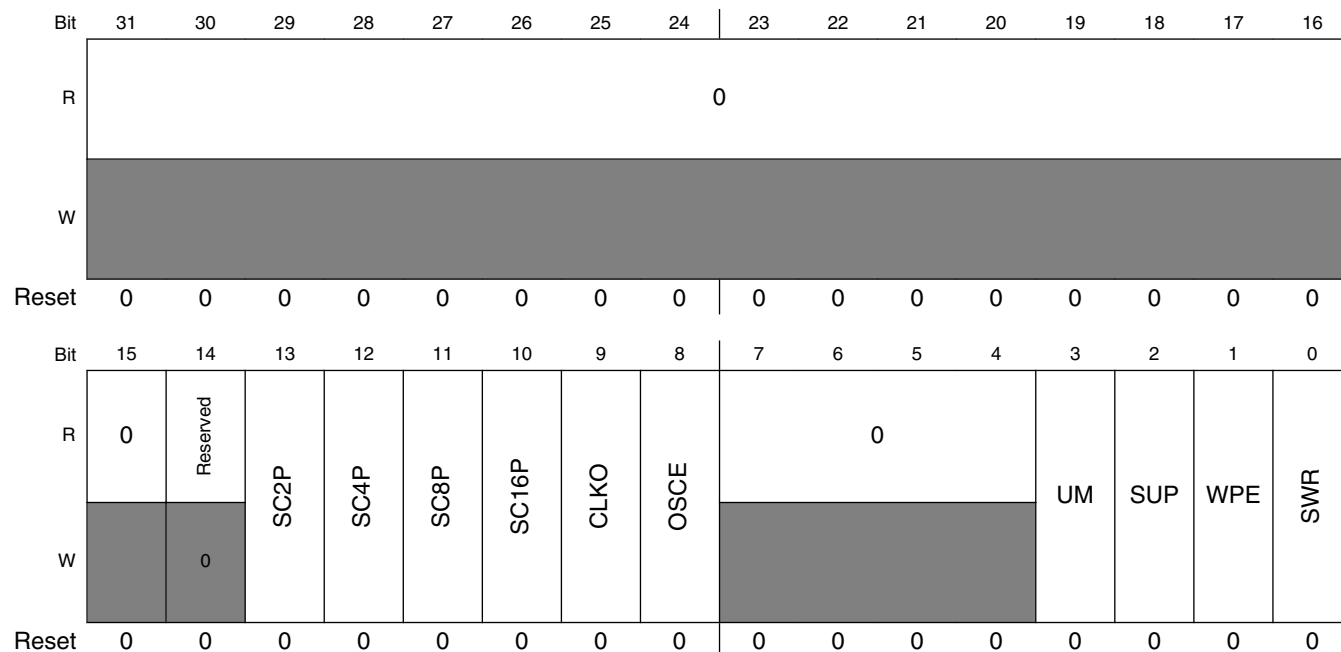

RTC_CR field descriptions

Field	Description
31–15 Reserved	This read-only field is reserved and always has the value zero.
14 Reserved	This field is reserved. It must always be written to 0.
13 SC2P	Oscillator 2pF load configure 0 Disable the load. 1 Enable the additional load.
12 SC4P	Oscillator 4pF load configure 0 Disable the load. 1 Enable the additional load.
11 SC8P	Oscillator 8pF load configure 0 Disable the load. 1 Enable the additional load.
10 SC16P	Oscillator 16pF load configure 0 Disable the load. 1 Enable the additional load.

Table continues on the next page...

RTC_CR field descriptions (continued)

Field	Description
9 CLKO	Clock Output 0 The 32kHz clock is output to other peripherals 1 The 32kHz clock is not output to other peripherals
8 OSCE	Oscillator Enable 0 32.768 kHz oscillator is disabled. 1 32.768 kHz oscillator is enabled. After setting this bit, wait the oscillator startup time before enabling the time counter to allow the 32.768 kHz clock time to stabilize.
7–4 Reserved	This read-only field is reserved and always has the value zero.
3 UM	Update Mode Allows the SR[TCE] to be written even when the Status Register is locked. When set, the SR[TCE] can always be written if the SR[TIF] or SR[TOF] are set or if the SR[TCE] is clear. 0 Registers cannot be written when locked. 1 Registers can be written when locked under limited conditions.
2 SUP	Supervisor Access 0 Non-supervisor mode write accesses are not supported and generate a bus error. 1 Non-supervisor mode write accesses are supported.
1 WPE	Wakeup Pin Enable The wakeup pin is optional and not available on all devices. 0 Wakeup pin is disabled. 1 Wakeup pin is enabled and wakeup pin asserts if the RTC interrupt asserts and the chip is powered down.
0 SWR	Software Reset 0 No effect 1 Resets all RTC registers except for the SWR bit and the RTC_WAR and RTC_RAR registers. The SWR bit is cleared after VBAT POR and by software explicitly clearing it.

40.2.6 RTC Status Register (RTC_SR)

Address: RTC_SR is 4003_D000h base + 14h offset = 4003_D014h

Bit	31	30	29	28	27	26	25	24		23	22	21	20	19	18	17	16
R	0																
W	[Shaded]																
Reset	0	0	0	0	0	0	0	0		0	0	0	0	0	0	0	0
Bit	15	14	13	12	11	10	9	8		7	6	5	4	3	2	1	0
R	0								TCE	0	TAF	TOF	TIF				
W	[Shaded]								[Shaded]	[Shaded]	[Shaded]	[Shaded]					
Reset	0	0	0	0	0	0	0	0		0	0	0	0	0	0	0	1

RTC_SR field descriptions

Field	Description
31–5 Reserved	This read-only field is reserved and always has the value zero.
4 TCE	<p>Time Counter Enable</p> <p>When time counter is disabled the TSR register and TPR register are writeable, but do not increment. When time counter is enabled the TSR register and TPR register are not writeable, but increment.</p> <p>0 Time counter is disabled. 1 Time counter is enabled.</p>
3 Reserved	This read-only field is reserved and always has the value zero.
2 TAF	<p>Time Alarm Flag</p> <p>Time alarm flag is set when the TAR[TAR] equals the TSR[TSR] and the TSR[TSR] increments. This bit is cleared by writing the TAR register.</p> <p>0 Time alarm has not occurred. 1 Time alarm has occurred.</p>
1 TOF	<p>Time Overflow Flag</p> <p>Time overflow flag is set when the time counter is enabled and overflows. The TSR and TPR do not increment and read as zero when this bit is set. This bit is cleared by writing the TSR register when the time counter is disabled.</p> <p>0 Time overflow has not occurred. 1 Time overflow has occurred and time counter is read as zero.</p>
0 TIF	<p>Time Invalid Flag</p> <p>The time invalid flag is set on VBAT POR or software reset. The TSR and TPR do not increment and read as zero when this bit is set. This bit is cleared by writing the TSR register when the time counter is disabled.</p> <p>0 Time is valid. 1 Time is invalid and time counter is read as zero.</p>

40.2.7 RTC Lock Register (RTC_LR)

Address: RTC_LR is 4003_D000h base + 18h offset = 4003_D018h

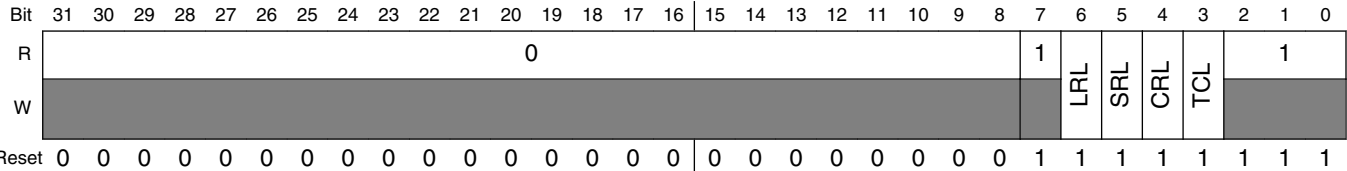

RTC_LR field descriptions

Field	Description
31–8 Reserved	This read-only field is reserved and always has the value zero.
7 Reserved	This read-only field is reserved and always has the value one.
6 LRL	Lock Register Lock Once cleared, this bit can only be set by VBAT POR or software reset. 0 Lock register is locked and writes are ignored. 1 Lock register is not locked and writes complete as normal.
5 SRL	Status Register Lock Once cleared, this bit can only be set by VBAT POR or software reset. 0 Status register is locked and writes are ignored. 1 Status register is not locked and writes complete as normal.
4 CRL	Control Register Lock Once cleared, this bit can only be set by VBAT POR. 0 Control register is locked and writes are ignored. 1 Control register is not locked and writes complete as normal.
3 TCL	Time Compensation Lock Once cleared, this bit can only be set by VBAT POR or software reset. 0 Time compensation register is locked and writes are ignored. 1 Time compensation register is not locked and writes complete as normal.
2–0 Reserved	This read-only field is reserved and always has the value one.

40.2.8 RTC Interrupt Enable Register (RTC_IER)

Address: RTC_IER is 4003_D000h base + 1Ch offset = 4003_D01Ch

Bit	31	30	29	28	27	26	25	24	23	22	21	20	19	18	17	16	
R	0																
W	[Shaded]																
Reset	0	0	0	0	0	0	0	0	0	0	0	0	0	0	0	0	
Bit	15	14	13	12	11	10	9	8	7	6	5	4	3	2	1	0	
R	0								Reserved			Reserved	Reserved	TAIE	TOIE	TIIE	
W	[Shaded]								Reserved			Reserved	Reserved	TAIE	TOIE	TIIE	
Reset	0	0	0	0	0	0	0	0	0	0	0	0	0	0	1	1	1

RTC_IER field descriptions

Field	Description
31–8 Reserved	This read-only field is reserved and always has the value zero.
7–5 Reserved	This field is reserved.
4 Reserved	This field is reserved.
3 Reserved	This field is reserved.
2 TAIE	Time Alarm Interrupt Enable 0 Time alarm flag does not generate an interrupt. 1 Time alarm flag does generate an interrupt.
1 TOIE	Time Overflow Interrupt Enable 0 Time overflow flag does not generate an interrupt. 1 Time overflow flag does generate an interrupt.
0 TIIE	Time Invalid Interrupt Enable 0 Time invalid flag does not generate an interrupt. 1 Time invalid flag does generate an interrupt.

40.2.9 RTC Write Access Register (RTC_WAR)

Address: RTC_WAR is 4003_D000h base + 800h offset = 4003_D800h

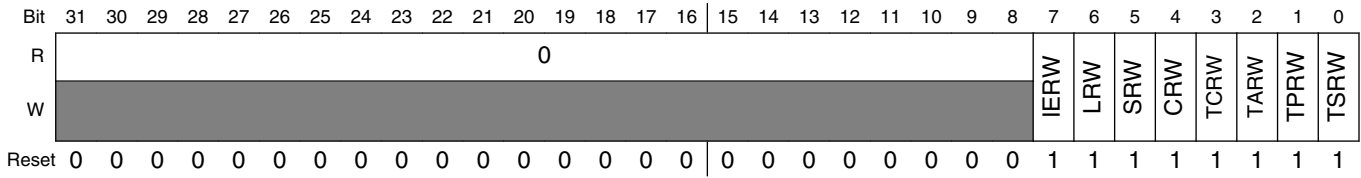

RTC_WAR field descriptions

Field	Description
31–8 Reserved	This read-only field is reserved and always has the value zero.
7 IERW	Interrupt Enable Register Write Once cleared, this bit is only set by system reset. It is not affected by VBAT POR or software reset. 0 Writes to the interrupt enable register are ignored. 1 Writes to the interrupt enable register complete as normal.
6 LRW	Lock Register Write Once cleared, this bit is only set by system reset. It is not affected by VBAT POR or software reset. 0 Writes to the lock register are ignored. 1 Writes to the lock register complete as normal.
5 SRW	Status Register Write Once cleared, this bit is only set by system reset. It is not affected by VBAT POR or software reset. 0 Writes to the status register are ignored. 1 Writes to the status register complete as normal.
4 CRW	Control Register Write Once cleared, this bit is only set by system reset. It is not affected by VBAT POR or software reset. 0 Writes to the control register are ignored. 1 Writes to the control register complete as normal.
3 TCRW	Time Compensation Register Write Once cleared, this bit is only set by system reset. It is not affected by VBAT POR or software reset. 0 Writes to the time compensation register are ignored. 1 Writes to the time compensation register complete as normal.
2 TARW	Time Alarm Register Write Once cleared, this bit is only set by system reset. It is not affected by VBAT POR or software reset. 0 Writes to the time alarm register are ignored. 1 Writes to the time alarm register complete as normal.

Table continues on the next page...

RTC_WAR field descriptions (continued)

Field	Description
1 TPRW	Time Prescaler Register Write Once cleared, this bit is only set by system reset. It is not affected by VBAT POR or software reset. 0 Writes to the time prescaler register are ignored. 1 Writes to the time prescaler register complete as normal.
0 TSRW	Time Seconds Register Write Once cleared, this bit is only set by system reset. It is not affected by VBAT POR or software reset. 0 Writes to the time seconds register are ignored. 1 Writes to the time seconds register complete as normal.

40.2.10 RTC Read Access Register (RTC_RAR)

Address: RTC_RAR is 4003_D000h base + 804h offset = 4003_D804h

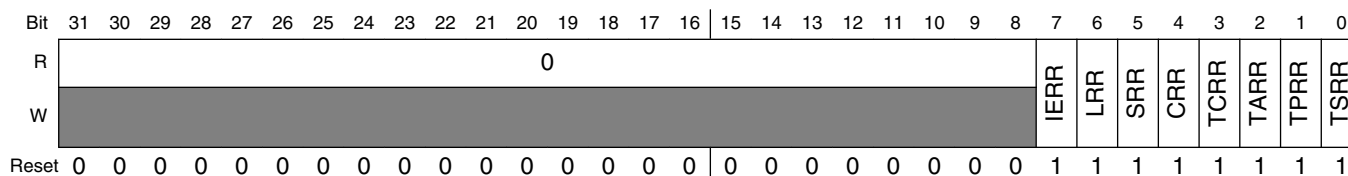

RTC_RAR field descriptions

Field	Description
31–8 Reserved	This read-only field is reserved and always has the value zero.
7 IERR	Interrupt Enable Register Read Once cleared, this bit is only set by system reset. It is not affected by VBAT POR or software reset. 0 Reads to the interrupt enable register are ignored. 1 Reads to the interrupt enable register complete as normal.
6 LRR	Lock Register Read Once cleared, this bit is only set by system reset. It is not affected by VBAT POR or software reset. 0 Reads to the lock register are ignored. 1 Reads to the lock register complete as normal.
5 SRR	Status Register Read Once cleared, this bit is only set by system reset. It is not affected by VBAT POR or software reset. 0 Reads to the status register are ignored. 1 Reads to the status register complete as normal.

Table continues on the next page...

RTC_RAR field descriptions (continued)

Field	Description
4 CRR	Control Register Read Once cleared, this bit is only set by system reset. It is not affected by VBAT POR or software reset. 0 Reads to the control register are ignored. 1 Reads to the control register complete as normal.
3 TCRR	Time Compensation Register Read Once cleared, this bit is only set by system reset. It is not affected by VBAT POR or software reset 0 Reads to the time compensation register are ignored. 1 Reads to the time compensation register complete as normal.
2 TARR	Time Alarm Register Read Once cleared, this bit is only set by system reset. It is not affected by VBAT POR or software reset. 0 Reads to the time alarm register are ignored. 1 Reads to the time alarm register complete as normal.
1 TPRR	Time Prescaler Register Read Once cleared, this bit is only set by system reset. It is not affected by VBAT POR or software reset. 0 Reads to the time prescaler register are ignored. 1 Reads to the time prescaler register complete as normal.
0 TSRR	Time Seconds Register Read Once cleared, this bit is only set by system reset. It is not affected by VBAT POR or software reset. 0 Reads to the time seconds register are ignored. 1 Reads to the time seconds register complete as normal.

40.3 Functional description

40.3.1 Power, clocking and reset

The RTC is an always powered block that is powered by the battery power supply (VBAT). The battery power supply ensures that the RTC registers retain their state during chip power-down and that the RTC time counter remains operational.

The time counter within the RTC is clocked by a 32.768 kHz clock and can supply this clock to other peripherals. The 32.768 kHz clock can only be sourced from an external crystal using the oscillator that is part of the RTC module.

The RTC includes its own analog POR block, which generates a power-on-reset signal whenever the RTC module is powered up and initializes all RTC registers to their default state. A software reset bit can also initialize all RTC registers. The RTC also monitors the chip power supply and electrically isolates itself when the rest of the chip is powered down.

Any attempt to access an RTC register (except the access control registers) when VBAT is powered down, when the RTC is electrically isolated, or when VBAT POR is asserted, will result in a bus error.

40.3.1.1 Oscillator control

The 32.768 kHz crystal oscillator is disabled at VBAT POR and must be enabled by software. After enabling the crystal oscillator, wait the oscillator startup time before setting the SR[TCE] bit or using the oscillator clock external to the RTC.

The crystal oscillator includes tunable capacitors that can be configured by software. Do not change the capacitance unless the oscillator is disabled.

40.3.1.2 Software reset

Writing one to the CR[SWR] forces the equivalent of a VBAT POR to the rest of the RTC module. The CR[SWR] is not affected by the software reset and must be cleared by software. The access control registers are not affected by either VBAT POR or the software reset; they are reset by the chip reset.

40.3.1.3 Supervisor access

When the supervisor access control bit is clear, only supervisor mode software can write to the RTC registers, non-supervisor mode software will generate a bus error. Both supervisor and non-supervisor mode software can always read the RTC registers.

40.3.2 Time counter

The time counter consists of a 32-bit seconds counter that increments once every second and a 16-bit prescaler register that increments once every 32.768 kHz clock cycle.

The time seconds register and time prescaler register can only be written when the SR[TCE] bit is clear. Always write to the prescaler register before writing to the seconds register, since the seconds register increments on the falling edge of bit 14 of the prescaler register.

The time prescaler register increments provided the SR[TCE] bit is set, the SR[TIF] is clear, the SR[TOF] is clear and the 32.768 kHz clock source is present. After enabling the oscillator, wait the oscillator startup time before setting the SR[TCE] bit to allow time for the oscillator clock output to stabilize.

If the time seconds register overflows then the SR[TOF] will set and the time prescaler register will stop incrementing. Clear the SR[TOF] by initializing the time seconds register. The time seconds register and time prescaler register read as zero whenever the SR[TOF] is set.

The SR[TIF] is set on VBAT POR and software reset and is cleared by initializing the time seconds register. The time seconds register and time prescaler register read as zero whenever the SR[TIF] is set.

40.3.3 Compensation

The compensation logic provides an accurate and wide compensation range and can correct errors as high as 3906 ppm and as low as 0.12 ppm. Note that the compensation factor must be calculated externally to the RTC and supplied by software to the compensation register. The RTC itself does not calculate the amount of compensation that is required, although the 1 Hz clock is output to an external pin in support of external calibration logic.

Crystal compensation can be supported by using firmware and crystal characteristics to determine the compensation amount. Temperature compensation can be supported by firmware that periodically measures the external temperature (via ADC) and updates the compensation register based on a look-up table that specifies the change in crystal frequency over temperature.

The compensation logic alters the number of 32.768 kHz clock cycles it takes for the prescaler register to overflow and increment the time seconds counter. The time compensation value is used to adjust the number of clock cycles between -127 and +128. Cycles are added or subtracted from the prescaler register when the prescaler register equals 0x3FFF and then increments. The compensation interval is used to adjust the frequency at which the time compensation value is used (from once a second to once every 256 seconds).

Updates to the time compensation register will not take effect until the next time the time seconds register increments and provided the previous compensation interval has expired. When the compensation interval is set to other than once a second then the compensation is applied in the first second interval and the remaining second intervals receive no compensation.

Compensation is disabled by configuring the time compensation register to zero.

40.3.4 Time alarm

The time alarm register, SR[TAF] and IER[TAIE] allow the RTC to generate an interrupt at a predefined time. The 32-bit time alarm register is compared with the 32-bit time seconds register each time it increments. The SR[TAF] will set when the time alarm register equals the time seconds register and the time seconds register increments.

The time alarm flag is cleared by writing the time alarm register. This will usually be the next alarm value, although writing a value that is less than the time seconds register (such as zero) will prevent the time alarm flag from setting again. The time alarm flag cannot otherwise be disabled, although the interrupt it generates is enabled or disabled by IER[TAIE].

40.3.5 Update mode

The update mode bit (CR[UM]) in the control register configures software write access to the time counter enable (SR[TCE]) bit. When CR[UM] is clear, SR[TCE] can only be written when the LR[SRL] bit is set. When CR[UM] is set, the SR[TCE] can also be written when SR[TCE] is clear or when SR[TIF] or SR[TOF] are set. This allows the time seconds and prescaler registers to be initialized whenever time is invalidated, while preventing the time seconds and prescaler registers from being changed on the fly. When LR[SRL] is set, the CR[UM] bit has no effect on SR[TCE].

40.3.6 Register lock

The lock register can be used to block write accesses to certain registers until the next VBAT POR or software reset. Locking the control register will disable the software reset. Locking the lock register will block future updates to the lock register.

Write accesses to a locked register are ignored and do not generate a bus error.

40.3.7 Access control

The read access and write access registers are implemented in the chip power domain and reset on the chip reset (they are not affected by the VBAT POR or the software reset). They are used to block read or write accesses to each register until the next chip system reset. When accesses are blocked the bus access is not seen in the VBAT power supply and does not generate a bus error.

40.3.8 Interrupt

The RTC Interrupt is asserted whenever a status flag and the corresponding interrupt enable bit are both set. It is always asserted on VBAT POR, software reset and when the VBAT power supply is powered down. The RTC interrupt is enabled at the chip level by enabling the chip-specific RTC clock gate control bit. The RTC Interrupt can be used to wakeup the chip from any low power mode.

The optional RTC seconds interrupt is an edge-sensitive interrupt with a dedicated interrupt vector that is generated once a second and requires no software overhead (there is no corresponding status flag to clear). It is enabled in the RTC by the time seconds interrupt enable bit and enabled at the chip level by setting the chip-specific RTC clock gate control bit. The RTC seconds interrupt does not cause the RTC wakeup pin to assert. This interrupt is optional and may not be implemented on all devices.

Chapter 41

Universal Serial Bus OTG Controller (USBOTG)

41.1 Introduction

NOTE

For the chip-specific implementation details of this module's instances see the chip configuration chapter.

This section describes the USB. The OTG implementation in this module provides limited host functionality as well as device solutions for implementing a USB 2.0 full-speed/low-speed compliant peripheral. The OTG implementation supports the On-The-Go (OTG) addendum to the USB 2.0 Specification. Only one protocol can be active at any time. A negotiation protocol must be used to switch to a USB host functionality from a USB device. This is known as the Master Negotiation Protocol (MNP).

41.1.1 USB

The USB is a cable bus that supports data exchange between a host computer and a wide range of simultaneously accessible peripherals. The attached peripherals share USB bandwidth through a host-scheduled, token-based protocol. The bus allows peripherals to be attached, configured, used, and detached while the host and other peripherals are in operation.

USB software provides a uniform view of the system for all application software, hiding implementation details making application software more portable. It manages the dynamic attach and detach of peripherals.

There is only one host in any USB system. The USB interface to the host computer system is referred to as the Host Controller.

There may be multiple USB devices in any system such as joysticks, speakers, printers, etc. USB devices present a standard USB interface in terms of comprehension, response, and standard capability.

The host initiates transactions to specific peripherals, while the device responds to control transactions. The device sends and receives data to and from the host using a standard USB data format. USB 2.0 full-speed /low-speed peripherals operate at 12Mb/s or 1.5 Mb/s.

For additional information, refer to the USB 2.0 specification.

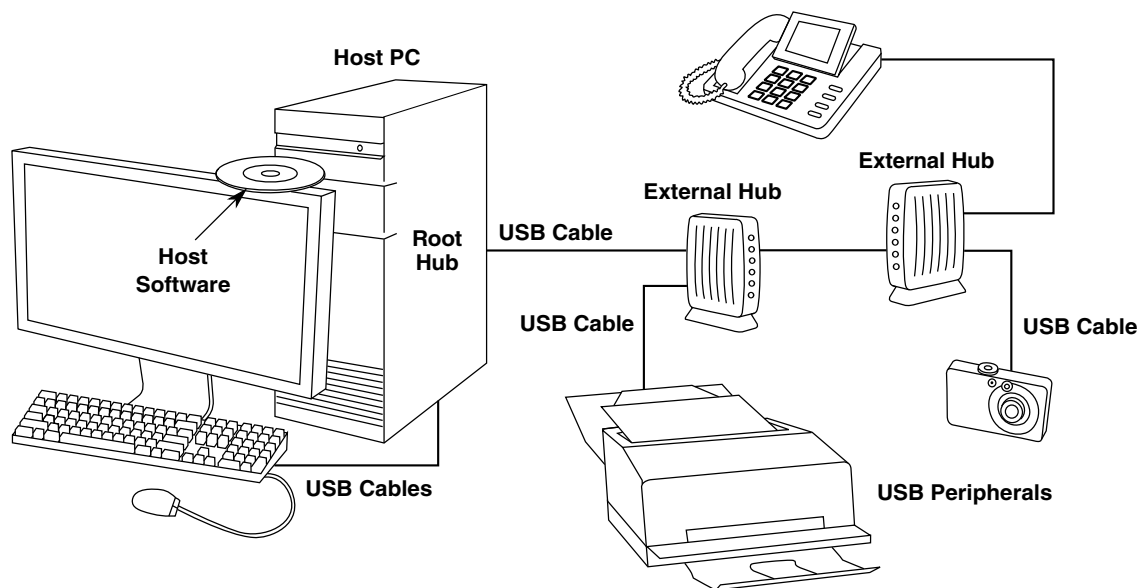

Figure 41-1. Example USB 2.0 System Configuration

41.1.2 USB On-The-Go

USB (Universal Serial Bus) is a popular standard for connecting peripherals and portable consumer electronic devices such as digital cameras and hand-held computers to host PCs. The On-The-Go (OTG) Supplement to the USB Specification extends USB to peer-to-peer application. Using USB OTG technology consumer electronics, peripherals and portable devices can connect to each other (for example, a digital camera can connect directly to a printer, or a keyboard can connect to a Personal Digital Assistant) to exchange data.

With the USB On-The-Go product, you can develop a fully USB-compliant peripheral device that can also assume the role of a USB host. Software determines the role of the device based on hardware signals, and then initializes the device in the appropriate mode of operation (host or peripheral) based on how it is connected. After connecting the devices can negotiate using the OTG protocols to assume the role of host or peripheral based on the task to be accomplished.

For additional information, refer to the *On-The-Go Supplement to the USB 2.0 Specification*.

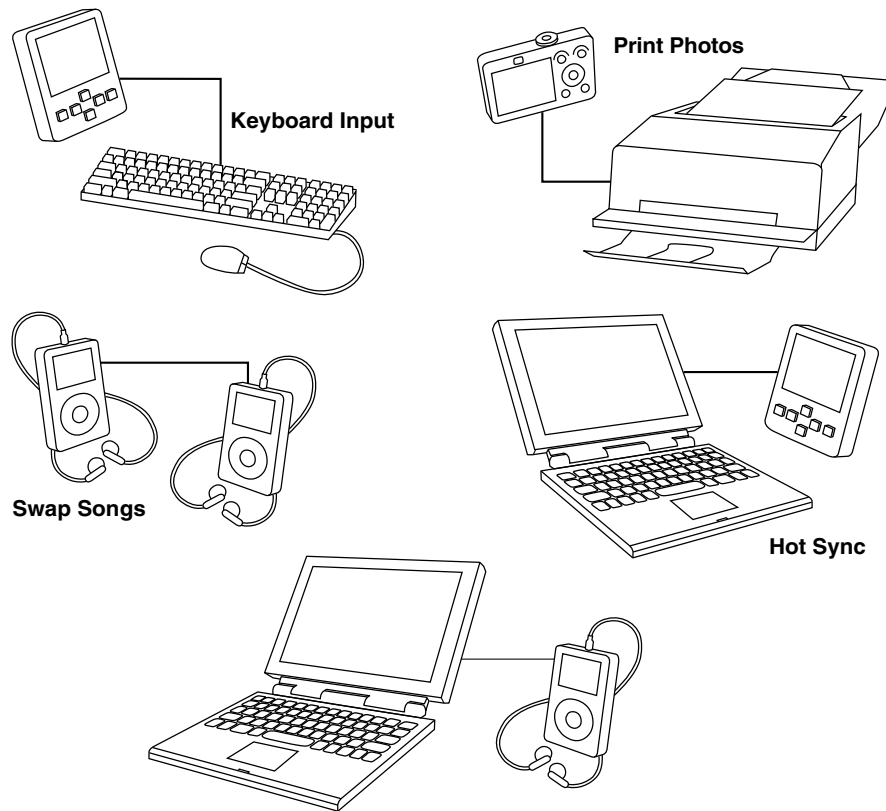

Figure 41-2. Example USB 2.0 On-The-Go Configurations

41.1.3 USB-FS Features

- USB 1.1 and 2.0 compliant full-speed device controller
- 16-Bidirectional end points
- DMA or FIFO data stream interfaces
- Low-power consumption
- On-The-Go protocol logic

41.2 Functional Description

The USB-FS 2.0 full-speed/low-speed module communicates with the processor core through status registers, control registers, and data structures in memory.

41.2.1 Data Structures

The function of the device operation is to transfer a request in the memory image to and from the Universal Serial Bus. To efficiently manage USB endpoint communications the USB-FS implements a Buffer Descriptor Table (BDT) in system memory. See [Figure 41-3](#).

41.3 Programmers Interface

This section discusses the major components of the programming model for the USB module.

41.3.1 Buffer Descriptor Table

To efficiently manage USB endpoint communications the USB-FS implements a Buffer Descriptor Table (BDT) in system memory. The BDT resides on a 512 byte boundary in system memory and is pointed to by the BDT Page Registers. Every endpoint direction requires two eight-byte Buffer Descriptor entries. Therefore, a system with 16 fully bidirectional endpoints would require 512 bytes of system memory to implement the BDT. The two Buffer Descriptor (BD) entries allows for an EVEN BD and ODD BD entry for each endpoint direction. This allows the microprocessor to process one BD while the USB-FS is processing the other BD. Double buffering BDs in this way allows the USB-FS to easily transfer data at the maximum throughput provided by USB.

The software API intelligently manages buffers for the USB-FS by updating the BDT when needed. This allows the USB-FS to efficiently manage data transmission and reception, while the microprocessor performs communication overhead processing and other function dependent applications. Because the buffers are shared between the microprocessor and the USB-FS a simple semaphore mechanism is used to distinguish who is allowed to update the BDT and buffers in system memory. A semaphore bit, the OWN bit, is cleared to 0 when the BD entry is owned by the microprocessor. The microprocessor is allowed read and write access to the BD entry and the buffer in system memory when the OWN bit is 0. When the OWN bit is set to 1, the BD entry and the buffer in system memory are owned by the USB-FS. The USB-FS now has full read and write access and the microprocessor should not modify the BD or its corresponding data buffer. The BD also contains indirect address pointers to where the actual buffer resides in system memory. This indirect address mechanism is shown in the following diagram.

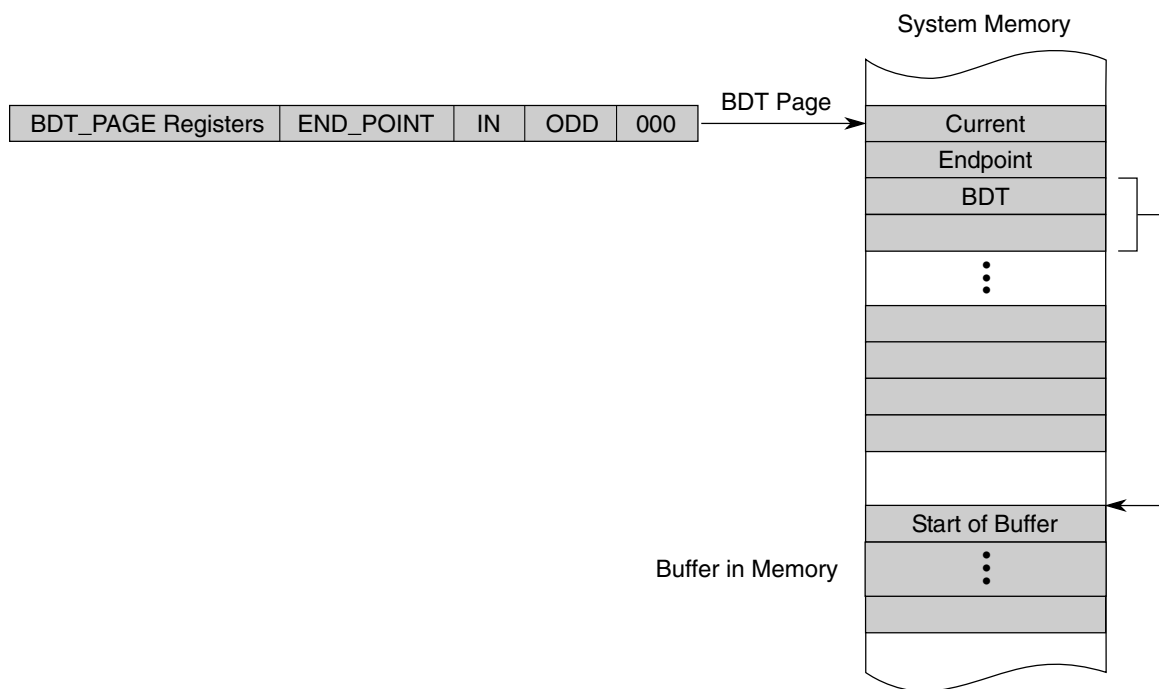

Figure 41-3. Buffer Descriptor Table

41.3.2 Rx vs. Tx as a USB Target Device or USB Host

The USB-FS core uses software control to switch between two modes of operation:

- USB target device
- USB hosts

In either mode, USB host or USB target device, the same data paths and buffer descriptors are used for the transmission and reception of data. For this reason, a USB-FS core centric nomenclature is used to describe the direction of the data transfer between the USB-FS core and the USB:

Rx (or receive)

describes transfers that move data from the USB to memory.

Tx (or transmit)

describes transfers that move data from memory to the USB.

The following table shows how the data direction corresponds to the USB token type in host and target device applications.

Table 41-1. Data Direction for USB Host or USB Target

	Rx	Tx
Device	OUT or Setup	IN

Table continues on the next page...

Table 41-1. Data Direction for USB Host or USB Target (continued)

	Rx	Tx
Host	IN	Out or Setup

41.3.3 Addressing Buffer Descriptor Table Entries

An understanding of the addressing mechanism of the Buffer Descriptor Table is useful when accessing endpoint data via the USB-FS or microprocessor. Some points of interest are:

- The Buffer Descriptor Table occupies up to 512 bytes of system memory.
- 16 bidirectional endpoints can be supported with a full BDT of 512 bytes.
- 16 bytes are needed for each USB endpoint direction.
- Applications with less than 16 endpoints require less RAM to implement the BDT.
- The BDT Page Registers point to the starting location of the BDT.
- The BDT must be located on a 512-byte boundary in system memory.
- All enabled TX and RX endpoint BD entries are indexed into the BDT to allow easy access via the USB-FS or MCU core.

When a USB token on an enabled endpoint is received, the USB-FS uses its integrated DMA controller to interrogate the BDT. The USB-FS reads the corresponding endpoint BD entry to determine if it owns the BD and corresponding buffer in system memory.

To compute the entry point in to the BDT, the BDT_PAGE registers is concatenated with the current endpoint and the TX and ODD fields to form a 32-bit address. This address mechanism is shown in the following diagrams:

Table 41-2. BDT Address Calculation Fields

Field	Description
BDT_PAGE	BDT_PAGE registers in the Control Register Block
END_POINT	END POINT field from the USB TOKEN
TX	1 for an TX transmit transfers and 0 for an RX receive transfers
ODD	This bit is maintained within the USB-FS SIE. It corresponds to the buffer currently in use. The buffers are used in a ping-pong fashion.

41.3.4 Buffer Descriptor Formats

The Buffer Descriptors (BD) provide endpoint buffer control information for the USB-FS and microprocessor. The Buffer Descriptors have different meaning based on whether it is the USB-FS or microprocessor reading the BD in memory.

The USB-FS Controller uses the data stored in the BDs to determine:

- Who owns the buffer in system memory
- Data0 or Data1 PID
- Release Own upon packet completion
- No address increment (FIFO Mode)
- Data toggle synchronization enable
- How much data is to be transmitted or received
- Where the buffer resides in system memory

While the microprocessor uses the data stored in the BDs to determine:

- Who owns the buffer in system memory
- Data0 or Data1 PID
- The received TOKEN PID
- How much data was transmitted or received
- Where the buffer resides in system memory

The format for the BD is shown in the following figure.

Table 41-3. Buffer Descriptor Byte Format

31:26	25:16	15:8	7	6	5	4	3	2	1	0
RSVD	BC (10 bits)	RSVD	OWN	DATA0/1	KEEP/ TOK_PID[3]	NINC/ TOK_PID[2]	DTS/ TOK_PID[1]	BDT_STALL/ TOK_PID[0]	0	0
Buffer Address (32-Bits)										

Table 41-4. Buffer Descriptor Byte Fields

Field	Description
31 –26 RSVD	Reserved
25 –16 BC[9:0]	The Byte Count bits represent the 10-bit Byte Count. The USB-FS SIE changes this field upon the completion of a RX transfer with the byte count of the data received.
15 –8 RSVD	Reserved

Table continues on the next page...

Table 41-4. Buffer Descriptor Byte Fields (continued)

Field	Description
7 OWN	<p>The OWN bit determines whether the microprocessor or the USB-FS currently owns the buffer. Except when KEEP=1, the SIE writes a 0 to this bit when it has completed a token. This byte of the BD should always be the last byte the microprocessor updates when it initializes a BD.</p> <p>0</p> <p>The microprocessor has exclusive access to the BD. The USB-FS ignores all other fields in the BD.</p> <p>1</p> <p>USB-FS has exclusive access to the BD. After the BD has been assigned to the USB-FS, the microprocessor should not change it in any way.</p>
6 DATA0/1	<p>This bit defines if a DATA0 field (DATA0/1=0) or a DATA1 (DATA0/1=1) field was transmitted or received. It is unchanged by the USB-FS.</p>
5 KEEP/ TOK_PID[3]	<p>Typically this bit is set (that is, 1) with ISO endpoints feeding a FIFO. The microprocessor is not informed that a token has been processed, the data is simply transferred to or from the FIFO. If KEEP is set, normally the NINC bit is also set to prevent address increment.</p> <p>0</p> <p>Bit 3 of the current token PID is written back in to the BD by the USB-FS. Allows the USB-FS to release the BD when a token has been processed.</p> <p>1</p> <p>This bit is unchanged by the USB-FS. If the OWN bit also is set, the BD remains owned by the USB-FS forever.</p>
4 NINC/ TOK_PID[2]	<p>The No Increment (NINC) bit disables the DMA engine address increment. This forces the DMA engine to read or write from the same address. This is useful for endpoints when data needs to be read from or written to a single location such as a FIFO. Typically this bit is set with the KEEP bit for ISO endpoints that are interfacing to a FIFO.</p> <p>0</p> <p>the USB-FS writes bit 2 of the current token PID to the BD.</p> <p>1</p> <p>This bit is unchanged by the USB-FS.</p>
3 DTS/ TOK_PID[1]	<p>Setting this bit enables the USB-FS to perform Data Toggle Synchronization.</p> <ul style="list-style-type: none"> • If KEEP=0, bit 1 of the current token PID is written back to the BD. • If KEEP=1, this bit is unchanged by the USB-FS. <p>0</p> <p>Data Toggle Synchronization is disabled.</p> <p>1</p> <p>Enables the USB-FS to perform Data Toggle Synchronization.</p>

Table continues on the next page...

Table 41-4. Buffer Descriptor Byte Fields (continued)

Field	Description
2 BDT_STALL TOK_PID[0]	Setting this bit causes the USB-FS to issue a STALL handshake if a token is received by the SIE that would use the BDT in this location. The BDT is not consumed by the SIE (the owns bit remains set and the rest of the BDT is unchanged) when a BDT-STALL bit is set. <ul style="list-style-type: none"> • If KEEP=0, bit 0 of the current token PID is written back to the BD. • If KEEP=1, this bit is unchanged by the USB-FS. <p>0</p> No stall issued. <p>1</p> The BDT is not consumed by the SIE (the OWN bit remains set and the rest of the BDT is unchanged).
TOK_PID[n]	Bits [5:2] can also represent the current token PID. The current token PID is written back in to the BD by the USB-FS when a transfer completes. The values written back are the token PID values from the USB specification: <ul style="list-style-type: none"> • 0x1 for an OUT token. • 0x9 for an IN token. • 0xd for a SETUP token. In host mode, this field is used to report the last returned PID or a transfer status indication. The possible values returned are: <ul style="list-style-type: none"> • 0x3 DATA0 • 0xb DATA1 • 0x2 ACK • 0xe STALL • 0xa NAK • 0x0 Bus Timeout • 0xf Data Error
1–0 Reserved	Reserved, should read as zeroes.
ADDR[31:0]	The Address bits represent the 32 -bit buffer address in system memory. These bits are unchanged by the USB-FS.

41.3.5 USB Transaction

When the USB-FS transmits or receives data, it computes the BDT address using the address generation shown in "Addressing Buffer Descriptor Entries" table.

If OWN =1, the following process occurs:

1. The USB-FS reads the BDT.
2. The SIE transfers the data via the DMA to or from the buffer pointed to by the ADDR field of the BD.
3. When the TOKEN is complete, the USB-FS updates the BDT and, if KEEP=0, changes the OWN bit to 0.
4. The STAT register is updated and the TOK_DNE interrupt is set.

5. When the microprocessor processes the TOK_DNE interrupt, it reads from the status register all the information needed to process the endpoint.
6. At this point, the microprocessor allocates a new BD so additional USB data can be transmitted or received for that endpoint, and then processes the last BD.

The following figure shows a timeline of how a typical USB token is processed after the BDT is read and OWN=1.

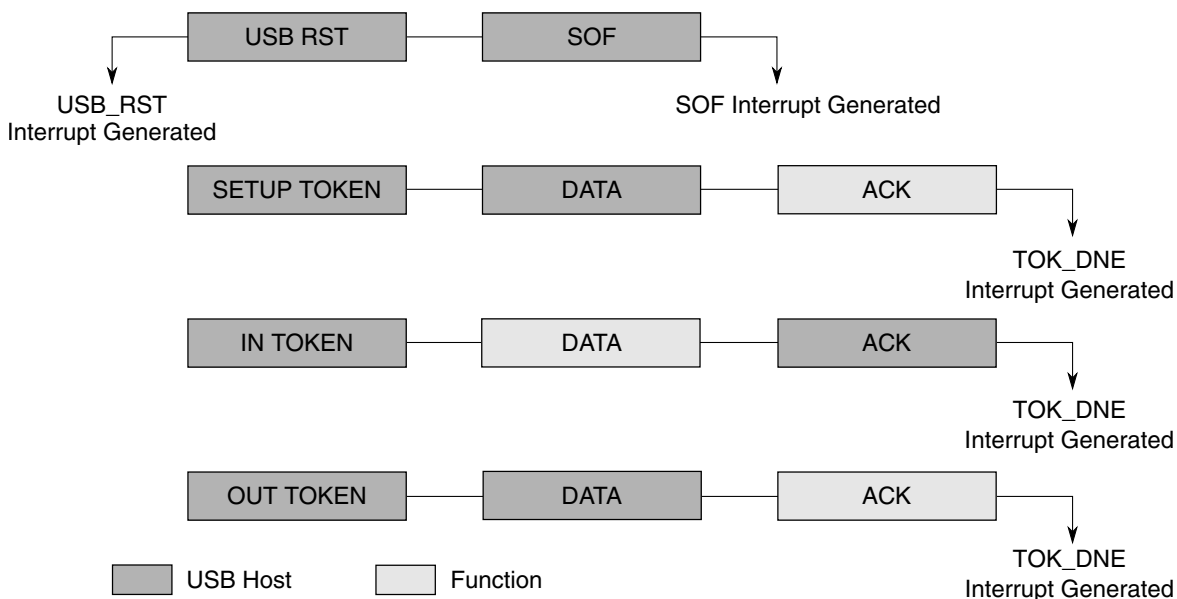

Figure 41-4. USB Token Transaction

The USB has two sources for the DMA overrun error:

Memory Latency

The memory latency on the BVCI initiator interface may be too high and cause the receive FIFO to overflow. This is predominantly a hardware performance issue, usually caused by transient memory access issues.

Oversized Packets

The packet received may be larger than the negotiated *MaxPacket* size. Typically, this is caused by a software bug. For DMA overrun errors due to oversized data packets, the USB specification is ambiguous. It assumes correct software drivers on both sides. NAKing the packet can result in retransmission of the already oversized packet data. Therefore, in response to oversized packets, the USB core continues ACKing the packet for non-isochronous transfers.

Table 41-5. USB Responses to DMA Overrun Errors

Errors due to Memory Latency	Errors due to Oversized Packets
Non-Acknowledgment (NAK) or Bus Timeout (BTO) — See bit 4 in "Error Interrupt Status Register (ERR_STAT)" as appropriate for the class of transaction.	Continues acknowledging (ACKing) the packet for non-isochronous transfers.

Table continues on the next page...

Table 41-5. USB Responses to DMA Overrun Errors (continued)

Errors due to Memory Latency	Errors due to Oversized Packets
—	The data written to memory is clipped to the MaxPacket size so as not to corrupt system memory.
The DMA_ERR bit is set in the ERR_STAT register for host and device modes of operation. Depending on the values of the INT_ENB and ERR_ENB register, the core may assert an interrupt to notify the processor of the DMA error.	Asserts the DMA_ERR bit of the ERR_STAT register (which could trigger an interrupt) and a TOK_DNE interrupt fires. (Note: The TOK_PID field of the BDT is not 1111 because the DMA_ERR is not due to latency).
<ul style="list-style-type: none"> For host mode, the TOK_DNE interrupt fires and the TOK_PID field of the BDT is 1111 to indicate the DMA latency error. Host mode software can decide to retry or move to next scheduled item. In device mode, the BDT is not written back nor is the TOK_DNE interrupt triggered because it is assumed that a second attempt is queued and will succeed in the future. 	The packet length field written back to the BDT is the MaxPacket value that represents the length of the clipped data actually written to memory.
From here, the software can decide an appropriate course of action for future transactions such as stalling the endpoint, canceling the transfer, disabling the endpoint, etc.	

41.4 Memory Map/Register Definitions

This section provides the memory map and detailed descriptions of all USB interface registers.

USB memory map

Absolute address (hex)	Register name	Width (in bits)	Access	Reset value	Section/page
4007_2000	Peripheral ID Register (USB0_PERID)	8	R	04h	41.4.1/1007
4007_2004	Peripheral ID Complement Register (USB0_IDCOMP)	8	R	FBh	41.4.2/1008
4007_2008	Peripheral Revision Register (USB0_REV)	8	R	33h	41.4.3/1008
4007_200C	Peripheral Additional Info Register (USB0_ADDINFO)	8	R	01h	41.4.4/1009
4007_2010	OTG Interrupt Status Register (USB0_OTGISTAT)	8	R/W	00h	41.4.5/1009
4007_2014	OTG Interrupt Control Register (USB0_OTGICR)	8	R/W	00h	41.4.6/1010
4007_2018	OTG Status Register (USB0_OTGSTAT)	8	R/W	00h	41.4.7/1011

Table continues on the next page...

USB memory map (continued)

Absolute address (hex)	Register name	Width (in bits)	Access	Reset value	Section/page
4007_201C	OTG Control Register (USB0_OTGCTL)	8	R/W	00h	41.4.8/1012
4007_2080	Interrupt Status Register (USB0_ISTAT)	8	R/W	00h	41.4.9/1013
4007_2084	Interrupt Enable Register (USB0_INTEN)	8	R/W	00h	41.4.10/1014
4007_2088	Error Interrupt Status Register (USB0_ERRSTAT)	8	R/W	00h	41.4.11/1015
4007_208C	Error Interrupt Enable Register (USB0_ERREN)	8	R/W	00h	41.4.12/1016
4007_2090	Status Register (USB0_STAT)	8	R	00h	41.4.13/1018
4007_2094	Control Register (USB0_CTL)	8	R/W	00h	41.4.14/1019
4007_2098	Address Register (USB0_ADDR)	8	R/W	00h	41.4.15/1020
4007_209C	BDT Page Register 1 (USB0_BDTPAGE1)	8	R/W	00h	41.4.16/1021
4007_20A0	Frame Number Register Low (USB0_FRMNUML)	8	R/W	00h	41.4.17/1021
4007_20A4	Frame Number Register High (USB0_FRMNUMH)	8	R/W	00h	41.4.18/1022
4007_20A8	Token Register (USB0_TOKEN)	8	R/W	00h	41.4.19/1022
4007_20AC	SOF Threshold Register (USB0_SOFTHLD)	8	R/W	00h	41.4.20/1023
4007_20B0	BDT Page Register 2 (USB0_BDTPAGE2)	8	R/W	00h	41.4.21/1024
4007_20B4	BDT Page Register 3 (USB0_BDTPAGE3)	8	R/W	00h	41.4.22/1024
4007_20C0	Endpoint Control Register (USB0_ENDPT0)	8	R/W	00h	41.4.23/1024
4007_20C4	Endpoint Control Register (USB0_ENDPT1)	8	R/W	00h	41.4.23/1024
4007_20C8	Endpoint Control Register (USB0_ENDPT2)	8	R/W	00h	41.4.23/1024
4007_20CC	Endpoint Control Register (USB0_ENDPT3)	8	R/W	00h	41.4.23/1024
4007_20D0	Endpoint Control Register (USB0_ENDPT4)	8	R/W	00h	41.4.23/1024

Table continues on the next page...

USB memory map (continued)

Absolute address (hex)	Register name	Width (in bits)	Access	Reset value	Section/page
4007_20D4	Endpoint Control Register (USB0_ENDPT5)	8	R/W	00h	41.4.23/1024
4007_20D8	Endpoint Control Register (USB0_ENDPT6)	8	R/W	00h	41.4.23/1024
4007_20DC	Endpoint Control Register (USB0_ENDPT7)	8	R/W	00h	41.4.23/1024
4007_20E0	Endpoint Control Register (USB0_ENDPT8)	8	R/W	00h	41.4.23/1024
4007_20E4	Endpoint Control Register (USB0_ENDPT9)	8	R/W	00h	41.4.23/1024
4007_20E8	Endpoint Control Register (USB0_ENDPT10)	8	R/W	00h	41.4.23/1024
4007_20EC	Endpoint Control Register (USB0_ENDPT11)	8	R/W	00h	41.4.23/1024
4007_20F0	Endpoint Control Register (USB0_ENDPT12)	8	R/W	00h	41.4.23/1024
4007_20F4	Endpoint Control Register (USB0_ENDPT13)	8	R/W	00h	41.4.23/1024
4007_20F8	Endpoint Control Register (USB0_ENDPT14)	8	R/W	00h	41.4.23/1024
4007_20FC	Endpoint Control Register (USB0_ENDPT15)	8	R/W	00h	41.4.23/1024
4007_2100	USB Control Register (USB0_USBCTRL)	8	R/W	C0h	41.4.24/1026
4007_2104	USB OTG Observe Register (USB0_OBSERVE)	8	R	50h	41.4.25/1026
4007_2108	USB OTG Control Register (USB0_CONTROL)	8	R/W	00h	41.4.26/1027
4007_210C	USB Transceiver Control Register 0 (USB0_USBTRC0)	8	R/W	00h	41.4.27/1028

41.4.1 Peripheral ID Register (USBx_PERID)

The Peripheral ID Register reads back the value of 0x04. This value is defined for the USB Peripheral.

Addresses: USB0_PERID is 4007_2000h base + 0h offset = 4007_2000h

Bit	7	6	5	4	3	2	1	0
Read	0		ID					
Write								
Reset	0	0	0	0	0	1	0	0

USBx_PERID field descriptions

Field	Description
7–6 Reserved	This read-only field is reserved and always has the value zero.
5–0 ID	Peripheral identification bits These bits always read 0x04 (00_0100)

41.4.2 Peripheral ID Complement Register (USBx_IDCOMP)

The Peripheral ID Complement Register reads back the complement of the Peripheral ID Register. For the USB Peripheral, this is the value 0xFB.

Addresses: USB0_IDCOMP is 4007_2000h base + 4h offset = 4007_2004h

Bit	7	6	5	4	3	2	1	0
Read	1		NID					
Write								
Reset	1	1	1	1	1	0	1	1

USBx_IDCOMP field descriptions

Field	Description
7–6 Reserved	This read-only field is reserved and always has the value one. These bits always read ones
5–0 NID	Ones complement of peripheral identification bits.

41.4.3 Peripheral Revision Register (USBx_REV)

This register contains the revision number of the USB Module.

Addresses: USB0_REV is 4007_2000h base + 8h offset = 4007_2008h

Bit	7	6	5	4	3	2	1	0
Read	REV							
Write								
Reset	0	0	1	1	0	0	1	1

USBx_REV field descriptions

Field	Description
7–0 REV	Revision Indicate the revision number of the USB Core.

41.4.4 Peripheral Additional Info Register (USBx_ADDINFO)

The Peripheral Additional info Register reads back the value of the fixed Interrupt Request Level (IRQNUM) along with the Host Enable bit. If set to 1, the Host Enable bit indicates the USB peripheral is operating in host mode.

Addresses: USB0_ADDINFO is 4007_2000h base + Ch offset = 4007_200Ch

Bit	7	6	5	4	3	2	1	0
Read	IRQNUM				0		IEHOST	
Write	[Greyed out]				[Greyed out]		[Greyed out]	
Reset	0	0	0	0	0	0	0	1

USBx_ADDINFO field descriptions

Field	Description
7-3 IRQNUM	Assigned Interrupt Request Number
2-1 Reserved	This read-only field is reserved and always has the value zero.
0 IEHOST	This bit is set if host mode is enabled.

41.4.5 OTG Interrupt Status Register (USBx_OTGISTAT)

The OTG Interrupt Status Register records changes of the ID sense and VBUS signals. Software can read this register to determine which event has caused an interrupt. Only bits that have changed since the last software read are set. Writing a one to a bit clears the associated interrupt.

Addresses: USB0_OTGISTAT is 4007_2000h base + 10h offset = 4007_2010h

Bit	7	6	5	4	3	2	1	0
Read	IDCHG	ONEMSEC	LINE_STATE_CHG	0	SESSVLDCHG	B_SESS_CHG	0	AVBUSCHG
Write	[Greyed out]	[Greyed out]	[Greyed out]	[Greyed out]	[Greyed out]	[Greyed out]	[Greyed out]	[Greyed out]
Reset	0	0	0	0	0	0	0	0

USBx_OTGISTAT field descriptions

Field	Description
7 IDCHG	This bit is set when a change in the ID Signal from the USB connector is sensed.
6 ONEMSEC	This bit is set when the 1 millisecond timer expires. This bit stays asserted until cleared by software. The interrupt must be serviced every millisecond to avoid losing 1msec counts.

Table continues on the next page...

USBx_OTGISTAT field descriptions (continued)

Field	Description
5 LINE_STATE_CHG	This bit is set when the USB line state changes. The interrupt associated with this bit can be used to detect Reset, Resume, Connect, and Data Line Pulse signals.
4 Reserved	This read-only field is reserved and always has the value zero.
3 SESSVLDCHG	This bit is set when a change in VBUS is detected indicating a session valid or a session no longer valid.
2 B_SESS_CHG	This bit is set when a change in VBUS is detected on a B device.
1 Reserved	This read-only field is reserved and always has the value zero.
0 AVBUSCHG	This bit is set when a change in VBUS is detected on an A device.

41.4.6 OTG Interrupt Control Register (USBx_OTGICR)

The OTG Interrupt Control Register enables the corresponding interrupt status bits defined in the OTG Interrupt Status Register.

Addresses: USB0_OTGICR is 4007_2000h base + 14h offset = 4007_2014h

Bit	7	6	5	4	3	2	1	0
Read	IDEN	ONEMSECEN	LINESTATEEN	0	SESSVLDEN	BSESSEN	0	AVBUSEN
Write								
Reset	0	0	0	0	0	0	0	0

USBx_OTGICR field descriptions

Field	Description
7 IDEN	ID interrupt enable 0 The ID interrupt is disabled 1 The ID interrupt is enabled
6 ONEMSECEN	1 millisecond interrupt enable 0 The 1msec timer interrupt is disabled. 1 The 1msec timer interrupt is enabled.
5 LINESTATEEN	Line State change interrupt enable 0 The LINE_STAT_CHG interrupt is disabled. 1 The LINE_STAT_CHG interrupt is enabled
4 Reserved	This read-only field is reserved and always has the value zero.

Table continues on the next page...

USBx_OTGICR field descriptions (continued)

Field	Description
3 SESSVLDEN	Session valid interrupt enable 0 The SESSVLDCHG interrupt is disabled. 1 The SESSVLDCHG interrupt is enabled.
2 BSESSEN	B Session END interrupt enable 0 The B_SESS_CHG interrupt is disabled 1 The B_SESS_CHG interrupt is enabled
1 Reserved	This read-only field is reserved and always has the value zero.
0 AVBUSEN	A VBUS Valid interrupt enable 0 The AVBUSCHG interrupt is disabled 1 The AVBUSCHG interrupt is enabled

41.4.7 OTG Status Register (USBx_OTGSTAT)

The OTG Status Register displays the actual value from the external comparator outputs of the ID pin and VBUS.

Addresses: USB0_OTGSTAT is 4007_2000h base + 18h offset = 4007_2018h

Bit	7	6	5	4	3	2	1	0
Read	ID	ONEMSECEN	LINESTATESTABLE	0	SESS_VLD	BSESSEND	0	AVBUSVLD
Write								
Reset	0	0	0	0	0	0	0	0

USBx_OTGSTAT field descriptions

Field	Description
7 ID	Indicates the current state of the ID pin on the USB connector 0 Indicates a Type A cable has been plugged into the USB connector 1 Indicates no cable is attached or a Type B cable has been plugged into the USB connector
6 ONEMSECEN	This bit is reserved for the 1msec count, but it is not useful to software.
5 LINESTATESTABLE	This bit indicates that the internal signals that control the LINE_STATE_CHG bit (bit 5) of the OTGSTAT register have been stable for at least 1 millisecond. First read the LINE_STATE_CHG bit, and then read this bit. If this bit reads as 1, then the value of LINE_STATE_CHG can be considered stable.

Table continues on the next page...

USBx_OTGSTAT field descriptions (continued)

Field	Description
	0 The LINE_STAT_CHG bit is not yet stable. 1 The LINE_STAT_CHG bit has been debounced and is stable.
4 Reserved	This read-only field is reserved and always has the value zero.
3 SESS_VLD	Session valid 0 The VBUS voltage is below the B session Valid threshold 1 The VBUS voltage is above the B session Valid threshold.
2 BSESSEND	B Session END 0 The VBUS voltage is above the B session End threshold. 1 The VBUS voltage is below the B session End threshold.
1 Reserved	This read-only field is reserved and always has the value zero.
0 AVBUSVLD	A VBUS Valid 0 The VBUS voltage is below the A VBUS Valid threshold. 1 The VBUS voltage is above the A VBUS Valid threshold.

41.4.8 OTG Control Register (USBx_OTGCTL)

The OTG Control Register controls the operation of VBUS and Data Line termination resistors.

Addresses: USB0_OTGCTL is 4007_2000h base + 1Ch offset = 4007_201Ch

Bit	7	6	5	4	3	2	1	0
Read	DPHIGH	0	DPLOW	DMLow	0	OTGEN	0	
Write								
Reset	0	0	0	0	0	0	0	0

USBx_OTGCTL field descriptions

Field	Description
7 DPHIGH	D+ Data Line pullup resistor enable 0 D+ pullup resistor is not enabled 1 D+ pullup resistor is enabled
6 Reserved	This read-only field is reserved and always has the value zero.
5 DPLOW	D+ Data Line pull-down resistor enable This bit should always be enabled together with bit 4 (DMLow)

Table continues on the next page...

USBx_OTGCTL field descriptions (continued)

Field	Description
	0 D+ pulldown resistor is not enabled. 1 D+ pulldown resistor is enabled.
4 DMLow	D- Data Line pull-down resistor enable 0 D- pulldown resistor is not enabled. 1 D- pulldown resistor is enabled.
3 Reserved	This read-only field is reserved and always has the value zero.
2 OTGEN	On-The-Go pullup/pulldown resistor enable 0 If USB_EN is set and HOST_MODE is clear in the Control Register (CTL), then the D+ Data Line pull-up resistors are enabled. If HOST_MODE is set the D+ and D- Data Line pull-down resistors are engaged. 1 The pull-up and pull-down controls in this register are used.
1-0 Reserved	This read-only field is reserved and always has the value zero.

41.4.9 Interrupt Status Register (USBx_ISTAT)

The Interrupt Status Register contains bits for each of the interrupt sources within the USB Module. Each of these bits are qualified with their respective interrupt enable bits. All bits of this register are logically OR'd together along with the OTG Interrupt Status Register (OTGSTAT) to form a single interrupt source for the processor's interrupt controller. After an interrupt bit has been set it may only be cleared by writing a one to the respective interrupt bit. This register contains the value of 0x00 after a reset.

Addresses: USB0_ISTAT is 4007_2000h base + 80h offset = 4007_2080h

Bit	7	6	5	4	3	2	1	0
Read	STALL	ATTACH	RESUME	SLEEP	TOKDNE	SOFTOK	ERROR	USBRST
Write	w1c	w1c	w1c	w1c	w1c	w1c	w1c	w1c
Reset	0	0	0	0	0	0	0	0

USBx_ISTAT field descriptions

Field	Description
7 STALL	Stall Interrupt In Target mode this bit is asserted when a STALL handshake is sent by the SIE. In Host mode this bit is set when the USB Module detects a STALL acknowledge during the handshake phase of a USB transaction. This interrupt can be use to determine is the last USB transaction was completed successfully or if it stalled.
6 ATTACH	Attach Interrupt

Table continues on the next page...

USBx_ISTAT field descriptions (continued)

Field	Description
	This bit is set when the USB Module detects an attach of a USB device. This signal is only valid if HOSTMODEEN is true. This interrupt signifies that a peripheral is now present and must be configured.
5 RESUME	This bit is set depending upon the DP/DM signals, and can be used to signal remote wake-up signaling on the USB bus. When not in suspend mode this interrupt should be disabled.
4 SLEEP	This bit is set when the USB Module detects a constant idle on the USB bus for 3 milliseconds. The sleep timer is reset by activity on the USB bus.
3 TOKDNE	This bit is set when the current token being processed has completed. The processor should immediately read the STAT register to determine the EndPoint and BD used for this token. Clearing this bit (by writing a one) causes the STAT register to be cleared or the STAT holding register to be loaded into the STAT register.
2 SOFTOK	This bit is set when the USB Module receives a Start Of Frame (SOF) token. In Host mode this bit is set when the SOF threshold is reached, so that software can prepare for the next SOF.
1 ERROR	This bit is set when any of the error conditions within the ERRSTAT register occur. The processor must then read the ERRSTAT register to determine the source of the error.
0 USBRST	This bit is set when the USB Module has decoded a valid USB reset. This informs the Microprocessor that it should write 0x00 into the address register and enable endpoint 0. USBRST is set after a USB reset has been detected for 2.5 microseconds. It is not asserted again until the USB reset condition has been removed and then reasserted.

41.4.10 Interrupt Enable Register (USBx_INTEN)

The Interrupt Enable Register contains enable bits for each of the interrupt sources within the USB Module. Setting any of these bits enables the respective interrupt source in the ISTAT register. This register contains the value of 0x00 after a reset.

Addresses: USB0_INTEN is 4007_2000h base + 84h offset = 4007_2084h

Bit	7	6	5	4	3	2	1	0
Read	STALLEN	ATTACHEN	RESUMEEN	SLEEPEN	TOKDNEEN	SOFTOKEN	ERROREN	USBRSTEN
Write								
Reset	0	0	0	0	0	0	0	0

USBx_INTEN field descriptions

Field	Description
7 STALLEN	STALL Interrupt Enable 0 The STALL interrupt is not enabled. 1 The STALL interrupt is enabled.
6 ATTACHEN	ATTACH Interrupt Enable 0 The ATTACH interrupt is not enabled. 1 The ATTACH interrupt is enabled.

Table continues on the next page...

USBx_INTEN field descriptions (continued)

Field	Description
5 RESUMEEN	RESUME Interrupt Enable 0 The RESUME interrupt is not enabled. 1 The RESUME interrupt is enabled.
4 SLEEPEN	SLEEP Interrupt Enable 0 The SLEEP interrupt is not enabled. 1 The SLEEP interrupt is enabled.
3 TOKDNEEN	TOKDNE Interrupt Enable 0 The TOKDNE interrupt is not enabled. 1 The TOKDNE interrupt is enabled.
2 SOFTOKEN	SOFTOK Interrupt Enable 0 The SOFTOK interrupt is not enabled. 1 The SOFTOK interrupt is enabled.
1 ERROREN	ERROR Interrupt Enable 0 The ERROR interrupt is not enabled. 1 The ERROR interrupt is enabled.
0 USBRSTEN	USBRST Interrupt Enable 0 The USBRST interrupt is not enabled. 1 The USBRST interrupt is enabled.

41.4.11 Error Interrupt Status Register (USBx_ERRSTAT)

The Error Interrupt Status Register contains enable bits for each of the error sources within the USB Module. Each of these bits are qualified with their respective error enable bits. All bits of this Register are logically OR'd together and the result placed in the ERROR bit of the ISTAT register. After an interrupt bit has been set it may only be cleared by writing a one to the respective interrupt bit. Each bit is set as soon as the error conditions is detected. Therefore, the interrupt does not typically correspond with the end of a token being processed. This register contains the value of 0x00 after a reset.

Addresses: USB0_ERRSTAT is 4007_2000h base + 88h offset = 4007_2088h

Bit	7	6	5	4	3	2	1	0
Read	BTSERR	0	DMAERR	BTOERR	DFN8	CRC16	CRC5EOF	PIDERR
Write	w1c		w1c	w1c	w1c	w1c	w1c	w1c
Reset	0	0	0	0	0	0	0	0

USBx_ERRSTAT field descriptions

Field	Description
7 BTSERR	This bit is set when a bit stuff error is detected. If set, the corresponding packet is rejected due to the error.
6 Reserved	This read-only field is reserved and always has the value zero.
5 DMAERR	This bit is set if the USB Module has requested a DMA access to read a new BDT but has not been given the bus before it needs to receive or transmit data. If processing a TX transfer this would cause a transmit data underflow condition. If processing a RX transfer this would cause a receive data overflow condition. This interrupt is useful when developing device arbitration hardware for the microprocessor and the USB Module to minimize bus request and bus grant latency. This bit is also set if a data packet to or from the host is larger than the buffer size allocated in the BDT. In this case the data packet is truncated as it is put into buffer memory.
4 BTOERR	This bit is set when a bus turnaround timeout error occurs. The USB Module contains a bus turnaround timer that keeps track of the amount of time elapsed between the token and data phases of a SETUP or OUT TOKEN or the data and handshake phases of a IN TOKEN. If more than 16 bit times are counted from the previous EOP before a transition from IDLE, a bus turnaround timeout error occurs.
3 DFN8	This bit is set if the data field received was not 8 bits in length. USB Specification 1.0 requires that data fields be an integral number of bytes. If the data field was not an integral number of bytes, this bit is set.
2 CRC16	This bit is set when a data packet is rejected due to a CRC16 error.
1 CRC5EOF	This error interrupt has two functions. When the USB Module is operating in peripheral mode (HOSTMODEEN=0), this interrupt detects CRC5 errors in the token packets generated by the host. If set the token packet was rejected due to a CRC5 error. When the USB Module is operating in host mode (HOSTMODEEN=1), this interrupt detects End Of Frame (EOF) error conditions. This occurs when the USB Module is transmitting or receiving data and the SOF counter reaches zero. This interrupt is useful when developing USB packet scheduling software to ensure that no USB transactions cross the start of the next frame.
0 PIDERR	This bit is set when the PID check field fails.

41.4.12 Error Interrupt Enable Register (USBx_ERREN)

The Error Interrupt Enable Register contains enable bits for each of the error interrupt sources within the USB Module. Setting any of these bits enables the respective interrupt source in the ERRSTAT register. Each bit is set as soon as the error conditions is detected. Therefore, the interrupt does not typically correspond with the end of a token being processed. This register contains the value of 0x00 after a reset.

Addresses: USB0_ERREN is 4007_2000h base + 8Ch offset = 4007_208Ch

Bit	7	6	5	4	3	2	1	0
Read	BTSERREN	0	DMAERREN	BTOERREN	DFN8EN	CRC16EN	CRC5EOFEN	PIDERREN
Write								
Reset	0	0	0	0	0	0	0	0

USBx_ERREN field descriptions

Field	Description
7 BTSERREN	BTSERR Interrupt Enable 0 The BTSERR interrupt is not enabled. 1 The BTSERR interrupt is enabled.
6 Reserved	This read-only field is reserved and always has the value zero.
5 DMAERREN	DMAERR Interrupt Enable 0 The DMAERR interrupt is not enabled. 1 The DMAERR interrupt is enabled.
4 BTOERREN	BTOERR Interrupt Enable 0 The BTOERR interrupt is not enabled. 1 The BTOERR interrupt is enabled.
3 DFN8EN	DFN8 Interrupt Enable 0 The DFN8 interrupt is not enabled. 1 The DFN8 interrupt is enabled.
2 CRC16EN	CRC16 Interrupt Enable 0 The CRC16 interrupt is not enabled. 1 The CRC16 interrupt is enabled.
1 CRC5EOFEN	CRC5/EOF Interrupt Enable 0 The CRC5/EOF interrupt is not enabled. 1 The CRC5/EOF interrupt is enabled.
0 PIDERREN	PIDERR Interrupt Enable 0 The PIDERR interrupt is not enabled. 1 The PIDERR interrupt is enabled.

41.4.13 Status Register (USBx_STAT)

The Status Register reports the transaction status within the USB Module. When the processor's interrupt controller has received a TOKDNE interrupt the Status Register should be read to determine the status of the previous endpoint communication. The data in the status register is valid when the TOKDNE interrupt bit is asserted. The STAT register is actually a read window into a status FIFO maintained by the USB Module. When the USB Module uses a BD, it updates the Status Register. If another USB transaction is performed before the TOKDNE interrupt is serviced, the USB Module stores the status of the next transaction in the STAT FIFO. Thus the STAT register is actually a four byte FIFO that allows the processor core to process one transaction while the SIE is processing the next transaction. Clearing the TOKDNE bit in the ISTAT register causes the SIE to update the STAT register with the contents of the next STAT value. If the data in the STAT holding register is valid, the SIE immediately reasserts to TOKDNE interrupt.

Addresses: USB0_STAT is 4007_2000h base + 90h offset = 4007_2090h

Bit	7	6	5	4	3	2	1	0
Read	ENDP				TX	ODD	0	
Write								
Reset	0	0	0	0	0	0	0	0

USBx_STAT field descriptions

Field	Description
7-4 ENDP	This four-bit field encodes the endpoint address that received or transmitted the previous token. This allows the processor core to determine which BDT entry was updated by the last USB transaction.
3 TX	Transmit Indicator 0 The most recent transaction was a Receive operation. 1 The most recent transaction was a Transmit operation.
2 ODD	this bit is set if the last Buffer Descriptor updated was in the odd bank of the BDT.
1-0 Reserved	This read-only field is reserved and always has the value zero.

41.4.14 Control Register (USBx_CTL)

The Control Register provides various control and configuration information for the USB Module.

Addresses: USB0_CTL is 4007_2000h base + 94h offset = 4007_2094h

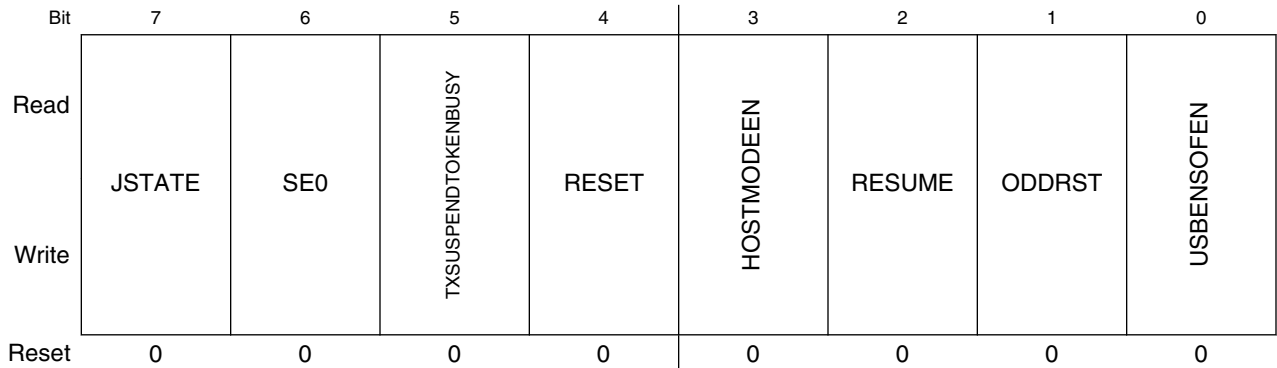

USBx_CTL field descriptions

Field	Description
7 JSTATE	Live USB differential receiver JSTATE signal The polarity of this signal is affected by the current state of LSEN .
6 SE0	Live USB Single Ended Zero signal
5 TXSUSPENDTOKENBUSY	When the USB Module is in Host mode TOKEN_BUSY is set when the USB Module is busy executing a USB token and no more token commands should be written to the Token Register. Software should check this bit before writing any tokens to the Token Register to ensure that token commands are not lost. In Target mode TXD_SUSPEND is set when the SIE has disabled packet transmission and reception. Clearing this bit allows the SIE to continue token processing. This bit is set by the SIE when a Setup Token is received allowing software to dequeue any pending packet transactions in the BDT before resuming token processing.
4 RESET	Setting this bit enables the USB Module to generate USB reset signaling. This allows the USB Module to reset USB peripherals. This control signal is only valid in Host mode (HOSTMODEEN=1). Software must set RESET to 1 for the required amount of time and then clear it to 0 to end reset signaling. For more information on RESET signaling see Section 7.1.4.3 of the USB specification version 1.0.
3 HOSTMODEEN	When set to 1, this bit enables the USB Module to operate in Host mode. In host mode, the USB module performs USB transactions under the programmed control of the host processor.
2 RESUME	When set to 1 this bit enables the USB Module to execute resume signaling. This allows the USB Module to perform remote wake-up. Software must set RESUME to 1 for the required amount of time and then clear it to 0. If the HOSTMODEEN bit is set, the USB module appends a Low Speed End of Packet to the Resume signaling when the RESUME bit is cleared. For more information on RESUME signaling see Section 7.1.4.5 of the USB specification version 1.0.
1 ODDRST	Setting this bit to 1 resets all the BDT ODD ping/pong bits to 0, which then specifies the EVEN BDT bank.

Table continues on the next page...

USBx_CTL field descriptions (continued)

Field	Description
0 USBENSOFEN	<p>USB Enable</p> <p>Setting this bit causes the SIE to reset all of its ODD bits to the BDTs. Therefore, setting this bit resets much of the logic in the SIE. When host mode is enabled, clearing this bit causes the SIE to stop sending SOF tokens.</p> <p>0 The USB Module is disabled. 1 The USB Module is enabled.</p>

41.4.15 Address Register (USBx_ADDR)

The Address Register holds the unique USB address that the USB Module decodes when in Peripheral mode (HOSTMODEEN=0). When operating in Host mode (HOSTMODEEN=1) the USB Module transmits this address with a TOKEN packet. This enables the USB Module to uniquely address an USB peripheral. In either mode, the USB_EN bit within the control register must be set. The Address Register is reset to 0x00 after the reset input becomes active or the USB Module decodes a USB reset signal. This action initializes the Address Register to decode address 0x00 as required by the USB specification.

Addresses: USB0_ADDR is 4007_2000h base + 98h offset = 4007_2098h

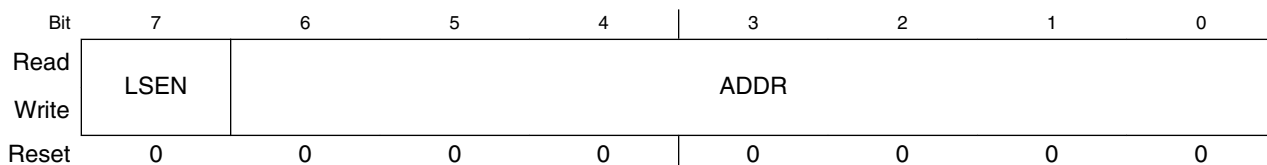

USBx_ADDR field descriptions

Field	Description
7 LSEN	<p>Low Speed Enable bit</p> <p>This bit informs the USB Module that the next token command written to the token register must be performed at low speed. This enables the USB Module to perform the necessary preamble required for low-speed data transmissions.</p>
6-0 ADDR	<p>USB address</p> <p>This 7-bit value defines the USB address that the USB Module decodes in peripheral mode, or transmit when in host mode.</p>

41.4.16 BDT Page Register 1 (USBx_BDTPAGE1)

The Buffer Descriptor Table Page Register 1 provides address bits 15 through 9 of the base address where the current Buffer Descriptor Table (BDT) resides in system memory. The 32-bit BDT Base Address is always aligned on 512-byte boundaries, so bits 8 through 0 of the base address are always taken as zero.

Addresses: USB0_BDTPAGE1 is 4007_2000h base + 9Ch offset = 4007_209Ch

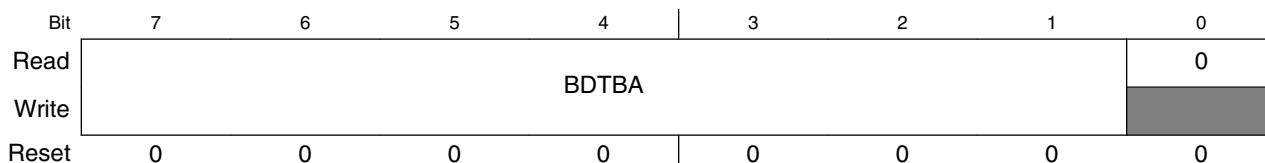

USBx_BDTPAGE1 field descriptions

Field	Description
7-1 BDTBA	This field provides address bits 15 through 9 of the BDT base address.
0 Reserved	This read-only field is reserved and always has the value zero.

41.4.17 Frame Number Register Low (USBx_FRMNUML)

The Frame Number Register (Low and High) contains an 11-bit value used to compute the address where the current Buffer Descriptor Table (BDT) resides in system memory.

Addresses: USB0_FRMNUML is 4007_2000h base + A0h offset = 4007_20A0h

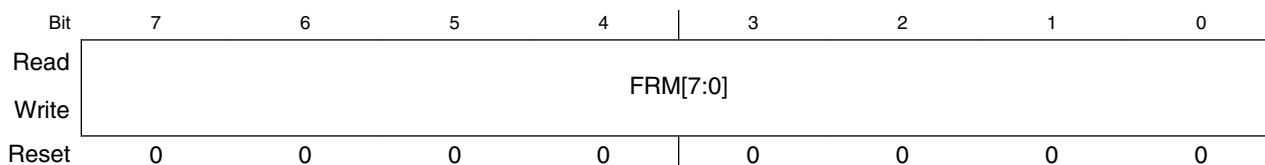

USBx_FRMNUML field descriptions

Field	Description
7-0 FRM[7:0]	This 8-bit field and the 3-bit field in the Frame Number Register High are used to compute the address where the current Buffer Descriptor Table (BDT) resides in system memory.

41.4.18 Frame Number Register High (USBx_FRMNUMH)

The Frame Number Register (Low and High) contains an 11-bit value used to compute the address where the current Buffer Descriptor Table (BDT) resides in system memory.

Addresses: USB0_FRMNUMH is 4007_2000h base + A4h offset = 4007_20A4h



USBx_FRMNUMH field descriptions

Field	Description
7-3 Reserved	This read-only field is reserved and always has the value zero.
2-0 FRM[10:8]	This 3-bit field and the 8-bit field in the Frame Number Register Low are used to compute the address where the current Buffer Descriptor Table (BDT) resides in system memory.

41.4.19 Token Register (USBx_TOKEN)

The Token Register is used to perform USB transactions when in host mode (HOSTMODEEN=1). When the processor core wishes to execute a USB transaction to a peripheral, it writes the TOKEN type and endpoint to this register. After this register has been written, the USB module begins the specified USB transaction to the address contained in the address register. The processor core should always check that the TOKEN_BUSY bit in the control register is not set before performing a write to the Token Register. This ensures token commands are not overwritten before they can be executed. The address register and endpoint control register 0 are also used when performing a token command and therefore must also be written before the Token Register. The address register is used to correctly select the USB peripheral address transmitted by the token command. The endpoint control register determines the handshake and retry policies used during the transfer.

Addresses: USB0_TOKEN is 4007_2000h base + A8h offset = 4007_20A8h

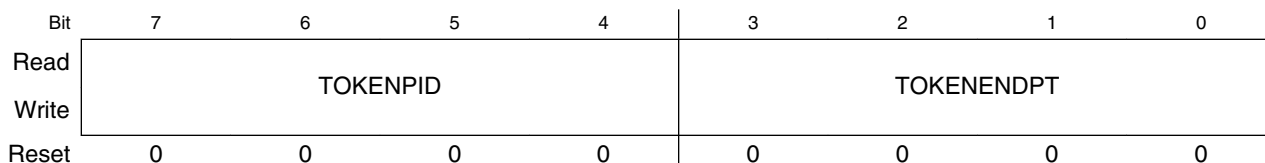

USBx_TOKEN field descriptions

Field	Description
7-4 TOKENPID	This 4-bit field contains the token type executed by the USB Module. 0001 OUT Token. USB Module performs an OUT (TX) transaction. 1001 IN Token. USB Module performs an In (RX) transaction. 1101 SETUP Token. USB Module performs a SETUP (TX) transaction
3-0 TOKENENDPT	This 4 bit field holds the Endpoint address for the token command. The four bit value written must be a valid endpoint.

41.4.20 SOF Threshold Register (USBx_SOFTHLD)

The SOF Threshold Register is used only in Hosts mode (HOSTMODEEN=1). When in Host mode, the 14-bit SOF counter counts the interval between SOF frames. The SOF must be transmitted every 1msec so the SOF counter is loaded with a value of 12000. When the SOF counter reaches zero, a Start Of Frame (SOF) token is transmitted. The SOF threshold register is used to program the number of USB byte times before the SOF to stop initiating token packet transactions. This register must be set to a value that ensures that other packets are not actively being transmitted when the SOF time counts to zero. When the SOF counter reaches the threshold value, no more tokens are transmitted until after the SOF has been transmitted. The value programmed into the threshold register must reserve enough time to ensure the worst case transaction completes. In general the worst case transaction is a IN token followed by a data packet from the target followed by the response from the host. The actual time required is a function of the maximum packet size on the bus. Typical values for the SOF threshold are: 64-byte packets=74; 32-byte packets=42; 16-byte packets=26; 8-byte packets=18.

Addresses: USB0_SOFTHLD is 4007_2000h base + ACh offset = 4007_20ACh

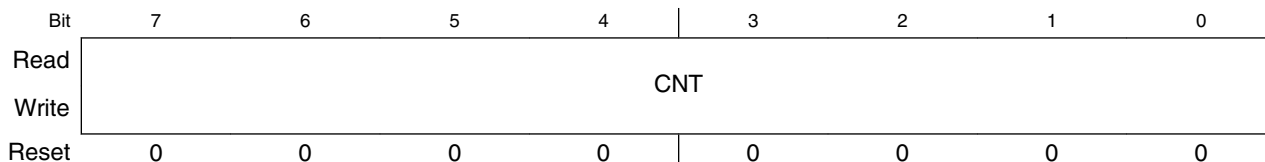

USBx_SOFTHLD field descriptions

Field	Description
7-0 CNT	This 8-bit field represents the SOF count threshold in byte times.

41.4.21 BDT Page Register 2 (USBx_BDTPAGE2)

The Buffer Descriptor Table Page Register 2 contains an 8-bit value used to compute the address where the current Buffer Descriptor Table (BDT) resides in system memory.

Addresses: USB0_BDTPAGE2 is 4007_2000h base + B0h offset = 4007_20B0h

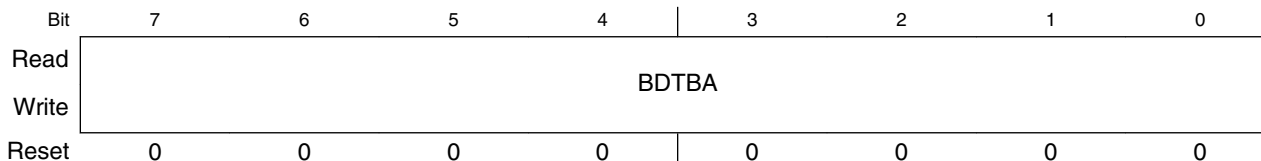

USBx_BDTPAGE2 field descriptions

Field	Description
7-0 BDTBA	This 8 bit field provides address bits 23 through 16 of the BDT base address, which defines where the Buffer Descriptor Table resides in system memory.

41.4.22 BDT Page Register 3 (USBx_BDTPAGE3)

The Buffer Descriptor Table Page Register 3 contains an 8-bit value used to compute the address where the current Buffer Descriptor Table (BDT) resides in system memory.

Addresses: USB0_BDTPAGE3 is 4007_2000h base + B4h offset = 4007_20B4h

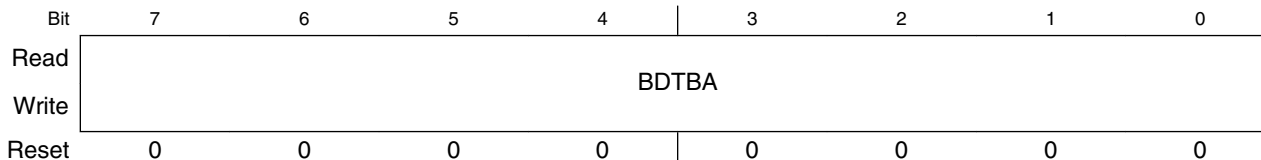

USBx_BDTPAGE3 field descriptions

Field	Description
7-0 BDTBA	This 8 bit field provides address bits 31 through 24 of the BDT base address, which defines where the Buffer Descriptor Table resides in system memory.

41.4.23 Endpoint Control Register (USBx_ENDPTn)

The Endpoint Control Registers contain the endpoint control bits for each of the 16 endpoints available within the USB Module for a decoded address. The format for these registers is shown in the following figure. Endpoint 0 (ENDPT0) is associated with control pipe 0, which is required for all USB functions. Therefore, after a USBRST interrupt occurs the processor core should set the ENDPT0 register to contain 0x0D.

In Host mode ENDPT0 is used to determine the handshake, retry and low speed characteristics of the host transfer. For Host mode control, bulk and interrupt transfers the EPHSHK bit should be set to 1. For Isochronous transfers it should be set to 0. Common values to use for ENDPT0 in host mode are 0x4D for Control, Bulk, and Interrupt transfers, and 0x4C for Isochronous transfers.

Addresses: 4007_2000h base + C0h offset + (4d × n), where n = 0d to 15d

Bit	7	6	5	4	3	2	1	0
Read	HOSTWOHUB	RETRYDIS	0	EPCTLDIS	EPRXEN	EPTXEN	EPSTALL	EPHSHK
Write								
Reset	0	0	0	0	0	0	0	0

USBx_ENDPTn field descriptions

Field	Description
7 HOSTWOHUB	This is a Host mode only bit and is only present in the control register for endpoint 0 (ENDPT0). When set this bit allows the host to communicate to a directly connected low speed device. When cleared, the host produces the PRE_PID then switch to low speed signaling when sending a token to a low speed device as required to communicate with a low speed device through a hub.
6 RETRYDIS	This is a Host mode only bit and is only present in the control register for endpoint 0 (ENDPT0). When set this bit causes the host to not retry NAK'ed (Negative Acknowledgement) transactions. When a transaction is NAKed, the BDT PID field is updated with the NAK PID, and the TOKEN_DNE interrupt is set. When this bit is cleared NAKed transactions is retried in hardware. This bit must be set when the host is attempting to poll an interrupt endpoint.
5 Reserved	This read-only field is reserved and always has the value zero.
4 EPCTLDIS	This bit, when set, disables control (SETUP) transfers. When cleared, control transfers are enabled. This applies if and only if the EPRXEN and EPTXEN bits are also set.
3 EPRXEN	This bit, when set, enables the endpoint for RX transfers.
2 EPTXEN	This bit, when set, enables the endpoint for TX transfers.
1 EPSTALL	When set this bit indicates that the endpoint is called. This bit has priority over all other control bits in the EndPoint Enable Register, but it is only valid if EPTXEN=1 or EPRXEN=1. Any access to this endpoint causes the USB Module to return a STALL handshake. After an endpoint is stalled it requires intervention from the Host Controller.
0 EPHSHK	When set this bet enables an endpoint to perform handshaking during a transaction to this endpoint. This bit is generally set unless the endpoint is Isochronous.

41.4.24 USB Control Register (USBx_USBCTRL)

Addresses: USB0_USBCTRL is 4007_2000h base + 100h offset = 4007_2100h

Bit	7	6	5	4	3	2	1	0
Read	SUSP	PDE	0					
Write								
Reset	1	1	0	0	0	0	0	0

USBx_USBCTRL field descriptions

Field	Description
7 SUSP	Places the USB transceiver into the suspend state. 0 USB transceiver is not in suspend state. 1 USB transceiver is in suspend state.
6 PDE	Enables the weak pulldowns on the USB transceiver. 0 Weak pulldowns are disabled on D+ and D- 1 Weak pulldowns are enabled on D+ and D-.
5-0 Reserved	This read-only field is reserved and always has the value zero.

41.4.25 USB OTG Observe Register (USBx_OBSERVE)

Provides visibility on the state of the pull-ups and pull-downs at the transceiver. Useful when interfacing to an external OTG control module via a serial interface.

Addresses: USB0_OBSERVE is 4007_2000h base + 104h offset = 4007_2104h

Bit	7	6	5	4	3	2	1	0
Read	DPPU	DPPD	0	DMPD	0			0
Write								
Reset	0	1	0	1	0	0	0	0

USBx_OBSERVE field descriptions

Field	Description
7 DPPU	Provides observability of the D+ Pull Up signal output from the USB OTG module. 0 D+ pullup disabled. 1 D+ pullup enabled.
6 DPPD	Provides observability of the D+ Pull Down signal output from the USB OTG module. 0 D+ pulldown disabled. 1 D+ pulldown enabled.

Table continues on the next page...

USBx_OBSERVE field descriptions (continued)

Field	Description
5 Reserved	This read-only field is reserved and always has the value zero.
4 DMPD	Provides observability of the D- Pull Down signal output from the USB OTG module. 0 D- pulldown disabled. 1 D- pulldown enabled.
3–1 Reserved	This read-only field is reserved and always has the value zero.
0 Reserved	This read-only field is reserved and always has the value zero.

41.4.26 USB OTG Control Register (USBx_CONTROL)

Addresses: USB0_CONTROL is 4007_2000h base + 108h offset = 4007_2108h

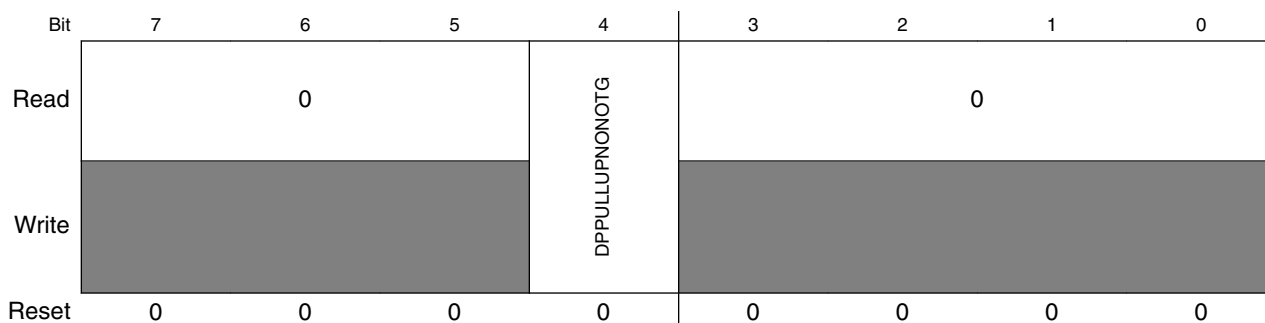

USBx_CONTROL field descriptions

Field	Description
7–5 Reserved	This read-only field is reserved and always has the value zero.
4 DPPULLUPNONOTG	Provides control of the DP PULLUP in the USB OTG module, if USB is configured in non-OTG device mode. 0 DP Pull up in non-OTG device mode is not enabled. 1 DP Pull up in non-OTG device mode is enabled.
3–0 Reserved	This read-only field is reserved and always has the value zero.

41.4.27 USB Transceiver Control Register 0 (USBx_USBTRC0)

Addresses: USB0_USBTRC0 is 4007_2000h base + 10Ch offset = 4007_210Ch

Bit	7	6	5	4	3	2	1	0
Read			USBRESMEN	0			SYNC_DET	USB_RESUME_INT
Write	USBRESET	1						
Reset	0	0	0	0	0	0	0	0

USBx_USBTRC0 field descriptions

Field	Description
7 USBRESET	<p>USB reset</p> <p>Generates a hard reset to the USB_OTG module. After this bit is set and the reset occurs, this bit is automatically cleared.</p> <p>NOTE: It is always read as zero.</p> <p>0 Normal USB module operation. 1 Returns the USB module to its reset state.</p>
6 Reserved	<p>This field is reserved.</p> <p>NOTE: Software must set this bit to 1b.</p>
5 USBRESMEN	<p>Asynchronous Resume Interrupt Enable</p> <p>This bit, when set, allows the USB module to send an asynchronous wakeup event to the MCU upon detection of resume signaling on the USB bus. The MCU then re-enables clocks to the USB module. It is used for low-power suspend mode when USB module clocks are stopped or the USB transceiver is in Suspend mode. Async wakeup only works in device mode.</p> <p>0 USB asynchronous wakeup from suspend mode disabled. 1 USB asynchronous wakeup from suspend mode enabled. The asynchronous resume interrupt differs from the synchronous resume interrupt in that it asynchronously detects K-state using the unfiltered state of the D+ and D- pins. This interrupt should only be enabled when the Transceiver is suspended.</p>
4-2 Reserved	<p>This read-only field is reserved and always has the value zero.</p>
1 SYNC_DET	<p>Synchronous USB Interrupt Detect</p> <p>0 Synchronous interrupt has not been detected. 1 Synchronous interrupt has been detected.</p>
0 USB_RESUME_INT	<p>USB Asynchronous Interrupt</p> <p>0 No interrupt was generated. 1 Interrupt was generated because of the USB asynchronous interrupt.</p>

41.5 OTG and Host Mode Operation

The Host Mode logic allows devices such as digital cameras and palmtop computers to function as a USB Host Controller. The OTG logic adds an interface to allow the OTG Host Negotiation and Session Request Protocols (HNP and SRP) to be implemented in software. Host Mode allows a peripheral such as a digital camera to be connected directly to a USB compliant printer. Digital photos can then be easily printed without having to upload them to a PC. In the palmtop computer application, a USB compliant keyboard/mouse can be connected to the palmtop computer with the obvious advantages of easier interaction.

Host mode is intended for use in handheld-portable devices to allow easy connection to simple HID class devices such as printers and keyboards. It is NOT intended to perform the functions of a full OHCI or UHCI compatible host controller found on PC motherboards. The USB-FS is not supported by Windows 98 as a USB host controller. Host mode allows bulk, Isochronous, interrupt and control transfers. Bulk data transfers are performed at nearly the full USB bus bandwidth. Support is provided for ISO transfers, but the number of ISO streams that can be practically supported is affected by the interrupt latency of the processor servicing the token during interrupts from the SIE. Custom drivers must be written to support Host mode operation.

Setting the HOST_MODE_EN bit in the CTL register enables host Mode. The USB-FS core can only operate as a peripheral device or in Host Mode. It cannot operate in both modes simultaneously. When HOST_MODE is enabled, only endpoint zero is used. All other endpoints should be disabled by software.

41.6 Host Mode Operation Examples

The following sections illustrate the steps required to perform USB host functions using the USB-FS core. While it is useful to understand the interaction of the hardware and the software at a detailed level, an understanding of the interactions at this level is not required to write host applications using the API software.

To enable host mode and discover a connected device:

1. Enable Host Mode (CTL[HOST_MODE_EN]=1). The pull-down resistors are enabled, and pull-up disabled. Start of Frame (SOF) generation begins. SOF counter loaded with 12,000. Disable SOF packet generation to eliminate noise on the USB by writing the USB enable bit to 0 (CTL[USB_EN]=0).

2. Enable the ATTACH interrupt (INT_ENB[ATTACH]=1).
3. Wait for ATTACH interrupt (INT_STAT[ATTACH]). Signaled by USB Target pull-up resistor changing the state of DPLUS or DMINUS from 0 to 1 (SE0 to J or K state).
4. Check the state of the JSTATE and SE0 bits in the control register. If the connecting device is low speed (JSTATE bit is 0), set the low-speed bit in the address registers (ADDR[LS_EN]=1) and the host without hub bit in endpoint 0 register control (EP_CTL0[HOST_WO_HUB]=1).
5. Enable RESET (CTL[RESET]=1) for 10 ms.
6. Enable SOF packet to keep the connected device from going to suspend (CTL[USB_EN=1]).
7. Start enumeration by sending a sequence of device framework commands, device framework packets to the default control pipe of the connected device. Refer to the *Universal Serial Bus Revision 2.0 specification*, "Chapter 9 USB Device Framework" (<http://www.usb.org/developers/docs>).

To complete a control transaction to a connected device:

1. Complete all steps discover a connected device
2. Set up the endpoint control register for bidirectional control transfers EP_CTL0[4:0] = 0x0d.
3. Place a copy of the device framework setup command in a memory buffer. Refer to the *Universal Serial Bus Revision 2.0 specification*, "Chapter 9 USB Device Framework" (<http://www.usb.org/developers/docs>).
4. Initialize current (even or odd) TX EP0 BDT to transfer the 8 bytes of command data for a device framework command (for example, a GET DEVICE DESCRIPTOR).
 - Set the BDT command word to 0x00080080 –Byte count to 8, own bit to 1.
 - Set the BDT buffer address field to the start address of the 8 byte command buffer.
5. Set the USB device address of the target device in the address register (ADDR[6:0]). After the USB bus reset, the device USB address is zero. It is set to some other value (usually 1) by the Set Address device framework command.
6. Write the token register with a SETUP to Endpoint 0 the target device default control pipe (TOKEN=0xD0). This initiates a setup token on the bus followed by a data packet. The device handshake is returned in the BDT PID field after the packets

complete. When the BDT is written a token done (INT_STAT[TOK_DNE]) interrupt is asserted. This completes the setup phase of the setup transaction. Refer to the *Universal Serial Bus Revision 2.0 specification*, "Chapter 9 USB Device Framework" (<http://www.usb.org/developers/docs>).

7. To initiate the data phase of the setup transaction (for example, get the data for the GET DEVICE descriptor command) set up a buffer in memory for the data to be transferred.
8. Initialize the current (even or odd) TX EP0 BDT to transfer the data.
 - Set the BDT command word to 0x004000C0 –Byte count to the length of the data buffer in this case 64, own bit to 1, Data toggle to Data1.
 - Set the BDT buffer address field to the start address of the data buffer
9. Write the token register with a IN or OUT token to Endpoint 0 the target device default control pipe, an IN token for a GET DEVICE DESCRIPTOR command (TOKEN=0x90). This initiates an IN token on the bus followed by a data packet from the device to the host. When the data packet completes the BDT is written and a token done (INT_STAT[TOK_DNE]) interrupt is asserted. For control transfers with a single packet data phase this completes the data phase of the setup transaction. Refer to the *Universal Serial Bus Revision 2.0 specification*, "Chapter 9 USB Device Framework" (<http://www.usb.org/developers/docs>).
10. To initiate the Status phase of the setup transaction set up a buffer in memory to receive or send the zero length status phase data packet.
11. Initialize the current (even or odd) TX EP0 BDT to transfer the status data.
 - Set the BDT command word to 0x00000080 –Byte count to the length of the data buffer in this case 0, own bit to 1, Data toggle to Data0.
 - Set the BDT buffer address field to the start address of the data buffer
12. Write the token register with a IN or OUT token to Endpoint 0 the target device default control pipe, an OUT token for a GET DEVICE DESCRIPTOR command (TOKEN=0x10). This initiates an OUT token on the bus followed by a zero length data packet from the host to the device. When the data packet completes the BDT is written with the handshake form the device and a token done (INT_STAT[TOK_DNE]) interrupt is asserted. This completes the data phase of the setup transaction. Refer to the *Universal Serial Bus Revision 2.0 specification*, "Chapter 9 USB Device Framework" (<http://www.usb.org/developers/docs>).

To send a Full speed bulk data transfer to a target device:

1. Complete all steps discover a connected device and to configure a connected device. Write the ADDR register with the address of the target device. Typically, there is only one other device on the USB bus in host mode so it is expected that the address is 0x01 and should remain constant.
2. Write the ENDPT0 to 0x1D register to enable transmit and receive transfers with handshaking enabled.
3. Setup the Even TX EP0 BDT to transfer up to 64 bytes.
4. Set the USB device address of the target device in the address register (ADDR[6:0]).
5. Write the TOKEN register with an OUT token to the desired endpoint. The write to this register triggers the USB-FS transmit state machines to begin transmitting the TOKEN and the data.
6. Setup the Odd TX EP0 BDT to transfer up to 64 bytes.
7. Write the TOKEN register with an OUT token as in step 4. Two Tokens can be queued at a time to allow the packets to be double buffered to achieve maximum throughput.
8. Wait for the TOK_DNE interrupt. This indicates one of the BDTs has been released back to the microprocessor and that the transfer has completed. If the target device asserts NAKs, the USB-FS continues to retry the transfer indefinitely without processor intervention unless the RETRY_DIS retry disable bit is set in the EP0 control register. If the retry disable bit is set, the handshake (ACK, NAK, STALL, or ERROR (0xf)) is returned in the BDT PID field. If a stall interrupt occurs, the pending packet must be dequeued and the error condition in the target device cleared. If a RESET interrupt occurs (SE0 for more than 2.5us), the target has detached.
9. After the TOK_DNE interrupt occurs, the BDTs can be examined and the next data packet queued by returning to step 2.

41.7 On-The-Go Operation

The USB-OTG core provides sensors and controls to enable On-The-Go (OTG) operation. These sensors are used by the OTG API software to implement the Host Negotiation Protocol (HNP) and Session Request Protocol (SRP). API calls are provided to give access the OTG protocol control signals, and include the OTG capabilities in the device application. The following state machines show the OTG operations involved with HNP and SRP protocols from either end of the USB cable.

41.7.1 OTG Dual Role A Device Operation

A device is considered the A device because of the type of cable attached. If the USB Type A connector or the USB Type Mini A connector is plugged into the device, he is considered the A device.

A dual role A device operates as the following flow diagram and state description table illustrates.

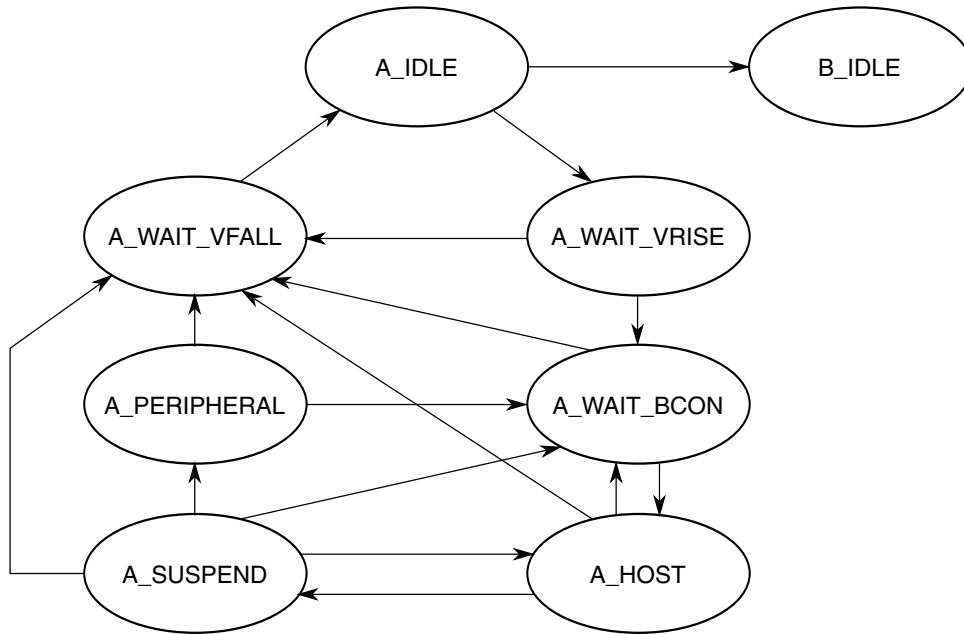

Figure 41-91. Dual Role A Device Flow Diagram

Table 41-94. State Descriptions for the Dual Role A Device Flow

State	Action	Response
A_IDLE	If ID Interrupt. The cable has been un-plugged or a Type B cable has been attached. The device now acts as a Type B device.	Go to B_IDLE
	If the A application wants to use the bus or if the B device is doing an SRP as indicated by an A_SESS_VLD Interrupt or Attach or Port Status Change Interrupt check data line for 5 –10 msec pulsing.	Go to A_WAIT_VRISE Turn on DRV_VBUS
A_WAIT_VRISE	If ID Interrupt or if A_VBUS_VLD is false after 100 msec The cable has been changed or the A device cannot support the current required from the B device.	Go to A_WAIT_VFALL Turn off DRV_VBUS
	If A_VBUS_VLD interrupt	Go to A_WAIT_BCON

Table continues on the next page...

Table 41-94. State Descriptions for the Dual Role A Device Flow (continued)

State	Action	Response
A_WAIT_BCON	After 200 msec without Attach or ID Interrupt. (This could wait forever if desired.)	Go to A_WAIT_FALL Turn off DRV_VBUS
	A_VBUS_VLD Interrupt and B device attaches	Go to A_HOST Turn on Host Mode
A_HOST	Enumerate Device determine OTG Support.	
	If A_VBUS_VLD/ Interrupt or A device is done and doesn't think he wants to do something soon or the B device disconnects	Go to A_WAIT_VFALL Turn off Host Mode Turn off DRV_VBUS
	If the A device is finished with session or if the A device wants to allow the B device to take bus.	Go to A_SUSPEND
	ID Interrupt or the B device disconnects	Go to A_WAIT_BCON
A_SUSPEND	If ID Interrupt, or if 150 msec B disconnect timeout (This timeout value could be longer) or if A_VBUS_VLD\ Interrupt	Go to A_WAIT_VFALL Turn off DRV_VBUS
	If HNP enabled, and B disconnects in 150 msec then B device is becoming the host.	Go to A_PERIPHERAL Turn off Host Mode
	If A wants to start another session	Go to A_HOST
A_PERIPHERAL	If ID Interrupt or if A_VBUS_VLD interrupt	Go to A_WAIT_VFALL Turn off DRV_VBUS.
	If 3 –200 msec of Bus Idle	Go to A_WAIT_BCON Turn on Host Mode
A_WAIT_VFALL	If ID Interrupt or (A_SESS_VLD/ & b_conn/)	Go to A_IDLE

41.7.2 OTG Dual Role B Device Operation

A device is considered a B device if it connected to the bus with a USB Type B cable or a USB Type Mini B cable.

A dual role B device operates as the following flow diagram and state description table illustrates.

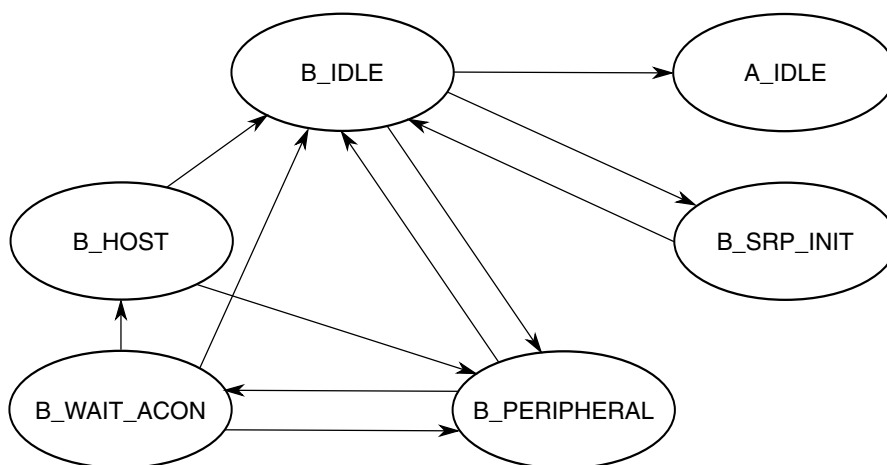

Figure 41-92. Dual Role B Device Flow Diagram

Table 41-95. State Descriptions for the Dual Role B Device Flow

State	Action	Response
B_IDLE	If ID\ Interrupt. A Type A cable has been plugged in and the device should now respond as a Type A device.	Go to A_IDLE
	If B_SESS_VLD Interrupt. The A device has turned on VBUS and begins a session.	Go to B_PERIPHERAL Turn on DP_HIGH
	If B application wants the bus and Bus is Idle for 2 ms and the B_SESS_END bit is set, the B device can perform an SRP.	Go to B_SRP_INIT Pulse CHRG_VBUS Pulse DP_HIGH 5-10 ms
B_SRP_INIT	If ID\ Interrupt or SRP Done (SRP must be done in less than 100 msecs.)	Go to B_IDLE
B_PERIPHERAL	If HNP enabled and the bus is suspended and B wants the bus, the B device can become the host.	Go to B_WAIT_ACON Turn off DP_HIGH
B_WAIT_ACON	If A connects, an attach interrupt is received	Go to B_HOST Turn on Host Mode
	If ID\ Interrupt or B_SESS_VLD/ Interrupt If the cable changes or if VBUS goes away, the host doesn't support us. Go to B_IDLE	Go to B_IDLE
	If 3.125 ms expires or if a Resume occurs	Go to B_PERIPHERAL
B_HOST	If ID\ Interrupt or B_SESS_VLD\ Interrupt If the cable changes or if VBUS goes away, the host doesn't support us.	Go to B_IDLE
	If B application is done or A disconnects	Go to B_PERIPHERAL



Chapter 42

USB Device Charger Detection Module (USBDCD)

42.1 Preface

42.1.1 References

The following publications are referenced in this document. For updates to these specifications, see <http://www.usb.org>.

- *USB Battery Charging Specification Revision 1.1, USB Implementers Forum*
- *Universal Serial Bus Specification Revision 2.0, USB Implementers Forum*

42.1.2 Acronyms and Abbreviations

The following table contains acronyms and abbreviations used in this document.

Table 42-1. Acronyms and Abbreviated Terms

Term	Meaning
FS	Full Speed (12 Mbps)
HS	High Speed (480 Mbps)
I _{DEV_DCHG}	Current drawn when the USB device is connected to a dedicated charging port
I _{DEV_HCHG_LFS}	Current drawn when the USB device is connected to an FS charging host port
I _{DM_SINK}	Current sink for the D- line
I _{DP_SRC}	Current source for the D+ line
I _{SUSP}	Current drawn when the USB device is suspended
LDO	Low dropout
LS	Low Speed (1.5 Mbps)
N/A	Not applicable

Table continues on the next page...

Table 42-1. Acronyms and Abbreviated Terms (continued)

Term	Meaning
OTG	On-The-Go
R _{DM_DWN}	D- pulldown resistance for data pin contact detect
V _{DAT_REF}	Data detect reference voltage for the voltage comparator
V _{DP_SRC}	Voltage source for the D+ line
V _{LGC}	Threshold voltage for logic high

42.1.3 Glossary

The following table shows a glossary of terms used in this document.

Table 42-2. Glossary of Terms

Term	Definition
Transceiver	Module that implements the physical layer of the USB standard (FS or LS only)
PHY	Module that implements the physical layer of the USB standard (HS capable)
Attached	Device is physically plugged into USB port but has <i>not enabled</i> either D+ or D- pullup resistor
Connected	Device is physically plugged into USB port and has <i>enabled</i> either D+ or D- pullup resistor
Suspended	After 3 ms of no bus activity the USB device enters suspend mode.
Component	The hardware and software that make up a subsystem.

42.2 Introduction

NOTE

For the chip-specific implementation details of this module's instances see the chip configuration chapter.

The USBDCD module works with the USB transceiver to detect if the USB device is attached to a charging port (either a dedicated charging port or a charging host). System software coordinates the detection activities of the module and controls an off-chip integrated circuit that performs the battery charging.

42.2.1 Block Diagram

The following figure is a high level block diagram of the module.

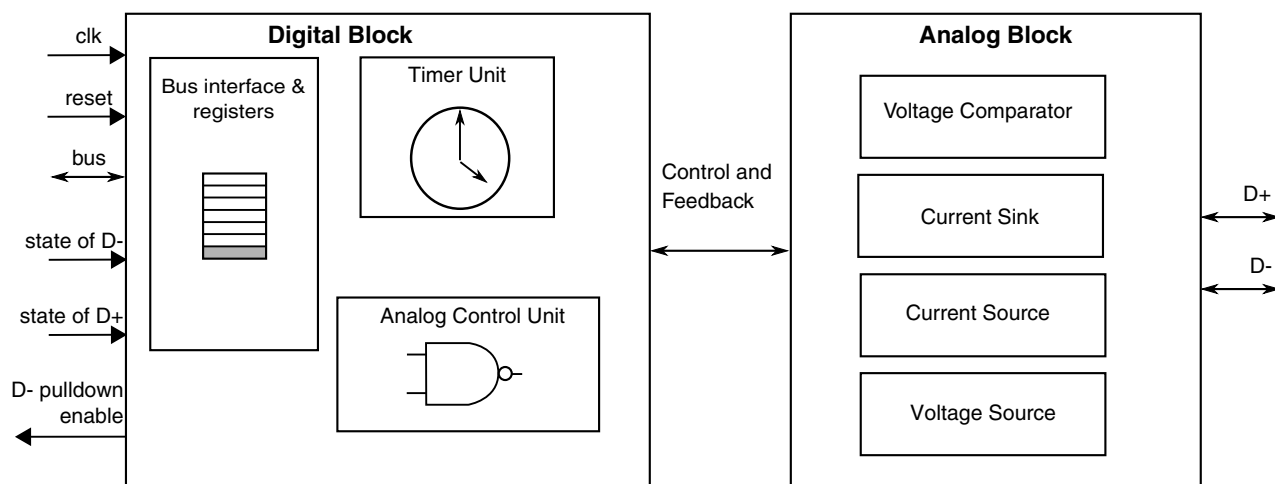

Figure 42-1. Block Diagram

The USBDCD module consists of 2 main blocks:

- A digital block provides the programming interface (memory-mapped registers) and includes the timer unit and the analog control unit.
- An analog block provides the circuitry for the physical detection of the charger, including the voltage source, current source, current sink, and voltage comparator circuitry.

42.2.2 Features

The USBDCD module offers the following features:

- Compliant with the latest industry standard specification: *USB Battery Charging Specification, Revision 1.1*
- Programmable timing parameters default to values required by the industry standards:
 - Having standard default values allows for minimal configuration: Set the clock frequency before enabling the module.
 - Programmability allows for flexibility to meet future updates to the standards.

42.2.3 Modes of Operation

The USBDCD module operating modes are shown in the following table.

Table 42-3. Module Modes and Their Conditions

Module Mode	Description	Conditions When Used
Enabled	The module performs the charger detection sequence.	System software should enable the module only when <i>all</i> of the following conditions are true: <ul style="list-style-type: none"> • The system uses a rechargeable battery. • The device is being used in an FS USB device application. • The device has detected that it is attached to the USB cable.
Disabled	The module is not active and is held in a low power state.	System software should disable the module when <i>either</i> of the following conditions is true: <ul style="list-style-type: none"> • The charger detect sequence is complete. • The conditions for being enabled are not met.
Powered Off	The digital supply voltage dvdd is removed. Optionally, the analog supply voltage avdd33 also may be reduced to as low as 1.7v without causing excess leakage.	Low system performance requirements allow putting the device into a very low-power stop mode.

Operating mode transitions are shown in the following table.

Table 42-4. Entering and Exiting Module Modes

Module Mode	Entering	Exiting	Mode after Exiting
Enabled	Set the CONTROL[START] bit.	Set the CONTROL[SR] bit. ¹	Disabled
Disabled	Take <i>either</i> of the following actions: <ul style="list-style-type: none"> • Set the CONTROL[SR] bit.¹ • Reset the module. (The module is disabled out of reset by default.) 	Set the CONTROL[START] bit.	Enabled
Powered Off	Perform the following actions: <ol style="list-style-type: none"> 1. Put the device into very low-power stop mode. 2. Adjust the supply voltages. 	Perform the following actions: <ol style="list-style-type: none"> 1. Restore the supply voltages. 2. Take the device out of very low-power stop mode. 	Disabled

1. The effect of setting the SR bit is immediate; that is, the module is disabled even if the sequence has not completed.

42.3 Module Signal Description

This section describes the module signals.

42.3.1 USB Signal Descriptions

The following table shows a summary of module signals that interface with the device's pins.

Table 42-5. USB Signal Descriptions

Signal	Description	I/O
usb_dm	USB D- analog data signal. The analog block interfaces directly to the D- signal on the USB bus.	I/O
usb_dp	USB D+ analog data signal. The analog block interfaces directly to the D+ signal on the USB bus.	I/O
avdd33 ¹	3.3v regulated analog supply	I
avss	Analog ground	I
dvss	Digital ground	I
dvdd	1.2 V digital supply	I

1. Voltage must be 3.3v +/- 10% for full functionality of the module. That is, the charger detection function does not work when this voltage is below 3.0v, and the CONTROL[START] bit should not be set.

NOTE

The transceiver module also interfaces to usb_dm and usb_dp. Both modules and the USB host/hub use these signal as bi-directional, tri-state signals.

Information about the signal integrity aspects of the lines including shielding, isolated return paths, input or output impedance, packaging, suggested external components, ESD, and other protections can be found in the USB 2.0 specification and in [Application Information](#).

42.4 Memory Map/Register Definition

This section describes the memory map and registers for the USBDCD module.

USBDCD memory map

Absolute address (hex)	Register name	Width (in bits)	Access	Reset value	Section/page
4003_5000	USBDCD_CONTROL	32	R/W	0001_0000h	42.4.1/1042
4003_5004	Clock Register (USBDCD_CLOCK)	32	R/W	0000_00C1h	42.4.2/1043

Table continues on the next page...

USBDCD memory map (continued)

Absolute address (hex)	Register name	Width (in bits)	Access	Reset value	Section/page
4003_5008	Status Register (USBDCD_STATUS)	32	R	0000_0000h	42.4.3/ 1044
4003_5010	TIMER0 Register (USBDCD_TIMER0)	32	R/W	0010_0000h	42.4.4/ 1046
4003_5014	USBDCD_TIMER1	32	R/W	000A_0028h	42.4.5/ 1047
4003_5018	USBDCD_TIMER2	32	R/W	0028_0001h	42.4.6/ 1047

42.4.1 Control Register (USBDCD_CONTROL)

Contains the control and interrupt bit fields.

Address: USBDCD_CONTROL is 4003_5000h base + 0h offset = 4003_5000h

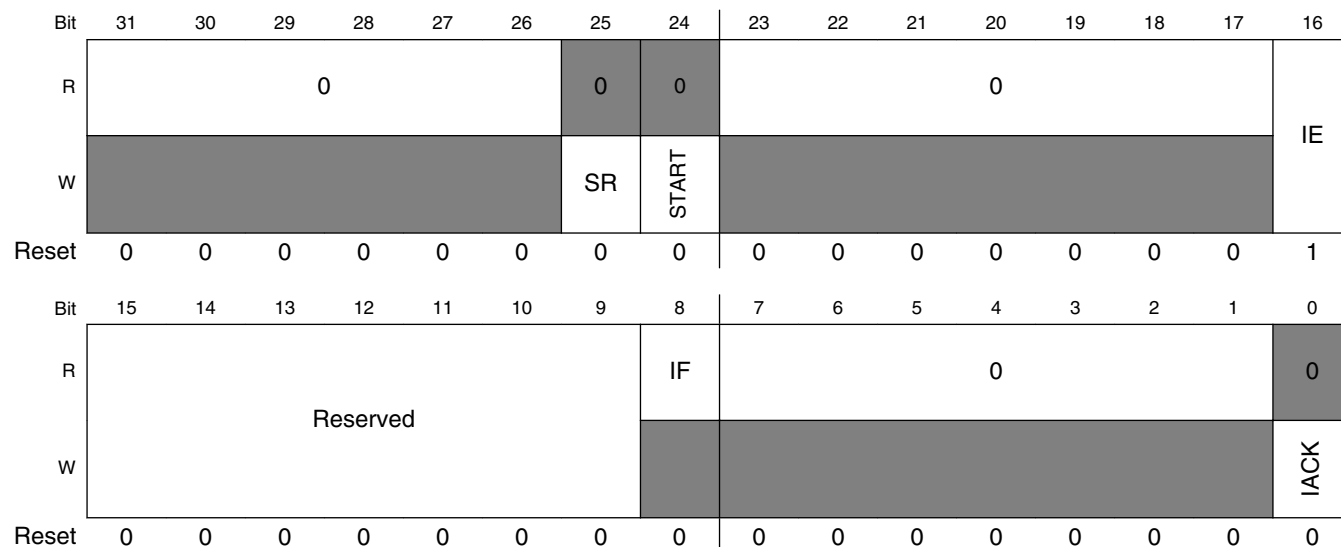

USBDCD_CONTROL field descriptions

Field	Description
31–26 Reserved	This read-only field is reserved and always has the value zero.
25 SR	Software Reset Determines whether a software reset is performed. 0 Do not perform a software reset. 1 Perform a software reset.
24 START	Start Change Detection Sequence

Table continues on the next page...

USBDCD_CONTROL field descriptions (continued)

Field	Description
	<p>Determines whether the charger detection sequence is initiated.</p> <p>0b0 Do not start the sequence. Writes of this value have no effect. 0b1 Initiate the charger detection sequence. If the sequence is already running, writes of this value have no effect.</p>
23–17 Reserved	This read-only field is reserved and always has the value zero.
16 IE	<p>Interrupt Enable</p> <p>Enables/disables interrupts to the system.</p> <p>0b0 Disable interrupts to the system. 0b1 Enable interrupts to the system.</p>
15–9 Reserved	This field is reserved.
8 IF	<p>Interrupt Flag</p> <p>Determines whether an interrupt is pending</p> <p>0b0 No interrupt is pending. 0b1 An interrupt is pending.</p>
7–1 Reserved	This read-only field is reserved and always has the value zero.
0 IACK	<p>Interrupt Acknowledge</p> <p>Determines whether the interrupt is cleared.</p> <p>0b0 Do not clear the interrupt. 0b1 Clear the IF bit (interrupt flag).</p>

42.4.2 Clock Register (USBDCD_CLOCK)

Address: USBDCD_CLOCK is 4003_5000h base + 4h offset = 4003_5004h

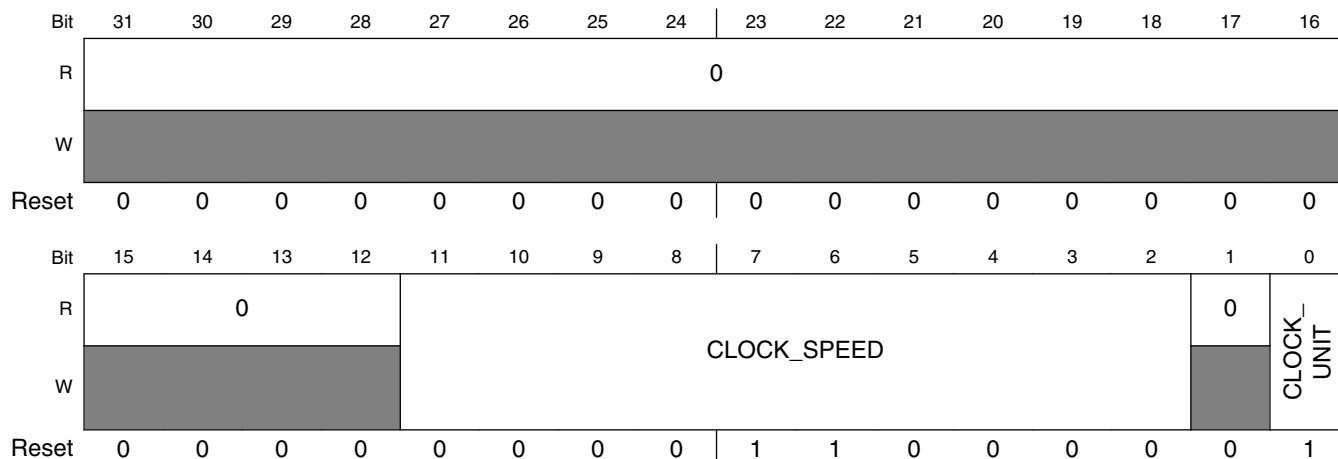

USBDCD_CLOCK field descriptions

Field	Description
31–12 Reserved	This read-only field is reserved and always has the value zero.
11–2 CLOCK_SPEED	<p>Numerical Value of Clock Speed in Binary</p> <p>The unit of measure is programmed in CLOCK_UNIT. The valid range is from 1 to 1023 when clock unit is MHz and 4 to 1023 when clock unit is KHz. Examples with CLOCK_UNIT = 1:</p> <ul style="list-style-type: none"> For 48 MHz: 0b00_0011_0000 (48) (Default) For 24 MHz: 0b00_0001_1000 (24) <p>Examples with CLOCK_UNIT = 0:</p> <ul style="list-style-type: none"> For 100 kHz: 0b00_0110_0100 (100) For 500 kHz: 0b01_1111_0100 (500)
1 Reserved	This read-only field is reserved and always has the value zero.
0 CLOCK_UNIT	<p>Unit of measurement encoding for Clock Speed</p> <p>Specifies the unit of measure for the clock speed.</p> <p>0b0 kHz Speed (between 1 kHz and 1023 kHz) 0b1 MHz Speed (between 1 MHz and 1023 MHz)</p>

42.4.3 Status Register (USBDCD_STATUS)

The status register provides the current state of the module for system software monitoring.

Address: USBDCD_STATUS is 4003_5000h base + 8h offset = 4003_5008h

Bit	31	30	29	28	27	26	25	24	23	22	21	20	19	18	17	16
R	0								ACTIVE	TO	ERR	SEQ_STAT	SEQ_RES			
W	[Shaded]															
Reset	0	0	0	0	0	0	0	0	0	0	0	0	0	0	0	0
Bit	15	14	13	12	11	10	9	8	7	6	5	4	3	2	1	0
R	Reserved															
W	[Shaded]															
Reset	0	0	0	0	0	0	0	0	0	0	0	0	0	0	0	0

USBDCD_STATUS field descriptions

Field	Description
31–23 Reserved	This read-only field is reserved and always has the value zero.
22 ACTIVE	<p>Active Status Indicator</p> <p>Indicates whether the sequence is running.</p> <p>0b0 The sequence is not running. 0b1 The sequence is running.</p>
21 TO	<p>Timeout Flag</p> <p>Indicates whether the detection sequence has passed the timeout threshold.</p> <p>0b0 The detection sequence has not been running for over 1 s. 0b1 It has been over 1 s since the data pin contact was detected and debounced.{</p>
20 ERR	<p>Error Flag</p> <p>Indicates whether there is an error in the detection sequence.</p> <p>0b0 No sequence errors. 0b1 Error in the detection sequence. See the SEQ_STAT field to determine the phase in which the error occurred.</p>
19–18 SEQ_STAT	<p>Charger Detection Sequence Status</p> <p>Indicates the status of the charger detection sequence.</p> <p>0b00 The module is either not enabled, or the module is enabled but the data pins have not yet been detected. 0b01 Data pin contact detection is complete. 0b10 Charger detection is complete. 0b11 Charger type detection is complete.</p>
17–16 SEQ_RES	<p>Charger Detection Sequence Results</p> <p>Reports how charger detection is attached.</p> <p>0b00 No results to report. 0b01 Attached to a standard host. Must comply with USB Spec 2.0 by drawing only 2.5mA (max) until connected. 0b10 Attached to a charging port. The exact meaning depends on bit 18: 0: Attached to either a charging host or a dedicated charger (The charger type detection has not completed.) 1: Attached to a charging host (The charger type detection has completed.) 0b11 Attached to a dedicated charger.</p>
15–0 Reserved	<p>This field is reserved.</p> <p>NOTE: Bits do not always read as 0.</p>

42.4.4 TIMER0 Register (USBDCD_TIMER0)

TIMER0 has an TSEQ_INIT field that represents the system latency (in ms) measured from the time VBUS goes active to the time system software initiates the charger detection sequence in the USBDCD module. When software sets the CONTROL[START] bit, the Unit Connection Timer (TUNITCON) is initialized with the value of TSEQ_INIT. Valid values are 0-1023, however the USB Battery Charging Specification requires the entire sequence, including TSEQ_INIT, to be completed in 1s or less.

Address: USBDCD_TIMER0 is 4003_5000h base + 10h offset = 4003_5010h

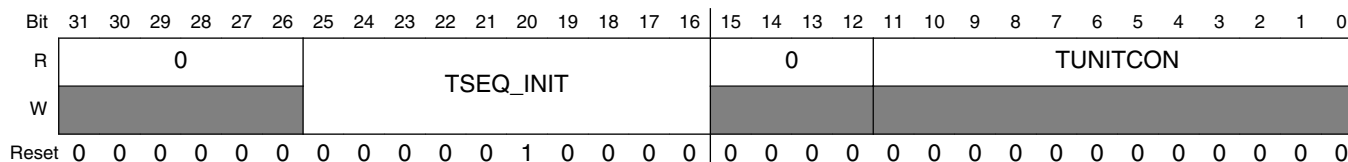

USBDCD_TIMER0 field descriptions

Field	Description
31–26 Reserved	This read-only field is reserved and always has the value zero.
25–16 TSEQ_INIT	Sequence Initiation Time TSEQ_INIT represents the system latency (in ms) measured from the time VBUS goes active to the time system software initiates the charger detection sequence in the USBDCD module. When software sets the CONTROL[START] bit, the Unit Connection Timer (TUNITCON) is initialized with the value of TSEQ_INIT. Valid values are 0-1023, but the USB Battery Charging Specification requires the entire sequence, including TSEQ_INIT, to be completed in 1s or less.
15–12 Reserved	This read-only field is reserved and always has the value zero.
11–0 TUNITCON	Unit Connection Timer Elapse (in ms) Displays the current elapsed time since software set the CONTROL[START] bit plus the value of TSEQ_INIT. The timer is initially loaded with the value of TSEQ_INIT before starting to count. This timer enables compliance with the maximum time allowed to connect (TUNIT_CON) under the USB Battery Charging Specification, v1.1.If the timer reaches the TUNIT_CON one second limit, the module triggers an interrupt and sets the error flag STATUS[ERR]. The timer continues counting throughout the charger detection sequence, even when control has been passed to software. As long as the module is active, the timer continues to count until it reaches the maximum value of 0xFFF (4095 ms). The timer does not rollover to zero. A software reset clears the timer.

42.4.5 USBDCD_TIMER1

Address: USBDCD_TIMER1 is 4003_5000h base + 14h offset = 4003_5014h

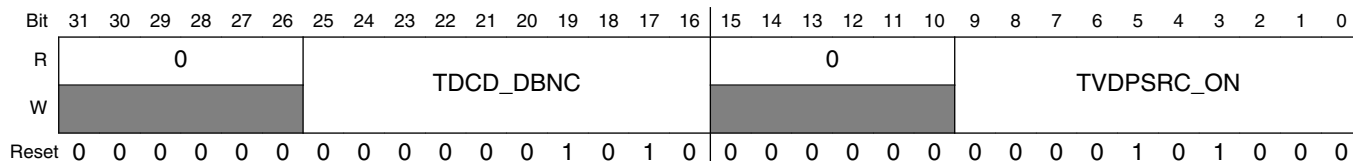

USBDCD_TIMER1 field descriptions

Field	Description
31–26 Reserved	This read-only field is reserved and always has the value zero.
25–16 TDCD_DBNC	Time Period to Debounce D+ Signal Sets the amount of time (in ms) to debounce the D+ signal during the data pin contact detection phase (while IDP_SRC and RDM_DWN are enabled). Valid values are 1-1023, but the USB Battery Charging Specification requires a minimum value of 10 ms.
15–10 Reserved	This read-only field is reserved and always has the value zero.
9–0 TVDPSRC_ON	Time Period Comparator Enabled Sets the amount of time (in ms) that VDP_SRC, IDM_SINK, and the D-/VDAT_REF comparator are enabled and connected to the D+/D- lines during the charging port detection phase of the sequence. Valid values are 1-1023, but the USB Battery Charging Specification requires a minimum value of 40 ms.

42.4.6 USBDCD_TIMER2

TIMER2 contains timing parameters. Note that register values can be written that are not compliant with the USB Battery Charging Specification v1.1, so care should be taken when overwriting the default values.

Address: USBDCD_TIMER2 is 4003_5000h base + 18h offset = 4003_5018h

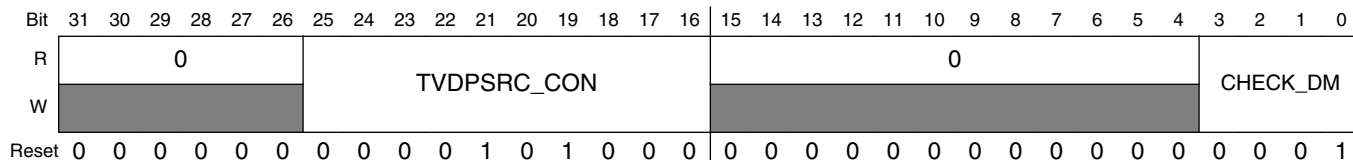

USBDCD_TIMER2 field descriptions

Field	Description
31–26 Reserved	This read-only field is reserved and always has the value zero.

Table continues on the next page...

USBDCD_TIMER2 field descriptions (continued)

Field	Description
25–16 TVDP_SRC_CON	Time Period Before Enabling D+ Pullup Sets the amount of time (in ms) that the module waits after charging port detection before system software should enable the D+ pullup to connect to the USB host. Valid values are 1-1023, but the USB Battery Charging Specification requires a minimum value of 40 ms.
15–4 Reserved	This read-only field is reserved and always has the value zero.
3–0 CHECK_DM	Time Before Check of D- Line Sets the amount of time (in ms) that the module waits after the device connects to the USB bus (software enables the D+ pullup) until checking the state of the D- line to determine the type of charging port. Valid values are 1-15ms.

42.5 Functional Description

The sequence of detecting the presence of and type of charging port involves several hardware components, coordinated by system software. This collection of interacting hardware and software is called the USB Battery Charging Subsystem. The following figure shows the USBDCD module as a component of the subsystem. The following table describes the components.

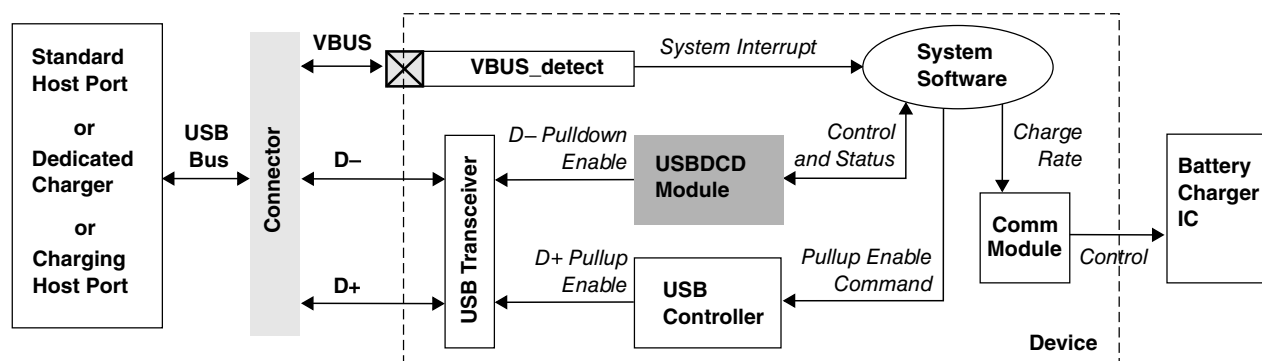

Figure 42-8. The USB Battery Charging Subsystem

Table 42-13. USB Battery Charger Subsystem Components

Component	Description								
Battery Charger IC	The external battery charger IC regulates the charge rate to the rechargeable battery. System software is responsible for communicating the appropriate charge rates.								
	<table border="1"> <thead> <tr> <th>Charger</th> <th>Maximum Current Drawn¹</th> </tr> </thead> <tbody> <tr> <td>Standard host port</td> <td>up to 500 mA</td> </tr> <tr> <td>Charging host port</td> <td>up to 1500 mA</td> </tr> <tr> <td>Dedicated charging port</td> <td>up to 1800 mA</td> </tr> </tbody> </table>	Charger	Maximum Current Drawn ¹	Standard host port	up to 500 mA	Charging host port	up to 1500 mA	Dedicated charging port	up to 1800 mA
	Charger	Maximum Current Drawn ¹							
	Standard host port	up to 500 mA							
Charging host port	up to 1500 mA								
Dedicated charging port	up to 1800 mA								
1. If the USB host has suspended the USB device, system software must configure the system to limit the current drawn from the USB bus to 2.5 mA or less.									
Comm Module	A communications module on the device can be used to control the charge rate of the battery charger IC.								
System software	Coordinates the detection activities of the subsystem.								
USB Controller	<p>The D+ pullup enable control signal plays a role during the charger type detection phase. System software must issue a command to the USB controller to assert this signal. Once this pullup is enabled, the device is considered to be connected to the USB bus. The host then attempts to enumerate it.</p> <p>Note that the USB controller must be used only for USB <i>device</i> applications when using the USBDCD module. For USB <i>host</i> applications the USBDCD module must be disabled.</p>								
USB Transceiver	<p>The USB transceiver contains the pullup resistor for the USB D+ signal and the pulldown resistors for the USB D+ and D- signals. The D+ pullup and the D- pulldown are both used during the charger detection sequence. The USB transceiver also outputs the digital state of the D+ and D- signals from the USB bus.</p> <p>The pullup and pulldown enable signals are controlled by other modules during the charger detection sequence: The D+ pullup enable is physically output from the USB controller but is under software control. The USBDCD module controls the D- pulldown enable.</p>								
USBDCD Module	Detects if the device has been plugged into either a standard host port, a charging host port, or a dedicated charger.								
VBUS_detect	This interrupt pin connected to the USB VBUS signal detects when the device has been plugged into or unplugged from the USB bus. If the system requires waking up from a low power mode upon being plugged into the USB port, this interrupt should also be a low power wake up source. If this pin multiplexes other functions, such as GPIO, the pin should be configured as an interrupt whenever the USB plug or unplug event is required to be detected.								

1. If the USB host has suspended the USB device, system software must configure the system to limit the current drawn from the USB bus to 2.5 mA or less.

42.5.1 The Charger Detection Sequence

The following figure illustrates the charger detection sequence in a simplified timing diagram based on the USB Battery Charging Specification v1.1.

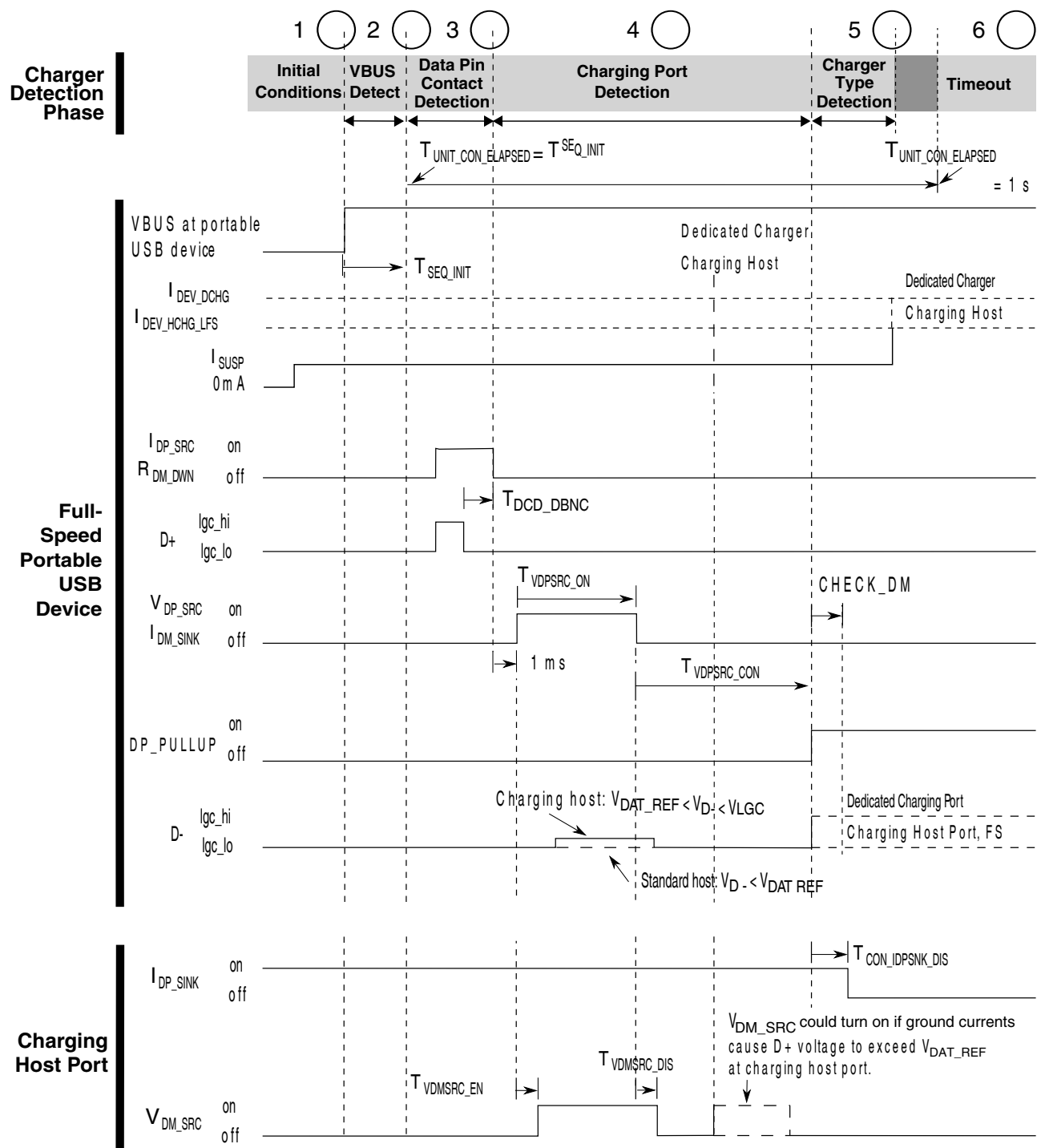

Figure 42-9. Full Speed Charger Detection Timing

The following table provides an overview description of the charger detection sequence shown in the preceding figure.

Table 42-14. Overview of the Charger Detection Sequence

Phase		Overview Description	Full Description
1	Initial Conditions	Initial system conditions that need to be met before initiating the detection sequence	Initial System Conditions
2	VBUS Detection	System software detects contact of the VBUS signal with the system interrupt pin VBUS_detect.	VBUS Contact Detection
3	Data Pin Contact Detection	The USBDCD module detects that the USB data pins D+ and D- have made contact with the USB port.	Data Pin Contact Detection
4	Charging Port Detection	The USBDCD module detects if the port is a standard host or either type of charging port (charging host or dedicated charger).	Charging Port Detection
5	Charger Type Detection	If attached to a charging port, detect which type.	Charger Type Detection
6	Sequence Timeout	The USBDCD module did not finish the detection sequence within the timeout interval. The sequence will continue until halted by software.	Charger Detection Sequence Timeout

Timing parameter values used in this module are listed in the following table.

Table 42-15. Timing Parameters for the Charger Detection Sequence

Parameter	USB Battery Charging Spec	Module Default	Module Programmable Range
$T_{DCD_DBNC}^1$	10 ms min (no max)	10 ms	0 - 1023 ms
$T_{VDPSRC_ON}^1$	40 ms min (no max)	40 ms	0 - 1023 ms
$T_{VDPSRC_CON}^1$	40 ms min (no max)	40 ms	0 - 1023 ms
CHECK_DM	N/A	1 ms	0 - 15 ms
T_{SEQ_INIT}	N/A	16 ms	0 - 1023 ms
$T_{UNIT_CON}^1$	1 s	N/A	N/A
$T_{VDMSRC_EN}^1$	1 - 20 ms	From the USB host	N/A
$T_{VDMSRC_DIS}^1$	0 - 20 ms	From the USB host	N/A
$T_{CON_IDPSINK_DIS}^1$	0 - 20 ms	From the USB host	N/A

1. This parameter is defined by the *USB Battery Charging Specification, v1.1*.

42.5.1.1 Initial System Conditions

Before starting the USBDCD module's charger detection sequence, the system must be:

- using a rechargeable battery,
- for a FS USB *device* application (cannot be HS, LS, host, or OTG),
- powered-up and in run mode,

- recently plugged into a USB port, and
- drawing no more than 2.5 mA total system current from the USB bus.

There are many allowable precursors to this set of initial conditions. For example, the device could have been powered down and subsequently powered up upon being plugged into the USB bus. Alternatively, the device could have been in a low power state that was exited due to the plugin event. Or, the device could have been operating in normal run mode, powered by a separate supply or non-rechargeable battery.

42.5.1.2 VBUS Contact Detection

Once the device is plugged into a USB port, the VBUS_detect system interrupt is triggered. System software should do the following to initialize the module and start the charger detection sequence:

1. Restore power if the module is powered-off.
2. Set the CONTROL[SR] bit to initiate a software reset.
3. Configure the USBDCD module: Program the CLOCK register and the timing parameters as needed.
4. Set the CONTROL[IE] bit to enable interrupts (by default), or clear the bit if using a software polling method.
5. Set the CONTROL[START] bit to start the charger detection sequence.

42.5.1.3 Data Pin Contact Detection

Because the detection sequence depends upon the state of the USB D+, the module must ensure that the data pins have made contact. USB plugs and receptables are designed such that when the plug is inserted into the receptable, the power pins make contact before the data pins make contact. See the following figure.

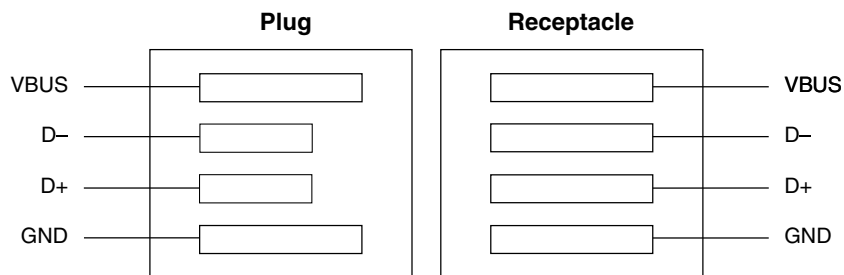

Figure 42-10. Relative Pin Positions in USB Plugs and Receptacles

As a result, when a portable USB device is attached to an upstream port, the portable USB device detects VBUS before the data pins have made contact. The time between power pins and data pins making contact depends on how fast the plug is inserted into the receptacle. Delays of several hundred milliseconds are possible.

42.5.1.3.1 Debouncing the Data Pin Contact

When system software has initiated the charger detection sequence, as described in [Initial System Conditions](#) the USBDCD module turns on the I_{DP_SRC} current source and enables the R_{DM_DWN} pulldown resistor. If the data pins have not made contact, the D+ line remains high. Once the data pins make contact, the D+ line goes low and debouncing begins.

Once the D+ line goes low, the module continuously samples the D+ line over the duration of the T_{DCD_DBNC} debounce time interval. T_{DCD_DBNC} defaults to 10 ms but can be programmed in the `TIMER0[TDCD_DBNC]` field. See the description of the `TIMER0` Register for register information.

When it has remained low for the entire interval, the debouncing is complete. However, if the D+ line returns high during the debounce interval, the module waits until the D+ line goes low again to restart the debouncing. This cycle repeats until either:

- the data pin contact has been successfully debounced (see [Success in Detecting Data Pin Contact \(Phase Completion\)](#)), or
- a timeout occurs (see [Charger Detection Sequence Timeout](#)).

42.5.1.3.2 Success in Detecting Data Pin Contact (Phase Completion)

After successfully debouncing the D+ state, the module does the following:

Functional Description

- updates the STATUS register to reflect phase completion (See [Table 42-18](#) for field values.)
- directly proceeds to the next step in the sequence: detection of a charging port See [Charging Port Detection](#).

42.5.1.4 Charging Port Detection

Once it is known that the data pins have made contact, the module waits for a fixed delay of 1 ms, and then attempts to detect if it has been plugged into a charging port. The module connects the following analog units to the USB D+ or D- lines during this phase (when the `usbdcd_en` and `usbdcd_chg_det_en` signals are asserted high):

- The voltage source V_{DP_SRC} connects to the D+ line
- The current sink I_{DM_SINK} connects to the D- line
- The voltage comparator connects to the USB D- line, comparing it to the voltage V_{DAT_REF} .

After a time of T_{VDPSRC_ON} , the module samples the D- line. The T_{VDPSRC_ON} parameter is programmable and defaults to 40 ms. After sampling the D- line, the module disconnects the voltage source, current sink, and comparator.

The next steps in the sequence depend on the voltage on the D- line as determined by the voltage comparator. See the following table.

Table 42-16. Sampling D- in the Charging Port Detection Phase

If the voltage on D- is...	Then...	See...
Below V_{DAT_REF}	The port is a <i>standard host</i> that does not support the USB Battery Charging Specification v1.1.	Standard Host Port
Above V_{DAT_REF} but below V_{LGC}	The port is a <i>charging port</i> .	Charging Port
Above V_{LGC}	This is an error condition..	Error in Charging Port Detection

42.5.1.4.1 Standard Host Port

As part of the charger detection handshake with a standard USB host, the module does the following (without waiting for the T_{VDPSRC_CON} interval to elapse):

- Updates the STATUS register to reflect that a standard host has been detected with `SEQ_RES = 01`. (See [Table 42-18](#) for field values.)

- Sets the CONTROL[IF] bit.
- Generates an interrupt if enabled (the CONTROL[IE] bit is set).

At this point, control has been passed to system software via the interrupt. The rest of the sequence (detecting the type of charging port) is not applicable, so software should:

1. Read the STATUS register.
2. Set the CONTROL[IACK] bit to acknowledge the interrupt.
3. Set the CONTROL[SR] bit to issue a software reset to the module.
4. Disable the module.
5. Communicate the appropriate charge rate to the external battery charger IC; see [Table 42-13](#).

42.5.1.4.2 Charging Port

As part of the charger detection handshake with any type of USB host, the module waits until the T_{VDPSRC_CON} interval has elapsed before doing the following:

- Updates the STATUS register to reflect that a charging port has been detected with SEQ_RES = 10. (See [Table 42-18](#) for field values.)
- Sets the CONTROL[IF] bit.
- Generates an interrupt if enabled (the CONTROL[IE] bit is set).

At this point, control has passed to system software via the interrupt. Software should:

1. Read the STATUS register.
2. Set the CONTROL[IACK] bit to acknowledge the interrupt.
3. Issue a command to the USB controller to pullup the USB D+ line.
4. Wait for the module to complete the final phase of the sequence. See [Charger Type Detection](#).

42.5.1.4.3 Error in Charging Port Detection

For this error condition, the module does the following:

Functional Description

- Updates the STATUS register to reflect the error with SEQ_RES = 00. (See [Table 42-18](#) for field values.)
- Sets the CONTROL[IF] bit.
- Generates an interrupt if enabled (the CONTROL[IE] bit is set).

Note that in this case the module does not wait for the T_{VDPSRC_CON} interval to elapse.

At this point, control has been passed to system software via the interrupt. The rest of the sequence (detecting the type of charging port) is not applicable, so software should:

1. Read the STATUS register.
2. Set the CONTROL[IACK] bit to acknowledge the interrupt.
3. Set the CONTROL[SR] bit to issue a software reset to the module.
4. Disable the module.

42.5.1.5 Charger Type Detection

After software enables the D+ pullup resistor, the module is notified automatically (via internal signaling; the module waits until the ipp_pue_pullup_dp input goes high) to start the CHECK_DM timer counting down the time interval programmed into the TIMER2[CHECK_DM] field.

Once the CHECK_DM time has elapsed, the module samples the USB D- line to determine the type of charger. See the following table.

Table 42-17. Sampling D- in the Charger Type Detection Phase

If the voltage on D- is...	Then...	See...
High	The port is a <i>dedicated charging port</i> . ¹	Dedicated Charging Port
Low	The port is a <i>charging host port</i> . ²	Charging Host Port

1. In a dedicated charger, the D+ and D- lines are shorted together through a small resistor.

2. In a charging host port, the D+ and D- lines are not shorted.

42.5.1.5.1 Dedicated Charging Port

For a dedicated charger, the module does the following:

- Updates the STATUS register to reflect that a dedicated charger has been detected with SEQ_RES = 11. (See [Table 42-18](#) for field values.)
- Sets the CONTROL[IF] bit.
- Generates an interrupt if enabled (the CONTROL[IE] bit is set).

At this point, control has been passed to system software via the interrupt. Software should:

1. Read the STATUS register.
2. Disable the USB controller to prevent transitions on the USB D+ or D- lines from causing spurious interrupt or wake-up events to the system.
3. Set the CONTROL[IACK] bit to acknowledge the interrupt.
4. Set the CONTROL[SR] bit to issue a software reset to the module.
5. Disable the module.
6. Communicate the appropriate charge rate to the external battery charger IC; see [Table 42-13](#).

42.5.1.5.2 Charging Host Port

For a charging host port, the module does the following:

- Updates the STATUS register to reflect that a charging host port has been detected with SEQ_RES = 10. (See [Table 42-18](#) for field values.)
- Sets the CONTROL[IF] bit.
- Generates an interrupt if enabled (the CONTROL[IE] bit is set).

At this point, control has been passed to system software via the interrupt. Software should:

1. Read the STATUS register.
2. Set the CONTROL[IACK] bit to acknowledge the interrupt.
3. Set the CONTROL[SR] bit to issue a software reset to the module.
4. Disable the module.
5. Communicate the appropriate charge rate to the external battery charger IC; see [Table 42-13](#).

42.5.1.6 Charger Detection Sequence Timeout

The maximum time to connect allowed under the *USB Battery Charging Specification, v1.1* is one second. If the Unit Connection Timer reaches the one second limit and the sequence is still running (indicated by the STATUS[ACTIVE] bit still being set), the module does the following:

- Updates the STATUS register to reflect that a timeout error has occurred. (See [Table 42-18](#) for field values.)
- Sets the CONTROL[IF] bit.
- Generates an interrupt if enabled (the CONTROL[IE] bit is set).
- The detection sequence continues until explicitly halted by software setting the CONTROL[SR] bit.
- The Unit Connection Timer continues counting. See the description of the TIMER0 Register.

At this point, control has been passed to system software via the interrupt, which has two options: ignore the interrupt and allow more time for the sequence to complete, or halt the sequence. To halt the sequence, software should:

1. Read the STATUS register.
2. Set the CONTROL[IACK] bit to acknowledge the interrupt.
3. Set the CONTROL[SR] bit to issue a software reset to the module.
4. Disable the module.

This timeout function is also useful in case software does not realize that the user unplugged the USB device from the USB port during the charger detection sequence. If the interrupt occurs but the V_{BUS_DETECT} input is low, software can disable and reset the module.

System software might allow the sequence to run past the timeout interrupt under these conditions:

1. the USB Battery Charging Spec is amended to allow more time. In this case, software should poll the T_{UNITCON} register field (see the description of the TIMER0 Register) periodically to track elapsed time after 1s; or
2. for debug purposes.

Note that the T_{UNITCON} register field will stop incrementing when it reaches its maximum value so it will not rollover to zero and start counting up again.

42.5.2 Interrupts and Events

The USBDCD module has an interrupt to alert system software of certain events, which are listed in the following table. All events except the Phase Complete event for the Data Pin Detection phase can trigger an interrupt.

Table 42-18. Events Triggering an Interrupt by Sequence Phase

Sequence Phase	Event	Event Description	STATUS Fields ¹	Phase Description
Data Pin Detection	Phase Complete	The module has detected data pin contact. <i>No interrupt occurs: CONTROL[IF] = 0.</i>	ERR = 0 SEQ_STAT = 01 SEQ_RES = 00 TO = 0	VBUS Contact Detection
Charging Port Detection	Phase Complete	The module has completed the process of identifying if the USB port is a charging port or not.	ERR = 0 SEQ_STAT = 10 SEQ_RES = 01 or 10 TO = 0	Charging Port Detection
	Error	The module cannot identify the type of port because the D- line is above the USB's VLGC threshold.	ERR = 1 SEQ_STAT = 10 SEQ_RES = 00 TO = 0	Error in Charging Port Detection
Charger Type Detection	Phase Complete	The module has completed the process of identifying the charger type detection. Note: The ERR flag always reads as zero because no known error conditions are checked during this phase.	ERR = 0 SEQ_STAT = 11 SEQ_RES = 11 or 10 TO = 0	Charger Type Detection
Sequence Timeout	Error	The timeout interval from the time the USB device attaches to a USB port until it connects has elapsed	ERR = 1 SEQ_STAT = last value ² SEQ_RES = last value ² TO = 1	Charger Detection Sequence Timeout.

1. See the description of the Status Register for register information.

2. The SEQ_STAT and SEQ_RES fields retain the values held at the time of the timeout error.

42.5.2.1 Interrupt Handling

Software can read which event caused the interrupt from the STATUS register during the interrupt service routine.

Functional Description

An interrupt is generated only if the CONTROL[IE] bit is set. The CONTROL[IF] bit is always set under interrupt conditions, even if the IE bit is cleared. In this case, software can poll the IF flag to determine if an interrupt condition is pending.

Writes to the IF bit are ignored. To reset the IF bit, set the CONTROL[IACK] bit to acknowledge the interrupt. Writing to the IACK bit while the IF bit is cleared has no effect.

42.5.3 Resets

There are two ways to reset various register contents in this module: hardware resets and a software reset.

42.5.3.1 Hardware Resets

Hardware resets originate at the system or device level and propagate down to the individual module level. They include power-on reset, low-voltage reset, and all other hardware reset sources.

Hardware resets cause the register contents to be restored to their default state as listed in the register descriptions.

42.5.3.2 Software Reset

A software reset re-initializes the module's status information but leaves configuration information unchanged. The software reset allows software to prepare the module without needing to reprogram the same configuration each time the USB device is plugged into a USB port.

Setting the CONTROL[SR] bit initiates a software reset. The following table shows what register fields are reset to their default values by a software reset.

Table 42-19. Software Reset and Register Fields Affected

Register	Fields Affected	Fields Not Affected
CONTROL ¹	[IF]	[IE, START]
STATUS	All	None
CLOCK	None	All
TIMER _n	TUNITCON	All other

1. The CONTROL[SR, IACK] bits are self-clearing.

A software reset also returns all internal logic, timers, and counters to their reset states. State Machines return to IDLE. If the module is already active (STATUS[ACTIVE] = 1), a software reset stops the sequence.

Note

Software should always initiate a software reset before starting the sequence (setting the CONTROL[START] bit) to ensure the module is in a known state.

42.6 Initialization Information

This module has been designed for minimal configuration while retaining significant programmability. The CLOCK register needs to be initialized to the actual system clock frequency (unless the default value already matches the system requirements).

The other registers generally do not need to be modified because they default to values that comply with the USB Battery Charging Specification v1.1. However, several timing parameters can be changed for a great deal of flexibility if a particular system requires it.

All module configuration must occur *before* initiating the charger detection sequence. Configuration changes made *after* setting the CONTROL[START] bit result in undefined behavior.

42.7 Application Information

This section provides application information.

42.7.1 External Pullups

Any external pullups applied to the USB D+ or D- data lines must be capable of being disabled to prevent incorrect pullup values or incorrect operation of the USB subsystem.

42.7.2 Dead or Weak Battery

According to the USB Battery Charging Specification v1.1, a USB device with a dead, weak, or missing battery that is attached to a charging port can remain attached indefinitely drawing up to 1.5A until the battery is charged to the point that the USB device can connect.

The USBDCD module is compatible with systems that do not check the strength of the battery. Therefore, this module assumes that the battery is good, so the USB device must immediately connect to the USB bus by pulling the D+ line high after the USBDCD module has determined that the device is attached to a charging port. The module is also compatible with systems that do check the strength of the battery. In these systems, if it is known that the battery is weak or dead, software can delay connecting to the USB while charging at 1.5A. Once the battery is charged to the good battery threshold, software can then connect to the USB host by pulling the D+ line high.

42.7.3 Handling Unplug Events

If the device is unplugged from the USB bus during the charger detection sequence, the contents of the STATUS register should be ignored and the USBDCD module should get a Software Reset, as described in [Software Reset](#).

Chapter 43

USB Voltage Regulator

43.1 Introduction

NOTE

For the chip-specific implementation details of this module's instances see the chip configuration chapter.

The USB Voltage Regulator module is a LDO linear voltage regulator to provide 3.3V power from an input power supply varying from 2.7 V to 5.5 V. It consists of one 3.3 V power channel. When the input power supply is below 3.6 V, the regulator goes to pass-through mode. The following figure shows the ideal relation between the regulator output and input power supply.

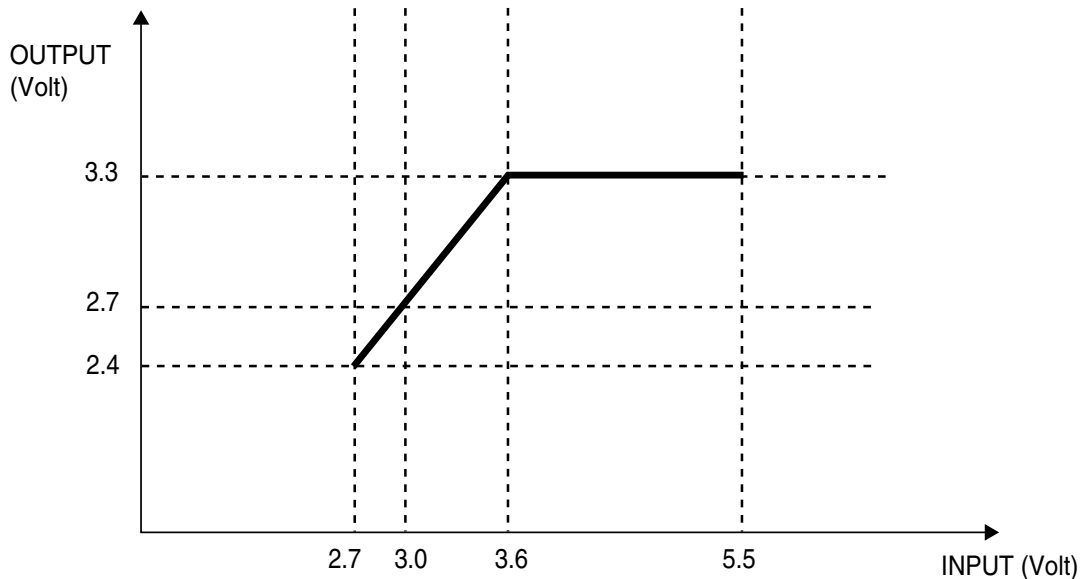

Figure 43-1. Ideal Relation Between the Regulator Output and Input Power Supply

43.1.1 Overview

A simplified block diagram for the USB Voltage Regulator module is shown below.

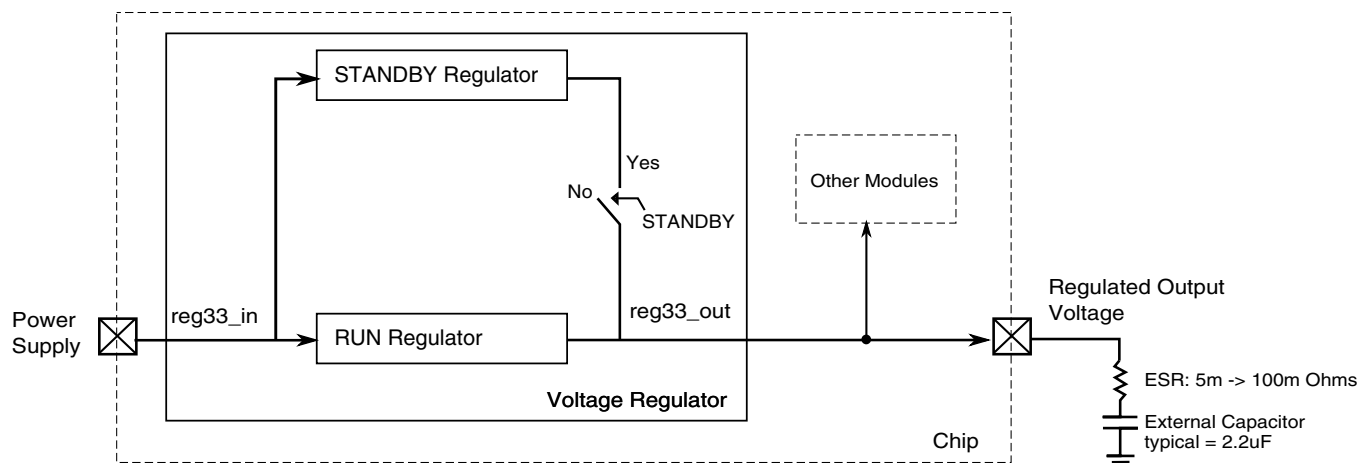

Figure 43-2. USB Voltage Regulator Block Diagram

This module uses 2 regulators in parallel. In run mode, the RUN regulator with the bandgap voltage reference is enabled and can provide up to 120 mA load current. In run mode, the STANDBY regulator and the low power reference are also enabled, but a switch disconnects its output from the external pin. In STANDBY mode, the RUN regulator is disabled and the STANDBY regulator output is connected to the external pin supplying up to 3 mA load current.

Internal power mode signals control whether the module is in RUN or STANDBY mode.

43.1.2 Features

- Low drop-out linear voltage regulator with one power channel (3.3V).
- Low drop-out voltage: 300 mV.
- Output current: 120 mA.
- Three different power modes: RUN, STANDBY and SHUTDOWN.
- Low quiescent current in RUN mode.
 - Typical value is around 120 uA (one thousand times smaller than the maximum load current).
- Very low quiescent current in STANDBY mode.
 - Typical value is around 1 uA.

- Automatic current limiting if the load current is greater than 290 mA.
- Automatic power-up once some voltage is applied to the regulator input.
- Pass-through mode for regulator input voltages less than 3.6 V
- Small output capacitor: 2.2 uF
- Stable with aluminum, tantalum or ceramic capacitors.

43.1.3 Modes of Operation

The regulator has these power modes:

- **RUN**—The regulating loop of the RUN regulator and the STANDBY regulator are active, but the switch connecting the STANDBY regulator output to the external pin is open.
- **STANDBY**—The regulating loop of the RUN regulator is disabled and the standby regulator is active. The switch connecting the STANDBY regulator output to the external pin is closed.
- **SHUTDOWN**—The module is disabled.

The regulator is enabled by default. This means that once the power supply is provided, the module power-up sequence to RUN mode starts.

43.2 USB Voltage Regulator Module Signal Descriptions

The following table shows the external signals for the regulator.

Table 43-1. USB Voltage Regulator Module Signal Descriptions

Signal	Description	I/O
reg33_in	Unregulated power supply	I
reg33_out	Regulator output voltage	O



Chapter 44

CAN (FlexCAN)

44.1 Introduction

NOTE

For the chip-specific implementation details of this module's instances see the chip configuration chapter.

The FlexCAN module is a communication controller implementing the CAN protocol according to the CAN 2.0B protocol specification. A general block diagram is shown in the following figure, which describes the main sub-blocks implemented in the FlexCAN module, including one associated memory for storing Message Buffers, Rx Global Mask Registers, Rx Individual Mask Registers, Rx FIFO and Rx FIFO ID Filters. The functions of the sub-modules are described in subsequent sections.

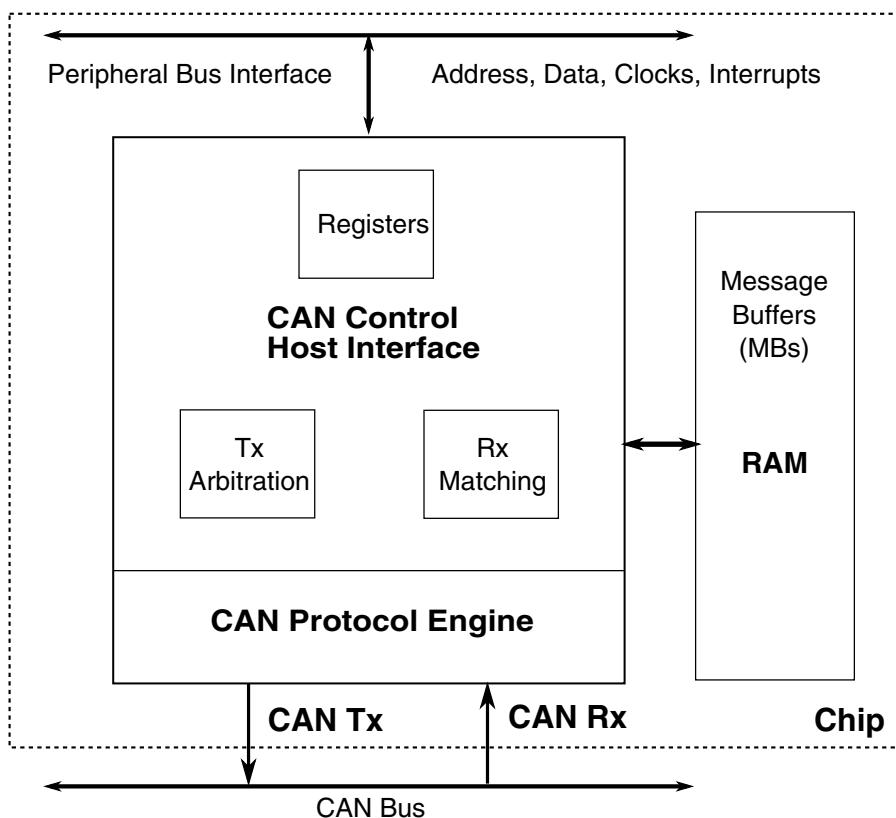

Figure 44-1. FlexCAN Block Diagram

44.1.1 Overview

The CAN protocol was primarily, but not only, designed to be used as a vehicle serial data bus, meeting the specific requirements of this field: real-time processing, reliable operation in the EMI environment of a vehicle, cost-effectiveness and required bandwidth. The FlexCAN module is a full implementation of the CAN protocol specification, Version 2.0 B, which supports both standard and extended message frames. The Message Buffers are stored in an embedded RAM dedicated to the FlexCAN module. See the Chip Configuration details for the actual number of Message Buffers configured in the MCU.

The CAN Protocol Engine (PE) sub-module manages the serial communication on the CAN bus, requesting RAM access for receiving and transmitting message frames, validating received messages and performing error handling. The Controller Host Interface (CHI) sub-module handles Message Buffer selection for reception and transmission, taking care of arbitration and ID matching algorithms. The Bus Interface Unit (BIU) sub-module controls the access to and from the internal interface bus, in order to establish connection to the CPU and to other blocks. Clocks, address and data buses, interrupt outputs and test signals are accessed through the Bus Interface Unit.

44.1.2 FlexCAN Module Features

The FlexCAN module includes these distinctive legacy features:

- Full Implementation of the CAN protocol specification, Version 2.0B
 - Standard data and remote frames
 - Extended data and remote frames
 - Zero to eight bytes data length
 - Programmable bit rate up to 1 Mb/sec
 - Content-related addressing
- Flexible Mailboxes of zero to eight bytes data length
- Each Mailbox configurable as Rx or Tx, all supporting standard and extended messages
- Individual Rx Mask Registers per Mailbox
- Full featured Rx FIFO with storage capacity for up to 6 frames and automatic internal pointer handling
- Transmission abort capability
- Programmable clock source to the CAN Protocol Interface, either bus clock or crystal oscillator
- Unused structures space can be used as general purpose RAM space
- Listen-only mode capability
- Programmable loop-back mode supporting self-test operation
- Programmable transmission priority scheme: lowest ID, lowest buffer number or highest priority
- Time Stamp based on 16-bit free-running timer
- Global network time, synchronized by a specific message
- Maskable interrupts
- Independent of the transmission medium (an external transceiver is assumed)

- Short latency time due to an arbitration scheme for high-priority messages
- Low power modes, with programmable wake up on bus activity

Furthermore, the new major features below are also provided in addition to the previous FlexCAN version:

- Remote request frames may be handled automatically or by software
- Safe mechanism for ID Filter configuration in Normal Mode
- CAN bit time settings and configuration bits can only be written in "Freeze" mode
- Tx mailbox status (Lowest priority buffer or empty buffer)
- IDHIT register for received frames
- SYNC bit status to inform that the module is synchronous with CAN bus
- Debug Registers
- CRC status for transmitted message
- Rx FIFO Global Mask register
- Selectable priority of reception between Mailboxes and Rx FIFO during matching process
- Powerful Rx FIFO ID filtering, capable of matching incoming IDs against either 128 extended, 256 standard or 512 partial (8 bits) IDs, with up to 32 individual masking capability
- 100% backward compatibility with previous FlexCAN version

44.1.3 Modes of Operation

The FlexCAN module has four functional modes: Normal Mode (User and Supervisor), Freeze Mode, Listen-Only Mode and Loop-Back Mode. There are also three low power modes: Disable Mode, Doze Mode and Stop Mode.

- Normal Mode (User or Supervisor):

In Normal Mode, the module operates receiving and/or transmitting message frames, errors are handled normally and all the CAN Protocol functions are enabled. User and Supervisor Modes differ in the access to some restricted control registers.

- Freeze Mode:

It is enabled when the FRZ bit in the MCR Register is asserted. If enabled, Freeze Mode is entered when the HALT bit in MCR is set or when Debug Mode is requested at MCU level and the FRZ_ACK bit in the MCR Register is asserted by the FlexCAN. In this mode, no transmission or reception of frames is done and synchronicity to the CAN bus is lost. See [Freeze Mode](#) for more information.

- Listen-Only Mode:

The module enters this mode when the LOM bit in the Control 1 Register is asserted. In this mode, transmission is disabled, all error counters are frozen and the module operates in a CAN Error Passive mode. Only messages acknowledged by another CAN station will be received. If FlexCAN detects a message that has not been acknowledged, it will flag a BIT0 error (without changing the REC), as if it was trying to acknowledge the message.

- Loop-Back Mode:

The module enters this mode when the LPB bit in the Control 1 Register is asserted. In this mode, FlexCAN performs an internal loop back that can be used for self test operation. The bit stream output of the transmitter is internally fed back to the receiver input. The Rx CAN input pin is ignored and the Tx CAN output goes to the recessive state (logic '1'). FlexCAN behaves as it normally does when transmitting and treats its own transmitted message as a message received from a remote node. In this mode, FlexCAN ignores the bit sent during the ACK slot in the CAN frame acknowledge field to ensure proper reception of its own message. Both transmit and receive interrupts are generated.

- Module Disable Mode:

This low power mode is entered when the MDIS bit in the MCR Register is asserted by the CPU and the LPM_ACK is asserted by the FlexCAN. When disabled, the module requests to disable the clocks to the CAN Protocol Engine and Controller Host Interface sub-modules. Exit from this mode is done by negating the MDIS bit in the MCR Register. See [Module Disable Mode](#) for more information.

- Doze Mode:

This low power mode is entered when the DOZE bit in MCR is asserted and Doze Mode is requested at MCU level and the LPM_ACK bit in the MCR Register is asserted by the FlexCAN. When in Doze Mode, the module requests to disable the clocks to the CAN Protocol Engine and the CAN Controller-Host Interface sub-modules. Exit from this mode happens when the DOZE bit in MCR is negated, when the MCU is removed from Doze Mode, or when activity is detected on the CAN bus and the Self Wake Up mechanism is enabled. See [Doze Mode](#) for more information.

- Stop Mode:

This low power mode is entered when Stop Mode is requested at MCU level and the LPM_ACK bit in the MCR Register is asserted by the FlexCAN. When in Stop Mode, the module puts itself in an inactive state and then informs the CPU that the clocks can be shut down globally. Exit from this mode happens when the Stop Mode request is removed or when activity is detected on the CAN bus and the Self Wake Up mechanism is enabled. See [Stop Mode](#) for more information.

44.2 FlexCAN Signal Descriptions

The FlexCAN module has two I/O signals connected to the external MCU pins. These signals are summarized in the following table and described in more detail in the next sub-sections.

Table 44-1. FlexCAN Signal Descriptions

Signal	Description	I/O
CAN Rx	CAN Receive Pin	Input
CAN Tx	CAN Transmit Pin	Output

44.2.1 CAN Rx

This pin is the receive pin from the CAN bus transceiver. Dominant state is represented by logic level '0'. Recessive state is represented by logic level '1'.

44.2.2 CAN Tx

This pin is the transmit pin to the CAN bus transceiver. Dominant state is represented by logic level '0'. Recessive state is represented by logic level '1'.

44.3 Memory Map/Register Definition

This section describes the registers and data structures in the FlexCAN module. The base address of the module depends on the particular memory map of the MCU.

44.3.1 FlexCAN Memory Mapping

The complete memory map for a FlexCAN module is shown in the following table.

The address space occupied by FlexCAN has 128 bytes for registers starting at the module base address, followed by embedded RAM starting at address 0x0080.

Each individual register is identified by its complete name and the corresponding mnemonic. The access type can be Supervisor (S) or Unrestricted (U). Most of the registers can be configured to have either Supervisor or Unrestricted access by programming the SUPV bit in the MCR Register. These registers are identified as S/U in the Access column of [Table 44-2](#).

The registers IFLAG2 and IMASK2 are considered reserved space depending on the number of Mailboxes available in the device.

Table 44-2. Module Memory Map

Register	Access Type	Affected by Hard Reset	Affected by Soft Reset
Module Configuration Register (MCR)	S	Yes	Yes
Control 1 Register (CTRL1)	S/U	Yes	No
Free Running Timer Register (TIMER)	S/U	Yes	Yes
Rx Mailboxes Global Mask Register (RXMGMASK)	S/U	No	No
Rx Buffer 14 Mask Register (RX14MASK)	S/U	No	No
Rx Buffer 15 Mask Register (RX15MASK)	S/U	No	No
Error Counter Register (ECR)	S/U	Yes	Yes
Error and Status 1 Register (ESR1)	S/U	Yes	Yes
Interrupt Masks 2 Register (IMASK2)	S/U	Yes	Yes
Interrupt Masks 1 Register (IMASK1)	S/U	Yes	Yes
Interrupt Flags 2 Register (IFLAG2)	S/U	Yes	Yes
Interrupt Flags 1 Register (IFLAG1)	S/U	Yes	Yes
Control 2 Register (CTRL2)	S/U	Yes	No
Error and Status 2 Register (ESR2)	S/U	Yes	Yes
Individual Matching Elements Update Register (IMUER)	S/U	Yes	Yes
Lost Rx Frames Register (LRFR)	S/U	Yes	Yes
CRC Register (CRCR)	S/U	Yes	Yes
Rx FIFO Global Mask Register (RXFGMASK)	S/U	No	No
Rx FIFO Information Register (RXFIR)	S/U	No	No
Message Buffers	S/U	No	No
Rx Individual Mask Registers	S/U	No	No

The FlexCAN module can store CAN messages for transmission and reception using Mailboxes and Rx FIFO structures.

This module's memory map includes sixteen 128-bit message buffers (MBs) that occupy the range from offset 0x80 to 0x17F.

CAN memory map

Absolute address (hex)	Register name	Width (in bits)	Access	Reset value	Section/page
4002_4000	Module Configuration Register (CAN0_MCR)	32	R/W	D890_000Fh	44.3.2/1078
4002_4004	Control 1 Register (CAN0_CTRL1)	32	R/W	0000_0000h	44.3.3/1083
4002_4008	Free Running Timer (CAN0_TIMER)	32	R/W	0000_0000h	44.3.4/1086
4002_4010	Rx Mailboxes Global Mask Register (CAN0_RXMGMASK)	32	R/W	FFFF_FFFFh	44.3.5/1087
4002_4014	Rx 14 Mask Register (CAN0_RX14MASK)	32	R/W	FFFF_FFFFh	44.3.6/1088
4002_4018	Rx 15 Mask Register (CAN0_RX15MASK)	32	R/W	FFFF_FFFFh	44.3.7/1089
4002_401C	Error Counter (CAN0_ECR)	32	R/W	0000_0000h	44.3.8/1090
4002_4020	Error and Status 1 Register (CAN0_ESR1)	32	R/W	0000_0000h	44.3.9/1091
4002_4024	Interrupt Masks 2 Register (CAN0_IMASK2)	32	R/W	0000_0000h	44.3.10/1095
4002_4028	Interrupt Masks 1 Register (CAN0_IMASK1)	32	R/W	0000_0000h	44.3.11/1096
4002_402C	Interrupt Flags 2 Register (CAN0_IFLAG2)	32	R/W	0000_0000h	44.3.12/1096
4002_4030	Interrupt Flags 1 Register (CAN0_IFLAG1)	32	R/W	0000_0000h	44.3.13/1097
4002_4034	Control 2 Register (CAN0_CTRL2)	32	R/W	00C0_0000h	44.3.14/1100
4002_4038	Error and Status 2 Register (CAN0_ESR2)	32	R/W	0000_0000h	44.3.15/1103
4002_4044	CRC Register (CAN0_CRCR)	32	R	0000_0000h	44.3.16/1104
4002_4048	Rx FIFO Global Mask Register (CAN0_RXFGMASK)	32	R/W	FFFF_FFFFh	44.3.17/1105
4002_404C	Rx FIFO Information Register (CAN0_RXFIR)	32	R	Undefined	44.3.18/1106

Table continues on the next page...

CAN memory map (continued)

Absolute address (hex)	Register name	Width (in bits)	Access	Reset value	Section/page
4002_4880	Rx Individual Mask Registers (CAN0_RXIMR0)	32	R/W	Undefined	44.3.19/1107
4002_4884	Rx Individual Mask Registers (CAN0_RXIMR1)	32	R/W	Undefined	44.3.19/1107
4002_4888	Rx Individual Mask Registers (CAN0_RXIMR2)	32	R/W	Undefined	44.3.19/1107
4002_488C	Rx Individual Mask Registers (CAN0_RXIMR3)	32	R/W	Undefined	44.3.19/1107
4002_4890	Rx Individual Mask Registers (CAN0_RXIMR4)	32	R/W	Undefined	44.3.19/1107
4002_4894	Rx Individual Mask Registers (CAN0_RXIMR5)	32	R/W	Undefined	44.3.19/1107
4002_4898	Rx Individual Mask Registers (CAN0_RXIMR6)	32	R/W	Undefined	44.3.19/1107
4002_489C	Rx Individual Mask Registers (CAN0_RXIMR7)	32	R/W	Undefined	44.3.19/1107
4002_48A0	Rx Individual Mask Registers (CAN0_RXIMR8)	32	R/W	Undefined	44.3.19/1107
4002_48A4	Rx Individual Mask Registers (CAN0_RXIMR9)	32	R/W	Undefined	44.3.19/1107
4002_48A8	Rx Individual Mask Registers (CAN0_RXIMR10)	32	R/W	Undefined	44.3.19/1107
4002_48AC	Rx Individual Mask Registers (CAN0_RXIMR11)	32	R/W	Undefined	44.3.19/1107
4002_48B0	Rx Individual Mask Registers (CAN0_RXIMR12)	32	R/W	Undefined	44.3.19/1107
4002_48B4	Rx Individual Mask Registers (CAN0_RXIMR13)	32	R/W	Undefined	44.3.19/1107
4002_48B8	Rx Individual Mask Registers (CAN0_RXIMR14)	32	R/W	Undefined	44.3.19/1107
4002_48BC	Rx Individual Mask Registers (CAN0_RXIMR15)	32	R/W	Undefined	44.3.19/1107
400A_4000	Module Configuration Register (CAN1_MCR)	32	R/W	D890_000Fh	44.3.2/1078
400A_4004	Control 1 Register (CAN1_CTRL1)	32	R/W	0000_0000h	44.3.3/1083
400A_4008	Free Running Timer (CAN1_TIMER)	32	R/W	0000_0000h	44.3.4/1086
400A_4010	Rx Mailboxes Global Mask Register (CAN1_RXMGMASK)	32	R/W	FFFF_FFFFh	44.3.5/1087

Table continues on the next page...

CAN memory map (continued)

Absolute address (hex)	Register name	Width (in bits)	Access	Reset value	Section/page
400A_4014	Rx 14 Mask Register (CAN1_RX14MASK)	32	R/W	FFFF_FFFFh	44.3.6/1088
400A_4018	Rx 15 Mask Register (CAN1_RX15MASK)	32	R/W	FFFF_FFFFh	44.3.7/1089
400A_401C	Error Counter (CAN1_ECR)	32	R/W	0000_0000h	44.3.8/1090
400A_4020	Error and Status 1 Register (CAN1_ESR1)	32	R/W	0000_0000h	44.3.9/1091
400A_4024	Interrupt Masks 2 Register (CAN1_IMASK2)	32	R/W	0000_0000h	44.3.10/1095
400A_4028	Interrupt Masks 1 Register (CAN1_IMASK1)	32	R/W	0000_0000h	44.3.11/1096
400A_402C	Interrupt Flags 2 Register (CAN1_IFLAG2)	32	R/W	0000_0000h	44.3.12/1096
400A_4030	Interrupt Flags 1 Register (CAN1_IFLAG1)	32	R/W	0000_0000h	44.3.13/1097
400A_4034	Control 2 Register (CAN1_CTRL2)	32	R/W	00C0_0000h	44.3.14/1100
400A_4038	Error and Status 2 Register (CAN1_ESR2)	32	R/W	0000_0000h	44.3.15/1103
400A_4044	CRC Register (CAN1_CRCR)	32	R	0000_0000h	44.3.16/1104
400A_4048	Rx FIFO Global Mask Register (CAN1_RXFGMASK)	32	R/W	FFFF_FFFFh	44.3.17/1105
400A_404C	Rx FIFO Information Register (CAN1_RXFIR)	32	R	Undefined	44.3.18/1106
400A_4880	Rx Individual Mask Registers (CAN1_RXIMR0)	32	R/W	Undefined	44.3.19/1107
400A_4884	Rx Individual Mask Registers (CAN1_RXIMR1)	32	R/W	Undefined	44.3.19/1107
400A_4888	Rx Individual Mask Registers (CAN1_RXIMR2)	32	R/W	Undefined	44.3.19/1107
400A_488C	Rx Individual Mask Registers (CAN1_RXIMR3)	32	R/W	Undefined	44.3.19/1107
400A_4890	Rx Individual Mask Registers (CAN1_RXIMR4)	32	R/W	Undefined	44.3.19/1107
400A_4894	Rx Individual Mask Registers (CAN1_RXIMR5)	32	R/W	Undefined	44.3.19/1107
400A_4898	Rx Individual Mask Registers (CAN1_RXIMR6)	32	R/W	Undefined	44.3.19/1107

Table continues on the next page...

CAN memory map (continued)

Absolute address (hex)	Register name	Width (in bits)	Access	Reset value	Section/page
400A_489C	Rx Individual Mask Registers (CAN1_RXIMR7)	32	R/W	Undefined	44.3.19/1107
400A_48A0	Rx Individual Mask Registers (CAN1_RXIMR8)	32	R/W	Undefined	44.3.19/1107
400A_48A4	Rx Individual Mask Registers (CAN1_RXIMR9)	32	R/W	Undefined	44.3.19/1107
400A_48A8	Rx Individual Mask Registers (CAN1_RXIMR10)	32	R/W	Undefined	44.3.19/1107
400A_48AC	Rx Individual Mask Registers (CAN1_RXIMR11)	32	R/W	Undefined	44.3.19/1107
400A_48B0	Rx Individual Mask Registers (CAN1_RXIMR12)	32	R/W	Undefined	44.3.19/1107
400A_48B4	Rx Individual Mask Registers (CAN1_RXIMR13)	32	R/W	Undefined	44.3.19/1107
400A_48B8	Rx Individual Mask Registers (CAN1_RXIMR14)	32	R/W	Undefined	44.3.19/1107
400A_48BC	Rx Individual Mask Registers (CAN1_RXIMR15)	32	R/W	Undefined	44.3.19/1107

44.3.2 Module Configuration Register (CANx_MCR)

This register defines global system configurations, such as the module operation modes and the maximum message buffer configuration.

Addresses: CAN0_MCR is 4002_4000h base + 0h offset = 4002_4000h

CAN1_MCR is 400A_4000h base + 0h offset = 400A_4000h

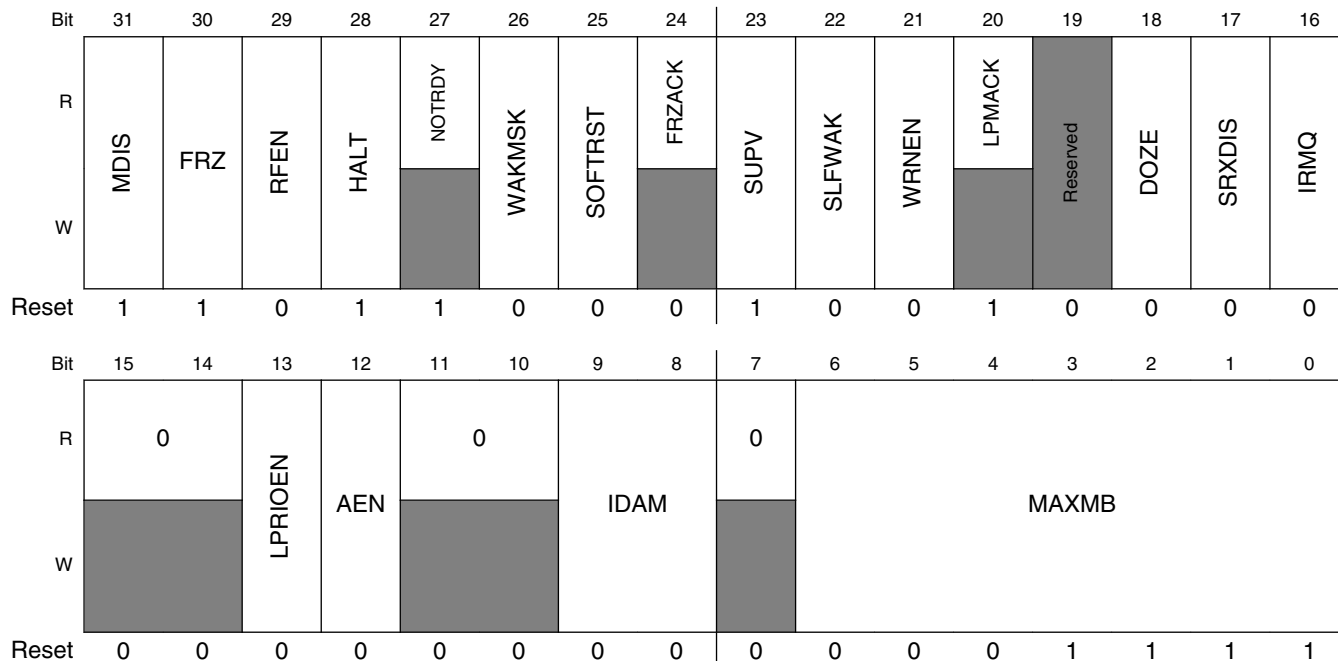

CANx_MCR field descriptions

Field	Description
31 MDIS	<p>Module Disable</p> <p>This bit controls whether FlexCAN is enabled or not. When disabled, FlexCAN disables the clocks to the CAN Protocol Engine and Controller Host Interface sub-modules. This is the only bit in MCR not affected by soft reset.</p> <p>0 Enable the FlexCAN module. 1 Disable the FlexCAN module.</p>
30 FRZ	<p>Freeze Enable</p> <p>The FRZ bit specifies the FlexCAN behavior when the HALT bit in the MCR Register is set or when Debug Mode is requested at MCU level. When FRZ is asserted, FlexCAN is enabled to enter Freeze Mode. Negation of this bit field causes FlexCAN to exit from Freeze Mode.</p> <p>0 Not enabled to enter Freeze Mode 1 Enabled to enter Freeze Mode</p>
29 RFEN	<p>Rx FIFO Enable</p>

Table continues on the next page...

CANx_MCR field descriptions (continued)

Field	Description
	<p>This bit controls whether the Rx FIFO feature is enabled or not. When RFEN is set, MBs 0 to 5 cannot be used for normal reception and transmission because the corresponding memory region (0x80-0xDC) is used by the FIFO engine as well as additional MBs (up to 32, depending on CTRL2[RFFN] setting) which are used as Rx FIFO ID Filter Table elements. RFEN also impacts the definition of the minimum number of peripheral clocks per CAN bit as described in the table "Minimum Ratio Between Peripheral Clock Frequency and CAN Bit Rate" (in section "Arbitration and Matching Timing"). This bit can only be written in Freeze mode as it is blocked by hardware in other modes.</p> <p>0 Rx FIFO not enabled 1 Rx FIFO enabled</p>
28 HALT	<p>Halt FlexCAN</p> <p>Assertion of this bit puts the FlexCAN module into Freeze Mode. The CPU should clear it after initializing the Message Buffers and Control Register. No reception or transmission is performed by FlexCAN before this bit is cleared. Freeze Mode cannot be entered while FlexCAN is in a low power mode.</p> <p>0 No Freeze Mode request. 1 Enters Freeze Mode if the FRZ bit is asserted.</p>
27 NOTRDY	<p>FlexCAN Not Ready</p> <p>This read-only bit indicates that FlexCAN is either in Disable Mode, Doze Mode, Stop Mode or Freeze Mode. It is negated once FlexCAN has exited these modes.</p> <p>0 FlexCAN module is either in Normal Mode, Listen-Only Mode or Loop-Back Mode. 1 FlexCAN module is either in Disable Mode, Doze Mode, Stop Mode or Freeze Mode.</p>
26 WAKMSK	<p>Wake Up Interrupt Mask</p> <p>This bit enables the Wake Up Interrupt generation.</p> <p>0 Wake Up Interrupt is disabled. 1 Wake Up Interrupt is enabled.</p>
25 SOFTRST	<p>Soft Reset</p> <p>When this bit is asserted, FlexCAN resets its internal state machines and some of the memory mapped registers. The following registers are reset: MCR (except the MDIS bit), TIMER, ECR, ESR1, ESR2, IMASK1, IMASK2, IFLAG1, IFLAG2 and CRCR. Configuration registers that control the interface to the CAN bus are not affected by soft reset. The following registers are unaffected: CTRL1, CTRL2, RXIMR0–RXIMR63, RXMGMASK, RX14MASK, RX15MASK, RXFGMASK, RXFIR, all Message Buffers.</p> <p>The SOFTRST bit can be asserted directly by the CPU when it writes to the MCR Register, but it is also asserted when global soft reset is requested at MCU level. Since soft reset is synchronous and has to follow a request/acknowledge procedure across clock domains, it may take some time to fully propagate its effect. The SOFTRST bit remains asserted while reset is pending, and is automatically negated when reset completes. Therefore, software can poll this bit to know when the soft reset has completed.</p> <p>Soft reset cannot be applied while clocks are shut down in a low power mode. The module should be first removed from low power mode, and then soft reset can be applied.</p> <p>0 No reset request 1 Resets the registers affected by soft reset.</p>
24 FRZACK	<p>Freeze Mode Acknowledge</p> <p>This read-only bit indicates that FlexCAN is in Freeze Mode and its prescaler is stopped. The Freeze Mode request cannot be granted until current transmission or reception processes have finished.</p>

Table continues on the next page...

CANx_MCR field descriptions (continued)

Field	Description
	<p>Therefore the software can poll the FRZACK bit to know when FlexCAN has actually entered Freeze Mode. If Freeze Mode request is negated, then this bit is negated once the FlexCAN prescaler is running again. If Freeze Mode is requested while FlexCAN is in a low power mode, then the FRZACK bit will only be set when the low power mode is exited. See Section "Freeze Mode".</p> <p>NOTE: FRZACK will be asserted within 178 CAN bits from the freeze mode request by the CPU, and negated within 2 CAN bits after the freeze mode request removal (see Section "Protocol Timing").</p> <p>0 FlexCAN not in Freeze Mode, prescaler running 1 FlexCAN in Freeze Mode, prescaler stopped</p>
23 SUPV	<p>Supervisor Mode</p> <p>This bit configures the FlexCAN to be either in Supervisor or User Mode. The registers affected by this bit are marked as S/U in the Access Type column of the module memory map. Reset value of this bit is '1', so the affected registers start with Supervisor access allowance only. This bit can only be written in Freeze mode as it is blocked by hardware in other modes.</p> <p>0 FlexCAN is in User Mode. Affected registers allow both Supervisor and Unrestricted accesses. 1 FlexCAN is in Supervisor Mode. Affected registers allow only Supervisor access. Unrestricted access behaves as though the access was done to an unimplemented register location.</p>
22 SLFWAK	<p>Self Wake Up</p> <p>This bit enables the Self Wake Up feature when FlexCAN is in a low power mode other than Disable Mode. When this feature is enabled, the FlexCAN module monitors the bus for wake up event, that is, a recessive-to-dominant transition.</p> <p>If a wake up event is detected during Doze Mode, FlexCAN requests to resume its clocks and, if enabled to do so, generates a Wake Up interrupt to the CPU.</p> <p>If a wake up event is detected during Stop Mode, then FlexCAN generates, if enabled to do so, a Wake Up interrupt to the CPU so that it can exit Stop Mode globally and FlexCAN can request to resume the clocks.</p> <p>When FlexCAN is in a low power mode other than Disable Mode, this bit cannot be written as it is blocked by hardware.</p> <p>0 FlexCAN Self Wake Up feature is disabled. 1 FlexCAN Self Wake Up feature is enabled.</p>
21 WRNEN	<p>Warning Interrupt Enable</p> <p>When asserted, this bit enables the generation of the TWRNINT and RWRNINT flags in the Error and Status Register. If WRNEN is negated, the TWRNINT and RWRNINT flags will always be zero, independent of the values of the error counters, and no warning interrupt will ever be generated. This bit can only be written in Freeze mode as it is blocked by hardware in other modes.</p> <p>0 TWRNINT and RWRNINT bits are zero, independent of the values in the error counters. 1 TWRNINT and RWRNINT bits are set when the respective error counter transitions from less than 96 to greater than or equal to 96.</p>
20 LPMACK	<p>Low Power Mode Acknowledge</p> <p>This read-only bit indicates that FlexCAN is in a low power mode (Disable Mode, Doze Mode, Stop Mode). A low power mode can not be entered until all current transmission or reception processes have finished, so the CPU can poll the LPMACK bit to know when FlexCAN has actually entered low power mode.</p>

Table continues on the next page...

CANx_MCR field descriptions (continued)

Field	Description
	<p>NOTE: LPMACK will be asserted within 180 CAN bits from the low power mode request by the CPU, and negated within 2 CAN bits after the low power mode request removal (see Section "Protocol Timing").</p> <p>0 FlexCAN is not in a low power mode. 1 FlexCAN is in a low power mode.</p>
19 Reserved	This field is reserved.
18 DOZE	<p>Doze Mode Enable</p> <p>This bit defines whether FlexCAN is allowed to enter low power mode when Doze Mode is requested at MCU level. This bit is automatically reset when FlexCAN wakes up from Doze Mode upon detecting activity on the CAN bus (self wake-up enabled).</p> <p>0 FlexCAN is not enabled to enter low power mode when Doze Mode is requested. 1 FlexCAN is enabled to enter low power mode when Doze Mode is requested.</p>
17 SRXDIS	<p>Self Reception Disable</p> <p>This bit defines whether FlexCAN is allowed to receive frames transmitted by itself. If this bit is asserted, frames transmitted by the module will not be stored in any MB, regardless if the MB is programmed with an ID that matches the transmitted frame, and no interrupt flag or interrupt signal will be generated due to the frame reception. This bit can only be written in Freeze mode as it is blocked by hardware in other modes.</p> <p>0 Self reception enabled 1 Self reception disabled</p>
16 IRMQ	<p>Individual Rx Masking and Queue Enable</p> <p>This bit indicates whether Rx matching process will be based either on individual masking and queue or on masking scheme with RXMGMASK, RX14MASK and RX15MASK, RXFGMASK. This bit can only be written in Freeze mode as it is blocked by hardware in other modes.</p> <p>0 Individual Rx masking and queue feature are disabled. For backward compatibility, the reading of C/S word locks the MB even if it is EMPTY. 1 Individual Rx masking and queue feature are enabled.</p>
15–14 Reserved	This read-only field is reserved and always has the value zero.
13 LPRIOEN	<p>Local Priority Enable</p> <p>This bit is provided for backwards compatibility reasons. It controls whether the local priority feature is enabled or not. It is used to expand the ID used during the arbitration process. With this expanded ID concept, the arbitration process is done based on the full 32-bit word, but the actual transmitted ID still has 11-bit for standard frames and 29-bit for extended frames. This bit can only be written in Freeze mode as it is blocked by hardware in other modes.</p> <p>0 Local Priority disabled 1 Local Priority enabled</p>
12 AEN	<p>Abort Enable</p> <p>This bit is supplied for backwards compatibility reasons. When asserted, it enables the Tx abort mechanism. This mechanism guarantees a safe procedure for aborting a pending transmission, so that no</p>

Table continues on the next page...

CANx_MCR field descriptions (continued)

Field	Description
	<p>frame is sent in the CAN bus without notification. This bit can only be written in Freeze mode as it is blocked by hardware in other modes.</p> <p>NOTE: When MCR[AEN] is asserted, only the abort mechanism (see Section "Transmission Abort Mechanism") must be used for updating Mailboxes configured for transmission.</p> <p>CAUTION: Writing the Abort code into Rx Mailboxes can cause unpredictable results when the MCR[AEN] is asserted.</p> <p>0 Abort disabled 1 Abort enabled</p>
11–10 Reserved	This read-only field is reserved and always has the value zero.
9–8 IDAM	<p>ID Acceptance Mode</p> <p>This 2-bit field identifies the format of the Rx FIFO ID Filter Table Elements. Note that all elements of the table are configured at the same time by this field (they are all the same format). See Section "Rx FIFO Structure". This field can only be written in Freeze mode as it is blocked by hardware in other modes.</p> <p>00 Format A: One full ID (standard and extended) per ID Filter Table element. 01 Format B: Two full standard IDs or two partial 14-bit (standard and extended) IDs per ID Filter Table element. 10 Format C: Four partial 8-bit Standard IDs per ID Filter Table element. 11 Format D: All frames rejected.</p>
7 Reserved	This read-only field is reserved and always has the value zero.
6–0 MAXMB	<p>Number of the Last Message Buffer</p> <p>This 7-bit field defines the number of the last Message Buffers that will take part in the matching and arbitration processes. The reset value (0x0F) is equivalent to 16 MB configuration. This field can only be written in Freeze Mode as it is blocked by hardware in other modes.</p> <p>Number of the last MB = MAXMB</p> <p>NOTE: MAXMB must be programmed with a value smaller than the parameter NUMBER_OF_MB, otherwise the number of the last effective Message Buffer will be: (NUMBER_OF_MB - 1)</p> <p>Additionally, the value of MAXMB must encompass the FIFO size defined by CTRL2[RFFN]. MAXMB also impacts the definition of the minimum number of peripheral clocks per CAN bit as described in Table "Minimum Ratio Between Peripheral Clock Frequency and CAN Bit Rate" (in Section "Arbitration and Matching Timing").</p>

44.3.3 Control 1 Register (CANx_CTRL1)

This register is defined for specific FlexCAN control features related to the CAN bus, such as bit-rate, programmable sampling point within an Rx bit, Loop Back Mode, Listen-Only Mode, Bus Off recovery behavior and interrupt enabling (Bus-Off, Error, Warning). It also determines the Division Factor for the clock prescaler.

Addresses: CAN0_CTRL1 is 4002_4000h base + 4h offset = 4002_4004h

CAN1_CTRL1 is 400A_4000h base + 4h offset = 400A_4004h

Bit	31	30	29	28	27	26	25	24	23	22	21	20	19	18	17	16
R	PRESDIV								RJW		PSEG1			PSEG2		
W																
Reset	0	0	0	0	0	0	0	0	0	0	0	0	0	0	0	0
Bit	15	14	13	12	11	10	9	8	7	6	5	4	3	2	1	0
R	BOFFMSK	ERRMSK	CLKSRC	LPB	TWRNMSK	RWRNMSK	0		SMP	BOFFREC	TSYN	LBUF	LOM	PROPSEG		
W																
Reset	0	0	0	0	0	0	0	0	0	0	0	0	0	0	0	0

CANx_CTRL1 field descriptions

Field	Description
31–24 PRESDIV	<p>Prescaler Division Factor</p> <p>This 8-bit field defines the ratio between the PE clock frequency and the Serial Clock (Sclock) frequency. The Sclock period defines the time quantum of the CAN protocol. For the reset value, the Sclock frequency is equal to the PE clock frequency. The Maximum value of this field is 0xFF, that gives a minimum Sclock frequency equal to the PE clock frequency divided by 256. See Section "Protocol Timing". This field can only be written in Freeze mode as it is blocked by hardware in other modes.</p> <p>$Sclock\ frequency = PE\ clock\ frequency / (PRESDIV + 1)$</p>
23–22 RJW	<p>Resync Jump Width</p> <p>This 2-bit field defines the maximum number of time quanta that a bit time can be changed by one re-synchronization. (One time quantum is equal to the Sclock period.) The valid programmable values are 0–3. This field can only be written in Freeze mode as it is blocked by hardware in other modes.</p> <p>$Resync\ Jump\ Width = RJW + 1.$</p>
21–19 PSEG1	<p>Phase Segment 1</p> <p>This 3-bit field defines the length of Phase Buffer Segment 1 in the bit time. The valid programmable values are 0–7. This field can only be written in Freeze mode as it is blocked by hardware in other modes.</p> <p>$Phase\ Buffer\ Segment\ 1 = (PSEG1 + 1) \times Time-Quanta.$</p>
18–16 PSEG2	<p>Phase Segment 2</p>

Table continues on the next page...

CANx_CTRL1 field descriptions (continued)

Field	Description
	This 3-bit field defines the length of Phase Buffer Segment 2 in the bit time. The valid programmable values are 1–7. This field can only be written in Freeze mode as it is blocked by hardware in other modes. Phase Buffer Segment 2 = (PSEG2 + 1) x Time-Quanta.
15 BOFFMSK	<p>Bus Off Mask</p> <p>This bit provides a mask for the Bus Off Interrupt.</p> <p>0 Bus Off interrupt disabled 1 Bus Off interrupt enabled</p>
14 ERRMSK	<p>Error Mask</p> <p>This bit provides a mask for the Error Interrupt.</p> <p>0 Error interrupt disabled 1 Error interrupt enabled</p>
13 CLKSRC	<p>CAN Engine Clock Source</p> <p>This bit selects the clock source to the CAN Protocol Engine (PE) to be either the peripheral clock (driven by the PLL) or the crystal oscillator clock. The selected clock is the one fed to the prescaler to generate the Serial Clock (Sclck). In order to guarantee reliable operation, this bit can only be written in Disable mode as it is blocked by hardware in other modes. See Section "Protocol Timing".</p> <p>0 The CAN engine clock source is the oscillator clock. Under this condition, the oscillator clock frequency must be lower than the bus clock. 1 The CAN engine clock source is the peripheral clock.</p>
12 LPB	<p>Loop Back Mode</p> <p>This bit configures FlexCAN to operate in Loop-Back Mode. In this mode, FlexCAN performs an internal loop back that can be used for self test operation. The bit stream output of the transmitter is fed back internally to the receiver input. The Rx CAN input pin is ignored and the Tx CAN output goes to the recessive state (logic '1'). FlexCAN behaves as it normally does when transmitting, and treats its own transmitted message as a message received from a remote node. In this mode, FlexCAN ignores the bit sent during the ACK slot in the CAN frame acknowledge field, generating an internal acknowledge bit to ensure proper reception of its own message. Both transmit and receive interrupts are generated. This bit can only be written in Freeze mode as it is blocked by hardware in other modes.</p> <p>NOTE: In this mode, the MCR[SRXDIS] cannot be asserted because this will impede the self reception of a transmitted message.</p> <p>0 Loop Back disabled 1 Loop Back enabled</p>
11 TWRNMSK	<p>Tx Warning Interrupt Mask</p> <p>This bit provides a mask for the Tx Warning Interrupt associated with the TWRNINT flag in the Error and Status Register. This bit is read as zero when MCR[WRNEN] bit is negated. This bit can only be written if MCR[WRNEN] bit is asserted.</p> <p>0 Tx Warning Interrupt disabled 1 Tx Warning Interrupt enabled</p>
10 RWRNMSK	Rx Warning Interrupt Mask

Table continues on the next page...

CANx_CTRL1 field descriptions (continued)

Field	Description
	<p>This bit provides a mask for the Rx Warning Interrupt associated with the RWRNINT flag in the Error and Status Register. This bit is read as zero when MCR[WRNEN] bit is negated. This bit can only be written if MCR[WRNEN] bit is asserted.</p> <p>0 Rx Warning Interrupt disabled 1 Rx Warning Interrupt enabled</p>
9–8 Reserved	This read-only field is reserved and always has the value zero.
7 SMP	<p>CAN Bit Sampling</p> <p>This bit defines the sampling mode of CAN bits at the Rx input. This bit can only be written in Freeze mode as it is blocked by hardware in other modes.</p> <p>0 Just one sample is used to determine the bit value. 1 Three samples are used to determine the value of the received bit: the regular one (sample point) and 2 preceding samples; a majority rule is used.</p>
6 BOFFREC	<p>Bus Off Recovery</p> <p>This bit defines how FlexCAN recovers from Bus Off state. If this bit is negated, automatic recovering from Bus Off state occurs according to the CAN Specification 2.0B. If the bit is asserted, automatic recovering from Bus Off is disabled and the module remains in Bus Off state until the bit is negated by the user. If the negation occurs before 128 sequences of 11 recessive bits are detected on the CAN bus, then Bus Off recovery happens as if the BOFFREC bit had never been asserted. If the negation occurs after 128 sequences of 11 recessive bits occurred, then FlexCAN will re-synchronize to the bus by waiting for 11 recessive bits before joining the bus. After negation, the BOFFREC bit can be re-asserted again during Bus Off, but it will only be effective the next time the module enters Bus Off. If BOFFREC was negated when the module entered Bus Off, asserting it during Bus Off will not be effective for the current Bus Off recovery.</p> <p>0 Automatic recovering from Bus Off state enabled, according to CAN Spec 2.0 part B 1 Automatic recovering from Bus Off state disabled</p>
5 TSYN	<p>Timer Sync</p> <p>This bit enables a mechanism that resets the free-running timer each time a message is received in Message Buffer 0. This feature provides means to synchronize multiple FlexCAN stations with a special “SYNC” message (i.e., global network time). If the RFEN bit in MCR is set (Rx FIFO enabled), the first available Mailbox, according to CTRL2[RFFN] setting, is used for timer synchronization instead of MB0. This bit can only be written in Freeze mode as it is blocked by hardware in other modes.</p> <p>0 Timer Sync feature disabled 1 Timer Sync feature enabled</p>
4 LBUF	<p>Lowest Buffer Transmitted First</p> <p>This bit defines the ordering mechanism for Message Buffer transmission. When asserted, the LPRIEN bit does not affect the priority arbitration. This bit can only be written in Freeze mode as it is blocked by hardware in other modes.</p> <p>0 Buffer with highest priority is transmitted first. 1 Lowest number buffer is transmitted first.</p>
3 LOM	Listen-Only Mode

Table continues on the next page...

CANx_CTRL1 field descriptions (continued)

Field	Description
	<p>This bit configures FlexCAN to operate in Listen-Only Mode. In this mode, transmission is disabled, all error counters are frozen and the module operates in a CAN Error Passive mode. Only messages acknowledged by another CAN station will be received. If FlexCAN detects a message that has not been acknowledged, it will flag a BIT0 error (without changing the REC), as if it was trying to acknowledge the message.</p> <p>Listen-Only Mode acknowledgement can be obtained by the state of ESR1[FLTCONF] field which is Passive Error when Listen-Only Mode is entered. There can be some delay between the Listen-Only Mode request and acknowledge.</p> <p>This bit can only be written in Freeze mode as it is blocked by hardware in other modes.</p> <p>0 Listen-Only Mode is deactivated. 1 FlexCAN module operates in Listen-Only Mode.</p>
2-0 PROPSEG	<p>Propagation Segment</p> <p>This 3-bit field defines the length of the Propagation Segment in the bit time. The valid programmable values are 0-7. This field can only be written in Freeze mode as it is blocked by hardware in other modes.</p> <p>Propagation Segment Time = (PROPSEG + 1) * Time-Quanta. Time-Quantum = one Sclck period.</p>

44.3.4 Free Running Timer (CANx_TIMER)

This register represents a 16-bit free running counter that can be read and written by the CPU. The timer starts from 0x0 after Reset, counts linearly to 0xFFFF, and wraps around.

The timer is clocked by the FlexCAN bit-clock (which defines the baud rate on the CAN bus). During a message transmission/reception, it increments by one for each bit that is received or transmitted. When there is no message on the bus, it counts using the previously programmed baud rate. The timer is not incremented during Disable, Doze, Stop and Freeze Modes.

The timer value is captured when the second bit of the identifier field of any frame is on the CAN bus. This captured value is written into the Time Stamp entry in a message buffer after a successful reception or transmission of a message.

If bit CTRL1[TSYN] is asserted the Timer is reset whenever a message is received in the first available Mailbox, according to CTRL2[RFFN] setting.

The CPU can write to this register anytime. However, if the write occurs at the same time that the Timer is being reset by a reception in the first Mailbox, then the write value is discarded.

Reading this register affects the Mailbox Unlocking procedure; see Section "Message Buffer Lock Mechanism".

Addresses: CAN0_TIMER is 4002_4000h base + 8h offset = 4002_4008h
 CAN1_TIMER is 400A_4000h base + 8h offset = 400A_4008h

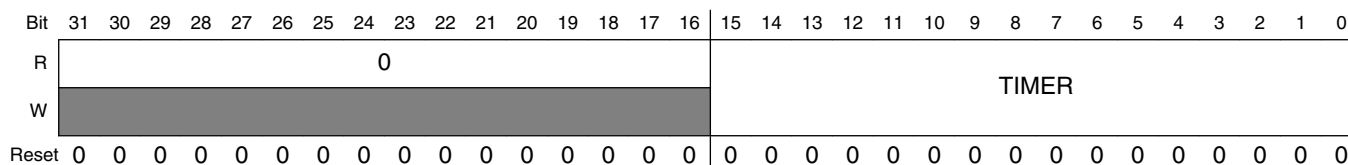

CANx_TIMER field descriptions

Field	Description
31–16 Reserved	This read-only field is reserved and always has the value zero.
15–0 TIMER	Timer value Contains the free-running counter value.

44.3.5 Rx Mailboxes Global Mask Register (CANx_RXMGMASK)

This register is located in RAM.

RXMGMASK is provided for legacy support.

- When the MCR[IRMQ] bit is negated, RXMGMASK is always in effect.
- When the MCR[IRMQ] bit is asserted, RXMGMASK has no effect.

RXMGMASK is used to mask the filter fields of all Rx MBs, excluding MBs 14-15, which have individual mask registers.

This register can only be written in Freeze mode as it is blocked by hardware in other modes.

Addresses: CAN0_RXMGMASK is 4002_4000h base + 10h offset = 4002_4010h
 CAN1_RXMGMASK is 400A_4000h base + 10h offset = 400A_4010h

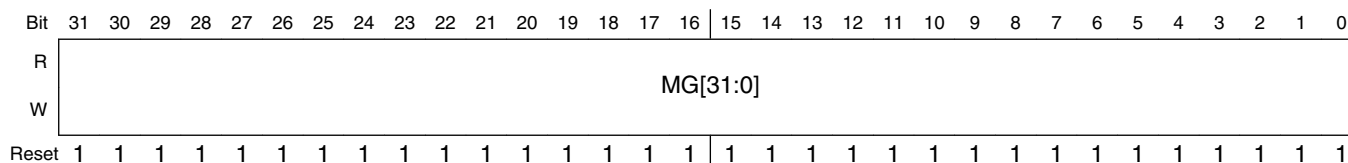

CANx_RXMGMASK field descriptions

Field	Description
31–0 MG[31:0]	Rx Mailboxes Global Mask Bits

CANx_RXMGMASK field descriptions (continued)

Field	Description																																																			
	<p>These bits mask the Mailbox filter bits. Note that the alignment with the ID word of the Mailbox is not perfect as the two most significant MG bits affect the fields RTR and IDE, which are located in the Control and Status word of the Mailbox. The following table shows in detail which MG bits mask each Mailbox filter field.</p> <table border="1"> <thead> <tr> <th rowspan="2">SMB[RTR]¹</th> <th rowspan="2">CTRL2[RRS]</th> <th rowspan="2">CTRL2[EACEN]</th> <th colspan="4">Mailbox filter fields</th> </tr> <tr> <th>MB[RTR]</th> <th>MB[IDE]</th> <th>MB[ID]</th> <th>Reserved</th> </tr> </thead> <tbody> <tr> <td>0</td> <td>-</td> <td>0</td> <td>note²</td> <td>note³</td> <td>MG[28:0]</td> <td>MG[31:29]</td> </tr> <tr> <td>0</td> <td>-</td> <td>1</td> <td>MG[31]</td> <td>MG[30]</td> <td>MG[28:0]</td> <td>MG[29]</td> </tr> <tr> <td>1</td> <td>0</td> <td>-</td> <td>-</td> <td>-</td> <td>-</td> <td>MG[31:0]</td> </tr> <tr> <td>1</td> <td>1</td> <td>0</td> <td>-</td> <td>-</td> <td>MG[28:0]</td> <td>MG[31:29]</td> </tr> <tr> <td>1</td> <td>1</td> <td>1</td> <td>MG[31]</td> <td>MG[30]</td> <td>MG[28:0]</td> <td>MG[29]</td> </tr> </tbody> </table> <p>1. RTR bit of the Incoming Frame. It is saved into an auxiliary MB called Rx Serial Message Buffer (Rx SMB).</p> <p>2. If the CTRL2[EACEN] bit is negated, the RTR bit of Mailbox is never compared with the RTR bit of the incoming frame.</p> <p>3. If the CTRL2[EACEN] bit is negated, the IDE bit of Mailbox is always compared with the IDE bit of the incoming frame.</p> <p>0 The corresponding bit in the filter is "don't care." 1 The corresponding bit in the filter is checked.</p>						SMB[RTR] ¹	CTRL2[RRS]	CTRL2[EACEN]	Mailbox filter fields				MB[RTR]	MB[IDE]	MB[ID]	Reserved	0	-	0	note ²	note ³	MG[28:0]	MG[31:29]	0	-	1	MG[31]	MG[30]	MG[28:0]	MG[29]	1	0	-	-	-	-	MG[31:0]	1	1	0	-	-	MG[28:0]	MG[31:29]	1	1	1	MG[31]	MG[30]	MG[28:0]	MG[29]
SMB[RTR] ¹	CTRL2[RRS]	CTRL2[EACEN]	Mailbox filter fields																																																	
			MB[RTR]	MB[IDE]	MB[ID]	Reserved																																														
0	-	0	note ²	note ³	MG[28:0]	MG[31:29]																																														
0	-	1	MG[31]	MG[30]	MG[28:0]	MG[29]																																														
1	0	-	-	-	-	MG[31:0]																																														
1	1	0	-	-	MG[28:0]	MG[31:29]																																														
1	1	1	MG[31]	MG[30]	MG[28:0]	MG[29]																																														

1. RTR bit of the Incoming Frame. It is saved into an auxiliary MB called Rx Serial Message Buffer (Rx SMB).
2. If the CTRL2[EACEN] bit is negated, the RTR bit of Mailbox is never compared with the RTR bit of the incoming frame.
3. If the CTRL2[EACEN] bit is negated, the IDE bit of Mailbox is always compared with the IDE bit of the incoming frame.

44.3.6 Rx 14 Mask Register (CANx_RX14MASK)

This register is located in RAM.

RX14MASK is provided for legacy support. When the MCR[IRMQ] bit is asserted, RX14MASK has no effect.

RX14MASK is used to mask the filter fields of Message Buffer 14.

This register can only be programmed while the module is in Freeze Mode as it is blocked by hardware in other modes.

Addresses: CAN0_RX14MASK is 4002_4000h base + 14h offset = 4002_4014h

CAN1_RX14MASK is 400A_4000h base + 14h offset = 400A_4014h

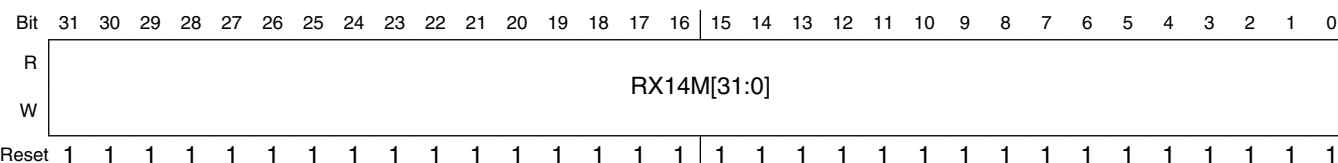

CANx_RX14MASK field descriptions

Field	Description
31–0 RX14M[31:0]	<p>Rx Buffer 14 Mask Bits</p> <p>Each mask bit masks the corresponding Mailbox 14 filter field in the same way that RXMGMASK masks other Mailboxes' filters. See the description of the CAN_RXMGMASK register.</p> <p>0 The corresponding bit in the filter is "don't care." 1 The corresponding bit in the filter is checked.</p>

44.3.7 Rx 15 Mask Register (CANx_RX15MASK)

This register is located in RAM.

RX15MASK is provided for legacy support. When the MCR[IRMQ] bit is asserted, RX15MASK has no effect.

RX15MASK is used to mask the filter fields of Message Buffer 15.

This register can only be programmed while the module is in Freeze Mode as it is blocked by hardware in other modes.

Addresses: CAN0_RX15MASK is 4002_4000h base + 18h offset = 4002_4018h

CAN1_RX15MASK is 400A_4000h base + 18h offset = 400A_4018h

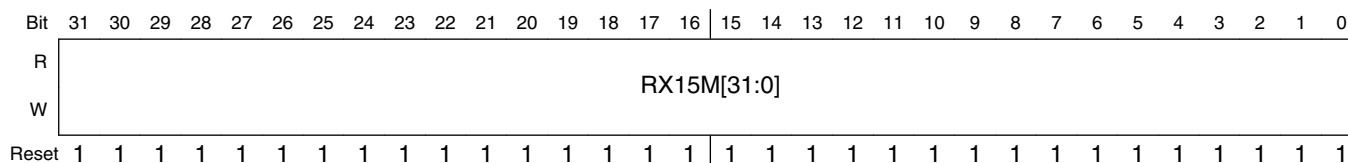

CANx_RX15MASK field descriptions

Field	Description
31–0 RX15M[31:0]	<p>Rx Buffer 15 Mask Bits</p> <p>Each mask bit masks the corresponding Mailbox 15 filter field in the same way that RXMGMASK masks other Mailboxes' filters. See the description of the CAN_RXMGMASK register.</p> <p>0 The corresponding bit in the filter is "don't care." 1 The corresponding bit in the filter is checked.</p>

44.3.8 Error Counter (CANx_ECR)

This register has two 8-bit fields reflecting the value of two FlexCAN error counters: Transmit Error Counter (TXERRCNT field) and Receive Error Counter (RXERRCNT field). The rules for increasing and decreasing these counters are described in the CAN protocol and are completely implemented in the FlexCAN module. Both counters are read-only except in Freeze Mode, where they can be written by the CPU.

FlexCAN responds to any bus state as described in the protocol, e.g. transmit 'Error Active' or 'Error Passive' flag, delay its transmission start time ('Error Passive') and avoid any influence on the bus when in 'Bus Off' state. The following are the basic rules for FlexCAN bus state transitions.

- If the value of TXERRCNT or RXERRCNT increases to be greater than or equal to 128, the FLTCONF field in the Error and Status Register is updated to reflect 'Error Passive' state.
- If the FlexCAN state is 'Error Passive', and either TXERRCNT or RXERRCNT decrements to a value less than or equal to 127 while the other already satisfies this condition, the FLTCONF field in the Error and Status Register is updated to reflect 'Error Active' state.
- If the value of TXERRCNT increases to be greater than 255, the FLTCONF field in the Error and Status Register is updated to reflect 'Bus Off' state, and an interrupt may be issued. The value of TXERRCNT is then reset to zero.
- If FlexCAN is in 'Bus Off' state, then TXERRCNT is cascaded together with another internal counter to count the 128th occurrences of 11 consecutive recessive bits on the bus. Hence, TXERRCNT is reset to zero and counts in a manner where the internal counter counts 11 such bits and then wraps around while incrementing the TXERRCNT. When TXERRCNT reaches the value of 128, the FLTCONF field in the Error and Status Register is updated to be 'Error Active' and both error counters are reset to zero. At any instance of dominant bit following a stream of less than 11 consecutive recessive bits, the internal counter resets itself to zero without affecting the TXERRCNT value.
- If during system start-up, only one node is operating, then its TXERRCNT increases in each message it is trying to transmit, as a result of acknowledge errors (indicated by the ACKERR bit in the Error and Status Register). After the transition to 'Error Passive' state, the TXERRCNT does not increment anymore by acknowledge errors. Therefore the device never goes to the 'Bus Off' state.
- If the RXERRCNT increases to a value greater than 127, it is not incremented further, even if more errors are detected while being a receiver. At the next successful message reception, the counter is set to a value between 119 and 127 to resume to 'Error Active' state.

Addresses: CAN0_ECR is 4002_4000h base + 1Ch offset = 4002_401Ch
 CAN1_ECR is 400A_4000h base + 1Ch offset = 400A_401Ch

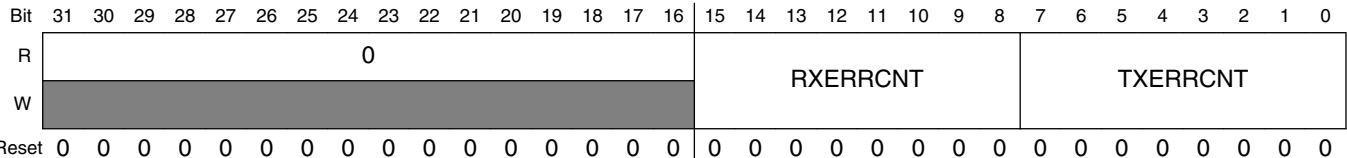

CANx_ECR field descriptions

Field	Description
31-16 Reserved	This read-only field is reserved and always has the value zero.
15-8 RXERRCNT	Receive Error Counter
7-0 TXERRCNT	Transmit Error Counter

44.3.9 Error and Status 1 Register (CANx_ESR1)

This register reflects various error conditions, some general status of the device and it is the source of interrupts to the CPU.

The CPU read action clears bits 15-10, therefore the reported error conditions (bits 15-10) are those that occurred since the last time the CPU read this register. Bits 9-3 are status bits.

The following table shows the FlexCAN state variables and their meanings. Other combinations not shown in the table are reserved.

SYNCH	IDLE	TX	RX	FlexCAN State
0	0	0	0	Not synchronized to CAN bus
1	1	x	x	Idle
1	0	1	0	Transmitting
1	0	0	1	Receiving

memory Map/Register Definition

Addresses: CAN0_ESR1 is 4002_4000h base + 20h offset = 4002_4020h

CAN1_ESR1 is 400A_4000h base + 20h offset = 400A_4020h

Bit	31	30	29	28	27	26	25	24	23	22	21	20	19	18	17	16	
R	0													SYNCH	TWRNINT	RWRNINT	
W															w1c	w1c	
Reset	0	0	0	0	0	0	0	0	0	0	0	0	0	0	0	0	0
Bit	15	14	13	12	11	10	9	8	7	6	5	4	3	2	1	0	
R	BIT1ERR	BIT0ERR	ACKERR	CRCERR	FRMERR	STFERR	TXWRN	RXWRN	IDLE	TX	FLTCONF	RX	BOFFINT	ERRINT	WAKINT		
W													w1c	w1c	w1c		
Reset	0	0	0	0	0	0	0	0	0	0	0	0	0	0	0	0	

CANx_ESR1 field descriptions

Field	Description
31–19 Reserved	This read-only field is reserved and always has the value zero.
18 SYNCH	<p>CAN Synchronization Status</p> <p>This read-only flag indicates whether the FlexCAN is synchronized to the CAN bus and able to participate in the communication process. It is set and cleared by the FlexCAN. See the table in the overall CAN_ESR1 register description.</p> <p>0 FlexCAN is not synchronized to the CAN bus. 1 FlexCAN is synchronized to the CAN bus.</p>
17 TWRNINT	<p>Tx Warning Interrupt Flag</p> <p>If the WRNEN bit in MCR is asserted, the TWRNINT bit is set when the TXWRN flag transitions from '0' to '1', meaning that the Tx error counter reached 96. If the corresponding mask bit in the Control Register (TWRNMSK) is set, an interrupt is generated to the CPU. This bit is cleared by writing it to '1'. When WRNEN is negated, this flag is masked. CPU must clear this flag before disabling the bit. Otherwise it will be set when the WRNEN is set again. Writing '0' has no effect. This flag is not generated during "Bus Off" state. This bit is not updated during Freeze mode.</p> <p>0 No such occurrence 1 The Tx error counter transitioned from less than 96 to greater than or equal to 96.</p>
16 RWRNINT	<p>Rx Warning Interrupt Flag</p> <p>If the WRNEN bit in MCR is asserted, the RWRNINT bit is set when the RXWRN flag transitions from '0' to '1', meaning that the Rx error counters reached 96. If the corresponding mask bit in the Control Register (RWRNMSK) is set, an interrupt is generated to the CPU. This bit is cleared by writing it to '1'. When WRNEN is negated, this flag is masked. CPU must clear this flag before disabling the bit.</p>

Table continues on the next page...

CANx_ESR1 field descriptions (continued)

Field	Description
	<p>Otherwise it will be set when the WRNEN is set again. Writing '0' has no effect. This bit is not updated during Freeze mode.</p> <p>0 No such occurrence 1 The Rx error counter transitioned from less than 96 to greater than or equal to 96.</p>
15 BIT1ERR	<p>Bit1 Error</p> <p>This bit indicates when an inconsistency occurs between the transmitted and the received bit in a message.</p> <p>NOTE: This bit is not set by a transmitter in case of arbitration field or ACK slot, or in case of a node sending a passive error flag that detects dominant bits.</p> <p>0 No such occurrence 1 At least one bit sent as recessive is received as dominant.</p>
14 BIT0ERR	<p>Bit0 Error</p> <p>This bit indicates when an inconsistency occurs between the transmitted and the received bit in a message.</p> <p>0 No such occurrence 1 At least one bit sent as dominant is received as recessive.</p>
13 ACKERR	<p>Acknowledge Error</p> <p>This bit indicates that an Acknowledge Error has been detected by the transmitter node, i.e., a dominant bit has not been detected during the ACK SLOT.</p> <p>0 No such occurrence 1 An ACK error occurred since last read of this register.</p>
12 CRCERR	<p>Cyclic Redundancy Check Error</p> <p>This bit indicates that a CRC Error has been detected by the receiver node, i.e., the calculated CRC is different from the received.</p> <p>0 No such occurrence 1 A CRC error occurred since last read of this register.</p>
11 FRMERR	<p>Form Error</p> <p>This bit indicates that a Form Error has been detected by the receiver node, i.e., a fixed-form bit field contains at least one illegal bit.</p> <p>0 No such occurrence 1 A Form Error occurred since last read of this register.</p>
10 STFERR	<p>Stuffing Error</p> <p>This bit indicates that a Stuffing Error has been detected.</p> <p>0 No such occurrence 1 A Stuffing Error occurred since last read of this register.</p>
9 TXWRN	<p>TX Error Warning</p>

Table continues on the next page...

CANx_ESR1 field descriptions (continued)

Field	Description
	<p>This bit indicates when repetitive errors are occurring during message transmission. This bit is not updated during Freeze mode.</p> <p>0 No such occurrence 1 TXERRCNT is greater than or equal to 96.</p>
8 RXWRN	<p>Rx Error Warning</p> <p>This bit indicates when repetitive errors are occurring during message reception. This bit is not updated during Freeze mode.</p> <p>0 No such occurrence 1 RXERRCNT is greater than or equal to 96.</p>
7 IDLE	<p>This bit indicates when CAN bus is in IDLE state. See the table in the overall CAN_ESR1 register description.</p> <p>0 No such occurrence 1 CAN bus is now IDLE.</p>
6 TX	<p>FlexCAN in Transmission</p> <p>This bit indicates if FlexCAN is transmitting a message. See the table in the overall CAN_ESR1 register description.</p> <p>0 FlexCAN is not transmitting a message. 1 FlexCAN is transmitting a message.</p>
5-4 FLTCONF	<p>Fault Confinement State</p> <p>This 2-bit field indicates the Confinement State of the FlexCAN module.</p> <p>If the LOM bit in the Control Register is asserted, after some delay that depends on the CAN bit timing the FLTCONF field will indicate "Error Passive". The very same delay affects the way how FLTCONF reflects an update to ECR register by the CPU. It may be necessary up to one CAN bit time to get them coherent again.</p> <p>Since the Control Register is not affected by soft reset, the FLTCONF field will not be affected by soft reset if the LOM bit is asserted.</p> <p>00 Error Active 01 Error Passive 1x Bus Off</p>
3 RX	<p>FlexCAN in Reception</p> <p>This bit indicates if FlexCAN is receiving a message. See the table in the overall CAN_ESR1 register description.</p> <p>0 FlexCAN is not receiving a message. 1 FlexCAN is receiving a message.</p>
2 BOFFINT	<p>'Bus Off' Interrupt</p> <p>This bit is set when FlexCAN enters 'Bus Off' state. If the corresponding mask bit in the Control Register (BOFFMSK) is set, an interrupt is generated to the CPU. This bit is cleared by writing it to '1'. Writing '0' has no effect.</p>

Table continues on the next page...

CANx_ESR1 field descriptions (continued)

Field	Description
	0 No such occurrence 1 FlexCAN module entered 'Bus Off' state
1 ERRINT	Error Interrupt This bit indicates that at least one of the Error Bits (bits 15-10) is set. If the corresponding mask bit CTRL1[ERRMSK] is set, an interrupt is generated to the CPU. This bit is cleared by writing it to '1'. Writing '0' has no effect. 0 No such occurrence 1 Indicates setting of any Error Bit in the Error and Status Register
0 WAKINT	Wake-Up Interrupt This field applies when FlexCAN is in low power mode: <ul style="list-style-type: none"> • Doze Mode • Stop Mode When a recessive-to-dominant transition is detected on the CAN bus and if the MCR[WAKMSK] bit is set, an interrupt is generated to the CPU. This bit is cleared by writing it to '1'. When MCR[SLFWAK] is negated, this flag is masked. The CPU must clear this flag before disabling the bit. Otherwise it will be set when the SLFWAK is set again. Writing '0' has no effect. 0 No such occurrence 1 Indicates a recessive to dominant transition was received on the CAN bus

44.3.10 Interrupt Masks 2 Register (CANx_IMASK2)

This register allows any number of a range of 32 Message Buffer Interrupts to be enabled or disabled. It contains one interrupt mask bit per buffer, enabling the CPU to determine which buffer generates an interrupt after a successful transmission or reception (i.e. when the corresponding IFLAG2 bit is set).

Addresses: CAN0_IMASK2 is 4002_4000h base + 24h offset = 4002_4024h

CAN1_IMASK2 is 400A_4000h base + 24h offset = 400A_4024h

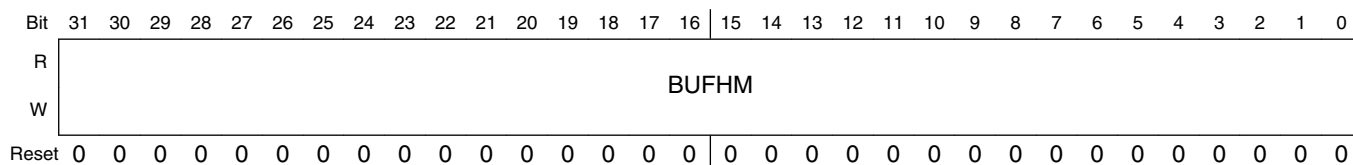

CANx_IMASK2 field descriptions

Field	Description
31–0 BUFHM	Buffer MB _i Mask Each bit enables or disables the corresponding FlexCAN Message Buffer Interrupt. NOTE: Setting or clearing a bit in the IMASK2 Register can assert or negate an interrupt request, if the corresponding IFLAG2 bit is set.

CANx_IMASK2 field descriptions (continued)

Field	Description
0	The corresponding buffer Interrupt is disabled.
1	The corresponding buffer Interrupt is enabled.

44.3.11 Interrupt Masks 1 Register (CANx_IMASK1)

This register allows any number of a range of 32 Message Buffer Interrupts to be enabled or disabled. It contains one interrupt mask bit per buffer, enabling the CPU to determine which buffer generates an interrupt after a successful transmission or reception (i.e. when the corresponding IFLAG1 bit is set).

Addresses: CAN0_IMASK1 is 4002_4000h base + 28h offset = 4002_4028h

CAN1_IMASK1 is 400A_4000h base + 28h offset = 400A_4028h

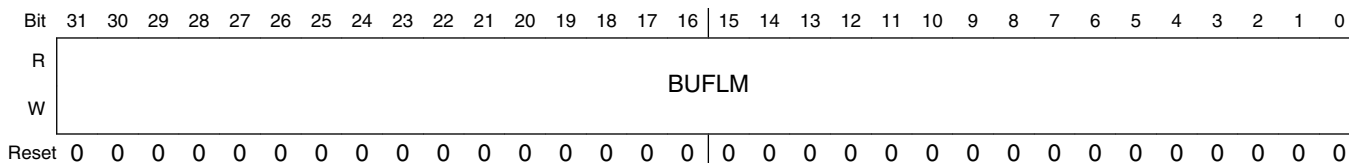

CANx_IMASK1 field descriptions

Field	Description
31–0 BUFLM	<p>Buffer MB; Mask</p> <p>Each bit enables or disables the corresponding FlexCAN Message Buffer Interrupt.</p> <p>NOTE: Setting or clearing a bit in the IMASK1 Register can assert or negate an interrupt request, if the corresponding IFLAG1 bit is set.</p> <p>0 The corresponding buffer Interrupt is disabled.</p> <p>1 The corresponding buffer Interrupt is enabled.</p>

44.3.12 Interrupt Flags 2 Register (CANx_IFLAG2)

This register defines the flags for 32 Message Buffer interrupts. It contains one interrupt flag bit per buffer. Each successful transmission or reception sets the corresponding IFLAG2 bit. If the corresponding IMASK2 bit is set, an interrupt will be generated. The interrupt flag must be cleared by writing 1 to it. Writing 0 has no effect.

Before updating MCR[MAXMB] field, CPU must service the IFLAG2 bits whose MB value is greater than the MCR[MAXMB] to be updated; otherwise, they will remain set and be inconsistent with the amount of MBs available.

Addresses: CAN0_IFLAG2 is 4002_4000h base + 2Ch offset = 4002_402Ch

CAN1_IFLAG2 is 400A_4000h base + 2Ch offset = 400A_402Ch

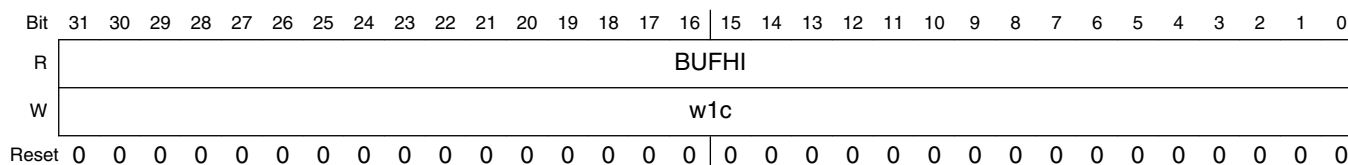

CANx_IFLAG2 field descriptions

Field	Description
31–0 BUFHI	<p>Buffer MB; Interrupt</p> <p>Each bit flags the corresponding FlexCAN Message Buffer interrupt.</p> <p>0 The corresponding buffer has no occurrence of successfully completed transmission or reception.</p> <p>1 The corresponding buffer has successfully completed transmission or reception.</p>

44.3.13 Interrupt Flags 1 Register (CANx_IFLAG1)

This register defines the flags for 32 Message Buffer interrupts. It contains one interrupt flag bit per buffer. Each successful transmission or reception sets the corresponding IFLAG1 bit. If the corresponding IMASK1 bit is set, an interrupt will be generated. The interrupt flag must be cleared by writing 1 to it. Writing 0 has no effect.

The BUF7I to BUF5I flags are also used to represent FIFO interrupts when the Rx FIFO is enabled. When the bit MCR[RFEN] is set the function of the 8 least significant interrupt flags BUF[7:0]I changes: BUF7I, BUF6I and BUF5I indicate operating conditions of the FIFO, and BUF4TO0I are reserved.

Before enabling the RFEN, the CPU must service the IFLAG bits asserted in the Rx FIFO region; see Section "Rx FIFO". Otherwise, these IFLAG bits will mistakenly show the related MBs now belonging to FIFO as having contents to be serviced. When the RFEN bit is negated, the FIFO flags must be cleared. The same care must be taken when an RFFN value is selected extending Rx FIFO filters beyond MB7. For example, when RFFN is 0x8, the MB0-23 range is occupied by Rx FIFO filters and related IFLAG bits must be cleared.

Before updating MCR[MAXMB] field, CPU must service the IFLAG1 bits whose MB value is greater than the MCR[MAXMB] to be updated; otherwise, they will remain set and be inconsistent with the amount of MBs available.

memory Map/Register Definition

Addresses: CAN0_IFLAG1 is 4002_4000h base + 30h offset = 4002_4030h

CAN1_IFLAG1 is 400A_4000h base + 30h offset = 400A_4030h

Bit	31	30	29	28	27	26	25	24	23	22	21	20	19	18	17	16
R	BUF31TO8I[bit 8]															
W	w1c															
Reset	0	0	0	0	0	0	0	0	0	0	0	0	0	0	0	0
Bit	15	14	13	12	11	10	9	8	7	6	5	4	3	2	1	0
R	BUF31TO8I[7:0]								BUF7I	BUF6I	BUF5I	BUF4TO0I				
W	w1c								w1c	w1c	w1c	w1c				
Reset	0	0	0	0	0	0	0	0	0	0	0	0	0	0	0	0

CANx_IFLAG1 field descriptions

Field	Description
31–8 BUF31TO8I	<p>Buffer MB_i Interrupt</p> <p>Each bit flags the corresponding FlexCAN Message Buffer interrupt.</p> <p>0 The corresponding buffer has no occurrence of successfully completed transmission or reception. 1 The corresponding buffer has successfully completed transmission or reception.</p>
7 BUF7I	<p>Buffer MB7 Interrupt or "Rx FIFO Overflow"</p> <p>When the RFEN bit in the MCR is cleared (Rx FIFO disabled), this bit flags the interrupt for MB7.</p> <p>NOTE: This flag is cleared by the FlexCAN whenever the bit MCR[RFEN] is changed by CPU writes. The BUF7I flag represents "Rx FIFO Overflow" when MCR[RFEN] is set. In this case, the flag indicates that a message was lost because the Rx FIFO is full. Note that the flag will not be asserted when the Rx FIFO is full and the message was captured by a Mailbox.</p> <p>0 No occurrence of MB7 completing transmission/reception (when MCR[RFEN]=0) or of Rx FIFO overflow (when MCR[RFEN]=1) 1 MB7 completed transmission/reception (when MCR[RFEN]=0) or Rx FIFO overflow (when MCR[RFEN]=1)</p>
6 BUF6I	<p>Buffer MB6 Interrupt or "Rx FIFO Warning"</p> <p>When the RFEN bit in the MCR is cleared (Rx FIFO disabled), this bit flags the interrupt for MB6.</p> <p>NOTE: This flag is cleared by the FlexCAN whenever the bit MCR[RFEN] is changed by CPU writes. The BUF6I flag represents "Rx FIFO Warning" when MCR[RFEN] is set. In this case, the flag indicates when the number of unread messages within the Rx FIFO is increased to 5 from 4 due to the reception of a new one, meaning that the Rx FIFO is almost full. Note that if the flag is cleared while the number of unread messages is greater than 4, it does not assert again until the number of unread messages within the Rx FIFO is decreased to be equal to or less than 4.</p>

Table continues on the next page...

CANx_IFLAG1 field descriptions (continued)

Field	Description
	<p>0 No occurrence of MB6 completing transmission/reception (when MCR[RFEN]=0) or of Rx FIFO almost full (when MCR[RFEN]=1)</p> <p>1 MB6 completed transmission/reception (when MCR[RFEN]=0) or Rx FIFO almost full (when MCR[RFEN]=1)</p>
5 BUF5I	<p>Buffer MB5 Interrupt or "Frames available in Rx FIFO"</p> <p>When the RFEN bit in the MCR is cleared (Rx FIFO disabled), this bit flags the interrupt for MB5.</p> <p>NOTE: This flag is cleared by the FlexCAN whenever the bit MCR[RFEN] is changed by CPU writes.</p> <p>The BUF5I flag represents "Frames available in Rx FIFO" when MCR[RFEN] is set. In this case, the flag indicates that at least one frame is available to be read from the Rx FIFO.</p> <p>0 No occurrence of MB5 completing transmission/reception (when MCR[RFEN]=0) or of frame(s) available in the Rx FIFO (when MCR[RFEN]=1)</p> <p>1 MB5 completed transmission/reception (when MCR[RFEN]=0) or frame(s) available in the Rx FIFO (when MCR[RFEN]=1)</p>
4–0 BUF4TO0I	<p>Buffer MB_i Interrupt or "reserved"</p> <p>When the RFEN bit in the MCR is cleared (Rx FIFO disabled), these bits flag the interrupts for MB4 to MB0.</p> <p>NOTE: These flags are cleared by the FlexCAN whenever the bit MCR[RFEN] is changed by CPU writes.</p> <p>The BUF4TO0I flags are reserved when MCR[RFEN] is set.</p> <p>0 The corresponding buffer has no occurrence of successfully completed transmission or reception (when MCR[RFEN]=0).</p> <p>1 The corresponding buffer has successfully completed transmission or reception (when MCR[RFEN]=0).</p>

44.3.14 Control 2 Register (CANx_CTRL2)

This register contains control bits for CAN errors, FIFO features, and mode selection.

Addresses: CAN0_CTRL2 is 4002_4000h base + 34h offset = 4002_4034h

CAN1_CTRL2 is 400A_4000h base + 34h offset = 400A_4034h

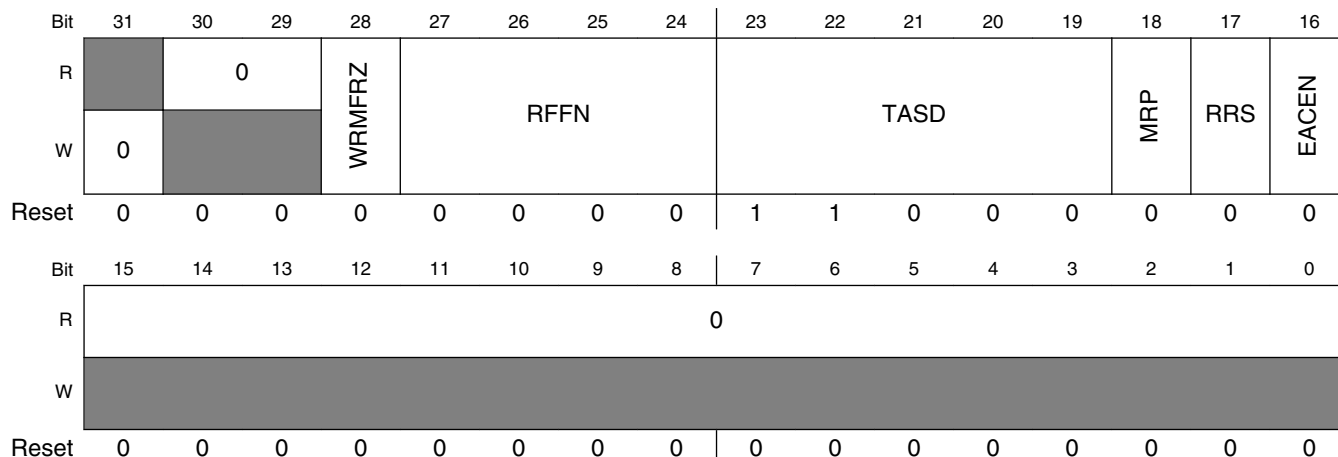

CANx_CTRL2 field descriptions

Field	Description
31 Reserved	This field is reserved.
30-29 Reserved	This read-only field is reserved and always has the value zero.
28 WRMFRZ	<p>Write-Access to Memory in Freeze mode</p> <p>Enable unrestricted write access to FlexCAN memory in Freeze mode. This bit can only be written in Freeze mode and has no effect out of Freeze mode.</p> <p>0 Maintain the write access restrictions. 1 Enable unrestricted write access to FlexCAN memory.</p>
27-24 RFFN	<p>Number of Rx FIFO Filters</p> <p>This 4-bit field defines the number of Rx FIFO filters, as shown in the following table. The maximum selectable number of filters is determined by the MCU. This field can only be written in Freeze mode as it is blocked by hardware in other modes. This field must not be programmed with values that make the number of Message Buffers occupied by Rx FIFO and ID Filter exceed the number of Mailboxes present, defined by MCR[MAXMB].</p> <p>NOTE: Each group of eight filters occupies a memory space equivalent to two Message Buffers which means that the more filters are implemented the less Mailboxes will be available.</p> <p>Considering that the Rx FIFO occupies the memory space originally reserved for MB0-5, RFFN should be programmed with a value corresponding to a number of filters not greater than the number of available memory words which can be calculated as follows:</p> <p>(SETUP_MB - 6) x 4</p> <p>where SETUP_MB is the least between NUMBER_OF_MB and MAXMB.</p>

Table continues on the next page...

CANx_CTRL2 field descriptions (continued)

Field	Description					
	The number of remaining Mailboxes available will be: (SETUP_MB - 8) - (RFFN x 2) If the Number of Rx FIFO Filters programmed through RFFN exceeds the SETUP_MB value (memory space available) the exceeding ones will not be functional.					
	RFFN[3:0]	Number of Rx FIFO filters	Message Buffers occupied by Rx FIFO and ID Filter Table	Remaining Available Mailboxes¹	Rx FIFO ID Filter Table Elements Affected by Rx Individual Masks²	Rx FIFO ID Filter Table Elements Affected by Rx FIFO Global Mask²
	0x0	8	MB 0-7	MB 8-63	Elements 0-7	none
	0x1	16	MB 0-9	MB 10-63	Elements 0-9	Elements 10-15
	0x2	24	MB 0-11	MB 12-63	Elements 0-11	Elements 12-23
	0x3	32	MB 0-13	MB 14-63	Elements 0-13	Elements 14-31
	0x4	40	MB 0-15	MB 16-63	Elements 0-15	Elements 16-39
	0x5	48	MB 0-17	MB 18-63	Elements 0-17	Elements 18-47
	0x6	56	MB 0-19	MB 20-63	Elements 0-19	Elements 20-55
	0x7	64	MB 0-21	MB 22-63	Elements 0-21	Elements 22-63
	0x8	72	MB 0-23	MB 24-63	Elements 0-23	Elements 24-71
	0x9	80	MB 0-25	MB 26-63	Elements 0-25	Elements 26-79
	0xA	88	MB 0-27	MB 28-63	Elements 0-27	Elements 28-87
	0xB	96	MB 0-29	MB 30-63	Elements 0-29	Elements 30-95
	0xC	104	MB 0-31	MB 32-63	Elements 0-31	Elements 32-103
	0xD	112	MB 0-33	MB 34-63	Elements 0-31	Elements 32-111
	0xE	120	MB 0-35	MB 36-63	Elements 0-31	Elements 32-119
	0xF	128	MB 0-37	MB 38-63	Elements 0-31	Elements 32-127
	1. The number of the last remaining available mailboxes is defined by the least value between the parameter NUMBER_OF_MB minus 1 and the MCR[MAXMB] field. 2. If Rx Individual Mask Registers are not enabled then all Rx FIFO filters are affected by the Rx FIFO Global Mask.					
23–19 TASD	<p>Tx Arbitration Start Delay This 5-bit field indicates how many CAN bits the Tx arbitration process start point can be delayed from the first bit of CRC field on CAN bus. This field can only be written in Freeze mode as it is blocked by hardware in other modes.</p> <p>This field is useful to optimize the transmit performance based on factors such as: peripheral/serial clock ratio, CAN bit timing and number of MBs. The duration of an arbitration process, in terms of CAN bits, is directly proportional to the number of available MBs and CAN baud rate and inversely proportional to the peripheral clock frequency.</p> <p>The optimal arbitration timing is that in which the last MB is scanned right before the first bit of the Intermission field of a CAN frame. Therefore, if there are few MBs and the system/serial clock ratio is high and the CAN baud rate is low then the arbitration can be delayed and vice-versa.</p>					

Table continues on the next page...

CANx_CTRL2 field descriptions (continued)

Field	Description
	<p>If T ASD is 0 then the arbitration start is not delayed, thus the CPU has less time to configure a Tx MB for the next arbitration, but more time is reserved for arbitration. In the other hand, if T ASD is 24 then the CPU can configure a Tx MB later and less time is reserved for arbitration.</p> <p>If too little time is reserved for arbitration the FlexCAN may be not able to find winner MBs in time to compete with other nodes for the CAN bus. If the arbitration ends too much time before the first bit of Intermission field then there is a chance that the CPU reconfigures some Tx MBs and the winner MB is not the best to be transmitted.</p> <p>The optimal configuration for T ASD can be calculated as:</p> $T ASD = 25 - \left\{ \frac{f_{CANCLK} \times [MAXB + 3 - (RFEN \times 8) - (RFEN \times RFFN \times 2)] \times 2}{f_{SYS} \times [1 + (PSEG1+1) + (PSEG2+1) + (PROPSEG+1)] \times (PRES DIV+1)} \right\}$ <p>where:</p> <ul style="list-style-type: none"> • f_{CANCLK} is the Protocol Engine (PE) Clock (see section "Protocol Timing"), in Hz; • f_{SYS} is the peripheral clock, in Hz; • MAXMB is the value in CTRL1[MAXMB] field; • RFEN is the value in CTRL1[RFEN] bit; • RFFN is the value in CTRL2[RFFN] field; • PSEG1 is the value in CTRL1[PSEG1] field; • PSEG2 is the value in CTRL1[PSEG2] field; • PROPSEG is the value in CTRL1[PROPSEG] field; • PRES DIV is the value in CTRL1[PRES DIV] field. <p>See Section "Arbitration process" and Section "Protocol Timing" for more details.</p> <p>NOTE: The recommended value for T ASD is 22.</p>
18 MRP	<p>Mailboxes Reception Priority</p> <p>If this bit is set the matching process starts from the Mailboxes and if no match occurs the matching continues on the Rx FIFO. This bit can only be written in Freeze mode as it is blocked by hardware in other modes.</p> <p>0 Matching starts from Rx FIFO and continues on Mailboxes. 1 Matching starts from Mailboxes and continues on Rx FIFO.</p>
17 RRS	<p>Remote Request Storing</p> <p>If this bit is asserted Remote Request Frame is submitted to a matching process and stored in the corresponding Message Buffer in the same fashion of a Data Frame. No automatic Remote Response Frame will be generated.</p> <p>If this bit is negated the Remote Request Frame is submitted to a matching process and an automatic Remote Response Frame is generated if a Message Buffer with CODE=0b1010 is found with the same ID.</p> <p>This bit can only be written in Freeze mode as it is blocked by hardware in other modes.</p> <p>0 Remote Response Frame is generated. 1 Remote Request Frame is stored.</p>
16 EACEN	<p>Entire Frame Arbitration Field Comparison Enable for Rx Mailboxes</p> <p>This bit controls the comparison of IDE and RTR bits within Rx Mailboxes filters with their corresponding bits in the incoming frame by the matching process. This bit does not affect matching for Rx FIFO. This bit can only be written in Freeze mode as it is blocked by hardware in other modes.</p>

Table continues on the next page...

CANx_CTRL2 field descriptions (continued)

Field	Description
0	Rx Mailbox filter's IDE bit is always compared and RTR is never compared despite mask bits.
1	Enables the comparison of both Rx Mailbox filter's IDE and RTR bit with their corresponding bits within the incoming frame. Mask bits do apply.
15–0 Reserved	This read-only field is reserved and always has the value zero.

1. The number of the last remaining available mailboxes is defined by the least value between the parameter NUMBER_OF_MB minus 1 and the MCR[MAXMB] field.
2. If Rx Individual Mask Registers are not enabled then all Rx FIFO filters are affected by the Rx FIFO Global Mask.

44.3.15 Error and Status 2 Register (CANx_ESR2)

This register reflects various interrupt flags and some general status.

Addresses: CAN0_ESR2 is 4002_4000h base + 38h offset = 4002_4038h

CAN1_ESR2 is 400A_4000h base + 38h offset = 400A_4038h

Bit	31	30	29	28	27	26	25	24	23	22	21	20	19	18	17	16
R	0								LPTM							
W	[Greyed out]															
Reset	0	0	0	0	0	0	0	0	0	0	0	0	0	0	0	0
Bit	15	14	13	12	11	10	9	8	7	6	5	4	3	2	1	0
R	0	VPS	IMB	0												
W	[Greyed out]															
Reset	0	0	0	0	0	0	0	0	0	0	0	0	0	0	0	0

CANx_ESR2 field descriptions

Field	Description
31–23 Reserved	This read-only field is reserved and always has the value zero.
22–16 LPTM	Lowest Priority Tx Mailbox If ESR2[VPS] is asserted, this field indicates the lowest number inactive Mailbox (refer to the IMB bit description). If there is no inactive Mailbox then the Mailbox indicated depends on CTRL1[LBUF] bit value. If CTRL1[LBUF] bit is negated then the Mailbox indicated is the one which has the greatest arbitration value (see the "Highest priority Mailbox first" section). If CTRL1[LBUF] bit is asserted then the Mailbox indicated is the highest number active Tx Mailbox. If a Tx Mailbox is being transmitted it is not considered in LPTM calculation. If ESR2[IMB] is not asserted and a frame is transmitted successfully, LPTM is updated with its Mailbox number.
15 Reserved	This read-only field is reserved and always has the value zero.
14 VPS	Valid Priority Status This bit indicates whether IMB and LPTM contents are currently valid or not. VPS is asserted upon every complete Tx arbitration process unless the CPU writes to Control and Status word of a Mailbox that has

Table continues on the next page...

CANx_ESR2 field descriptions (continued)

Field	Description
	<p>already been scanned (i.e. it is behind Tx Arbitration Pointer) during the Tx arbitration process. If there is no inactive Mailbox and only one Tx Mailbox which is being transmitted then VPS is not asserted. VPS is negated upon the start of every Tx arbitration process or upon a write to Control and Status word of any Mailbox.</p> <p>NOTE: ESR2[VPS] is not affected by any CPU write into Control Status (C/S) of a MB which is blocked by abort mechanism. When MCR[AEN] is asserted, the abort code write in C/S of a MB that is being transmitted (pending abort), or any write attempt into a Tx MB with IFLAG set is blocked.</p> <p>0 Contents of IMB and LPTM are invalid. 1 Contents of IMB and LPTM are valid.</p>
13 IMB	<p>Inactive Mailbox</p> <p>If ESR2[VPS] is asserted, this bit indicates whether there is any inactive Mailbox (CODE field is either 0b1000 or 0b0000). This bit is asserted in the following cases:</p> <ul style="list-style-type: none"> • During arbitration, if an LPTM is found and it is inactive. • If IMB is not asserted and a frame is transmitted successfully. <p>This bit is cleared in all start of arbitration (see Section "Arbitration process").</p> <p>NOTE: LPTM mechanism have the following behavior: if an MB is successfully transmitted and ESR2[IMB]=0 (no inactive Mailbox), then ESR2[VPS] and ESR2[IMB] are asserted and the index related to the MB just transmitted is loaded into ESR2[LPTM].</p> <p>0 If ESR2[VPS] is asserted, the ESR2[LPTM] is not an inactive Mailbox. 1 If ESR2[VPS] is asserted, there is at least one inactive Mailbox. LPTM content is the number of the first one.</p>
12–0 Reserved	This read-only field is reserved and always has the value zero.

44.3.16 CRC Register (CANx_CRCCR)

This register provides information about the CRC of transmitted messages.

Addresses: CAN0_CRCCR is 4002_4000h base + 44h offset = 4002_4044h

CAN1_CRCCR is 400A_4000h base + 44h offset = 400A_4044h

Bit	31	30	29	28	27	26	25	24	23	22	21	20	19	18	17	16	15	14	13	12	11	10	9	8	7	6	5	4	3	2	1	0	
R	0								MBCRC								0	TXCRC															
W	0																																
Reset	0	0	0	0	0	0	0	0	0	0	0	0	0	0	0	0	0	0	0	0	0	0	0	0	0	0	0	0	0	0	0	0	0

CANx_CRCCR field descriptions

Field	Description
31–23 Reserved	This read-only field is reserved and always has the value zero.

Table continues on the next page...

CANx_CRCR field descriptions (continued)

Field	Description
22–16 MBCRC	CRC Mailbox This field indicates the number of the Mailbox corresponding to the value in TXCRC field.
15 Reserved	This read-only field is reserved and always has the value zero.
14–0 TXCRC	CRC Transmitted This field indicates the CRC value of the last message transmitted. This field is updated at the same time the Tx Interrupt Flag is asserted.

44.3.17 Rx FIFO Global Mask Register (CANx_RXFGMASK)

This register is located in RAM.

If Rx FIFO is enabled RXFGMASK is used to mask the Rx FIFO ID Filter Table elements that do not have a corresponding RXIMR according to CTRL2[RFFN] field setting.

This register can only be written in Freeze mode as it is blocked by hardware in other modes.

Addresses: CAN0_RXFGMASK is 4002_4000h base + 48h offset = 4002_4048h

CAN1_RXFGMASK is 400A_4000h base + 48h offset = 400A_4048h

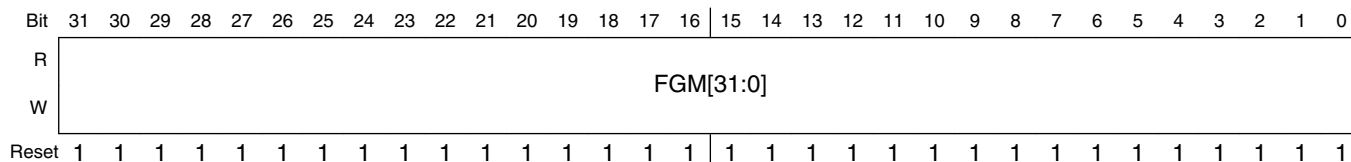

CANx_RXFGMASK field descriptions

Field	Description
31–0 FGM[31:0]	Rx FIFO Global Mask Bits These bits mask the ID Filter Table elements bits in a perfect alignment. The following table shows how the FGM bits correspond to each IDAF field.

CANx_RXFGMASK field descriptions (continued)

Field	Description						
	Rx FIFO ID Filter Table Elements Format (MCR[IDAM])	Identifier Acceptance Filter Fields					Reserved
		RTR	IDE	RXIDA	RXIDB ¹	RXIDC ²	
	A	FGM[31]	FGM[30]	FGM[29:1]	-	-	FGM[0]
	B	FGM[31], FGM[15]	FGM[30], FGM[14]	-	FGM[29:16], FGM[13:0]	-	-
C	-	-	-	-	FGM[31:24], FGM[23:16], FGM[15:8], FGM[7:0]	-	

1. If MCR[IDAM] field is equivalent to the format B only the fourteen most significant bits of the Identifier of the incoming frame are compared with the Rx FIFO filter.
 2. If MCR[IDAM] field is equivalent to the format C only the eight most significant bits of the Identifier of the incoming frame are compared with the Rx FIFO filter.

0 The corresponding bit in the filter is "don't care."
 1 The corresponding bit in the filter is checked.

1. If MCR[IDAM] field is equivalent to the format B only the fourteen most significant bits of the Identifier of the incoming frame are compared with the Rx FIFO filter.
2. If MCR[IDAM] field is equivalent to the format C only the eight most significant bits of the Identifier of the incoming frame are compared with the Rx FIFO filter.

44.3.18 Rx FIFO Information Register (CANx_RXFIR)

RXFIR provides information on Rx FIFO.

This register is the port through which the CPU accesses the output of the RXFIR FIFO located in RAM. The RXFIR FIFO is written by the FlexCAN whenever a new message is moved into the Rx FIFO as well as its output is updated whenever the output of the Rx FIFO is updated with the next message. See Section "Rx FIFO" for instructions on reading this register.

Addresses: CAN0_RXFIR is 4002_4000h base + 4Ch offset = 4002_404Ch

CAN1_RXFIR is 400A_4000h base + 4Ch offset = 400A_404Ch

Bit	31	30	29	28	27	26	25	24	23	22	21	20	19	18	17	16	15	14	13	12	11	10	9	8	7	6	5	4	3	2	1	0
R	0																IDHIT															
W	[Shaded]																															
Reset	x*	x*	x*	x*	x*	x*	x*	x*	x*	x*	x*	x*	x*	x*	x*	x*	x*	x*	x*	x*	x*	x*	x*	x*	x*	x*	x*	x*	x*	x*	x*	x*

* Notes:

- x = Undefined at reset.

CANx_RXFIR field descriptions

Field	Description
31–9 Reserved	This read-only field is reserved and always has the value zero.
8–0 IDHIT	Identifier Acceptance Filter Hit Indicator This field indicates which Identifier Acceptance Filter was hit by the received message that is in the output of the Rx FIFO. If multiple filters match the incoming message ID then the first matching IDAF found (lowest number) by the matching process is indicated. This field is valid only while the IFLAG[BUF5I] is asserted.

44.3.19 Rx Individual Mask Registers (CANx_RXIMR)

These registers are located in RAM.

RXIMR are used as acceptance masks for ID filtering in Rx MBs and the Rx FIFO. If the Rx FIFO is not enabled, one mask register is provided for each available Mailbox, providing ID masking capability on a per Mailbox basis.

When the Rx FIFO is enabled (MCR[RFEN] bit is asserted), up to 32 Rx Individual Mask Registers can apply to the Rx FIFO ID Filter Table elements on a one-to-one correspondence depending on the setting of CTRL2[RFFN].

RXIMR can only be written by the CPU while the module is in Freeze Mode; otherwise, they are blocked by hardware.

The Individual Rx Mask Registers are not affected by reset and must be explicitly initialized prior to any reception.

Addresses: 4002_4000h base + 880h offset + (4d × n), where n = 0d to 15d

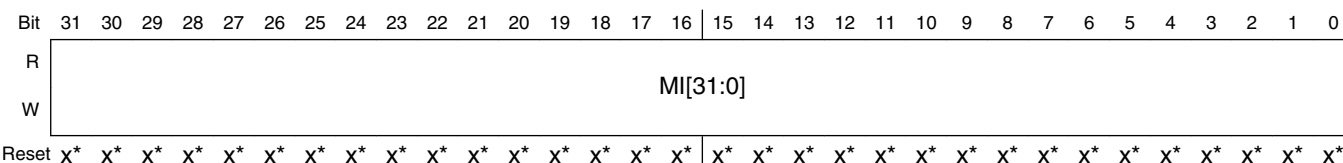

- * Notes:
- x = Undefined at reset.

CANx_RXIMRn field descriptions

Field	Description
31–0 MI[31:0]	Individual Mask Bits Each Individual Mask Bit masks the corresponding bit in both the Mailbox filter and Rx FIFO ID Filter Table element in distinct ways. For Mailbox filters, see the RXMGMASK register description.

CANx_RXIMRn field descriptions (continued)

Field	Description
	For Rx FIFO ID Filter Table elements, see the RXFGMASK register description.
0	The corresponding bit in the filter is "don't care."
1	The corresponding bit in the filter is checked.

44.3.56 Message Buffer Structure

The Message Buffer structure used by the FlexCAN module is represented in the following figure. Both Extended and Standard Frames (29-bit Identifier and 11-bit Identifier, respectively) used in the CAN specification (Version 2.0 Part B) are represented. Each individual MB is formed by 16 bytes.

The memory area from 0x80 to 0x47C is used by the Mailboxes.

Table 44-108. Message Buffer Structure

	31	30	29	28	27	24	23	22	21	20	19	18	17	16	15	8	7	0	
0x0					CODE		SR R	IDE	RT R	DLC			TIME STAMP						
0x4	PRIO			ID (Standard/Extended)						ID (Extended)									
0x8	Data Byte 0				Data Byte 1				Data Byte 2		Data Byte 3								
0xC	Data Byte 4				Data Byte 5				Data Byte 6		Data Byte 7								
					= Unimplemented or Reserved														

CODE — Message Buffer Code

This 4-bit field can be accessed (read or write) by the CPU and by the FlexCAN module itself, as part of the message buffer matching and arbitration process. The encoding is shown in [Table 44-109](#) and [Table 44-110](#). See [Functional Description](#) for additional information.

Table 44-109. Message Buffer Code for Rx buffers

CODE Description	Rx Code BEFORE receive New Frame	SRV ¹	Rx Code AFTER successful reception ²	RRS ³	Comment
0b0000: INACTIVE- MB is not active.	INACTIVE	-	-	-	MB does not participate in the matching process.

Table continues on the next page...

Table 44-109. Message Buffer Code for Rx buffers (continued)

CODE Description	Rx Code BEFORE receive New Frame	SRV ¹	Rx Code AFTER successful reception ²	RRS ³	Comment
0b0100: EMPTY - MB is active and empty.	EMPTY	-	FULL	-	When a frame is received successfully (after move-in process. Refer to Section "Move-in" for details), the CODE field is automatically updated to FULL.
0b0010: FULL - MB is full.	FULL	Yes	FULL	-	The act of reading the C/S word followed by unlocking the MB (SRV) does not make the code return to EMPTY. It remains FULL. If a new frame is moved to the MB after the MB was serviced, the code still remains FULL. Refer to Section "Matching Process" for matching details related to FULL code.
		No	OVERRUN	-	If the MB is FULL and a new frame is moved to this MB before the CPU service it, the CODE field is automatically updated to OVERRUN. Refer to Section "Matching Process" for details about overrun behavior.

Table continues on the next page...

Table 44-109. Message Buffer Code for Rx buffers (continued)

CODE Description	Rx Code BEFORE receive New Frame	SRV ¹	Rx Code AFTER successful reception ²	RRS ³	Comment
0b0110: OVERRUN - MB is being overwritten into a full buffer.	OVERRUN	Yes	FULL	-	If the CODE field indicates OVERRUN and CPU has serviced the MB, when a new frame is moved to the MB, the code returns to FULL.
		No	OVERRUN	-	If the CODE field already indicates OVERRUN, and another new frame must be moved, the MB will be overwritten again, and the code will remain OVERRUN. Refer to Section "Matching Process" for details about overrun behavior.

Table continues on the next page...

Table 44-109. Message Buffer Code for Rx buffers (continued)

CODE Description	Rx Code BEFORE receive New Frame	SRV ¹	Rx Code AFTER successful reception ²	RRS ³	Comment
0b1010: RANSWER ⁴ - A frame was configured to recognize a Remote Request Frame and transmit a Response Frame in return.	RANSWER	-	TANSWER(0b1110)	0	A Remote Answer was configured to recognize a remote request frame received, after that a MB is set to transmit a response frame. The code is automatically changed to TANSWER (0b1110). Refer to Section "Matching Process" for details. If CTRL2[RRS] is negated, transmit a response frame whenever a remote request frame with the same ID is received.
		-	-	1	This code is ignored during matching and arbitration process. Refer to Section "Matching Process" for details.
CODE[0]=1b1: BUSY ⁵ - FlexCAN is updating the contents of the MB. The CPU must not access the MB.	BUSY ⁵	-	FULL	-	Indicates that the MB is being updated, it will be negated automatically and does not interfere on the next CODE.
		-	OVERRUN	-	

1. SRV: Serviced MB. MB was read and unlocked by reading TIMER or other MB.
2. A frame is considered successful reception after the frame to be moved to MB (move-in process). Refer to Section "Move-in" for details)
3. Remote Request Stored bit from CTRL2 register. Refer to Section "Control 2 Register (CTRL2)" for details.
4. Code 0b1010 is not considered Tx and a MB with this code should not be aborted.
5. Note that for Tx MBs, the BUSY bit should be ignored upon read, except when AEN bit is set in the MCR register. If this bit is asserted, the corresponding MB does not participate in the matching process.

Table 44-110. Message Buffer Code for Tx buffers

CODE Description	Tx Code BEFORE tx frame	MBRTR	Tx Code AFTER successful transmission	Comment
0b1000: INACTIVE - MB is not active	INACTIVE	-	-	MB does not participate in the arbitration process.
0b1001: ABORT - MB is aborted	ABORT	-	-	MB does not participate in the arbitration process.
0b1100: DATA - MB is a Tx Data Frame (MB RTR must be 0)	DATA	0	INACTIVE	Transmit data frame unconditionally once. After transmission, the MB automatically returns to the INACTIVE state.
0b1100: REMOTE - MB is a Tx Remote Request Frame (MB RTR must be 1)	REMOTE	1	EMPTY	Transmit remote request frame unconditionally once. After transmission, the MB automatically becomes an Rx Empty MB with the same ID.
0b1110: TANSWER - MB is a Tx Response Frame from an incoming Remote Request Frame	TANSWER	-	RANSWER	This is an intermediate code that is automatically written to the MB by the CHI as a result of match to a remote request frame. The remote response frame will be transmitted unconditionally once and then the code will automatically return to RANSWER (0b1010). The CPU can also write this code with the same effect. The remote response frame can be either a data frame or another remote request frame depending on the RTR bit value. Refer to section "Matching Process" and section "Arbitration Process" for details.

SRR — Substitute Remote Request

Fixed recessive bit, used only in extended format. It must be set to '1' by the user for transmission (Tx Buffers) and will be stored with the value received on the CAN bus for Rx receiving buffers. It can be received as either recessive or dominant. If FlexCAN receives this bit as dominant, then it is interpreted as arbitration loss.

1 = Recessive value is compulsory for transmission in Extended Format frames

0 = Dominant is not a valid value for transmission in Extended Format frames

IDE — ID Extended Bit

This bit identifies whether the frame format is standard or extended.

1 = Frame format is extended

0 = Frame format is standard

RTR — Remote Transmission Request

This bit affects the behavior of Remote Frames and is part of the reception filter. Refer to [Table 44-109](#), [Table 44-110](#) and the description of the RRS bit in Control 2 Register (CTRL2) for additional details.

If FlexCAN transmits this bit as '1' (recessive) and receives it as '0' (dominant), it is interpreted as arbitration loss. If this bit is transmitted as '0' (dominant), then if it is received as '1' (recessive), the FlexCAN module treats it as bit error. If the value received matches the value transmitted, it is considered as a successful bit transmission.

1 = Indicates the current MB may have a Remote Request Frame to be transmitted if MB is Tx. If the MB is Rx then incoming Remote Request Frames may be stored.

0 = Indicates the current MB has a Data Frame to be transmitted.. In Rx MB it may be considered in matching processes.

DLC — Length of Data in Bytes

This 4-bit field is the length (in bytes) of the Rx or Tx data, which is located in offset 0x8 through 0xF of the MB space (see [Table 44-108](#)). In reception, this field is written by the FlexCAN module, copied from the DLC (Data Length Code) field of the received frame. In transmission, this field is written by the CPU and corresponds to the DLC field value of the frame to be transmitted. When RTR=1, the Frame to be transmitted is a Remote Frame and does not include the data field, regardless of the DLC field.

TIME STAMP — Free-Running Counter Time Stamp

This 16-bit field is a copy of the Free-Running Timer, captured for Tx and Rx frames at the time when the beginning of the Identifier field appears on the CAN bus.

PRIO — Local priority

This 3-bit field is only used when LPRIO_EN bit is set in MCR and it only makes sense for Tx mailboxes. These bits are not transmitted. They are appended to the regular ID to define the transmission priority. See [Arbitration process](#).

ID — Frame Identifier

In Standard Frame format, only the 11 most significant bits (28 to 18) are used for frame identification in both receive and transmit cases. The 18 least significant bits are ignored. In Extended Frame format, all bits are used for frame identification in both receive and transmit cases.

DATA BYTE 0-7 — Data Field

Up to eight bytes can be used for a data frame.

For Rx frames, the data is stored as it is received from the CAN bus. DATA BYTE (n) is valid only if n is less than DLC as shown in the table below.

For Tx frames, the CPU prepares the data field to be transmitted within the frame.

Table 44-111. DATA BYTEs validity

DLC	Valid DATA BYTEs
0	none
1	DATA BYTE 0
2	DATA BYTE 0-1
3	DATA BYTE 0-2
4	DATA BYTE 0-3
5	DATA BYTE 0-4
6	DATA BYTE 0-5
7	DATA BYTE 0-6
8	DATA BYTE 0-7

44.3.57 Rx FIFO Structure

When the MCR[RFEN] bit is set, the memory area from 0x80 to 0xDC (which is normally occupied by MBs 0 to 5) is used by the reception FIFO engine.

The region 0x80-0x8C contains the output of the FIFO which must be read by the CPU as a Message Buffer. This output contains the oldest message received and not read yet. The region 0x90-0xDC is reserved for internal use of the FIFO engine.

An additional memory area, that starts at 0xE0 and may extend up to 0x2DC (normally occupied by MBs 6 up to 37) depending on the CTRL2[RFFN] field setting, contains the ID Filter Table (configurable from 8 to 128 table elements) that specifies filtering criteria for accepting frames into the FIFO.

Out of reset, the ID Filter Table flexible memory area defaults to 0xE0 and only extends to 0xFC, which corresponds to MBs 6 to 7 for RFFN=0, for backward compatibility with previous versions of FlexCAN.

The following shows the Rx FIFO data structure.

Table 44-112. Rx FIFO Structure

	31	28	24	23	22	21	20	19	18	17	16	15	8	7	0	
0x80					SRR	IDE	RTR	DLC				TIME STAMP				
0x84	ID Standard								ID Extended							
0x88	Data Byte 0				Data Byte 1				Data Byte 2				Data Byte 3			
0x8C	Data Byte 4				Data Byte 5				Data Byte 6				Data Byte 7			
0x90	Reserved															
to																
0xDC																
0xE0																
0xE4	ID Filter Table Element 1															
0xE8																
to																
0x2D4	ID Filter Table Elements 2 to 125															
0x2D8	ID Filter Table Element 126															
0x2DC	ID Filter Table Element 127															
	= Unimplemented or Reserved															

Each ID Filter Table Element occupies an entire 32-bit word and can be compound by one, two or four Identifier Acceptance Filters (IDAF) depending on the MCR[IDAM] field setting. The following figures show the IDAF indexation.

The following figures show the three different formats of the ID table elements. Note that all elements of the table must have the same format. See [Rx FIFO](#) for more information.

Table 44-113. ID Table structure

Format	31	30	29	24	23	16	15	14	13	8	7	1	0
A	RTR	IDE	RXIDA (Standard = 29-19, Extended = 29-1)										

Table continues on the next page...

Table 44-113. ID Table structure (continued)

B	RTR	IDE	RXIDB_0 (Standard = 29-19, Extended = 29-16)		RTR	IDE	RXIDB_1 (Standard = 13-3, Extended = 13-0)	
	C		RXIDC_0 (Std/Ext = 31-24)	RXIDC_1 (Std/Ext = 23-16)	RXIDC_2 (Std/Ext = 15-8)	RXIDC_3 (Std/Ext = 7-0)		
			= Unimplemented or Reserved					

RTR — Remote Frame

This bit specifies if Remote Frames are accepted into the FIFO if they match the target ID.

1 = Remote Frames can be accepted and data frames are rejected

0 = Remote Frames are rejected and data frames can be accepted

IDE — Extended Frame

Specifies whether extended or standard frames are accepted into the FIFO if they match the target ID.

1 = Extended frames can be accepted and standard frames are rejected

0 = Extended frames are rejected and standard frames can be accepted

RXIDA — Rx Frame Identifier (Format A)

Specifies an ID to be used as acceptance criteria for the FIFO. In the standard frame format, only the 11 most significant bits (29 to 19) are used for frame identification. In the extended frame format, all bits are used.

RXIDB_0, RXIDB_1 — Rx Frame Identifier (Format B)

Specifies an ID to be used as acceptance criteria for the FIFO. In the standard frame format, the 11 most significant bits (a full standard ID) (29 to 19 and 13 to 3) are used for frame identification. In the extended frame format, all 14 bits of the field are compared to the 14 most significant bits of the received ID.

RXIDC_0, RXIDC_1, RXIDC_2, RXIDC_3 — Rx Frame Identifier (Format C)

Specifies an ID to be used as acceptance criteria for the FIFO. In both standard and extended frame formats, all 8 bits of the field are compared to the 8 most significant bits of the received ID.

44.4 Functional Description

The FlexCAN module is a CAN protocol engine with a very flexible mailbox system for transmitting and receiving CAN frames. The mailbox system is composed by a set of up to 64 Message Buffers (MB) that store configuration and control data, time stamp, message ID and data (see [Message Buffer Structure](#)). The memory corresponding to the first 38 MBs can be configured to support a FIFO reception scheme with a powerful ID filtering mechanism, capable of checking incoming frames against a table of IDs (up to 128 extended IDs or 256 standard IDs or 512 8-bit ID slices), with individual mask register for up to 32 ID tables. Simultaneous reception through FIFO and mailbox is supported. For mailbox reception, a matching algorithm makes it possible to store received frames only into MBs that have the same ID programmed on its ID field. A masking scheme makes it possible to match the ID programmed on the MB with a range of IDs on received CAN frames. For transmission, an arbitration algorithm decides the prioritization of MBs to be transmitted based on the message ID (optionally augmented by 3 local priority bits) or the MB ordering.

Before proceeding with the functional description, an important concept must be explained. A Message Buffer is said to be "active" at a given time if it can participate in both the Matching and Arbitration processes. An Rx MB with a 0b0000 code is inactive (refer to [Table 44-109](#)). Similarly, a Tx MB with a 0b1000 or 0b1001 code is also inactive (refer to [Table 44-110](#)).

44.4.1 Transmit Process

In order to transmit a CAN frame, the CPU must prepare a Message Buffer for transmission by executing the following procedure:

1. Check if the respective interrupt bit is set and clear it.
2. If the MB is active (transmission pending), write the ABORT code (0b1001) to the CODE field of the Control and Status word to request an abortion of the transmission. Wait for the corresponding IFLAG to be asserted by polling the IFLAG register or by the interrupt request if enabled by the respective IMASK. Then read back the CODE field to check if the transmission was aborted or transmitted (see [Transmission Abort Mechanism](#)). If backwards compatibility is desired (MCR[AEN] bit is negated), just write the INACTIVE code (0b1000) to the CODE field to inactivate the MB but then the pending frame may be transmitted without notification (see Section "Message Buffer Inactivation").

3. Write the ID word.
4. Write the data bytes.
5. Write the DLC, Control and CODE fields of the Control and Status word to activate the MB.

Once the MB is activated in the fourth step, it will participate into the arbitration process and eventually be transmitted according to its priority. At the end of the successful transmission, the value of the Free Running Timer is written into the Time Stamp field, the CODE field in the Control and Status word is updated, the CRC Register is updated, a status flag is set in the Interrupt Flag Register and an interrupt is generated if allowed by the corresponding Interrupt Mask Register bit. The new CODE field after transmission depends on the code that was used to activate the MB in step four (see [Table 44-109](#) and [Table 44-110](#) in Section [Message Buffer Structure](#)).

When the Abort feature is enabled (MCR[AEN] is asserted), after the Interrupt Flag is asserted for a MB configured as transmit buffer, the MB is blocked, therefore the CPU is not able to update it until the Interrupt Flag is negated by CPU. This means that the CPU must clear the corresponding IFLAG before starting to prepare this MB for a new transmission or reception.

44.4.2 Arbitration process

The arbitration process scans the Mailboxes searching the Tx one that holds the message to be sent in the next opportunity. This Mailbox is called the *arbitration winner*.

The scan starts from the lowest number Mailbox and runs toward the higher ones.

The arbitration process is triggered in the following events:

- From the CRC field of the CAN frame. The start point depends on the CTRL2[TASD] field value.
- During the Error Delimiter field of a CAN frame.
- During the Overload Delimiter field of a CAN frame.
- When the winner is inactivated and the CAN bus has still not reached the first bit of the Intermission field.
- When there is CPU write to the C/S word of a winner MB and the CAN bus has still not reached the first bit of the Intermission field.
- When CHI is in Idle state and the CPU writes to the C/S word of any MB.

- When FlexCAN exits Bus Off state.
- Upon leaving Freeze Mode or Low Power Mode.

If the arbitration process does not manage to evaluate all Mailboxes before the CAN bus has reached the first bit of the Intermission field the temporary arbitration winner is invalidated and the FlexCAN will not compete for the CAN bus in the next opportunity.

The arbitration process selects the winner among the active Tx Mailboxes at the end of the scan according to both CTRL1[LBUF] and MCR[LPRIO_EN] bits settings.

44.4.2.1 Lowest number Mailbox first

If CTRL1[LBUF] bit is asserted the first (lowest number) active Tx Mailbox found is the arbitration winner. MCR[LPRIO_EN] bit has no effect when CTRL1[LBUF] is asserted.

44.4.2.2 Highest priority Mailbox first

If CTRL1[LBUF] bit is negated then the arbitration process searches the active Tx Mailbox with the highest priority, which means that this Mailbox's frame would have a higher probability to win the arbitration on CAN bus with multiple nodes driving each Tx Mailbox's frame at the same time.

The sequence of bits considered for this arbitration is called the *arbitration value* of the Mailbox. The highest priority Tx Mailbox is the one that has the least arbitration value among all Tx Mailboxes.

If two or more Mailboxes have equivalent arbitration values the lowest number Mailbox is the arbitration winner.

The composition of the arbitration value depends on MCR[LPRIO_EN] bit setting.

44.4.2.2.1 Local Priority disabled

If MCR[LPRIO_EN] bit is negated the arbitration value is built in the exact sequence of bits as they would be transmitted in a CAN frame (see the following table) in such a way that the Local Priority is disabled.

Table 44-114. Composition of the arbitration value when Local Priority is disabled

Format	Mailbox Arbitration Value (32 bits)				
Standard (IDE = 0)	Standard ID (11 bits)	RTR (1 bit)	IDE (1 bit)	- (18 bits)	- (1 bit)
Extended (IDE = 1)	Extended ID[28:18] (11 bits)	SRR (1 bit)	IDE (1 bit)	Extended ID[17:0] (18 bits)	RTR (1 bit)

44.4.2.2.2 Local Priority enabled

If Local Priority is desired MCR[LPRIO_EN] must be asserted. In this case the Mailbox PRIO field is included at the very left of the arbitration value (see the following table).

Table 44-115. Composition of the arbitration value when Local Priority is enabled

Format	Mailbox Arbitration Value (35 bits)					
Standard (IDE = 0)	PRIO (3 bits)	Standard ID (11 bits)	RTR (1 bit)	IDE (1 bit)	- (18 bits)	- (1 bit)
Extended (IDE = 1)	PRIO (3 bits)	Extended ID[28:18] (11 bits)	SRR (1 bit)	IDE (1 bit)	Extended ID[17:0] (18 bits)	RTR (1 bit)

As the PRIO field is the most significant part of the arbitration value Mailboxes with low PRIO values have higher priority than Mailboxes with high PRIO values regardless the rest of their arbitration values.

Note that the PRIO field is not part of the frame on the CAN bus. Its purpose is only to affect the internal arbitration process.

44.4.2.3 Arbitration Process (continued)

Once the arbitration winner is found, its content is copied to a hidden auxiliary MB called Tx Serial Message Buffer (Tx SMB), which has the same structure as a normal MB but is not user accessible. This operation is called “move-out” and after it is done, write access to the corresponding MB is blocked (if the AEN bit in MCR is asserted). The write access is released in the following events:

- After the MB is transmitted
- FlexCAN enters in Freeze Mode or Bus Off
- FlexCAN loses the bus arbitration or there is an error during the transmission

At the first opportunity window on the CAN bus, the message on the Tx SMB is transmitted according to the CAN protocol rules. FlexCAN transmits up to eight data bytes, even if the DLC (Data Length Code) field value is greater than that.

Arbitration process can be triggered in the following situations:

- During Rx and Tx frames from CAN CRC field to end of frame. Arbitration start point depends on instantiation parameters NUMBER_OF_MB and T ASD. Additionally, T ASD value may be changed to optimize the arbitration start point.
- During CAN BusOff state from TX_ERR_CNT=124 to 128. Arbitration start point depends on instantiation parameters NUMBER_OF_MB and T ASD. Additionally, T ASD value may be changed to optimize the arbitration start point.
- During C/S write by CPU in BusIdle. First C/S write starts arbitration process and a second C/S write during this same arbitration restarts the process. If other C/S writes are performed, Tx arbitration process is pending. If there is no arbitration winner after arbitration process has finished, then TX arbitration machine begins a new arbitration process.
- • If there is a pending arbitration and BusIdle state starts then an arbitration process is triggered. In this case the first and second C/S write in BusIdle will not restart the arbitration process. It is possible that there is not enough time to finish arbitration in WaitForBusIdle state and the next state is Idle. In this case the scan is not interrupted, and it is completed during BusIdle state. During this arbitration C/S write does not cause arbitration restart.
- Arbitration winner deactivation during a valid arbitration window.
- Upon Leave Freeze Mode (first bit of the WaitForBusIdle state). If there is a re-synchronization during WaitForBusIdle arbitration process is restarted.

Arbitration process stops in the following situation:

- All Mailboxes were scanned.
- A Tx active Mailbox is found in case of Lowest Buffer feature enabled.
- Arbitration winner inactivation or abort during any arbitration process.
- There was not enough time to finish Tx arbitration process. For instance, a deactivation was performed near the end of frame). In this case arbitration process is pending.
- Error or Overload flag in the bus .
- Low Power or Freeze Mode request in Idle state

Arbitration is considered pending as described below:

- It was not possible to finish arbitration process in time.
- C/S write during arbitration if write is performed in a MB which number is lower than the Tx arbitration pointer .
- Any C/S write if there is no Tx Arbitration process in progress.
- Rx Match has just updated a Rx Code to Tx Code.
- Entering Busoff state.

C/S write during arbitration has the following effect:

- If C/S write is performed in the arbitration winner, a new process is restarted immediately.
- If C/S write is performed in a MB whose number is higher than the Tx arbitration pointer, the ongoing arbitration process will scan this MB as normal.

44.4.3 Receive Process

To be able to receive CAN frames into a Mailbox, the CPU must prepare it for reception by executing the following steps:

1. If the Mailbox is active (either Tx or Rx) inactivate the Mailbox (see Section "Message Buffer Inactivation"), preferably with a safe inactivation (see [Transmission Abort Mechanism](#)).
2. Write the ID word
3. Write the EMPTY code (0b0100) to the CODE field of the Control and Status word to activate the Mailbox.

Once the MB is activated, it will be able to receive frames that match the programmed filter. At the end of a successful reception, the Mailbox is updated by the *move-in* process (see Section "Move-in") as follows:

1. The received Data field (8 bytes at most) is stored.
2. The received Identifier field is stored.
3. The value of the Free Running Timer at the time of the second bit of frame's Identifier field is written into the Mailbox's Time Stamp field.
4. The received SRR, IDE, RTR and DLC fields are stored.
5. The CODE field in the Control and Status word is updated (see [Table 44-109](#) and [Table 44-110](#) in Section [Message Buffer Structure](#)).
6. A status flag is set in the Interrupt Flag Register and an interrupt is generated if allowed by the corresponding Interrupt Mask Register bit.

The recommended way for CPU servicing (read) the frame received in an Mailbox is using the following procedure:

1. Read the Control and Status word of that Mailbox.
2. Check if the BUSY bit is deasserted, indicating that the Mailbox is locked. Repeat step 1) while it is asserted. See Section "Message Buffer Lock Mechanism".

3. Read the contents of the Mailbox. Once Mailbox is locked now, its contents won't be modified by FlexCAN Move-in processes. See Section "Move-in".
4. Acknowledge the proper flag at IFLAG registers.
5. Read the Free Running Timer. It is optional but recommended to unlock Mailbox as soon as possible and make it available for reception.

The CPU should synchronize to frame reception by the status flag bit for the specific Mailbox in one of the IFLAG Registers and not by the CODE field of that Mailbox. Polling the CODE field does not work because once a frame was received and the CPU services the Mailbox (by reading the C/S word followed by unlocking the Mailbox), the CODE field will not return to EMPTY. It will remain FULL, as explained in [Table 44-109](#). If the CPU tries to workaround this behavior by writing to the C/S word to force an EMPTY code after reading the Mailbox without a prior *safe inactivation*, a newly received frame matching the filter of that Mailbox may be lost.

CAUTION

In summary: never do polling by reading directly the C/S word of the Mailboxes. Instead, read the IFLAG registers.

Note that the received frame's Identifier field is always stored in the matching Mailbox, thus the contents of the ID field in an Mailbox may change if the match was due to masking. Note also that FlexCAN does receive frames transmitted by itself if there exists a matching Rx Mailbox, provided the MCR[SRXDIS] bit is not asserted. If the MCR[SRXDIS] bit is asserted, FlexCAN will not store frames transmitted by itself in any MB, even if it contains a matching MB, and no interrupt flag or interrupt signal will be generated due to the frame reception.

To be able to receive CAN frames through the Rx FIFO, the CPU must enable and configure the Rx FIFO during Freeze Mode (see [Rx FIFO](#)). Upon receiving the Frames Available in Rx FIFO interrupt (see the description of the IFLAG[BUF5I] "Frames available in Rx FIFO" bit in the IMASK1 register), the CPU should service the received frame using the following procedure:

1. Read the Control and Status word (optional – needed only if a mask was used for IDE and RTR bits)
2. Read the ID field (optional – needed only if a mask was used)
3. Read the Data field
4. Read the RXFIR register (optional)

5. Clear the Frames Available in Rx FIFO interrupt by writing 1 to IFLAG[BUF5I] bit (mandatory – releases the MB and allows the CPU to read the next Rx FIFO entry)

44.4.4 Matching Process

The matching process scans the MB memory looking for Rx MBs programmed with the same ID as the one received from the CAN bus. If the FIFO is enabled, the priority of scanning can be selected between Mailboxes and FIFO filters. In any case, the matching starts from the lowest number Message Buffer toward the higher ones. If no match is found within the first structure then the other is scanned subsequently. In the event that the FIFO is full, the matching algorithm will always look for a matching MB outside the FIFO region.

As the frame is being received, it is stored in a hidden auxiliary MB called Rx Serial Message Buffer (Rx SMB).

The matching process start point depends on the following conditions:

- if the received frame is a remote frame, the start point is the CRC field of the frame;
- if the received frame is a data frame with DLC field equal to zero, the start point is the CRC field of the frame;
- if the received frame is a data frame with DLC field different than zero, the start point is the DATA field of the frame;

If a matching ID is found in the FIFO table or in one of the Mailboxes, the contents of the SMB will be transferred to the FIFO or to the matched Mailbox by the move-in process. If any CAN protocol error is detected then no match results will be transferred to the FIFO or to the matched Mailbox at the end of reception.

The matching process scans all matching elements of both Rx FIFO (if enabled) and active Rx Mailboxes (CODE is EMPTY, FULL, OVERRUN or RANSWER) in search of a successful comparison with the matching elements of the Rx SMB that is receiving the frame on the CAN bus. The SMB has the same structure of a Mailbox. The reception structures (Rx FIFO or Mailboxes) associated with the matching elements that had a successful comparison are the *matched structures*. The *matching winner* is selected at the end of the scan among those matched structures and depends on conditions described ahead. See the following table.

Table 44-116. Matching Architecture

Structure	SMB[RTR]	CTRL2[RRS]	CTRL2[EAC EN]	MB[IDE]	MB[RTR]	MB[ID ¹]	MB[CODE]
Mailbox	0	-	0	cmp ²	no_cmp ³	cmp_msk ⁴	EMPTY or FULL or OVERRUN
Mailbox	0	-	1	cmp_msk	cmp_msk	cmp_msk	EMPTY or FULL or OVERRUN
Mailbox	1	0	-	cmp	no_cmp	cmp	RANSWER
Mailbox	1	1	0	cmp	no_cmp	cmp_msk	EMPTY or FULL or OVERRUN
Mailbox	1	1	1	cmp_msk	cmp_msk	cmp_msk	EMPTY or FULL or OVERRUN
FIFO ⁵	-	-	-	cmp_msk	cmp_msk	cmp_msk	-

1. For Mailbox structure, If SMB[IDE] is asserted, the ID is 29 bits (ID Standard + ID Extended). If SMB[IDE] is negated, the ID is only 11 bits (ID Standard). For FIFO structure, the ID depends on IDAM.
2. cmp: Compares the SMB contents with the MB contents regardless the masks.
3. no_cmp: The SMB contents are not compared with the MB contents
4. cmp_msk: Compares the SMB contents with MB contents taking into account the masks.
5. SMB[IDE] and SMB[RTR] are not taken into account when IDAM is type C.

A reception structure is *free-to-receive* when any of the following conditions is satisfied:

- the CODE field of the Mailbox is EMPTY;
- the CODE field of the Mailbox is either FULL or OVERRUN and it has already been serviced (the C/S word was read by the CPU and unlocked as described in [Message Buffer Lock Mechanism](#));
- the CODE field of the Mailbox is either FULL or OVERRUN and a inactivation (see [Message Buffer Inactivation](#)) is performed;
- the Rx FIFO is not full.

The scan order for Mailboxes and Rx FIFO is from the matching element with lowest number to the higher ones.

The matching winner search for Mailboxes is affected by the MCR[IRMQ] bit. If it is negated the matching winner is the first matched Mailbox regardless if it is free-to-receive or not. If it is asserted, the matching winner is selected according to the priority below:

1. the first free-to-receive matched Mailbox;
2. the last non free-to-receive matched Mailbox.

It is possible to select the priority of scan between Mailboxes and Rx FIFO by the CTRL2[MRP] bit.

If the selected priority is Rx FIFO first:

- if the Rx FIFO is a matched structure and is free-to-receive then the Rx FIFO is the matching winner regardless of the scan for Mailboxes;
- otherwise (the Rx FIFO is not a matched structure or is not free-to-receive), then the matching winner is searched among Mailboxes as described above.

If the selected priority is Mailboxes first:

- if a free-to-receive matched Mailbox is found, it is the matching winner regardless the scan for Rx FIFO;
- if no matched Mailbox is found, then the matching winner is searched in the scan for the Rx FIFO;

If both conditions above are not satisfied and a non free-to-receive matched Mailbox is found then the matching winner determination is conditioned by the MCR[IRMQ] bit:

- if MCR[IRMQ] bit is negated the matching winner is the first matched Mailbox;
- if MCR[IRMQ] bit is asserted the matching winner is the Rx FIFO if it is a free-to-receive matched structure, otherwise the matching winner is the last non free-to-receive matched Mailbox.

See the following table for a summary of matching possibilities.

Table 44-117. Matching Possibilities and Resulting Reception Structures

RFEN	IRMQ	MRP	Matched in MB	Matched in FIFO	Reception Structure	Description
No FIFO, only MB, match is always MB first						
0	0	X ¹	None ²	- ³	None	Frame lost by no match
0	0	X	Free ⁴	-	FirstMB	
0	1	X	None	-	None	Frame lost by no match
0	1	X	Free	-	FirstMb	
0	1	X	NotFree	-	LastMB	Overrun
FIFO enabled, no match in FIFO is as if FIFO does not exist						
1	0	X	None	None ⁵	None	Frame lost by no match
1	0	X	Free	None	FirstMB	
1	1	X	None	None	None	Frame lost by no match
1	1	X	Free	None	FirstMb	
1	1	X	NotFree	None	LastMB	Overrun

Table continues on the next page...

**Table 44-117. Matching Possibilities and Resulting Reception Structures
(continued)**

RFEN	IRMQ	MRP	Matched in MB	Matched in FIFO	Reception Structure	Description
FIFO enabled, Queue disabled						
1	0	0	X	NotFull ⁶	FIFO	
1	0	0	None	Full ⁷	None	Frame lost by FIFO full (FIFO Overflow)
1	0	0	Free	Full	FirstMB	
1	0	0	NotFree	Full	FirstMB	
1	0	1	None	NotFull	FIFO	
1	0	1	None	Full	None	Frame lost by FIFO full (FIFO Overflow)
1	0	1	Free	X	FirstMB	
1	0	1	NotFree	X	FirtsMb	Overrun
FIFO enabled, Queue enabled						
1	1	0	X	NotFull	FIFO	
1	1	0	None	Full	None	Frame lost by FIFO full (FIFO Overflow)
1	1	0	Free	Full	FirstMB	
1	1	0	NotFree	Full	LastMb	Overrun
1	1	1	None	NotFull	FIFO	
1	1	1	Free	X	FirstMB	
1	1	1	NotFree	NotFull	FIFO	
1	1	1	NotFree	Full	LastMb	Overrun

1. This is a don't care condition.
2. Matched in MB "None" means that the frame has not matched any MB (free-to-receive or non-free-to-receive).
3. This is a forbidden condition.
4. Matched in MB "Free" means that the frame matched at least one MB free-to-receive regardless of whether it has matched MBs non-free-to-receive.
5. Matched in FIFO "None" means that the frame has not matched any filter in FIFO. It is as if the FIFO didn't exist (CTRL2[RFEN]=0).
6. Matched in FIFO "NotFull" means that the frame has matched a FIFO filter and has empty slots to receive it.
7. Matched in FIFO "Full" means that the frame has matched a FIFO filter but couldn't store it because it has no empty slots to receive it.

If a non-safe Mailbox inactivation (see [Message Buffer Inactivation](#)) occurs during matching process and the Mailbox inactivated is the temporary matching winner then the temporary matching winner is invalidated. The matching elements scan is not stopped nor restarted, it continues normally. The consequence is that the current matching process works as if the matching elements compared before the inactivation did not exist, therefore a message may be lost.

Suppose, for example, that the FIFO is disabled, IRMQ is enabled and there are two MBs with the same ID, and FlexCAN starts receiving messages with that ID. Let us say that these MBs are the second and the fifth in the array. When the first message arrives, the matching algorithm will find the first match in MB number 2. The code of this MB is EMPTY, so the message is stored there. When the second message arrives, the matching algorithm will find MB number 2 again, but it is not "free-to-receive", so it will keep looking and find MB number 5 and store the message there. If yet another message with the same ID arrives, the matching algorithm finds out that there are no matching MBs that are "free-to-receive", so it decides to overwrite the last matched MB, which is number 5. In doing so, it sets the CODE field of the MB to indicate OVERRUN.

The ability to match the same ID in more than one MB can be exploited to implement a reception queue (in addition to the full featured FIFO) to allow more time for the CPU to service the MBs. By programming more than one MB with the same ID, received messages will be queued into the MBs. The CPU can examine the Time Stamp field of the MBs to determine the order in which the messages arrived.

Matching to a range of IDs is possible by using ID Acceptance Masks. FlexCAN supports individual masking per MB. Refer to the description of the Rx Individual Mask Registers (RXIMRx). During the matching algorithm, if a mask bit is asserted, then the corresponding ID bit is compared. If the mask bit is negated, the corresponding ID bit is "don't care". Please note that the Individual Mask Registers are implemented in RAM, so they are not initialized out of reset. Also, they can only be programmed while the module is in Freeze Mode; otherwise, they are blocked by hardware.

FlexCAN also supports an alternate masking scheme with only four mask registers (RGXMASK, RX14MASK, RX15MASK and RXFGMASK) for backwards compatibility. This alternate masking scheme is enabled when the IRMQ bit in the MCR Register is negated.

44.4.5 Move Process

There are two types of move process: move-in and move-out.

44.4.5.1 Move-in

The move-in process is the copy of a message received by an Rx SMB to a Rx Mailbox or FIFO that has matched it. If the move destination is the Rx FIFO, attributes of the message are also copied to the RXFIR FIFO. Each Rx SMB has its own move-in process,

but only one is performed at a given time as described ahead. The move-in starts only when the message held by the Rx SMB has a corresponding matching winner (see Section "Matching Process") and all of the following conditions are true:

- the CAN bus has reached or let past either:
 - the second bit of Intermission field next to the frame that carried the message that is in the Rx SMB;
 - the first bit of an overload frame next to the frame that carried the message that is in the Rx SMB;
- there is no ongoing matching process;
- the destination Mailbox is not locked by the CPU;
- there is no ongoing move-in process from another Rx SMB. If more than one move-in processes are to be started at the same time both are performed and the newest substitutes the oldest.

The term *pending move-in* is used throughout the document and stands for a move-to-be that still does not satisfy all of the aforementioned conditions.

The move-in is cancelled and the Rx SMB is able to receive another message if any of the following conditions is satisfied:

- the destination Mailbox is inactivated after the CAN bus has reached the first bit of Intermission field next to the frame that carried the message and its matching process has finished;
- there is a previous pending move-in to the same destination Mailbox;
- the Rx SMB is receiving a frame transmitted by the FlexCAN itself and the self-reception is disabled (MCR[SRXDIS] bit is asserted);
- any CAN protocol error is detected.

Note that the pending move-in is not cancelled if the module enters Freeze or Low Power Mode. It only stays on hold waiting for exiting Freeze and Low Power Mode and to be unlocked. If an MB is unlocked during Freeze Mode, the move-in happens immediately.

The move-in process is the execution by the FlexCAN of the following steps:

1. if the message is destined to the Rx FIFO, push IDHIT into the RXFIR FIFO;
2. reads the words DATA0-3 and DATA4-7 from the Rx SMB;
3. writes it in the words DATA0-3 and DATA4-7 of the Rx Mailbox;
4. reads the words Control/Status and ID from the Rx SMB;
5. writes it in the words Control/Status and ID of the Rx Mailbox, updating the CODE field.

The move-in process is not atomic, in such a way that it is immediately cancelled by the inactivation of the destination Mailbox (see Section "Message Buffer Inactivation") and in this case the Mailbox may be left partially updated, thus incoherent. The exception is if the move-in destination is an Rx FIFO Message Buffer, then the process cannot be cancelled.

The BUSY Bit (least significant bit of the CODE field) of the destination Message Buffer is asserted while the move-in is being performed to alert the CPU that the Message Buffer content is temporarily incoherent.

44.4.5.2 Move-out

The move-out process is the copy of the content from a Tx Mailbox to the Tx SMB when a message for transmission is available (see Section "Arbitration process"). The move-out occurs in the following conditions:

- the first bit of Intermission field;
- during Busoff field when TX Error Counter is in the 124 to 128 range;
- during BusIdle field
- during Wait For Bus Idle field

The move-out process is not atomic. Only the CPU has priority to access the memory concurrently out of BusIdle state. In BusIdle, the move-out has the lowest priority to the concurrent memory accesses.

44.4.6 Data Coherence

In order to maintain data coherency and FlexCAN proper operation, the CPU must obey the rules described in [Transmit Process](#) and [Receive Process](#). Any form of CPU accessing an MB structure within FlexCAN other than those specified may cause FlexCAN to behave in an unpredictable way.

44.4.6.1 Transmission Abort Mechanism

The abort mechanism provides a safe way to request the abortion of a pending transmission. A feedback mechanism is provided to inform the CPU if the transmission was aborted or if the frame could not be aborted and was transmitted instead.

Two primary conditions must be fulfilled in order to abort a transmission:

- MCR[AEN] bit must be asserted;
- the first CPU action must be the writing of abort code (0b1001) into the CODE field of the Control and Status word.

The active MBs configured as transmission must be aborted first and then they may be updated. If the abort code is written to a Mailbox that is currently being transmitted, or to a Mailbox that was already loaded into the SMB for transmission, the write operation is blocked and the MB is kept active, but the abort request is captured and kept pending until one of the following conditions are satisfied:

- The module loses the bus arbitration
- There is an error during the transmission
- The module is put into Freeze Mode
- The module enters in BusOff state
- There is an overload frame

If none of conditions above are reached, the MB is transmitted correctly, the interrupt flag is set in the IFLAG register and an interrupt to the CPU is generated (if enabled). The abort request is automatically cleared when the interrupt flag is set. On the other hand, if one of the above conditions is reached, the frame is not transmitted; therefore, the abort code is written into the CODE field, the interrupt flag is set in the IFLAG and an interrupt is (optionally) generated to the CPU.

If the CPU writes the abort code before the transmission begins internally, then the write operation is not blocked; therefore, the MB is updated and the interrupt flag is set. In this way the CPU just needs to read the abort code to make sure the active MB was *safely inactivated*. Although the AEN bit is asserted and the CPU wrote the abort code, in this case the MB is inactivated and not aborted, because the transmission did not start yet. One Mailbox is only aborted when the abort request is captured and kept pending until one of the previous conditions are satisfied.

The abort procedure can be summarized as follows:

- CPU checks the corresponding IFLAG and clears it, if asserted.
- CPU writes 0b1001 into the CODE field of the C/S word.
- CPU waits for the corresponding IFLAG indicating that the frame was either transmitted or aborted.

Functional Description

- CPU reads the CODE field to check if the frame was either transmitted (CODE=0b1000) or aborted (CODE=0b1001).
- It is necessary to clear the corresponding IFLAG in order to allow the MB to be reconfigured.

44.4.6.2 Message Buffer Inactivation

Inactivation is a mechanism provided to protect the Mailbox against updates by the FlexCAN internal processes, thus allowing the CPU to rely on Mailbox data coherence after having updated it, even in Normal Mode.

Inactivation of transmission Mailboxes must be performed just when MCR[AEN] bit is deasserted.

If a Mailbox is inactivated it participates in neither the arbitration process nor the matching process until it is reactivated. See Section "Transmit Process" and Section "Receive Process" for more detailed instruction on how to inactivate and reactivate a Mailbox.

In order to inactivate a Mailbox the CPU must update its CODE field to INACTIVE (either 0b0000 or 0b1000).

As the user is not able to synchronize the CODE field update with the FlexCAN internal processes an inactivation can lead to undesirable results:

- a frame in the bus that matches the filtering of the inactivated Rx Mailbox may be lost without notice, even if there are other Mailboxes with the same filter;
- a frame containing the message within the inactivated Tx Mailbox may be transmitted without notice.

In order to eliminate such risk and perform a *safe inactivation* the CPU must use the following mechanism along with the inactivation itself:

- for Tx Mailboxes, the Transmission Abort (see Section "Transmission Abort Mechanism");

The inactivation automatically unlocks the Mailbox (see Section "Message Buffer Lock Mechanism").

NOTE

Message Buffers that are part of the Rx FIFO cannot be inactivated. There is no write protection on the FIFO region by

FlexCAN. CPU must maintain data coherency in the FIFO region when RFEN is asserted.

44.4.6.3 Message Buffer Lock Mechanism

Besides MB inactivation, FlexCAN has another data coherence mechanism for the receive process. When the CPU reads the Control and Status word of an Rx MB with codes FULL or OVERRUN, FlexCAN assumes that the CPU wants to read the whole MB in an atomic operation, and thus it sets an internal lock flag for that MB. The lock is released when the CPU reads the Free Running Timer (global unlock operation), or when it reads the Control and Status word of another MB regardless of its code, or when the CPU writes into C/S word from locked MB. The MB locking is done to prevent a new frame to be written into the MB while the CPU is reading it.

NOTE

The locking mechanism only applies to Rx MBs that are not part of FIFO and have a code different than INACTIVE (0b0000) or EMPTY¹ (0b0100). Also, Tx MBs can not be locked.

Suppose, for example, that the FIFO is disabled and the second and the fifth MBs of the array are programmed with the same ID, and FlexCAN has already received and stored messages into these two MBs. Suppose now that the CPU decides to read MB number 5 and at the same time another message with the same ID is arriving. When the CPU reads the Control and Status word of MB number 5, this MB is locked. The new message arrives and the matching algorithm finds out that there are no "free-to-receive" MBs, so it decides to override MB number 5. However, this MB is locked, so the new message can not be written there. It will remain in the SMB waiting for the MB to be unlocked, and only then will be written to the MB. If the MB is not unlocked in time and yet another new message with the same ID arrives, then the new message overwrites the one on the SMB and there will be no indication of lost messages either in the CODE field of the MB or in the Error and Status Register.

While the message is being moved-in from the SMB to the MB, the BUSY bit on the CODE field is asserted. If the CPU reads the Control and Status word and finds out that the BUSY bit is set, it should defer accessing the MB until the BUSY bit is negated.

Note

If the BUSY bit is asserted or if the MB is empty, then reading the Control and Status word does not lock the MB.

1. In previous FlexCAN versions, reading the C/S word locked the MB even if it was EMPTY. This behavior is maintained when the IRMQ bit is negated.

Inactivation takes precedence over locking. If the CPU inactivates a locked Rx MB, then its lock status is negated and the MB is marked as invalid for the current matching round. Any pending message on the SMB will not be transferred anymore to the MB. An MB is unlocked when the CPU reads the Free Running Timer Register (see Section "Free Running Timer Register (TIMER)"), or the C/S word of another MB.

Lock and unlock mechanisms have the same functionality in both Normal and Freeze modes.

An unlock during Normal or Freeze mode results in the move-in of the pending message. However, the move-in is postponed if an unlock occurs during any of the low power modes (see in Section "Modes of Operation" specific information on Module Disable, Doze or Stop modes) and it will take place only when the module resumes to Normal or Freeze modes.

44.4.7 Rx FIFO

The receive-only FIFO is enabled by asserting the RFEN bit in the MCR. The reset value of this bit is zero to maintain software backward compatibility with previous versions of the module that did not have the FIFO feature. The FIFO is 6-message deep, therefore when the FIFO is enabled, the memory region occupied by the first 6 Message Buffers is reserved for use of the FIFO engine (see [Rx FIFO Structure](#)). The CPU can read the received messages sequentially, in the order they were received, by repeatedly reading a Message Buffer structure at the output of the FIFO.

The IFLAG[BUF5I] (Frames available in Rx FIFO) is asserted when there is at least one frame available to be read from the FIFO. An interrupt is generated if it is enabled by the corresponding mask bit. Upon receiving the interrupt, the CPU can read the message (accessing the output of the FIFO as a Message Buffer) and the RXFIR register and then clear the interrupt. If there are more messages in the FIFO the act of clearing the interrupt updates the output of the FIFO with the next message and update the RXFIR with the attributes of that message, reissuing the interrupt to the CPU. Otherwise, the flag remains negated. The output of the FIFO is only valid whilst the IFLAG[BUF5I] is asserted.

The IFLAG[BUF6I] (Rx FIFO Warning) is asserted when the number of unread messages within the Rx FIFO is increased to 5 from 4 due to the reception of a new one, meaning that the Rx FIFO is almost full. The flag remains asserted until the CPU clears it.

The IFLAG[BUF7I] (Rx FIFO Overflow) is asserted when an incoming message was lost because the Rx FIFO is full. Note that the flag will not be asserted when the Rx FIFO is full and the message was captured by a Mailbox. The flag remains asserted until the CPU clears it.

Clearing one of those three flags does not affect the state of the other two.

An interrupt is generated if an IFLAG bit is asserted and the corresponding mask bit is asserted too.

A powerful filtering scheme is provided to accept only frames intended for the target application, thus reducing the interrupt servicing work load. The filtering criteria is specified by programming a table of up to 128 32-bit registers, according to CTRL2[RFFN] setting, that can be configured to one of the following formats (see also [Rx FIFO Structure](#)):

- Format A: 128 IDAFs (extended or standard IDs including IDE and RTR)
- Format B: 256 IDAFs (standard IDs or extended 14-bit ID slices including IDE and RTR)
- Format C: 512 IDAFs (standard or extended 8-bit ID slices)

Note

A chosen format is applied to all entries of the filter table. It is not possible to mix formats within the table.

Every frame available in the FIFO has a corresponding IDHIT (Identifier Acceptance Filter Hit Indicator) that can be read by accessing the RXFIR register. The RXFIR[IDHIT] field refers to the message at the output of the FIFO and is valid while the IFLAG[BUF5I] flag is asserted. The RXFIR register must be read only before clearing the flag, which guarantees that the information refers to the correct frame within the FIFO.

Up to thirty two elements of the filter table are individually affected by the Individual Mask Registers (RXIMRx), according to the setting of CTRL2[RFFN], allowing very powerful filtering criteria to be defined. If the IRMQ bit is negated, then the FIFO filter table is affected by RXFGMASK.

44.4.8 CAN Protocol Related Features

This section describes the CAN protocol related features.

44.4.8.1 Remote Frames

Remote frame is a special kind of frame. The user can program a mailbox to be a Remote Request Frame by writing the mailbox as Transmit with the RTR bit set to '1'. After the remote request frame is transmitted successfully, the mailbox becomes a Receive Message Buffer, with the same ID as before.

When a remote request frame is received by FlexCAN, it can be treated in three ways, depending on Remote Request Storing (CTRL2[RRS]) and Rx FIFO Enable (MCR[RFEN]) bits:

- If RRS is negated the frame's ID is compared to the IDs of the Transmit Message Buffers with the CODE field 0b1010. If there is a matching ID, then this mailbox frame will be transmitted. Note that if the matching mailbox has the RTR bit set, then FlexCAN will transmit a remote frame as a response. The received remote request frame is not stored in a receive buffer. It is only used to trigger a transmission of a frame in response. The mask registers are not used in remote frame matching, and all ID bits (except RTR) of the incoming received frame should match. In the case that a remote request frame was received and matched a mailbox, this message buffer immediately enters the internal arbitration process, but is considered as normal Tx mailbox, with no higher priority. The data length of this frame is independent of the DLC field in the remote frame that initiated its transmission.
- If RRS is asserted the frame's ID is compared to the IDs of the receive mailboxes with the CODE field 0b0100, 0b0010 or 0b0110. If there is a matching ID, then this mailbox will store the remote frame in the same fashion of a data frame. No automatic remote response frame will be generated. The mask registers are used in the matching process.
- If RFEN is asserted FlexCAN will not generate an automatic response for remote request frames that match the FIFO filtering criteria. If the remote frame matches one of the target IDs, it will be stored in the FIFO and presented to the CPU. Note that for filtering formats A and B, it is possible to select whether remote frames are accepted or not. For format C, remote frames are always accepted (if they match the ID). Remote Request Frames are considered as normal frames, and generate a FIFO overflow when a successful reception occurs and the FIFO is already full.

44.4.8.2 Overload Frames

FlexCAN does transmit overload frames due to detection of following conditions on CAN bus:

- Detection of a dominant bit in the first/second bit of Intermission
- Detection of a dominant bit at the 7th bit (last) of End of Frame field (Rx frames)
- Detection of a dominant bit at the 8th bit (last) of Error Frame Delimiter or Overload Frame Delimiter

44.4.8.3 Time Stamp

The value of the Free Running Timer is sampled at the beginning of the Identifier field on the CAN bus, and is stored at the end of "move-in" in the TIME STAMP field, providing network behavior with respect to time.

Note that the Free Running Timer can be reset upon a specific frame reception, enabling network time synchronization. Refer to the TSYN description in the description of the Control 1 Register (CTRL1).

44.4.8.4 Protocol Timing

The following figure shows the structure of the clock generation circuitry that feeds the CAN Protocol Engine (PE) sub-module. The clock source bit CLKSRC in the CTRL1 Register defines whether the internal clock is connected to the output of a crystal oscillator (Oscillator Clock) or to the Peripheral Clock (generally from a PLL). In order to guarantee reliable operation, the clock source should be selected while the module is in Disable Mode (bit MDIS set in the Module Configuration Register).

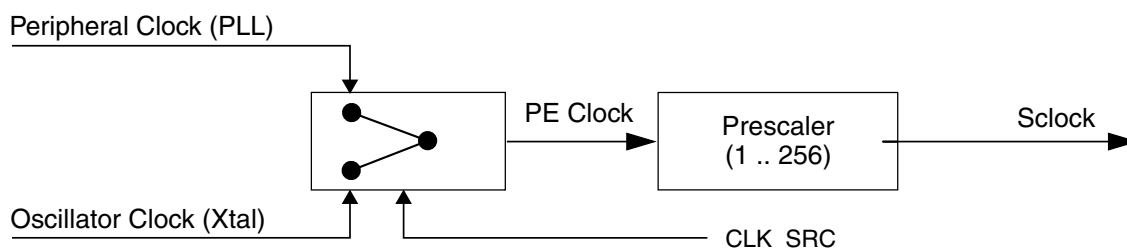

Figure 44-104. CAN Engine Clocking Scheme

The crystal oscillator clock should be selected whenever a tight tolerance (up to 0.1%) is required in the CAN bus timing. The crystal oscillator clock has better jitter performance than PLL generated clocks.

The FlexCAN module supports a variety of means to setup bit timing parameters that are required by the CAN protocol. The Control Register has various fields used to control bit timing parameters: PRES DIV, PROPSEG, PSEG1, PSEG2 and RJW. See the description of the Control 1 Register (CTRL1).

The PRESDIV field controls a prescaler that generates the Serial Clock (Sclock), whose period defines the 'time quantum' used to compose the CAN waveform. A time quantum is the atomic unit of time handled by the CAN engine.

$$f_{Tq} = \frac{f_{CANCLK}}{\text{(Prescaler Value)}}$$

A bit time is subdivided into three segments² (reference [Figure 44-105](#) and [Table 44-118](#)):

- SYNC_SEG: This segment has a fixed length of one time quantum. Signal edges are expected to happen within this section
- Time Segment 1: This segment includes the Propagation Segment and the Phase Segment 1 of the CAN standard. It can be programmed by setting the PROPSEG and the PSEG1 fields of the CTRL1 Register so that their sum (plus 2) is in the range of 4 to 16 time quanta
- Time Segment 2: This segment represents the Phase Segment 2 of the CAN standard. It can be programmed by setting the PSEG2 field of the CTRL1 Register (plus 1) to be 2 to 8 time quanta long

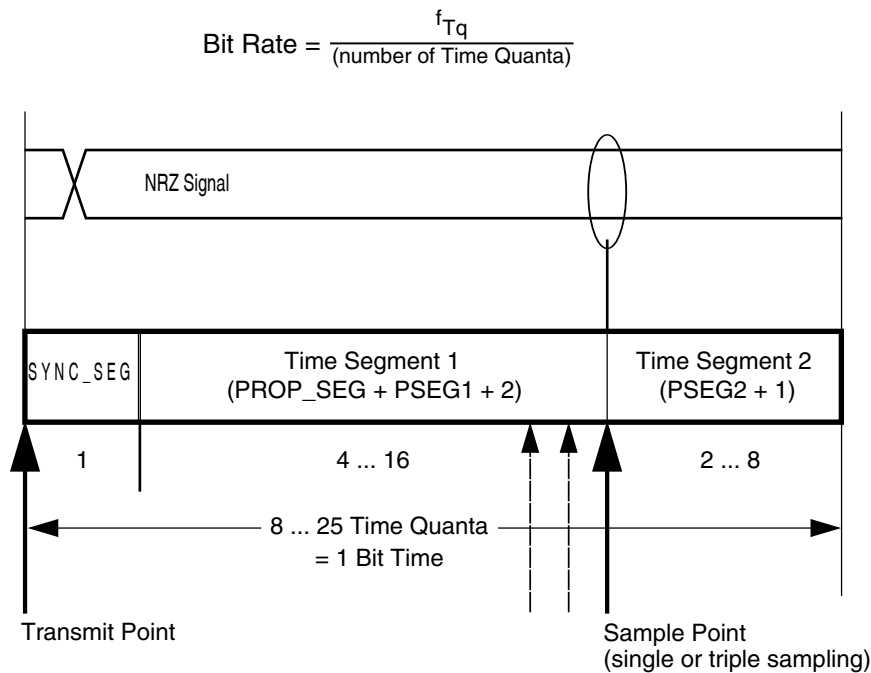

Figure 44-105. Segments within the Bit Time

2. For further explanation of the underlying concepts please refer to ISO/DIS 11519-1, Section 10.3. Reference also the Bosch CAN 2.0A/B protocol specification dated September 1991 for bit timing.

Whenever CAN bit is used as a measure of duration (e.g. MCR[FRZACK] and MCR[LPMACK]), the number of peripheral clocks in one CAN bit can be calculated as:

$$NCCP = \frac{f_{SYS} \times [1 + (PSEG1 + 1) + (PSEG2 + 1) + (PROPSEG + 1)] \times (PRES DIV + 1)}{f_{CANCLK}}$$

where:

- NCCP is the number of peripheral clocks in one CAN bit;
- f_{CANCLK} is the Protocol Engine (PE) Clock (see Figure "CAN Engine Clocking Scheme"), in Hz;
- f_{SYS} is the frequency of operation of the system (CHI) clock, in Hz;
- PSEG1 is the value in CTRL1[PSEG1] field;
- PSEG2 is the value in CTRL1[PSEG2] field;
- PROPSEG is the value in CTRL1[PROPSEG] field;
- PRES DIV is the value in CTRL1[PRES DIV] field.

For example, 180 CAN bits = 180 x NCCP peripheral clock periods.

Table 44-118. Time Segment Syntax

Syntax	Description
SYNC_SEG	System expects transitions to occur on the bus during this period.
Transmit Point	A node in transmit mode transfers a new value to the CAN bus at this point.
Sample Point	A node samples the bus at this point. If the three samples per bit option is selected, then this point marks the position of the third sample.

The following table gives an overview of the CAN compliant segment settings and the related parameter values.

Table 44-119. CAN Standard Compliant Bit Time Segment Settings

Time Segment 1	Time Segment 2	Re-synchronization Jump Width
5 .. 10	2	1 .. 2
4 .. 11	3	1 .. 3
5 .. 12	4	1 .. 4
6 .. 13	5	1 .. 4
7 .. 14	6	1 .. 4
8 .. 15	7	1 .. 4
9 .. 16	8	1 .. 4

Note

It is the user's responsibility to ensure the bit time settings are in compliance with the CAN standard. For bit time calculations, use an IPT (Information Processing Time) of 2, which is the value implemented in the FlexCAN module.

44.4.8.5 Arbitration and Matching Timing

During normal reception and transmission of frames, the matching, arbitration, move-in and move-out processes are executed during certain time windows inside the CAN frame, as shown in the following figures.

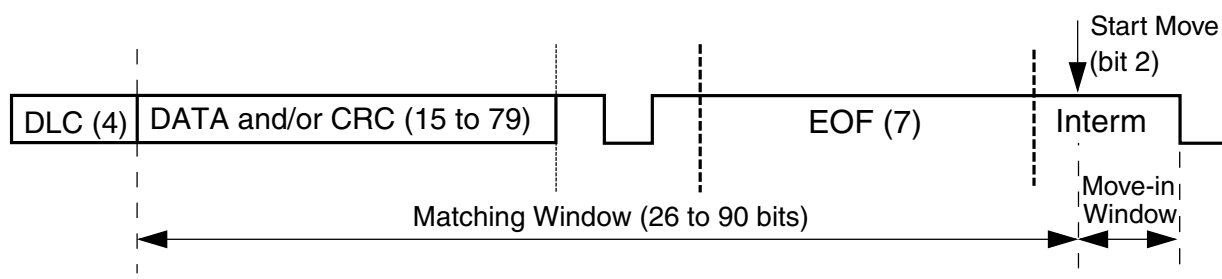

Figure 44-106. Matching and Move-In Time Windows

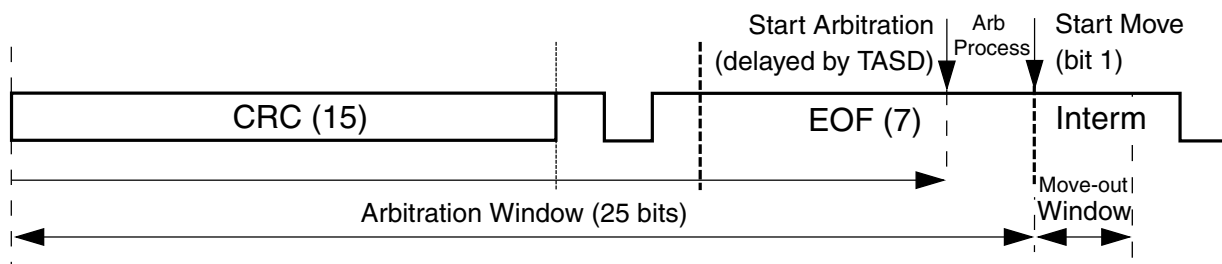

Figure 44-107. Arbitration and Move-Out Time Windows

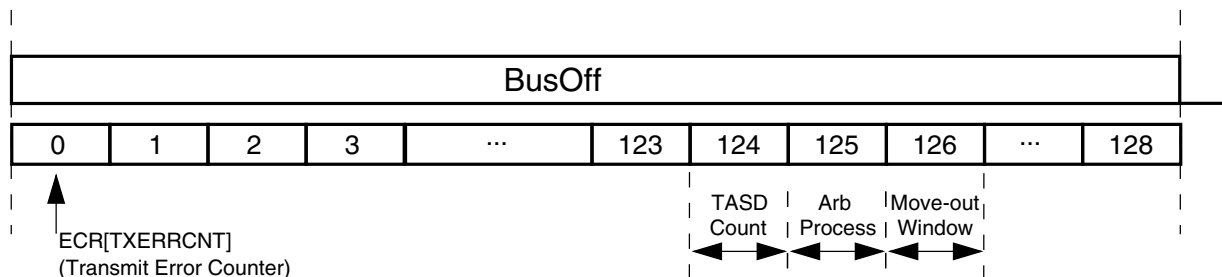

Figure 44-108. Arbitration at the end of Bus Off and Move-Out Time Windows

NOTE

The matching and arbitration timing shown in the preceding figures do not take into account the delay caused by the

concurrent memory access due to the CPU or other internal peripheral.

When doing matching and arbitration, FlexCAN needs to scan the whole Message Buffer memory during the available time slot. In order to have sufficient time to do that, the following requirements must be observed:

- A valid CAN bit timing must be programmed, as indicated in [Table 44-119](#)
- The peripheral clock frequency can not be smaller than the oscillator clock frequency, i.e. the PLL can not be programmed to divide down the oscillator clock; see [Clock domains and restrictions](#)
- There must be a minimum ratio between the peripheral clock frequency and the CAN bit rate, as specified in the following table

Table 44-120. Minimum Ratio Between Peripheral Clock Frequency and CAN Bit Rate

Number of Message Buffers	RFEN	Minimum Number of Peripheral Clocks per CAN bit
16 and 32	0	16
64	0	25
16	1	16
32	1	17
64	1	30

A direct consequence of the first requirement is that the minimum number of time quanta per CAN bit must be 8, so the oscillator clock frequency should be at least 8 times the CAN bit rate. The minimum frequency ratio specified in the preceding table can be achieved by choosing a high enough peripheral clock frequency when compared to the oscillator clock frequency, or by adjusting one or more of the bit timing parameters (PRES DIV, PROPSEG, PSEG1, PSEG2) contained in the Control 1 Register (CTRL1).

In case of synchronous operation (when the peripheral clock frequency is equal to the oscillator clock frequency), the number of peripheral clocks per CAN bit can be adjusted by selecting an adequate value for PRES DIV in order to meet the requirement in the preceding table. In case of asynchronous operation (the peripheral clock frequency greater than the oscillator clock frequency), the number of peripheral clocks per CAN bit can be adjusted by both PRES DIV and/or the frequency ratio.

As an example, taking the case of 64 MBs, if the oscillator and peripheral clock frequencies are equal and the CAN bit timing is programmed to have 8 time quanta per bit, then the prescaler factor (PRES DIV + 1) should be at least 2. For prescaler factor equal to one and CAN bit timing with 8 time quanta per bit, the ratio between peripheral and oscillator clock frequencies should be at least 2.

44.4.9 Modes of Operation Details

The FlexCAN module has four functional modes (Normal Mode, Freeze Mode, Listen-Only Mode and Loop-Back Mode) and three low power modes (Disable Mode, Doze Mode and Stop Mode). See [Modes of Operation](#) for an introductory description of all these modes of operation. The following sub-sections contain functional details on Freeze mode and the low power modes.

CAUTION

“Permanent Dominant” failure on CAN Bus line is not supported by FlexCAN. If a Low Power request or Freeze Mode request is done during a “Permanent Dominant”, the corresponding acknowledge can never be asserted.

44.4.9.1 Freeze Mode

This mode is requested by the CPU through the assertion of the HALT bit in the MCR Register or when the MCU is put into Debug Mode. In both cases it is also necessary that the FRZ bit is asserted in the MCR Register and the module is not in any of the low power modes (Disable, Doze, Stop). The acknowledgement is obtained through the assertion by the FlexCAN of FRZ_ACK bit in the same register. The CPU must only consider the FlexCAN in Freeze Mode when both request and acknowledgement conditions are satisfied.

When Freeze Mode is requested during transmission or reception, FlexCAN does the following:

- Waits to be in either Intermission, Passive Error, Bus Off or Idle state
- Waits for all internal activities like arbitration, matching, move-in and move-out to finish. A pending move-in is not taken into account.
- Ignores the Rx input pin and drives the Tx pin as recessive
- Stops the prescaler, thus halting all CAN protocol activities

- Grants write access to the Error Counters Register, which is read-only in other modes
- Sets the NOT_RDY and FRZ_ACK bits in MCR

After requesting Freeze Mode, the user must wait for the FRZ_ACK bit to be asserted in MCR before executing any other action, otherwise FlexCAN may operate in an unpredictable way. In Freeze mode, all memory mapped registers are accessible, except for CTRL1[CLK_SRC] bit that can be read but cannot be written.

Exiting Freeze Mode is done in one of the following ways:

- CPU negates the FRZ bit in the MCR Register
- The MCU is removed from Debug Mode and/or the HALT bit is negated

The FRZ_ACK bit is negated after the protocol engine recognizes the negation of the freeze request. Once out of Freeze Mode, FlexCAN tries to re-synchronize to the CAN bus by waiting for 11 consecutive recessive bits.

44.4.9.2 Module Disable Mode

This low power mode is normally used to temporarily disable a complete FlexCAN block, with no power consumption. It is requested by the CPU through the assertion of the MDIS bit in the MCR Register and the acknowledgement is obtained through the assertion by the FlexCAN of the LPM_ACK bit in the same register. The CPU must only consider the FlexCAN in Disable Mode when both request and acknowledgement conditions are satisfied.

If the module is disabled during Freeze Mode, it requests to disable the clocks to the PE and CHI sub-modules, sets the LPM_ACK bit and negates the FRZ_ACK bit. If the module is disabled during transmission or reception, FlexCAN does the following:

- Waits to be in either Idle or Bus Off state, or else waits for the third bit of Intermission and then checks it to be recessive
- Waits for all internal activities like arbitration, matching, move-in and move-out to finish. A pending move-in is not taken into account.
- Ignores its Rx input pin and drives its Tx pin as recessive
- Shuts down the clocks to the PE and CHI sub-modules
- Sets the NOTRDY and LPMACK bits in MCR

The Bus Interface Unit continues to operate, enabling the CPU to access memory mapped registers, except the Rx Mailboxes Global Mask Registers, the Rx Buffer 14 Mask Register, the Rx Buffer 15 Mask Register, the Rx FIFO Global Mask Register. The Rx FIFO Information Register, the Message Buffers, the Rx Individual Mask Registers, and the reserved words within RAM may not be accessed when the module is in Disable Mode. Exiting from this mode is done by negating the MDIS bit by the CPU, which causes the FlexCAN to request to resume the clocks and negate the LPM_ACK bit after the CAN protocol engine recognizes the negation of disable mode requested by the CPU.

44.4.9.3 Doze Mode

This is a system low power mode in which the CPU bus is kept alive and a global Doze Mode request is sent to all peripherals asking them to enter low power mode. When Doze Mode is globally requested, the DOZE bit in MCR Register needs to have been asserted previously for Doze Mode to be triggered. The acknowledgement is obtained through the assertion by the FlexCAN of the LPM_ACK bit in the same register. The CPU must only consider the FlexCAN in Doze Mode when both request and acknowledgement conditions are satisfied.

If Doze Mode is triggered during Freeze Mode, FlexCAN requests to shut down the clocks to the PE and CHI sub-modules, sets the LPM_ACK bit and negates the FRZ_ACK bit. If Doze Mode is triggered during transmission or reception, FlexCAN does the following:

- Waits to be in either Idle or Bus Off state, or else waits for the third bit of Intermission and checks it to be recessive
- Waits for all internal activities like arbitration, matching, move-in and move-out to finish. A pending move-in is not taken into account.
- Ignores its Rx input pin and drives its Tx pin as recessive
- Shuts down the clocks to the PE and CHI sub-modules
- Sets the NOT_RDY and LPM_ACK bits in MCR

The Bus Interface Unit continues to operate, enabling the CPU to access memory mapped registers, except the Rx Mailboxes Global Mask Registers, the Rx Buffer 14 Mask Register, the Rx Buffer 15 Mask Register, the Rx FIFO Global Mask Register. The Rx FIFO Information Register, the Message Buffers, the Rx Individual Mask Registers, and the reserved words within RAM may not be accessed when the module is in Doze Mode.

Exiting Doze Mode is done in one of the following ways:

- CPU removing the Doze Mode request
- CPU negating the DOZE bit of the MCR Register
- Self Wake mechanism

In the Self Wake mechanism, if the SLF_WAK bit in MCR Register was set at the time FlexCAN entered Doze Mode, then upon detection of a recessive to dominant transition on the CAN bus, FlexCAN negates the DOZE bit, requests to resume its clocks and negates the LPM_ACK after the CAN protocol engine recognizes the negation of the Doze Mode request. It also sets the WAK_INT bit in the ESR Register and, if enabled by the WAK_MSK bit in MCR, generates a Wake Up interrupt to the CPU. FlexCAN will then wait for 11 consecutive recessive bits to synchronize to the CAN bus. As a consequence, it will not receive the frame that woke it up. The following table details the effect of SLF_WAK and WAK_MSK upon wake-up from Doze Mode.

Table 44-121. Wake-up from Doze Mode

SLF_WAK	WAK_INT	WAK_MSK	FlexCAN Clocks Enabled	Wake-up Interrupt Generated
0	-	-	No	No
0	-	-	No	No
1	0	0	No	No
1	0	1	No	No
1	1	0	Yes	No
1	1	1	Yes	Yes

44.4.9.4 Stop Mode

This is a system low power mode in which all MCU clocks can be stopped for maximum power savings. The Stop Mode is globally requested by the CPU and the acknowledgement is obtained through the assertion by the FlexCAN of a Stop Acknowledgement signal. The CPU must only consider the FlexCAN in Stop Mode when both request and acknowledgement conditions are satisfied.

If FlexCAN receives the global Stop Mode request during Freeze Mode, it sets the LPM_ACK bit, negates the FRZ_ACK bit and then sends the Stop Acknowledge signal to the CPU, in order to shut down the clocks globally. If Stop Mode is requested during transmission or reception, FlexCAN does the following:

- Waits to be in either Idle or Bus Off state, or else waits for the third bit of Intermission and checks it to be recessive

Functional Description

- Waits for all internal activities like arbitration, matching, move-in and move-out to finish. A pending move-in is not taken into account.
- Ignores its Rx input pin and drives its Tx pin as recessive
- Sets the NOT_RDY and LPM_ACK bits in MCR
- Sends a Stop Acknowledge signal to the CPU, so that it can shut down the clocks globally

Exiting Stop Mode is done in one of the following ways:

- CPU resuming the clocks and removing the Stop Mode request
- CPU resuming the clocks and Stop Mode request as a result of the Self Wake mechanism

In the Self Wake mechanism, if the SLF_WAK bit in MCR Register was set at the time FlexCAN entered Stop Mode, then upon detection of a recessive to dominant transition on the CAN bus, FlexCAN sets the WAK_INT bit in the ESR Register and, if enabled by the WAK_MSK bit in MCR, generates a Wake Up interrupt to the CPU. Upon receiving the interrupt, the CPU should resume the clocks and remove the Stop Mode request. FlexCAN will then wait for 11 consecutive recessive bits to synchronize to the CAN bus. As a consequence, it will not receive the frame that woke it up. The following table details the effect of SLF_WAK and WAK_MSK upon wake-up from Stop Mode. Note that wake-up from Stop Mode only works when both bits are asserted.

After the CAN protocol engine recognizes the negation of the Stop Mode request, the FlexCAN negates the LPM_ACK bit.

Table 44-122. Wake-up from Stop Mode

SLF_WAK	WAK_INT	WAK_MSK	MCU Clocks Enabled	Wake-up Interrupt Generated
0	-	-	No	No
0	-	-	No	No
1	0	0	No	No
1	0	1	No	No
1	1	0	No	No
1	1	1	Yes	Yes

44.4.10 Interrupts

Each one of the message buffers can be an interrupt source, if its corresponding IMASK bit is set. There is no distinction between Tx and Rx interrupts for a particular buffer, under the assumption that the buffer is initialized for either transmission or reception. Each of the buffers has assigned a flag bit in the IFLAG Registers. The bit is set when the corresponding buffer completes a successful transmission/reception and is cleared when the CPU writes it to '1' (unless another interrupt is generated at the same time).

Note

It must be guaranteed that the CPU only clears the bit causing the current interrupt. For this reason, bit manipulation instructions (BSET) must not be used to clear interrupt flags. These instructions may cause accidental clearing of interrupt flags which are set after entering the current interrupt service routine.

If the Rx FIFO is enabled (bit RFEN on MCR set), the interrupts corresponding to MBs 0 to 7 have a different behavior. Bit 7 of the IFLAG1 becomes the "FIFO Overflow" flag; bit 6 becomes the FIFO Warning flag, bit 5 becomes the "Frames Available in FIFO flag" and bits 4-0 are unused. See the description of the Interrupt Flags 1 Register (IFLAG1) for more information.

A combined interrupt for all MBs is generated by an Or of all the interrupt sources from MBs. This interrupt gets generated when any of the MBs or FIFO generates an interrupt. In this case the CPU must read the IFLAG Registers to determine which MB or FIFO caused the interrupt.

The other interrupt sources (Bus Off, Error, Tx Warning, Rx Warning, and Wake Up) generate interrupts like the MB ones, and can be read from both the Error and Status Register 1 and 2. The Bus Off, Error, Tx Warning and Rx Warning interrupt mask bits are located in the Control 1 Register; the Wake-Up interrupt mask bit is located in the MCR.

44.4.11 Bus Interface

The CPU access to FlexCAN registers are subject to the following rules:

- Unrestricted read and write access to supervisor registers (registers identified with S/U in Table "Module Memory Map" in Supervisor Mode or with S only) results in access error.
- Read and write access to implemented reserved address space results in access error.

- Write access to positions whose bits are all currently read-only results in access error. If at least one of the bits is not read-only then no access error is issued. Write permission to positions or some of their bits can change depending on the mode of operation or transitory state. Refer to register and bit descriptions for details.
- Read and write access to unimplemented address space results in access error.
- Read and write access to RAM located positions during Low Power Mode results in access error.
- If MAXMB is programmed with a value smaller than the available number of MBs, then the unused memory space can be used as general purpose RAM space. Note that reserved words within RAM cannot be used. As an example, suppose FlexCAN is configured with 16 MBs, RFFN is 0x0, and MAXMB is programmed with zero. The maximum number of MBs in this case becomes one. The RAM starts at 0x0080, and the space from 0x0080 to 0x008F is used by the one MB. The memory space from 0x0090 to 0x017F is available. The space between 0x0180 and 0x087F is reserved. The space from 0x0880 to 0x0883 is used by the one Individual Mask and the available memory in the Mask Registers space would be from 0x0884 to 0x08BF. From 0x08C0 through 0x09DF there are reserved words for internal use which cannot be used as general purpose RAM. As a general rule, free memory space for general purpose depends only on MAXMB.

Note

Unused MB space must not be used as general purpose RAM while FlexCAN is transmitting and receiving CAN frames.

44.5 Initialization/Application Information

This section provide instructions for initializing the FlexCAN module.

44.5.1 FlexCAN Initialization Sequence

The FlexCAN module may be reset in three ways:

- MCU level hard reset, which resets all memory mapped registers asynchronously
- MCU level soft reset, which resets some of the memory mapped registers synchronously (refer to [Table 44-2](#) to see what registers are affected by soft reset)
- SOFT_RST bit in MCR, which has the same effect as the MCU level soft reset

Soft reset is synchronous and has to follow an internal request/acknowledge procedure across clock domains. Therefore, it may take some time to fully propagate its effects. The `SOFT_RST` bit remains asserted while soft reset is pending, so software can poll this bit to know when the reset has completed. Also, soft reset can not be applied while clocks are shut down in any of the low power modes. The low power mode should be exited and the clocks resumed before applying soft reset.

The clock source (`CLK_SRC` bit) should be selected while the module is in Disable Mode. After the clock source is selected and the module is enabled (`MDIS` bit negated), FlexCAN automatically goes to Freeze Mode. In Freeze Mode, FlexCAN is unsynchronized to the CAN bus, the `HALT` and `FRZ` bits in MCR Register are set, the internal state machines are disabled and the `FRZ_ACK` and `NOT_RDY` bits in the MCR Register are set. The Tx pin is in recessive state and FlexCAN does not initiate any transmission or reception of CAN frames. Note that the Message Buffers and the Rx Individual Mask Registers are not affected by reset, so they are not automatically initialized.

For any configuration change/initialization it is required that FlexCAN is put into Freeze Mode (see [Freeze Mode](#)). The following is a generic initialization sequence applicable to the FlexCAN module:

- Initialize the Module Configuration Register
 - Enable the individual filtering per MB and reception queue features by setting the `IRMQ` bit
 - Enable the warning interrupts by setting the `WRN_EN` bit
 - If required, disable frame self reception by setting the `SRX_DIS` bit
 - Enable the Rx FIFO by setting the `RFEN` bit
 - Enable the abort mechanism by setting the `AEN` bit
 - Enable the local priority feature by setting the `LPRIO_EN` bit
- Initialize the Control Register
 - Determine the bit timing parameters: `PROPSEG`, `PSEG1`, `PSEG2`, `RJW`
 - Determine the bit rate by programming the `PRESDIV` field
 - Determine the internal arbitration mode (`LBUF` bit)
- Initialize the Message Buffers
 - The Control and Status word of all Message Buffers must be initialized

- If Rx FIFO was enabled, the ID filter table must be initialized
- Other entries in each Message Buffer should be initialized as required
- Initialize the Rx Individual Mask Registers
- Set required interrupt mask bits in the IMASK Registers (for all MB interrupts), in CTRL Register (for Bus Off and Error interrupts) and in MCR Register for Wake-Up interrupt
- Negate the HALT bit in MCR

Starting with the last event, FlexCAN attempts to synchronize to the CAN bus.

Chapter 45

SPI (DSPI)

45.1 Introduction

NOTE

For the chip-specific implementation details of this module's instances see the chip configuration chapter.

The serial peripheral interface module provides a synchronous serial bus for communication between an MCU and an external peripheral device.

45.1.1 Block Diagram

The block diagram of this module is as follows:

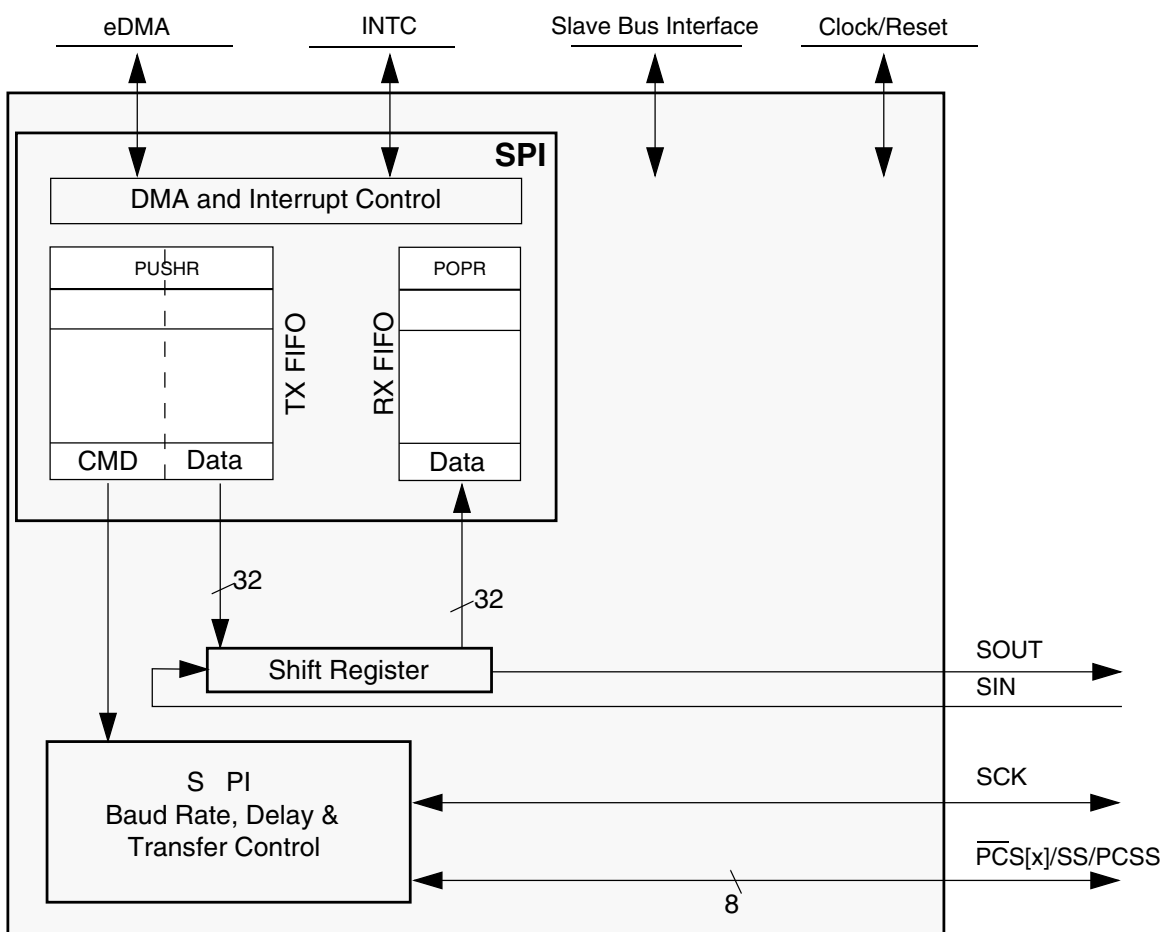

Figure 45-1. DSPI Block Diagram

45.1.2 Features

The DSPI supports these SPI features:

- Full-duplex, Four-wire synchronous transfers
- Master and slave modes
 - Data streaming operation in slave mode with continuous slave selection
- Buffered transmit operation using the TX FIFO with depth of 4 entries
- Buffered receive operation using the RX FIFO with depth of 4 entries
- TX and RX FIFOs can be disabled individually for low-latency updates to SPI queues
- Visibility into TX and RX FIFOs for ease of debugging
- Programmable transfer attributes on a per-frame basis:

- 2 transfer attribute registers
- Serial clock with programmable polarity and phase
- Various programmable delays
- Programmable serial frame size of 4 to 16 bits, expandable by software control
 - SPI frames longer than 16 bits can be supported using the continuous selection format.
- Continuously held chip select capability
- 6 Peripheral Chip Selects, expandable to 64 with external demultiplexer
- Deglitching support for up to 32 Peripheral Chip Select with external demultiplexer
- DMA support for adding entries to TX FIFO and removing entries from RX FIFO:
 - TX FIFO is not full (TFFF)
 - RX FIFO is not empty (RFDF)
- Interrupt conditions:
 - End of queue reached (EOQF)
 - TX FIFO is not full (TFFF)
 - Transfer of current frame complete (TCF)
 - Attempt to transmit with an empty Transmit FIFO (TFUF)
 - RX FIFO is not empty (RFDF)
 - Frame received while Receive FIFO is full (RFOF)
- Global interrupt request line
- Modified SPI transfer formats for communication with slower peripheral devices
- Power-saving architectural features
 - Support for stop mode
 - Support for doze mode

45.1.3 DSPI Configurations

The DSPI module always operates in SPI configuration.

45.1.3.1 SPI Configuration

The SPI configuration allows the DSPI to send and receive serial data. This configuration allows the DSPI to operate as a basic SPI block with internal FIFOs supporting external queues operation. Transmit data and received data reside in separate FIFOs. The host CPU or a DMA controller read the received data from the receive FIFO and write transmit data to the transmit FIFO.

For queued operations the SPI queues can reside in system RAM, external to the DSPI. Data transfers between the queues and the DSPI FIFOs are accomplished by a DMA controller or host CPU. The following figure shows a system example with DMA, DSPI and external queues in system RAM.

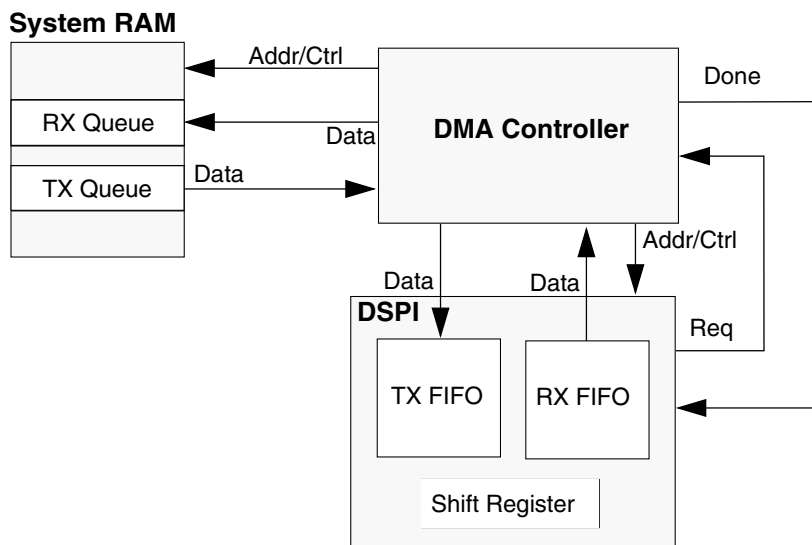

Figure 45-2. DSPI with Queues and DMA

45.1.4 Modes of Operation

The DSPI supports the following modes of operation that can be divided into two categories;

- Module-specific modes:
 - Master mode
 - Slave mode
 - Module disable mode
- MCU-specific modes:

- External stop mode
- Debug mode

The DSPI enters module-specific modes when the host writes a DSPI register. The MCU-specific modes are controlled by signals, external to the DSPI. The MCU-specific modes are modes that an MCU may enter in parallel to the DSPI block-specific modes.

45.1.4.1 Master Mode

Master mode allows the DSPI to initiate and control serial communication. In this mode, the SCK signal and the PCS[x] signals are controlled by the DSPI and configured as outputs.

45.1.4.2 Slave Mode

Slave mode allows the DSPI to communicate with SPI bus masters. In this mode, the DSPI responds to externally controlled serial transfers. The SCK signal and the PCS[0]/ \overline{SS} signals are configured as inputs and driven by a SPI bus master.

45.1.4.3 Module Disable Mode

The module disable mode can be used for MCU power management. The clock to the non-memory mapped logic in the DSPI can be stopped while in the module disable mode.

45.1.4.4 External Stop Mode

External stop mode is used for MCU power management. The DSPI supports the Peripheral Bus stop mode mechanism. When a request is made to enter external stop mode, the DSPI block acknowledges the request and completes the transfer in progress. When the DSPI reaches the frame boundary it signals that the system clock to the DSPI module may be shut off.

45.1.4.5 Debug Mode

Debug mode is used for system development and debugging. The MCR[FRZ] bit controls DSPI behavior in the debug mode. If the bit is set, the DSPI stops all serial transfers, when the MCU is in debug mode. If the bit is cleared, the MCU debug mode has no effect on the DSPI.

45.2 DSPI Signal Descriptions

This section provides the DSPI signals description.

The following table lists the signals that may connect off chip depending on device implementation.

Table 45-1. DSPI Signal Descriptions

Signal	Description	I/O
PCS0/ \overline{SS}	Master mode: Peripheral Chip Select 0 output Slave mode: Slave Select input	I/O
PCS[3:1]	Master mode: Peripheral Chip Select 1 - 3 Slave mode: Unused	O
PCS4	Master mode: Peripheral Chip Select 4 Slave mode: Unused	O
PCS5/ \overline{PCSS}	Master mode: Peripheral Chip Select 5 / Peripheral Chip Select Strobe Slave mode: Unused	O
SIN	Serial Data In	I
SOUT	Serial Data Out	O
SCK	Master mode: Serial Clock (output) Slave mode: Serial Clock (input)	I/O

45.2.1 PCS0/ \overline{SS} — Peripheral Chip Select/Slave Select

In master mode, the PCS0 signal is a Peripheral Chip Select output that selects which slave device the current transmission is intended for.

In slave mode, the active low \overline{SS} signal is a Slave Select input signal that allows a SPI master to select the DSPI as the target for transmission.

45.2.2 PCS1 - PCS3 — Peripheral Chip Selects 1 - 3

PCS1 - PCS3 are Peripheral Chip Select output signals in master mode.

In slave mode, these signals are unused.

45.2.3 PCS4 — Peripheral Chip Select 4

In master mode, PCS4 is a Peripheral Chip Select output signal.

In slave mode, this signal is unused.

45.2.4 PCS5/ $\overline{\text{PCSS}}$ — Peripheral Chip Select 5/Peripheral Chip Select Strobe

PCS5 is a Peripheral Chip Select output signal. When the DSPI is in master mode and the MCR[PCSS] bit is cleared, this signal selects which slave device the current transfer is intended for.

When the DSPI is in master mode and the MCR[PCSS] bit is set, the $\overline{\text{PCSS}}$ signal acts as a strobe to an external peripheral chip select demultiplexer, which decodes the PCS0 - PCS4 signals, preventing glitches on the demultiplexer outputs.

This signal is not used in slave mode.

45.2.5 SIN — Serial Input

SIN is a serial data input signal.

45.2.6 SOUT — Serial Output

SOUT is a serial data output signal.

45.2.7 SCK — Serial Clock

SCK is a serial communication clock signal. In master mode, the DSPI generates the SCK. In slave mode, SCK is an input from an external bus master.

45.3 Memory Map/Register Definition

Register accesses to memory addresses that are reserved or undefined result in a transfer error. Write access to the POPR register also results in a transfer error.

SPI memory map

Absolute address (hex)	Register name	Width (in bits)	Access	Reset value	Section/page
4002_C000	DSPI Module Configuration Register (SPI0_MCR)	32	R/W	0000_4001h	45.3.1/1161
4002_C008	DSPI Transfer Count Register (SPI0_TCR)	32	R/W	0000_0000h	45.3.2/1164
4002_C00C	DSPI Clock and Transfer Attributes Register (In Master Mode) (SPI0_CTAR0)	32	R/W	7800_0000h	45.3.3/1164
4002_C00C	DSPI Clock and Transfer Attributes Register (In Slave Mode) (SPI0_CTAR0_SLAVE)	32	R/W	7800_0000h	45.3.4/1169
4002_C010	DSPI Clock and Transfer Attributes Register (In Master Mode) (SPI0_CTAR1)	32	R/W	7800_0000h	45.3.3/1164
4002_C02C	DSPI Status Register (SPI0_SR)	32	R/W	See section	45.3.5/1170
4002_C030	DSPI DMA/Interrupt Request Select and Enable Register (SPI0_RSER)	32	R/W	0000_0000h	45.3.6/1173
4002_C034	DSPI PUSH TX FIFO Register In Master Mode (SPI0_PUSHR)	32	R/W	0000_0000h	45.3.7/1175
4002_C034	DSPI PUSH TX FIFO Register In Slave Mode (SPI0_PUSHR_SLAVE)	32	R/W	0000_0000h	45.3.8/1177
4002_C038	DSPI POP RX FIFO Register (SPI0_POPR)	32	R	0000_0000h	45.3.9/1177
4002_C03C	DSPI Transmit FIFO Registers (SPI0_TXFR0)	32	R	0000_0000h	45.3.10/1178
4002_C040	DSPI Transmit FIFO Registers (SPI0_TXFR1)	32	R	0000_0000h	45.3.10/1178
4002_C044	DSPI Transmit FIFO Registers (SPI0_TXFR2)	32	R	0000_0000h	45.3.10/1178
4002_C048	DSPI Transmit FIFO Registers (SPI0_TXFR3)	32	R	0000_0000h	45.3.10/1178
4002_C07C	DSPI Receive FIFO Registers (SPI0_RXFR0)	32	R	0000_0000h	45.3.11/1178
4002_C080	DSPI Receive FIFO Registers (SPI0_RXFR1)	32	R	0000_0000h	45.3.11/1178

Table continues on the next page...

SPI memory map (continued)

Absolute address (hex)	Register name	Width (in bits)	Access	Reset value	Section/page
4002_C084	DSPI Receive FIFO Registers (SPI0_RXFR2)	32	R	0000_0000h	45.3.11/1178
4002_C088	DSPI Receive FIFO Registers (SPI0_RXFR3)	32	R	0000_0000h	45.3.11/1178
4002_D000	DSPI Module Configuration Register (SPI1_MCR)	32	R/W	0000_4001h	45.3.1/1161
4002_D008	DSPI Transfer Count Register (SPI1_TCR)	32	R/W	0000_0000h	45.3.2/1164
4002_D00C	DSPI Clock and Transfer Attributes Register (In Master Mode) (SPI1_CTAR0)	32	R/W	7800_0000h	45.3.3/1164
4002_D00C	DSPI Clock and Transfer Attributes Register (In Slave Mode) (SPI1_CTAR0_SLAVE)	32	R/W	7800_0000h	45.3.4/1169
4002_D010	DSPI Clock and Transfer Attributes Register (In Master Mode) (SPI1_CTAR1)	32	R/W	7800_0000h	45.3.3/1164
4002_D02C	DSPI Status Register (SPI1_SR)	32	R/W	See section	45.3.5/1170
4002_D030	DSPI DMA/Interrupt Request Select and Enable Register (SPI1_RSER)	32	R/W	0000_0000h	45.3.6/1173
4002_D034	DSPI PUSH TX FIFO Register In Master Mode (SPI1_PUSHR)	32	R/W	0000_0000h	45.3.7/1175
4002_D034	DSPI PUSH TX FIFO Register In Slave Mode (SPI1_PUSHR_SLAVE)	32	R/W	0000_0000h	45.3.8/1177
4002_D038	DSPI POP RX FIFO Register (SPI1_POPR)	32	R	0000_0000h	45.3.9/1177
4002_D03C	DSPI Transmit FIFO Registers (SPI1_TXFR0)	32	R	0000_0000h	45.3.10/1178
4002_D040	DSPI Transmit FIFO Registers (SPI1_TXFR1)	32	R	0000_0000h	45.3.10/1178
4002_D044	DSPI Transmit FIFO Registers (SPI1_TXFR2)	32	R	0000_0000h	45.3.10/1178
4002_D048	DSPI Transmit FIFO Registers (SPI1_TXFR3)	32	R	0000_0000h	45.3.10/1178
4002_D07C	DSPI Receive FIFO Registers (SPI1_RXFR0)	32	R	0000_0000h	45.3.11/1178
4002_D080	DSPI Receive FIFO Registers (SPI1_RXFR1)	32	R	0000_0000h	45.3.11/1178
4002_D084	DSPI Receive FIFO Registers (SPI1_RXFR2)	32	R	0000_0000h	45.3.11/1178
4002_D088	DSPI Receive FIFO Registers (SPI1_RXFR3)	32	R	0000_0000h	45.3.11/1178

SPI memory map (continued)

Absolute address (hex)	Register name	Width (in bits)	Access	Reset value	Section/page
400A_C000	DSPI Module Configuration Register (SPI2_MCR)	32	R/W	0000_4001h	45.3.1/1161
400A_C008	DSPI Transfer Count Register (SPI2_TCR)	32	R/W	0000_0000h	45.3.2/1164
400A_C00C	DSPI Clock and Transfer Attributes Register (In Master Mode) (SPI2_CTAR0)	32	R/W	7800_0000h	45.3.3/1164
400A_C00C	DSPI Clock and Transfer Attributes Register (In Slave Mode) (SPI2_CTAR0_SLAVE)	32	R/W	7800_0000h	45.3.4/1169
400A_C010	DSPI Clock and Transfer Attributes Register (In Master Mode) (SPI2_CTAR1)	32	R/W	7800_0000h	45.3.3/1164
400A_C02C	DSPI Status Register (SPI2_SR)	32	R/W	See section	45.3.5/1170
400A_C030	DSPI DMA/Interrupt Request Select and Enable Register (SPI2_RSER)	32	R/W	0000_0000h	45.3.6/1173
400A_C034	DSPI PUSH TX FIFO Register In Master Mode (SPI2_PUSHR)	32	R/W	0000_0000h	45.3.7/1175
400A_C034	DSPI PUSH TX FIFO Register In Slave Mode (SPI2_PUSHR_SLAVE)	32	R/W	0000_0000h	45.3.8/1177
400A_C038	DSPI POP RX FIFO Register (SPI2_POPR)	32	R	0000_0000h	45.3.9/1177
400A_C03C	DSPI Transmit FIFO Registers (SPI2_TXFR0)	32	R	0000_0000h	45.3.10/1178
400A_C040	DSPI Transmit FIFO Registers (SPI2_TXFR1)	32	R	0000_0000h	45.3.10/1178
400A_C044	DSPI Transmit FIFO Registers (SPI2_TXFR2)	32	R	0000_0000h	45.3.10/1178
400A_C048	DSPI Transmit FIFO Registers (SPI2_TXFR3)	32	R	0000_0000h	45.3.10/1178
400A_C07C	DSPI Receive FIFO Registers (SPI2_RXFR0)	32	R	0000_0000h	45.3.11/1178
400A_C080	DSPI Receive FIFO Registers (SPI2_RXFR1)	32	R	0000_0000h	45.3.11/1178
400A_C084	DSPI Receive FIFO Registers (SPI2_RXFR2)	32	R	0000_0000h	45.3.11/1178
400A_C088	DSPI Receive FIFO Registers (SPI2_RXFR3)	32	R	0000_0000h	45.3.11/1178

45.3.1 DSPI Module Configuration Register (SPIx_MCR)

Contains bits to configure various attributes associated with DSPI operations. The HALT and MDIS bits can be changed at any time, but they only take effect on the next frame boundary. Only the HALT and MDIS bits in the MCR can be changed, while the DSPI is in the Running state.

Addresses: SPI0_MCR is 4002_C000h base + 0h offset = 4002_C000h

SPI1_MCR is 4002_D000h base + 0h offset = 4002_D000h

SPI2_MCR is 400A_C000h base + 0h offset = 400A_C000h

Bit	31	30	29	28	27	26	25	24	23	22	21	20	19	18	17	16
R									0							
W	MSTR	CONT_SCKE	DCONF		FRZ	MTFE	PCSSE	ROOE			PCISIS[5:0]					
Reset	0	0	0	0	0	0	0	0	0	0	0	0	0	0	0	0
Bit	15	14	13	12	11	10	9	8	7	6	5	4	3	2	1	0
R					0	0	SMPL_PT		0						0	
W	DOZE	MDIS	DIS_TXF	DIS_RXF	CLR_TXF	CLR_RXF									HALT	
Reset	0	1	0	0	0	0	0	0	0	0	0	0	0	0	0	1

SPIx_MCR field descriptions

Field	Description
31 MSTR	Master/Slave Mode Select Configures the DSPI for either master mode or slave mode. 0 DSPI is in slave mode. 1 DSPI is in master mode.
30 CONT_SCKE	Continuous SCK Enable Enables the Serial Communication Clock (SCK) to run continuously. 0 Continuous SCK disabled. 1 Continuous SCK enabled.
29–28 DCONF	DSPI Configuration Selects among the different configurations of the DSPI. 00 SPI 01 Reserved 10 Reserved 11 Reserved

Table continues on the next page...

SPIx_MCR field descriptions (continued)

Field	Description
27 FRZ	<p>Freeze</p> <p>Enables the DSPI transfers to be stopped on the next frame boundary when the device enters Debug mode.</p> <p>0 Do not halt serial transfers in debug mode. 1 Halt serial transfers in debug mode.</p>
26 MTFE	<p>Modified Timing Format Enable</p> <p>Enables a modified transfer format to be used.</p> <p>0 Modified SPI transfer format disabled. 1 Modified SPI transfer format enabled.</p>
25 PCSSE	<p>Peripheral Chip Select Strobe Enable</p> <p>Enables the PCS[5]/ $\overline{\text{PCSS}}$ to operate as a PCS Strobe output signal.</p> <p>0 PCS[5]/$\overline{\text{PCSS}}$ is used as the Peripheral Chip Select[5] signal. 1 PCS[5]/PCSS is used as an active-low PCS Strobe signal.</p>
24 ROOE	<p>Receive FIFO Overflow Overwrite Enable</p> <p>In the RX FIFO overflow condition, configures the DSPI to ignore the incoming serial data or overwrite existing data. If the RX FIFO is full and new data is received, the data from the transfer, generating the overflow, is ignored or shifted into the shift register.</p> <p>0 Incoming data is ignored. 1 Incoming data is shifted into the shift register.</p>
23–22 Reserved	<p>This read-only field is reserved and always has the value zero.</p>
21–16 PCSI5[5:0]	<p>Peripheral Chip Select x Inactive State</p> <p>Determines the inactive state of PCSx.</p> <p>0 The inactive state of PCSx is low. 1 The inactive state of PCSx is high.</p>
15 DOZE	<p>Doze Enable</p> <p>Provides support for an externally controlled Doze mode power-saving mechanism.</p> <p>0 Doze mode has no effect on DSPI. 1 Doze mode disables DSPI.</p>
14 MDIS	<p>Module Disable</p> <p>Allows the clock to be stopped to the non-memory mapped logic in the DSPI effectively putting the DSPI in a software controlled power-saving state. The reset value of the MDIS bit is parameterized, with a default reset value of "0".</p> <p>0 Enable DSPI clocks. 1 Allow external logic to disable DSPI clocks.</p>

Table continues on the next page...

SPIx_MCR field descriptions (continued)

Field	Description
13 DIS_TXF	Disable Transmit FIFO When the TX FIFO is disabled, the transmit part of the DSPI operates as a simplified double-buffered SPI. This bit can only be written when the MDIS bit is cleared. 0 Tx FIFO is enabled. 1 Tx FIFO is disabled.
12 DIS_RXF	Disable Receive FIFO When the RX FIFO is disabled, the receive part of the DSPI operates as a simplified double-buffered SPI. This bit can only be written when the MDIS bit is cleared. 0 Rx FIFO is enabled. 1 Rx FIFO is disabled.
11 CLR_TXF	Clear TX FIFO Flushes the TX FIFO. Writing a 1 to CLR_TXF clears the TX FIFO Counter. The CLR_TXF bit is always read as zero. 0 Do not clear the Tx FIFO counter. 1 Clear the Tx FIFO counter.
10 CLR_RXF	Flushes the RX FIFO. Writing a 1 to CLR_RXF clears the RX Counter. The CLR_RXF bit is always read as zero. 0 Do not clear the Rx FIFO counter. 1 Clear the Rx FIFO counter.
9–8 SMPL_PT	Sample Point Controls when the DSPI master samples SIN in Modified Transfer Format. This field is valid only when CPHA bit in CTAR register is 0. 00 0 system clocks between SCK edge and SIN sample 01 1 system clock between SCK edge and SIN sample 10 2 system clocks between SCK edge and SIN sample 11 Reserved
7–2 Reserved	This read-only field is reserved and always has the value zero.
1 Reserved	This read-only field is reserved and always has the value zero.
0 HALT	Halt Starts and stops DSPI transfers. 0 Start transfers. 1 Stop transfers.

45.3.2 DSPI Transfer Count Register (SPIx_TCR)

TCR contains a counter that indicates the number of SPI transfers made. The transfer counter is intended to assist in queue management. Do not write the TCR when the DSPI is in the Running state.

Addresses: SPI0_TCR is 4002_C000h base + 8h offset = 4002_C008h
 SPI1_TCR is 4002_D000h base + 8h offset = 4002_D008h
 SPI2_TCR is 400A_C000h base + 8h offset = 400A_C008h

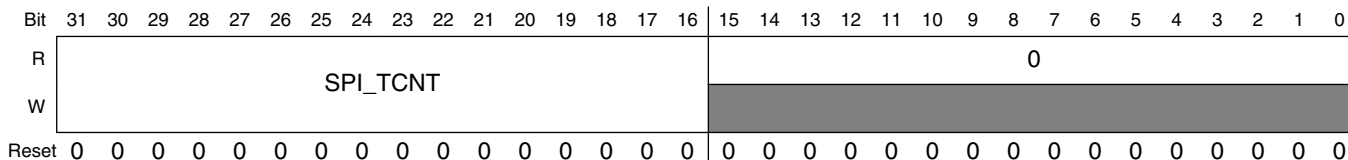

SPIx_TCR field descriptions

Field	Description
31–16 SPI_TCNT	SPI Transfer Counter Counts the number of SPI transfers the DSPI makes. The SPI_TCNT field increments every time the last bit of a SPI frame is transmitted. A value written to SPI_TCNT presets the counter to that value. SPI_TCNT is reset to zero at the beginning of the frame when the CTCNT field is set in the executing SPI command. The Transfer Counter wraps around; incrementing the counter past 65535 resets the counter to zero.
15–0 Reserved	This read-only field is reserved and always has the value zero.

45.3.3 DSPI Clock and Transfer Attributes Register (In Master Mode) (SPIx_CTARn)

CTAR registers are used to define different transfer attributes. The number of CTAR registers is parameterized in the RTL and can be from two to eight registers. Do not write to the CTAR registers while the DSPI is in the Running state.

In master mode, the CTAR registers define combinations of transfer attributes such as frame size, clock phase and polarity, data bit ordering, baud rate, and various delays. In slave mode, a subset of the bitfields in CTAR0 are used to set the slave transfer attributes.

When the DSPI is configured as an SPI master, the CTAS field in the command portion of the TX FIFO entry selects which of the CTAR register is used. When the DSPI is configured as an SPI bus slave, the CTAR0 register is used.

Addresses: SPI0_CTAR0 is 4002_C000h base + Ch offset = 4002_C00Ch
 SPI0_CTAR1 is 4002_C000h base + 10h offset = 4002_C010h
 SPI1_CTAR0 is 4002_D000h base + Ch offset = 4002_D00Ch
 SPI1_CTAR1 is 4002_D000h base + 10h offset = 4002_D010h
 SPI2_CTAR0 is 400A_C000h base + Ch offset = 400A_C00Ch
 SPI2_CTAR1 is 400A_C000h base + 10h offset = 400A_C010h

Bit	31	30	29	28	27	26	25	24	23	22	21	20	19	18	17	16
R	DBR		FMSZ				CPOL	CPHA	LSBFE	PCSSCK		PASC	PDT		PBR	
W																
Reset	0	1	1	1	1	0	0	0	0	0	0	0	0	0	0	0

Bit	15	14	13	12	11	10	9	8	7	6	5	4	3	2	1	0
R	CSSCK				ASC				DT				BR			
W																
Reset	0	0	0	0	0	0	0	0	0	0	0	0	0	0	0	0

SPIx_CTARn field descriptions

Field	Description																																								
31 DBR	<p>Double Baud Rate</p> <p>Doubles the effective baud rate of the Serial Communications Clock (SCK). This field is used only in master mode. It effectively halves the Baud Rate division ratio, supporting faster frequencies, and odd division ratios for the Serial Communications Clock (SCK). When the DBR bit is set, the duty cycle of the Serial Communications Clock (SCK) depends on the value in the Baud Rate Prescaler and the Clock Phase bit as listed in the following table. See the BR field description for details on how to compute the baud rate.</p> <p style="text-align: center;">Table 45-32. DSPI SCK Duty Cycle</p> <table border="1" style="margin-left: auto; margin-right: auto;"> <thead> <tr> <th>DBR</th> <th>CPHA</th> <th>PBR</th> <th>SCK Duty Cycle</th> </tr> </thead> <tbody> <tr> <td>0</td> <td>any</td> <td>any</td> <td>50/50</td> </tr> <tr> <td>1</td> <td>0</td> <td>00</td> <td>50/50</td> </tr> <tr> <td>1</td> <td>0</td> <td>01</td> <td>33/66</td> </tr> <tr> <td>1</td> <td>0</td> <td>10</td> <td>40/60</td> </tr> <tr> <td>1</td> <td>0</td> <td>11</td> <td>43/57</td> </tr> <tr> <td>1</td> <td>1</td> <td>00</td> <td>50/50</td> </tr> <tr> <td>1</td> <td>1</td> <td>01</td> <td>66/33</td> </tr> <tr> <td>1</td> <td>1</td> <td>10</td> <td>60/40</td> </tr> <tr> <td>1</td> <td>1</td> <td>11</td> <td>57/43</td> </tr> </tbody> </table> <p>0 The baud rate is computed normally with a 50/50 duty cycle. 1 The baud rate is doubled with the duty cycle depending on the Baud Rate Prescaler.</p>	DBR	CPHA	PBR	SCK Duty Cycle	0	any	any	50/50	1	0	00	50/50	1	0	01	33/66	1	0	10	40/60	1	0	11	43/57	1	1	00	50/50	1	1	01	66/33	1	1	10	60/40	1	1	11	57/43
DBR	CPHA	PBR	SCK Duty Cycle																																						
0	any	any	50/50																																						
1	0	00	50/50																																						
1	0	01	33/66																																						
1	0	10	40/60																																						
1	0	11	43/57																																						
1	1	00	50/50																																						
1	1	01	66/33																																						
1	1	10	60/40																																						
1	1	11	57/43																																						

Table continues on the next page...

SPIx_CTARn field descriptions (continued)

Field	Description
30–27 FMSZ	<p>Frame Size</p> <p>The number of bits transferred per frame is equal to the FMSZ field value plus 1. The minimum valid FMSZ field value is 3.</p>
26 CPOL	<p>Clock Polarity</p> <p>Selects the inactive state of the Serial Communications Clock (SCK). This bit is used in both master and slave mode. For successful communication between serial devices, the devices must have identical clock polarities. When the Continuous Selection Format is selected, switching between clock polarities without stopping the DSPIC can cause errors in the transfer due to the peripheral device interpreting the switch of clock polarity as a valid clock edge.</p> <p>0 The inactive state value of SCK is low. 1 The inactive state value of SCK is high.</p>
25 CPHA	<p>Clock Phase</p> <p>Selects which edge of SCK causes data to change and which edge causes data to be captured. This bit is used in both master and slave mode. For successful communication between serial devices, the devices must have identical clock phase settings. In Continuous SCK mode, the bit value is ignored and the transfers are done as if the CPHA bit is set to 1.</p> <p>0 Data is captured on the leading edge of SCK and changed on the following edge. 1 Data is changed on the leading edge of SCK and captured on the following edge.</p>
24 LSBFE	<p>LBS First</p> <p>Specifies whether the LSB or MSB of the frame is transferred first.</p> <p>0 Data is transferred MSB first. 1 Data is transferred LSB first.</p>
23–22 PCSSCK	<p>PCS to SCK Delay Prescaler</p> <p>Selects the prescaler value for the delay between assertion of PCS and the first edge of the SCK. See the CSSCK field description for information on how to compute the PCS to SCK Delay. Refer PCS to SCK Delay (t_{CSC}) for more details.</p> <p>00 PCS to SCK Prescaler value is 1. 01 PCS to SCK Prescaler value is 3. 10 PCS to SCK Prescaler value is 5. 11 PCS to SCK Prescaler value is 7.</p>
21–20 PASC	<p>After SCK Delay Prescaler</p> <p>Selects the prescaler value for the delay between the last edge of SCK and the negation of PCS. See the ASC field description for information on how to compute the After SCK Delay. Refer After SCK Delay (t_{ASC}) for more details.</p> <p>00 Delay after Transfer Prescaler value is 1. 01 Delay after Transfer Prescaler value is 3. 10 Delay after Transfer Prescaler value is 5. 11 Delay after Transfer Prescaler value is 7.</p>
19–18 PDT	<p>Delay after Transfer Prescaler</p>

Table continues on the next page...

SPIx_CTARn field descriptions (continued)

Field	Description																														
	<p>Selects the prescaler value for the delay between the negation of the PCS signal at the end of a frame and the assertion of PCS at the beginning of the next frame. The PDT field is only used in master mode. See the DT field description for details on how to compute the Delay after Transfer. Refer Delay after Transfer (t_{DT}) for more details.</p> <p>00 Delay after Transfer Prescaler value is 1. 01 Delay after Transfer Prescaler value is 3. 10 Delay after Transfer Prescaler value is 5. 11 Delay after Transfer Prescaler value is 7.</p>																														
17–16 PBR	<p>Baud Rate Prescaler</p> <p>Selects the prescaler value for the baud rate. This field is used only in master mode. The baud rate is the frequency of the SCK. The system clock is divided by the prescaler value before the baud rate selection takes place. See the BR field description for details on how to compute the baud rate.</p> <p>00 Baud Rate Prescaler value is 2. 01 Baud Rate Prescaler value is 3. 10 Baud Rate Prescaler value is 5. 11 Baud Rate Prescaler value is 7.</p>																														
15–12 CSSCK	<p>PCS to SCK Delay Scaler</p> <p>Selects the scaler value for the PCS to SCK delay. This field is used only in master mode. The PCS to SCK Delay is the delay between the assertion of PCS and the first edge of the SCK. The delay is a multiple of the system clock period, and it is computed according to the following equation:</p> $t_{CSC} = (1/f_{SYS}) \times PCSSCK \times CSSCK$ <p>The following table lists the delay scaler values.</p> <p style="text-align: center;">Table 45-33. Delay Scaler Encoding</p> <table border="1" style="margin-left: auto; margin-right: auto;"> <thead> <tr> <th>Field Value</th> <th>Delay Scaler Value</th> </tr> </thead> <tbody> <tr><td>0000</td><td>2</td></tr> <tr><td>0001</td><td>4</td></tr> <tr><td>0010</td><td>8</td></tr> <tr><td>0011</td><td>16</td></tr> <tr><td>0100</td><td>32</td></tr> <tr><td>0101</td><td>64</td></tr> <tr><td>0110</td><td>128</td></tr> <tr><td>0111</td><td>256</td></tr> <tr><td>1000</td><td>512</td></tr> <tr><td>1001</td><td>1024</td></tr> <tr><td>1010</td><td>2048</td></tr> <tr><td>1011</td><td>4096</td></tr> <tr><td>1100</td><td>8192</td></tr> <tr><td>1101</td><td>16384</td></tr> </tbody> </table>	Field Value	Delay Scaler Value	0000	2	0001	4	0010	8	0011	16	0100	32	0101	64	0110	128	0111	256	1000	512	1001	1024	1010	2048	1011	4096	1100	8192	1101	16384
Field Value	Delay Scaler Value																														
0000	2																														
0001	4																														
0010	8																														
0011	16																														
0100	32																														
0101	64																														
0110	128																														
0111	256																														
1000	512																														
1001	1024																														
1010	2048																														
1011	4096																														
1100	8192																														
1101	16384																														

Table continues on the next page...

SPIx_CTARn field descriptions (continued)

Field	Description																		
	<p align="center">Table 45-33. Delay Scaler Encoding (continued)</p> <table border="1"> <thead> <tr> <th>Field Value</th> <th>Delay Scaler Value</th> </tr> </thead> <tbody> <tr> <td align="center">1110</td> <td align="center">32768</td> </tr> <tr> <td align="center">1111</td> <td align="center">65536</td> </tr> </tbody> </table> <p>Refer PCS to SCK Delay (t_{CSC}) for more details.</p>	Field Value	Delay Scaler Value	1110	32768	1111	65536												
Field Value	Delay Scaler Value																		
1110	32768																		
1111	65536																		
11–8 ASC	<p>After SCK Delay Scaler</p> <p>Selects the scaler value for the After SCK Delay. This field is used only in master mode. The After SCK Delay is the delay between the last edge of SCK and the negation of PCS. The delay is a multiple of the system clock period, and it is computed according to the following equation:</p> $t_{ASC} = (1/f_{SYS}) \times PASC \times ASC$ <p>See Delay Scaler Encoding table in CTARn[CSSCK] bit field description for scaler values. Refer After SCK Delay (t_{ASC}) for more details.</p>																		
7–4 DT	<p>Delay After Transfer Scaler</p> <p>Selects the Delay after Transfer Scaler. This field is used only in master mode. The Delay after Transfer is the time between the negation of the PCS signal at the end of a frame and the assertion of PCS at the beginning of the next frame.</p> <p>In the Continuous Serial Communications Clock operation, the DT value is fixed to one SCK clock period, The Delay after Transfer is a multiple of the system clock period, and it is computed according to the following equation:</p> $t_{DT} = (1/f_{SYS}) \times PDT \times DT$ <p>See Delay Scaler Encoding table in CTARn[CSSCK] bit field description for scaler values.</p>																		
3–0 BR	<p>Baud Rate Scaler</p> <p>Selects the scaler value for the baud rate. This field is used only in master mode. The prescaled system clock is divided by the Baud Rate Scaler to generate the frequency of the SCK. The baud rate is computed according to the following equation:</p> $SCK \text{ baud rate} = (f_{SYS}/PBR) \times [(1+DBR)/BR]$ <p>The following table lists the baud rate scaler values.</p> <p align="center">Table 45-34. DSPI Baud Rate Scaler</p> <table border="1"> <thead> <tr> <th>CTARn[BR]</th> <th>Baud Rate Scaler Value</th> </tr> </thead> <tbody> <tr> <td align="center">0000</td> <td align="center">2</td> </tr> <tr> <td align="center">0001</td> <td align="center">4</td> </tr> <tr> <td align="center">0010</td> <td align="center">6</td> </tr> <tr> <td align="center">0011</td> <td align="center">8</td> </tr> <tr> <td align="center">0100</td> <td align="center">16</td> </tr> <tr> <td align="center">0101</td> <td align="center">32</td> </tr> <tr> <td align="center">0110</td> <td align="center">64</td> </tr> <tr> <td align="center">0111</td> <td align="center">128</td> </tr> </tbody> </table>	CTARn[BR]	Baud Rate Scaler Value	0000	2	0001	4	0010	6	0011	8	0100	16	0101	32	0110	64	0111	128
CTARn[BR]	Baud Rate Scaler Value																		
0000	2																		
0001	4																		
0010	6																		
0011	8																		
0100	16																		
0101	32																		
0110	64																		
0111	128																		

Table continues on the next page...

SPIx_CTARn field descriptions (continued)

Field	Description	
	Table 45-34. DSPI Baud Rate Scaler (continued)	
	CTARn[BR]	Baud Rate Scaler Value
	1000	256
	1001	512
	1010	1024
	1011	2048
	1100	4096
	1101	8192
	1110	16384
	1111	32768

45.3.4 DSPI Clock and Transfer Attributes Register (In Slave Mode) (SPIx_CTAR_SLAVE)

When the DSPI is configured as an SPI bus slave, the CTAR0 register is used.

Addresses: SPI0_CTAR0_SLAVE is 4002_C000h base + Ch offset = 4002_C00Ch

SPI1_CTAR0_SLAVE is 4002_D000h base + Ch offset = 4002_D00Ch

SPI2_CTAR0_SLAVE is 400A_C000h base + Ch offset = 400A_C00Ch

Bit	31	30	29	28	27	26	25	24	23	22	21	20	19	18	17	16	15	14	13	12	11	10	9	8	7	6	5	4	3	2	1	0
R						0		0																								
W	FMSZ					CPOL	CPHA																									
Reset	0	1	1	1	1	0	0	0	0	0	0	0	0	0	0	0	0	0	0	0	0	0	0	0	0	0	0	0	0	0	0	0

SPIx_CTARn_SLAVE field descriptions

Field	Description
31–27 FMSZ	Frame Size The number of bits transferred per frame is equal to the FMSZ field value plus 1. The minimum valid FMSZ field value is 3.
26 CPOL	Clock Polarity Selects the inactive state of the Serial Communications Clock (SCK). 0 The inactive state value of SCK is low. 1 The inactive state value of SCK is high.
25 CPHA	Clock Phase

Table continues on the next page...

SPIx_CTARn_SLAVE field descriptions (continued)

Field	Description
	<p>Selects which edge of SCK causes data to change and which edge causes data to be captured. This bit is used in both master and slave mode. For successful communication between serial devices, the devices must have identical clock phase settings. In Continuous SCK mode, the bit value is ignored and the transfers are done as the CPHA bit is set to 1.</p> <p>0 Data is captured on the leading edge of SCK and changed on the following edge. 1 Data is changed on the leading edge of SCK and captured on the following edge.</p>
24–23 Reserved	This read-only field is reserved and always has the value zero.
22–0 Reserved	This read-only field is reserved and always has the value zero.

45.3.5 DSPI Status Register (SPIx_SR)

SR contains status and flag bits. The bits reflect the status of the DSPI and indicate the occurrence of events that can generate interrupt or DMA requests. Software can clear flag bits in the SR by writing a 1 to them. Writing a 0 to a flag bit has no effect. This register may not be writable in module disable mode due to the use of power saving mechanisms.

Addresses: SPI0_SR is 4002_C000h base + 2Ch offset = 4002_C02Ch

SPI1_SR is 4002_D000h base + 2Ch offset = 4002_D02Ch

SPI2_SR is 400A_C000h base + 2Ch offset = 400A_C02Ch

Bit	31	30	29	28	27	26	25	24	23	22	21	20	19	18	17	16
R	TCF	TXRXS	0	EOQF	TFUF	0	TFFF	0	0	0	0	0	RFOF	0	RFDF	0
W	w1c	w1c		w1c	w1c		w1c						w1c		w1c	
Reset	0	0	0	0	0	0	*	0	0	0	0	0	0	0	0	0
Bit	15	14	13	12	11	10	9	8	7	6	5	4	3	2	1	0
R	TXCTR				TXNXTPTR				RXCTR				POPNTPTR			
W																
Reset	0	0	0	0	0	0	0	0	0	0	0	0	0	0	0	0

* Notes:

- TFFF bitfield: Depends on MCR[MDIS] bit. See bit description for more details.

SPIx_SR field descriptions

Field	Description
31 TCF	<p>Transfer Complete Flag</p> <p>Indicates that all bits in a frame have been shifted out. TCF remains set until it is cleared by writing a 1 to it.</p> <p>0 Transfer not complete. 1 Transfer complete.</p>
30 TXRXS	<p>TX and RX Status</p> <p>Reflects the run status of the DSPI.</p> <p>0 Transmit and receive operations are disabled (DSPI is in stopped state). 1 Transmit and receive operations are enabled (DSPI is in running state).</p>
29 Reserved	This read-only field is reserved and always has the value zero.
28 EOQF	<p>End of Queue Flag</p> <p>Indicates that the last entry in a queue has been transmitted when the DSPI is in master mode. The EOQF bit is set when the TX FIFO entry has the EOQ bit set in the command halfword and the end of the transfer is reached. The EOQF bit remains set until cleared by writing a 1 to it. When the EOQF bit is set, the TXRXS bit is automatically cleared.</p> <p>0 EOQ is not set in the executing command. 1 EOQ is set in the executing SPI command.</p>
27 TFUF	<p>Transmit FIFO Underflow Flag</p> <p>Indicates an underflow condition in the TX FIFO. The transmit underflow condition is detected only for DSPI blocks operating in slave mode and SPI configuration. TFUF is set when the TX FIFO of a DSPI operating in SPI slave mode is empty and an external SPI master initiates a transfer. The TFUF bit remains set until cleared by writing 1 to it.</p> <p>0 No Tx FIFO underflow. 1 Tx FIFO underflow has occurred.</p>
26 Reserved	This read-only field is reserved and always has the value zero.
25 TFFF	<p>Transmit FIFO Fill Flag</p> <p>Provides a method for the DSPI to request more entries to be added to the TX FIFO. The TFFF bit is set while the TX FIFO is not full. The TFFF bit can be cleared by writing 1 to it or by acknowledgement from the DMA controller to the TX FIFO full request. The Reset Value of this bit is 0 if MCR[MDIS] = 1. The Reset Value of this bit is 1 if MCR[MDIS] = 0.</p> <p>0 Tx FIFO is full. 1 Tx FIFO is not full.</p>
24 Reserved	This read-only field is reserved and always has the value zero.
23 Reserved	This read-only field is reserved and always has the value zero.
22 Reserved	This read-only field is reserved and always has the value zero.

Table continues on the next page...

SPIx_SR field descriptions (continued)

Field	Description
21 Reserved	This read-only field is reserved and always has the value zero.
20 Reserved	This read-only field is reserved and always has the value zero.
19 RFOF	<p>Receive FIFO Overflow Flag</p> <p>Indicates an overflow condition in the RX FIFO. The bit is set when the RX FIFO and shift register are full and a transfer is initiated. The bit remains set until it is cleared by writing a 1 to it.</p> <p>0 No Rx FIFO overflow. 1 Rx FIFO overflow has occurred.</p>
18 Reserved	This read-only field is reserved and always has the value zero.
17 RFDF	<p>Receive FIFO Drain Flag</p> <p>Provides a method for the DSPI to request that entries be removed from the RX FIFO. The bit is set while the RX FIFO is not empty. The RFDF bit can be cleared by writing 1 to it or by acknowledgement from the DMA controller when the RX FIFO is empty.</p> <p>0 Rx FIFO is empty. 1 Rx FIFO is not empty.</p>
16 Reserved	This read-only field is reserved and always has the value zero.
15–12 TXCTR	<p>TX FIFO Counter</p> <p>Indicates the number of valid entries in the TX FIFO. The TXCTR is incremented every time the PUSHR is written. The TXCTR is decremented every time a SPI command is executed and the SPI data is transferred to the shift register.</p>
11–8 TXNXPTR	<p>Transmit Next Pointer</p> <p>Indicates which TX FIFO Entry is transmitted during the next transfer. The TXNXPTR field is updated every time SPI data is transferred from the TX FIFO to the shift register.</p>
7–4 RXCTR	<p>RX FIFO Counter</p> <p>Indicates the number of entries in the RX FIFO. The RXCTR is decremented every time the POPR is read. The RXCTR is incremented every time data is transferred from the shift register to the RX FIFO.</p>
3–0 POPXPTR	<p>Pop Next Pointer</p> <p>Contains a pointer to the RX FIFO entry to be returned when the POPR is read. The POPXPTR is updated when the POPR is read.</p>

45.3.6 DSPI DMA/Interrupt Request Select and Enable Register (SPIx_RSER)

RSER controls DMA and interrupt requests. Do not write to the RSER while the DSPI is in the Running state.

Addresses: SPI0_RSER is 4002_C000h base + 30h offset = 4002_C030h

SPI1_RSER is 4002_D000h base + 30h offset = 4002_D030h

SPI2_RSER is 400A_C000h base + 30h offset = 400A_C030h

Bit	31	30	29	28	27	26	25	24	23	22	21	20	19	18	17	16
R		0	0	EOQF_RE	TFUF_RE	0	TFUF_RE	TFUF_DIRS	0	0	0	0	RFOF_RE	0	RFDF_RE	RFDF_DIRS
W	TCF_RE															
Reset	0	0	0	0	0	0	0	0	0	0	0	0	0	0	0	0
Bit	15	14	13	12	11	10	9	8	7	6	5	4	3	2	1	0
R	0															
W																
Reset	0	0	0	0	0	0	0	0	0	0	0	0	0	0	0	0

SPIx_RSER field descriptions

Field	Description
31 TCF_RE	Transmission Complete Request Enable Enables TCF flag in the SR to generate an interrupt request. 0 TCF interrupt requests are disabled. 1 TCF interrupt requests are enabled.
30 Reserved	This read-only field is reserved and always has the value zero.
29 Reserved	This read-only field is reserved and always has the value zero.
28 EOQF_RE	DSPI Finished Request Enable Enables the EOQF flag in the SR to generate an interrupt request. 0 EOQF interrupt requests are disabled. 1 EOQF interrupt requests are enabled.
27 TFUF_RE	Transmit FIFO Underflow Request Enable Enables the TFUF flag in the SR to generate an interrupt request. 0 TFUF interrupt requests are disabled. 1 TFUF interrupt requests are enabled.

Table continues on the next page...

SPIx_RSER field descriptions (continued)

Field	Description
26 Reserved	This read-only field is reserved and always has the value zero.
25 TFFF_RE	<p>Transmit FIFO Fill Request Enable</p> <p>Enables the TFFF flag in the SR to generate a request. The TFFF_DIRS bit selects between generating an interrupt request or a DMA request.</p> <p>0 TFFF interrupts or DMA requests are disabled. 1 TFFF interrupts or DMA requests are enabled.</p>
24 TFFF_DIRS	<p>Transmit FIFO Fill DMA or Interrupt Request Select</p> <p>Selects between generating a DMA request or an interrupt request. When the TFFF flag bit in the SR is set and the TFFF_RE bit in the RSER register is set, this bit selects between generating an interrupt request or a DMA request.</p> <p>0 TFFF flag generates interrupt requests. 1 TFFF flag generates DMA requests.</p>
23 Reserved	This read-only field is reserved and always has the value zero.
22 Reserved	This read-only field is reserved and always has the value zero.
21 Reserved	This read-only field is reserved and always has the value zero.
20 Reserved	This read-only field is reserved and always has the value zero.
19 RFOF_RE	<p>Receive FIFO Overflow Request Enable</p> <p>Enables the RFOF flag in the SR to generate an interrupt request.</p> <p>0 RFOF interrupt requests are disabled. 1 RFOF interrupt requests are enabled.</p>
18 Reserved	This read-only field is reserved and always has the value zero.
17 RFDF_RE	<p>Receive FIFO Drain Request Enable</p> <p>Enables the RFDF flag in the SR to generate a request. The RFDF_DIRS bit selects between generating an interrupt request or a DMA request.</p> <p>0 RFDF interrupt or DMA requests are disabled 1 RFDF interrupt or DMA requests are enabled</p>
16 RFDF_DIRS	<p>Receive FIFO Drain DMA or Interrupt Request Select.</p> <p>Selects between generating a DMA request or an interrupt request. When the RFDF flag bit in the SR is set, and the RFDF_RE bit in the RSER is set, the RFDF_DIRS bit selects between generating an interrupt request or a DMA request.</p> <p>0 Interrupt request. 1 DMA request.</p>

Table continues on the next page...

SPIx_RSER field descriptions (continued)

Field	Description
15–0 Reserved	This read-only field is reserved and always has the value zero.

45.3.7 DSPI PUSH TX FIFO Register In Master Mode (SPIx_PUSHR)

PUSHR provides the means to write to the TX FIFO. Data written to this register is transferred to the TX FIFO. Eight- or sixteen-bit write accesses to the PUSHR transfer all 32 register bits to the TX FIFO. The register structure is different in master and slave modes. In master mode the register provides 16-bit command and 16-bit data to the TX FIFO. In slave mode all 32 register bits can be used as data, supporting up to 32-bit SPI frame operation.

Addresses: SPI0_PUSHR is 4002_C000h base + 34h offset = 4002_C034h

SPI1_PUSHR is 4002_D000h base + 34h offset = 4002_D034h

SPI2_PUSHR is 400A_C000h base + 34h offset = 400A_C034h

Bit	31	30	29	28	27	26	25	24	23	22	21	20	19	18	17	16	15	14	13	12	11	10	9	8	7	6	5	4	3	2	1	0
R							0		0																							
W	CONT	CTAS			EOQ	CTCNT						PCS[5:0]																				
Reset	0	0	0	0	0	0	0	0	0	0	0	0	0	0	0	0	0	0	0	0	0	0	0	0	0	0	0	0	0	0	0	

SPIx_PUSHR field descriptions

Field	Description
31 CONT	<p>Continuous Peripheral Chip Select Enable</p> <p>Selects a Continuous Selection Format. The bit is used in SPI master mode. The bit enables the selected PCS signals to remain asserted between transfers.</p> <p>0 Return PCSn signals to their inactive state between transfers. 1 Keep PCSn signals asserted between transfers.</p>
30–28 CTAS	<p>Clock and Transfer Attributes Select.</p> <p>Selects which CTAR register to use in master mode to specify the transfer attributes for the associated SPI frame. In SPI slave mode, CTAR0 is used. See the Chip Configuration chapter to determine how many CTAR registers this device has. You should not program a value in this field for a register that is not present.</p> <p>000 CTAR0 001 CTAR1 010 Reserved 011 Reserved 100 Reserved 101 Reserved</p>

Table continues on the next page...

SPIx_PUSHR field descriptions (continued)

Field	Description
	110 Reserved 111 Reserved
27 EOQ	End Of Queue Host software uses this bit to signal to the DSPI that the current SPI transfer is the last in a queue. At the end of the transfer, the EOQF bit in the SR is set. 0 The SPI data is not the last data to transfer. 1 The SPI data is the last data to transfer.
26 CTCNT	Clear Transfer Counter. Clears the SPI_TCNT field in the TCR register. The SPI_TCNT field is cleared before the DSPI starts transmitting the current SPI frame. 0 Do not clear the TCR[SPI_TCNT] field. 1 Clear the TCR[SPI_TCNT] field.
25–24 Reserved	This read-only field is reserved and always has the value zero.
23–22 Reserved	This read-only field is reserved and always has the value zero.
21–16 PCS[5:0]	Select which PCS signals are to be asserted for the transfer. Refer to the chip configuration chapter for the number of PCS signals used in this MCU. 0 Negate the PCS[x] signal. 1 Assert the PCS[x] signal.
15–0 TXDATA	Transmit Data Holds SPI data to be transferred according to the associated SPI command.

45.3.8 DSPI PUSH TX FIFO Register In Slave Mode (SPIx_PUSHR_SLAVE)

PUSHR provides the means to write to the TX FIFO. Data written to this register is transferred to the TX FIFO. Eight- or sixteen-bit write accesses to the PUSHR transfer all 32 register bits to the TX FIFO. The register structure is different in master and slave modes. In master mode the register provides 16-bit command and 16-bit data to the TX FIFO. In slave mode all 32 register bits can be used as data, supporting up to 32-bit SPI frame operation.

Addresses: SPI0_PUSHR_SLAVE is 4002_C000h base + 34h offset = 4002_C034h
 SPI1_PUSHR_SLAVE is 4002_D000h base + 34h offset = 4002_D034h
 SPI2_PUSHR_SLAVE is 400A_C000h base + 34h offset = 400A_C034h

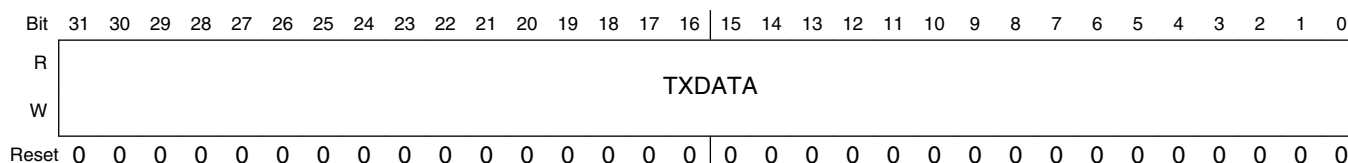

SPIx_PUSHR_SLAVE field descriptions

Field	Description
31–0 TXDATA	Transmit Data Holds SPI data to be transferred according to the associated SPI command.

45.3.9 DSPI POP RX FIFO Register (SPIx_POPR)

POPR is used to read the RX FIFO. Eight- or sixteen-bit read accesses to the POPR have the same effect on the RX FIFO as 32-bit read accesses. A write to this register will generate a Transfer Error.

Addresses: SPI0_POPR is 4002_C000h base + 38h offset = 4002_C038h
 SPI1_POPR is 4002_D000h base + 38h offset = 4002_D038h
 SPI2_POPR is 400A_C000h base + 38h offset = 400A_C038h

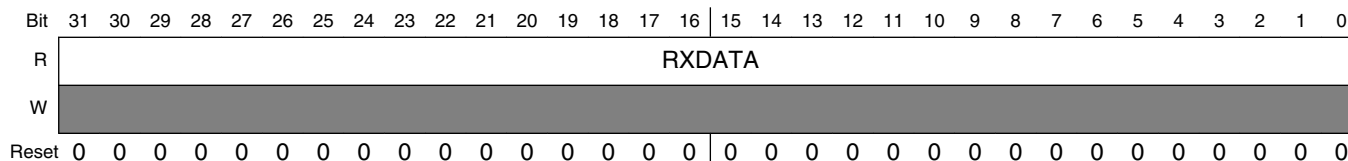

SPIx_POPR field descriptions

Field	Description
31–0 RXDATA	Received Data Contains the SPI data from the RX FIFO entry to which the Pop Next Data Pointer points.

45.3.10 DSPI Transmit FIFO Registers (SPIx_TXFRn)

TXFRn provide visibility into the TX FIFO for debugging purposes. Each register is an entry in the TX FIFO. The registers are read-only and cannot be modified. Reading the TXFRx registers does not alter the state of the TX FIFO.

Addresses: SPI0_TXFR0 is 4002_C000h base + 3Ch offset = 4002_C03Ch

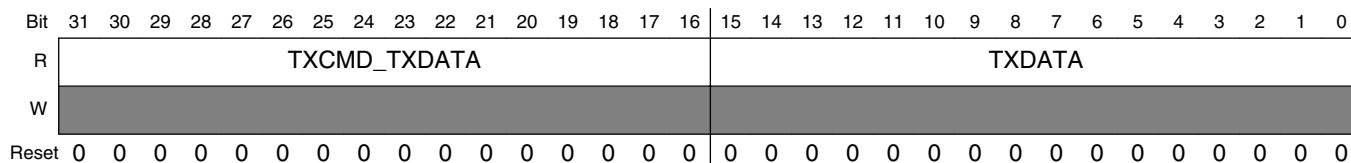

SPIx_TXFRn field descriptions

Field	Description
31–16 TXCMD_ TXDATA	Transmit Command or Transmit Data In master mode the TXCMD field contains the command that sets the transfer attributes for the SPI data. In slave mode, the TXDATA contains 16 MSB bits of the SPI data to be shifted out.
15–0 TXDATA	Transmit Data Contains the SPI data to be shifted out.

45.3.11 DSPI Receive FIFO Registers (SPIx_RXFRn)

RXFRn provide visibility into the RX FIFO for debugging purposes. Each register is an entry in the RX FIFO. The RXFR registers are read-only. Reading the RXFRx registers does not alter the state of the RX FIFO.

Addresses: SPI0_RXFR0 is 4002_C000h base + 7Ch offset = 4002_C07Ch

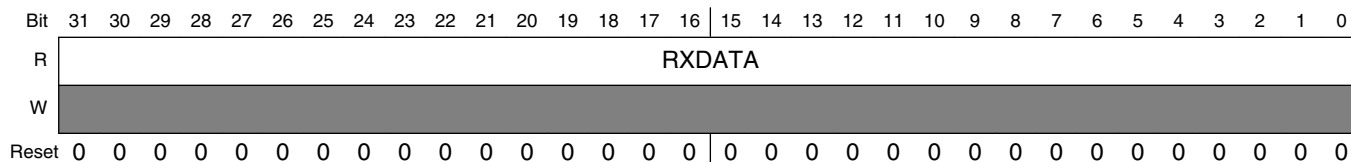

SPIx_RXFRn field descriptions

Field	Description
31–0 RXDATA	Receive Data Contains the received SPI data.

45.4 Functional Description

The Serial Peripheral Interface (DSPI) block supports full-duplex, synchronous serial communications between MCUs and peripheral devices. All communications are done with SPI-like protocol.

The DSPI has the following configurations:

- SPI Configuration in which the DSPI operates as a basic SPI or a queued SPI.

The DCONF field in the DSPI Module Configuration Register (MCR) determines the DSPI Configuration. See for the DSPI configuration values.

The CTARn registers hold clock and transfer attributes. The SPI configuration allows to select which CTAR to use on a frame by frame basis by setting a field in the SPI command. See DSPI Clock and Transfer Attributes Registers for information on the fields of the CTAR registers.

Typical master to slave connections are shown in the following figure. When a data transfer operation is performed, data is serially shifted a predetermined number of bit positions. Because the modules are linked, data is exchanged between the master and the slave. The data that was in the master shift register is now in the shift register of the slave, and vice versa. At the end of a transfer, the TCF bit in the SR is set to indicate a completed transfer.

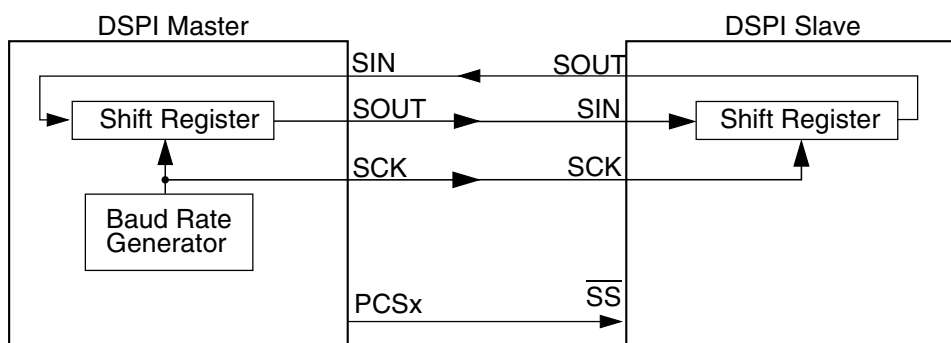

Figure 45-91. SPI Serial Protocol Overview

Generally more than one slave device can be connected to the DSPI master. 6 Peripheral Chip Select (PCS) signals of the DSPI masters can be used to select which of the slaves to communicate with. Refer to the chip configuration chapter for the number of PCS signals used in this MCU.

The three DSPI configurations share transfer protocol and timing properties which are described independently of the configuration in [Transfer Formats](#). The transfer rate and delay settings are described in [DSPI Baud Rate and Clock Delay Generation](#).

45.4.1 Start and Stop of DSPI Transfers

The DSPI has two operating states: STOPPED and RUNNING. The states are independent of DSPI configuration. The default state of the DSPI is STOPPED. In the STOPPED state no serial transfers are initiated in master mode and no transfers are responded to in slave mode. The STOPPED state is also a safe state for writing the various configuration registers of the DSPI without causing undetermined results. In the RUNNING state serial transfers take place.

The TXRXS bit in the SR indicates what state the DSPI in. The bit is set if the module in RUNNING state.

The DSPI is started (DSPI transitions to RUNNING) when all of the following conditions are true:

- SR[EOQF] bit is clear
- MCU is not in the debug mode or the MCR[FRZ] bit is clear
- MCR[HALT] bit is clear

The DSPI stops (transitions from RUNNING to STOPPED) after the current frame when any one of the following conditions exist:

- SR[EOQF] bit is set
- MCU in the debug mode and the MCR[FRZ] bit is set
- MCR[HALT] bit is set

State transitions from RUNNING to STOPPED occur on the next frame boundary if a transfer is in progress, or immediately if no transfers are in progress.

45.4.2 Serial Peripheral Interface (SPI) Configuration

The SPI Configuration transfers data serially using a shift register and a selection of programmable transfer attributes. The DSPI is in SPI Configuration when the DCONF field in the MCR is 0b00. The SPI frames can be 32 bits long. The host CPU or a DMA controller transfers the SPI data from the external to DSPI RAM queues to a transmit FIFO (TX FIFO) buffer. The received data is stored in entries in the Receive FIFO (RX FIFO) buffer. The host CPU or the DMA controller transfers the received data from the RX FIFO to memory external to the DSPI. The FIFO buffers operation is described in [Transmit First In First Out \(TX FIFO\) Buffering Mechanism](#), and [Receive First In First Out \(RX FIFO\) Buffering Mechanism](#). The interrupt and DMA request conditions are described in [Interrupts/DMA Requests](#).

The SPI Configuration supports two block-specific modes —master mode and slave mode. The FIFO operations are similar for both modes. The main difference is that in master mode the DSPI initiates and controls the transfer according to the fields in the SPI command field of the TX FIFO entry. In slave mode, the DSPI only responds to transfers initiated by a bus master external to the DSPI and the SPI command field space is used for 16 most significant bit of the transmit data.

45.4.2.1 Master Mode

In SPI master mode the DSPI initiates the serial transfers by controlling the Serial Communications Clock (SCK) and the Peripheral Chip Select (PCS) signals. The SPI command field in the executing TX FIFO entry determines which CTAR registers will be used to set the transfer attributes and which PCS signals to assert. The command field also contains various bits that help with queue management and transfer protocol. See DSPI PUSH TX FIFO Register (PUSHR) for details on the SPI command fields. The data field in the executing TX FIFO entry is loaded into the shift register and shifted out on the Serial Out (SOUT) pin. In SPI master mode, each SPI frame to be transmitted has a command associated with it allowing for transfer attribute control on a frame by frame basis.

45.4.2.2 Slave Mode

In SPI slave mode the DSPI responds to transfers initiated by a SPI bus master. The DSPI does not initiate transfers. Certain transfer attributes such as clock polarity, clock phase and frame size must be set for successful communication with a SPI master. The SPI slave mode transfer attributes are set in the CTAR0. The data is shifted out with MSB first. Shifting out of LSB is not supported in this mode.

45.4.2.3 FIFO Disable Operation

The FIFO disable mechanisms allow SPI transfers without using the TX FIFO or RX FIFO. The DSPI operates as a double-buffered simplified SPI when the FIFOs are disabled. The FIFOs are disabled separately; setting the MCR[DIS_TXF] bit disables the TX FIFO, and setting the MCR[DIS_RXF] bit disables the RX FIFO.

The FIFO Disable mechanisms are transparent to the user and to host software; Transmit data and commands are written to the PUSHHR and received data is read from the POPR.

When the TX FIFO is disabled the TFFF, TFUF and TXCTR fields in SR behave as if there is a one-entry FIFO but the contents of the TXFR registers and TXNXTPTR are undefined. Likewise, when the RX FIFO is disabled, the RFDF, RFOF and RXCTR fields in the SR behave as if there is a one-entry FIFO, but the contents of the RXFR registers and POPNXTPTR are undefined.

45.4.2.4 Transmit First In First Out (TX FIFO) Buffering Mechanism

The TX FIFO functions as a buffer of SPI data and SPI commands for transmission. The TX FIFO holds 4 words, each consisting of a command field and a data field. The number of entries in the TX FIFO is device-specific. SPI commands and data are added to the TX FIFO by writing to the DSPI PUSH TX FIFO Register (PUSHHR). TX FIFO entries can only be removed from the TX FIFO by being shifted out or by flushing the TX FIFO.

The TX FIFO Counter field (TXCTR) in the DSPI Status Register (SR) indicates the number of valid entries in the TX FIFO. The TXCTR is updated every time the DSPI_PUSHHR is written or SPI data is transferred into the shift register from the TX FIFO.

The TXNXTPTR field indicates which TX FIFO Entry will be transmitted during the next transfer. The TXNXTPTR contains the positive offset from TXFR0 in number of 32-bit registers. For example, TXNXTPTR equal to two means that the TXFR2 contains the SPI data and command for the next transfer. The TXNXTPTR field is incremented every time SPI data is transferred from the TX FIFO to the shift register. The maximum value of the field is equal to the maximum implemented TXFR register number and it rolls over after reaching the maximum.

45.4.2.4.1 Filling the TX FIFO

Host software or other intelligent blocks can add (push) entries to the TX FIFO by writing to the PUSHHR. When the TX FIFO is not full, the TX FIFO Fill Flag (TFFF) in the SR is set. The TFFF bit is cleared when TX FIFO is full and the DMA controller indicates that a write to PUSHHR is complete. Writing a '1' to the TFFF bit also clears it. The TFFF can generate a DMA request or an interrupt request. See [Transmit FIFO Fill Interrupt or DMA Request](#) for details.

The DSPI ignores attempts to push data to a full TX FIFO, the state of the TX FIFO does not change and no error condition is indicated.

45.4.2.4.2 Draining the TX FIFO

The TX FIFO entries are removed (drained) by shifting SPI data out through the shift register. Entries are transferred from the TX FIFO to the shift register and shifted out as long as there are valid entries in the TX FIFO. Every time an entry is transferred from the TX FIFO to the shift register, the TX FIFO Counter decrements by one. At the end of a transfer, the TCF bit in the SR is set to indicate the completion of a transfer. The TX FIFO is flushed by writing a '1' to the CLR_TXF bit in MCR.

If an external bus master initiates a transfer with a DSPI slave while the slave's DSPI TX FIFO is empty, the Transmit FIFO Underflow Flag (TFUF) in the slave's SR is set. See [Transmit FIFO Underflow Interrupt Request](#) for details.

45.4.2.5 Receive First In First Out (RX FIFO) Buffering Mechanism

The RX FIFO functions as a buffer for data received on the SIN pin. The RX FIFO holds 4 received SPI data frames. The number of entries in the RX FIFO is device-specific. SPI data is added to the RX FIFO at the completion of a transfer when the received data in the shift register is transferred into the RX FIFO. SPI data are removed (popped) from the RX FIFO by reading the DSPI POP RX FIFO Register (POPR). RX FIFO entries can only be removed from the RX FIFO by reading the POPR or by flushing the RX FIFO.

The RX FIFO Counter field (RXCTR) in the DSPI Status Register (SR) indicates the number of valid entries in the RX FIFO. The RXCTR is updated every time the POPR is read or SPI data is copied from the shift register to the RX FIFO.

The POPNXTPTR field in the SR points to the RX FIFO entry that is returned when the POPR is read. The POPNXTPTR contains the positive offset from RXFR0 in number of 32-bit registers. For example, POPNXTPTR equal to two means that the RXFR2 contains the received SPI data that will be returned when POPR is read. The POPNXTPTR field is

incremented every time the POPR is read. The maximum value of the field is equal to the maximum implemented RXFR register number and it rolls over after reaching the maximum.

45.4.2.5.1 Filling the RX FIFO

The RX FIFO is filled with the received SPI data from the shift register. While the RX FIFO is not full, SPI frames from the shift register are transferred to the RX FIFO. Every time a SPI frame is transferred to the RX FIFO the RX FIFO Counter is incremented by one.

If the RX FIFO and shift register are full and a transfer is initiated, the RFOF bit in the SR is set indicating an overflow condition. Depending on the state of the ROOE bit in the MCR, the data from the transfer that generated the overflow is either ignored or shifted in to the shift register. If the ROOE bit is set, the incoming data is shifted in to the shift register. If the ROOE bit is cleared, the incoming data is ignored.

45.4.2.5.2 Draining the RX FIFO

Host CPU or a DMA can remove (pop) entries from the RX FIFO by reading the DSPI POP RX FIFO Register (POPR). A read of the POPR decrements the RX FIFO Counter by one. Attempts to pop data from an empty RX FIFO are ignored and the RX FIFO Counter remains unchanged. The data, read from the empty RX FIFO, is undetermined.

When the RX FIFO is not empty, the RX FIFO Drain Flag (RFDF) in the SR is set. The RFDF bit is cleared when the RX_FIFO is empty and the DMA controller indicates that a read from POPR is complete or by writing a '1' to it.

45.4.3 DSPI Baud Rate and Clock Delay Generation

The SCK frequency and the delay values for serial transfer are generated by dividing the system clock frequency by a prescaler and a scaler with the option for doubling the baud rate. The following figure shows conceptually how the SCK signal is generated.

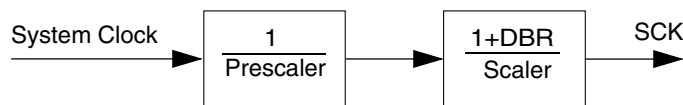

Figure 45-92. Communications Clock Prescalers and Scalers

45.4.3.1 Baud Rate Generator

The Baud Rate is the frequency of the Serial Communication Clock (SCK). The system clock is divided by a prescaler (PBR) and scaler (BR) to produce SCK with the possibility of halving the scaler division. The DBR, PBR and BR fields in the CTAR registers select the frequency of SCK by the formula in the BR field description. The following table shows an example of how to compute the baud rate.

Table 45-106. Baud Rate Computation Example

f_{sys}	PBR	Prescaler	BR	Scaler	DBR	Baud Rate
100 MHz	0b00	2	0b0000	2	0	25 Mb/s
20 MHz	0b00	2	0b0000	2	1	10 Mb/s

NOTE

The clock frequencies mentioned in the preceding table are given as an example. Refer to the clocking chapter for the frequency used to drive this module in the device.

45.4.3.2 PCS to SCK Delay (t_{csc})

The PCS to SCK delay is the length of time from assertion of the PCS signal to the first SCK edge. See [Figure 45-94](#) for an illustration of the PCS to SCK delay. The PCSSCK and CSSCK fields in the CTAR_x registers select the PCS to SCK delay by the formula in the CSSCK field description. The following table shows an example of how to compute the PCS to SCK delay.

Table 45-107. PCS to SCK Delay Computation Example

f_{sys}	PCSSCK	Prescaler	CSSCK	Scaler	PCS to SCK Delay
100 MHz	0b01	3	0b0100	32	0.96 μ s

NOTE

The clock frequency mentioned in the preceding table is given as an example. Refer to the clocking chapter for the frequency used to drive this module in the device.

45.4.3.3 After SCK Delay (t_{ASC})

The After SCK Delay is the length of time between the last edge of SCK and the negation of PCS. See [Figure 45-94](#) and [Figure 45-95](#) for illustrations of the After SCK delay. The PASC and ASC fields in the CTAR x registers select the After SCK Delay by the formula in the ASC field description. The following table shows an example of how to compute the After SCK delay.

Table 45-108. After SCK Delay Computation Example

f_{sys}	PASC	Prescaler	ASC	Scaler	After SCK Delay
100 MHz	0b01	3	0b0100	32	0.96 μ s

NOTE

The clock frequency mentioned in the preceding table is given as an example. Refer to the clocking chapter for the frequency used to drive this module in the device.

45.4.3.4 Delay after Transfer (t_{DT})

The Delay after Transfer is the minimum time between negation of the PCS signal for a frame and the assertion of the PCS signal for the next frame. See [Figure 45-94](#) for an illustration of the Delay after Transfer. The PDT and DT fields in the CTAR x registers select the Delay after Transfer by the formula in the DT field description. The following table shows an example of how to compute the Delay after Transfer.

Table 45-109. Delay after Transfer Computation Example

f_{sys}	PDT	Prescaler	DT	Scaler	Delay after Transfer
100 MHz	0b01	3	0b1110	32768	0.98 ms

NOTE

The clock frequency mentioned in the preceding table is given as an example. Refer to the clocking chapter for the frequency used to drive this module in the device.

When in non-continuous clock mode the t_{DT} delay is configured according to the equation specified in the CTAR[DT] bitfield description. When in continuous clock mode, the delay is fixed at 1 SCK period.

45.4.3.5 Peripheral Chip Select Strobe Enable ($\overline{\text{PCSS}}$)

The $\overline{\text{PCSS}}$ signal provides a delay to allow the PCS signals to settle after a transition occurs thereby avoiding glitches. When the DSPI is in master mode and the PCSSE bit is set in the MCR, $\overline{\text{PCSS}}$ provides a signal for an external demultiplexer to decode the PCS[0] - PCS[4] signals into as many as 128 glitch-free PCS signals. The following figure shows the timing of the $\overline{\text{PCSS}}$ signal relative to PCS signals.

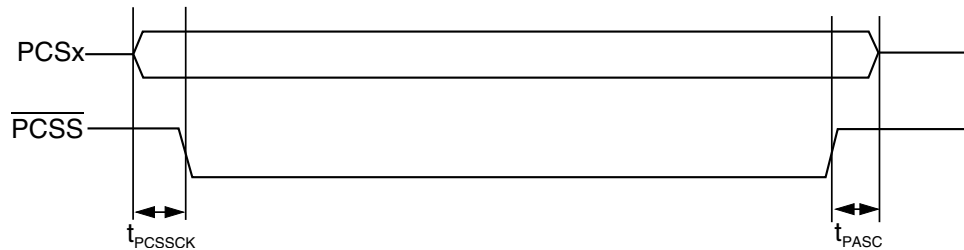

Figure 45-93. Peripheral Chip Select Strobe Timing

The delay between the assertion of the PCS signals and the assertion of $\overline{\text{PCSS}}$ is selected by the PCSSCK field in the CTAR based on the following formula:

$$t_{\text{PCSSCK}} = \frac{1}{f_{\text{SYS}}} \times \text{PCSSCK}$$

At the end of the transfer the delay between $\overline{\text{PCSS}}$ negation and PCS negation is selected by the PASC field in the CTAR based on the following formula:

$$t_{\text{PASC}} = \frac{1}{f_{\text{SYS}}} \times \text{PASC}$$

The following table shows an example of how to compute the t_{pcssck} delay.

Table 45-110. Peripheral Chip Select Strobe Assert Computation Example

f_{sys}	PCSSCK	Prescaler	Delay before Transfer
100 MHz	0b11	7	70.0 ns

The following table shows an example of how to compute the t_{pasc} delay.

Table 45-111. Peripheral Chip Select Strobe Negate Computation Example

f_{sys}	PASC	Prescaler	Delay after Transfer
100 MHz	0b11	7	70.0 ns

The $\overline{\text{PCSS}}$ signal is not supported when Continuous Serial Communication SCK mode are enabled.

NOTE

The clock frequency mentioned in the preceding tables is given as an example. Refer to the clocking chapter for the frequency used to drive this module in the device.

45.4.4 Transfer Formats

The SPI serial communication is controlled by the Serial Communications Clock (SCK) signal and the PCS signals. The SCK signal provided by the master device synchronizes shifting and sampling of the data on the SIN and SOUT pins. The PCS signals serve as enable signals for the slave devices.

In master mode, the CPOL and CPHA bits in the Clock and Transfer Attributes Registers (CTARn) select the polarity and phase of the serial clock, SCK.

- CPOL - Selects the idle state polarity of the SCK
- CPHA - Selects if the data on SOUT is valid before or on the first SCK edge

Even though the bus slave does not control the SCK signal, in slave mode these values must be identical to the master device settings to ensure proper transmission. In SPI slave mode, only CTAR0 is used.

The DSPI supports four different transfer formats:

- Classic SPI with CPHA=0
- Classic SPI with CPHA=1
- Modified Transfer format with CPHA = 0
- Modified Transfer format with CPHA = 1

A modified transfer format is supported to allow for high-speed communication with peripherals that require longer setup times. The DSPI can sample the incoming data later than halfway through the cycle to give the peripheral more setup time. The MTFE bit in the MCR selects between Classic SPI Format and Modified Transfer Format.

In the SPI Configurations, the DSPI provides the option of keeping the PCS signals asserted between frames. See [Continuous Selection Format](#) for details.

45.4.4.1 Classic SPI Transfer Format (CPHA = 0)

The transfer format shown in following figure is used to communicate with peripheral SPI slave devices where the first data bit is available on the first clock edge. In this format, the master and slave sample their SIN pins on the odd-numbered SCK edges and change the data on their SOUT pins on the even-numbered SCK edges.

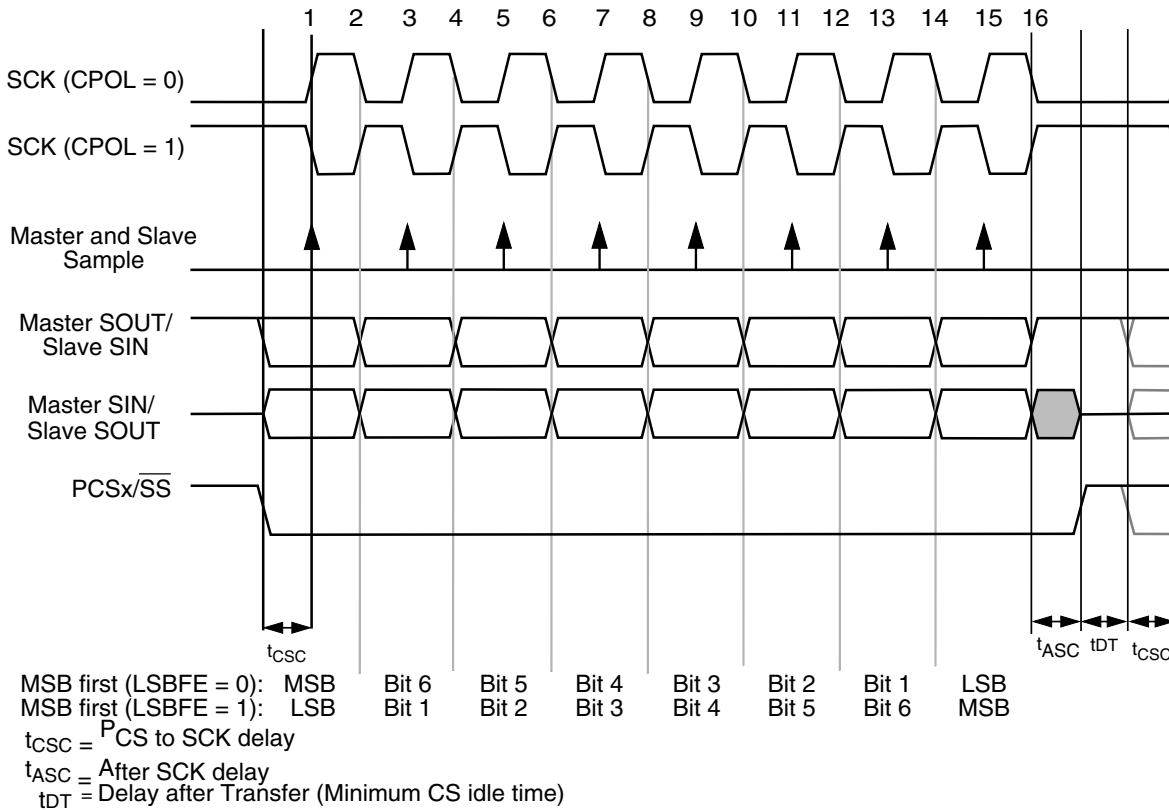

Figure 45-94. DSPI Transfer Timing Diagram (MTFE=0, CPHA=0, FMSZ=8)

The master initiates the transfer by placing its first data bit on the SOUT pin and asserting the appropriate peripheral chip select signals to the slave device. The slave responds by placing its first data bit on its SOUT pin. After the t_{CSC} delay elapses, the master outputs the first edge of SCK. The master and slave devices use this edge to sample the first input data bit on their serial data input signals. At the second edge of the SCK the master and slave devices place their second data bit on their serial data output signals. For the rest of the frame the master and the slave sample their SIN pins on the odd-numbered clock edges and changes the data on their SOUT pins on the even-numbered clock edges. After the last clock edge occurs a delay of t_{ASC} is inserted before the master negates the PCS signals. A delay of t_{DT} is inserted before a new frame transfer can be initiated by the master.

45.4.4.2 Classic SPI Transfer Format (CPHA = 1)

This transfer format shown in the following figure is used to communicate with peripheral SPI slave devices that require the first SCK edge before the first data bit becomes available on the slave SOUT pin. In this format the master and slave devices change the data on their SOUT pins on the odd-numbered SCK edges and sample the data on their SIN pins on the even-numbered SCK edges

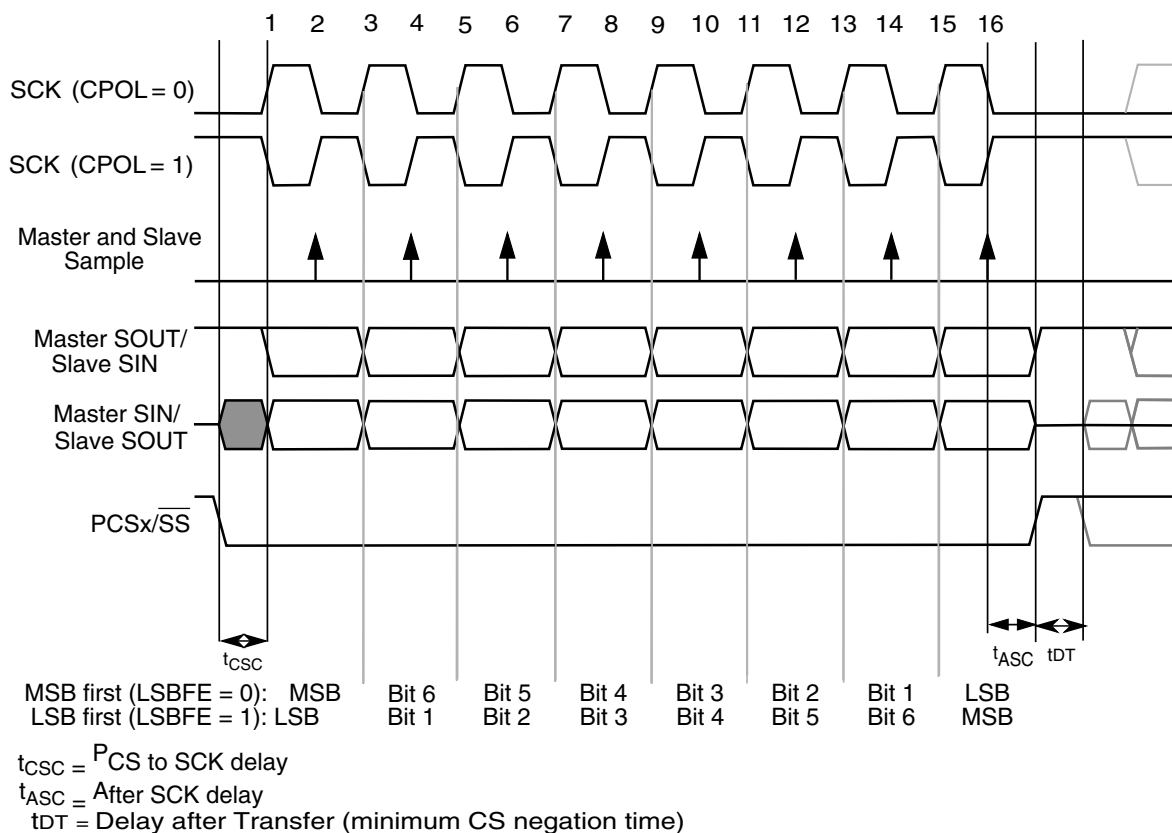

Figure 45-95. DSPI Transfer Timing Diagram (MTFE=0, CPHA=1, FMSZ=8)

The master initiates the transfer by asserting the PCS signal to the slave. After the t_{CSC} delay has elapsed, the master generates the first SCK edge and at the same time places valid data on the master SOUT pin. The slave responds to the first SCK edge by placing its first data bit on its slave SOUT pin.

At the second edge of the SCK the master and slave sample their SIN pins. For the rest of the frame the master and the slave change the data on their SOUT pins on the odd-numbered clock edges and sample their SIN pins on the even-numbered clock edges. After the last clock edge occurs a delay of t_{ASC} is inserted before the master negates the PCS signal. A delay of t_{DT} is inserted before a new frame transfer can be initiated by the master.

45.4.4.3 Continuous Selection Format

Some peripherals must be deselected between every transfer. Other peripherals must remain selected between several sequential serial transfers. The Continuous Selection Format provides the flexibility to handle the following case. The Continuous Selection Format is enabled for the SPI Configuration by setting the CONT bit in the SPI command. The behavior of the PCS signals in the configurations is identical so only SPI Configuration will be described.

When the CONT bit = 0, the DSPI drives the asserted Chip Select signals to their idle states in between frames. The idle states of the Chip Select signals are selected by the PCSISn bits in the MCR. The following timing diagram is for two four-bit transfers with CPHA = 1 and CONT = 0.

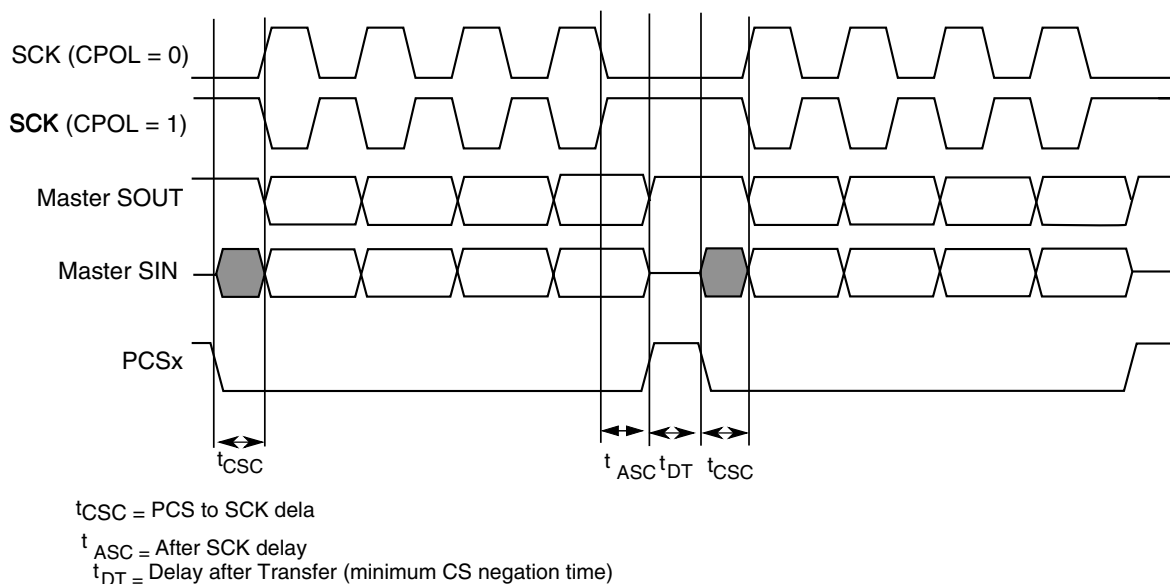

Figure 45-96. Example of Non-Continuous Format (CPHA=1, CONT=0)

When the CONT bit = 1, the PCS signal remains asserted for the duration of the two transfers. The Delay between Transfers (t_{DT}) is not inserted between the transfers. The following figure shows the timing diagram for two four-bit transfers with CPHA = 1 and CONT = 1.

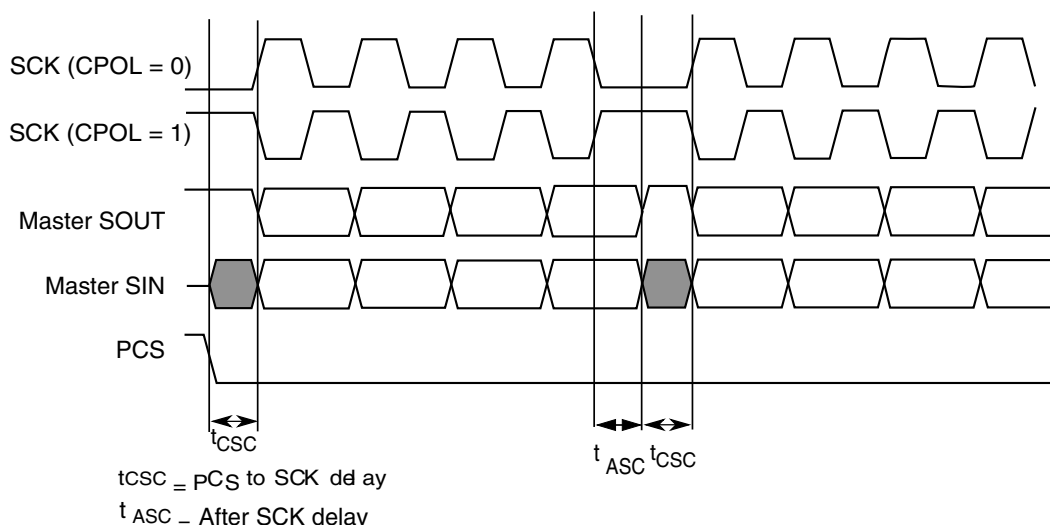

Figure 45-97. Example of Continuous Transfer (CPHA=1, CONT=1)

When using DSPI with continuous selection follow these rules:

- All transmit commands must have the same PCSn bits programming.
- The CTARs, selected by transmit commands, must be programmed with the same transfer attributes. Only FMSZ field can be programmed differently in these CTARs.
- When transmitting multiple frames in this mode, the user software must ensure that the last frame has the PUSHR[CONT] bit de-asserted (in master mode) and the user software must provide sufficient frames in the TX_FIFO to be sent out (in slave mode) and the master de-asserts the PCSn at end of transmission of last frame.
- The PUSHR[CONT] / DSICR0[DCONT] bits must be de-asserted before asserting MCR[HALT] bit (in master mode). This will make sure that the PCSn signals are de-asserted. Asserting MCR[HALT] bit during continuous transfer will cause the PCSn signals to remain asserted and hence Slave Device cannot transition from RUNNING to STOPPED state.

NOTE

User must fill the TXFIFO with the number of entries that will be concatenated together under one PCS assertion for both master and slave before the TXFIFO becomes empty.

When operating in slave mode, ensure that when the last-entry in the TXFIFO is completely transmitted (that is the corresponding TCF flag is asserted and TXFIFO is empty), the slave is deselected for any further serial communication; otherwise, an underflow error occurs.

45.4.5 Continuous Serial Communications Clock

The DSPI provides the option of generating a continuous SCK signal for slave peripherals that require a continuous clock.

Continuous SCK is enabled by setting the CONT_SCKE bit in the MCR. Enabling this bit generates the Continuous Serial Communications Clock regardless of the MCR[HALT] bit status.. Continuous SCK is valid in all configurations.

Continuous SCK is only supported for CPHA=1. Clearing CPHA is ignored if the CONT_SCKE bit is set. Continuous SCK is supported for Modified Transfer Format.

Clock and transfer attributes for the Continuous SCK mode are set according to the following rules:

- When the DSPI is in SPI configuration, CTAR0 is used initially. At the start of each SPI frame transfer, the CTAR specified by the CTAS for the frame is used.
- In all configurations, the currently selected CTAR remains in use until the start of a frame with a different CTAR specified, or the Continuous SCK mode is terminated.

It is recommended to keep the baud rate the same while using the Continuous SCK. Switching clock polarity between frames while using Continuous SCK can cause errors in the transfer. Continuous SCK operation is not guaranteed if the DSPI is put into the External Stop mode or Module Disable mode.

Enabling Continuous SCK disables the PCS to SCK delay and the Delay after Transfer (t_{DT}) is fixed to one SCK cycle. The following figure is the timing diagram for Continuous SCK format with Continuous Selection disabled.

NOTE

When in Continuous SCK mode, for the SPI transfer CTAR0 should always be used, and the TXFIFO must be cleared using the MCR[CLR_TXF] field before initiating transfer.

functional Description

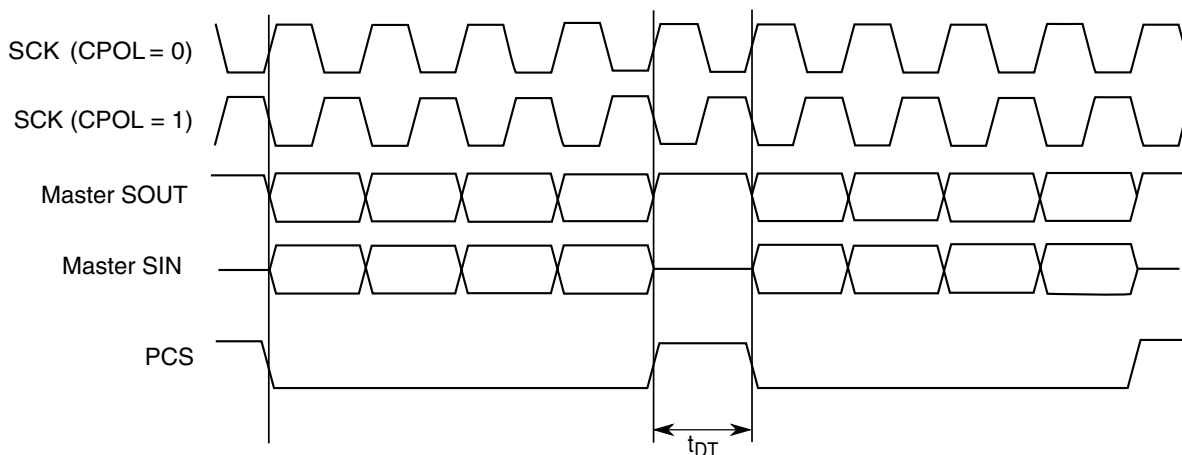

Figure 45-98. Continuous SCK Timing Diagram (CONT=0)

If the CONT bit in the TX FIFO entry is set, PCS remains asserted between the transfers. Under certain conditions, SCK can continue with PCS asserted, but with no data being shifted out of SOUT (SOUT pulled high). This can cause the slave to receive incorrect data. Those conditions include:

- Continuous SCK with CONT bit set, but no data in the transmit FIFO.
- Continuous SCK with CONT bit set and entering STOPPED state (refer to [Start and Stop of DSPI Transfers](#)).
- Continuous SCK with CONT bit set and entering Stop mode or Module Disable mode.

The following figure shows timing diagram for Continuous SCK format with Continuous Selection enabled.

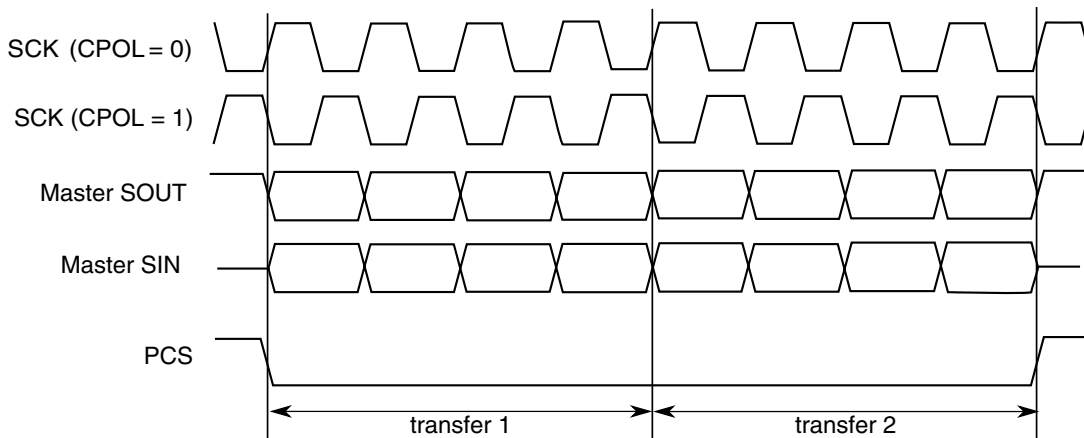

Figure 45-99. Continuous SCK Timing Diagram (CONT=1)

45.4.6 Slave Mode Operation Constraints

Slave mode logic shift register is buffered. This allows data streaming operation, when the DSPI is permanently selected and data is shifted in with a constant rate.

The transmit data is transferred at second SCK clock edge of the each frame to the shift register if the \overline{SS} signal is asserted and any time when transmit data is ready and \overline{SS} signal is negated.

Received data is transferred to the receive buffer at last SCK edge of each frame, defined by frame size programmed to the CTAR0/1 register. Then the data from the buffer is transferred to the RXFIFO or DDR register.

If the \overline{SS} negates before that last SCK edge, the data from shift register is lost.

This buffering scheme allows to operate slave clock with higher frequency than the system frequency. The clocks relationship is defined by the following equation. *FrameSize* is the value of the CTAR0/1[FMSZ] field plus one.

$$f_{SCK} < f_{SYS} \times \text{FrameSize} / 3$$

45.4.7 Interrupts/DMA Requests

The DSPI has several conditions that can only generate interrupt requests and two conditions that can generate interrupt or DMA requests. The following table lists these conditions.

Table 45-112. Interrupt and DMA Request Conditions

Condition	Flag	Interrupt	DMA
End of Queue (EOQ)	EOQF	Yes	
TX FIFO Fill	TFFF	Yes	Yes
Transfer Complete	TCF	Yes	
TX FIFO Underflow	TFUF	Yes	
RX FIFO Drain	RFDF	Yes	Yes
RX FIFO Overflow	RFOF	Yes	

Each condition has a flag bit in the DSPI Status Register (SR) and an Request Enable bit in the DSPI DMA/Interrupt Request Select and Enable Register (RSER). The TX FIFO Fill Flag (TFFF) and RX FIFO Drain Flag (RFDF) generate interrupt requests or DMA requests depending on the TFFF_DIRS and RFDF_DIRS bits in the RSER.

The DSPI module also provides a global interrupt request line, which is asserted when any of individual interrupt requests lines is asserted.

45.4.7.1 End of Queue Interrupt Request

The End of Queue Request indicates that the end of a transmit queue is reached. The End of Queue Request is generated when the EOQ bit in the executing SPI command is set and the EOQF_RE bit in the RSER is set.

NOTE

This interrupt request is generated when the last bit of the SPI frame with EOQ bit set is transmitted.

45.4.7.2 Transmit FIFO Fill Interrupt or DMA Request

The Transmit FIFO Fill Request indicates that the TX FIFO is not full. The Transmit FIFO Fill Request is generated when the number of entries in the TX FIFO is less than the maximum number of possible entries, and the TFFF_RE bit in the RSER is set. The TFFF_DIRS bit in the RSER selects whether a DMA request or an interrupt request is generated.

NOTE

TFFF flag clears automatically when DMA is used to fill TXFIFO.

To clear TFFF when not using DMA, follow these steps for every PUSH performed using CPU to fill TXFIFO:

1. Wait until TFFF = 1
2. Write data to PUSHR using CPU.
3. Clear TFFF by writing a 1 to its location. If FIFO is not full, this flag will not clear.

45.4.7.3 Transfer Complete Interrupt Request

The Transfer Complete Request indicates the end of the transfer of a serial frame. The Transfer Complete Request is generated at the end of each frame transfer when the TCF_RE bit is set in the RSER.

45.4.7.4 Transmit FIFO Underflow Interrupt Request

The Transmit FIFO Underflow Request indicates that an underflow condition in the TX FIFO has occurred. The transmit underflow condition is detected only for the DSPI, operating in slave mode and SPI configuration. The TFUF bit is set when the TX FIFO of a DSPI is empty, and a transfer is initiated from an external SPI master. If the TFUF bit is set while the TFUF_RE bit in the RSER is set, an interrupt request is generated.

45.4.7.5 Receive FIFO Drain Interrupt or DMA Request

The Receive FIFO Drain Request indicates that the RX FIFO is not empty. The Receive FIFO Drain Request is generated when the number of entries in the RX FIFO is not zero, and the RFDF_RE bit in the RSER is set. The RFDF_DIRS bit in the RSER selects whether a DMA request or an interrupt request is generated.

45.4.7.6 Receive FIFO Overflow Interrupt Request

The Receive FIFO Overflow Request indicates that an overflow condition in the RX FIFO has occurred. A Receive FIFO Overflow request is generated when RX FIFO and shift register are full and a transfer is initiated. The RFOF_RE bit in the RSER must be set for the interrupt request to be generated.

Depending on the state of the ROOE bit in the MCR, the data from the transfer that generated the overflow is either ignored or shifted in to the shift register. If the ROOE bit is set, the incoming data is shifted in to the shift register. If the ROOE bit is cleared, the incoming data is ignored.

45.4.8 Power Saving Features

The DSPI supports following power-saving strategies:

- External Stop mode
- Module Disable mode - Clock gating of non-memory mapped logic

45.4.8.1 Stop Mode (External Stop Mode)

The DSPI supports the stop mode protocol. When a request is made to enter external stop mode, the DSPI block acknowledges the request. If a serial transfer is in progress, the DSPI waits until it reaches the frame boundary before it is ready to have its clocks shut off. While the clocks are shut off, the DSPI memory-mapped logic is not accessible. The states of the interrupt and DMA request signals cannot be changed while in External Stop mode.

45.4.8.2 Module Disable Mode

Module disable mode is a block-specific mode that the DSPI can enter to save power. Host CPU can initiate the module disable mode by setting the MDIS bit in the MCR. The module disable mode can also be initiated by hardware. A power management block can initiate the module disable mode by asserting the DOZE mode signal while the DOZE bit in the MCR is set.

When the MDIS bit is set or the DOZE mode signal is asserted while the DOZE bit is set, the DSPI negates Clock Enable signal at the next frame boundary. If implemented, the Clock Enable signal can stop the clock to the non-memory mapped logic. When Clock Enable is negated, the DSPI is in a dormant state, but the memory mapped registers are still accessible. Certain read or write operations have a different effect when the DSPI is in the module disable mode. Reading the RX FIFO Pop Register does not change the state of the RX FIFO. Likewise, writing to the TX FIFO Push Register does not change the state of the TX FIFO. Clearing either of the FIFOs has no effect in the module disable mode. Changes to the DIS_TXF and DIS_RXF fields of the MCR have no effect in the module disable mode. In the module disable mode, all status bits and register flags in the DSPI return the correct values when read, but writing to them has no effect. Writing to the TCR during module disable mode has no effect. Interrupt and DMA request signals cannot be cleared while in the module disable mode.

45.5 Initialization/Application Information

This section describes how to initialize the DSPI module.

45.5.1 How to Manage DSPI Queues

The queues are not part of the DSPI, but the DSPI includes features in support of queue management. Queues are primarily supported in SPI Configuration.

1. When DSPI executes last command word from a queue, the EOQ bit in the command word is set to indicate to the DSPI that this is the last entry in the queue.
2. At the end of the transfer, corresponding to the command word with EOQ set is sampled, the EOQ flag (EOQF) in the SR is set.
3. The setting of the EOQF flag disables serial transmission and reception of data, putting the DSPI in the STOPPED state. The TXRXS bit is cleared to indicate the STOPPED state.
4. The DMA can continue to fill TX FIFO until it is full or step 5 occurs.
5. Disable DSPI DMA transfers by disabling the DMA enable request for the DMA channel assigned to TX FIFO and RX FIFO. This is done by clearing the corresponding DMA enable request bits in the DMA Controller.
6. Ensure all received data in RX FIFO has been transferred to memory receive queue by reading the RXCNT in SR or by checking RFDF in the SR after each read operation of the POPR.
7. Modify DMA descriptor of TX and RX channels for new queues
8. Flush TX FIFO by writing a '1' to the CLR_TXF bit in the MCR. Flush RX FIFO by writing a '1' to the CLR_RXF bit in the MCR.
9. Clear transfer count either by setting CTCNT bit in the command word of the first entry in the new queue or via CPU writing directly to SPI_TCNT field in the TCR.
10. Enable DMA channel by enabling the DMA enable request for the DMA channel assigned to the DSPI TX FIFO, and RX FIFO by setting the corresponding DMA set enable request bit.
11. Enable serial transmission and serial reception of data by clearing the EOQF bit.

45.5.2 Switching Master and Slave Mode

When changing modes in the DSPI, follow the steps below to guarantee proper operation.

1. Halt the DSPI by setting MCR[HALT].
2. Clear the transmit and receive FIFOs by writing a 1 to the CLR_TXF and CLR_RXF bits in MCR.
3. Set the appropriate mode in MCR[MSTR] and enable the DSPI by clearing MCR[HALT].

45.5.3 Baud Rate Settings

The following table shows the baud rate that is generated based on the combination of the baud rate prescaler PBR and the baud rate scaler BR in the CTAR registers. The values calculated assume a 100 MHz system frequency and the double baud rate DBR bit is clear.

NOTE

The clock frequency mentioned above is given as an example in this chapter. Refer to the clocking chapter for the frequency used to drive this module in the device.

Table 45-113. Baud Rate Values (bps)

		Baud Rate Divider Prescaler Values			
		2	3	5	7
Baud Rate Scaler Values	2	25.0M	16.7M	10.0M	7.14M
	4	12.5M	8.33M	5.00M	3.57M
	6	8.33M	5.56M	3.33M	2.38M
	8	6.25M	4.17M	2.50M	1.79M
	16	3.12M	2.08M	1.25M	893k
	32	1.56M	1.04M	625k	446k
	64	781k	521k	312k	223k
	128	391k	260k	156k	112k
	256	195k	130k	78.1k	55.8k
	512	97.7k	65.1k	39.1k	27.9k
	1024	48.8k	32.6k	19.5k	14.0k
	2048	24.4k	16.3k	9.77k	6.98k
	4096	12.2k	8.14k	4.88k	3.49k
	8192	6.10k	4.07k	2.44k	1.74k
	16384	3.05k	2.04k	1.22k	872
32768	1.53k	1.02k	610	436	

45.5.4 Delay Settings

The following table shows the values for the Delay after Transfer (t_{DT}) and CS to SCK Delay (T_{CSC}) that can be generated based on the prescaler values and the scaler values set in the CTAR registers. The values calculated assume a 100 MHz system frequency.

NOTE

The clock frequency mentioned above is given as an example in this chapter. Refer to the clocking chapter for the frequency used to drive this module in the device.

Table 45-114. Delay Values

		Delay Prescaler Values			
		1	3	5	7
Delay Scaler Values	2	20.0 ns	60.0 ns	100.0 ns	140.0 ns
	4	40.0 ns	120.0 ns	200.0 ns	280.0 ns
	8	80.0 ns	240.0 ns	400.0 ns	560.0 ns
	16	160.0 ns	480.0 ns	800.0 ns	1.1 μ s
	32	320.0 ns	960.0 ns	1.6 μ s	2.2 μ s
	64	640.0 ns	1.9 μ s	3.2 μ s	4.5 μ s
	128	1.3 μ s	3.8 μ s	6.4 μ s	9.0 μ s
	256	2.6 μ s	7.7 μ s	12.8 μ s	17.9 μ s
	512	5.1 μ s	15.4 μ s	25.6 μ s	35.8 μ s
	1024	10.2 μ s	30.7 μ s	51.2 μ s	71.7 μ s
	2048	20.5 μ s	61.4 μ s	102.4 μ s	143.4 μ s
	4096	41.0 μ s	122.9 μ s	204.8 μ s	286.7 μ s
	8192	81.9 μ s	245.8 μ s	409.6 μ s	573.4 μ s
	16384	163.8 μ s	491.5 μ s	819.2 μ s	1.1 ms
	32768	327.7 μ s	983.0 μ s	1.6 ms	2.3 ms
65536	655.4 μ s	2.0 ms	3.3 ms	4.6 ms	

45.5.5 Calculation of FIFO Pointer Addresses

Complete visibility of the TX and RX FIFO contents is available through the FIFO registers, and valid entries can be identified through a memory mapped pointer and a memory mapped counter for each FIFO. The pointer to the first-in entry in each FIFO is memory mapped. For the TX FIFO the first-in pointer is the Transmit Next Pointer (TXNXTPTR). For the RX FIFO the first-in pointer is the Pop Next Pointer (POPXTPTR). The following figure illustrates the concept of first-in and last-in FIFO entries along with the FIFO Counter. The TX FIFO is chosen for the illustration, but the concepts carry over to the RX FIFO. See [Transmit First In First Out \(TX FIFO\) Buffering Mechanism](#) and [Receive First In First Out \(RX FIFO\) Buffering Mechanism](#) for details on the FIFO operation.

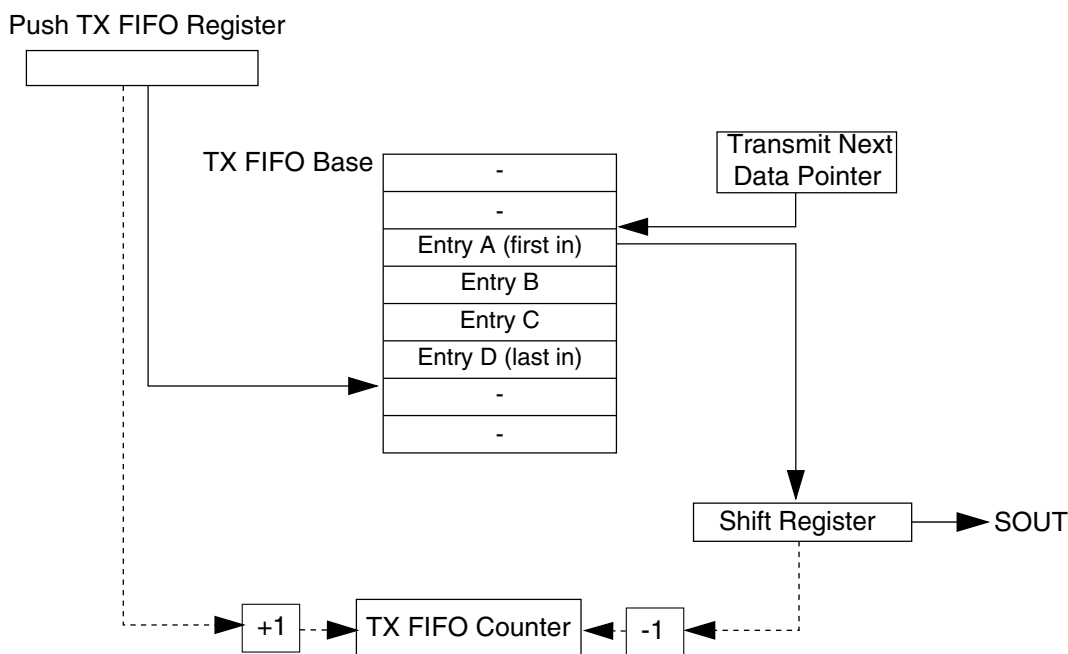

Figure 45-100. TX FIFO Pointers and Counter

45.5.5.1 Address Calculation for the First-in Entry and Last-in Entry in the TX FIFO

The memory address of the first-in entry in the TX FIFO is computed by the following equation:

$$\text{First-in EntryAddress} = \text{TXFIFOBase} + (4 \times \text{TXNXPTR})$$

The memory address of the last-in entry in the TX FIFO is computed by the following equation:

$$\text{Last-inEntryaddress} = \text{TXFIFOBase} + 4 \times (\text{TXCTR} + \text{TXNXPTR} - 1) \bmod (\text{TXFIFOdepth})$$

TX FIFO Base - Base address of TX FIFO

TXCTR - TX FIFO Counter

TXNXPTR - Transmit Next Pointer

TX FIFO Depth - Transmit FIFO depth, implementation specific

45.5.5.2 Address Calculation for the First-in Entry and Last-in Entry in the RX FIFO

The memory address of the first-in entry in the RX FIFO is computed by the following equation:

$$\text{First-in EntryAddress} = \text{RX FIFOBase} + (4 \times \text{POPNextPTR})$$

The memory address of the last-in entry in the RX FIFO is computed by the following equation:

$$\text{Last-inEntryaddress} = \text{RX FIFO Base} + 4 \times (\text{RXCTR} + \text{POPNextPTR} - 1) \bmod (\text{RXFIFOdepth})$$

RX FIFO Base - Base address of RX FIFO

RXCTR - RX FIFO counter

POPNextPTR - Pop Next Pointer

RX FIFO Depth - Receive FIFO depth, implementation specific

Chapter 46

Inter-Integrated Circuit (I2C)

46.1 Introduction

NOTE

For the chip-specific implementation details of this module's instances see the chip configuration chapter.

The inter-integrated circuit (I²C, I2C, or IIC) module provides a method of communication between a number of devices. The interface is designed to operate up to 100 kbit/s with maximum bus loading and timing. The device is capable of operating at higher baud rates, up to a maximum of clock/20, with reduced bus loading. The maximum communication length and the number of devices that can be connected are limited by a maximum bus capacitance of 400 pF. The I2C module also complies with the *System Management Bus (SMBus) Specification, version 2*.

46.1.1 Features

The I2C module has the following features:

- Compatible with *The I²C-Bus Specification*
- Multimaster operation
- Software programmable for one of 64 different serial clock frequencies
- Software-selectable acknowledge bit
- Interrupt-driven byte-by-byte data transfer
- Arbitration-lost interrupt with automatic mode switching from master to slave
- Calling address identification interrupt
- START and STOP signal generation and detection
- Repeated START signal generation and detection
- Acknowledge bit generation and detection
- Bus busy detection
- General call recognition

- 10-bit address extension
- Support for *System Management Bus (SMBus) Specification, version 2*
- Programmable glitch input filter
- Low power mode wakeup on slave address match
- Range slave address support
- DMA support

46.1.2 Modes of Operation

The I2C module's operation in various low power modes is as follows:

- Run mode: This is the basic mode of operation. To conserve power in this mode, disable the module.
- Wait mode: The module continues to operate when the core is in wait mode and can provide a wakeup interrupt.
- Stop mode: The module is inactive in stop mode for reduced power consumption, except that address matching is enabled in stop mode. The STOP instruction does not affect the I2C module's register states. In any VLLSx mode, the register contents are reset.

46.1.3 Block Diagram

The following figure is a functional block diagram of the I2C module.

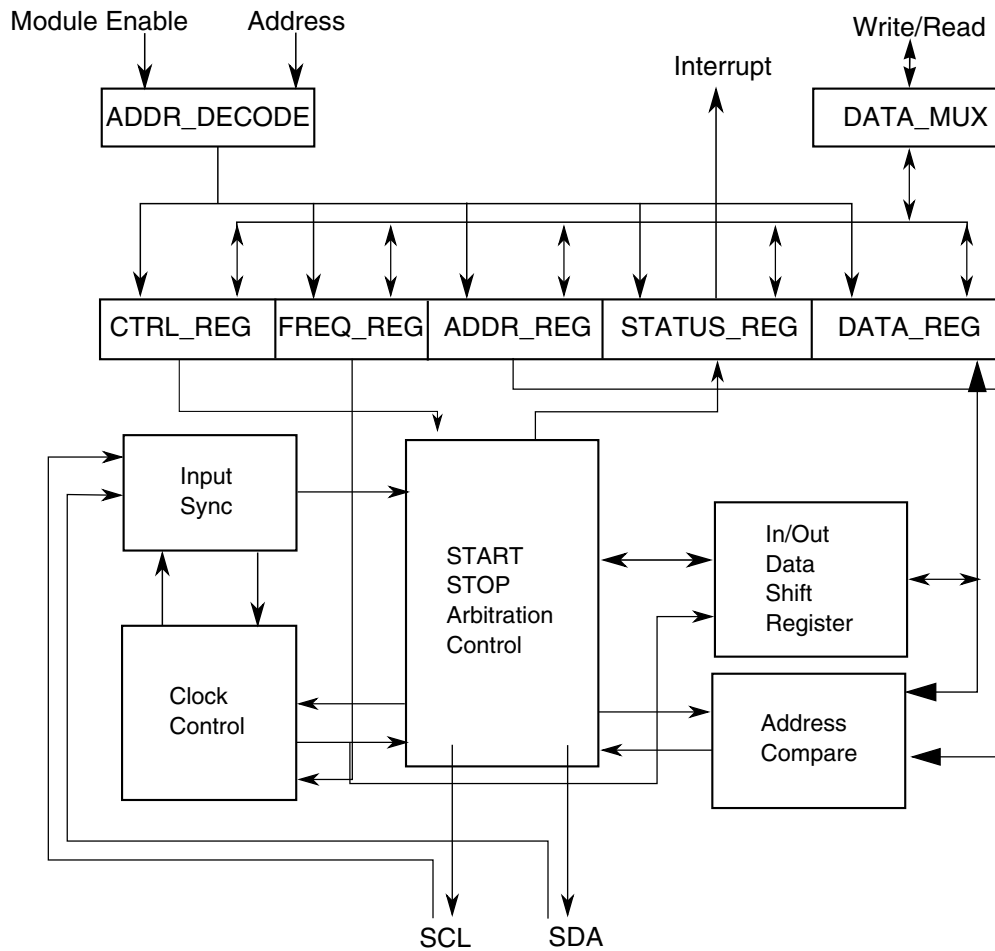

Figure 46-1. I2C Functional Block Diagram

46.2 I²C Signal Descriptions

The signal properties of I²C are shown in the following table.

Table 46-1. I²C Signal Descriptions

Signal	Description	I/O
SCL	Bidirectional serial clock line of the I ² C system.	I/O
SDA	Bidirectional serial data line of the I ² C system.	I/O

46.3 Memory Map and Register Descriptions

This section describes in detail all I2C registers accessible to the end user.

I2C memory map

Absolute address (hex)	Register name	Width (in bits)	Access	Reset value	Section/page
4006_6000	I2C Address Register 1 (I2C0_A1)	8	R/W	00h	46.3.1/1209
4006_6001	I2C Frequency Divider register (I2C0_F)	8	R/W	00h	46.3.2/1209
4006_6002	I2C Control Register 1 (I2C0_C1)	8	R/W	00h	46.3.3/1210
4006_6003	I2C Status Register (I2C0_S)	8	R/W	80h	46.3.4/1212
4006_6004	I2C Data I/O register (I2C0_D)	8	R/W	00h	46.3.5/1214
4006_6005	I2C Control Register 2 (I2C0_C2)	8	R/W	00h	46.3.6/1215
4006_6006	I2C Programmable Input Glitch Filter register (I2C0_FLT)	8	R/W	00h	46.3.7/1216
4006_6007	I2C Range Address register (I2C0_RA)	8	R/W	00h	46.3.8/1216
4006_6008	I2C SMBus Control and Status register (I2C0_SMB)	8	R/W	00h	46.3.9/1217
4006_6009	I2C Address Register 2 (I2C0_A2)	8	R/W	C2h	46.3.10/1218
4006_600A	I2C SCL Low Timeout Register High (I2C0_SLTH)	8	R/W	00h	46.3.11/1219
4006_600B	I2C SCL Low Timeout Register Low (I2C0_SLTL)	8	R/W	00h	46.3.12/1219
4006_7000	I2C Address Register 1 (I2C1_A1)	8	R/W	00h	46.3.1/1209
4006_7001	I2C Frequency Divider register (I2C1_F)	8	R/W	00h	46.3.2/1209
4006_7002	I2C Control Register 1 (I2C1_C1)	8	R/W	00h	46.3.3/1210
4006_7003	I2C Status Register (I2C1_S)	8	R/W	80h	46.3.4/1212
4006_7004	I2C Data I/O register (I2C1_D)	8	R/W	00h	46.3.5/1214
4006_7005	I2C Control Register 2 (I2C1_C2)	8	R/W	00h	46.3.6/1215
4006_7006	I2C Programmable Input Glitch Filter register (I2C1_FLT)	8	R/W	00h	46.3.7/1216
4006_7007	I2C Range Address register (I2C1_RA)	8	R/W	00h	46.3.8/1216

Table continues on the next page...

I2C memory map (continued)

Absolute address (hex)	Register name	Width (in bits)	Access	Reset value	Section/page
4006_7008	I2C SMBus Control and Status register (I2C1_SMB)	8	R/W	00h	46.3.9/1217
4006_7009	I2C Address Register 2 (I2C1_A2)	8	R/W	C2h	46.3.10/1218
4006_700A	I2C SCL Low Timeout Register High (I2C1_SLTH)	8	R/W	00h	46.3.11/1219
4006_700B	I2C SCL Low Timeout Register Low (I2C1_SLTL)	8	R/W	00h	46.3.12/1219

46.3.1 I2C Address Register 1 (I2Cx_A1)

This register contains the slave address to be used by the I2C module.

Addresses: I2C0_A1 is 4006_6000h base + 0h offset = 4006_6000h

I2C1_A1 is 4006_7000h base + 0h offset = 4006_7000h

Bit	7	6	5	4	3	2	1	0
Read	AD[7:1]							0
Write	AD[7:1]							
Reset	0	0	0	0	0	0	0	0

I2Cx_A1 field descriptions

Field	Description
7–1 AD[7:1]	Address Contains the primary slave address used by the I2C module when it is addressed as a slave. This field is used in the 7-bit address scheme and the lower seven bits in the 10-bit address scheme.
0 Reserved	This read-only field is reserved and always has the value zero.

46.3.2 I2C Frequency Divider register (I2Cx_F)

Addresses: I2C0_F is 4006_6000h base + 1h offset = 4006_6001h

I2C1_F is 4006_7000h base + 1h offset = 4006_7001h

Bit	7	6	5	4	3	2	1	0
Read	MULT			ICR				
Write	MULT			ICR				
Reset	0	0	0	0	0	0	0	0

I2Cx_F field descriptions

Field	Description
7–6 MULT	<p>The MULT bits define the multiplier factor mul. This factor is used along with the SCL divider to generate the I2C baud rate.</p> <p>00 mul = 1 01 mul = 2 10 mul = 4 11 Reserved</p>
5–0 ICR	<p>Clock rate</p> <p>Prescales the bus clock for bit rate selection. This field and the MULT field determine the I2C baud rate, the SDA hold time, the SCL start hold time, and the SCL stop hold time. For a list of values corresponding to each ICR setting, see I2C Divider and Hold Values.</p> <p>The SCL divider multiplied by multiplier factor (mul) determines the I2C baud rate.</p> <p>$I2C \text{ baud rate} = \text{bus speed (Hz)} / (\text{mul} \times \text{SCL divider})$</p> <p>The SDA hold time is the delay from the falling edge of SCL (I2C clock) to the changing of SDA (I2C data).</p> <p>$SDA \text{ hold time} = \text{bus period (s)} \times \text{mul} \times \text{SDA hold value}$</p> <p>The SCL start hold time is the delay from the falling edge of SDA (I2C data) while SCL is high (start condition) to the falling edge of SCL (I2C clock).</p> <p>$SCL \text{ start hold time} = \text{bus period (s)} \times \text{mul} \times \text{SCL start hold value}$</p> <p>The SCL stop hold time is the delay from the rising edge of SCL (I2C clock) to the rising edge of SDA (I2C data) while SCL is high (stop condition).</p> <p>$SCL \text{ stop hold time} = \text{bus period (s)} \times \text{mul} \times \text{SCL stop hold value}$</p>

46.3.3 I2C Control Register 1 (I2Cx_C1)

Addresses: I2C0_C1 is 4006_6000h base + 2h offset = 4006_6002h

I2C1_C1 is 4006_7000h base + 2h offset = 4006_7002h

Bit	7	6	5	4	3	2	1	0
Read	IICEN	IICIE	MST	TX	TXAK	0	WUEN	DMAEN
Write						RSTA		
Reset	0	0	0	0	0	0	0	0

I2Cx_C1 field descriptions

Field	Description
7 IICEN	<p>I2C enable</p> <p>Enables I2C module operation.</p>

Table continues on the next page...

I2Cx_C1 field descriptions (continued)

Field	Description
	0 Disabled 1 Enabled
6 IICIE	I2C interrupt enable Enables I2C interrupt requests. 0 Disabled 1 Enabled
5 MST	Master mode select When the MST bit is changed from a 0 to a 1, a START signal is generated on the bus and master mode is selected. When this bit changes from a 1 to a 0, a STOP signal is generated and the mode of operation changes from master to slave. 0 Slave mode 1 Master mode
4 TX	Transmit mode select Selects the direction of master and slave transfers. In master mode this bit must be set according to the type of transfer required. Therefore, for address cycles, this bit is always set. When addressed as a slave this bit must be set by software according to the SRW bit in the status register. 0 Receive 1 Transmit
3 TXAK	Transmit acknowledge enable Specifies the value driven onto the SDA during data acknowledge cycles for both master and slave receivers. The value of the FACK bit affects NACK/ACK generation. 0 An acknowledge signal is sent to the bus on the following (if FACK is cleared) or current (if FACK is set) receiving byte. 1 No acknowledge signal is sent to the bus on the following (if FACK is cleared) or current (if FACK is set) receiving data byte. NOTE: SCL is held low until TXAK is written.
2 RSTA	Repeat START Writing a one to this bit generates a repeated START condition provided it is the current master. This bit will always be read as zero. Attempting a repeat at the wrong time results in loss of arbitration.
1 WUEN	Wakeup enable The I2C module can wake the MCU from low power mode with no peripheral bus running when slave address matching occurs. 0 Normal operation. No interrupt generated when address matching in low power mode. 1 Enables the wakeup function in low power mode.
0 DMAEN	DMA enable The DMAEN bit enables or disables the DMA function.

Table continues on the next page...

I2Cx_C1 field descriptions (continued)

Field	Description
0	All DMA signalling disabled.
1	<p>DMA transfer is enabled and the following conditions trigger the DMA request:</p> <ul style="list-style-type: none"> • While FACK = 0, a data byte is received, either address or data is transmitted. (ACK/NACK automatic) • While FACK = 0, the first byte received matches the A1 register or is general call address. <p>If any address matching occurs, IAAS and TCF are set. If the direction of transfer is known from master to slave, then it is not required to check the SRW. With this assumption, DMA can also be used in this case. In other cases, if the master reads data from the slave, then it is required to rewrite the C1 register operation. With this assumption, DMA cannot be used.</p> <p>When FACK = 1, an address or a data byte is transmitted.</p>

46.3.4 I2C Status Register (I2Cx_S)

Addresses: I2C0_S is 4006_6000h base + 3h offset = 4006_6003h

I2C1_S is 4006_7000h base + 3h offset = 4006_7003h

Bit	7	6	5	4	3	2	1	0
Read	TCF	IAAS	BUSY	ARBL	RAM	SRW	IICIF	RXAK
Write				w1c				w1c
Reset	1	0	0	0	0	0	0	0

I2Cx_S field descriptions

Field	Description
7 TCF	<p>Transfer complete flag</p> <p>This bit sets on the completion of a byte and acknowledge bit transfer. This bit is valid only during or immediately following a transfer to or from the I2C module. The TCF bit is cleared by reading the I2C data register in receive mode or by writing to the I2C data register in transmit mode.</p> <p>0 Transfer in progress 1 Transfer complete</p>
6 IAAS	<p>Addressed as a slave</p> <p>This bit is set by one of the following conditions:</p> <ul style="list-style-type: none"> • The calling address matches the programmed slave primary address in the A1 register or range address in the RA register (which must be set to a nonzero value). • GCAEN is set and a general call is received. • SIICAEN is set and the calling address matches the second programmed slave address. • ALERTEN is set and an SMBus alert response address is received • RMEN is set and an address is received that is within the range between the values of the A1 and RA registers. <p>This bit sets before the ACK bit. The CPU must check the SRW bit and set TX/RX accordingly. Writing the C1 register with any value clears this bit.</p>

Table continues on the next page...

I2Cx_S field descriptions (continued)

Field	Description
	0 Not addressed 1 Addressed as a slave
5 BUSY	Bus busy Indicates the status of the bus regardless of slave or master mode. This bit is set when a START signal is detected and cleared when a STOP signal is detected. 0 Bus is idle 1 Bus is busy
4 ARBL	Arbitration lost This bit is set by hardware when the arbitration procedure is lost. The ARBL bit must be cleared by software, by writing a one to it. 0 Standard bus operation. 1 Loss of arbitration.
3 RAM	Range address match This bit is set by any of the following conditions: <ul style="list-style-type: none"> Any nonzero calling address is received that matches the address in the RA register. The RMEN bit is set and the calling address is within the range of values of the A1 and RA registers. Writing the C1 register with any value clears this bit. 0 Not addressed 1 Addressed as a slave
2 SRW	Slave read/write When addressed as a slave, SRW indicates the value of the R/ \bar{W} command bit of the calling address sent to the master. 0 Slave receive, master writing to slave 1 Slave transmit, master reading from slave
1 IICIF	Interrupt flag This bit sets when an interrupt is pending. This bit must be cleared by software or by writing a 1 to it in the interrupt routine. One of the following events can set this bit: <ul style="list-style-type: none"> One byte transfer including ACK/NACK bit completes if FACK = 0 One byte transfer excluding ACK/NACK bit completes if FACK = 1. An ACK or NACK is sent on the bus by writing 0 or 1 to TXAK after this bit is set in receive mode Match of slave address to calling address including primary slave address, range slave address, alert response address, second slave address, or general call address. Arbitration lost In SMBus mode, any timeouts except SCL and SDA high timeouts 0 No interrupt pending 1 Interrupt pending
0 RXAK	Receive acknowledge

Table continues on the next page...

I2Cx_S field descriptions (continued)

Field	Description
0	Acknowledge signal was received after the completion of one byte of data transmission on the bus
1	No acknowledge signal detected

46.3.5 I2C Data I/O register (I2Cx_D)

Addresses: I2C0_D is 4006_6000h base + 4h offset = 4006_6004h

I2C1_D is 4006_7000h base + 4h offset = 4006_7004h

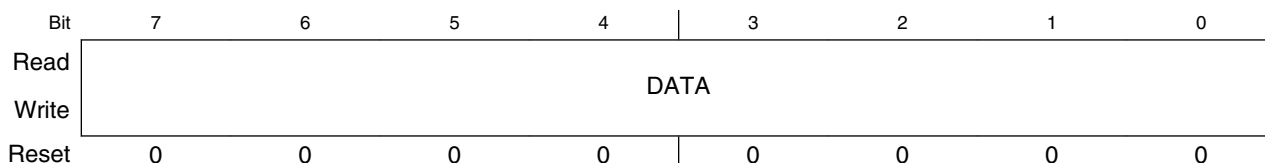

I2Cx_D field descriptions

Field	Description
7-0 DATA	<p>Data</p> <p>In master transmit mode, when data is written to this register, a data transfer is initiated. The most significant bit is sent first. In master receive mode, reading this register initiates receiving of the next byte of data.</p> <p>NOTE: When making the transition out of master receive mode, switch the I2C mode before reading the Data register to prevent an inadvertent initiation of a master receive data transfer.</p> <p>In slave mode, the same functions are available after an address match occurs.</p> <p>The C1[TX] bit must correctly reflect the desired direction of transfer in master and slave modes for the transmission to begin. For example, if the I2C module is configured for master transmit but a master receive is desired, reading the Data register does not initiate the receive.</p> <p>Reading the Data register returns the last byte received while the I2C module is configured in master receive or slave receive mode. The Data register does not reflect every byte that is transmitted on the I2C bus, and neither can software verify that a byte has been written to the Data register correctly by reading it back.</p> <p>In master transmit mode, the first byte of data written to the Data register following assertion of MST (start bit) or assertion of RSTA (repeated start bit) is used for the address transfer and must consist of the calling address (in bits 7-1) concatenated with the required R/W bit (in position bit 0).</p>

46.3.6 I2C Control Register 2 (I2Cx_C2)

Addresses: I2C0_C2 is 4006_6000h base + 5h offset = 4006_6005h

I2C1_C2 is 4006_7000h base + 5h offset = 4006_7005h

Bit	7	6	5	4	3	2	1	0
Read	GCAEN	ADEXT	HDRS	SBRC	RMEN	AD[10:8]		
Write								
Reset	0	0	0	0	0	0	0	0

I2Cx_C2 field descriptions

Field	Description
7 GCAEN	General call address enable Enables general call address. 0 Disabled 1 Enabled
6 ADEXT	Address extension Controls the number of bits used for the slave address. 0 7-bit address scheme 1 10-bit address scheme
5 HDRS	High drive select Controls the drive capability of the I2C pads. 0 Normal drive mode 1 High drive mode
4 SBRC	Slave baud rate control Enables independent slave mode baud rate at max frequency. This forces clock stretching on SCL in very fast I2C modes. 0 The slave baud rate follows the master baud rate and clock stretching may occur 1 Slave baud rate is independent of the master baud rate
3 RMEN	Range address matching enable This bit controls slave address matching for addresses between the values of the A1 and RA registers. When this bit is set, a slave address match occurs for any address greater than the value of the A1 register and less than or equal to the value of the RA register. 0 Range mode disabled. No address match occurs for an address within the range of values of the A1 and RA registers. 1 Range mode enabled. Address matching occurs when a slave receives an address within the range of values of the A1 and RA registers.
2-0 AD[10:8]	Slave address Contains the upper three bits of the slave address in the 10-bit address scheme. This field is valid only when the ADEXT bit is set.

46.3.7 I2C Programmable Input Glitch Filter register (I2Cx_FLT)

Addresses: I2C0_FLT is 4006_6000h base + 6h offset = 4006_6006h

I2C1_FLT is 4006_7000h base + 6h offset = 4006_7006h

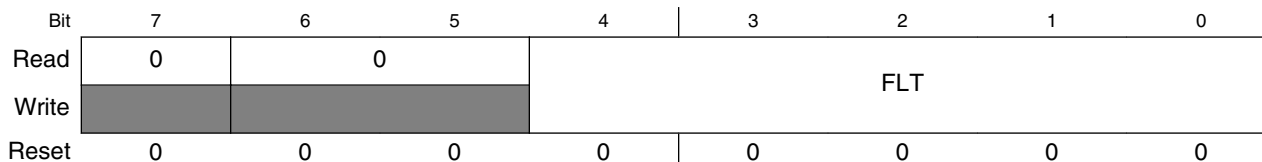

I2Cx_FLT field descriptions

Field	Description
7 Reserved	This read-only field is reserved and always has the value zero.
6-5 Reserved	This read-only field is reserved and always has the value zero.
4-0 FLT	I2C programmable filter factor Controls the width of the glitch, in terms of bus clock cycles, that the filter must absorb. For any glitch whose size is less than or equal to this width setting, the filter does not allow the glitch to pass. 00h No filter/bypass 01-1Fh Filter glitches up to width of <i>n</i> bus clock cycles, where <i>n</i> =1-31d

46.3.8 I2C Range Address register (I2Cx_RA)

Addresses: I2C0_RA is 4006_6000h base + 7h offset = 4006_6007h

I2C1_RA is 4006_7000h base + 7h offset = 4006_7007h

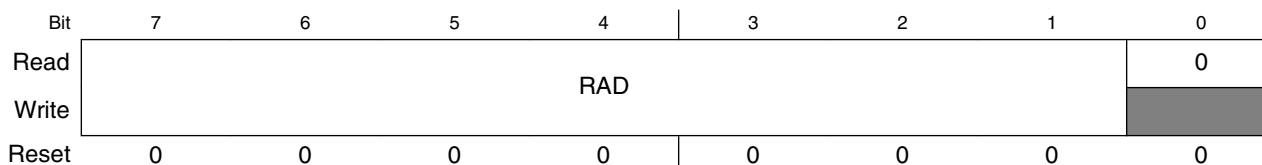

I2Cx_RA field descriptions

Field	Description
7-1 RAD	Range slave address This field contains the slave address to be used by the I2C module. The field is used in the 7-bit address scheme. Any nonzero write enables this register. This register's use is similar to that of the A1 register, but in addition this register can be considered a maximum boundary in range matching mode.
0 Reserved	This read-only field is reserved and always has the value zero.

46.3.9 I2C SMBus Control and Status register (I2Cx_SMB)

NOTE

When the SCL and SDA signals are held high for a length of time greater than the high timeout period, the SHTF1 flag sets. Before reaching this threshold, while the system is detecting how long these signals are being held high, a master assumes that the bus is free. However, the SHTF1 bit rises in the bus transmission process with the idle bus state.

NOTE

When the TCKSEL bit is set, there is no meaning to monitor the SHTF1 bit because the bus speed is too high to match the protocol of SMBus.

Addresses: I2C0_SMB is 4006_6000h base + 8h offset = 4006_6008h

I2C1_SMB is 4006_7000h base + 8h offset = 4006_7008h

Bit	7	6	5	4	3	2	1	0
Read	FAACK	ALERTEN	SIICAEN	TCKSEL	SLTF	SHTF1	SHTF2	SHTF2IE
Write					w1c		w1c	
Reset	0	0	0	0	0	0	0	0

I2Cx_SMB field descriptions

Field	Description
7 FAACK	<p>Fast NACK/ACK enable</p> <p>For SMBus packet error checking, the CPU must be able to issue an ACK or NACK according to the result of receiving data byte.</p> <p>0 An ACK or NACK is sent on the following receiving data byte 1 Writing 0 to TXAK after receiving a data byte generates an ACK. Writing 1 to TXAK after receiving a data byte generates a NACK.</p>
6 ALERTEN	<p>SMBus alert response address enable</p> <p>Enables or disables SMBus alert response address matching.</p> <p>NOTE: After the host responds to a device that used the alert response address, you must use software to put the device's address on the bus. The alert protocol is described in the SMBus specification.</p> <p>0 SMBus alert response address matching is disabled 1 SMBus alert response address matching is enabled</p>
5 SIICAEN	<p>Second I2C address enable</p> <p>Enables or disables SMBus device default address.</p>

Table continues on the next page...

I2Cx_SMB field descriptions (continued)

Field	Description
	0 I2C address register 2 matching is disabled 1 I2C address register 2 matching is enabled
4 TCKSEL	Timeout counter clock select Selects the clock source of the timeout counter. 0 Timeout counter counts at the frequency of the bus clock / 64 1 Timeout counter counts at the frequency of the bus clock
3 SLTF	SCL low timeout flag This bit is set when the SLT register (consisting of the SLTH and SLTL registers) is loaded with a non-zero value (LoValue) and an SCL low timeout occurs. Software clears this bit by writing a logic 1 to it. NOTE: The low timeout function is disabled when the SLT register's value is zero. 0 No low timeout occurs 1 Low timeout occurs
2 SHTF1	SCL high timeout flag 1 This read-only bit sets when SCL and SDA are held high more than clock x LoValue / 512, which indicates the bus is free. This bit is cleared automatically. 0 No SCL high and SDA high timeout occurs 1 SCL high and SDA high timeout occurs
1 SHTF2	SCL high timeout flag 2 This bit sets when SCL is held high and SDA is held low more than clock x LoValue/512. Software clears this bit by writing a 1 to it. 0 No SCL high and SDA low timeout occurs 1 SCL high and SDA low timeout occurs
0 SHTF2IE	SHTF2 interrupt enable Enables SCL high and SDA low timeout interrupt. 0 SHTF2 interrupt is disabled 1 SHTF2 interrupt is enabled

46.3.10 I2C Address Register 2 (I2Cx_A2)

Addresses: I2C0_A2 is 4006_6000h base + 9h offset = 4006_6009h

I2C1_A2 is 4006_7000h base + 9h offset = 4006_7009h

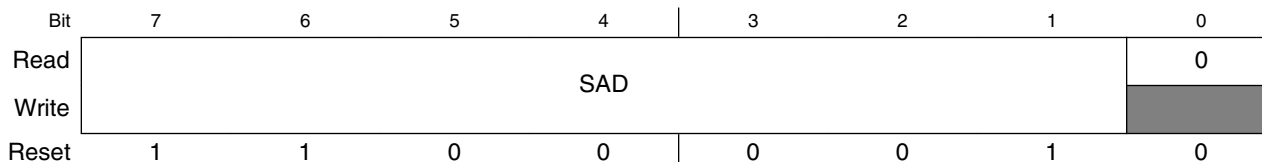

I2Cx_A2 field descriptions

Field	Description
7–1 SAD	SMBus address Contains the slave address used by the SMBus. This field is used on the device default address or other related addresses.
0 Reserved	This read-only field is reserved and always has the value zero.

46.3.11 I2C SCL Low Timeout Register High (I2Cx_SLTH)

Addresses: I2C0_SLTH is 4006_6000h base + Ah offset = 4006_600Ah

I2C1_SLTH is 4006_7000h base + Ah offset = 4006_700Ah

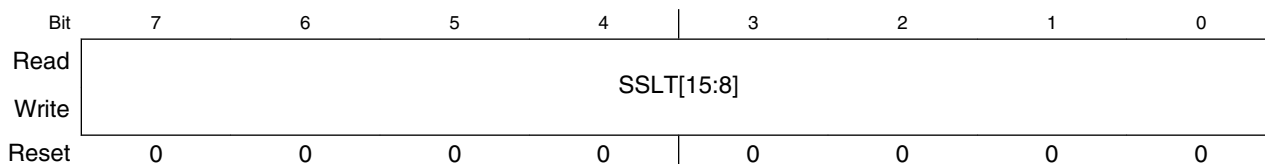

I2Cx_SLTH field descriptions

Field	Description
7–0 SSLT[15:8]	Most significant byte of SCL low timeout value that determines the timeout period of SCL low.

46.3.12 I2C SCL Low Timeout Register Low (I2Cx_SLTL)

Addresses: I2C0_SLTL is 4006_6000h base + Bh offset = 4006_600Bh

I2C1_SLTL is 4006_7000h base + Bh offset = 4006_700Bh

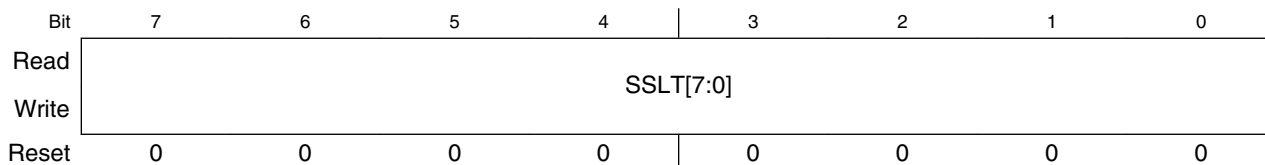

I2Cx_SLTL field descriptions

Field	Description
7–0 SSLT[7:0]	Least significant byte of SCL low timeout value that determines the timeout period of SCL low.

46.4 Functional Description

This section provides a comprehensive functional description of the I2C module.

46.4.1 I2C Protocol

The I2C bus system uses a serial data line (SDA) and a serial clock line (SCL) for data transfers. All devices connected to it must have open drain or open collector outputs. A logic AND function is exercised on both lines with external pull-up resistors. The value of these resistors depends on the system.

Normally, a standard instance of communication is composed of four parts:

1. START signal
2. Slave address transmission
3. Data transfer
4. STOP signal

The STOP signal should not be confused with the CPU STOP instruction. The following figure illustrates I2C bus system communication.

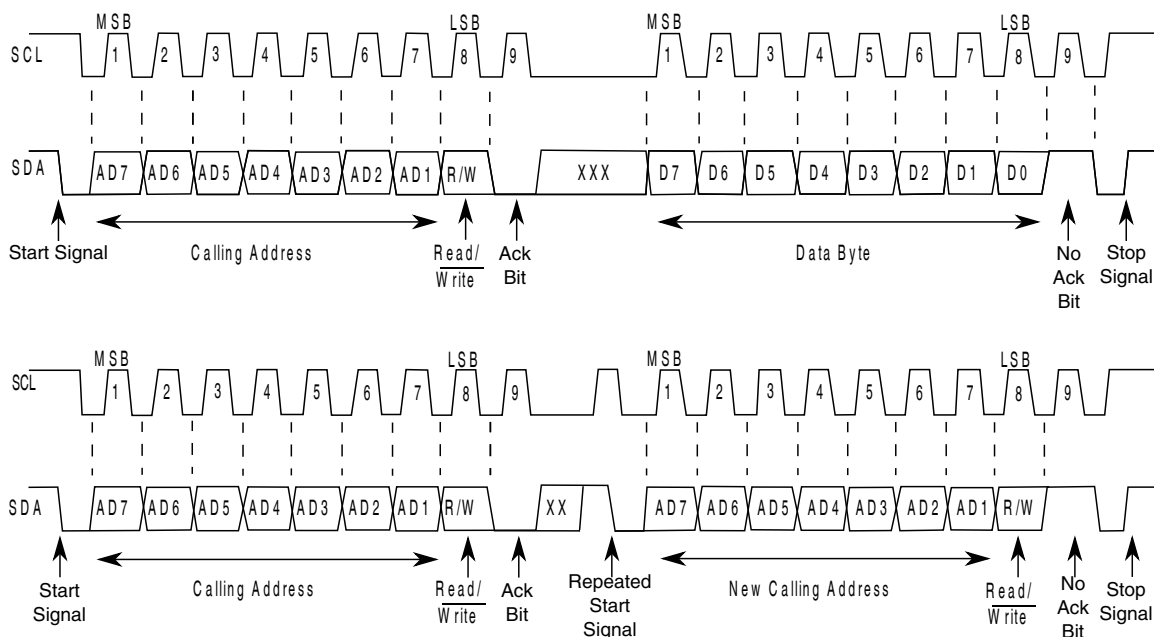

Figure 46-38. I2C Bus Transmission Signals

46.4.1.1 START Signal

The bus is free when no master device is engaging the bus (both SCL and SDA are high). When the bus is free, a master may initiate communication by sending a START signal. A START signal is defined as a high-to-low transition of SDA while SCL is high. This signal denotes the beginning of a new data transfer (each data transfer might contain several bytes of data) and brings all slaves out of their idle states.

46.4.1.2 Slave Address Transmission

Immediately after the START signal, the first byte of a data transfer is the slave address transmitted by the master. This address is a 7-bit calling address followed by an R/\overline{W} bit. The R/\overline{W} bit tells the slave the desired direction of data transfer.

- 1 = Read transfer: The slave transmits data to the master
- 0 = Write transfer: The master transmits data to the slave

Only the slave with a calling address that matches the one transmitted by the master responds by sending an acknowledge bit. The slave sends the acknowledge bit by pulling SDA low at the ninth clock.

No two slaves in the system can have the same address. If the I2C module is the master, it must not transmit an address that is equal to its own slave address. The I2C module cannot be master and slave at the same time. However, if arbitration is lost during an address cycle, the I2C module reverts to slave mode and operates correctly even if it is being addressed by another master.

46.4.1.3 Data Transfers

When successful slave addressing is achieved, data transfer can proceed on a byte-by-byte basis in the direction specified by the R/\overline{W} bit sent by the calling master.

All transfers that follow an address cycle are referred to as data transfers, even if they carry subaddress information for the slave device.

Each data byte is 8 bits long. Data may be changed only while SCL is low. Data must be held stable while SCL is high. There is one clock pulse on SCL for each data bit, and the MSB is transferred first. Each data byte is followed by a ninth (acknowledge) bit, which is signaled from the receiving device by pulling SDA low at the ninth clock. In summary, one complete data transfer needs nine clock pulses.

If the slave receiver does not acknowledge the master in the ninth bit, the slave must leave SDA high. The master interprets the failed acknowledgement as an unsuccessful data transfer.

If the master receiver does not acknowledge the slave transmitter after a data byte transmission, the slave interprets it as an end to data transfer and releases the SDA line.

In the case of a failed acknowledgement by either the slave or master, the data transfer is aborted and the master does one of two things:

- Relinquishes the bus by generating a STOP signal.
- Commences a new call by generating a repeated START signal.

46.4.1.4 STOP Signal

The master can terminate the communication by generating a STOP signal to free the bus. A STOP signal is defined as a low-to-high transition of SDA while SCL is asserted.

The master can generate a STOP signal even if the slave has generated an acknowledgement, at which point the slave must release the bus.

46.4.1.5 Repeated START Signal

The master may generate a START signal followed by a calling command without generating a STOP signal first. This action is called a repeated START. The master uses a repeated START to communicate with another slave or with the same slave in a different mode (transmit/receive mode) without releasing the bus.

46.4.1.6 Arbitration Procedure

The I2C bus is a true multimaster bus that allows more than one master to be connected on it.

If two or more masters try to control the bus at the same time, a clock synchronization procedure determines the bus clock. The bus clock's low period is equal to the longest clock low period, and the high period is equal to the shortest one among the masters.

The relative priority of the contending masters is determined by a data arbitration procedure. A bus master loses arbitration if it transmits logic level 1 while another master transmits logic level 0. The losing masters immediately switch to slave receive mode and

stop driving SDA output. In this case, the transition from master to slave mode does not generate a STOP condition. Meanwhile, hardware sets a status bit to indicate the loss of arbitration.

46.4.1.7 Clock Synchronization

Because wire AND logic is performed on SCL, a high-to-low transition on SCL affects all devices connected on the bus. The devices start counting their low period and, after a device's clock has gone low, that device holds SCL low until the clock reaches its high state. However, the change of low to high in this device clock might not change the state of SCL if another device clock is still within its low period. Therefore, the synchronized clock SCL is held low by the device with the longest low period. Devices with shorter low periods enter a high wait state during this time (see the following diagram). When all applicable devices have counted off their low period, the synchronized clock SCL is released and pulled high. Afterward there is no difference between the device clocks and the state of SCL, and all devices start counting their high periods. The first device to complete its high period pulls SCL low again.

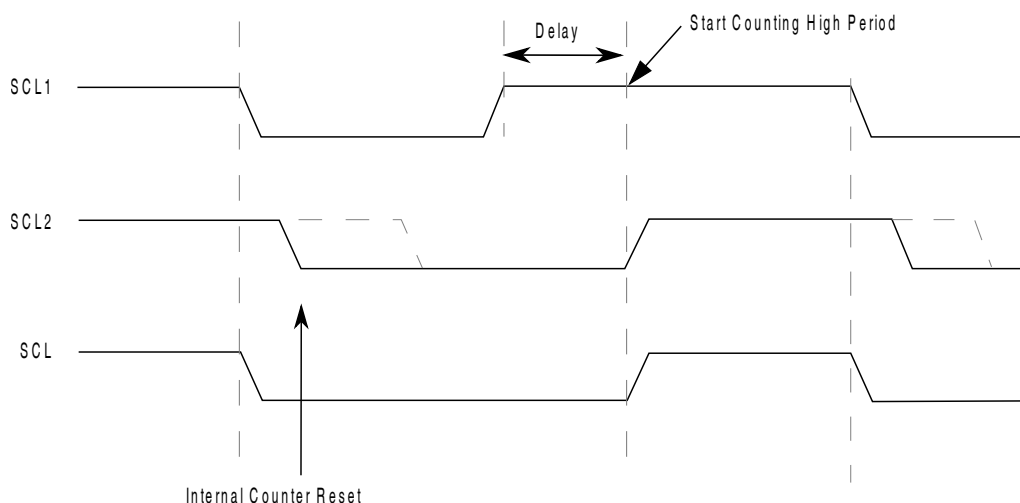

Figure 46-39. I2C Clock Synchronization

46.4.1.8 Handshaking

The clock synchronization mechanism can be used as a handshake in data transfers. A slave device may hold SCL low after completing a single byte transfer (9 bits). In this case, it halts the bus clock and forces the master clock into wait states until the slave releases SCL.

46.4.1.9 Clock Stretching

The clock synchronization mechanism can be used by slaves to slow down the bit rate of a transfer. After the master drives SCL low, a slave can drive SCL low for the required period and then release it. If the slave's SCL low period is greater than the master's SCL low period, the resulting SCL bus signal's low period is stretched.

46.4.1.10 I2C Divider and Hold Values

Table 46-41. I2C Divider and Hold Values

ICR (hex)	SCL Divider	SDA Hold Value	SCL Hold (Start) Value	SCL Hold (Stop) Value	ICR (hex)	SCL Divider (clocks)	SDA Hold (clocks)	SCL Hold (Start) Value	SCL Hold (Stop) Value
00	20	7	6	11	20	160	17	78	81
01	22	7	7	12	21	192	17	94	97
02	24	8	8	13	22	224	33	110	113
03	26	8	9	14	23	256	33	126	129
04	28	9	10	15	24	288	49	142	145
05	30	9	11	16	25	320	49	158	161
06	34	10	13	18	26	384	65	190	193
07	40	10	16	21	27	480	65	238	241
08	28	7	10	15	28	320	33	158	161
09	32	7	12	17	29	384	33	190	193
0A	36	9	14	19	2A	448	65	222	225
0B	40	9	16	21	2B	512	65	254	257
0C	44	11	18	23	2C	576	97	286	289
0D	48	11	20	25	2D	640	97	318	321
0E	56	13	24	29	2E	768	129	382	385
0F	68	13	30	35	2F	960	129	478	481
10	48	9	18	25	30	640	65	318	321
11	56	9	22	29	31	768	65	382	385
12	64	13	26	33	32	896	129	446	449
13	72	13	30	37	33	1024	129	510	513
14	80	17	34	41	34	1152	193	574	577
15	88	17	38	45	35	1280	193	638	641
16	104	21	46	53	36	1536	257	766	769
17	128	21	58	65	37	1920	257	958	961
18	80	9	38	41	38	1280	129	638	641

Table continues on the next page...

Table 46-41. I2C Divider and Hold Values (continued)

ICR (hex)	SCL Divider	SDA Hold Value	SCL Hold (Start) Value	SCL Hold (Stop) Value	ICR (hex)	SCL Divider (clocks)	SDA Hold (clocks)	SCL Hold (Start) Value	SCL Hold (Stop) Value
19	96	9	46	49	39	1536	129	766	769
1A	112	17	54	57	3A	1792	257	894	897
1B	128	17	62	65	3B	2048	257	1022	1025
1C	144	25	70	73	3C	2304	385	1150	1153
1D	160	25	78	81	3D	2560	385	1278	1281
1E	192	33	94	97	3E	3072	513	1534	1537
1F	240	33	118	121	3F	3840	513	1918	1921

46.4.2 10-bit Address

For 10-bit addressing, 0x11110 is used for the first 5 bits of the first address byte. Various combinations of read/write formats are possible within a transfer that includes 10-bit addressing.

46.4.2.1 Master-Transmitter Addresses a Slave-Receiver

The transfer direction is not changed. When a 10-bit address follows a START condition, each slave compares the first seven bits of the first byte of the slave address (11110XX) with its own address and tests whether the eighth bit (R/\overline{W} direction bit) is 0. It is possible that more than one device finds a match and generates an acknowledge (A1). Each slave that finds a match compares the eight bits of the second byte of the slave address with its own address, but only one slave finds a match and generate an acknowledge (A2). The matching slave remains addressed by the master until it receives a STOP condition (P) or a repeated START condition (Sr) followed by a different slave address.

Table 46-42. Master-Transmitter Addresses Slave-Receiver with a 10-bit Address

S	Slave address first 7 bits 11110 + AD10 + AD9	R/W 0	A1	Slave address second byte AD[8:1]	A2	Data	A	...	Data	A/A	P

After the master-transmitter has sent the first byte of the 10-bit address, the slave-receiver sees an I2C interrupt. User software must ensure that for this interrupt, the contents of the Data register are ignored and not treated as valid data.

46.4.2.2 Master-Receiver Addresses a Slave-Transmitter

The transfer direction is changed after the second R/\overline{W} bit. Up to and including acknowledge bit A2, the procedure is the same as that described for a master-transmitter addressing a slave-receiver. After the repeated START condition (Sr), a matching slave remembers that it was addressed before. This slave then checks whether the first seven bits of the first byte of the slave address following Sr are the same as they were after the START condition (S), and it tests whether the eighth (R/\overline{W}) bit is 1. If there is a match, the slave considers that it has been addressed as a transmitter and generates acknowledge A3. The slave-transmitter remains addressed until it receives a STOP condition (P) or a repeated START condition (Sr) followed by a different slave address.

After a repeated START condition (Sr), all other slave devices also compare the first seven bits of the first byte of the slave address with their own addresses and test the eighth (R/\overline{W}) bit. However, none of them are addressed because $R/\overline{W} = 1$ (for 10-bit devices), or the 11110XX slave address (for 7-bit devices) does not match.

Table 46-43. Master-Receiver Addresses a Slave-Transmitter with a 10-bit Address

S	Slave address first 7 bits 11110 + AD10 + AD9	R/W 0	A1	Slave address second byte AD[8:1]	A2	Sr	Slave address first 7 bits 11110 + AD10 + AD9	R/W 1	A3	Data	A	...	Data	A	P
---	--	----------	----	--------------------------------------	----	----	--	----------	----	------	---	-----	------	---	---

After the master-receiver has sent the first byte of the 10-bit address, the slave-transmitter sees an I2C interrupt. User software must ensure that for this interrupt, the contents of the Data register are ignored and not treated as valid data.

46.4.3 Address Matching

All received addresses can be requested in 7-bit or 10-bit address format. The Address Register 1, which contains the I2C primary slave address, always participates in the address matching process. If the GCAEN bit is set, general call participates the address matching process. If the ALERTEN bit is set, alert response participates the address matching process. If the SIICAEN bit is set, the Address Register 2 participates in the

address matching process. If the Range Address register is programmed to a nonzero value, the range address itself participates in the address matching process. If the RMEN bit is set, any address within the range of values of the Address Register 1 and the Range Address register participates in the address matching process. The Range Address register must be programmed to a value greater than the value of the Address Register 1.

When the I2C module responds to one of these addresses, it acts as a slave-receiver and the IAAS bit is set after the address cycle. Software must read the Data register after the first byte transfer to determine that the address is matched.

46.4.4 System Management Bus Specification

SMBus provides a control bus for system and power management related tasks. A system can use SMBus to pass messages to and from devices instead of tripping individual control lines. Removing the individual control lines reduces pin count. Accepting messages ensures future expandability. With the system management bus, a device can provide manufacturer information, tell the system what its model/part number is, save its state for a suspend event, report different types of errors, accept control parameters, and return its status.

46.4.4.1 Timeouts

The $T_{\text{TIMEOUT,MIN}}$ parameter allows a master or slave to conclude that a defective device is holding the clock low indefinitely or a master is intentionally trying to drive devices off the bus. It is highly recommended that a slave device release the bus (stop driving the bus and let SCL and SDA float high) when it detects any single clock held low longer than $T_{\text{TIMEOUT,MIN}}$. Devices that have detected this condition must reset their communication and be able to receive a new START condition within the timeframe of $T_{\text{TIMEOUT,MAX}}$.

SMBus defines a clock low timeout, T_{TIMEOUT} , of 35 ms, specifies $T_{\text{LOW:SEXT}}$ as the cumulative clock low extend time for a slave device, and specifies $T_{\text{LOW:MEXT}}$ as the cumulative clock low extend time for a master device.

46.4.4.1.1 SCL Low Timeout

If the SCL line is held low by a slave device on the bus, no further communication is possible. Furthermore, the master cannot force the SCL line high to correct the error condition. To solve this problem, the SMBus protocol specifies that devices participating in a transfer must detect any clock cycle held low longer than a timeout value condition. Devices that have detected the timeout condition must reset the communication. When

the I2C module is an active master, if it detects that SMBCLK low has exceeded the value of $T_{\text{TIMEOUT,MIN}}$, it must generate a stop condition within or after the current data byte in the transfer process. When the I2C module is a slave, if it detects the $T_{\text{TIMEOUT,MIN}}$ condition, it resets its communication and is then able to receive a new START condition.

46.4.4.1.2 SCL High Timeout

When the I2C module has determined that the SMBCLK and SMBDAT signals have been high for at least $T_{\text{HIGH:MAX}}$, it assumes that the bus is idle. A HIGH timeout can occur in two ways:

1. HIGH timeout detected after a STOP condition appears on the bus
2. HIGH timeout detected after a START condition, but before a STOP condition appears on the bus

Any master detecting either scenario can assume the bus is free when SHTF1 rises. A HIGH timeout occurs in scenario 2 if a master ever detects that both the BUSY bit is high and SHTF1 is high.

When the SMBDAT signal is low and the SMBCLK signal is high for a period of time, the other kind of timeout occurs. The time period must be defined in software. SHTF2 is used as the flag when the time limit is reached. This flag is also an interrupt resource, so it also triggers IICIF.

46.4.4.1.3 CSMBCLK TIMEOUT MEXT and CSMBCLK TIMEOUT SEXT

The following figure illustrates the definition of the timeout intervals $T_{\text{LOW:SEXT}}$ and $T_{\text{LOW:MEXT}}$. When in master mode, the I2C module must not cumulatively extend its clock cycles for a period greater than $T_{\text{LOW:MEXT}}$ within a byte, where each byte is defined as START-to-ACK, ACK-to-ACK, or ACK-to-STOP. When CSMBCLK TIMEOUT MEXT occurs, SMBus MEXT rises and also triggers the SLTF.

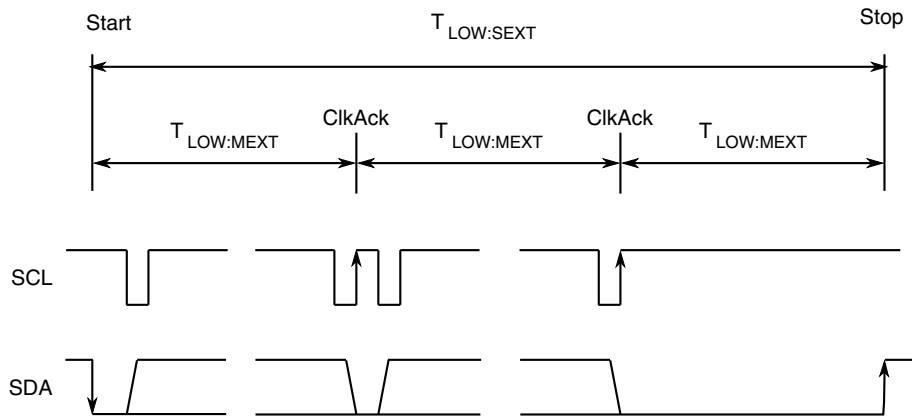

Figure 46-40. Timeout measurement intervals

A master is allowed to abort the transaction in progress to any slave that violates the $T_{LOW:SEXT}$ or $T_{TIMEOUT,MIN}$ specifications. To abort the transaction, the master issues a STOP condition at the conclusion of the byte transfer in progress. When a slave, the I2C module must not cumulatively extend its clock cycles for a period greater than $T_{LOW:SEXT}$ during any message from the initial START to the STOP. When CSMBCLK TIMEOUT SEXT occurs, SEXT rises and also triggers SLTF.

NOTE

CSMBCLK TIMEOUT SEXT and CSMBCLK TIMEOUT MEXT are optional functions that are implemented in the second step.

46.4.4.2 FAST ACK and NACK

To improve reliability and communication robustness, implementation of packet error checking (PEC) by SMBus devices is optional for SMBus devices but required for devices participating in and only during the address resolution protocol (ARP) process. The PEC is a CRC-8 error checking byte, calculated on all the message bytes. The PEC is appended to the message by the device that supplied the last data byte. If the PEC is present but not correct, a NACK is issued by the receiver. Otherwise an ACK is issued. In order to calculate the CRC-8 by software, this module can hold the SCL line low after receiving the eighth SCL (8th bit) if this byte is a data byte. So software can determine whether an ACK or NACK should be sent to the bus by setting or clearing the TXAK bit if the FACK (fast ACK/NACK enable) bit is enabled.

SMBus requires a device always to acknowledge its own address, as a mechanism to detect the presence of a removable device (such as a battery or docking station) on the bus. In addition to indicating a slave device busy condition, SMBus uses the NACK mechanism to indicate the reception of an invalid command or invalid data. Because such a condition may occur on the last byte of the transfer, SMBus devices are required to

have the ability to generate the not acknowledge after the transfer of each byte and before the completion of the transaction. This requirement is important because SMBus does not provide any other resend signaling. This difference in the use of the NACK signaling has implications on the specific implementation of the SMBus port, especially in devices that handle critical system data such as the SMBus host and the SBS components.

NOTE

In the last byte of master receive slave transmit mode, the master must send a NACK to the bus, so FACK must be switched off before the last byte transmits.

46.4.5 Resets

The I2C module is disabled after a reset. The I2C module cannot cause a core reset.

46.4.6 Interrupts

The I2C module generates an interrupt when any of the events in the following table occur, provided that the IICIE bit is set. The interrupt is driven by the IICIF bit (of the I2C Status Register) and masked with the IICIE bit (of the I2C Control Register 1). The IICIF bit must be cleared (by software) by writing 1 to it in the interrupt routine. The SMBus timeouts interrupt is driven by SLTF and masked with the IICIE bit. The SLTF bit must be cleared by software by writing 1 to it in the interrupt routine. You can determine the interrupt type by reading the Status Register.

NOTE

In master receive mode, the FACK bit must be set to zero before the last byte transfer.

Table 46-44. Interrupt Summary

Interrupt Source	Status	Flag	Local Enable
Complete 1-byte transfer	TCF	IICIF	IICIE
Match of received calling address	IAAS	IICIF	IICIE
Arbitration lost	ARBL	IICIF	IICIE
SMBus SCL low timeout interrupt flag	SLTF	IICIF	IICIE
SMBus SCL high SDA low timeout interrupt flag	SHTF2	IICIF	IICIE & SHTF2IE
Wakeup from stop interrupt	IAAS	IICIF	IICIE & WUEN

46.4.6.1 Byte Transfer Interrupt

The transfer complete flag (TCF) bit is set at the falling edge of the ninth clock to indicate the completion of a byte and acknowledgement transfer. When FACK is enabled, TCF is then set at the falling edge of 8th clock to indicate the completion of byte.

46.4.6.2 Address Detect Interrupt

When the calling address matches the programmed slave address (I2C Address Register) or when the GCAEN bit is set and a general call is received, the IAAS bit in the Status Register is set. The CPU is interrupted, provided the IICIE bit is set. The CPU must check the SRW bit and set its Tx mode accordingly.

46.4.6.3 Exit from Low-Power/Stop Modes

The slave receive input detect circuit and address matching feature are still active on low power modes (wait and stop). An asynchronous input matching slave address or general call address brings the CPU out of low power/stop mode if the interrupt is not masked. Therefore, TCF and IAAS both can trigger this interrupt.

46.4.6.4 Arbitration Lost Interrupt

The I2C is a true multimaster bus that allows more than one master to be connected on it. If two or more masters try to control the bus at the same time, the relative priority of the contending masters is determined by a data arbitration procedure. The I2C module asserts the arbitration-lost interrupt when it loses the data arbitration process and the ARBL bit in the Status Register is set.

Arbitration is lost in the following circumstances:

1. SDA is sampled as low when the master drives high during an address or data transmit cycle.
2. SDA is sampled as low when the master drives high during the acknowledge bit of a data receive cycle.
3. A START cycle is attempted when the bus is busy.
4. A repeated START cycle is requested in slave mode.
5. A STOP condition is detected when the master did not request it.

The ARBL bit must be cleared (by software) by writing 1 to it.

46.4.6.5 Timeout Interrupt in SMBus

When the IICIE bit is set, the I2C module asserts a timeout interrupt (outputs SLTF and SHTF2) upon detection of any of the mentioned timeout conditions, with one exception. The SCL high and SDA high TIMEOUT mechanism must not be used to influence the timeout interrupt output, because this timeout indicates an idle condition on the bus. SHTF1 rises when it matches the SCL high and SDA high TIMEOUT and falls automatically just to indicate the bus status. The SHTF2's timeout period is the same as that of SHTF1, which is short compared to that of SLTF, so another control bit, SHTF2IE, is added to enable or disable it.

46.4.7 Programmable Input Glitch Filter

An I2C glitch filter has been added outside legacy I2C modules but within the I2C package. This filter can absorb glitches on the I2C clock and data lines for the I2C module. The width of the glitch to absorb can be specified in terms of the number of (half) bus clock cycles. A single Programmable Input Glitch Filter control register is provided. Effectively, any down-up-down or up-down-up transition on the data line that occurs within the number of clock cycles programmed in this register is ignored by the I2C module. The programmer must specify the size of the glitch (in terms of bus clock cycles) for the filter to absorb and not pass.

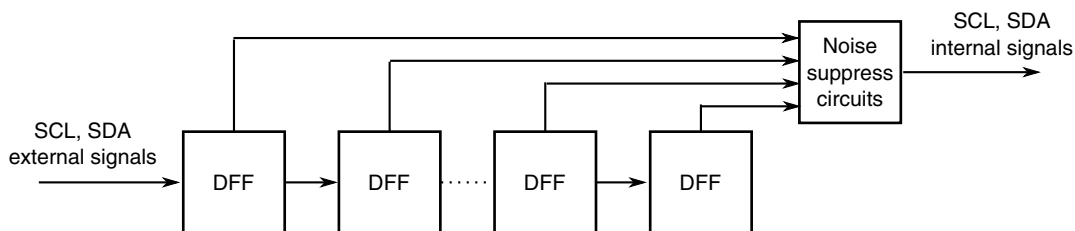

Figure 46-41. Programmable input glitch filter diagram

46.4.8 Address Matching Wakeup

When a primary, range, or general call address match occurs when the I2C module is in slave receive mode, the MCU wakes from low power mode with no peripheral bus running. After the address matching IAAS bit is set, an interrupt is sent at the end of address matching to wake the core. The IAAS bit must be cleared after the clock recovery.

NOTE

After the system recovers and is in run mode, restart the I2C module if necessary. The SCL line is not held low until the I2C module resets after address matching. The main purpose of this feature is to wake the MCU from stop mode. Data sent on the bus that is the same as a target device address might also wake the target MCU.

46.4.9 DMA Support

If the DMAEN bit is cleared and the IICIE bit is set, an interrupt condition generates an interrupt request. If the DMAEN bit is set and the IICIE bit is set, an interrupt condition generates a DMA request instead. DMA requests are generated by the transfer complete flag (TCF).

If the DMAEN bit is set, the only arbitration lost is to another I2C module (error), and SCL low timeouts (error) generate CPU interrupts. All other events initiate a DMA transfer.

NOTE

Before the last byte of master receive mode, TXAK must be set to send a NACK after the last byte's transfer. Therefore, the DMA must be disabled before the last byte's transfer.

NOTE

In 10-bit address mode transmission, the addresses to send occupy 2-3 bytes. During this transfer period, the DMA must be disabled because the C1 register is written to send a repeat start or to change the transfer direction.

46.5 Initialization/Application Information

Module Initialization (Slave)

1. Write: Control Register 2
 - to enable or disable general call
 - to select 10-bit or 7-bit addressing mode
2. Write: Address Register 1 to set the slave address
3. Write: Control Register 1 to enable the I2C module and interrupts
4. Initialize RAM variables (IICEN = 1 and IICIE = 1) for transmit data
5. Initialize RAM variables used to achieve the routine shown in the following figure

Module Initialization (Master)

1. Write: Frequency Divider register to set the I2C baud rate (example provided in this chapter)
2. Write: Control Register 1 to enable the I2C module and interrupts
3. Initialize RAM variables (IICEN = 1 and IICIE = 1) for transmit data
4. Initialize RAM variables used to achieve the routine shown in the following figure
5. Write: Control Register 1 to enable TX
6. Write: Control Register 1 to enable MST (master mode)
7. Write: Data register with the address of the target slave (the LSB of this byte determines whether the communication is master receive or transmit)

The routine shown in the following figure can handle both master and slave I2C operations. For slave operation, an incoming I2C message that contains the proper address begins I2C communication. For master operation, communication must be initiated by writing the Data register.

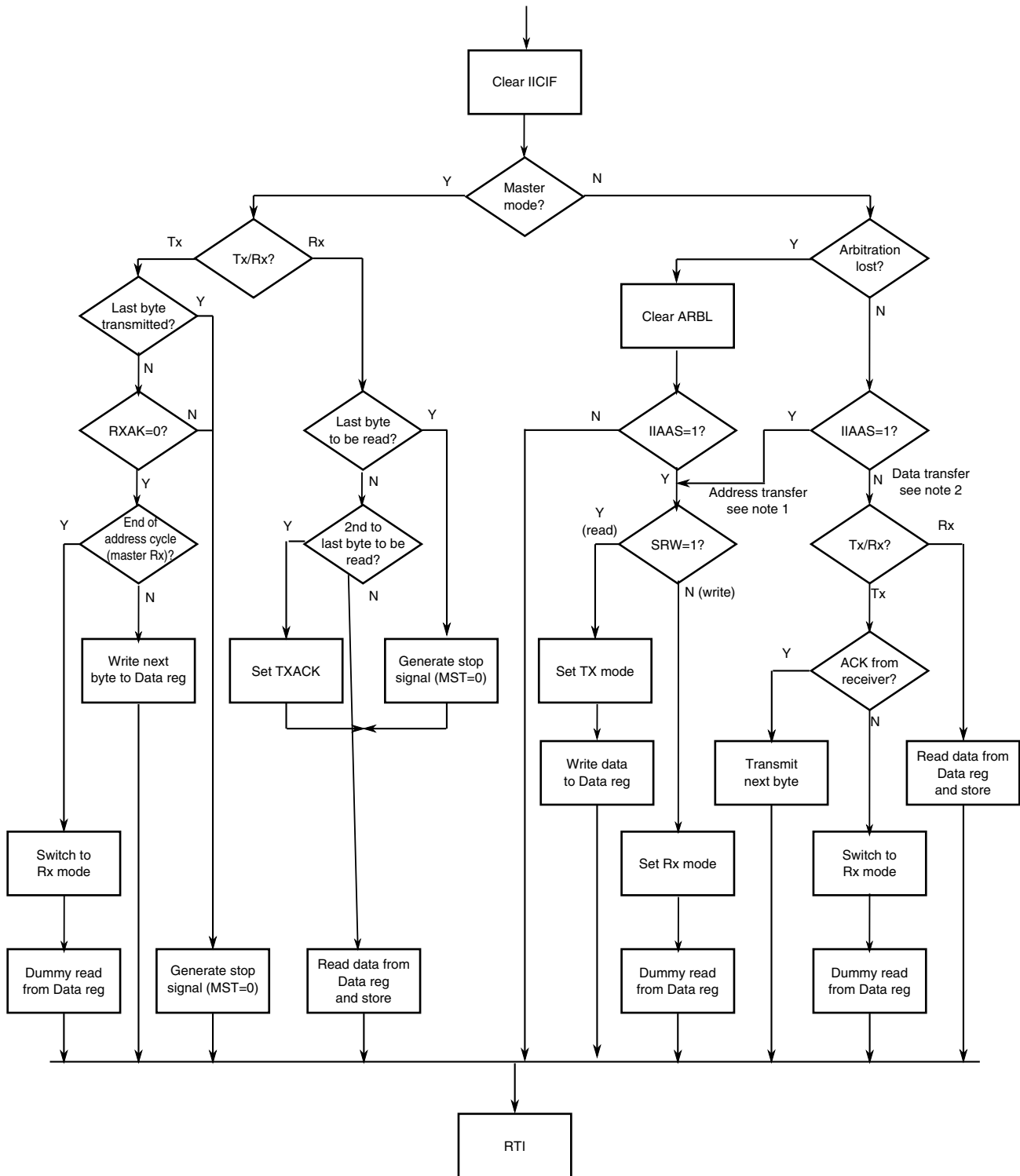

Notes:

1. If general call is enabled, check to determine if the received address is a general call address (0x00). If the received address is a general call address, the general call must be handled by user software.
2. When 10-bit addressing addresses a slave, the slave sees an interrupt following the first byte of the extended address. Ensure that for this interrupt, the contents of the Data register are ignored and not treated as a valid data transfer.

Figure 46-42. Typical I2C Interrupt Routine

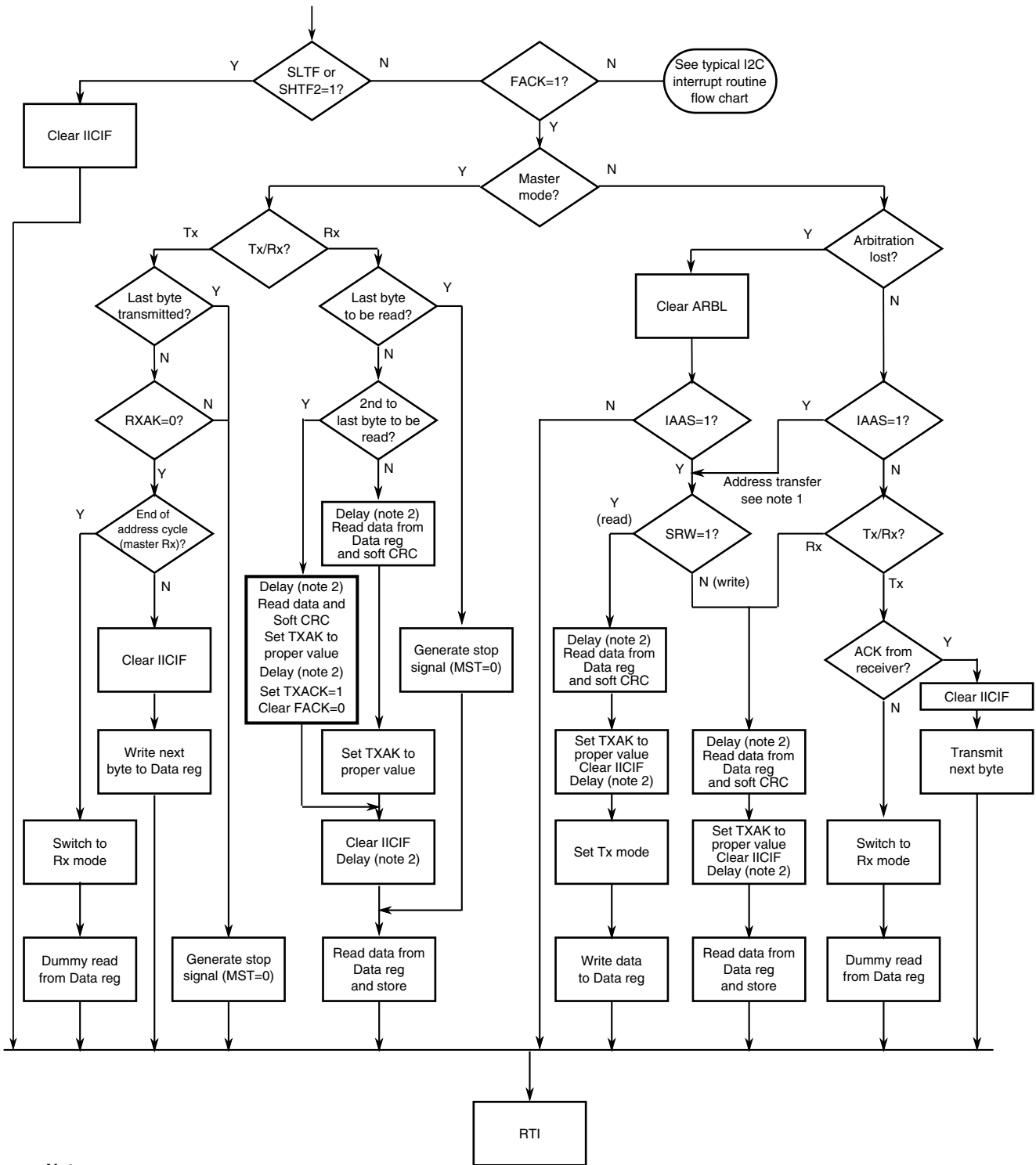

Notes:

1. If general call or SIICAEN is enabled, check to determine if the received address is a general call address (0x00) or an SMBus device default address. In either case, they must be handled by user software.
2. In receive mode, one bit time delay may be needed before the first and second data reading.

Figure 46-43. Typical I2C SMBus Interrupt Routine

Chapter 47

Universal Asynchronous Receiver/Transmitter (UART)

47.1 Introduction

NOTE

For the chip-specific implementation details of this module's instances see the chip configuration chapter.

The UART allows asynchronous serial communication with peripheral devices and CPUs.

47.1.1 Features

The UART includes these distinctive features:

- Full-duplex operation
- Standard mark/space non-return-to-zero (NRZ) format
- Selectable IrDA 1.4 return-to-zero-inverted (RZI) format with programmable pulse widths
- 13-bit baud rate selection with /32 fractional divide, based on module clock frequency
- Programmable 8-bit or 9-bit data format
- Separately enabled transmitter and receiver
- Programmable transmitter output polarity
- Programmable receive input polarity
- 13-bit break character option

- 11-bit break character detection option
- Independent FIFO structure for transmit and receive
- Two receiver wakeup methods:
 - Idle line wakeup
 - Address mark wakeup
- Address match feature in receiver to reduce address mark wakeup ISR overhead
- Ability to select MSB or LSB to be first bit on wire
- Hardware flow control support for request to send (RTS) and clear to send (CTS) signals
- Support for ISO 7816 protocol for interfacing with SIM cards and smart cards
 - Support of T=0 and T=1 protocols
 - Automatic retransmission of NACK'd packets with programmable retry threshold
 - Support for 11 and 12 ETU transfers
 - Detection of initial packet and automated transfer parameter programming
 - Interrupt-driven operation with seven ISO-7816 specific interrupts
 - Wait time violated
 - Character wait time violated
 - Block wait time violated
 - Initial frame detected
 - Transmit error threshold exceeded
 - Receive error threshold exceeded
 - Guard time violated
- Interrupt-driven operation with 12 flags (not specific to ISO-7816 support):
 - Transmitter data buffer at or below watermark
 - Transmission complete
 - Receiver data buffer at or above watermark
 - Idle receiver input

- Receiver data buffer overrun
- Receiver data buffer underflow
- Transmit data buffer overflow
- Noise error
- Framing error
- Parity error
- Active edge on receive pin
- LIN break detect
- Receiver framing error detection
- Hardware parity generation and checking
- 1/16 bit-time noise detection
- DMA interface

47.1.2 Modes of operation

The UART functions the same in all the normal modes.

It has two low power modes: Wait and Stop modes.

47.1.2.1 Run mode

This is the normal mode of operation.

47.1.2.2 Wait mode

UART operation in wait mode depends on the state of the C1[UARTSWAI] bit.

- If the C1[UARTSWAI] bit is cleared, the UART operates normally when the CPU is in Wait mode.
- If the C1[UARTSWAI] bit is set, UART clock generation ceases and the UART module enters a power-conservation state when the CPU is in Wait mode.

The C1[UARTSWAI] bit does not initiate any power down or power up procedures for the smartcard (ISO-7816) interface.

Setting C1[UARTSWAI] does not affect the state of the C2[RE], or C2[TE].

If C1[UARTSWAI] is set, any transmission or reception in progress stops at Wait mode entry. The transmission or reception resumes when either an internal or external interrupt brings the CPU out of Wait mode. Exiting Wait mode by reset aborts any transmission or reception in progress and resets the UART.

47.1.2.3 Stop mode

The UART is inactive during stop mode for reduced power consumption. The STOP instruction does not affect the UART register states, but the UART module clock will be disabled. The UART operation resumes from where it left off after an external interrupt brings the CPU out of stop mode. Exiting stop mode by reset aborts any transmission or reception in progress and resets the UART. Entering or leaving stop mode does not initiate any power down or power up procedures for the smartcard (ISO-7816) interface.

47.2 UART signal descriptions

The UART signals are shown in the following table.

Table 47-1. UART signal descriptions

Signal	Description	I/O
$\overline{\text{CTS}}$	Clear to send	I
$\overline{\text{RTS}}$	Request to send	O
RXD	Receive data	I
TXD	Transmit data	O

47.2.1 Detailed signal descriptions

The UART detailed signal descriptions are shown in the following table.

Table 47-2. UART—Detailed signal descriptions

Signal	I/O	Description
CTS	I	Clear to send. Indicates whether the UART can start to transmit data when flow control is enabled.
		State meaning Asserted—Data transmission can start. Negated—Data transmission can not start.
		Timing Assertion—When transmitting device's \overline{RTS} asserts. Negation—When transmitting device's \overline{RTS} deasserts.
RTS	O	Request to send. When driven by the receiver, indicates whether the UART is ready to receive data. When driven by the transmitter, can enable an external transceiver during transmission.
		State Meaning Asserted—When driven by the receiver, ready to receive data. When driven by the transmitter, enable the external transmitter. Negated—When driven by the receiver, not ready to receive data. When driven by the transmitter, disable the external transmitter.
		Timing Assertion—Can occur at any time; can assert asynchronously to the other input signals. Negation—Can occur at any time; can deassert asynchronously to the other input signals.
RXD	I	Receive data. Serial data input to receiver.
		State meaning Whether RXD is interpreted as a '1' or '0' depends on the bit encoding method along with other configuration settings.
		Timing Sampled at a frequency determined by the module clock divided by the baud rate.
TXD	O	Transmit data. Serial data output from transmitter.
		State meaning Whether TXD is interpreted as a '1' or '0' depends on the bit encoding method along with other configuration settings.
		Timing Driven at the beginning or within a bit time according to the bit encoding method along with other configuration settings. Otherwise, transmissions are independent of reception timing.

47.3 Memory map and registers

This section provides a detailed description of all memory and registers.

Accessing reserved addresses within the memory map will result in a transfer error. None of the contents of the implemented addresses will be modified as a result of that access.

Only byte accesses are supported.

UART memory map

Absolute address (hex)	Register name	Width (in bits)	Access	Reset value	Section/page
4006_A000	UART Baud Rate Registers:High (UART0_BDH)	8	R/W	00h	47.3.1/1249
4006_A001	UART Baud Rate Registers: Low (UART0_BDL)	8	R/W	04h	47.3.2/1251
4006_A002	UART Control Register 1 (UART0_C1)	8	R/W	00h	47.3.3/1252
4006_A003	UART Control Register 2 (UART0_C2)	8	R/W	00h	47.3.4/1253
4006_A004	UART Status Register 1 (UART0_S1)	8	R	C0h	47.3.5/1255
4006_A005	UART Status Register 2 (UART0_S2)	8	R/W	00h	47.3.6/1258
4006_A006	UART Control Register 3 (UART0_C3)	8	R/W	00h	47.3.7/1260
4006_A007	UART Data Register (UART0_D)	8	R/W	00h	47.3.8/1262
4006_A008	UART Match Address Registers 1 (UART0_MA1)	8	R/W	00h	47.3.9/1263
4006_A009	UART Match Address Registers 2 (UART0_MA2)	8	R/W	00h	47.3.10/1264
4006_A00A	UART Control Register 4 (UART0_C4)	8	R/W	00h	47.3.11/1264
4006_A00B	UART Control Register 5 (UART0_C5)	8	R/W	00h	47.3.12/1265
4006_A00C	UART Extended Data Register (UART0_ED)	8	R	00h	47.3.13/1266
4006_A00D	UART Modem Register (UART0_MODEM)	8	R/W	00h	47.3.14/1267
4006_A00E	UART Infrared Register (UART0_IR)	8	R/W	00h	47.3.15/1269
4006_A010	UART FIFO Parameters (UART0_PFIFO)	8	R/W	See section	47.3.16/1270
4006_A011	UART FIFO Control Register (UART0_CFIFO)	8	R/W	00h	47.3.17/1271
4006_A012	UART FIFO Status Register (UART0_SFIFO)	8	R/W	C0h	47.3.18/1272
4006_A013	UART FIFO Transmit Watermark (UART0_TWFIFO)	8	R/W	00h	47.3.19/1274
4006_A014	UART FIFO Transmit Count (UART0_TCFIFO)	8	R	00h	47.3.20/1274

Table continues on the next page...

UART memory map (continued)

Absolute address (hex)	Register name	Width (in bits)	Access	Reset value	Section/page
4006_A015	UART FIFO Receive Watermark (UART0_RWFIFO)	8	R/W	01h	47.3.21/1275
4006_A016	UART FIFO Receive Count (UART0_RCFIFO)	8	R	00h	47.3.22/1276
4006_A018	UART 7816 Control Register (UART0_C7816)	8	R/W	00h	47.3.23/1276
4006_A019	UART 7816 Interrupt Enable Register (UART0_IE7816)	8	R/W	00h	47.3.24/1278
4006_A01A	UART 7816 Interrupt Status Register (UART0_IS7816)	8	R/W	00h	47.3.25/1279
4006_A01B	UART 7816 Wait Parameter Register (UART0_WP7816T0)	8	R/W	0Ah	47.3.26/1281
4006_A01B	UART 7816 Wait Parameter Register (UART0_WP7816T1)	8	R/W	0Ah	47.3.27/1282
4006_A01C	UART 7816 Wait N Register (UART0_WN7816)	8	R/W	00h	47.3.28/1283
4006_A01D	UART 7816 Wait FD Register (UART0_WF7816)	8	R/W	01h	47.3.29/1283
4006_A01E	UART 7816 Error Threshold Register (UART0_ET7816)	8	R/W	00h	47.3.30/1284
4006_A01F	UART 7816 Transmit Length Register (UART0_TL7816)	8	R/W	00h	47.3.31/1285
4006_B000	UART Baud Rate Registers:High (UART1_BDH)	8	R/W	00h	47.3.1/1249
4006_B001	UART Baud Rate Registers: Low (UART1_BDL)	8	R/W	04h	47.3.2/1251
4006_B002	UART Control Register 1 (UART1_C1)	8	R/W	00h	47.3.3/1252
4006_B003	UART Control Register 2 (UART1_C2)	8	R/W	00h	47.3.4/1253
4006_B004	UART Status Register 1 (UART1_S1)	8	R	C0h	47.3.5/1255
4006_B005	UART Status Register 2 (UART1_S2)	8	R/W	00h	47.3.6/1258
4006_B006	UART Control Register 3 (UART1_C3)	8	R/W	00h	47.3.7/1260
4006_B007	UART Data Register (UART1_D)	8	R/W	00h	47.3.8/1262
4006_B008	UART Match Address Registers 1 (UART1_MA1)	8	R/W	00h	47.3.9/1263

Table continues on the next page...

UART memory map (continued)

Absolute address (hex)	Register name	Width (in bits)	Access	Reset value	Section/page
4006_B009	UART Match Address Registers 2 (UART1_MA2)	8	R/W	00h	47.3.10/1264
4006_B00A	UART Control Register 4 (UART1_C4)	8	R/W	00h	47.3.11/1264
4006_B00B	UART Control Register 5 (UART1_C5)	8	R/W	00h	47.3.12/1265
4006_B00C	UART Extended Data Register (UART1_ED)	8	R	00h	47.3.13/1266
4006_B00D	UART Modem Register (UART1_MODEM)	8	R/W	00h	47.3.14/1267
4006_B00E	UART Infrared Register (UART1_IR)	8	R/W	00h	47.3.15/1269
4006_B010	UART FIFO Parameters (UART1_PFIFO)	8	R/W	See section	47.3.16/1270
4006_B011	UART FIFO Control Register (UART1_CFIFO)	8	R/W	00h	47.3.17/1271
4006_B012	UART FIFO Status Register (UART1_SFIFO)	8	R/W	C0h	47.3.18/1272
4006_B013	UART FIFO Transmit Watermark (UART1_TWFIFO)	8	R/W	00h	47.3.19/1274
4006_B014	UART FIFO Transmit Count (UART1_TCFIFO)	8	R	00h	47.3.20/1274
4006_B015	UART FIFO Receive Watermark (UART1_RWFIFO)	8	R/W	01h	47.3.21/1275
4006_B016	UART FIFO Receive Count (UART1_RCFIFO)	8	R	00h	47.3.22/1276
4006_B018	UART 7816 Control Register (UART1_C7816)	8	R/W	00h	47.3.23/1276
4006_B019	UART 7816 Interrupt Enable Register (UART1_IE7816)	8	R/W	00h	47.3.24/1278
4006_B01A	UART 7816 Interrupt Status Register (UART1_IS7816)	8	R/W	00h	47.3.25/1279
4006_B01B	UART 7816 Wait Parameter Register (UART1_WP7816T0)	8	R/W	0Ah	47.3.26/1281
4006_B01B	UART 7816 Wait Parameter Register (UART1_WP7816T1)	8	R/W	0Ah	47.3.27/1282
4006_B01C	UART 7816 Wait N Register (UART1_WN7816)	8	R/W	00h	47.3.28/1283
4006_B01D	UART 7816 Wait FD Register (UART1_WF7816)	8	R/W	01h	47.3.29/1283

Table continues on the next page...

UART memory map (continued)

Absolute address (hex)	Register name	Width (in bits)	Access	Reset value	Section/page
4006_B01E	UART 7816 Error Threshold Register (UART1_ET7816)	8	R/W	00h	47.3.30/1284
4006_B01F	UART 7816 Transmit Length Register (UART1_TL7816)	8	R/W	00h	47.3.31/1285
4006_C000	UART Baud Rate Registers:High (UART2_BDH)	8	R/W	00h	47.3.1/1249
4006_C001	UART Baud Rate Registers: Low (UART2_BDL)	8	R/W	04h	47.3.2/1251
4006_C002	UART Control Register 1 (UART2_C1)	8	R/W	00h	47.3.3/1252
4006_C003	UART Control Register 2 (UART2_C2)	8	R/W	00h	47.3.4/1253
4006_C004	UART Status Register 1 (UART2_S1)	8	R	C0h	47.3.5/1255
4006_C005	UART Status Register 2 (UART2_S2)	8	R/W	00h	47.3.6/1258
4006_C006	UART Control Register 3 (UART2_C3)	8	R/W	00h	47.3.7/1260
4006_C007	UART Data Register (UART2_D)	8	R/W	00h	47.3.8/1262
4006_C008	UART Match Address Registers 1 (UART2_MA1)	8	R/W	00h	47.3.9/1263
4006_C009	UART Match Address Registers 2 (UART2_MA2)	8	R/W	00h	47.3.10/1264
4006_C00A	UART Control Register 4 (UART2_C4)	8	R/W	00h	47.3.11/1264
4006_C00B	UART Control Register 5 (UART2_C5)	8	R/W	00h	47.3.12/1265
4006_C00C	UART Extended Data Register (UART2_ED)	8	R	00h	47.3.13/1266
4006_C00D	UART Modem Register (UART2_MODEM)	8	R/W	00h	47.3.14/1267
4006_C00E	UART Infrared Register (UART2_IR)	8	R/W	00h	47.3.15/1269
4006_C010	UART FIFO Parameters (UART2_PFIFO)	8	R/W	See section	47.3.16/1270
4006_C011	UART FIFO Control Register (UART2_CFIFO)	8	R/W	00h	47.3.17/1271
4006_C012	UART FIFO Status Register (UART2_SFIFO)	8	R/W	C0h	47.3.18/1272

Table continues on the next page...

UART memory map (continued)

Absolute address (hex)	Register name	Width (in bits)	Access	Reset value	Section/page
4006_C013	UART FIFO Transmit Watermark (UART2_TWFIFO)	8	R/W	00h	47.3.19/1274
4006_C014	UART FIFO Transmit Count (UART2_TCFIFO)	8	R	00h	47.3.20/1274
4006_C015	UART FIFO Receive Watermark (UART2_RWFIFO)	8	R/W	01h	47.3.21/1275
4006_C016	UART FIFO Receive Count (UART2_RCFIFO)	8	R	00h	47.3.22/1276
4006_C018	UART 7816 Control Register (UART2_C7816)	8	R/W	00h	47.3.23/1276
4006_C019	UART 7816 Interrupt Enable Register (UART2_IE7816)	8	R/W	00h	47.3.24/1278
4006_C01A	UART 7816 Interrupt Status Register (UART2_IS7816)	8	R/W	00h	47.3.25/1279
4006_C01B	UART 7816 Wait Parameter Register (UART2_WP7816T0)	8	R/W	0Ah	47.3.26/1281
4006_C01B	UART 7816 Wait Parameter Register (UART2_WP7816T1)	8	R/W	0Ah	47.3.27/1282
4006_C01C	UART 7816 Wait N Register (UART2_WN7816)	8	R/W	00h	47.3.28/1283
4006_C01D	UART 7816 Wait FD Register (UART2_WF7816)	8	R/W	01h	47.3.29/1283
4006_C01E	UART 7816 Error Threshold Register (UART2_ET7816)	8	R/W	00h	47.3.30/1284
4006_C01F	UART 7816 Transmit Length Register (UART2_TL7816)	8	R/W	00h	47.3.31/1285
4006_D000	UART Baud Rate Registers:High (UART3_BDH)	8	R/W	00h	47.3.1/1249
4006_D001	UART Baud Rate Registers: Low (UART3_BDL)	8	R/W	04h	47.3.2/1251
4006_D002	UART Control Register 1 (UART3_C1)	8	R/W	00h	47.3.3/1252
4006_D003	UART Control Register 2 (UART3_C2)	8	R/W	00h	47.3.4/1253
4006_D004	UART Status Register 1 (UART3_S1)	8	R	C0h	47.3.5/1255
4006_D005	UART Status Register 2 (UART3_S2)	8	R/W	00h	47.3.6/1258
4006_D006	UART Control Register 3 (UART3_C3)	8	R/W	00h	47.3.7/1260

Table continues on the next page...

UART memory map (continued)

Absolute address (hex)	Register name	Width (in bits)	Access	Reset value	Section/page
4006_D007	UART Data Register (UART3_D)	8	R/W	00h	47.3.8/1262
4006_D008	UART Match Address Registers 1 (UART3_MA1)	8	R/W	00h	47.3.9/1263
4006_D009	UART Match Address Registers 2 (UART3_MA2)	8	R/W	00h	47.3.10/1264
4006_D00A	UART Control Register 4 (UART3_C4)	8	R/W	00h	47.3.11/1264
4006_D00B	UART Control Register 5 (UART3_C5)	8	R/W	00h	47.3.12/1265
4006_D00C	UART Extended Data Register (UART3_ED)	8	R	00h	47.3.13/1266
4006_D00D	UART Modem Register (UART3_MODEM)	8	R/W	00h	47.3.14/1267
4006_D00E	UART Infrared Register (UART3_IR)	8	R/W	00h	47.3.15/1269
4006_D010	UART FIFO Parameters (UART3_PFIFO)	8	R/W	See section	47.3.16/1270
4006_D011	UART FIFO Control Register (UART3_CFIFO)	8	R/W	00h	47.3.17/1271
4006_D012	UART FIFO Status Register (UART3_SFIFO)	8	R/W	C0h	47.3.18/1272
4006_D013	UART FIFO Transmit Watermark (UART3_TWFIFO)	8	R/W	00h	47.3.19/1274
4006_D014	UART FIFO Transmit Count (UART3_TCFIFO)	8	R	00h	47.3.20/1274
4006_D015	UART FIFO Receive Watermark (UART3_RWFIFO)	8	R/W	01h	47.3.21/1275
4006_D016	UART FIFO Receive Count (UART3_RCFIFO)	8	R	00h	47.3.22/1276
4006_D018	UART 7816 Control Register (UART3_C7816)	8	R/W	00h	47.3.23/1276
4006_D019	UART 7816 Interrupt Enable Register (UART3_IE7816)	8	R/W	00h	47.3.24/1278
4006_D01A	UART 7816 Interrupt Status Register (UART3_IS7816)	8	R/W	00h	47.3.25/1279
4006_D01B	UART 7816 Wait Parameter Register (UART3_WP7816T0)	8	R/W	0Ah	47.3.26/1281
4006_D01B	UART 7816 Wait Parameter Register (UART3_WP7816T1)	8	R/W	0Ah	47.3.27/1282

Table continues on the next page...

UART memory map (continued)

Absolute address (hex)	Register name	Width (in bits)	Access	Reset value	Section/page
4006_D01C	UART 7816 Wait N Register (UART3_WN7816)	8	R/W	00h	47.3.28/1283
4006_D01D	UART 7816 Wait FD Register (UART3_WF7816)	8	R/W	01h	47.3.29/1283
4006_D01E	UART 7816 Error Threshold Register (UART3_ET7816)	8	R/W	00h	47.3.30/1284
4006_D01F	UART 7816 Transmit Length Register (UART3_TL7816)	8	R/W	00h	47.3.31/1285
400E_A000	UART Baud Rate Registers:High (UART4_BDH)	8	R/W	00h	47.3.1/1249
400E_A001	UART Baud Rate Registers: Low (UART4_BDL)	8	R/W	04h	47.3.2/1251
400E_A002	UART Control Register 1 (UART4_C1)	8	R/W	00h	47.3.3/1252
400E_A003	UART Control Register 2 (UART4_C2)	8	R/W	00h	47.3.4/1253
400E_A004	UART Status Register 1 (UART4_S1)	8	R	C0h	47.3.5/1255
400E_A005	UART Status Register 2 (UART4_S2)	8	R/W	00h	47.3.6/1258
400E_A006	UART Control Register 3 (UART4_C3)	8	R/W	00h	47.3.7/1260
400E_A007	UART Data Register (UART4_D)	8	R/W	00h	47.3.8/1262
400E_A008	UART Match Address Registers 1 (UART4_MA1)	8	R/W	00h	47.3.9/1263
400E_A009	UART Match Address Registers 2 (UART4_MA2)	8	R/W	00h	47.3.10/1264
400E_A00A	UART Control Register 4 (UART4_C4)	8	R/W	00h	47.3.11/1264
400E_A00B	UART Control Register 5 (UART4_C5)	8	R/W	00h	47.3.12/1265
400E_A00C	UART Extended Data Register (UART4_ED)	8	R	00h	47.3.13/1266
400E_A00D	UART Modem Register (UART4_MODEM)	8	R/W	00h	47.3.14/1267
400E_A00E	UART Infrared Register (UART4_IR)	8	R/W	00h	47.3.15/1269
400E_A010	UART FIFO Parameters (UART4_PFIPO)	8	R/W	See section	47.3.16/1270

Table continues on the next page...

UART memory map (continued)

Absolute address (hex)	Register name	Width (in bits)	Access	Reset value	Section/page
400E_A011	UART FIFO Control Register (UART4_CFIFO)	8	R/W	00h	47.3.17/1271
400E_A012	UART FIFO Status Register (UART4_SFIFO)	8	R/W	C0h	47.3.18/1272
400E_A013	UART FIFO Transmit Watermark (UART4_TWFIFO)	8	R/W	00h	47.3.19/1274
400E_A014	UART FIFO Transmit Count (UART4_TCFIFO)	8	R	00h	47.3.20/1274
400E_A015	UART FIFO Receive Watermark (UART4_RWFIFO)	8	R/W	01h	47.3.21/1275
400E_A016	UART FIFO Receive Count (UART4_RCFIFO)	8	R	00h	47.3.22/1276
400E_A018	UART 7816 Control Register (UART4_C7816)	8	R/W	00h	47.3.23/1276
400E_A019	UART 7816 Interrupt Enable Register (UART4_IE7816)	8	R/W	00h	47.3.24/1278
400E_A01A	UART 7816 Interrupt Status Register (UART4_IS7816)	8	R/W	00h	47.3.25/1279
400E_A01B	UART 7816 Wait Parameter Register (UART4_WP7816T0)	8	R/W	0Ah	47.3.26/1281
400E_A01B	UART 7816 Wait Parameter Register (UART4_WP7816T1)	8	R/W	0Ah	47.3.27/1282
400E_A01C	UART 7816 Wait N Register (UART4_WN7816)	8	R/W	00h	47.3.28/1283
400E_A01D	UART 7816 Wait FD Register (UART4_WF7816)	8	R/W	01h	47.3.29/1283
400E_A01E	UART 7816 Error Threshold Register (UART4_ET7816)	8	R/W	00h	47.3.30/1284
400E_A01F	UART 7816 Transmit Length Register (UART4_TL7816)	8	R/W	00h	47.3.31/1285

47.3.1 UART Baud Rate Registers:High (UARTx_BDH)

This register, along with the BDL register, controls the prescale divisor for UART baud rate generation. To update the 13-bit baud rate setting (SBR[12:0]), first write to BDH to buffer the high half of the new value and then write to BDL. The working value in BDH does not change until BDL is written.

BDL is reset to a non-zero value, but after reset the baud rate generator remains disabled until the first time the receiver or transmitter is enabled (C2[RE] or C2[TE] bits are set).

memory map and registers

Addresses: UART0_BDH is 4006_A000h base + 0h offset = 4006_A000h

UART1_BDH is 4006_B000h base + 0h offset = 4006_B000h

UART2_BDH is 4006_C000h base + 0h offset = 4006_C000h

UART3_BDH is 4006_D000h base + 0h offset = 4006_D000h

UART4_BDH is 400E_A000h base + 0h offset = 400E_A000h

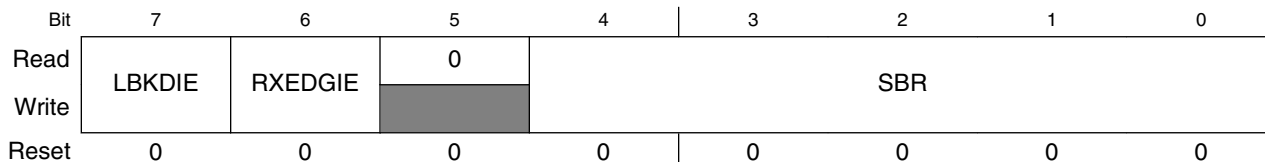

UARTx_BDH field descriptions

Field	Description
7 LBKDIE	<p>LIN Break Detect Interrupt Enable</p> <p>LBKDIE enables the LIN break detect flag, LBKDIF, to generate interrupt requests based on the state of LBKDDMAS.</p> <p>0 LBKDIF interrupt requests disabled. 1 LBKDIF interrupt requests enabled.</p>
6 RXEDGIE	<p>RxD Input Active Edge Interrupt Enable</p> <p>RXEDGIE enables the Receive input active edge, RXEDGIF, to generate interrupt requests.</p> <p>0 Hardware interrupts from RXEDGIF disabled (use polling). 1 RXEDGIF interrupt request enabled.</p>
5 Reserved	<p>This read-only field is reserved and always has the value zero.</p>
4–0 SBR	<p>UART Baud Rate Bits</p> <p>The baud rate for the UART is determined by these 13 bits. See Baud rate generation for details.</p> <p>NOTE: The baud rate generator is disabled until the C2[TE] bit or the C2[RE] bit is set for the first time after reset. The baud rate generator is disabled when SBR = 0.</p> <p>NOTE: Writing to BDH has no effect without writing to BDL, since writing to BDH puts the data in a temporary location until BDL is written.</p>

47.3.2 UART Baud Rate Registers: Low (UARTx_BDL)

This register, along with the BDH register, controls the prescale divisor for UART baud rate generation. To update the 13-bit baud rate setting (SBR[12:0]), first write to BDH to buffer the high half of the new value and then write to BDL. The working value in BDH does not change until BDL is written. BDL is reset to a non-zero value, but after reset the baud rate generator remains disabled until the first time the receiver or transmitter is enabled (C2[RE] or C2[TE] bits are set)

Addresses: UART0_BDL is 4006_A000h base + 1h offset = 4006_A001h

UART1_BDL is 4006_B000h base + 1h offset = 4006_B001h

UART2_BDL is 4006_C000h base + 1h offset = 4006_C001h

UART3_BDL is 4006_D000h base + 1h offset = 4006_D001h

UART4_BDL is 400E_A000h base + 1h offset = 400E_A001h

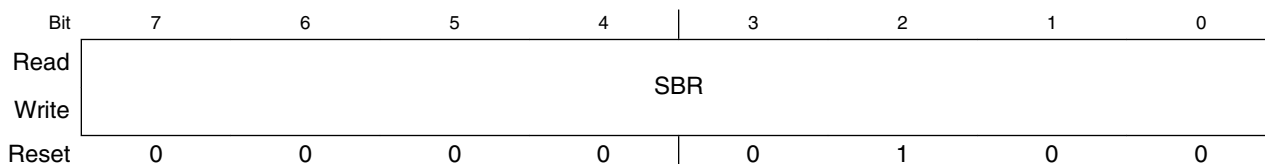

UARTx_BDL field descriptions

Field	Description
7-0 SBR	<p>UART Baud Rate Bits</p> <p>The baud rate for the UART is determined by these 13 bits. See Baud rate generation for details</p> <p>NOTE: The baud rate generator is disabled until the C2[TE] bit or the C2[RE] bit is set for the first time after reset. The baud rate generator is disabled when SBR = 0.</p> <p>NOTE: Writing to BDH has no effect without writing to BDL, since writing to BDH puts the data in a temporary location until BDL is written.</p> <p>NOTE: When the 1/32 narrow pulse width is selected for infrared (IrDA), the baud rate bits must be even, the least significant bit is 0. Refer to MODEM register.</p>

47.3.3 UART Control Register 1 (UARTx_C1)

This read/write register controls various optional features of the UART system.

Addresses: UART0_C1 is 4006_A000h base + 2h offset = 4006_A002h

UART1_C1 is 4006_B000h base + 2h offset = 4006_B002h

UART2_C1 is 4006_C000h base + 2h offset = 4006_C002h

UART3_C1 is 4006_D000h base + 2h offset = 4006_D002h

UART4_C1 is 400E_A000h base + 2h offset = 400E_A002h

Bit	7	6	5	4	3	2	1	0
Read	LOOPS	UARTSWAI	RSRC	M	WAKE	ILT	PE	PT
Write								
Reset	0	0	0	0	0	0	0	0

UARTx_C1 field descriptions

Field	Description
7 LOOPS	<p>Loop Mode Select</p> <p>When LOOPS is set, the RxD pin is disconnected from the UART and the transmitter output is internally connected to the receiver input. The transmitter and the receiver must be enabled to use the loop function.</p> <p>0 Normal operation. 1 Loop mode where transmitter output is internally connected to receiver input. The receiver input is determined by the RSRC bit.</p>
6 UARTSWAI	<p>UART Stops in Wait Mode</p> <p>0 UART clock continues to run in wait mode. 1 UART clock freezes while CPU is in wait mode.</p>
5 RSRC	<p>Receiver Source Select</p> <p>This bit has no meaning or effect unless the LOOPS bit is set. When LOOPS is set, the RSRC bit determines the source for the receiver shift register input.</p> <p>0 Selects internal loop back mode and receiver input is internally connected to transmitter output. 1 Single-wire UART mode where the receiver input is connected to the transmit pin input signal.</p>
4 M	<p>9-bit or 8-bit Mode Select</p> <p>This bit must be set when 7816E is set/enabled.</p> <p>0 Normal - start + 8 data bits (MSB/LSB first as determined by MSBF) + stop. 1 Use - start + 9 data bits (MSB/LSB first as determined by MSBF) + stop.</p>
3 WAKE	<p>Receiver Wakeup Method Select</p> <p>WAKE determines which condition wakes the UART: address mark in the most significant bit position of a received data character or an idle condition on the receive pin input signal.</p> <p>0 Idle-line wakeup. 1 Address-mark wakeup.</p>

Table continues on the next page...

UARTx_C1 field descriptions (continued)

Field	Description
2 ILT	<p>Idle Line Type Select</p> <p>ILT determines when the receiver starts counting logic 1s as idle character bits. The counting begins either after a valid start bit or after the stop bit. If the count begins after the start bit, then a string of logic 1s preceding the stop bit can cause false recognition of an idle character. Beginning the count after the stop bit avoids false idle character recognition, but requires properly synchronized transmissions.</p> <p>NOTE: In the case where UART is programmed with ILT = 1, a logic of 1'b0 is automatically shifted after a received stop bit thus resetting the idle count.</p> <p>NOTE: In the case where UART is programmed for IDLE line wakeup (RWU = 1 and WAKE = 0), ILT has no effect on when the receiver starts counting logic 1s as idle character bits. In idle line wakeup an idle character is recognized at anytime the receiver sees 10, 11, or 12 1s depending on the M, PE, and C4[M10] bits.</p> <p>0 Idle character bit count starts after start bit. 1 Idle character bit count starts after stop bit.</p>
1 PE	<p>Parity Enable</p> <p>Enables the parity function. When parity is enabled, parity function inserts a parity bit in the bit position immediately preceding the stop bit. This bit must be set when 7816E is set/enabled.</p> <p>0 Parity function disabled. 1 Parity function enabled.</p>
0 PT	<p>Parity Type</p> <p>PT determines whether the UART generates and checks for even parity or odd parity. With even parity, an even number of 1s clears the parity bit and an odd number of 1s sets the parity bit. With odd parity, an odd number of 1s clears the parity bit and an even number of 1s sets the parity bit. This bit must be cleared when 7816E is set/enabled.</p> <p>0 Even parity. 1 Odd parity.</p>

47.3.4 UART Control Register 2 (UARTx_C2)

This register can be read or written at any time.

Addresses: UART0_C2 is 4006_A000h base + 3h offset = 4006_A003h
 UART1_C2 is 4006_B000h base + 3h offset = 4006_B003h
 UART2_C2 is 4006_C000h base + 3h offset = 4006_C003h
 UART3_C2 is 4006_D000h base + 3h offset = 4006_D003h
 UART4_C2 is 400E_A000h base + 3h offset = 400E_A003h

Bit	7	6	5	4	3	2	1	0
Read	TIE	TCIE	RIE	ILIE	TE	RE	RWU	SBK
Write								
Reset	0	0	0	0	0	0	0	0

UARTx_C2 field descriptions

Field	Description
7 TIE	<p>Transmitter Interrupt or DMA Transfer Enable.</p> <p>TIE enables the S1[TDRE] flag, to generate interrupt requests or DMA transfer requests, based on the state of C5[TDMAS].</p> <p>NOTE: If C2[TIE] and C5[TDMAS] are both set, then TCIE must be cleared, and D[D] must not be written outside of servicing of a DMA request.</p> <p>0 TDRE interrupt and DMA transfer requests disabled. 1 TDRE interrupt or DMA transfer requests enabled.</p>
6 TCIE	<p>Transmission Complete Interrupt Enable</p> <p>TCIE enables the transmission complete flag, S1[TC], to generate interrupt requests.</p> <p>0 TC interrupt requests disabled. 1 TC interrupt requests enabled.</p>
5 RIE	<p>Receiver Full Interrupt or DMA Transfer Enable</p> <p>RIE enables the S1[RDRF] flag, to generate interrupt requests or DMA transfer requests, based on the state of C5[RDMAS].</p> <p>0 RDRF interrupt and DMA transfer requests disabled. 1 RDRF interrupt or DMA transfer requests enabled</p>
4 ILIE	<p>Idle Line Interrupt Enable</p> <p>ILIE enables the idle line flag, S1[IDLE], to generate interrupt requests, based on the state of C5[ILDMAS].</p> <p>0 IDLE interrupt requests disabled. 1 IDLE interrupt requests enabled.</p>
3 TE	<p>Transmitter Enable</p> <p>TE enables the UART transmitter. The TE bit can be used to queue an idle preamble by clearing and then setting the TE bit. When 7816E is set/enabled and C7816[TTYPE] = 1, this bit is automatically cleared after the requested block has been transmitted. This condition is detected when TL7816[TLEN] = 0 and four additional characters have been transmitted.</p> <p>0 Transmitter off. 1 Transmitter on.</p>
2 RE	<p>Receiver Enable</p> <p>RE enables the UART receiver.</p> <p>0 Receiver off. 1 Receiver on.</p>
1 RWU	<p>Receiver Wakeup Control</p> <p>This bit can be set to place the UART receiver in a standby state. RWU automatically clears when an RWU event occurs (an IDLE event when C1[WAKE] is clear or an address match when C1[WAKE] is set). This bit must be cleared when 7816E is set.</p>

Table continues on the next page...

UARTx_C2 field descriptions (continued)

Field	Description
	<p>NOTE: RWU should only be set with C1[WAKE] = 0 (wakeup on idle) if the channel is currently not idle. This can be determined by the S2[RAF] flag. If set to wake up an IDLE event and the channel is already idle, it is possible that the UART will discard data since data must be received (or a LIN break detect) after an IDLE is detected before IDLE is allowed to reasserted.</p> <p>0 Normal operation. 1 RWU enables the wakeup function and inhibits further receiver interrupt requests. Normally, hardware wakes the receiver by automatically clearing RWU.</p>
0 SBK	<p>Send Break</p> <p>Toggling SBK sends one break character (10, 11, or 12 logic 0s, if S2[BRK13] is cleared; 13 or 14 logic 0s, if S2[BRK13] is set). See Transmitting break characters for the number of logic 0s for the different configurations. Toggling implies clearing the SBK bit before the break character has finished transmitting. As long as SBK is set, the transmitter continues to send complete break characters (10, 11, or 12 bits, or 13 or 14 bits). This bit must be cleared when 7816E is set.</p> <p>0 Normal transmitter operation. 1 Queue break character(s) to be sent.</p>

47.3.5 UART Status Register 1 (UARTx_S1)

The S1 register provides inputs to the MCU for generation of UART interrupts or DMA requests. This register can also be polled by the MCU to check the status of these bits. To clear a flag, the status register should be read followed by a read or write (depending on interrupt flag type) to the UART Data Register. Other instructions can be executed between the two steps as long as it does not compromise the handling of I/O, but the order of operations is important for flag clearing. When a flag is configured to trigger a DMA request, assertion of the associated DMA done signal from the DMA controller, clears the flag.

NOTE

If the condition that results in the assertion of the flag, interrupt or DMA request is not resolved prior to clearing the flag, the flag (and interrupt/DMA request) will reassert. For example, if the DMA or interrupt service routine failed to write sufficient data to the transmit buffer to raise it above the watermark level, the flag will reassert and generate another interrupt or DMA request.

NOTE

Reading an empty data register to clear one of these flags causes the FIFO pointers to get out of alignment. A receive FIFO flush reinitializes the pointers.

memory map and registers

Addresses: UART0_S1 is 4006_A000h base + 4h offset = 4006_A004h

UART1_S1 is 4006_B000h base + 4h offset = 4006_B004h

UART2_S1 is 4006_C000h base + 4h offset = 4006_C004h

UART3_S1 is 4006_D000h base + 4h offset = 4006_D004h

UART4_S1 is 400E_A000h base + 4h offset = 400E_A004h

Bit	7	6	5	4	3	2	1	0
Read	TDRE	TC	RDRF	IDLE	OR	NF	FE	PF
Write								
Reset	1	1	0	0	0	0	0	0

UARTx_S1 field descriptions

Field	Description
7 TDRE	<p>Transmit Data Register Empty Flag</p> <p>TDRE will set when the number of datawords in the transmit buffer (D and C3[T8]) is equal to or less than the number indicated by TWFIFO[TXWATER]. A character that is in the process of being transmitted is not included in the count. To clear TDRE, read S1 when TDRE is set and then write to the UART data register (D). For more efficient interrupt servicing all data except the final value to be written to the buffer should be written to D/C3[T8]. Then S1 can be read before writing the final data value, resulting in the clearing of the TDRE flag. This is more efficient since the TDRE will reassert until the watermark has been exceeded so attempting to clear the TDRE every write will be ineffective until sufficient data has been written.</p> <p>0 The amount of data in the transmit buffer is greater than the value indicated by TWFIFO[TXWATER]. 1 The amount of data in the transmit buffer is less than or equal to the value indicated by TWFIFO[TXWATER] at some point in time since the flag has been cleared.</p>
6 TC	<p>Transmit Complete Flag</p> <p>TC is cleared when there is a transmission in progress or when a preamble or break character is loaded. TC is set when the transmit buffer is empty and no data, preamble, or break character is being transmitted. When TC is set, the transmit data output signal becomes idle (logic 1). When 7816E is set/enabled this bit is set after any NACK signal has been received but prior to any corresponding guard times expiring. TC is cleared by reading S1 with TC set and then doing one of the following:</p> <ul style="list-style-type: none"> • Writing to the UART data register (D) to transmit new data • Queuing a preamble by clearing and then setting the C2[TE] bit. • Queuing a break character by writing 1 to SBK in C2 <p>0 Transmitter active (sending data, a preamble, or a break). 1 Transmitter idle (transmission activity complete).</p>
5 RDRF	<p>Receive Data Register Full Flag</p> <p>RDRF is set when the number of datawords in the receive buffer is equal to or more than the number indicated by RWFIFO[RXWATER]. A dataword that is in the process of being received is not included in the count. RDRF is prevented from setting while S2[LBKDE] is set. Additionally, when S2[LBKDE] is set, datawords that are received will be stored in the receive buffer but will over-write each other. To clear RDRF, read S1 when RDRF is set and then read the UART data register (D). For more efficient interrupt and DMA operation all data except the final value is to be read from the buffer using D/C3[T8]/ED. The S1 should then be read and the final data value read, resulting in the clearing of the RDRF flag. Even if the RDRF flag is set, data will continue to be received until an overrun condition occurs.</p>

Table continues on the next page...

UARTx_S1 field descriptions (continued)

Field	Description
	<p>0 The number of datawords in the receive buffer is less than the number indicated by RXWATER.</p> <p>1 The number of datawords in the receive buffer is equal to or greater than the number indicated by RXWATER at some point in time since this flag was last cleared.</p>
4 IDLE	<p>Idle Line Flag</p> <p>IDLE is set when 10 consecutive logic 1s (if C1[M] = 0), 11 consecutive logic 1s (if C1[M] = 1 and C4[M10] = 0), or 12 consecutive logic 1s (if C1[M] = 1, C4[M10] = 1, and C1[PE] = 1) appear on the receiver input. After the IDLE flag is cleared, a frame must be received (although not necessarily stored in the data buffer, for example if C2[RWU] is set) or a LIN break character must set the S2[LBKDIF] flag before an idle condition can set the IDLE flag. To clear IDLE, read UART status S1 with IDLE set and then read D. Idle detection is not supported when 7816E is set/enabled and hence this flag is ignored.</p> <p>NOTE: When the receiver wakeup bit (RWU) is set and WAKE is cleared, an idle line condition sets the IDLE flag if RWUID is set, else the IDLE flag does not get set.</p> <p>0 Receiver input is either active now or has never become active since the IDLE flag was last cleared.</p> <p>1 Receiver input has become idle or the flag has not been cleared since it last asserted.</p>
3 OR	<p>Receiver Overrun Flag</p> <p>OR is set when software fails to prevent the receive data register from overflowing with data. The OR bit is set immediately after the stop bit has been completely received for the dataword that overflows the buffer and all the other error flags (FE,NF and PF) are prevented from setting. The data in the shift register is lost, but the data already in the UART data registers is not affected. If the OR flag is set, no data will be stored in the data buffer even if sufficient room exists. Additionally, while the OR flag is set the RDRF flag, and IDLE flags will be blocked from asserting, i.e. transition from an inactive to an active state. To clear OR, read S1 when OR is set and then read UART data register (D). If LBKDE is enabled and a LIN Break is detected, the OR bit will assert if the S2[LBKDIF] flag is not cleared before the next data character is received. See Overrun (OR) flag implications for more details regarding the operation of the OR bit. In 7816 mode, it is possible to configure a NACK to be returned by programming the C7816[ONACK] bit.</p> <p>0 No overrun has occurred since the last time the flag was cleared.</p> <p>1 Overrun has occurred or the overrun flag has not been cleared since the last overrun occurred.</p>
2 NF	<p>Noise Flag</p> <p>NF is set when the UART detects noise on the receiver input. NF bit does not get set in the case of an overrun or while the LIN break detect feature is enabled (S2[LBKDE] = 1). When NF is set, it only indicates that a dataword has been received with noise since the last time it was cleared. There is no guarantee that the first dataword read from the receive buffer has noise or that there is only one dataword in the buffer that was received with noise unless the receive buffer has a depth of one. To clear NF, read S1 and then read the UART data register (D).</p> <p>0 No noise detected since the last time this flag was cleared. If the receive buffer has a depth greater than 1 then there may be data in the receiver buffer that was received with noise.</p> <p>1 At least one dataword was received with noise detected since the last time the flag was cleared.</p>
1 FE	<p>Framing Error Flag</p> <p>FE is set when a logic 0 is accepted as the stop bit. FE bit does not set in the case of an overrun or while the LIN break detect feature is enabled (S2[LBKDE] = 1). FE inhibits further data reception until it is cleared. To clear FE, read S1 with FE set and then read the UART data register (D). The last data in the receive buffer represents the data that was received with the frame error enabled. However, framing errors are not supported when 7816E is set/enabled. However, if this flag is set, data will still not be received in 7816 mode.</p>

Table continues on the next page...

UARTx_S1 field descriptions (continued)

Field	Description
	0 No framing error detected. 1 Framing error.
0 PF	Parity Error Flag PF is set when PE is set, S2[LBKDE] is disabled, and the parity of the received data does not match its parity bit. The PF is not set in the case of an overrun condition. When the PF bit is set it only indicates that a dataword was received with parity error since the last time it was cleared. There is no guarantee that the first dataword read from the receive buffer has a parity error or that there is only one dataword in the buffer that was received with a parity error unless the receive buffer was a depth of one. To clear PF, read S1 and then read the UART data register (D). Within the receive buffer structure the received dataword is tagged if it was received with a parity error. That information is available by reading the ED register prior to reading the D register. 0 No parity error has been detected since the last time this flag was cleared. If the receive buffer has a depth greater than 1 then there may be data in the receive buffer what was received with a parity error. 1 At least one dataword was received with a parity error since the last time this flag was cleared.

47.3.6 UART Status Register 2 (UARTx_S2)

The S2 register provides inputs to the MCU for generation of UART interrupts or DMA requests. Also, this register can be polled by the MCU to check the status of these bits. This register can be read or written at any time, with the exception of the MSBF and RXINV bits which should only be changed by the user between transmit and receive packets.

Addresses: UART0_S2 is 4006_A000h base + 5h offset = 4006_A005h

UART1_S2 is 4006_B000h base + 5h offset = 4006_B005h

UART2_S2 is 4006_C000h base + 5h offset = 4006_C005h

UART3_S2 is 4006_D000h base + 5h offset = 4006_D005h

UART4_S2 is 400E_A000h base + 5h offset = 400E_A005h

Bit	7	6	5	4	3	2	1	0
Read	LBKDIF	RXEDGIF	MSBF	RXINV	RWUID	BRK13	LBKDE	RAF
Write								
Reset	0	0	0	0	0	0	0	0

UARTx_S2 field descriptions

Field	Description
7 LBKDIF	LIN Break Detect Interrupt Flag LBKDIF is set when LBKDE is set and a LIN break character is detected, when 11 consecutive logic 0s (if C1[M] = 0) or 12 consecutive logic 0s (if C1[M] = 1) appear on the receiver input. LBKDIF is set right after receiving the last LIN break character bit. LBKDIF is cleared by writing a 1 to it.

Table continues on the next page...

UARTx_S2 field descriptions (continued)

Field	Description
	<p>0 No LIN break character has been detected. 1 LIN break character has been detected.</p>
6 RXEDGIF	<p>RxD Pin Active Edge Interrupt Flag</p> <p>RXEDGIF is set when an active edge (falling if RXINV = 0, rising if RXINV=1) on the RxD pin occurs. RXEDGIF is cleared by writing a 1 to it. See RXEDGIF description for additional details.</p> <p>NOTE: The active edge is only detected when in two wire mode and on receive data coming from the RxD pin.</p> <p>0 No active edge on the receive pin has occurred. 1 An active edge on the receive pin has occurred.</p>
5 MSBF	<p>Most Significant Bit First</p> <p>Setting this bit reverses the order of the bits that are transmitted and received on the wire. This bit does not affect the polarity of the bits, the location of the parity bit or the location of the start or stop bits. This bit is automatically set or cleared when C7816[INIT] and C7816[ISO7816E] are enabled and an initial character is detected.</p> <p>0 LSB (bit0) is the first bit that is transmitted following the start bit. Further, the first bit received after the start bit is identified as bit0. 1 MSB (bit8, bit7 or bit6) is the first bit that is transmitted following the start bit depending on the setting of C1[M] and C1[PE]. Further, the first bit received after the start bit is identified as bit8, bit7 or bit6 depending on the setting of C1[M] and C1[PE].</p>
4 RXINV	<p>Receive Data Inversion</p> <p>Setting this bit, reverses the polarity of the received data input. In NRZ format, a one is represented by a mark and a zero is represented by a space for normal polarity, and the opposite for inverted polarity. In IrDA format, a zero is represented by short high pulse in the middle of a bit time remaining idle low for a one for normal polarity, and a zero is represented by short low pulse in the middle of a bit time remaining idle high for a one for inverted polarity. This bit is automatically set or cleared when C7816[INIT] and C7816[ISO7816E] are enabled and an initial character is detected.</p> <p>NOTE: Setting RXINV inverts the RxD input for: data bits, start and stop bits, break, and idle. When C7816[ISO7816E] is set/enabled then only the data bits and the parity bit are inverted.</p> <p>0 Receive data is not inverted. 1 Receive data is inverted.</p>
3 RWUID	<p>Receive Wakeup Idle Detect</p> <p>When RWU is set and WAKE is cleared, this bit controls whether the idle character that wakes the receiver sets the S1[IDLE] bit. This bit must be cleared when C7816[ISO7816E] is set/enabled.</p> <p>0 The S1[IDLE] bit is not set upon detection of an idle character. 1 The S1[IDLE] bit is set upon detection of an idle character.</p>
2 BRK13	<p>Break Transmit Character Length</p> <p>This bit determines whether the transmit break character is 10, 11, or 12 bits long, or 13 or 14 bits long. Refer to Transmitting break characters for the length of the break character for the different configurations. The detection of a framing error is not affected by this bit.</p> <p>0 Break character is 10, 11, or 12 bits long. 1 Break character is 13 or 14 bits long.</p>

Table continues on the next page...

UARTx_S2 field descriptions (continued)

Field	Description
1 LBKDE	<p>LIN Break Detection Enable</p> <p>LBKDE selects a longer break character detection length. While LBKDE is set, the S1[RDRF], S1[NF], S1[FE], and S1[PF] flags are prevented from setting. When LBKDE is set, see Overrun operation. The LBKDE bit must be cleared when C7816[ISO7816E] is set.</p> <p>0 Break character is detected at length of 10 bit times (C1[M] = 0), 11 (C1[M] = 1 and C4[M10] = 0), or 12 (C1[M] = 1, C4[M10] = 1, and S1[PE] = 1).</p> <p>1 Break character is detected at length of 11 bits times (if C1[M] = 0 or 12 bits time (if C1[M] = 1).</p>
0 RAF	<p>Receiver Active Flag</p> <p>RAF is set when the UART receiver detects a logic 0 during the RT1 time period of the start bit search. RAF is cleared when the receiver detects an idle character when C7816[ISO7816E] is cleared/disabled. When C7816[ISO7816E] is enabled the RAF is cleared if the C7816[TTYTYPE] = 0 expires or the C7816[TTYTYPE] = 1 expires.</p> <p>NOTE: In the case when C7816[ISO7816E] is set and C7816[TTYTYPE] = 0, it is possible to configure the guard time to be 12. However, in the event that a NACK is required to be transmitted the data transfer actually takes 13 ETU with the 13th ETU slot being an inactive buffer. Hence in this situation the RAF may deassert one ETU prior to actually being inactive.</p> <p>0 UART receiver idle/inactive waiting for a start bit.</p> <p>1 UART receiver active (RxD input not idle).</p>

47.3.7 UART Control Register 3 (UARTx_C3)

Writing to R8 bit does not have any effect. The TXDIR and TXINV bits can only be changed between transmit and receive packets.

Addresses: UART0_C3 is 4006_A000h base + 6h offset = 4006_A006h

UART1_C3 is 4006_B000h base + 6h offset = 4006_B006h

UART2_C3 is 4006_C000h base + 6h offset = 4006_C006h

UART3_C3 is 4006_D000h base + 6h offset = 4006_D006h

UART4_C3 is 400E_A000h base + 6h offset = 400E_A006h

Bit	7	6	5	4	3	2	1	0
Read	R8	T8	TXDIR	TXINV	ORIE	NEIE	FEIE	PEIE
Write								
Reset	0	0	0	0	0	0	0	0

UARTx_C3 field descriptions

Field	Description
7 R8	<p>Received Bit 8</p> <p>R8 is the ninth data bit received when the UART is configured for 9-bit data format (C1[M] = 1) or (C4[M10] = 1).</p>

Table continues on the next page...

UARTx_C3 field descriptions (continued)

Field	Description
6 T8	<p>Transmit Bit 8</p> <p>T8 is the ninth data bit transmitted when the UART is configured for 9-bit data format (C1[M] = 1) or (C4[M10] = 1).</p> <p>NOTE: If the value of T8 is the same as in the previous transmission, T8 does not have to be rewritten. The same value is transmitted until T8 is rewritten.</p>
5 TXDIR	<p>Transmitter Pin Data Direction in Single-Wire mode</p> <p>This bit determines whether the TXD pin is used as an input or output in the single-wire mode of operation. This bit is relevant only to the single-wire mode. When C7816[ISO7816E] is set/enabled and C7816[TTYTYPE] = 1, this bit is automatically cleared after the requested block has been transmitted. This condition is detected when TL7816[TLEN] = 0 and 4 additional characters have been transmitted. Additionally, if C7816[ISO7816E] is set/enabled and C7816[TTYTYPE] = 0 and a NACK is being transmitted, the hardware will automatically override this bit as needed. In this situation TXDIR will not reflect the temporary state associated with the NACK.</p> <p>0 TXD pin is an input in single-wire mode. 1 TXD pin is an output in single-wire mode.</p>
4 TXINV	<p>Transmit Data Inversion.</p> <p>Setting this bit reverses the polarity of the transmitted data output. In NRZ format, a one is represented by a mark and a zero is represented by a space for normal polarity, and the opposite for inverted polarity. In IrDA format, a zero is represented by short high pulse in the middle of a bit time remaining idle low for a one for normal polarity, and a zero is represented by short low pulse in the middle of a bit time remaining idle high for a one for inverted polarity. This bit is automatically set or cleared when C7816[INIT] and C7816[ISO7816E] are enabled and an initial character is detected.</p> <p>NOTE: Setting TXINV inverts all transmitted values, including idle, break, start, and stop bits. In loop mode, if TXINV is set, the receiver gets the transmit inversion bit when RXINV is disabled. When C7816[ISO7816E] is set/enabled then only the transmitted data bits and parity bit are inverted.</p> <p>0 Transmit data is not inverted. 1 Transmit data is inverted.</p>
3 ORIE	<p>Overrun Error Interrupt Enable</p> <p>This bit enables the overrun error flag (S1[OR]) to generate interrupt requests.</p> <p>0 OR interrupts are disabled. 1 OR interrupt requests are enabled.</p>
2 NEIE	<p>Noise Error Interrupt Enable</p> <p>This bit enables the noise flag (S1[NF]) to generate interrupt requests.</p> <p>0 NF interrupt requests are disabled. 1 NF interrupt requests are enabled.</p>
1 FEIE	<p>Framing Error Interrupt Enable</p> <p>This bit enables the framing error flag (S1[FE]) to generate interrupt requests.</p> <p>0 FE interrupt requests are disabled. 1 FE interrupt requests are enabled.</p>

Table continues on the next page...

UARTx_C3 field descriptions (continued)

Field	Description
0 PEIE	<p>Parity Error Interrupt Enable</p> <p>This bit enables the parity error flag (S1[PF]) to generate interrupt requests.</p> <p>0 PF interrupt requests are disabled. 1 PF interrupt requests are enabled.</p>

47.3.8 UART Data Register (UARTx_D)

This register is actually two separate registers. Reads return the contents of the read-only receive data register and writes go to the write-only transmit data register.

NOTE

In 8-bit or 9-bit data format, only UART data register (D) needs to be accessed in order to clear the S1[RDRF] bit (assuming receiver buffer level is less than RWFIFO[RXWATER]). The C3 register only needs to be read (prior to the D register) if the ninth bit of data needs to be captured. Likewise the ED register only needs to be read (prior to the D register) if the additional flag data for the dataword needs to be captured.

NOTE

In the normal 8-bit mode (M bit cleared) if the parity is enabled, you get seven data bits and one parity bit. That one parity bit will be loaded into the D register. So if you care about only the data bits, you have to mask off the parity bit from the value you read out of this register.

NOTE

When transmitting in 9-bit data format and using 8-bit write instructions, write first to transmit bit 8 in UART control register 3 (C3[T8]), then D. A write to C3[T8] stores the data in a temporary register. If D register is written first then the new data on data bus is stored in D register, while the temporary value (written by last write to C3[T8]) gets stored in C3[T8] register.

Addresses: UART0_D is 4006_A000h base + 7h offset = 4006_A007h
 UART1_D is 4006_B000h base + 7h offset = 4006_B007h
 UART2_D is 4006_C000h base + 7h offset = 4006_C007h
 UART3_D is 4006_D000h base + 7h offset = 4006_D007h
 UART4_D is 400E_A000h base + 7h offset = 400E_A007h

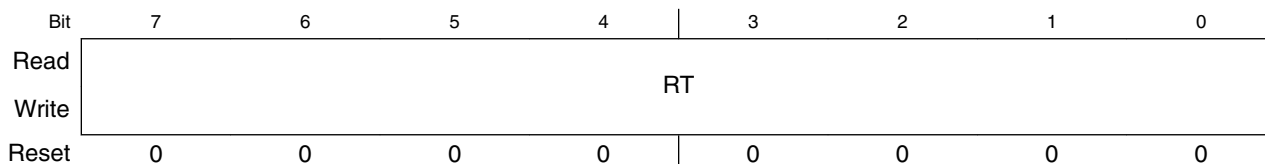

UARTx_D field descriptions

Field	Description
7-0 RT	Reads return the contents of the read-only receive data register and writes go to the write-only transmit data register.

47.3.9 UART Match Address Registers 1 (UARTx_MA1)

The MA1 and MA2 registers are compared to input data addresses when the most significant bit is set and the associated C4[MAEN] bit is set. If a match occurs, the following data is transferred to the data register. If a match fails, the following data is discarded. These registers can be read and written at anytime.

Addresses: UART0_MA1 is 4006_A000h base + 8h offset = 4006_A008h
 UART1_MA1 is 4006_B000h base + 8h offset = 4006_B008h
 UART2_MA1 is 4006_C000h base + 8h offset = 4006_C008h
 UART3_MA1 is 4006_D000h base + 8h offset = 4006_D008h
 UART4_MA1 is 400E_A000h base + 8h offset = 400E_A008h

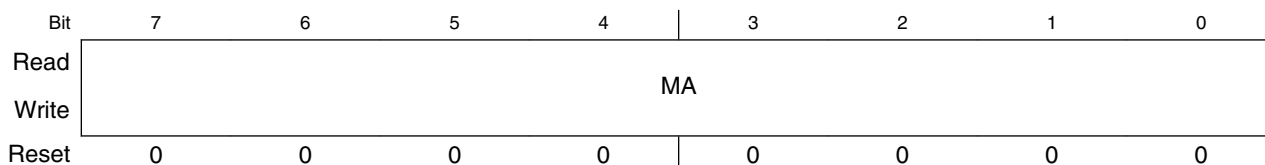

UARTx_MA1 field descriptions

Field	Description
7-0 MA	Match Address

47.3.10 UART Match Address Registers 2 (UARTx_MA2)

These registers can be read and written at anytime. The MA1 and MA2 registers are compared to input data addresses when the most significant bit is set and the associated C4[MAEN] bit is set. If a match occurs, the following data is transferred to the data register. If a match fails, the following data is discarded.

Addresses: UART0_MA2 is 4006_A000h base + 9h offset = 4006_A009h
 UART1_MA2 is 4006_B000h base + 9h offset = 4006_B009h
 UART2_MA2 is 4006_C000h base + 9h offset = 4006_C009h
 UART3_MA2 is 4006_D000h base + 9h offset = 4006_D009h
 UART4_MA2 is 400E_A000h base + 9h offset = 400E_A009h

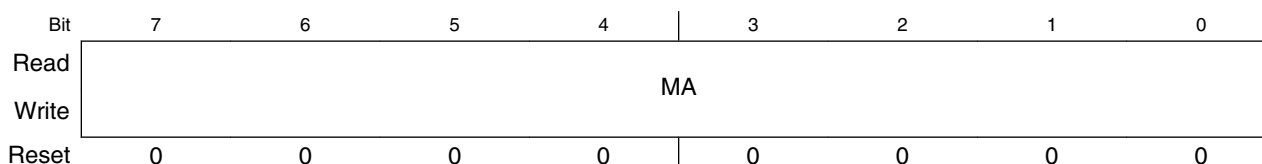

UARTx_MA2 field descriptions

Field	Description
7-0 MA	Match Address

47.3.11 UART Control Register 4 (UARTx_C4)

Addresses: UART0_C4 is 4006_A000h base + Ah offset = 4006_A00Ah
 UART1_C4 is 4006_B000h base + Ah offset = 4006_B00Ah
 UART2_C4 is 4006_C000h base + Ah offset = 4006_C00Ah
 UART3_C4 is 4006_D000h base + Ah offset = 4006_D00Ah
 UART4_C4 is 400E_A000h base + Ah offset = 400E_A00Ah

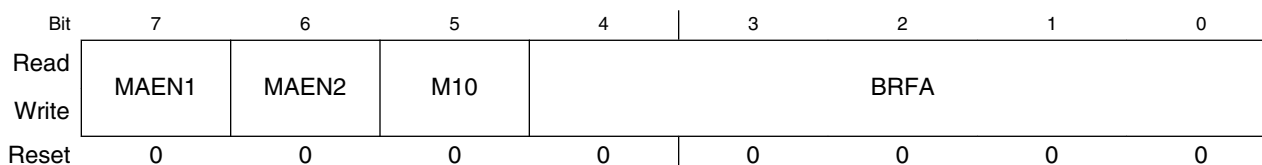

UARTx_C4 field descriptions

Field	Description
7 MAEN1	Match Address Mode Enable 1 Refer to Match address operation for more information.

Table continues on the next page...

UARTx_C4 field descriptions (continued)

Field	Description
	<p>0 All data received is transferred to the data buffer if MAEN2 is cleared.</p> <p>1 All data received with the most significant bit cleared, is discarded. All data received with the most significant bit set, is compared with contents of MA1 register. If no match occurs, the data is discarded. If match occurs, data is transferred to the data buffer. This bit must be cleared when C7816[ISO7816E] is set/enabled.</p>
6 MAEN2	<p>Match Address Mode Enable 2</p> <p>Refer to Match address operation for more information.</p> <p>0 All data received is transferred to the data buffer if MAEN1 is cleared.</p> <p>1 All data received with the most significant bit cleared, is discarded. All data received with the most significant bit set, is compared with contents of MA2 register. If no match occurs, the data is discarded. If match occurs, data is transferred to the data buffer. This bit must be cleared when C7816[ISO7816E] is set/enabled.</p>
5 M10	<p>10-bit Mode select</p> <p>The M10 bit causes a tenth, non-memory mapped bit to be part of the serial transmission. This tenth bit is generated and interpreted as a parity bit. The M10 bit does not affect the LIN send or detect break behavior. If M10 is set then both C1[M] and C1[PE] bits must also be set. This bit must be cleared when C7816[ISO7816E] is set/enabled. Refer to Data format (non ISO-7816) for more information.</p> <p>0 The parity bit is the ninth bit in the serial transmission.</p> <p>1 The parity bit is the tenth bit in the serial transmission.</p>
4-0 BRFA	<p>Baud Rate Fine Adjust</p> <p>This bit field is used to add more timing resolution to the average baud frequency, in increments of 1/32. Refer to Baud rate generation for more information.</p>

47.3.12 UART Control Register 5 (UARTx_C5)

Addresses: UART0_C5 is 4006_A000h base + Bh offset = 4006_A00Bh

UART1_C5 is 4006_B000h base + Bh offset = 4006_B00Bh

UART2_C5 is 4006_C000h base + Bh offset = 4006_C00Bh

UART3_C5 is 4006_D000h base + Bh offset = 4006_D00Bh

UART4_C5 is 400E_A000h base + Bh offset = 400E_A00Bh

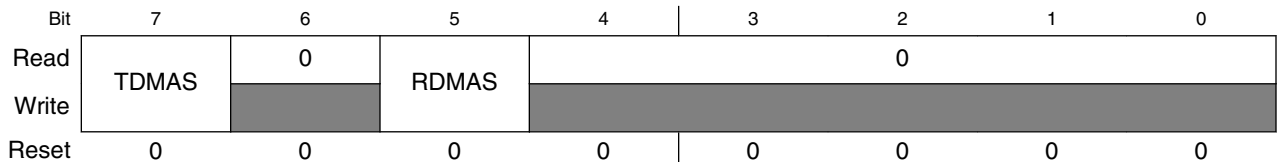

UARTx_C5 field descriptions

Field	Description
7 TDMAS	Transmitter DMA Select

Table continues on the next page...

UARTx_C5 field descriptions (continued)

Field	Description
	<p>TDMAS configures the transmit data register empty flag, S1[TDRE], to generate interrupt or DMA requests if C2[TIE] is set.</p> <p>NOTE: If C2[TIE] is cleared, TDRE DMA and TDRE interrupt request signals are not asserted when the TDRE flag is set, regardless of the state of TDMAS.</p> <p>NOTE: If C2[TIE] and TDMAS are both set, then C2[TCIE] must be cleared, and D register must not be written outside of servicing of a DMA request.</p> <p>0 If C2[TIE] is set and the S1[TDRE] flag is set, the TDRE interrupt request signal is asserted to request interrupt service.</p> <p>1 If C2[TIE] is set and the S1[TDRE] flag is set, the TDRE DMA request signal is asserted to request a DMA transfer.</p>
6 Reserved	This read-only field is reserved and always has the value zero.
5 RDMAS	<p>Receiver Full DMA Select</p> <p>RDMAS configures the receiver data register full flag, S1[RDRF], to generate interrupt or DMA requests if C2[RIE] is set.</p> <p>NOTE: If C2[RIE] is cleared, the RDRF DMA and RDRF interrupt request signals are not asserted when the S1[RDRF] flag is set, regardless of the state of RDMAS.</p> <p>0 If C2[RIE] is set and the S1[RDRF] flag is set, the RDRF interrupt request signal is asserted to request interrupt service.</p> <p>1 If C2[RIE] is set and the S1[RDRF] flag is set, the RDRF DMA request signal is asserted to request a DMA transfer.</p>
4-0 Reserved	This read-only field is reserved and always has the value zero.

47.3.13 UART Extended Data Register (UARTx_ED)

This register contains additional information flags that are stored with a received dataword. This register may be read at any time but only contains valid data if there is a dataword in the receive FIFO.

NOTE

The data contained in this register represents additional information regarding the conditions on which a dataword was received. The importance of this data varies with application, and in some cases maybe completely optional. These fields automatically update to reflect the conditions of the next dataword whenever D is read.

NOTE

If the S1[NF] and S1[PF] flags have not been set since the last time the receive buffer was empty, the NOISY and PARITYE bits will be zero.

Addresses: UART0_ED is 4006_A000h base + Ch offset = 4006_A00Ch

UART1_ED is 4006_B000h base + Ch offset = 4006_B00Ch

UART2_ED is 4006_C000h base + Ch offset = 4006_C00Ch

UART3_ED is 4006_D000h base + Ch offset = 4006_D00Ch

UART4_ED is 400E_A000h base + Ch offset = 400E_A00Ch

Bit	7	6	5	4	3	2	1	0
Read	NOISY	PARITYE	0					
Write								
Reset	0	0	0	0	0	0	0	0

UARTx_ED field descriptions

Field	Description
7 NOISY	The current received dataword contained in D and C3[R8] was received with noise. 0 The dataword was received without noise. 1 The data was received with noise.
6 PARITYE	The current received dataword contained in D and C3[R8] was received with a parity error. 0 The dataword was received without a parity error. 1 The dataword was received with a parity error.
5-0 Reserved	This read-only field is reserved and always has the value zero.

47.3.14 UART Modem Register (UARTx_MODEM)

The MODEM register controls options for setting the modem configuration.

NOTE

RXRTSE, TXRTSPOL, TXRTSE and TXCTSE must all be cleared when C7816[ISO7816EN] is enabled. This will cause the RTS to deassert during ISO-7816 wait times. The ISO-7816 protocol does not make use of the RTS and CTS signals.

memory map and registers

Addresses: UART0_MODEM is 4006_A000h base + Dh offset = 4006_A00Dh

UART1_MODEM is 4006_B000h base + Dh offset = 4006_B00Dh

UART2_MODEM is 4006_C000h base + Dh offset = 4006_C00Dh

UART3_MODEM is 4006_D000h base + Dh offset = 4006_D00Dh

UART4_MODEM is 400E_A000h base + Dh offset = 400E_A00Dh

Bit	7	6	5	4	3	2	1	0
Read	0				RXRTSE	TXRTSPOL	TXRTSE	TXCTSE
Write								
Reset	0	0	0	0	0	0	0	0

UARTx_MODEM field descriptions

Field	Description
7-4 Reserved	This read-only field is reserved and always has the value zero.
3 RXRTSE	Receiver request-to-send enable Allows the RTS output to control the CTS input of the transmitting device to prevent receiver overrun. NOTE: Do not set both RXRTSE and TXRTSE. 0 The receiver has no effect on RTS. 1 RTS is deasserted if the number of characters in the receiver data register (FIFO) is equal to or greater than RWFIFO[RXWATER]. RTS is asserted when the number of characters in the receiver data register (FIFO) is less than RWFIFO[RXWATER].
2 TXRTSPOL	Transmitter request-to-send polarity Controls the polarity of the transmitter RTS. TXRTSPOL does not affect the polarity of the receiver RTS. RTS will remain negated in the active low state unless TXRTSE is set. 0 Transmitter RTS is active low. 1 Transmitter RTS is active high.
1 TXRTSE	Transmitter request-to-send enable Controls RTS before and after a transmission. 0 The transmitter has no effect on RTS. 1 When a character is placed into an empty transmitter data buffer(FIFO), RTS asserts one bit time before the start bit is transmitted. RTS deasserts one bit time after all characters in the transmitter data buffer(FIFO) and shift register are completely sent, including the last stop bit.
0 TXCTSE	Transmitter clear-to-send enable TXCTSE controls the operation of the transmitter. TXCTSE can be set independently from the state of TXRTSE and RXRTSE. 0 CTS has no effect on the transmitter. 1 Enables clear-to-send operation. The transmitter checks the state of CTS each time it is ready to send a character. If CTS is asserted, the character is sent. If CTS is deasserted, the signal TXD remains in the mark state and transmission is delayed until CTS is asserted. Changes in CTS as a character is being sent do not affect its transmission.

47.3.15 UART Infrared Register (UARTx_IR)

The IR register controls options for setting the infrared configuration.

Addresses: UART0_IR is 4006_A000h base + Eh offset = 4006_A00Eh

UART1_IR is 4006_B000h base + Eh offset = 4006_B00Eh

UART2_IR is 4006_C000h base + Eh offset = 4006_C00Eh

UART3_IR is 4006_D000h base + Eh offset = 4006_D00Eh

UART4_IR is 400E_A000h base + Eh offset = 400E_A00Eh

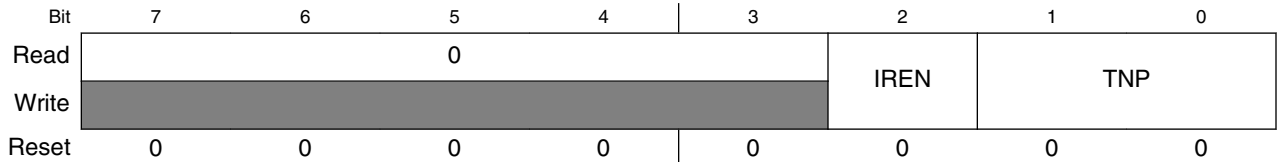

UARTx_IR field descriptions

Field	Description
7–3 Reserved	This read-only field is reserved and always has the value zero.
2 IREN	Infrared enable This bit enables/disables the infrared modulation/demodulation. 0 IR disabled. 1 IR enabled.
1–0 TNP	Transmitter narrow pulse These bits enable whether the UART transmits a 1/16, 3/16, 1/32 or 1/4 narrow pulse. 00 3/16. 01 1/16. 10 1/32. 11 1/4.

47.3.16 UART FIFO Parameters (UARTx_PFIFO)

This register provides the ability for the programmer to turn on and off FIFO functionality. It also provides the size of the FIFO that has been implemented. This register may be read at any time. This register should only be written when the C2[RE] and C2[TE] bits are cleared / not set and when the data buffer/FIFO is empty.

Addresses: UART0_PFIFO is 4006_A000h base + 10h offset = 4006_A010h

UART1_PFIFO is 4006_B000h base + 10h offset = 4006_B010h

UART2_PFIFO is 4006_C000h base + 10h offset = 4006_C010h

UART3_PFIFO is 4006_D000h base + 10h offset = 4006_D010h

UART4_PFIFO is 400E_A000h base + 10h offset = 400E_A010h

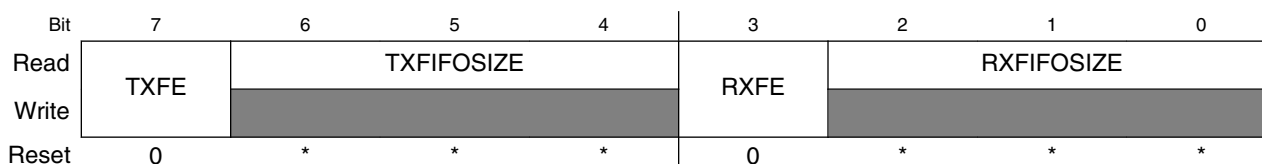

* Notes:

- TXFIFOSIZE bitfield: The reset value depends on whether the specific UART instance supports the FIFO and on the size of that FIFO. See the Chip Configuration details for more information on the FIFO size supported for each UART instance.
- RXFIFOSIZE bitfield: The reset value depends on whether the specific UART instance supports the FIFO and on the size of that FIFO. See the Chip Configuration details for more information on the FIFO size supported for each UART instance.

UARTx_PFIFO field descriptions

Field	Description
7 TXFE	<p>Transmit FIFO Enable</p> <p>When this bit is set the built in FIFO structure for the transmit buffer is enabled. The size of the FIFO structure is indicated by the TXFIFOSIZE field. If this bit is not set then the transmit buffer operates as a FIFO of depth one dataword regardless of the value in TXFIFOSIZE. Both C2[TE] and C2[RE] must be cleared prior to changing this bit. Additionally TXFLUSH and RXFLUSH commands should be issued immediately after changing this bit.</p> <p>0 Transmit FIFO is not enabled. Buffer is depth 1. (Legacy support). 1 Transmit FIFO is enabled. Buffer is depth indicted by TXFIFOSIZE.</p>
6-4 TXFIFOSIZE	<p>Transmit FIFO. Buffer Depth</p> <p>The maximum number of transmit datawords that can be stored in the transmit buffer. This field is read only.</p> <p>000 Transmit FIFO/Buffer Depth = 1 Dataword. 001 Transmit FIFO/Buffer Depth = 4 Datawords. 010 Transmit FIFO/Buffer Depth = 8 Datawords. 011 Transmit FIFO/Buffer Depth = 16 Datawords. 100 Transmit FIFO/Buffer Depth = 32 Datawords.</p>

Table continues on the next page...

UARTx_PFIFO field descriptions (continued)

Field	Description
	101 Transmit FIFO/Buffer Depth = 64 Datawords. 110 Transmit FIFO/Buffer Depth = 128 Datawords. 111 Reserved.
3 RXFE	Receive FIFO Enable When this bit is set the built in FIFO structure for the receive buffer is enabled. The size of the FIFO structure is indicated by the RXFIFOSIZE field. If this bit is not set then the receive buffer operates as a FIFO of depth one dataword regardless of the value in RXFIFOSIZE. Both C2[TE] and C2[RE] must be cleared prior to changing this bit. Additionally TXFLUSH and RXFLUSH commands should be issued immediately after changing this bit. 0 Receive FIFO is not enabled. Buffer is depth 1. (Legacy support) 1 Receive FIFO is enabled. Buffer is depth indicated by RXFIFOSIZE.
2-0 RXFIFOSIZE	Receive FIFO. Buffer Depth The maximum number of receive datawords that can be stored in the receive buffer before an overrun occurs. This field is read only. 000 Receive FIFO/Buffer Depth = 1 Dataword. 001 Receive FIFO/Buffer Depth = 4 Datawords. 010 Receive FIFO/Buffer Depth = 8 Datawords. 011 Receive FIFO/Buffer Depth = 16 Datawords. 100 Receive FIFO/Buffer Depth = 32 Datawords. 101 Receive FIFO/Buffer Depth = 64 Datawords. 110 Receive FIFO/Buffer Depth = 128 Datawords. 111 Reserved.

47.3.17 UART FIFO Control Register (UARTx_CFIFO)

This register provides the ability to program various control bits for FIFO operation. This register may be read or written at any time. Note that writing the TXFLUSH and RXFLUSH bits may result in data loss and requires careful action to prevent unintended / unpredictable behavior, hence it is recommended that TE and RE be cleared prior to flushing the corresponding FIFO.

Addresses: UART0_CFIFO is 4006_A000h base + 11h offset = 4006_A011h
 UART1_CFIFO is 4006_B000h base + 11h offset = 4006_B011h
 UART2_CFIFO is 4006_C000h base + 11h offset = 4006_C011h
 UART3_CFIFO is 4006_D000h base + 11h offset = 4006_D011h
 UART4_CFIFO is 400E_A000h base + 11h offset = 400E_A011h

Bit	7	6	5	4	3	2	1	0
Read	0	0	0				TXOFE	RXUFE
Write	TXFLUSH	RXFLUSH						
Reset	0	0	0	0	0	0	0	0

UARTx_CFIFO field descriptions

Field	Description
7 TXFLUSH	<p>Transmit FIFO/Buffer Flush</p> <p>Writing to this bit causes all data that is stored in the transmit FIFO/buffer to be flushed. This does not affect data that is in the transmit shift register.</p> <p>0 No flush operation occurs. 1 All data in the transmit FIFO/Buffer is cleared out.</p>
6 RXFLUSH	<p>Receive FIFO/Buffer Flush</p> <p>Writing to this bit causes all data that is stored in the receive FIFO/buffer to be flushed. This does not affect data that is in the receive shift register.</p> <p>0 No flush operation occurs. 1 All data in the receive FIFO/buffer is cleared out.</p>
5-2 Reserved	This read-only field is reserved and always has the value zero.
1 TXOFE	<p>Transmit FIFO Overflow Interrupt Enable</p> <p>When this bit is set the TXOF flag will generate an interrupt to the host.</p> <p>0 TXOF flag does not generate an interrupt to the host. 1 TXOF flag generates an interrupt to the host.</p>
0 RXUFE	<p>Receive FIFO Underflow Interrupt Enable</p> <p>When this bit is set the RXUF flag will generate an interrupt to the host.</p> <p>0 RXUF flag does not generate an interrupt to the host. 1 RXUF flag generates an interrupt to the host.</p>

47.3.18 UART FIFO Status Register (UARTx_SFIFO)

This register provides various status information regarding the transmit and receiver buffers/FIFOs, including interrupt information. This register may be written or read at anytime.

Addresses: UART0_SFIFO is 4006_A000h base + 12h offset = 4006_A012h

UART1_SFIFO is 4006_B000h base + 12h offset = 4006_B012h

UART2_SFIFO is 4006_C000h base + 12h offset = 4006_C012h

UART3_SFIFO is 4006_D000h base + 12h offset = 4006_D012h

UART4_SFIFO is 400E_A000h base + 12h offset = 400E_A012h

Bit	7	6	5	4	3	2	1	0
Read	TXEMPT	RXEMPT	0				TXOF	RXUF
Write								
Reset	1	1	0	0	0	0	0	0

UARTx_SFIFO field descriptions

Field	Description
7 TXEMPT	<p>Transmit Buffer/FIFO Empty</p> <p>This status bit asserts when there is no data in the Transmit FIFO/buffer. This bit does not take into account data that is in the transmit shift register.</p> <p>0 Transmit buffer is not empty. 1 Transmit buffer is empty.</p>
6 RXEMPT	<p>Receive Buffer/FIFO Empty</p> <p>This status bit asserts when there is no data in the receive FIFO/Buffer. This bit does not take into account data that is in the receive shift register.</p> <p>0 Receive buffer is not empty. 1 Receive buffer is empty.</p>
5–2 Reserved	<p>This read-only field is reserved and always has the value zero.</p>
1 TXOF	<p>Transmitter Buffer Overflow Flag</p> <p>This flag indicates that more data has been written to the transmit buffer than it can hold. This bit will assert regardless of the value of CFIFO[TXOF]. However, an interrupt will only be issued to the host if the CFIFO[TXOF] bit is set. This flag is cleared by writing a "1".</p> <p>0 No transmit buffer overflow has occurred since the last time the flag was cleared. 1 At least one transmit buffer overflow has occurred since the last time the flag was cleared.</p>
0 RXUF	<p>Receiver Buffer Underflow Flag</p> <p>This flag indicates that more data has been read from the receive buffer than was present. This bit will assert regardless of the value of CFIFO[RXUF]. However, an interrupt will only be issued to the host if the CFIFO[RXUF] bit is set. This flag is cleared by writing a "1".</p> <p>0 No receive buffer underflow has occurred since the last time the flag was cleared. 1 At least one receive buffer underflow has occurred since the last time the flag was cleared.</p>

47.3.19 UART FIFO Transmit Watermark (UARTx_TWFIFO)

This register provides the ability to set a programmable threshold for notification of needing additional transmit data. This register may be read at any time but should only be written when C2[TE] is not set. Changing the value of the watermark will not clear the S1[TDRE] flag.

Addresses: UART0_TWFIFO is 4006_A000h base + 13h offset = 4006_A013h

UART1_TWFIFO is 4006_B000h base + 13h offset = 4006_B013h

UART2_TWFIFO is 4006_C000h base + 13h offset = 4006_C013h

UART3_TWFIFO is 4006_D000h base + 13h offset = 4006_D013h

UART4_TWFIFO is 400E_A000h base + 13h offset = 400E_A013h

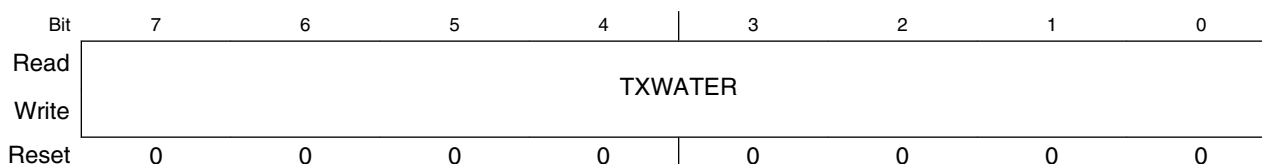

UARTx_TWFIFO field descriptions

Field	Description
7-0 TXWATER	<p>Transmit Watermark</p> <p>When the number of datawords in the transmit FIFO/buffer is equal to or less than the value in this register field then an interrupt via S1[TDRE] or a DMA request via C5[TDMAS] will be generated as determined by C5[TDMAS] and C2[TIE] fields. For proper operation the value in the TXWATER field must be set to be less than the size of the transmit buffer/FIFO size as indicated by PFIFO[TXFIFOSIZE] and PFIFO[TXFE].</p>

47.3.20 UART FIFO Transmit Count (UARTx_TCFIFO)

This is a read only register that indicates how many datawords are currently in the transmit buffer/FIFO. It may be read at anytime.

Addresses: UART0_TCFIFO is 4006_A000h base + 14h offset = 4006_A014h

UART1_TCFIFO is 4006_B000h base + 14h offset = 4006_B014h

UART2_TCFIFO is 4006_C000h base + 14h offset = 4006_C014h

UART3_TCFIFO is 4006_D000h base + 14h offset = 4006_D014h

UART4_TCFIFO is 400E_A000h base + 14h offset = 400E_A014h

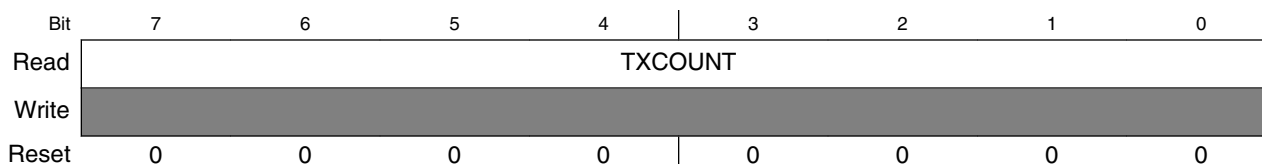

UARTx_TCFIFO field descriptions

Field	Description
7-0 TXCOUNT	<p>Transmit Counter</p> <p>The value in this register indicates the number of datawords that are in the transmit buffer/FIFO. If a dataword is in the process of being transmitted (i.e. in the transmit shift register) it is not included in the count. This value may be used in conjunction with the PFIFO[TXFIFOSIZE] field to calculate how much room is left in the transmit buffer/FIFO.</p>

47.3.21 UART FIFO Receive Watermark (UARTx_RWFIFO)

This register provides the ability to set a programmable threshold for notification of needing to remove data from the receiver buffer/FIFO. This register may be read at any time but should only be written when C2[RE] is not asserted. Changing the value in this register will not clear the S1[RDRF] flag.

Addresses: UART0_RWFIFO is 4006_A000h base + 15h offset = 4006_A015h

UART1_RWFIFO is 4006_B000h base + 15h offset = 4006_B015h

UART2_RWFIFO is 4006_C000h base + 15h offset = 4006_C015h

UART3_RWFIFO is 4006_D000h base + 15h offset = 4006_D015h

UART4_RWFIFO is 400E_A000h base + 15h offset = 400E_A015h

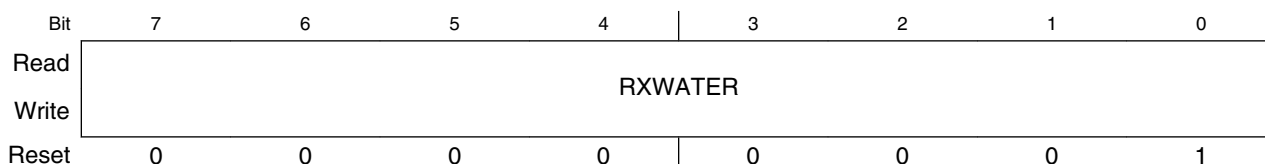

UARTx_RWFIFO field descriptions

Field	Description
7-0 RXWATER	<p>Receive Watermark</p> <p>When the number of datawords in the Receive FIFO/buffer is equal to or greater than the value in this register field the event is flagged. An interrupt via S1[RDRF] or a DMA request via C5[RDMAS] will be generated as determined by C5[RDMAS] and C2[RIE] fields. For proper operation the value in the RXWATER field must be set to be less than the size of the Receive buffer/FIFO size as indicated by PFIFO[RXFIFOSIZE] and PFIFO[RXFE] and greater than 0.</p>

47.3.22 UART FIFO Receive Count (UARTx_RCFIFO)

This is a read only register that indicates how many datawords are currently in the receive buffer/FIFO. It may be read at anytime.

Addresses: UART0_RCFIFO is 4006_A000h base + 16h offset = 4006_A016h
 UART1_RCFIFO is 4006_B000h base + 16h offset = 4006_B016h
 UART2_RCFIFO is 4006_C000h base + 16h offset = 4006_C016h
 UART3_RCFIFO is 4006_D000h base + 16h offset = 4006_D016h
 UART4_RCFIFO is 400E_A000h base + 16h offset = 400E_A016h

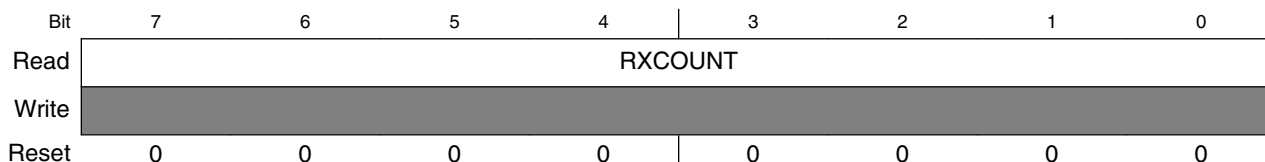

UARTx_RCFIFO field descriptions

Field	Description
7-0 RXCOUNT	<p>Receive Counter</p> <p>The value in this register indicates the number of datawords that are in the receive buffer/FIFO. If a dataword is in the process of being received (i.e. in the receive shift register) it is not included in the count. This value may be used in conjunction with the PFIFO[RXFIFOSIZE] field to calculate how much room is left in the receive buffer/FIFO.</p>

47.3.23 UART 7816 Control Register (UARTx_C7816)

The C7816 register is the primary control register for ISO-7816 specific functionality. This register is specific to 7816 functionality and the values in this register have no effect on UART operation and should be ignored if ISO_7816E is not set/enabled. This register may be read at anytime but values should only be changed when the ISO_7816E bit is not set.

Addresses: UART0_C7816 is 4006_A000h base + 18h offset = 4006_A018h
 UART1_C7816 is 4006_B000h base + 18h offset = 4006_B018h
 UART2_C7816 is 4006_C000h base + 18h offset = 4006_C018h
 UART3_C7816 is 4006_D000h base + 18h offset = 4006_D018h
 UART4_C7816 is 400E_A000h base + 18h offset = 400E_A018h

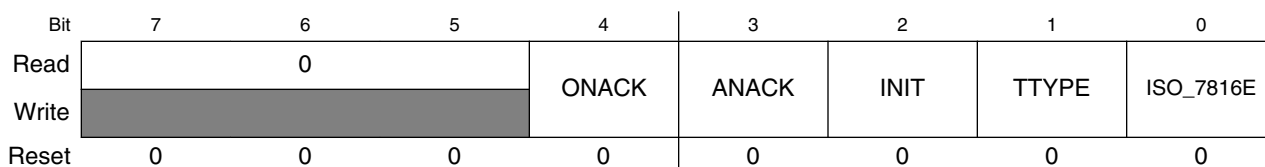

UARTx_C7816 field descriptions

Field	Description
7-5 Reserved	This read-only field is reserved and always has the value zero.
4 ONACK	<p>Generate NACK on Overflow</p> <p>When this bit is set, the receiver will automatically generate a NACK response if a receive buffer overrun occurs as indicated by the S1[OR] field. In many systems this will result in the transmitter resending the packet that overflowed until the retransmit threshold for that transmitter has been reached. A NACK is only generated if TTYPE=0. This bit operates independently of ANACK. See Overrun NACK considerations.</p> <p>0 The received data does not generate a NACK when the receipt of the data results in an overflow event. 1 If the receiver buffer overflows, a NACK is automatically sent on a received character.</p>
3 ANACK	<p>Generate NACK on Error</p> <p>When this bit is set, the receiver will automatically generate a NACK response if a parity error occurs or if INIT is set and an invalid initial character is detected. A NACK is only generated if TTYPE = 0. If ANACK is set the UART will attempt to retransmit the data indefinitely. To stop retransmission attempts, clear C2[TE] or ISO_7816E and do not set until S1[TC] set C2[TE] again.</p> <p>0 No NACK is automatically generated. 1 A NACK is automatically generated if a parity error is detected or if an invalid initial character is detected.</p>
2 INIT	<p>Detect Initial Character</p> <p>When this bit is set, all received characters will be searched for a valid initial character. If an invalid initial character is identified then a NACK will be sent if ANACK is set. All received data is discarded and error flags blocked (S1[NF], S1[OR], S1[FE], S1[PF], IS7816[WT], IS7816[CWT], IS7816[BWT], IS7816[GTV]) until a valid initial character is detected. Upon detection of a valid initial character the configuration values S2[MSBF], C3[TXINV] and S2[RXINV] are automatically updated to reflect the initial character that was received. The actual INIT data value is not stored in the receive buffer. Additionally, upon detection of a valid initial character the IS7816[INITD] flag is set and an interrupt issued as programmed by the IE7816[INITDE] bit. When a valid initial character is detected the INIT bit is automatically cleared.</p> <p>0 Normal operating mode. Receiver does not seek to identify initial character. 1 Receiver searches for initial character.</p>
1 TTYPE	<p>Transfer Type</p> <p>This bit indicates the transfer protocol being used. Refer to ISO-7816 / smartcard support for more details.</p> <p>0 T = 0 Per the ISO-7816 specification. 1 T = 1 Per the ISO-7816 specification.</p>
0 ISO_7816E	<p>ISO-7816 Functionality Enabled</p> <p>This bit indicates that the UART is operating according to the ISO-7816 protocol.</p> <p>NOTE: This bit should only be modified when no transmit or receive is occurring. If this bit is changed during a data transfer the data being transmitted or received may be transferred incorrectly.</p> <p>0 ISO-7816 functionality is turned off / not enabled. 1 ISO-7816 functionality is turned on / enabled.</p>

47.3.24 UART 7816 Interrupt Enable Register (UARTx_IE7816)

The IE7816 register controls which flags result in an interrupt being issued. This register is specific to 7816 functionality, the corresponding flags that drive the interrupts will not assert when 7816E is not set/enabled. However, these flags may remain set if they asserted while 7816E was set and not subsequently cleared. This register maybe read or written at anytime.

Addresses: UART0_IE7816 is 4006_A000h base + 19h offset = 4006_A019h

UART1_IE7816 is 4006_B000h base + 19h offset = 4006_B019h

UART2_IE7816 is 4006_C000h base + 19h offset = 4006_C019h

UART3_IE7816 is 4006_D000h base + 19h offset = 4006_D019h

UART4_IE7816 is 400E_A000h base + 19h offset = 400E_A019h

Bit	7	6	5	4	3	2	1	0
Read					0			
Write	WTE	CWTE	BWTE	INITDE		GTVE	TXTE	RXTE
Reset	0	0	0	0	0	0	0	0

UARTx_IE7816 field descriptions

Field	Description
7 WTE	Wait Timer Interrupt Enable 0 The assertion of the IS7816[WT] bit will not result in the generation of an interrupt. 1 The assertion of the IS7816[WT] bit will result in the generation of an interrupt.
6 CWTE	Character Wait Timer Interrupt Enable 0 The assertion of the IS7816[CWT] bit will not result in the generation of an interrupt. 1 The assertion of the IS7816[CWT] bit will result in the generation of an interrupt.
5 BWTE	Block Wait Timer Interrupt Enable 0 The assertion of the IS7816[BWT] bit will not result in the generation of an interrupt. 1 The assertion of the IS7816[BWT] bit will result in the generation of an interrupt.
4 INITDE	Initial Character Detected Interrupt Enable 0 The assertion of the IS7816[INITD] bit will not result in the generation of an interrupt. 1 The assertion of the IS7816[INITD] bit will result in the generation of an interrupt.
3 Reserved	This read-only field is reserved and always has the value zero.
2 GTVE	Guard Timer Violated Interrupt Enable 0 The assertion of the IS7816[GTV] bit will not result in the generation of an interrupt. 1 The assertion of the IS7816[GTV] bit will result in the generation of an interrupt.
1 TXTE	Transmit Threshold Exceeded Interrupt Enable

Table continues on the next page...

UARTx_IE7816 field descriptions (continued)

Field	Description
	0 The assertion of the IS7816[TXT] bit will not result in the generation of an interrupt. 1 The assertion of the IS7816[TXT] bit will result in the generation of an interrupt.
0 RXTE	Receive Threshold Exceeded Interrupt Enable 0 The assertion of the IS7816[RXT] bit will not result in the generation of an interrupt. 1 The assertion of the IS7816[RXT] bit will result in the generation of an interrupt.

47.3.25 UART 7816 Interrupt Status Register (UARTx_IS7816)

The IS7816 register provides a mechanism to read and clear the interrupt flags. All flags/interrupts are cleared by writing a "1" to the bit location. Writing a "0" has no effect. All bits are "sticky", meaning they only indicate that the flag condition occurred since the last time the bit was cleared not that the condition currently exists. The status flags are set regardless of if the corresponding bit in the IC7816 is set or cleared, the IC7816 only controls if a interrupt is issued to the host processor. This register is specific to 7816 functionality and the values in this register have no affect on UART operation and should be ignored if 7816E is not set/enabled. This register may be read or written at anytime.

Addresses: UART0_IS7816 is 4006_A000h base + 1Ah offset = 4006_A01Ah

UART1_IS7816 is 4006_B000h base + 1Ah offset = 4006_B01Ah

UART2_IS7816 is 4006_C000h base + 1Ah offset = 4006_C01Ah

UART3_IS7816 is 4006_D000h base + 1Ah offset = 4006_D01Ah

UART4_IS7816 is 400E_A000h base + 1Ah offset = 400E_A01Ah

Bit	7	6	5	4	3	2	1	0
Read	WT	CWT	BWT	INITD	0	GTV	TXT	RXT
Write								
Reset	0	0	0	0	0	0	0	0

UARTx_IS7816 field descriptions

Field	Description
7 WT	Wait Timer Interrupt This flag indicates that the wait time, the time between the leading edge of a character being transmitted and the leading edge of the next response character has exceeded the programed value. This flag only asserts when C7816[TTYTYPE] = 0. This interrupt is cleared by writing `1'. 0 Wait time (WT) has not been violated. 1 Wait time (WT) has been violated.
6 CWT	Character Wait Timer Interrupt

Table continues on the next page...

UARTx_IS7816 field descriptions (continued)

Field	Description
	<p>This flag indicates that the character wait time, the time between the leading edges of two consecutive characters in a block has exceed the prograded value. This flag only asserts when C7816[TTYTYPE] = 1. This interrupt is cleared by writing `1'.</p> <p>0 Character wait time (CWT) has not been violated. 1 Character wait time (CWT) has been violated.</p>
5 BWT	<p>Block Wait Timer Interrupt</p> <p>This flag indicates that the block wait time, the time between the leading edge of first received character of a block and the leading edge of the last character the previously transmitted block. This flag only asserts when C7816[TTYTYPE] = 1. This interrupt is cleared by writing '1'.</p> <p>0 Block wait time (BWT) has not been violated. 1 Block wait tTime (BWT) has been violated.</p>
4 INITD	<p>Initial Character Detected Interrupt</p> <p>This flag indicates that a valid initial character was received. This interrupt is cleared by writing `1'.</p> <p>0 A valid initial character has not been received. 1 A valid initial character has been received.</p>
3 Reserved	<p>This read-only field is reserved and always has the value zero.</p>
2 GTV	<p>Guard Timer Violated Interrupt</p> <p>This flag indicates that one or more of the character guard time, block guard time or guard time were violated. This interrupt is cleared by writing `1'.</p> <p>0 A guard time (GT, CGT or BGT) has not been violated. 1 A guard time (GT, CGT or BGT) has been violated.</p>
1 TXT	<p>Transmit Threshold Exceeded Interrupt</p> <p>This flag indicates that the transmit NACK threshold has been exceeded as indicated by the ET7816[TXTHRESHOLD] field. Regardless if this flag is set, the UART will continue to retransmit indefinitely. This flag only asserts when C7816[TTYTYPE] = 0. If 7816E is cleared/disabled, ANACK is cleared/disabled, C2[TE] is cleared/disabled, C7816[TTYTYPE] = 1 or packet is transferred without receiving a NACK the internal NACK detection counter is cleared and the count restarts from zero on the next received NACK. This interrupt is cleared by writing `1'.</p> <p>0 The number of retries and corresponding NACKS does not exceed the value in the ET7816[TXTHRESHOLD] field. 1 The number of retries and corresponding NACKS exceeds the value in the ET7816[TXTHRESHOLD] field.</p>
0 RXT	<p>Receive Threshold Exceeded Interrupt</p> <p>This flag indicates that there were more than ET7816[RXTHRESHOLD] consecutive NACKS generated in response to parity errors on received data. This flag requires ANACK to be set. Additionally, this flag only asserts when C7816[TTYTYPE] = 0. Clearing this bit also resets the counter keeping track of consecutive NACKS. The UART will continue to attempt to receive data regardless of if this flag is set. If 7816E is cleared/disabled, RE is cleared/disabled, C7816[TTYTYPE] = 1 or packet is received without needing to issue a NACK, the internal NACK detection counter is cleared and the count restarts from zero on the next transmitted NACK. This interrupt is cleared by writing `1'.</p>

Table continues on the next page...

UARTx_IS7816 field descriptions (continued)

Field	Description
0	The number of consecutive NACKS generated as a result of parity errors and buffer overruns is less than or equal to the value in ET7816[RXTHRESHOLD].
1	The number of consecutive NACKS generated as a result of parity errors and buffer overruns is greater than the value in ET7816[RXTHRESHOLD].

47.3.26 UART 7816 Wait Parameter Register (UARTx_WP7816T0)

The WP7816 register contains constants used in the generation of various wait timer counters. To save register space this register is used differently when C7816[TTYTYPE] = 0 and C7816[TTYTYPE] = 1. This register may be read at anytime. This register must only be written when C7816[ISO_7816E] is not set.

Addresses: UART0_WP7816T0 is 4006_A000h base + 1Bh offset = 4006_A01Bh
 UART1_WP7816T0 is 4006_B000h base + 1Bh offset = 4006_B01Bh
 UART2_WP7816T0 is 4006_C000h base + 1Bh offset = 4006_C01Bh
 UART3_WP7816T0 is 4006_D000h base + 1Bh offset = 4006_D01Bh
 UART4_WP7816T0 is 400E_A000h base + 1Bh offset = 400E_A01Bh

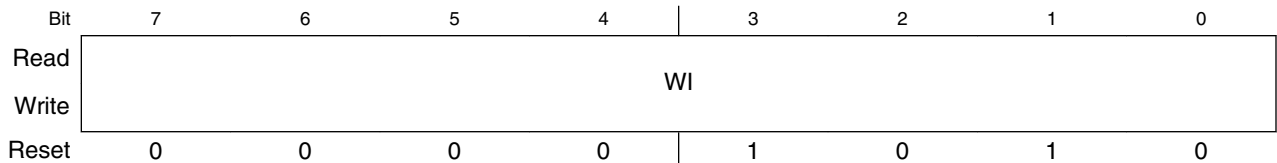

UARTx_WP7816T0 field descriptions

Field	Description
7-0 WI	Wait Timer Interrupt (C7816[TTYTYPE] = 0) This value is used to calculate the value used for the WT counter. It represents a value between 1 and 255. The value of zero is not valid. This value is only used when C7816[TTYTYPE] = 0. See Wait time and guard time parameters .

47.3.27 UART 7816 Wait Parameter Register (UARTx_WP7816T1)

The WP7816 register contains constants used in the generation of various wait timer counters. To save register space this register is used differently when C7816[TTYTYPE] = 0 and C7816[TTYTYPE] = 1. This register may be read at anytime. This register must only be written when C7816[ISO_7816E] is not set.

Addresses: UART0_WP7816T1 is 4006_A000h base + 1Bh offset = 4006_A01Bh

UART1_WP7816T1 is 4006_B000h base + 1Bh offset = 4006_B01Bh

UART2_WP7816T1 is 4006_C000h base + 1Bh offset = 4006_C01Bh

UART3_WP7816T1 is 4006_D000h base + 1Bh offset = 4006_D01Bh

UART4_WP7816T1 is 400E_A000h base + 1Bh offset = 400E_A01Bh

Bit	7	6	5	4	3	2	1	0
Read	CWI				BWI			
Write								
Reset	0	0	0	0	1	0	1	0

UARTx_WP7816T1 field descriptions

Field	Description
7-4 CWI	Character Wait Time Integer (C7816[TTYTYPE] = 1) This value is used to calculate the value used for the CWT counter. It represents a value between 0 and 15. This value is only used when C7816[TTYTYPE] = 1. See Wait time and guard time parameters .
3-0 BWI	Block Wait Time Integer(C7816[TTYTYPE] = 1) This value is used to calculate the value used for the BWT counter. It represent a value between 0 and 15. This value is only used when C7816[TTYTYPE] = 1. See Wait time and guard time parameters .

47.3.28 UART 7816 Wait N Register (UARTx_WN7816)

The WN7816 register contains a parameter that is used in the calculation of the guard time counter. This register may be read at anytime. This register must only be written when C7816[ISO_7816E] is not set.

Addresses: UART0_WN7816 is 4006_A000h base + 1Ch offset = 4006_A01Ch
 UART1_WN7816 is 4006_B000h base + 1Ch offset = 4006_B01Ch
 UART2_WN7816 is 4006_C000h base + 1Ch offset = 4006_C01Ch
 UART3_WN7816 is 4006_D000h base + 1Ch offset = 4006_D01Ch
 UART4_WN7816 is 400E_A000h base + 1Ch offset = 400E_A01Ch

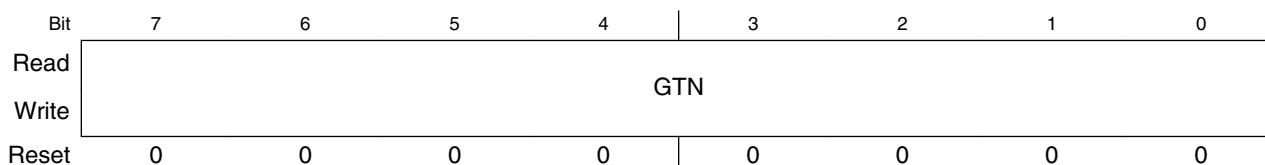

UARTx_WN7816 field descriptions

Field	Description
7-0 GTN	Guard Band N This register field defines a parameter used in the calculation of GT, CGT and BGT counters. The value represents an integer number 0-255. See Wait time and guard time parameters .

47.3.29 UART 7816 Wait FD Register (UARTx_WF7816)

The WF7816 contains parameters that are used in the generation of various counters including GT, CGT, BGT, WT and BWT. This register may be read from at anytime. This register must only be written to when C7816[ISO_7816E] is not set.

Addresses: UART0_WF7816 is 4006_A000h base + 1Dh offset = 4006_A01Dh
 UART1_WF7816 is 4006_B000h base + 1Dh offset = 4006_B01Dh
 UART2_WF7816 is 4006_C000h base + 1Dh offset = 4006_C01Dh
 UART3_WF7816 is 4006_D000h base + 1Dh offset = 4006_D01Dh
 UART4_WF7816 is 400E_A000h base + 1Dh offset = 400E_A01Dh

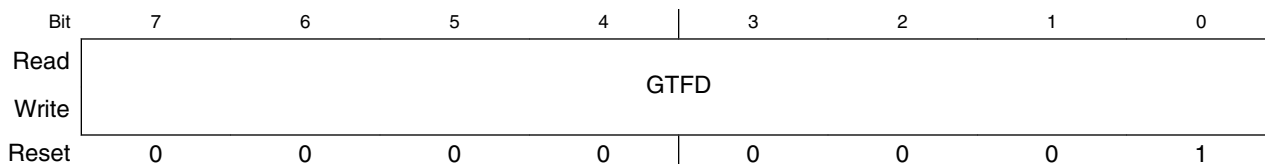

UARTx_WF7816 field descriptions

Field	Description
7-0 GTFD	<p>FD Multiplier</p> <p>This field is used as another multiplier in the calculation of WT and BWT. This values represents a number between 1 and 255. The value of 0 is invalid. This value is NOT used in baud rate generation. See Wait time and guard time parameters and Baud rate generation.</p>

47.3.30 UART 7816 Error Threshold Register (UARTx_ET7816)

The ET7816 register contains fields that determine the number of NACKs that must be received or transmitted before the host processor is notified. This register may be read at anytime. This register must only be written when C7816[ISO_7816E] is not set.

Addresses: UART0_ET7816 is 4006_A000h base + 1Eh offset = 4006_A01Eh
 UART1_ET7816 is 4006_B000h base + 1Eh offset = 4006_B01Eh
 UART2_ET7816 is 4006_C000h base + 1Eh offset = 4006_C01Eh
 UART3_ET7816 is 4006_D000h base + 1Eh offset = 4006_D01Eh
 UART4_ET7816 is 400E_A000h base + 1Eh offset = 400E_A01Eh

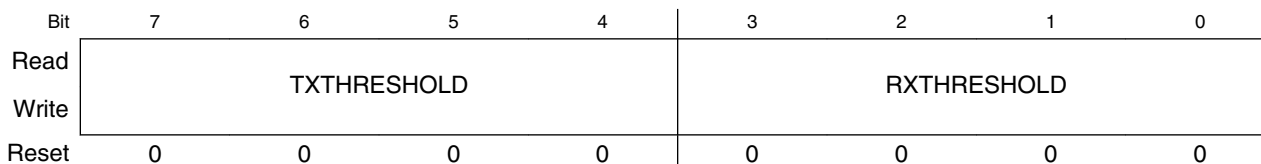

UARTx_ET7816 field descriptions

Field	Description
7-4 TXTHRESHOLD	<p>Transmit NACK Threshold</p> <p>The value written to this field indicates the maximum number of failed attempts (NACKs) a transmitted character can have before the host processor is notified. Meaning a value of 0 will always result in TXT asserting on the first NACK that is received. A value of 1 will result in TXT being asserted on the second NACK that is received. This field is only meaningful when C7816[TTYTYPE] = 0 and C7816[ANACK] = 1. The value read from this field represents the number of consecutive NACKs that have been received since the last successful transmission. This counter saturates at 4'hF and does not wrap around. Regardless of how many NACKs that are received, the UART will continue to retransmit indefinitely. This flag only asserts when C7816[TTYTYPE] = 0. For additional information see the IS7816[TXT] bit description.</p>
3-0 RXTHRESHOLD	<p>Receive NACK Threshold</p> <p>The value written to this field indicates the maximum number of consecutive NACKs generated as a result of a parity error or receiver buffer overruns before the host processor is notified. Once the counter exceeds that value in the field the IS7816[RXT] will be asserted. This field is only meaningful when C7816[TTYTYPE] = 0. The value read from this field represents the number of consecutive NACKs that have been transmitted since the last successful reception. This counter saturates at 4'hF and does not wrap around. Regardless of the number of NACKs sent, the UART will continue to receive valid packets indefinitely. For additional information see IS7816[RXT] bit description.</p>

47.3.31 UART 7816 Transmit Length Register (UARTx_TL7816)

The TL7816 register is used to indicate how many characters are contained in the block being transmitted. This register is only used when C7816[TTYTYPE] = 1. This register may be read at anytime. This register should only be written when C2[TE] is not enabled.

Addresses: UART0_TL7816 is 4006_A000h base + 1Fh offset = 4006_A01Fh

UART1_TL7816 is 4006_B000h base + 1Fh offset = 4006_B01Fh

UART2_TL7816 is 4006_C000h base + 1Fh offset = 4006_C01Fh

UART3_TL7816 is 4006_D000h base + 1Fh offset = 4006_D01Fh

UART4_TL7816 is 400E_A000h base + 1Fh offset = 400E_A01Fh

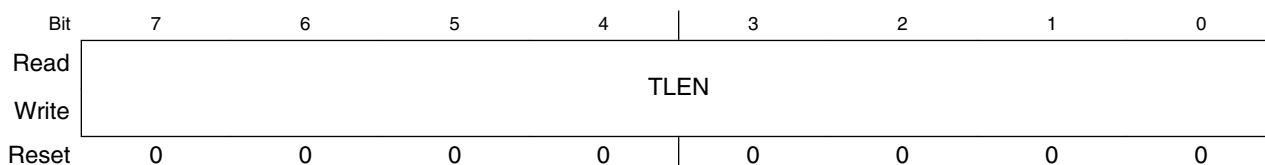

UARTx_TL7816 field descriptions

Field	Description
7-0 TLEN	<p>Transmit Length</p> <p>This value plus 4 indicates the number of characters contained in the block being transmitted. This register is automatically decremented by 1 for each character in the information field portion of the block. Additionally, this register is automatically decremented by 1 for the first character of a CRC in the epilogue field. Hence, this register should be programmed with the number of bytes in the data packet if a LRC is being transmitted, and the number of bytes + 1 if a CRC is being transmitted. This register is not decremented for characters that are assumed to be part of the Prologue field (first three characters transmitted in a block) or the LRC or last CRC character in the Epilogue field (last character transmitted). This field should only be programmed or adjusted when C2[TE] is cleared.</p>

47.4 Functional description

This section provides a complete functional description of the UART block.

The UART allows full duplex, asynchronous, NRZ serial communication between the CPU and remote devices, including other CPUs. The UART transmitter and receiver operate independently, although they use the same baud rate generator. The CPU monitors the status of the UART, writes the data to be transmitted, and processes received data.

47.4.1 Transmitter

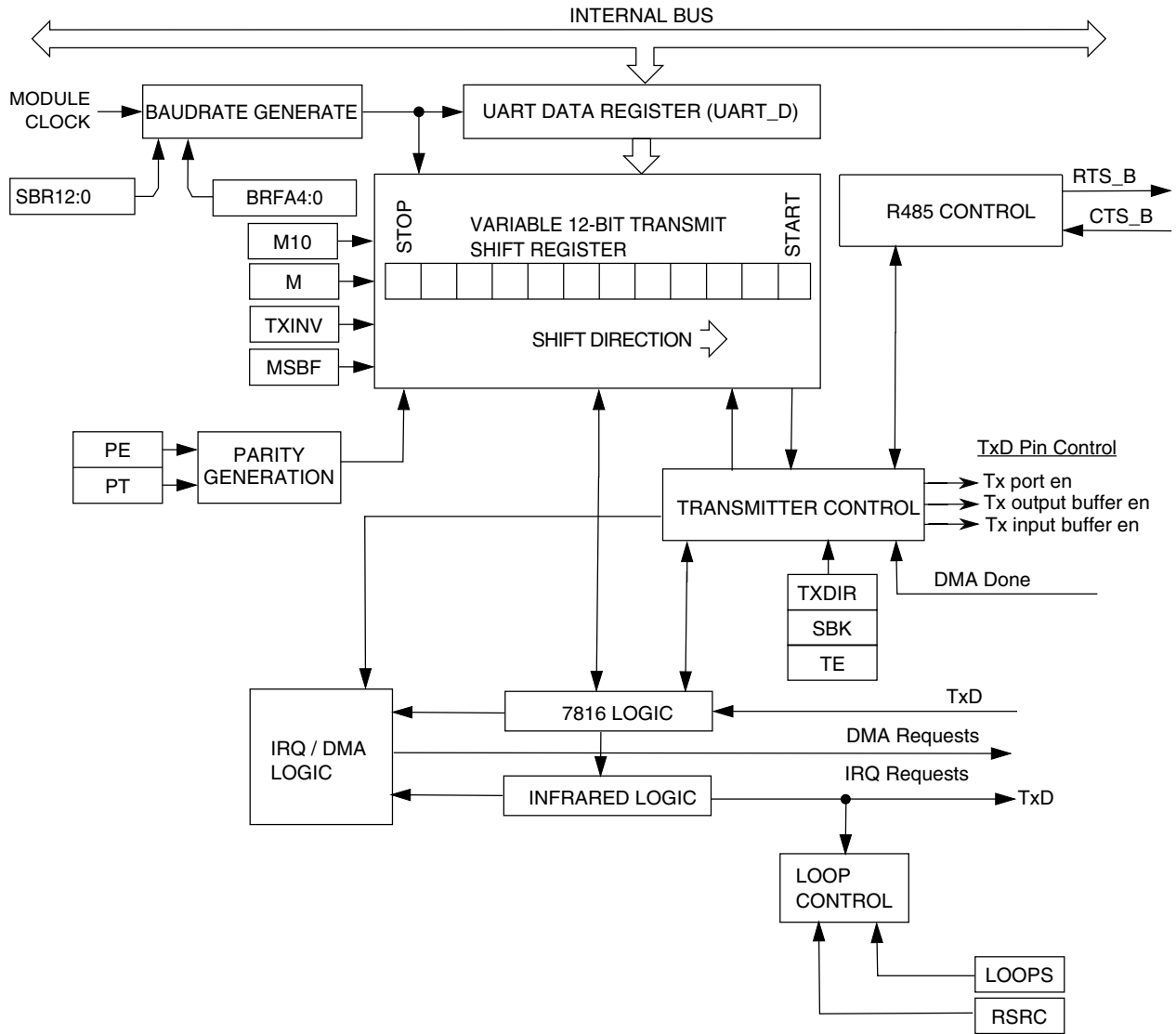

Figure 47-187. Transmitter Block Diagram

47.4.1.1 Transmitter character length

The UART transmitter can accommodate either 8, 9, or 10-bit data characters. The state of the C1[M] and C1[PE] bits and the C4[M10] bit determine the length of data characters. When transmitting 9-bit data, bit C3[T8] is the ninth bit (bit 8).

47.4.1.2 Transmission bit order

When the S2[MSBF] bit is set, the UART automatically transmits the MSB of the data word as the first bit after the start bit. Likewise the LSB of the data word is transmitted immediately preceding the parity bit (or the stop bit if parity is not enabled). All necessary bit ordering is handled automatically by the module hence the format of the data written to the D register for transmission is completely independent of the S2[MSBF] setting.

47.4.1.3 Character transmission

To transmit data, the MCU writes the data bits to the UART transmit buffer using UART data registers (C3[T8]/D). Data in the transmit buffer is then in turn transferred to the transmitter shift register as needed. The transmit shift register then shifts a frame out through the transmit data output signal after it has prefaced it with any required start and stop bits. The UART data registers (C3[T8] and D) provide access to the transmit buffer structure.

The UART also sets a flag, the transmit data register empty flag (S1[TDRE]) and generates interrupt or DMA request (C5[TDMAS]), whenever the number of datawords in the transmit buffer is equal to or less than the value indicated by the TWFIFO[TXWATER]. The transmit driver routine may respond to this flag by writing additional datawords to the transmit buffer using (C3[T8]/D) as space permits.

See [Application information](#) for specific programming sequences.

Setting the C2[TE] bit automatically loads the transmit shift register with a preamble of 10 logic 1s (if C1[M] = 0), 11 logic 1s (if C1[M] = 1 and C4[M10] = 0), or 12 logic 1s (if C1[M] = 1, C4[M10] = 1, C1[PE] = 1). After the preamble shifts out, control logic transfers the data from the UART data register into the transmit shift register. The transmitter automatically transmits the correct start bit and stop bit before and after the dataword.

When C7816[ISO_7816E] = 1 setting the C2[TE] bit does not result in a preamble being generated. The transmitter starts transmitting as soon as the corresponding guard time expires. When C7816[TTYTYPE] = 0 the value in GT is used, when C7816[TTYTYPE] = 1 the value BGT is used since it is assumed that the C2[TE] will remain asserted until the end of the block transfer. The C2[TE] bit is automatically cleared when in C7816[TTYTYPE] = 1 and the block being transmitted has been completed. When C7816[TTYTYPE] = 0, the transmitter listens for a NACK indication. If no NACK is received it is assumed that character was correctly received. If a NACK is received the transmitter will resend the data, assuming that the number of retries for that character (number of NACKs received) is less than or equal to the value in ET7816[TXTHRESHOLD].

Hardware supports odd or even parity. When parity is enabled, the bit immediately preceding the stop bit is the parity bit.

When the transmit shift register is not transmitting a frame, the transmit data output signal goes to the idle condition, logic 1. If at any time software clears the C2[TE] bit, the transmitter enable signal goes low and the transmit signal goes idle.

If software clears C2[TE] while a transmission is in progress, the character in the transmit shift register continues to shift out, provided S1[TC] flag was cleared during the data write sequence. To clear the S1[TC] flag, the S1 register must be read followed by a write to UARTx_D register.

If the S1[TC] flag is cleared during character transmission and the C2[TE] bit is cleared, the transmission enable signal is deasserted at the completion of current frame. Following this, the transmit data out signal enters the idle state even if there is data pending in the UART transmit data buffer. To ensure that all the data written in the FIFO is transmitted on the link before clearing C2[TE], wait for the S1[TC] flag to set. Alternatively, the same can be achieved by setting TWFIFO[TXWATER] to 0x0 and waiting for S1[TDRE] to set.

47.4.1.4 Transmitting break characters

Setting the C2[SBK] loads the transmit shift register with a break character. A break character contains all logic 0s and has no start, stop, or parity bit. Break character length depends on the C1[M] and C1[PE] bits, the S2[BRK13] bit, and the C4[M10] bit. Refer to the following table.

Table 47-195. Transmit break character length

S2[BRK13]	C1[M]	C4[M10]	C1[PE]	Bits transmitted
0	0	—	—	10
0	1	0	—	11
0	1	1	0	11
0	1	1	1	12
1	0	—	—	13
1	1	—	—	14

As long as C2[SBK] is set, transmitter logic continuously loads break characters into the transmit shift register. After software clears the C2[SBK] bit, the shift register finishes transmitting the last break character and then transmits at least one logic 1. The automatic logic 1 at the end of a break character guarantees the recognition of the start bit of the next character. Break bits are not supported when C7816[ISO_7816E] is set/enabled.

NOTE

When queuing a break character, it will be transmitted following the completion of the data value currently being shifted out from the shift register. This means that if data is queued in the data buffer to be transmitted, the break character will preempt that queued data. The queued data will then be transmitted after the break character is complete.

47.4.1.5 Idle characters

An idle character contains all logic 1s and has no start, stop, or parity bit. Idle character length depends on the C1[M] and C1[PE] bits and the C4[M10] bit. The preamble is a synchronizing idle character that begins the first transmission initiated after setting the C2[TE] bit. When C7816[ISO_7816E] is set/enabled, idle characters are not sent or detected. When data is not being transmitted the data I/O line is in an inactive state.

If the C2[TE] bit is cleared during a transmission, the transmit data output signal becomes idle after completion of the transmission in progress. Clearing and then setting the C2[TE] bit during a transmission queues an idle character to be sent after the dataword currently being transmitted.

Note

When queuing an idle character the idle character will be transmitted following the completion of the data value currently being shifted out from the shift register. This means that if data is queued in the data buffer to be transmitted, the idle character will preempt that queued data. The queued data will then be transmitted after the idle character is complete.

If the C2[TE] bit is cleared and the transmission is completed, the UART is not the master of the TXD pin.

47.4.1.6 Hardware flow control

The transmitter supports hardware flow control by gating the transmission with the value of $\overline{\text{CTS}}$. If the clear-to-send operation is enabled, the character is transmitted when $\overline{\text{CTS}}$ is asserted. If $\overline{\text{CTS}}$ is deasserted in the middle of a transmission with characters remaining in the receiver data buffer, the character in the shift register is sent and TXD remains in the mark state until $\overline{\text{CTS}}$ is reasserted.

If the clear-to-send operation is disabled, the transmitter ignores the state of $\overline{\text{CTS}}$. Also, if the transmitter is forced to send a continuous low condition because it is sending a break character, the transmitter ignores the state of $\overline{\text{CTS}}$ regardless of whether the clear-to-send operation is enabled.

The transmitter's $\overline{\text{CTS}}$ signal can also be enabled even if the same UART receiver's $\overline{\text{RTS}}$ signal is disabled.

47.4.1.7 Transceiver driver enable

The transmitter can use $\overline{\text{RTS}}$ as an enable signal for the driver of an external transceiver, see [Transceiver driver enable using \$\overline{\text{RTS}}\$](#) for details. If the request-to-send operation is enabled, when a character is placed into an empty transmitter data buffer, $\overline{\text{RTS}}$ asserts one bit time before the start bit is transmitted. $\overline{\text{RTS}}$ remains asserted for the whole time that the transmitter data buffer has any characters. $\overline{\text{RTS}}$ deasserts one bit time after all characters in the transmitter data buffer and shift register are completely sent, including the last stop bit. Transmitting a break character also asserts $\overline{\text{RTS}}$, with the same assertion and deassertion timing as having a character in the transmitter data buffer.

The transmitter's $\overline{\text{RTS}}$ signal only asserts when the transmitter is enabled. However, the transmitter's $\overline{\text{RTS}}$ signal is unaffected by its $\overline{\text{CTS}}$ signal. $\overline{\text{RTS}}$ will remain asserted until the transfer is completed, even if the transmitter is disabled mid-way through a data transfer.

The following figure shows the functional timing information for the transmitter. Along with the actual character itself, TXD shows the start bit. The stop bit is also indicated, with a dashed line if necessary.

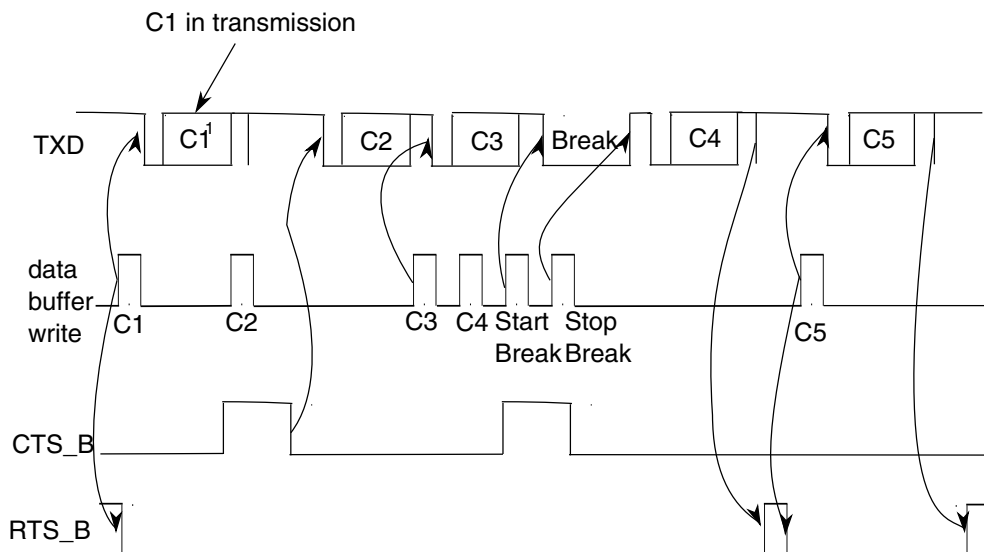

1. Cn = transmit characters

Figure 47-188. Transmitter RTS and CTS timing diagram

47.4.2 Receiver

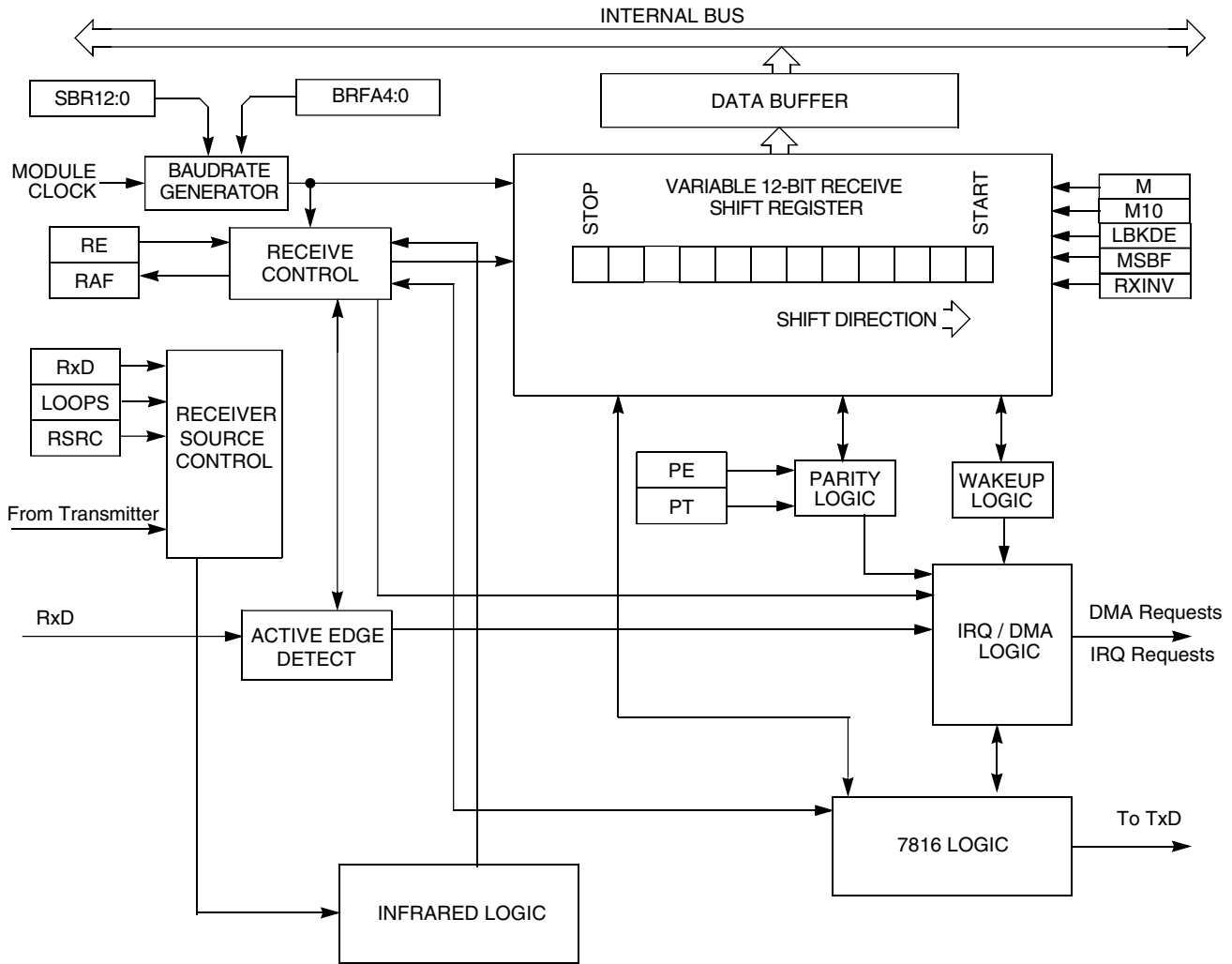

Figure 47-189. UART receiver block diagram

47.4.2.1 Receiver character length

The UART receiver can accommodate 8-, 9-, or 10-bit data characters. The states of the C1[M] and C1[PE] bits and the C4[M10] bit determine the length of data characters. When receiving 9 or 10-bit data, bit C3[R8] is the ninth bit (bit 8).

47.4.2.2 Receiver bit ordering

When the S2[MSBF] bit is set, the receiver operates such that the first bit received after the start bit is the MSB of the data word. Likewise the bit received immediately preceding the parity bit (or the stop bit if parity is not enabled) is treated as the LSB for

the data word. All necessary bit ordering is handled automatically by the module hence the format of the data read from receive data buffer is completely independent of the S2[MSBF] setting.

47.4.2.3 Character reception

During UART reception, the receive shift register shifts a frame in from the unsynchronized receiver input signal. After a complete frame shifts into the receive shift register, the data portion of the frame transfers to the UART receive buffer. Additionally, the noise and parity error flags that are calculated during the receive process are also captured in the UART receive buffer. The receive data buffer is accessible via the D and C3[T8] registers. Additional received information flags regarding the receive dataword can be read in ED register. The S1[RDRF] flag is set if the number of resulting datawords in the receive buffer is equal to or greater than the number indicated by RWFIFO[RXWATER]. If the C2[RIE] is also set, the RDRF flag generates an RDRF interrupt request. Alternatively, by programming the C5[RDMAS] bit correctly a DMA request can be generated.

When 7816E is set/enabled and C7816[TTYPE] = 0, character reception operates slightly differently. Upon receipt of the parity bit, the validity of the parity bit is checked. If C7816[ANACK] is set and the parity check fails or if INIT and the received character is not a valid initial character, then a NACK is sent by the receiver. If the number of consecutive receive errors exceeds the threshold set by ET7816[RXTHRESHOLD] then the IS7816[RXT] flag is set and an interrupt generated if IE7816[RXTE] is set. If an error is detected (parity or invalid initial character) the data is NOT transferred from the receive shift register to the receive buffer. Instead, the data is overwritten by the next incoming data.

When the C7816[ISO_7816E] is set/enabled and C7816[ONACK] is set/enabled and the received character would result in the receive buffer overflowing a NACK is issued by the receiver. Additionally, the S1[OR] flag is set and interrupt issued if appropriate and the data in the shift register is discarded.

47.4.2.4 Data sampling

The receiver samples the unsynchronized receiver input signal at the RT clock rate. The RT clock is an internal signal with a frequency 16 times the baud rate. To adjust for baud rate mismatch, the RT clock (see the following figure) is re-synchronized:

- After every start bit.
- After the receiver detects a data bit change from logic 1 to logic 0 (after the majority of data bit samples at RT8, RT9, and RT10 returns a valid logic 1 and the majority of the next RT8, RT9, and RT10 samples returns a valid logic 0).

To locate the start bit, data recovery logic does an asynchronous search for a logic 0 preceded by three logic 1s. When the falling edge of a possible start bit occurs, the RT clock begins to count to 16.

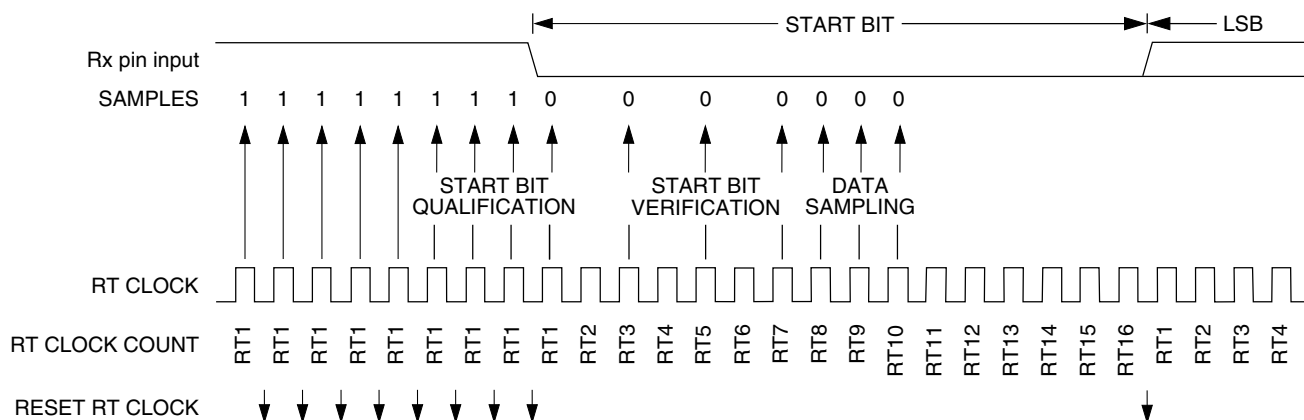

Figure 47-190. Receiver data sampling

To verify the start bit and to detect noise, data recovery logic takes samples at RT3, RT5, and RT7 when C7816[ISO_7816E] is cleared/disabled and RT8, RT9 and RT10 when C7816[ISO_7816E] is set/enabled. The following table summarizes the results of the start bit verification samples.

Table 47-196. Start bit verification

RT3, RT5, and RT7 samples RT8, RT9, RT10 samples when 7816E	Start bit verification	Noise flag
000	Yes	0
001	Yes	1
010	Yes	1
011	No	0
100	Yes	1
101	No	0
110	No	0
111	No	0

If start bit verification is not successful, the RT clock is reset and a new search for a start bit begins.

To determine the value of a data bit and to detect noise, recovery logic takes samples at RT8, RT9, and RT10. The following table summarizes the results of the data bit samples.

Table 47-197. Data bit recovery

RT8, RT9, and RT10 samples	Data bit determination	Noise flag
000	0	0
001	0	1
010	0	1
011	1	1
100	0	1
101	1	1
110	1	1
111	1	0

Note

The RT8, RT9, and RT10 samples do not affect start bit verification. If any or all of the RT8, RT9, and RT10 start bit samples are logic 1s following a successful start bit verification, the noise flag (S1[NF]) is set and the receiver assumes that the bit is a start bit (logic 0). With the exception of when C7816[ISO_7816E] is set/enabled, where the values of RT8, RT9 and RT10 exclusively determine if a start bit exists.

To verify a stop bit and to detect noise, recovery logic takes samples at RT8, RT9, and RT10. The following table summarizes the results of the stop bit samples. In the event that C7816[ISO_7816E] is set/enabled and C7816[TTYTYPE] = 0, verification of a stop bit does not take place. Rather, starting with RT8 the receiver transmits a NACK as programmed until time RT9 of the following time period. Framing Error detection is not supported when C7816[ISO_7816E] is set/enabled.

Table 47-198. Stop bit recovery

RT8, RT9, and RT10 samples	Framing error flag	Noise flag
000	1	0
001	1	1
010	1	1
011	0	1
100	1	1
101	0	1
110	0	1
111	0	0

In the following figure, the verification samples RT3 and RT5 determine that the first low detected was noise and not the beginning of a start bit. In this example $C7816[ISO_7816E] = 0$. The RT clock is reset and the start bit search begins again. The noise flag is not set because the noise occurred before the start bit was found.

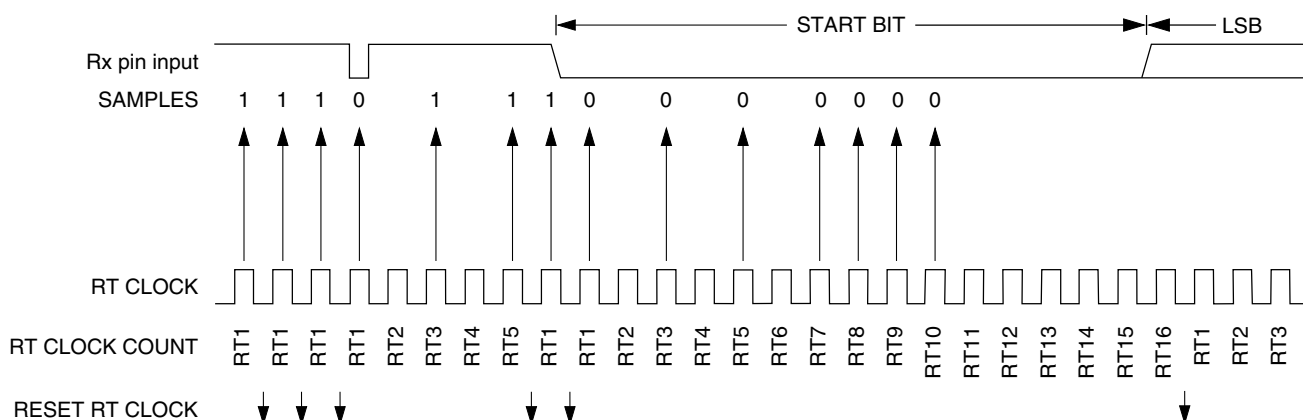

Figure 47-191. Start bit search example 1 ($C7816[ISO_7816E] = 0$)

In the following figure, verification sample at RT3 is high. In this example $C7816[ISO_7816E] = 0$. The RT3 sample sets the noise flag. Although the perceived bit time is misaligned, the data samples RT8, RT9, and RT10 are within the bit time and data recovery is successful.

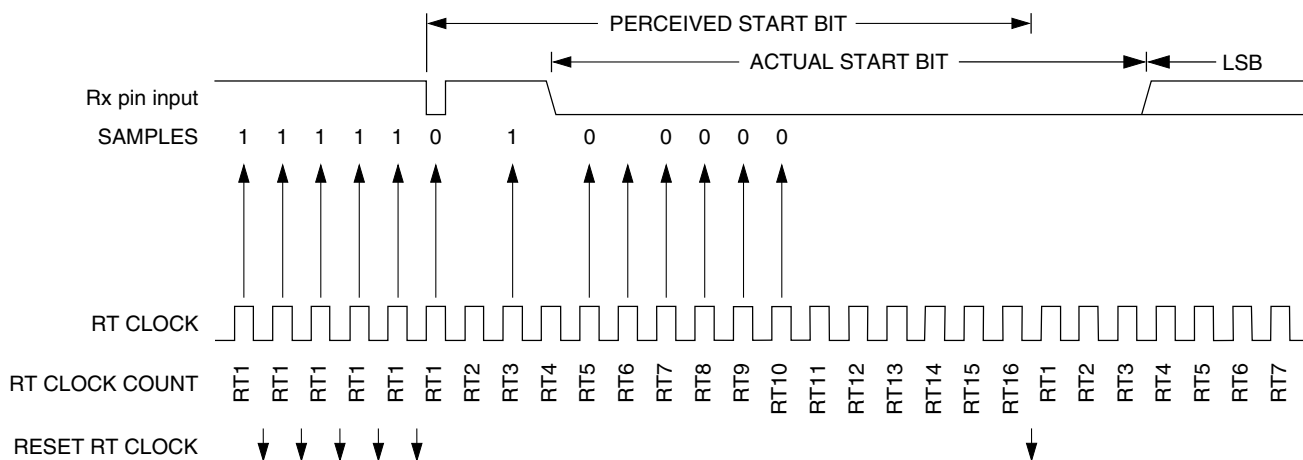

Figure 47-192. Start bit search example 2 ($C7816[ISO_7816E] = 0$)

In the following figure, a large burst of noise is perceived as the beginning of a start bit, although the test sample at RT5 is high. In this example $C7816[ISO_7816E] = 0$. The RT5 sample sets the noise flag. Although this is a worst-case misalignment of perceived bit time, the data samples RT8, RT9, and RT10 are within the bit time and data recovery is successful.

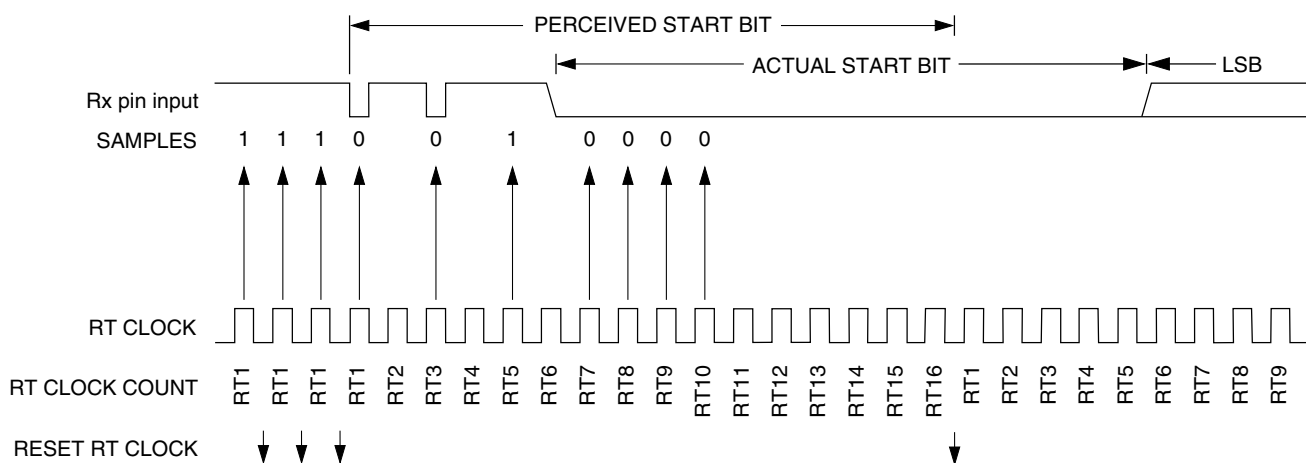

Figure 47-193. Start bit search example 3 (C7816[ISO_7816E] = 0)

The following figure shows the effect of noise early in the start bit time. In this example C7816[ISO_7816E] = 0. Although this noise does not affect proper synchronization with the start bit time, it does set the noise flag.

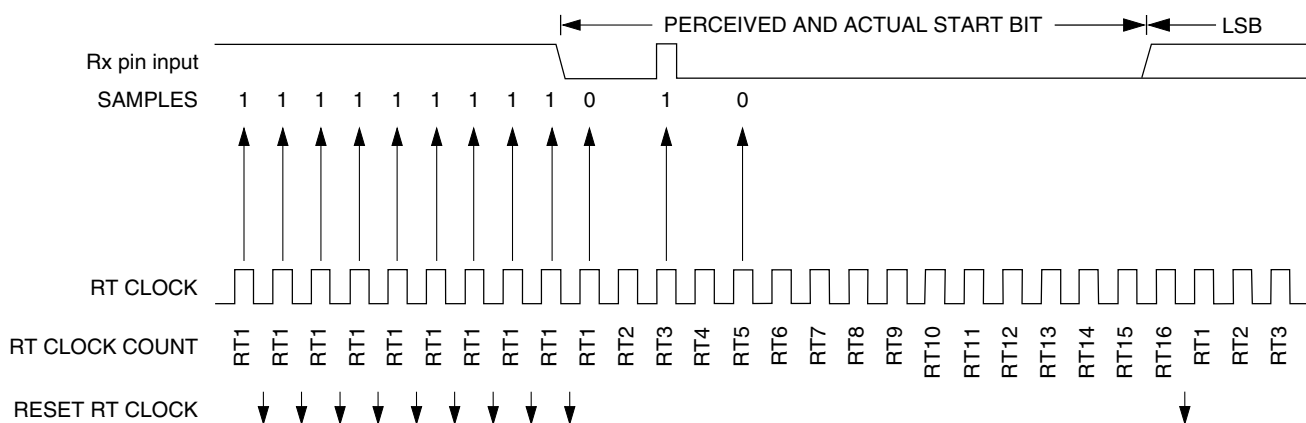

Figure 47-194. Start bit search example 4 (C7816[ISO_7816E] = 0)

The following figure shows a burst of noise near the beginning of the start bit that resets the RT clock. In this example C7816[ISO_7816E] = 0. The sample after the reset is low but is not preceded by three high samples that would qualify as a falling edge. Depending on the timing of the start bit search and on the data, the frame may be missed entirely or it may set the framing error flag.

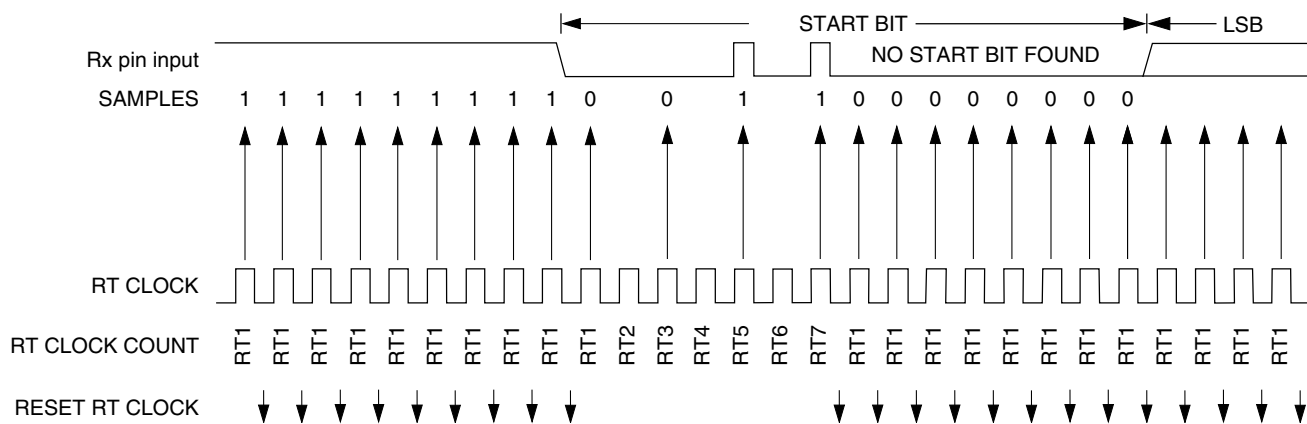

Figure 47-195. Start bit search example 5 (C7816[ISO_7816E] = 0)

In the following figure, a noise burst makes the majority of data samples RT8, RT9, and RT10 high. In this example C7816[ISO_7816E] = 0. This sets the noise flag but does not reset the RT clock. In start bits only, the RT8, RT9, and RT10 data samples are ignored. In this example, if C7816[ISO_7816E] = 1 then a start bit would not have been detected at all since at least two of the three samples (RT8, RT9, RT10) were high.

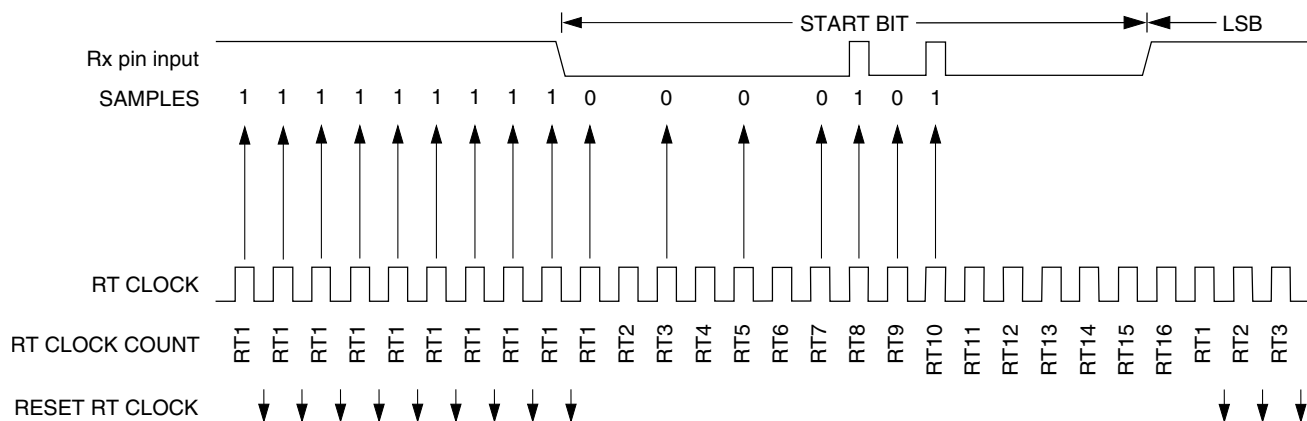

Figure 47-196. Start bit search example 6

47.4.2.5 Framing errors

If the data recovery logic does not detect a logic 1 where the stop bit should be in an incoming frame, it sets the framing error flag, S1[FE] if S2[LBKDE] is disabled. A break character when S2[LBKDE] is disabled also sets the S1[FE] because a break character has no stop bit. The S1[FE] is set at the same time that received data is placed in the receive data buffer. Framing errors are not supported when C7816[ISO7816E] is set/enabled. However, if the S1[FE] is set data will not be received when C7816[ISO7816E] is set.

47.4.2.6 Receiving break characters

The UART recognizes a break character when a start bit is followed by eight, nine, or ten logic 0 data bits and a logic 0 where the stop bit should be. Receiving a break character has these effects on UART registers:

- Sets the framing error flag, S1[FE].
- Writes an all "0" dataword to the data buffer, which may cause S1[RDRF] to set depending on the watermark and number of values in the data buffer.
- May set the overrun flag, S1[OR], noise flag, S1[NF], parity error flag, S1[PE], or the receiver active flag, S2[RAF].

The detection threshold for a break character can be adjusted when using an internal oscillator in a LIN system by setting the S2[LBKDE] bit. The UART break character detection threshold depends on the C1[M] and C1[PE] bits, the C4[LBKDE] bit, and the C4[M10] bit. Refer to the following table.

Table 47-199. Receive break character detection threshold

LBKDE	M	M10	PE	Threshold (bits)
0	0	—	—	10
0	1	0	—	11
0	1	1	0	11
0	1	1	1	12
1	0	—	—	11
1	1	—	—	12

While C4[LBKDE] is set, it will have these effects on the UART registers:

- Prevents the S1[RDRF], S1[FE], S1[NF], and S1[PF] flags from being set. However, if they are already set they will remain set.
- Sets the LIN break detect interrupt flag, S2[LBKDIF] if a LIN break character is received.

Break characters are not detected or supported when C7816[ISO_7816E] is set/enabled.

47.4.2.7 Hardware flow control

To support hardware flow control, the receiver can be programmed to automatically deassert and assert $\overline{\text{RTS}}$.

- $\overline{\text{RTS}}$ will remain asserted until the transfer is completed, even if the transmitter is disabled mid way through a data transfer, see [Transceiver driver enable using \$\overline{\text{RTS}}\$](#) for more details.
- If the receiver request-to-send functionality is enabled, the receiver automatically deasserts $\overline{\text{RTS}}$ if the number of characters in the receiver data register is equal to or greater than receiver data buffer's watermark, `RWFIFO[RXWATER]`.
- The receiver asserts $\overline{\text{RTS}}$ when the number of characters in the receiver data register is less than the watermark. It is not affected by whether RDRF is asserted.
- Even if $\overline{\text{RTS}}$ is deasserted, the receiver continues to receive characters until the receiver data buffer is full or is overrun.
- If the receiver request-to-send functionality is disabled, the receiver $\overline{\text{RTS}}$ remains deasserted.

The following figure shows receiver hardware flow control functional timing. Along with the actual character itself, RXD shows the start bit. The stop bit also indicated, with a dashed line if necessary. The watermark is set to 2.

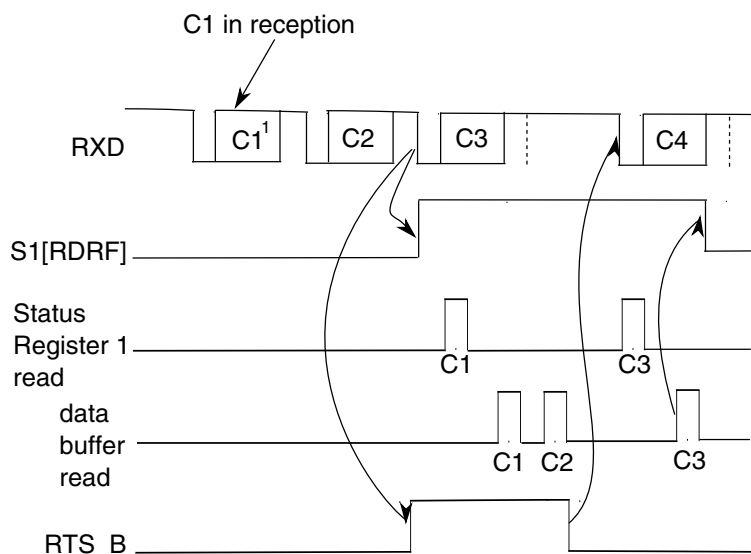

Figure 47-197. Receiver hardware flow control timing diagram

47.4.2.8 Infrared decoder

The infrared decoder converts the received character from the IrDA format to the NRZ format used by the receiver. It also has a 16-RT clock counter that filters noise and indicates when a '1' is being received.

47.4.2.8.1 Start bit detection

When S2[RXINV] is cleared, the first rising edge of the received character corresponds to the start bit. The infrared decoder resets its counter. At this time, the receiver also begins its start bit detection process. Once the start bit is detected, the receiver synchronizes its bit times to this start bit time. For the rest of the character reception, the infrared decoder's counter and the receiver's bit time counter count independently from each other.

47.4.2.8.2 Noise filtering

Any further rising edges detected during the first half of the infrared decoder counter are ignored by the decoder. Any pulses less than one RT clocks can be undetected by it regardless of whether it is seen in the first or second half of the count.

47.4.2.8.3 Low-bit detection

During the second half of the decoder count, a rising edge is decoded as a '0', which is sent to the receiver. The decoder counter also is reset.

47.4.2.8.4 High-bit detection

At 16-RT clocks after the previous rising edge, if a rising edge is not seen, then the decoder sends a '1' to the receiver.

If the next bit is a '0' which arrives late, then a low-bit is detected according to [Low-bit detection](#). The value sent to the receiver is changed from '1' to a '0'. Then if a noise pulse occurs outside of the receiver's bit time sampling period, then the delay of a '0' is not recorded as noise.

47.4.2.9 Baud rate tolerance

A transmitting device may be operating at a baud rate below or above the receiver baud rate. Accumulated bit time misalignment can cause one of the three stop bit data samples (RT8, RT9, and RT10) to fall outside the actual stop bit. A noise error will occur if the RT8, RT9, and RT10 samples are not all the same logical values. A framing error will occur if the receiver clock is misaligned in such a way that the majority of the RT8, RT9, and RT10 stop bit samples are a logic zero.

As the receiver samples an incoming frame, it re-synchronizes the RT clock on any valid falling edge within the frame. Resynchronization within frames will correct a misalignment between transmitter bit times and receiver bit times.

47.4.2.9.1 Slow data tolerance

The following figure shows how much a slow received frame can be misaligned without causing a noise error or a framing error. The slow stop bit begins at RT8 instead of RT1 but arrives in time for the stop bit data samples at RT8, RT9, and RT10.

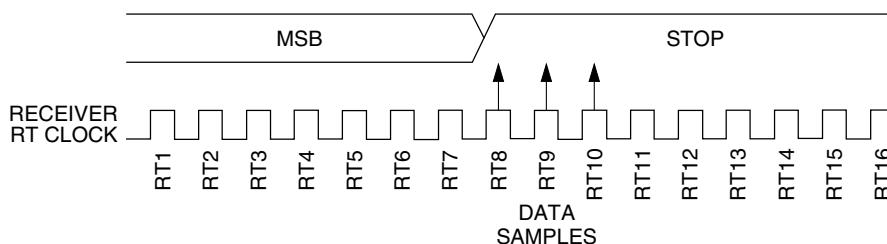

Figure 47-198. Slow data

For an 8-bit data character, data sampling of the stop bit takes the receiver 154 RT cycles (9 bit times × 16 RT cycles + 10 RT cycles).

With the misaligned character shown in the above figure, the receiver counts 154 RT cycles at the point when the count of the transmitting device is 147 RT cycles (9 bit times × 16 RT cycles + 3 RT cycles).

The maximum percent difference between the receiver count and the transmitter count of a slow 8-bit data character with no errors is:

$$((154 - 147) \div 154) \times 100 = 4.54\%$$

For a 9-bit data character, data sampling of the stop bit takes the receiver 170 RT cycles (10 bit times × 16 RT cycles + 10 RT cycles).

With the misaligned character shown in the above figure, the receiver counts 170 RT cycles at the point when the count of the transmitting device is 163 RT cycles (10 bit times × 16 RT cycles + 3 RT cycles).

The maximum percent difference between the receiver count and the transmitter count of a slow 9-bit character with no errors is:

$$((170 - 163) \div 170) \times 100 = 4.12\%$$

47.4.2.9.2 Fast data tolerance

The following figure shows how much a fast received frame can be misaligned. The fast stop bit ends at RT10 instead of RT16 but is still sampled at RT8, RT9, and RT10.

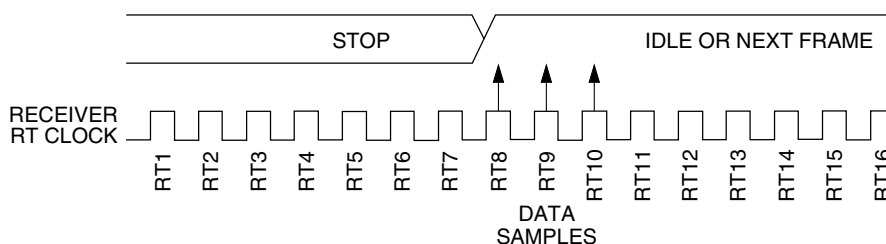

Figure 47-199. Fast data

For an 8-bit data character, data sampling of the stop bit takes the receiver 154 RT cycles (9 bit times \times 16 RT cycles + 10 RT cycles).

With the misaligned character shown in the above figure, the receiver counts 154 RT cycles at the point when the count of the transmitting device is 160 RT cycles (10 bit times \times 16 RT cycles).

The maximum percent difference between the receiver count and the transmitter count of a fast 8-bit character with no errors is:

$$((154 - 160) \div 154) \times 100 = 3.90\%$$

For a 9-bit data character, data sampling of the stop bit takes the receiver 170 RT cycles (10 bit times \times 16 RT cycles + 10 RT cycles).

With the misaligned character shown in the above figure, the receiver counts 170 RT cycles at the point when the count of the transmitting device is 176 RT cycles (11 bit times \times 16 RT cycles).

The maximum percent difference between the receiver count and the transmitter count of a fast 9-bit character with no errors is:

$$((170 - 176) \div 170) \times 100 = 3.53\%$$

47.4.2.10 Receiver wakeup

The C1[WAKE] bit determines how the UART is brought out of the standby state to process an incoming message. The C1[WAKE] bit enables either idle line wakeup or address mark wakeup.

Receiver wakeup is not supported when C7816[ISO_7816E] is set/enabled since multi-receiver systems are not allowed.

47.4.2.10.1 Idle input line wakeup (C1[WAKE] = 0)

In this wakeup method, an idle condition on the unsynchronized receiver input signal clears the C2[RWU] bit and wakes the UART. The initial frame or frames of every message contain addressing information. All receivers evaluate the addressing information, and receivers for which the message is addressed process the frames that follow. Any receiver for which a message is not addressed can set its C2[RWU] bit and return to the standby state. The C2[RWU] bit remains set and the receiver remains in standby until another idle character appears on the unsynchronized receiver input signal.

Idle line wakeup requires that messages be separated by at least one idle character and that no message contains idle characters.

When C2[RWU] is one and S2[RWUID] is zero, the idle character that wakes the receiver does not set the S1[IDLE] flag or the receive data register full flag, S1[RDRF]. The receiver wakes and waits for the first data character of the next message which will be stored in the receive data buffer. When S2[RWUID] and C2[RWU] bits are set and C1[WAKE] is cleared, any idle condition sets the S1[IDLE] flag and generates an interrupt if enabled.

Idle Input Line Wakeup is not supported when C7816[ISO_7816E] is set/enabled.

47.4.2.10.2 Address mark wakeup (C1[WAKE] = 1)

In this wakeup method, a logic 1 in the bit position immediately preceding the stop bit of a frame clears the C2[RWU] bit and wakes the UART. A logic 1 in the bit position immediately preceding the stop bit marks a frame as an address frame that contains addressing information. All receivers evaluate the addressing information, and the receivers for which the message is addressed process the frames that follow. Any receiver for which a message is not addressed can set its C2[RWU] bit and return to the standby state. The C2[RWU] bit remains set and the receiver remains in standby until another address frame appears on the unsynchronized receiver input signal.

A logic 1 in the bit position immediately preceding the stop bit clears the receiver's C2[RWU] bit before the stop bit is received and places the received data into the receiver data buffer.

Address mark wakeup allows messages to contain idle characters but requires that the bit position immediately preceding the stop bit be reserved for use in address frames.

If module is in standby mode and nothing triggers to wake the UART, no error flag is set even if an invalid error condition is detected on the receiving data line.

Address mark wakeup is not supported when C7816[ISO_7816E] is set/enabled.

47.4.2.10.3 Match address operation

Match address operation is enabled when the C4[MAEN1] or C4[MAEN2] bit is set. In this function, a frame received by the RX pin with a logic 1 in the bit position immediately preceding the stop bit is considered an address and is compared with the associated MA1 or MA2 register. The frame is only transferred to the receive buffer, and S1[RDRF] is set, if the comparison matches. All subsequent frames received with a logic 0 in the bit position immediately preceding the stop bit are considered to be data associated with the address and are transferred to the receive data buffer. If no marked address match occurs then no transfer is made to the receive data buffer, and all following frames with logic zero in the bit position immediately preceding the stop bit are also discarded. If both the C4[MAEN1] and C4[MAEN2] bits are negated, the receiver operates normally and all data received is transferred to the receive data buffer.

Match Address operation functions in the same way for both MA1 and MA2 registers.

- If only one of C4[MAEN1] and C4[MAEN2] is asserted, a marked address is compared only with the associated match register and data is transferred to the receive data buffer only on a match.
- If C4[MAEN1] and C4[MAEN2] are asserted, a marked address is compared with both match registers and data is transferred only on a match with either register.

Address match operation is not supported when C7816[ISO_7816E] is set/enabled.

47.4.3 Baud rate generation

A 13-bit modulus counter and a 5-bit fractional fine-adjust counter in the baud rate generator derive the baud rate for both the receiver and the transmitter. The value from 1 to 8191 written to the SBR[12:0] bits determines the module clock divisor. The SBR bits are in the UART baud rate registers (BDH and BDL). The baud rate clock is synchronized with the module clock and drives the receiver. The fractional fine-adjust counter adds fractional delays to the baud rate clock to allow fine trimming of the baud rate to match the system baud rate. The baud rate clock divided by 16 drives the transmitter. The receiver has an acquisition rate of 16 samples per bit time.

Baud rate generation is subject to two sources of error:

- Integer division of the module clock may not give the exact target frequency. This error can be reduced by means of the fine-adjust counter.
- Synchronization with the module clock can cause phase shift.

The [Table 47-200](#) lists the available baud divisor fine adjust values.

$$\text{UART baud rate} = \text{UART module clock} / (16 \times (\text{SBR}[12:0] + \text{BRFD}))$$

The following table lists some examples of achieving target baud rates with a module clock frequency of 10.2 MHz, with and without fractional fine adjustment.

Table 47-200. Baud rates (example: module clock = 10.2 MHz)

Bits SBR (decimal)	Bits BRFA	BRFD value	Receiver clock (Hz)	Transmitter clock (Hz)	Target Baud rate	Error (%)
17	00000	0	600,000.0	37,500.0	38,400	2.3
16	10011	19/32=0.59375	614,689.3	38,418.08	38,400	0.047
33	00000	0	309,090.9	19,318.2	19,200	0.62
33	00110	6/32=0.1875	307,344.6	19,209.04	19,200	0.047
66	00000	0	154,545.5	9659.1	9600	0.62
133	00000	0	76,691.7	4793.2	4800	0.14
266	00000	0	38,345.9	2396.6	2400	0.14
531	00000	0	19,209.0	1200.6	1200	0.11
1062	00000	0	9604.5	600.3	600	0.05
2125	00000	0	4800.0	300.0	300	0.00
4250	00000	0	2400.0	150.0	150	0.00
5795	00000	0	1760.1	110.0	110	0.00

Table 47-201. Baud rate fine adjust

BRFA	Baud Rate Fractional Divisor (BRFD)
0 0 0 0 0	0/32 = 0
0 0 0 0 1	1/32 = 0.03125
0 0 0 1 0	2/32 = 0.0625
0 0 0 1 1	3/32 = 0.09375
0 0 1 0 0	4/32 = 0.125
0 0 1 0 1	5/32 = 0.15625
0 0 1 1 0	6/32 = 0.1875
0 0 1 1 1	7/32 = 0.21875
0 1 0 0 0	8/32 = 0.25
0 1 0 0 1	9/32 = 0.28125
0 1 0 1 0	10/32 = 0.3125
0 1 0 1 1	11/32 = 0.34375
0 1 1 0 0	12/32 = 0.375

Table continues on the next page...

Table 47-201. Baud rate fine adjust (continued)

BRFA	Baud Rate Fractional Divisor (BRFD)
0 1 1 0 1	13/32 = 0.40625
0 1 1 1 0	14/32 = 0.4375
0 1 1 1 1	15/32 = 0.46875
1 0 0 0 0	16/32 = 0.5
1 0 0 0 1	17/32 = 0.53125
1 0 0 1 0	18/32 = 0.5625
1 0 0 1 1	19/32 = 0.59375
1 0 1 0 0	20/32 = 0.625
1 0 1 0 1	21/32 = 0.65625
1 0 1 1 0	22/32 = 0.6875
1 0 1 1 1	23/32 = 0.71875
1 1 0 0 0	24/32 = 0.75
1 1 0 0 1	25/32 = 0.78125
1 1 0 1 0	26/32 = 0.8125
1 1 0 1 1	27/32 = 0.84375
1 1 1 0 0	28/32 = 0.875
1 1 1 0 1	29/32 = 0.90625
1 1 1 1 0	30/32 = 0.9375
1 1 1 1 1	31/32 = 0.96875

47.4.4 Data format (non ISO-7816)

Each data character is contained in a frame that includes a start bit and a stop bit. The rest of the data format depends upon UARTx_C1[M], UARTx_C1[PE], UARTx_S2[MSBF], and UARTx_C4[M10].

47.4.4.1 Eight-bit configuration

Clearing the UART_C1[M] configures the UART for 8-bit data characters, that is, eight bits are memory mapped in UART_D. A frame with eight data bits has a total of 10 bits. The most significant bit of the eight data bits can be used as an address mark to wake the receiver. If that bit is used in this way, then it serves as an address or data indication, leaving the remaining seven bits as actual data. When UART_C1[PE] is set, the 8th databit is automatically calculated as the parity bit. Refer to the following table.

Table 47-202. Configuration of 8-bit data format

UART_C1[PE]	Start bit	Data bits	Address bits	Parity bits	Stop bit
0	1	8	0	0	1
0	1	7	1 ¹	0	1
1	1	7	0	1	1

1. The address bit identifies the frame as an address character. See [Receiver wakeup](#).

47.4.4.2 Nine-bit configuration

When UARTx_C1[M] is set and UARTx_C4[M10] is cleared the UART is configured for 9-bit data characters. The 9th bit is either UARTx_C3[T8/R8] or the internally generated parity bit if UARTx_C1[PE] is enabled. This results in a frame consisting of a total of 11 bits. In the event that the 9th data bit is selected to be UARTx_C3[T8] it will remain unchanged after transmission and can be used repeatedly without rewriting it unless the value needs to be changed. This feature may be useful when the 9th data bit is being used as an address mark.

When UARTx_C1[M] is set and UARTx_C4[M10] is set the UART is configured for 9-bit data characters, but the frame consists of a total of 12 bits. The 12 bits include the start and stop bits, the 9 data character bits and a 10th internal data bit. Note that if UARTx_C4[M10] is set UARTx_C1[PE] must also be set. In this case, the 10th bit is the internally generated parity bit. The 9th bit is can either be used as a address mark or a 9th data bit.

Refer to the following table.

Table 47-203. Configuration of 9-bit data formats

C1[PE]	UC1[M]	C1[M10]	Start bit	Data bits	Address bits	Parity bits	Stop bit
0	0	0	See Eight-bit configuration				
0	0	1	Invalid configuration				
0	1	0	1	9	0	0	1
0	1	0	1	8	1 ¹	0	1
0	1	1	Invalid Configuration				
1	0	0	See Eight-bit configuration				
1	0	1	Invalid Configuration				
1	1	0	1	8	0	1	1
1	1	1	1	9	0	1	1
1	1	1	1	8	1 ²	1	1

1. The address bit identifies the frame as an address character.
2. The address bit identifies the frame as an address character.

Note

Unless in 9-bit mode with M10 set, do not use address mark wakeup with parity enabled.

47.4.4.3 Timing examples

Timing examples of these configurations in the NRZ mark/space data format are illustrated in the following figures. The timing examples show all of the configurations in the following sub-sections along with the LSB and MSB first variations.

47.4.4.3.1 Eight-bit format with parity disabled

The most significant bit can be used for address mark wakeup.



Figure 47-200. Eight bits of data with LSB first

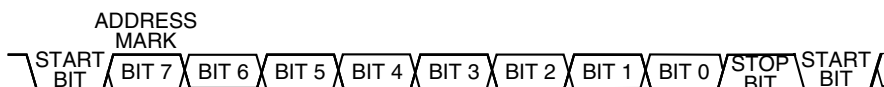

Figure 47-201. Eight bits of data with MSB first

47.4.4.3.2 Eight-bit format with parity enabled



Figure 47-202. Seven bits of data with LSB first and parity



Figure 47-203. Seven bits of data with MSB first and parity

47.4.4.3.3 Nine-bit format with parity disabled

The most significant bit can be used for address mark wakeup.

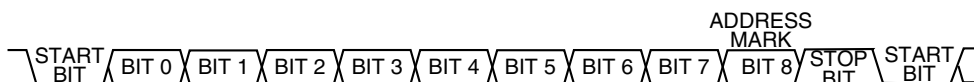

Figure 47-204. Nine bits of data with LSB first



Figure 47-205. Nine bits of data with MSB first

47.4.4.3.4 Nine-bit format with parity enabled

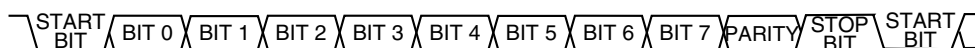

Figure 47-206. Eight bits of data with LSB first and parity

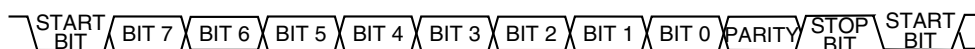

Figure 47-207. Eight bits of data with MSB first and parity

47.4.4.3.5 Non-memory mapped tenth bit for parity

The most significant memory-mapped bit can be used for address mark wakeup.

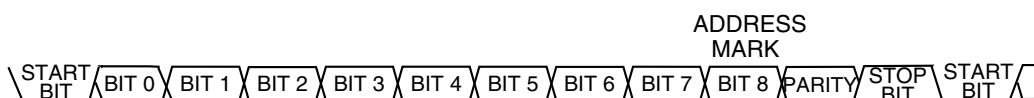

Figure 47-208. Nine bits of data with LSB first and parity



Figure 47-209. Nine bits of data with MSB first and parity

47.4.5 Single-wire operation

Normally, the UART uses two pins for transmitting and receiving. In single-wire operation, the RXD pin is disconnected from the UART and the UART implements a half-duplex serial connection. The UART uses the TXD pin for both receiving and transmitting.

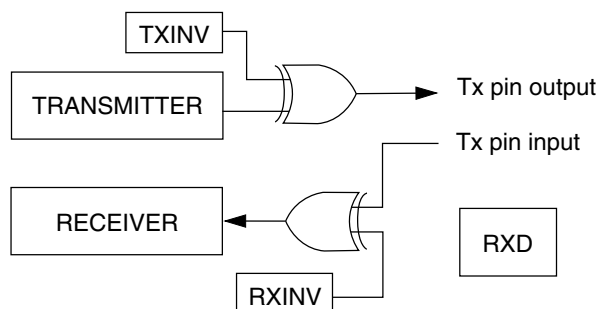

Figure 47-210. Single-wire operation (C1[LOOPS] = 1, C1[RSRC] = 1)

Enable single-wire operation by setting the C1[LOOPS] bit and the receiver source bit, C1[RSRC]. Setting the C1[LOOPS] bit disables the path from the unsynchronized receiver input signal to the receiver. Setting the C1[RSRC] bit connects the receiver input to the output of the TXD pin driver. Both the transmitter and receiver must be enabled (C2[TE] = 1 and C2[RE] = 1). When C7816[ISO_7816EN] is set, it is not a requirement that both C2[TE] and C2[RE] are set.

47.4.6 Loop operation

In loop operation the transmitter output goes to the receiver input. The unsynchronized receiver input signal is disconnected from the UART.

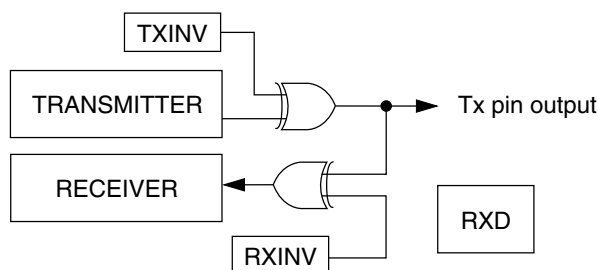

Figure 47-211. Loop operation (C1[LOOPS] = 1, C1[RSRC] = 0)

Enable loop operation by setting the C1[LOOPS] bit and clearing the C1[RSRC] bit. Setting the C1[LOOPS] bit disables the path from the unsynchronized receiver input signal to the receiver. Clearing the C1[RSRC] bit connects the transmitter output to the receiver input. Both the transmitter and receiver must be enabled (C2[TE] = 1 and C2[RE] = 1). When C7816[ISO_7816EN] is set, it is not a requirement that both C2[TE] and C2[RE] are set.

47.4.7 ISO-7816 / smartcard support

The UART provides mechanisms to support the ISO-7816 protocol that is commonly used to interface with smartcards. The ISO-7816 protocol is an NRZ, single wire, half-duplex interface. The TxD pin is used in open-drain mode since the data signal is used for both transmitting and receiving. There are multiple subprotocols within the ISO-7816 standard. The UART supports both T = 0 and T = 1 protocols. The module also provides for automated initial character detection and configuration which allows for support of both direct convention and inverse convention data formats. A variety of interrupts specific to 7816 are provided in addition to the general interrupts to assist software.

Additionally the module is able to provide automated NACK responses and has programming automated retransmission of failed packets. An assortment of programmable timeouts and guard band times are also supported.

The term elemental time unit (ETU) is frequently used in the context of ISO-7816. This concept is used to relate the frequency that the system (UART) is running at and the frequency that data is being transmitted and received. One ETU represents the time it takes to transmit or receive a single bit. For example, a standard 7816 packet, excluding any guard time or NACK elements is 10 ETUs (start bit, 8 data bits and a parity bit). Guard times and wait times are also measured in ETUs.

NOTE

The ISO-7816 specification may have certain configuration options that are reserved. In order to maintain maximum flexibility to support future 7816 enhancements or devices which may not strictly conform to the specification, the UART does not prevent those options being used. Further, the UART may provide configuration options that exceed the flexibility of options explicitly allowed by the 7816 specification. Failure to correctly configure the UART may result in unexpected behavior or incompatibility with the ISO-7816 specification.

47.4.7.1 Initial characters

In ISO-7816 mode, the UART can be configured to use the C7816[INIT] bit to detect the next valid initial character, referred to by the ISO-7816 specifically as a TS character. When the initial character is detected, the UART provides the host processor with an interrupt if IE7816[INITDE] is set. Additionally, the UART will set the S2[MSBF], C3[TXINV] and S2[RXINV] register fields automatically based on the initial character. The corresponding initial character and resulting register settings are listed in the following table.

Table 47-204. Initial character automated settings

Initial character (bit 1-10)	Initial character (hex)	MSBF	TXINV	RXINV
LHHL LLL LLH inverse convention	3F	1	1	1
LHHL HHH LLH direct convention	3B	0	0	0

When the C7816[INIT] bit is set, the receiver will search all received data for the first valid initial character. All data received which is not a valid initial character will be ignored and all flags resulting from the invalid data will be blocked from asserting. If the C7816[ANACK] bit is set, a NACK will be returned for invalid received initial characters and a RXT interrupt will be generated as programmed.

47.4.7.2 Protocol T = 0

When T = 0 protocol is selected, a relatively complex error detection scheme is used. Data characters are formatted as illustrated in the following figure. This scheme is also used for answer to reset and PPS formats.

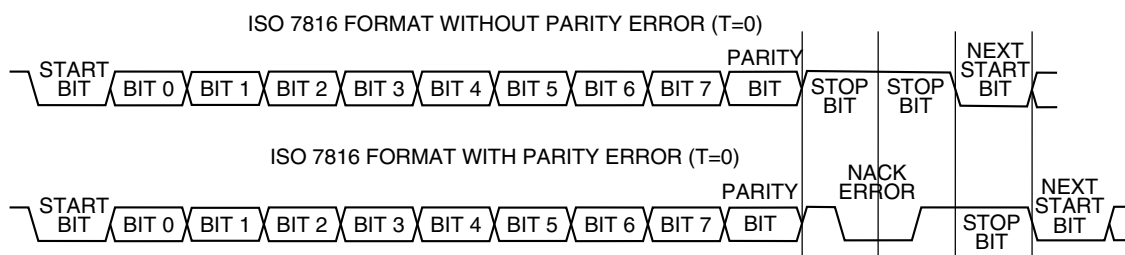

Figure 47-212. ISO-7816 T = 0 data format

As with other protocols supported by the UART the data character includes a start bit. However, in this case there are two stop bits rather than the typical single stop bit. In addition to a standard even parity check, the receiver has the ability to generate and return a NACK during the second half of the first stop bit period. The NACK must be at least one time period (ETU) in length and no more than 2 time periods (ETU) in length. The transmitter must wait for at least two time units (ETU) after detection of the error signal before attempting to retransmit the character.

It is assumed that the UART and the device (smartcard) know in advance which device is receiving and which is transmitting. No special mechanism is supplied by the UART to control receive and transmit in the mode other than the C2[TE] and C2[RE] bits.

47.4.7.3 Protocol T = 1

When T = 1 protocol is selected the NACK error detection scheme is not used. Rather, the parity bit is used on a character basis and a CRC or LRC is used on the block basis (i.e. each group of characters). As such, in this mode the data format allows for a single stop bit although additional inactive bit periods may be present between the stop bit and the next start bit. Data characters are formatted as illustrated in the following figure.

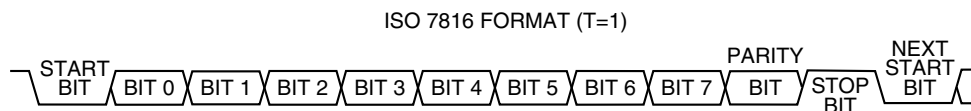

Figure 47-213. ISO 7816 T=1 data format

The smallest data unit that is transferred is a block. A block is made up of several data characters and may vary in size depending on the block type. The UART does not provide a mechanism to decode the block type. As part of the block, an LRC or CRC is included. The UART does not calculate the CRC or LRC for transmitted blocks nor does it verify the validity of the CRC or LRC for received blocks. The 7816 protocol requires that the initiator and the smartcard (device) takes alternate turns in transmitting and receiving blocks. When the UART detects that the last character in a block has been transmitted it will automatically clear the C2[TE] bit and enter receive mode. Hence, software must program the transmit buffer with the next data to be transmitted and then enable the C2[TE] bit once software has determined that the last character of the received block has been received. The UART detects that the last character of the transmit block has been sent when TL7816[TLEN] = 0 and four additional characters have been sent. The four additional characters are made up of three prior to TL7816[TLEN] decrementing (prologue) and one after TL7816[TLEN] = 0, the final character of the epilogue.

47.4.7.4 Wait time and guard time parameters

The ISO-7816 specification defines several wait time and guard time parameters. The UART allows for flexible configuration and violation detection of these settings. On reset the wait time (IS7816[WT]) defaults to 9600 ETUs and guard time (GT) to 12 ETUs. These values are controlled by parameters in the WP7816, WN7816 and WF7816 registers. Additionally the value of C7816[TTYTYPE] also factors into the calculation. The formulas used to calculate the number ETU for each wait time and guard time value are shown in the following table.

Wait time (WT) is defined as the maximum allowable time between the leading edge of a character transmitted by the device (smartcard) and the leading edge of the previous character that was transmitted by the UART or the device. Likewise character wait time (CWT) is defined as the maximum allowable time between the leading edge of two characters within the same block, and block wait time (BWT) is defined as the maximum time between the leading edge character of the last block received by the device/smartcard and the leading edge of the first character transmitted by the device/smartcard.

Guard time (GT) is defined as the minimum allowable time between the leading edge of two consecutive characters. Character guard time (CGT) is the minimum allowable time between the leading edges of two consecutive characters in the same direction

(transmission or reception). Block guard time (BGT) is the minimum allowable time between the leading edges of two consecutive characters in opposite directions (transmission then reception or reception then transmission).

The GT and WT counters reset whenever $C7816[TTYTYPE] = 1$ or $C7816[ISO_7816E] = 0$ or a new dataword start bit has been received or transmitted as specified by the counter descriptions. The CWT, CGT, BWT, BGT counters reset whenever $C7816[TTYTYPE] = 0$ or $C7816[ISO_7816E] = 0$ or a new dataword start bit has been received or transmitted as specified by the counter descriptions. When $C7816[TTYTYPE] = 1$ some of the counter values require an assumption regarding the first data transferred when the UART first starts. This assumption is required when the 7816E has been disabled, when transition from $C7816[TTYTYPE] = 0$ to $C7816[TTYTYPE] = 1$ or when coming out of reset. In this case, it is assumed that the previous (non-existent) transfer was a received transfer.

The UART will automatically handle GT, CGT and BGT such that the UART will not send a packet prior to the corresponding guard time expiring.

Table 47-205. Wait and guard time calculations

Parameter	Reset value [ETU]	$C7816[TTYTYPE] = 0$ [ETU]	$C7816[TTYTYPE] = 1$ [ETU]
Wait time (WT)	9600	$WI \times 960 \times GTFD$	Not used
Character wait time (CWT)	Not used	Not used	$11 + 2^{CWI}$
Block wait time (BWT)	Not used	Not used	$11 + 2^{BWI} \times 960 \times GTFD$
Guard time (GT)	12	GTN not wqual to 255 $12 + GTN$ GTN wqual to 255 12	Not used
Character guard time (CGT)	Not used	Not used	GTN not equal to 255 $12 + GTN$ GTN equal to 255 11
Block guard time (BGT)	Not used	Not used	22

47.4.7.5 Baud rate generation

The value in $WF7816[GTFD]$ does not impact the clock frequency. The SBR and BRFD are used to generate the clock frequency. This clock frequency is used by the UART only and is not seen by the device (smartcard). The transmitter clocks operates at 1/16 the frequency of the receive clock so that the receiver is able to sample the received value 16 times during the ETU.

47.4.7.6 UART restrictions in ISO-7816 operation

Due to the flexibility of the UART module, there are several features and interrupts that are not supported while running in ISO-7816 mode. These restrictions are documented within the register bit definitions.

47.4.8 Infrared interface

The UART provides the capability of transmitting narrow pulses to an IR LED and receiving narrow pulses and transforming them to serial bits, which are sent to the UART. The IrDA physical layer specification defines a half-duplex infrared communication link for exchanging data. The full standard includes data rates up to 16 Mbits/s. This design covers data rates only between 2.4 kbits/s and 115.2 kbits/s.

The UART has an infrared transmit encoder and receive decoder. The UART transmits serial bits of data which are encoded by the infrared submodule to transmit a narrow pulse for every zero bit. No pulse is transmitted for every one bit. When receiving data, the IR pulses are detected using an IR photo diode and transformed to CMOS levels by the IR receive decoder (external from the MCU). The narrow pulses are then stretched by the infrared receive decoder to get back to a serial bit stream to be received by the UART. The polarity of transmitted pulses and expected receive pulses can be inverted so that a direct connection can be made to external IrDA transceiver modules that use active low pulses.

The infrared submodule receives its clock sources from the UART. One of these two clocks are selected in the infrared submodule in order to generate either 3/16, 1/16, 1/32 or 1/4 narrow pulses during transmission.

47.4.8.1 Infrared transmit encoder

The infrared transmit encoder converts serial bits of data from transmit shift register to the TXD signal. A narrow pulse is transmitted for a zero bit and no pulse for a one bit. The narrow pulse is sent in the middle of the bit with a duration of 1/32, 1/16, 3/16 or 1/4 of a bit time. A narrow high pulse is transmitted for a zero bit when C3[TXINV] is cleared, while a narrow low pulse is transmitted for a zero bit when C3[TXINV] is set.

47.4.8.2 Infrared receive decoder

The infrared receive block converts data from the RXD signal to the receive shift register. A narrow pulse is expected for each zero received and no pulse is expected for each one received. A narrow high pulse is expected for a zero bit when S2[RXINV] is cleared, while a narrow low pulse is expected for a zero bit when S2[RXINV] is set. This receive decoder meets the edge jitter requirement as defined by the IrDA serial infrared physical layer specification.

47.5 Reset

All registers reset to a particular value are indicated in [Memory map and registers](#).

47.6 System level interrupt sources

There are several interrupt signals that are sent from the UART. The following table lists the interrupt sources generated by the UART. The local enables for the UART interrupt sources are described in this table. Details regarding the individual operation of each interrupt are contained under various sub-sections of [Memory map and registers](#). However, [RXEDGIF description](#) also outlines additional details regarding the RXEDGIF interrupt because of its complexity of operation. Any of the UART interrupt requests listed in the table can be used to bring the CPU out of wait mode.

Table 47-206. UART interrupt sources

Interrupt Source	Flag	Local enable	DMA select
Transmitter	TDRE	TIE	TDMAS = 0
Transmitter	TC	TCIE	-
Receiver	IDLE	ILIE	-
Receiver	RDRF	RIE	RDMAS = 0
Receiver	LBKDIF	LBKDIE	-
Receiver	RXEDGIF	RXEDGIE	-
Receiver	OR	ORIE	-
Receiver	NF	NEIE	-
Receiver	FE	FEIE	-
Receiver	PF	PEIE	-
Receiver	RXUF	RXUFE	-
Transmitter	TXOF	TXOFE	-

Table continues on the next page...

Table 47-206. UART interrupt sources (continued)

Interrupt Source	Flag	Local enable	DMA select
Receiver	WT	WTWE	-
Receiver	CWT	CWTE	-
Receiver	BWT	BWTE	-
Receiver	INITD	INITDE	-
Receiver	TXT	TXTE	-
Receiver	RXT	RXTE	-
Receiver	GTV	GTVE	-

47.6.1 RXEDGIF description

The S2[RXEDGIF] is set when an active edge is detected on the RxD pin. Hence, the active edge can only be detected when in two wire mode. A RXEDGIF interrupt is only generated when S2[RXEDGIF] is set. If RXEDGIE is not enabled prior to S2[RXEDGIF] getting set, an interrupt is not generated until S2[RXEDGIF] bit gets set.

47.6.1.1 RxD edge detect sensitivity

Edge sensitivity can be software programmed to be either falling or rising. The polarity of the edge sensitivity is selected using the S2[RXINV] bit. To detect falling edge S2[RXINV] is programmed to zero and to detect rising edge S2[RXINV] is programmed to one.

Synchronizing logic is used prior to detect edges. Prior to detecting an edge, the receive data on RxD input must be at the de-asserted logic level. A falling edge is detected when the RxD input signal is seen as a logic 1 (the deasserted level) during one module clock cycle and then a logic 0 (the asserted level) during the next cycle. A rising edge is detected when the input is seen as a logic 0 during one module clock cycle and then a logic 1 during the next cycle.

47.6.1.2 Clearing RXEDGIF interrupt request

Writing a logic 1 to the S2[RXEDGIF] bit immediately clears the RXEDGIF interrupt request even if the RxD input remains asserted. S2[RXEDGIF] will remain set if another active edge is detected on RxD while attempting to clear the S2[RXEDGIF] flag by writing a 1 to it.

47.6.1.3 Exit from low-power modes

The receive input active edge detect circuit is still active on low power modes (wait and stop). An active edge on the receive input brings the CPU out of low power mode if the interrupt is not masked (S2[RXEDGIF]=1).

47.7 DMA operation

In the transmitter, flags S1[TDRE] can be configured to assert a DMA transfer request. In the receiver, flag S1[RDRF], can be configured to assert a DMA transfer request. The following table shows the configuration bit settings required to configure each flag for DMA operation.

Table 47-207. DMA configuration

Flag	Request enable bit	DMA select bit
TDRE	TIE = 1	TDMAS = 1
RDRF	RIE = 1	RDMAS = 1

When a flag is configured for a DMA request, its associated DMA request is asserted when the flag is set. When the S1[RDRF] flag is configured as a DMA request, the clearing mechanism of reading S1 register followed by reading D register does not clear the associated flag. The DMA request remains asserted until an indication is received that the DMA transactions are done. When this indication is received, the flag bit and the associated DMA request are cleared. If the DMA operation failed to remove the situation that caused the DMA request another request will be issued.

47.8 Application information

This section describes the UART application information.

47.8.1 Transmit/receive data buffer operation

The UART has independent receive and transmit buffers. The size of these buffers may vary depending on the implementation of the module. The implemented size of the buffers is a fixed constant via the PFIFO[TXFIFOSIZE] and PFIFO[RXFIFOSIZE] fields. Additionally, legacy support is provided that allows for the FIFO structure to

operate as a depth of one. This is the default/reset behavior of the module and can be adjusted using the PFIFO[RXFEB] and PFIFO[TXFEB] bits. Individual watermark levels are also provided for transmit and receive.

There are multiple ways to ensure that a data block (set of characters) has completed transmission. These methods include:

1. Set TXFIFO[TXWATER] to 0. The TDRE flag will assert when there is no further data in the transmit buffer. Alternatively the S1[TC] flag can be used to indicate when the transmit shift register is also empty.
2. Poll the TCFIFO[TXCOUNT] field. Assuming that only data for a data block has been put into the data buffer, when TCFIFO[TXCOUNT] = 0 all data has been transmitted or is in the process of transmission.
3. The S1[TC] flag can be monitored. When S1[TC] asserts it indicates that all data has been transmitted and there is no data currently being transmitted in the shift register.

47.8.2 ISO-7816 initialization sequence

This section outlines how to program the UART for ISO-7816 operation. Elements such as procedures to power up or power down the smartcard, and when to take those actions, are beyond the scope of this description. To setup the UART for ISO-7816 operation:

1. Select a baud rate. Write this value to the UART baud registers (BDH/L) to begin the baud rate generator. Remember that the baud rate generator is disabled when the baud rate is zero. Writing to the BDH has no effect without also writing to BDL. According to the 7816 specification the initial (default) baud rating setting should be $F_i = 372$ and $D_i = 1$ and a maximum frequency of 5 MHz. In other words the BDH, BDL and C4 registers should be programmed such that the transmission frequency should be 1/372th of the clock provided to the smartcard device and should not exceed 5 MHz.
2. Write to set BDH[LBKDIE] = 0.
3. Write to C1 to configure word length, parity, and other configuration bits (LOOPS, RSRC) and set C1[M] = 1, C1[PE] = 1, C1[PT] = 0.
4. Write to set S2[RWUID] = 0, S2[LBKDE] = 0.
5. Write to set MODEM[RXRTSE] = 0, MODEM[TXRTSPOL] = 0, MODEM[TXRTSE] = 0, and MODEM[TXCTSE] = 0.

6. Write to set up interrupt enable bits desired (C3[ORIE], C3[NEIE], C3[PEIE], and C3[FEIE])
7. Write to set C4[MAEN1] = 0 and C4[MAEN2] = 0.
8. Write to C5 register and configure DMA control register bits as desired for application.
9. Write to set C7816[INIT] = 1, C7816[TTYTYPE] = 0, 7C7816[ISO_7816E] = 1. Program C7816[ONACK] and C7816[ANACK] as desired.
10. Write to IE7816 register to set interrupt enable parameters as desired.
11. Write to ET7816 register and set as desired.
12. Write to set C2[ILIE] = 0, C2[RE] = 1, C2[TE] = 1, C2[RWU] = 0 and C2[SBK] = 0. Setup interrupt enables C2[TIE], C2[TCIE] and C2[RIE] as desired.

At this time the UART will start listening for an initial character. Once identified it will automatically adjust the S2[MSBF], C3[TXINV] and S2[RXINV] bits. The software should then receive and process an answer to reset. Upon processing the answer to reset software should write to set C2[RE] = 0 and C2[TE] = 0. Software should then adjust 7816 specific and UART generic parameters to match and configuration data that was received during the answer on reset period. Once the new settings have been programmed (including the new baud rate and C7816[TTYTYPE]) the C2[RE] and C2[TE] can be re-enabled as required.

47.8.2.1 Transmission procedure for (C7816[TTYTYPE] = 0)

When the protocol selected is C7816[TTYTYPE] = 0, it is assumed that the software has a prior knowledge of who should be transmitting and receiving. Hence, no mechanism is provided for automated transmission/receipt control. Software should monitor the S1[TDRE] flag (or configure for an interrupt) and provide additional data for transmission as appropriate. Additionally, software should set C2[TE] = 1 and control TXDIR whenever it is the UART's turn to transmit information. For ease of monitoring it is suggested that only data to be transmitted until the next receiver/transmit switch over be loaded into the transmit buffer/FIFO.

47.8.2.2 Transmission procedure for (C7816[TTYPE] = 1)

When the protocol selected is C7816[TTYPE] = 1, data is transferred in blocks. Prior to starting a transmission software should write the size (number of bytes) for the Information Field portion of the block in to the TLEN register. If a CRC is being transmitted for the block the value in TLEN should be one more than the size of the information field. Software should then set C2[TE] = 1, and C2[RE] = 1. Software should then monitor the S1[TDRE] flag / interrupt and write the prologue, Information and epilogue field to the transmit buffer. The TLEN register will automatically decrement (except for prologue bytes and the final epilogue byte). When the final epilogue byte has been transmitted the UART automatically clears the C2[TE] bit to 0, and the UART automatically starts capturing the response to the block that was transmitted. Once software has detected the receipt of the response, the transmission process should be repeated as needed with sufficient urgency to ensure that the block wait time and character wait times are not violated.

47.8.3 Initialization sequence (non ISO-7816)

To initiate an UART transmission:

1. Configure the UART:
 - a. Select a baud rate. Write this value to the UART baud registers (BDH/L) to begin the baud rate generator. Remember that the baud rate generator is disabled when the baud rate is zero. Writing to the BDH register has no effect without also writing to BDL register.
 - b. Write to C1 register to configure word length, parity, and other configuration bits (LOOPS, RSRC, M, WAKE, ILT, PE, PT). Write to C4, MA1 and MA2 register to configure.
 - c. Enable the transmitter, interrupts, receiver, and wakeup as required by writing to the C2 register bits (TIE, TCIE, RIE, ILIE, TE, RE, RWU, SBK), S2 register bits (MSBF, BRK13) and C3 register bits (ORIE, NEIE, PEIE, FEIE). A preamble or idle character is then shifted out of the transmitter shift register.
2. Transmit procedure for each byte:
 - a. Monitor the S1[TDRE] flag by reading the S1 or responding to the TDRE interrupt. Or monitor the amount of free space in the transmit buffer directly using TCFIFO[TXCOUNT].

- b. If the TDRE flag is set, or there is space in the transmit buffer, write the data to be transmitted to (C3[T8]/D). A new transmission will not result until data exists in the transmit buffer.
3. Repeat step 2 for each subsequent transmission.

Note

During normal operation, the S1[TDRE] flag is set when the shift register is loaded with the next data to be transmitted from the transmit buffer and the number of datawords contained in the transmit buffer is less than or equal to the value in TWFIFO[TXWATER], which occurs 9/16ths of a bit time after the start of the stop bit of the previous frame.

To separate messages with preambles with minimum idle line time, use this sequence between messages:

1. Write the last dataword of the first message to C3[T8]/D.
2. Wait for the S1[TDRE] flag to go high (with TWFIFO[TXWATER] = 0), indicating the transfer of the last frame to the transmit shift register.
3. Queue a preamble by clearing and then setting the C2[TE] bit.
4. Write the first (and subsequent) datawords of the second message to C3[T8]/D.

47.8.4 Overrun (OR) flag implications

To be flexible the overrun flag (OR) operates slightly differently depending on the mode of operation. As such there may be implications that need to be carefully considered. This section clarifies that behavior and the resulting implications. Regardless of mode, if a dataword is received while the S1[OR] flag is set, the S1[RDRF] and S1[IDLE] flags are blocked from asserting. If the S1[RDRF] or S1[IDLE] flag were previously asserted they will remain asserted until cleared.

47.8.4.1 Overrun operation

The assertion of the S1[OR] flag indicates that a significant event has occurred. The assertion indicates that received data has been lost since there was a lack of room to store it in the data buffer. Hence, while the S1[OR] flag is set no further data will be stored in the data buffer until the S1[OR] flag is cleared. This ensures that the application will be able to handle the overrun condition.

In most applications since the total amount of lost data is known, the application will desire to return the system to a known state. Prior to the S1[OR] flag being cleared all received data will be dropped. To do this the software would:

1. Remove data from the receive data buffer. This could be done by reading data from the data buffer and processing it if the data in the FIFO was still valuable when though the overrun event occurred or using the CFIFO[RXFLUSH] bit to clear the buffer.
2. Clear the S1[OR] flag. Note that if data was cleared using the CFIFO[RXFLUSH] bit, then clearing the S1[OR] flag will result in the SFIFO[RXUF] flag asserting because the only way to clear the S1[OR] requires reading additional information from the FIFO. Care should be taken to disable the SFIFO[RXUF] interrupt prior to clearing the OR flag and then clearing the SFIFO[RXUF] flag after the OR flag has been cleared.

Note that in some applications if an overrun event is responded to fast enough, the lost data can be recovered. For example when C7816[ISO_7816E] is asserted, C7816[TTYTYPE]=1 and C7816[ONACK] = 1 the application may reasonably be able to determine if the lost data will be resent by the device. In this scenario flushing the receiver data buffer might not be required. Rather, if the S1[OR] flag is cleared the lost data may be resent and hence recoverable.

When LIN break detect (LBKDE) is asserted the S1[OR] flag has significantly different behavior than in other modes. The S1[OR] bit will be set, regardless of how much space is actually available in the data buffer, if a LIN break character has been detected and the corresponding flag (S2[LBKDIF]) is not cleared before the first data character is received after the S2[LBKDIF] asserted. This behavior is intended to allow software sufficient time to read the LIN break character from the data buffer to ensure that a break character was actually detected. The checking of the break character was used on some older implementations and is hence supported for legacy reasons. Applications that do not require this checking can simply clear the S2[LBKDIF] without checking the stored value to ensure it is a break character.

47.8.5 Overrun NACK considerations

When C7816[ISO_7816E] is enabled and C7816[TTYTYPE] = 0 the retransmission feature of the 7816 protocol can be used to help avoid lost data when the data buffer overflows. Using C7816[ONACK] the module can be programmed to issue a NACK on an overflow event. Assuming that the device (smartcard) has implemented retransmission, the lost data will be retransmitted. While useful, there is a programming implication which may require special consideration. The need to transmit a NACK must be determined and

committed to prior to the dataword being fully received. While the NACK is being received it is possible that the application code will read the data buffer such that sufficient room will be made to store the dataword that is being NACKed. Even if room has been made in the data buffer once the transmission of a NACK is completed, the received data will always be discarded as a result of an overflow and the ET7816[RXTHRESHOLD] value will be incremented by one. However, if sufficient space now exists to write the received data which was NACK'ed the S1[OR] flag will be blocked and kept from asserting.

47.8.6 Match address registers

The two match address registers allow a second match address function for a broadcast or general call address to the serial bus, as an example.

47.8.7 Modem feature

This section describes the modem features.

47.8.7.1 Ready-to-receive using $\overline{\text{RTS}}$

To help to stop overrun of the receiver data buffer, the $\overline{\text{RTS}}$ signal can be used by the receiver to indicate to another UART that it is ready to receive data. The other UART can send the data when its $\overline{\text{CTS}}$ signal is asserted. This handshaking conforms to the TIA-232-E standard. A transceiver is necessary if the required voltage levels of the communication link do not match the voltage levels of the UART's $\overline{\text{RTS}}$ and $\overline{\text{CTS}}$ signals.

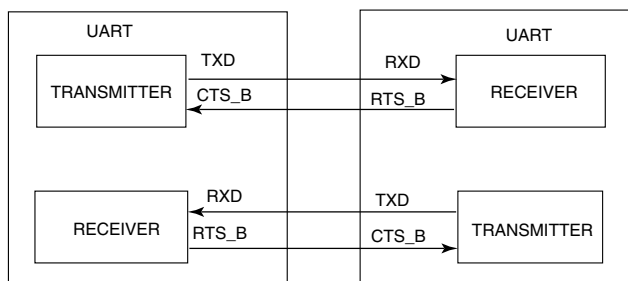

Figure 47-214. Ready-to-receive

The transmitter's $\overline{\text{CTS}}$ signal can be used for hardware flow control whether its $\overline{\text{RTS}}$ signal is used for hardware flow control, transceiver driver enable, or not at all.

47.8.7.2 Transceiver driver enable using $\overline{\text{RTS}}$

RS-485 is a multiple drop communication protocol in which the UART transceiver's driver is 3-stated unless that UART is driving. The $\overline{\text{RTS}}$ signal can be used by the transmitter to enable the driver of a transceiver. The polarity of $\overline{\text{RTS}}$ can be matched to the polarity of the transceiver's driver enable signal. Refer to the following figure.

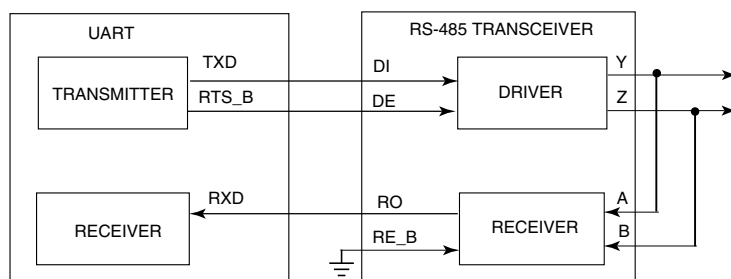

Figure 47-215. Transceiver driver enable using $\overline{\text{RTS}}$

In the figure, the receiver enable signal is asserted. Another option for that connection is to connect $\overline{\text{RTS_B}}$ to both DE and RE_B . The transceiver's receiver is disabled while driving. A pullup can pull RXD to a non-floating value during this time. This option can be refined further by operating the UART in single-wire mode, freeing the RXD pin for other uses.

47.8.8 IrDA minimum pulse width

The IrDA specifies a minimum pulse width of 1.6 μs . The UART hardware does not include a mechanism to restrict/force the pulse width to be greater than or equal to 1.6 μs . However, configuring the baud rate to 115.2 kbit/s and the narrow pulse width to 3/16 of a bit time results in a pulse width of 1.6 μs .

47.8.9 Clearing 7816 wait timer (WT, BWT, CWT) interrupts

The 7816 wait timer interrupts associated with IS7816[WT] , IS7816[BWT] and IS7816[CWT] will automatically reassert if they are cleared and the wait time is still violated. This behavior is similar to most of the other interrupts on the UART as in most cases if the condition that caused the interrupt to trigger still exists when the interrupt is cleared, then the interrupt will reassert. For example, consider the following scenario:

1. IS7816[WT] is programmed to assert after 9600 cycles of unresponsiveness.
2. The 9600 cycles pass without a response resulting in the WT interrupt asserting.
3. The IS7816[WT] is cleared at cycle 9700 by the interrupt service routine.

4. After the WT interrupt has been cleared, the smartcard remains unresponsive. At cycle 9701 the WT interrupt will reasserted.

If the intent of clearing the interrupt is such that it does not reassert, the interrupt service routine must remove or clear the condition that originally caused the interrupt to assert prior to clearing the interrupt. There are multiple ways that this can be accomplished including ensuring that an event that results in the wait timer resetting occurs such as the transmission of another packet.

47.8.10 Legacy and reverse compatibility considerations

Recent versions of the UART have added several new features. Whenever reasonably possible reverse compatibility was maintained, however, in some cases this was either not feasible or the behavior was deemed as not intended. This section describes several differences to legacy operation that resulted from these recent enhancements. If application codes from previous versions is used, they should be reviewed and modified to take the following items into account. Depending on the application code, additional items that are not listed here may also need to be considered.

1. Various reserved registers and register bits were used (i.e. MSFB and M10).
2. This module now generates an error when invalid address spaces are used.
3. While documentation indicated otherwise, in some cases it was possible for S1[IDLE] to assert even if S1[OR] was set.
4. The S1[OR] flag will only be set if the data buffer (FIFO) does not have sufficient room. Previously, the data buffer was always a fixed size of one and the S1[OR] flag would set so long as the S1[RDRF] flag was set even if there was room in the data buffer. While the clearing mechanism is has remained the save for the S1[RDRF] flag, keeping the OR flag assertion tied to the RDRF event rather than the data buffer being full would have greatly reduced the usefulness of the buffer when its size is larger than one.
5. Previously when the C2[RWU] was set (and WAKE = 0), the IDLE flag could reassert up to every bit period causing an interrupt and requiring the host processor to reassert the C2[RWU] bit. This behavior has been modified. Now, when the C2[RWU] is set (and WAKE = 0) at least one non-idle bit must be detected before an idle can be detected.



Chapter 48

Secured digital host controller (SDHC)

48.1 Introduction

NOTE

For the chip-specific implementation details of this module's instances see the chip configuration chapter.

The chapter is intended for a module driver software developer. It describes module-level operation and programming.

48.2 Overview

48.2.1 Supported types of cards

Different types of cards supported by the SDHC are described briefly as follows:

The multi-media card (MMC) is a universal low cost data storage and communication media that is designed to cover a wide area of applications including mobile video and gaming. Old MMC cards are based on a 7-pin serial bus with a single data pin, while the new high speed MMC communication is based on an advanced 11-pin serial bus designed to operate in the low voltage range.

The secure digital card (SD) is an evolution of the old MMC technology. It is specifically designed to meet the security, capacity, performance, and environment requirements inherent in newly emerging audio and video consumer electronic devices. The physical form factor, pin assignment and data transfer protocol are forward compatible with the old MMC (with some additions).

Under the SD protocol, it can be categorized into memory card, I/O card and combo card, which has both memory and I/O functions. The memory card invokes a copyright protection mechanism that complies with the security of the SDMI standard. The I/O

card, which is also known as SDIO card, provides high-speed data I/O with low power consumption for mobile electronic devices. For the sake of simplicity, the figure does not show cards with reduced size or mini cards.

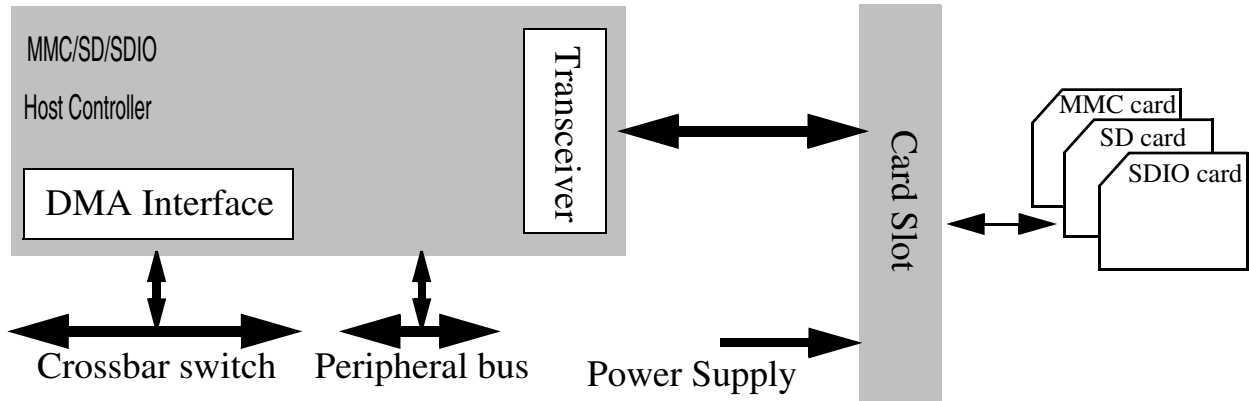

Figure 48-1. System connection of the SDHC

CE-ATA is a hard drive interface that is optimized for embedded applications storage. The device is layered on the top of the MMC protocol stack using the same physical interface. The interface electrical and signaling definition is defined like that in the MMC specification. Refer to the CE-ATA specification for more details.

48.2.2 SDHC block diagram

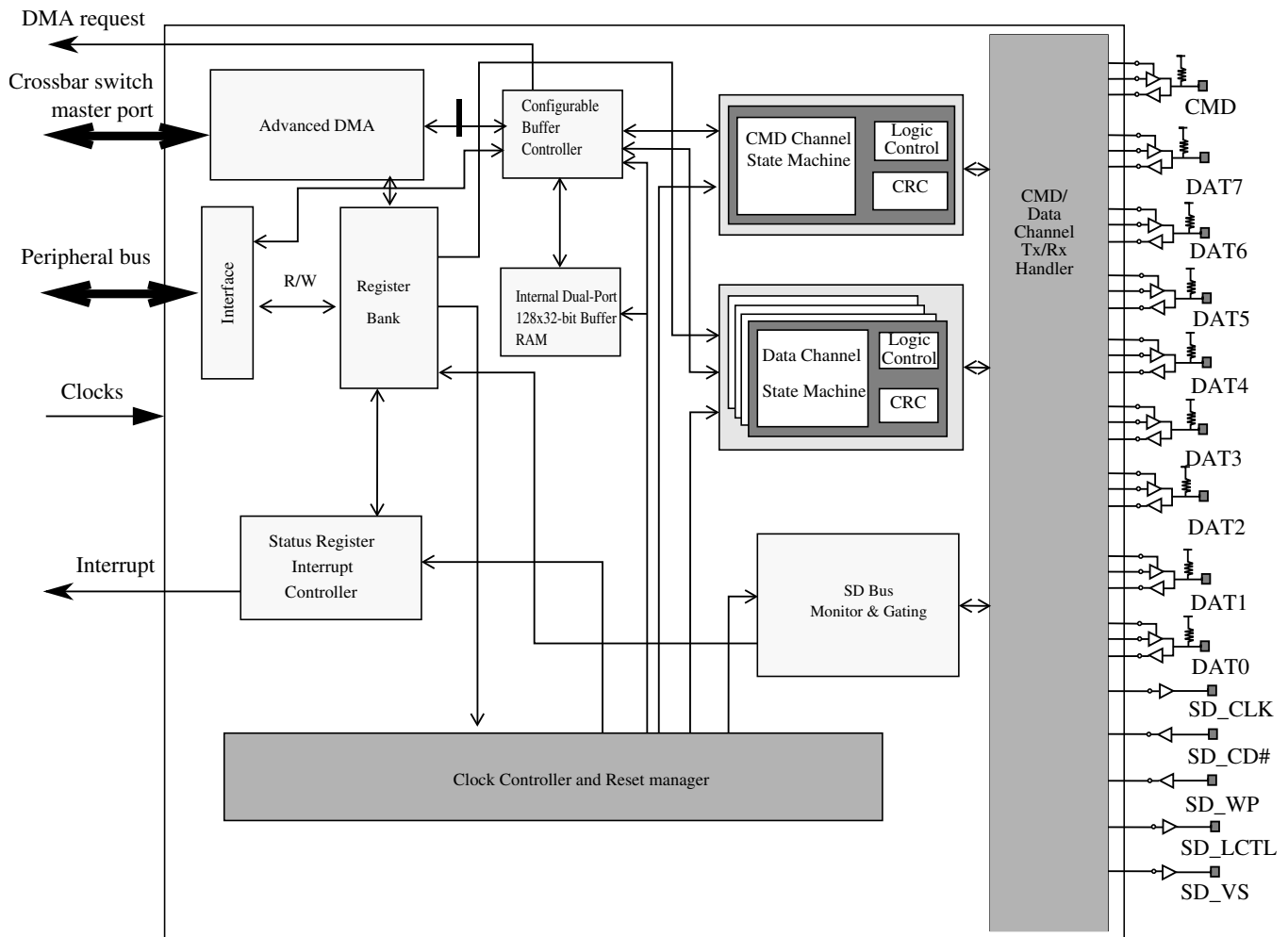

Figure 48-2. Enhanced secure digital host controller block diagram

48.2.3 Features

The features of the SDHC module include the following:

- Conforms to the SD Host Controller Standard Specification version 2.0 including test event register support
- Compatible with the MMC System Specification version 4.2/4.3
- Compatible with the SD Memory Card Specification version 2.0 and supports the high capacity SD memory card
- Compatible with the SDIO Card Specification version 2.0
- Compatible with the CE-ATA Card Specification version 1.0

- Designed to work with CE-ATA, SD memory, miniSD memory, SDIO, miniSDIO, SD Combo, MMC, MMC plus, and MMC RS cards
- Card bus clock frequency up to 52 MHz
- Supports 1-bit / 4-bit SD and SDIO modes, 1-bit / 4-bit / 8-bit MMC modes, 1-bit / 4-bit / 8-bit CE-ATA devices
 - Up to 200 Mbps of data transfer for SD/SDIO cards using 4 parallel data lines
 - Up to 416 Mbps of data transfer for MMC cards using 8 parallel data lines in SDR (single data rate) mode
- Supports single block, multi-block read and write
- Supports block sizes of 1 ~ 4096 bytes
- Supports the write protection switch for write operations
- Supports both synchronous and asynchronous abort (both hardware and software CMD12)
- Supports pause during the data transfer at block gap
- Supports SDIO read wait and suspend resume operations
- Supports auto CMD12 for multi-block transfer
- Host can initiate non-data transfer command while data transfer is in progress
- Allows cards to interrupt the host in 1-bit and 4-bit SDIO modes, also supports interrupt period
- Embodies a fully configurable 128x32-bit FIFO for read/write data
- Supports internal and external DMA capabilities
- Supports advanced DMA to perform linked memory access

48.2.4 Modes and operations

The SDHC can select the following modes for data transfer:

- SD 1-bit
- SD 4-bit
- MMC 1-bit

- MMC 4-bit
- MMC 8-bit
- CE-ATA 1-bit
- CE-ATA 4-bit
- CE-ATA 8-bit
- Identification mode (up to 400 kHz)
- MMC full speed mode (up to 20 MHz)
- MMC high speed mode (up to 52 MHz)
- SD/SDIO full speed mode (up to 25 MHz)
- SD/SDIO high speed mode (up to 50 MHz)

48.3 SDHC signal descriptions

Table 48-1. SDHC signal descriptions

Signal	Description	I/O
SDHC_DCLK	Generated clock used to drive the MMC, SD, SDIO or CE-ATA cards.	O
SDHC_CMD	Send commands to and receive responses from the card.	I/O
SDHC_D0	DAT0 line or busy-state detect	I/O
SDHC_D1	8-bit mode: DAT1 line 4-bit mode: DAT1 line or interrupt detect 1-bit mode: Interrupt detect	I/O
SDHC_D2	4-/8-bit mode: DAT2 line or read wait 1-bit mode: Read wait	I/O
SDHC_D3	4-/8-bit mode: DAT3 line or configured as card detection pin 1-bit mode: May be configured as card detection pin	I/O
SDHC_D4	DAT4 line in 8-bit mode Not used in other modes	I/O
SDHC_D5	DAT5 line in 8-bit mode Not used in other modes	I/O

Table continues on the next page...

Table 48-1. SDHC signal descriptions (continued)

Signal	Description	I/O
SDHC_D6	DAT6 line in 8-bit mode Not used in other modes	I/O
SDHC_D7	DAT7 line in 8-bit mode Not used in other modes	I/O

48.4 Memory map and register definition

This section includes the module memory map and detailed descriptions of all registers.

SDHC memory map

Absolute address (hex)	Register name	Width (in bits)	Access	Reset value	Section/page
400B_1000	DMA System Address Register (SDHC_DSADDR)	32	R/W	0000_0000h	48.4.1/1335
400B_1004	Block Attributes Register (SDHC_BLKATTR)	32	R/W	0000_0000h	48.4.2/1336
400B_1008	Command Argument Register (SDHC_CMDARG)	32	R/W	0000_0000h	48.4.3/1337
400B_100C	Transfer Type Register (SDHC_XFERTYP)	32	R/W	0000_0000h	48.4.4/1338
400B_1010	Command Response 0 (SDHC_CMDRSP0)	32	R	0000_0000h	48.4.5/1342
400B_1014	Command Response 1 (SDHC_CMDRSP1)	32	R	0000_0000h	48.4.6/1343
400B_1018	Command Response 2 (SDHC_CMDRSP2)	32	R	0000_0000h	48.4.7/1343
400B_101C	Command Response 3 (SDHC_CMDRSP3)	32	R	0000_0000h	48.4.8/1343
400B_1020	Buffer Data Port Register (SDHC_DATPORT)	32	R/W	0000_0000h	48.4.9/1345
400B_1024	Present State Register (SDHC_PRSTAT)	32	R	0000_0000h	48.4.10/1345
400B_1028	Protocol Control Register (SDHC_PROCTL)	32	R/W	0000_0020h	48.4.11/1350
400B_102C	System Control Register (SDHC_SYSCTL)	32	R/W	0000_8008h	48.4.12/1354

Table continues on the next page...

SDHC memory map (continued)

Absolute address (hex)	Register name	Width (in bits)	Access	Reset value	Section/page
400B_1030	Interrupt Status Register (SDHC_IRQSTAT)	32	R/W	0000_0000h	48.4.13/ 1357
400B_1034	Interrupt Status Enable Register (SDHC_IRQSTATEN)	32	R/W	117F_013Fh	48.4.14/ 1363
400B_1038	Interrupt Signal Enable Register (SDHC_IRQSIGEN)	32	R/W	0000_0000h	48.4.15/ 1366
400B_103C	Auto CMD12 Error Status Register (SDHC_AC12ERR)	32	R	0000_0000h	48.4.16/ 1368
400B_1040	Host Controller Capabilities (SDHC_HTCAPBLT)	32	R	07F3_0000h	48.4.17/ 1371
400B_1044	Watermark Level Register (SDHC_WML)	32	R/W	0010_0010h	48.4.18/ 1373
400B_1050	Force Event Register (SDHC_FEVT)	32	W (always reads zero)	0000_0000h	48.4.19/ 1373
400B_1054	ADMA Error Status Register (SDHC_ADMAES)	32	R	0000_0000h	48.4.20/ 1376
400B_1058	ADMA System Address Register (SDHC_DSADDR)	32	R/W	0000_0000h	48.4.21/ 1378
400B_10C0	Vendor Specific Register (SDHC_VENDOR)	32	R/W	0000_0001h	48.4.22/ 1378
400B_10C4	MMC Boot Register (SDHC_MMCBOOT)	32	R/W	0000_0000h	48.4.23/ 1380
400B_10FC	Host Controller Version (SDHC_HOSTVER)	32	R	0000_1201h	48.4.24/ 1381

48.4.1 DMA System Address Register (SDHC_DSADDR)

This register contains the physical system memory address used for DMA transfers.

Address: SDHC_DSADDR is 400B_1000h base + 0h offset = 400B_1000h

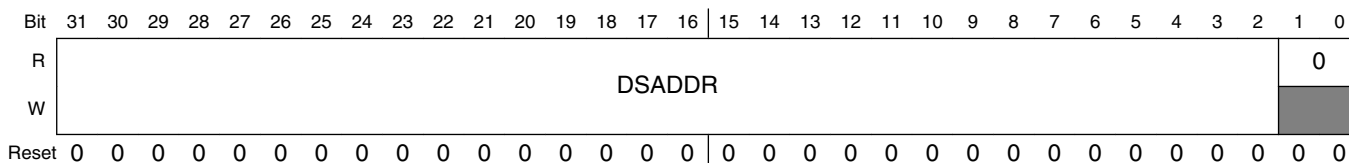

SDHC_DSADDR field descriptions

Field	Description
31–2 DSADDR	DMA System Address

Table continues on the next page...

SDHC_DSADDR field descriptions (continued)

Field	Description
	<p>This register contains the 32-bit system memory address for a DMA transfer. Since the address must be word (4 bytes) align, the least 2 bits are reserved, always 0. When the SDHC stops a DMA transfer, this register points to the system address of the next contiguous data position. It can be accessed only when no transaction is executing (i.e. after a transaction has stopped). Read operation during transfers may return an invalid value. The host driver shall initialize this register before starting a DMA transaction. After DMA has stopped, the system address of the next contiguous data position can be read from this register. This register is protected during a data transfer. When data lines are active, write to this register is ignored. The host driver shall wait, until the PRSSTAT[DLA] is cleared, before writing to this register.</p> <p>The SDHC internal DMA does not support a virtual memory system. It only supports continuous physical memory access. And due to AHB burst limitations, if the burst must cross the 1 KB boundary, SDHC will automatically change SEQ burst type to NSEQ.</p> <p>Since this register supports dynamic address reflecting, when IRQSTAT[TC] bit is set, it automatically alters the value of internal address counter, so SW cannot change this register when IRQSTAT[TC] bit is set.</p>
1-0 Reserved	This read-only field is reserved and always has the value zero.

48.4.2 Block Attributes Register (SDHC_BLKATTR)

This register is used to configure the number of data blocks and the number of bytes in each block.

Address: SDHC_BLKATTR is 400B_1000h base + 4h offset = 400B_1004h

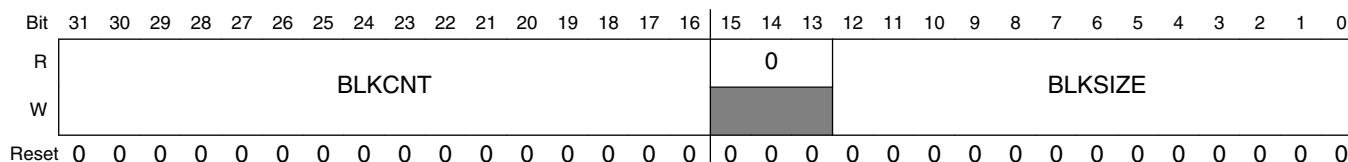

SDHC_BLKATTR field descriptions

Field	Description
31-16 BLKCNT	<p>Blocks Count For Current Transfer</p> <p>This register is enabled when the XFERTYP[BCEN] is set to 1 and is valid only for multiple block transfers. For single block transfer, this register will always read as 1. The host driver shall set this register to a value between 1 and the maximum block count. The SDHC decrements the block count after each block transfer and stops when the count reaches zero. Setting the block count to 0 results in no data blocks being transferred.</p> <p>This register should be accessed only when no transaction is executing (that is after transactions are stopped). During data transfer, read operations on this register may return an invalid value and write operations are ignored.</p> <p>When saving transfer content as a result of a suspend command, the number of blocks yet to be transferred can be determined by reading this register. The reading of this register should be applied after transfer is paused by stop at block gap operation and before sending the command marked as suspend. This is because when suspend command is sent out, SDHC will regard the current transfer is aborted and change BLKCNT back to its original value instead of keeping the dynamical indicator of remained block count.</p>

Table continues on the next page...

SDHC_BLKATTR field descriptions (continued)

Field	Description
	<p>When restoring transfer content prior to issuing a resume command, the host driver shall restore the previously saved block count.</p> <p>NOTE: Although the BLKCNT field is 0 after reset, the read of reset value is 0x1. This is because when XFERTYP[MSBSEL] bit is 0, indicating a single block transfer, the read value of BLKCNT is always 1.</p> <p>0000h Stop count 0001h 1 block 0002h 2 blocks ... FFFFh 65535 blocks</p>
15–13 Reserved	This read-only field is reserved and always has the value zero.
12–0 BLKSIZE	<p>Transfer Block Size</p> <p>This register specifies the block size for block data transfers. Values ranging from 1 byte up to the maximum buffer size can be set. It can be accessed only when no transaction is executing (that is after a transaction has stopped). Read operations during transfers may return an invalid value, and write operations will be ignored.</p> <p>000h No data transfer 001h 1 Byte 002h 2 Bytes 003h 3 Bytes 004h 4 Bytes ... 1FFh 511 Bytes 200h 512 Bytes ... 800h 2048 Bytes ... 1000h 4096 Bytes</p>

48.4.3 Command Argument Register (SDHC_CMDARG)

This register contains the SD/MMC command argument.

Address: SDHC_CMDARG is 400B_1000h base + 8h offset = 400B_1008h

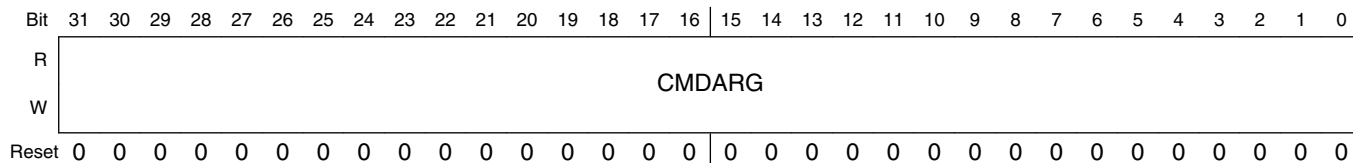

SDHC_CMDARG field descriptions

Field	Description
31–0 CMDARG	<p>Command Argument</p> <p>The SD/MMC command argument is specified as bits 39-8 of the command format in the SD or MMC specification. This register is write protected when the PRSSTAT[CDIHB0] bit is set.</p>

48.4.4 Transfer Type Register (SDHC_XFERTYP)

This register is used to control the operation of data transfers. The host driver shall set this register before issuing a command followed by a data transfer, or before issuing a resume command. To prevent data loss, the SDHC prevents writing to the bits, that are involved in the data transfer of this register, when data transfer is active. These bits are DPSEL, MBSEL, DTDSEL, AC12EN, BCEN and DMAEN.

The host driver shall check the PRSSTAT[CDIHB] and the PRSSTAT[CIHB] before writing to this register. When the PRSSTAT[CDIHB] is set, any attempt to send a command with data by writing to this register is ignored; when the PRSSTAT[CIHB] bit is set, any write to this register is ignored.

On sending commands with data transfer involved, it is mandatory that the block size is non-zero. Besides, block count must also be non-zero, or indicated as single block transfer (bit 5 of this register is '0' when written), or block count is disabled (bit 1 of this register is '0' when written), otherwise SDHC will ignore the sending of this command and do nothing. For write command, with all above restrictions, it is also mandatory that the write protect switch is not active (WPSPL bit of Present State Register is '1'), otherwise SDHC will also ignore the command.

If the commands with data transfer does not receive the response in 64 clock cycles, i.e., response time-out, SDHC will regard the external device does not accept the command and abort the data transfer. In this scenario, the driver should issue the command again to re-try the transfer. It is also possible that for some reason the card responds the command but SDHC does not receive the response, and if it is internal DMA (either simple DMA or ADMA) read operation, the external system memory is over-written by the internal DMA with data sent back from the card.

The following table shows the summary of how register settings determine the type of data transfer.

Table 48-7. Transfer Type Register Setting for Various Transfer Types

Multi/Single block select	Block count enable	Block count	Function
0	Don't care	Don't care	Single transfer

Table continues on the next page...

Table 48-7. Transfer Type Register Setting for Various Transfer Types (continued)

Multi/Single block select	Block count enable	Block count	Function
1	0	Don't care	Infinite transfer
1	1	Positive number	Multiple transfer
1	1	Zero	No data transfer

The following table shows the relationship between the XFERTYP[CICEN] and XFERTYP[CCCEN], in regards to the XFERTYP[RSPTYP] as well as the name of the response type.

Table 48-8. Relationship Between Parameters and the Name of the Response Type

Response type (RSPTYP)	Index check enable (CICEN)	CRC check enable (CCCEN)	Name of response type
00	0	0	No Response
01	0	1	IR2
10	0	0	R3,R4
10	1	1	R1,R5,R6
11	1	1	R1b,R5b

NOTE

- In the SDIO specification, response type notation for R5b is not defined. R5 includes R5b in the SDIO specification. But R5b is defined in this specification to specify that the SDHC will check the busy status after receiving a response. For example, usually CMD52 is used with R5, but the I/O abort command shall be used with R5b.
- The CRC field for R3 and R4 is expected to be all 1 bits. The CRC check shall be disabled for these response types.

memory map and register definition

Address: SDHC_XFERTYP is 400B_1000h base + Ch offset = 400B_100Ch

Bit	31	30	29	28	27	26	25	24	23	22	21	20	19	18	17	16
R	0		CMDINX						CMDTYP		DPSEL	CICEN	CCEN	0	RSPTYP	
W																
Reset	0	0	0	0	0	0	0	0	0	0	0	0	0	0	0	0
Bit	15	14	13	12	11	10	9	8	7	6	5	4	3	2	1	0
R	0								MSBSEL	DTDSEL	0	AC12EN	BCEN	DMAEN		
W																
Reset	0	0	0	0	0	0	0	0	0	0	0	0	0	0	0	0

SDHC_XFERTYP field descriptions

Field	Description
31–30 Reserved	This read-only field is reserved and always has the value zero.
29–24 CMDINX	Command Index These bits shall be set to the command number that is specified in bits 45-40 of the command-format in the SD Memory Card Physical Layer Specification and SDIO Card Specification.
23–22 CMDTYP	Command Type There are three types of special commands: suspend, resume and abort. These bits shall be set to 00b for all other commands. <ul style="list-style-type: none"> • Suspend command: If the suspend command succeeds, the SDHC shall assume that the card bus has been released and that it is possible to issue the next command which uses the DAT line. Since the SDHC does not monitor the content of command response, it does not know if the suspend command succeeded or not. It is the host driver's responsibility to check the status of the suspend command and send another command marked as suspend to inform the SDHC that a suspend command was successfully issued. After the end bit of command is sent, the SDHC de-asserts read wait for read transactions and stops checking busy for write transactions. In 4-bit mode, the interrupt cycle starts. If the suspend command fails, the SDHC will maintain its current state, and the host driver shall restart the transfer by setting the PROCTL[CREQ]. • Resume command: The host driver re-starts the data transfer by restoring the registers saved before sending the suspend command and then sends the resume command. The SDHC will check for a pending busy state before starting write transfers. • Abort command: If this command is set when executing a read transfer, the SDHC will stop reads to the buffer. If this command is set when executing a write transfer, the SDHC will stop driving the DAT line. After issuing the abort command, the host driver should issue a software reset (abort transaction). 00b Normal other commands 01b Suspend CMD52 for writing bus suspend in CCCR 10b Resume CMD52 for writing function select in CCCR 11b Abort CMD12, CMD52 for writing I/O abort in CCCR
21 DPSEL	Data Present Select

Table continues on the next page...

SDHC_XFERTYP field descriptions (continued)

Field	Description
	<p>This bit is set to 1 to indicate that data is present and shall be transferred using the DAT line. It is set to 0 for the following:</p> <ul style="list-style-type: none"> • Commands using only the CMD line (for example: CMD52). • Commands with no data transfer, but using the busy signal on DAT[0] line (R1b or R5b, for example: CMD38). <p>NOTE: In resume command, this bit shall be set, and other bits in this register shall be set the same as when the transfer was initially launched. When the Write Protect switch is on, (i.e. the WPSPL bit is active as '0'), any command with a write operation will be ignored. That is to say, when this bit is set, while the DTSEL bit is 0, writes to the register Transfer Type are ignored.</p> <p>0b No data present 1b Data present</p>
20 CICEN	<p>Command Index Check Enable</p> <p>If this bit is set to 1, the SDHC will check the index field in the response to see if it has the same value as the command index. If it is not, it is reported as a command index error. If this bit is set to 0, the index field is not checked.</p> <p>0b Disable 1b Enable</p>
19 CCEN	<p>Command CRC Check Enable</p> <p>If this bit is set to 1, the SDHC shall check the CRC field in the response. If an error is detected, it is reported as a Command CRC Error. If this bit is set to 0, the CRC field is not checked. The number of bits checked by the CRC field value changes according to the length of the response.</p> <p>0b Disable 1b Enable</p>
18 Reserved	<p>This read-only field is reserved and always has the value zero.</p>
17–16 RSPTYP	<p>Response Type Select</p> <p>00b No response 01b Response length 136 10b Response length 48 11b Response length 48, check busy after response</p>
15–6 Reserved	<p>This read-only field is reserved and always has the value zero.</p>
5 MSBSEL	<p>Multi/Single Block Select</p> <p>This bit enables multiple block DAT line data transfers. For any other commands, this bit shall be set to 0. If this bit is 0, it is not necessary to set the block count register.</p> <p>0b Single block 1b Multiple blocks</p>
4 DTSEL	<p>Data Transfer Direction Select</p> <p>This bit defines the direction of DAT line data transfers. The bit is set to 1 by the host driver to transfer data from the SD card to the SDHC and is set to 0 for all other commands.</p>

Table continues on the next page...

SDHC_XFERTYP field descriptions (continued)

Field	Description
	0b Write (host to card) 1b Read (card to host)
3 Reserved	This read-only field is reserved and always has the value zero.
2 AC12EN	Auto CMD12 Enable Multiple block transfers for memory require a CMD12 to stop the transaction. When this bit is set to 1, the SDHC will issue a CMD12 automatically when the last block transfer has completed. The host driver shall not set this bit to issue commands that do not require CMD12 to stop a multiple block data transfer. In particular, secure commands defined in File Security Specification (see reference list) do not require CMD12. In single block transfer, the SDHC will ignore this bit no matter if it is set or not. 0b Disable 1b Enable
1 BCEN	Block Count Enable This bit is used to enable the Block Count register, which is only relevant for multiple block transfers. When this bit is 0, the internal counter for block is disabled, which is useful in executing an infinite transfer. 0b Disable 1b Enable
0 DMAEN	DMA Enable This bit enables DMA functionality. If this bit is set to 1, a DMA operation shall begin when the host driver sets the DPSEL bit of this register. Whether the simple DMA, or the advanced DMA, is active depends on the PROCTL[DMAS]. 0b Disable 1b Enable

48.4.5 Command Response 0 (SDHC_CMDRSP0)

This register is used to store part 0 of the response bits from the card.

Address: SDHC_CMDRSP0 is 400B_1000h base + 10h offset = 400B_1010h

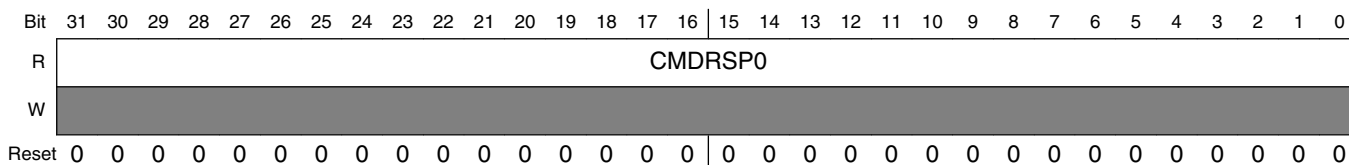

SDHC_CMDRSP0 field descriptions

Field	Description
31–0 CMDRSP0	Command Response 0

48.4.6 Command Response 1 (SDHC_CMDRSP1)

This register is used to store part 1 of the response bits from the card.

Address: SDHC_CMDRSP1 is 400B_1000h base + 14h offset = 400B_1014h

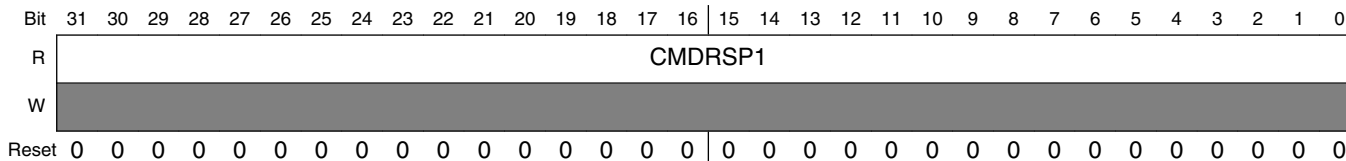

SDHC_CMDRSP1 field descriptions

Field	Description
31–0 CMDRSP1	Command Response 1

48.4.7 Command Response 2 (SDHC_CMDRSP2)

This register is used to store part 2 of the response bits from the card.

Address: SDHC_CMDRSP2 is 400B_1000h base + 18h offset = 400B_1018h

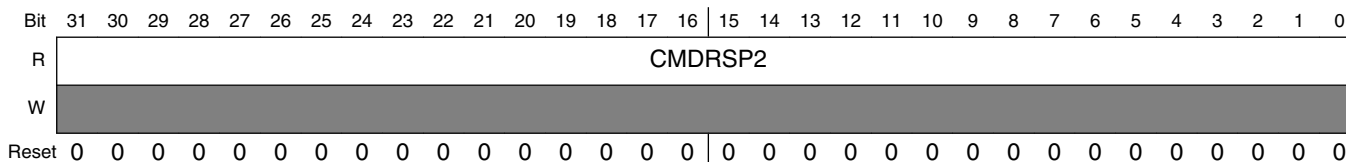

SDHC_CMDRSP2 field descriptions

Field	Description
31–0 CMDRSP2	Command Response 2

48.4.8 Command Response 3 (SDHC_CMDRSP3)

This register is used to store part 3 of the response bits from the card.

The following table describes the mapping of command responses from the SD bus to command response registers for each response type. In the table, R[] refers to a bit range within the response data as transmitted on the SD bus.

Table 48-13. Response bit definition for each response type

Response type	Meaning of response	Response field	Response register
R1,R1b (normal response)	Card status	R[39:8]	CMDRSP0
R1b (Auto CMD12 response)	Card status for auto CMD12	R[39:8]	CMDRSP3
R2 (CID, CSD register)	CID/CSD register [127:8]	R[127:8]	{CMDRSP3[23:0], CMDRSP2, CMDRSP1, CMDRSP0}
R3 (OCR register)	OCR register for memory	R[39:8]	CMDRSP0
R4 (OCR register)	OCR register for I/O etc.	R[39:8]	CMDRSP0
R5, R5b	SDIO response	R[39:8]	CMDRSP0
R6 (Publish RCA)	New published RCA[31:16] and card status[15:0]	R[39:9]	CMDRSP0

This table shows that most responses with a length of 48 (R[47:0]) have 32-bit of the response data (R[39:8]) stored in the CMDRSP0 register. Responses of type R1b (auto CMD12 responses) have response data bits (R[39:8]) stored in the CMDRSP3 register. Responses with length 136 (R[135:0]) have 120-bit of the response data (R[127:8]) stored in the CMDRSP0, 1, 2, and 3 registers.

To be able to read the response status efficiently, the SDHC only stores part of the response data in the command response registers. This enables the host driver to efficiently read 32-bit of response data in one read cycle on a 32-bit bus system. Parts of the response, the index field and the CRC, are checked by the SDHC (as specified by the XFERTYP[CICEN] and the XFERTYP[CCEN] bits) and generate an error interrupt if any error is detected. The bit range for the CRC check depends on the response length. If the response length is 48, the SDHC will check R[47:1], and if the response length is 136 the SDHC will check R[119:1].

Since the SDHC may have a multiple block data transfer executing concurrently with a CMD_wo_DAT command, the SDHC stores the auto CMD12 response in the CMDRSP3 register. The CMD_wo_DAT response is stored in CMDRSP0. This allows the SDHC to avoid overwriting the Auto CMD12 response with the CMD_wo_DAT and vice versa. When the SDHC modifies part of the command response registers, as shown in the table above, it preserves the unmodified bits.

Address: SDHC_CMDRSP3 is 400B_1000h base + 1Ch offset = 400B_101Ch

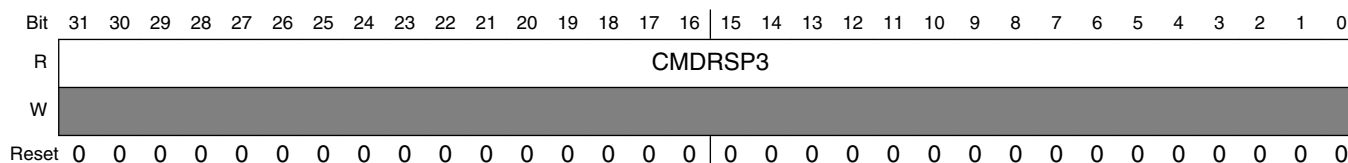

SDHC_CMDRSP3 field descriptions

Field	Description
31–0 CMDRSP3	Command Response 3

48.4.9 Buffer Data Port Register (SDHC_DATPORT)

This is a 32-bit data port register used to access the internal buffer and it can not be updated in idle mode.

Address: SDHC_DATPORT is 400B_1000h base + 20h offset = 400B_1020h

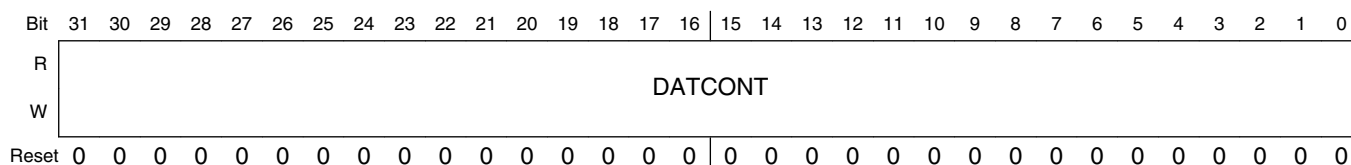

SDHC_DATPORT field descriptions

Field	Description
31–0 DATCONT	Data Content The Buffer Data Port register is for 32-bit data access by the CPU or the external DMA. When the internal DMA is enabled, any write to this register is ignored, and any read from this register will always yield 0s.

48.4.10 Present State Register (SDHC_PRSSTAT)

The host driver can get status of the SDHC from this 32-bit read only register.

NOTE

The host driver can issue CMD0, CMD12, CMD13 (for memory) and CMD52 (for SDIO) when the DAT lines are busy during a data transfer. These commands can be issued when Command Inhibit (CIHB) is set to zero. Other commands shall be issued when Command Inhibit (CDIHB) is set to zero. Possible changes to the SD Physical Specification may add other commands to this list in the future.

memory map and register definition

Address: SDHC_PRSTAT is 400B_1000h base + 24h offset = 400B_1024h

Bit	31	30	29	28	27	26	25	24	23	22	21	20	19	18	17	16
R	DLSL								CLSL	0						CINS
W																
Reset	0	0	0	0	0	0	0	0	0	0	0	0	0	0	0	0
Bit	15	14	13	12	11	10	9	8	7	6	5	4	3	2	1	0
R	0				BREN	BWEN	RTA	WTA	SDOFF	PEROFF	HCKOFF	IPGOFF	SDSTB	DLA	CDIHB	CIHB
W																
Reset	0	0	0	0	0	0	0	0	0	0	0	0	0	0	0	0

SDHC_PRSTAT field descriptions

Field	Description
31–24 DLSL	<p>DAT Line Signal Level</p> <p>This status is used to check the DAT line level to recover from errors, and for debugging. This is especially useful in detecting the busy signal level from DAT[0]. The reset value is effected by the external pullup/pulldown resistors. By default, the read value of this bit field after reset is 8'b11110111, when DAT[3] is pulled down and the other lines are pulled up.</p> <p>DAT[0] Data 0 line signal level DAT[1] Data 1 line signal level DAT[2] Data 2 line signal level DAT[3] Data 3 line signal level DAT[4] Data 4 line signal level DAT[5] Data 5 line signal level DAT[6] Data 6 line signal level DAT[7] Data 7 line signal level</p>
23 CLSL	<p>CMD Line Signal Level</p> <p>This status is used to check the CMD line level to recover from errors, and for debugging. The reset value is effected by the external pullup/pulldown resistor, by default, the read value of this bit after reset is 1b, when the command line is pulled up.</p>
22–17 Reserved	This read-only field is reserved and always has the value zero.
16 CINS	<p>Card Inserted</p> <p>This bit indicates whether a card has been inserted. The SDHC debounces this signal so that the host driver will not need to wait for it to stabilize. Changing from a 0 to 1 generates a card insertion interrupt in the interrupt status register. Changing from a 1 to 0 generates a card removal interrupt in the interrupt status register. A write to the force event register does not effect this bit.</p>

Table continues on the next page...

SDHC_PRSTAT field descriptions (continued)

Field	Description
	The SYSCTL[RSTA] does not effect this bit.A software reset does not effect this bit. 0b Power on reset or no card 1b Card inserted
15–12 Reserved	This read-only field is reserved and always has the value zero.
11 BREN	Buffer Read Enable This status bit is used for non-DMA read transfers. The SDHC may implement multiple buffers to transfer data efficiently. This read only flag indicates that valid data exists in the host side buffer. If this bit is high, valid data greater than the watermark level exist in the buffer. This read only flag indicates that valid data exists in the host side buffer. 0b Read disable, valid data less than the watermark level exist in the buffer. 1b Read enable, valid data greater than the watermark level exist in the buffer.
10 BWEN	Buffer Write Enable This status bit is used for non-DMA write transfers. The SDHC can implement multiple buffers to transfer data efficiently. This read only flag indicates if space is available for write data. If this bit is 1, valid data greater than the watermark level can be written to the buffer.This read only flag indicates if space is available for write data. 0b Write disable, the buffer can hold valid data less than the write watermark level. 1b Write enable, the buffer can hold valid data greater than the write watermark level.
9 RTA	Read Transfer Active This status bit is used for detecting completion of a read transfer. This bit is set for either of the following conditions: <ul style="list-style-type: none"> • After the end bit of the read command. • When writing a 1 to the PROCTL[CREQ] to restart a read transfer. A transfer complete interrupt is generated when this bit changes to 0. This bit is cleared for either of the following conditions: <ul style="list-style-type: none"> • When the last data block as specified by block length is transferred to the system, that is all data are read away from SDHC internal buffer. • When all valid data blocks have been transferred from SDHC internal buffer to the system and no current block transfers are being sent as a result of the stop at block gap request being set to 1. 0b No valid data 1b Transferring data
8 WTA	Write Transfer Active This status bit indicates a write transfer is active. If this bit is 0, it means no valid write data exists in the SDHC. This bit is set in either of the following cases: <ul style="list-style-type: none"> • After the end bit of the write command. • When writing 1 to the PROCTL[CREQ] to restart a write transfer. This bit is cleared in either of the following cases: <ul style="list-style-type: none"> • After getting the CRC status of the last data block as specified by the transfer count (single and multiple). • After getting the CRC status of any block where data transmission is about to be stopped by a stop at block gap request.

Table continues on the next page...

SDHC_PRSTAT field descriptions (continued)

Field	Description
	<p>During a write transaction, a block gap event interrupt is generated when this bit is changed to 0, as result of the stop at block gap request being set. This status is useful for the host driver in determining when to issue commands during write busy state.</p> <p>0b No valid data 1b Transferring data</p>
7 SDOFF	<p>SD Clock Gated Off Internally</p> <p>This status bit indicates that the SD clock is internally gated off, because of buffer over/under-run or read pause without read wait assertion, or the driver has cleared SYSCTL[SDCLKEN] bit to stop the SD clock. This bit is for the host driver to debug data transaction on the SD bus.</p> <p>0b SD clock is active 1b SD clock is gated off</p>
6 PEROFF	<p>SDHC clock Gated Off Internally</p> <p>This status bit indicates that the SDHC clock is internally gated off. This bit is for the host driver to debug transaction on the SD bus. When INITA bit is set, SDHC sending 80 clock cycles to the card, the SDCLKEN bit must be '1' to enable the output card clock, otherwise the</p> <p>SDHC clock will never be gate off, so SDHC clock and bus clock will be always active.</p> <p>0b SDHC clock is active 1b SDHC clock is gated off</p>
5 HCKOFF	<p>System Clock Gated Off Internally</p> <p>This status bit indicates that the system clock is internally gated off. This bit is for the host driver to debug during a data transfer.</p> <p>0b System clock is active 1b System clock is gated off</p>
4 IPGOFF	<p>Bus Clock Gated Off Internally</p> <p>This status bit indicates that the bus clock is internally gated off. This bit is for the host driver to debug.</p>

Table continues on the next page...

SDHC_PRSTAT field descriptions (continued)

Field	Description
	0b Bus clock is active 1b Bus clock is gated off
3 SDSTB	SD Clock Stable This status bit indicates that the internal card clock is stable. This bit is for the host driver to poll clock status when changing the clock frequency. It is recommended to clear SYSCTL[SDCLKEN] bit to remove glitch on the card clock when the frequency is changing. 0b Clock is changing frequency and not stable 1b Clock is stable
2 DLA	Data Line Active This status bit indicates whether one of the DAT lines on the SD bus is in use. In the case of read transactions: This status indicates if a read transfer is executing on the SD bus. Changes in this value from 1 to 0, between data blocks, generates a block gap event interrupt in the interrupt status register. This bit will be set in either of the following cases: <ul style="list-style-type: none"> • After the end bit of the read command. • When writing a 1 to the PROCTL[CREQ] to restart a read transfer. This bit will be cleared in either of the following cases: <ol style="list-style-type: none"> 1. When the end bit of the last data block is sent from the SD bus to the SDHC. 2. When the read wait state is stopped by a suspend command and the DAT2 line is released. The SDHC will wait at the next block gap by driving read wait at the start of the interrupt cycle. If the read wait signal is already driven (data buffer cannot receive data), the SDHC can wait for a current block gap by continuing to drive the read wait signal. It is necessary to support read wait in order to use the suspend / resume function. This bit will remain 1 during read wait. In the case of write transactions: This status indicates that a write transfer is executing on the SD bus. Changes in this value from 1 to 0 generate a transfer complete interrupt in the interrupt status register. This bit will be set in either of the following cases: <ul style="list-style-type: none"> • After the end bit of the write command. • When writing to 1 to the PROCTL[CREQ] to continue a write transfer. This bit will be cleared in either of the following cases: <ul style="list-style-type: none"> • When the SD card releases write busy of the last data block, the SDHC will also detect if the output is not busy. If the SD card does not drive the busy signal after the CRC status is received, the SDHC shall assume the card drive “Not busy”. • When the SD card releases write busy, prior to waiting for write transfer, and as a result of a stop at block gap request. In the case of command with busy pending: This status indicates that a busy state follows the command and the data line is in use. This bit will be cleared when the DAT0 line is released. 0b DAT line inactive 1b DAT line active
1 CDIHB	Command Inhibit (DAT)

Table continues on the next page...

SDHC_PRSTAT field descriptions (continued)

Field	Description
	<p>This status bit is generated if either the DLA or the RTA is set to 1. If this bit is 0, it indicates that the SDHC can issue the next SD/MMC Command. Commands with a busy signal belong to CDIHB (e.g. R1b, R5b type). Except in the case when the command busy is finished, changing from 1 to 0 generates a transfer complete interrupt in the interrupt status register.</p> <p>NOTE: The SD host driver can save registers for a suspend transaction after this bit has changed from 1 to 0.</p> <p>0b Can issue command which uses the DAT line 1b Cannot issue command which uses the DAT line</p>
0 CIHB	<p>Command Inhibit (CMD)</p> <p>If this status bit is 0, it indicates that the CMD line is not in use and the SDHC can issue a SD/MMC Command using the CMD line.</p> <p>This bit is set also immediately after the transfer type register is written. This bit is cleared when the command response is received. Even if the CDIHB bit is set to 1, Commands using only the CMD line can be issued if this bit is 0. Changing from 1 to 0 generates a command complete interrupt in the interrupt status register. If the SDHC cannot issue the command because of a command conflict error (Refer to command CRC error) or because of a command not issued by auto CMD12 error, this bit will remain 1 and the command complete is not set. The status of issuing an auto CMD12 does not show on this bit.</p> <p>0b Can issue command using only CMD line 1b Cannot issue command</p>

48.4.11 Protocol Control Register (SDHC_PROCTL)

There are three cases to restart the transfer after stop at the block gap. Which case is appropriate depends on whether the SDHC issues a suspend command or the SD card accepts the suspend command.

1. If the host driver does not issue a suspend command, the continue request shall be used to restart the transfer.
2. If the host driver issues a suspend command and the SD card accepts it, a resume command shall be used to restart the transfer.
3. If the host driver issues a suspend command and the SD card does not accept it, the continue request shall be used to restart the transfer.

Any time stop at block gap request stops the data transfer, the host driver shall wait for a transfer complete (in the interrupt status register), before attempting to restart the transfer. When restarting the data transfer by continue request, the host driver shall clear the stop at block gap request before or simultaneously.

Address: SDHC_PROCTL is 400B_1000h base + 28h offset = 400B_1028h

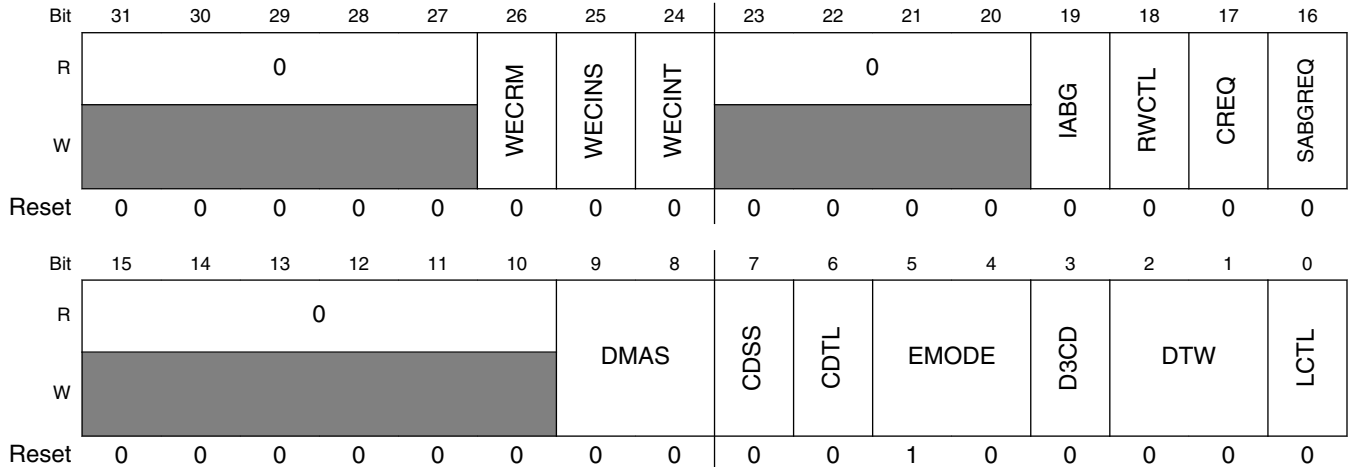

SDHC_PROCTL field descriptions

Field	Description
31–27 Reserved	This read-only field is reserved and always has the value zero.
26 WECRM	<p>Wakeup Event Enable On SD Card Removal</p> <p>This bit enables a wakeup event, via IRQSTAT[CRM]. FN_WUS (Wake Up Support) in CIS does not effect this bit. When this bit is set, the IRQSTAT[CRM] and the SDHC interrupt can be asserted without SD_CLK toggling. When the wakeup feature is not enabled, the SD_CLK must be active in order to assert the IRQSTAT[CRM] and the SDHC interrupt.</p> <p>0b Disabled 1b Enabled</p>
25 WECINS	<p>Wakeup Event Enable On SD Card Insertion</p> <p>This bit enables a wakeup event, via IRQSTAT[CINS]. FN_WUS (Wake Up Support) in CIS does not effect this bit. When this bit is set, the IRQSTATEN[CINSEN] and the SDHC interrupt can be asserted without SD_CLK toggling. When the wakeup feature is not enabled, the SD_CLK must be active in order to assert the IRQSTATEN[CINSEN] and the SDHC interrupt.</p> <p>0b Disabled 1b Enabled</p>
24 WECINT	<p>Wakeup Event Enable On Card Interrupt</p> <p>This bit enables a wakeup event, via IRQSTAT[CINT]. This bit can be set to 1 if FN_WUS (Wake Up Support) in CIS is set to 1. When this bit is set, the card interrupt status and the SDHC interrupt can be asserted without SD_CLK toggling. When the wakeup feature is not enabled, the SD_CLK must be active in order to assert the card interrupt status and the SDHC interrupt.</p> <p>0b Disabled 1b Enabled</p>
23–20 Reserved	This read-only field is reserved and always has the value zero.
19 IABG	Interrupt At Block Gap

Table continues on the next page...

SDHC_PROCTL field descriptions (continued)

Field	Description
	<p>This bit is valid only in 4-bit mode, of the SDIO card, and selects a sample point in the interrupt cycle. Setting to 1 enables interrupt detection at the block gap for a multiple block transfer. Setting to 0 disables interrupt detection during a multiple block transfer. If the SDIO card can't signal an interrupt during a multiple block transfer, this bit should be set to 0 to avoid an inadvertent interrupt. When the host driver detects an SDIO card insertion, it shall set this bit according to the CCCR of the card.</p> <p>0b Disabled 1b Enabled</p>
18 RWCTL	<p>Read Wait Control</p> <p>The read wait function is optional for SDIO cards. If the card supports read wait, set this bit to enable use of the read wait protocol to stop read data using the DAT[2] line. Otherwise the SDHC has to stop the SD Clock to hold read data, which restricts commands generation. When the host driver detects an SDIO card insertion, it shall set this bit according to the CCCR of the card. If the card does not support read wait, this bit shall never be set to 1, otherwise DAT line conflicts may occur. If this bit is set to 0, stop at block gap during read operation is also supported, but the SDHC will stop the SD Clock to pause reading operation.</p> <p>0b Disable read wait control, and stop SD clock at block gap when SABGREQ bit is set. 1b Enable read wait control, and assert read wait without stopping SD clock at block gap when SABGREQ bit is set.</p>
17 CREQ	<p>Continue Request</p> <p>This bit is used to restart a transaction which was stopped using the PROCTL[SABGREQ]. When a suspend operation is not accepted by the card, it is also by setting this bit to restart the paused transfer. To cancel stop at the block gap, set PROCTL[SABGREQ] to 0 and set this bit to 1 to restart the transfer.</p> <p>The SDHC automatically clears this bit, therefore it is not necessary for the host driver to set this bit to 0. If both PROCTL[SABGREQ] and this bit are 1, the continue request is ignored.</p> <p>0b No effect 1b Restart</p>
16 SABGREQ	<p>Stop At Block Gap Request</p> <p>This bit is used to stop executing a transaction at the next block gap for both DMA and non-DMA transfers. Until the IRQSTATEN[TCSEN] is set to 1, indicating a transfer completion, the host driver shall leave this bit set to 1. Clearing both the PROCTL[SABGREQ] and PROCTL[CREQ] does not cause the transaction to restart. Read Wait is used to stop the read transaction at the block gap. The SDHC will honor the PROCTL[SABGREQ] for write transfers, but for read transfers it requires that the SDIO card support read wait. Therefore, the host driver shall not set this bit during read transfers unless the SDIO card supports read wait and has set the PROCTL[RWCTL] to 1, otherwise the SDHC will stop the SD bus clock to pause the read operation during block gap. In the case of write transfers in which the host driver writes data to the data port register, the host driver shall set this bit after all block data is written. If this bit is set to 1, the host driver shall not write data to the data port register after a block is sent. Once this bit is set, the host driver shall not clear this bit before the IRQSTATEN[TCSEN] is set, otherwise the SDHC's behavior is undefined.</p> <p>This bit effects PRSSTAT[RTA], PRSSTAT[WTA], PRSSTAT[CDIHB].</p> <p>0b Transfer 1b Stop</p>
15–10 Reserved	<p>This read-only field is reserved and always has the value zero.</p>

Table continues on the next page...

SDHC_PROCTL field descriptions (continued)

Field	Description
9–8 DMAS	<p>DMA Select</p> <p>This field is valid while DMA (SDMA or ADMA) is enabled and selects the DMA operation.</p> <p>00 No DMA or simple DMA is selected 01 ADMA1 is selected 10 ADMA2 is selected 11 Reserved</p>
7 CDSS	<p>Card Detect Signal Selection</p> <p>This bit selects the source for the card detection.</p> <p>0b Card detection level is selected (for normal purpose) 1b Card detection test level is selected (for test purpose)</p>
6 CDTL	<p>Card Detect Test Level</p> <p>This bit is enabled while the CDSS is set to 1 and it indicates card insertion.</p> <p>0b Card detect test level is 0, no card inserted 1b Card detect test level is 1, card inserted</p>
5–4 EMODE	<p>Endian Mode</p> <p>The SDHC supports all four endian modes in data transfer.</p> <p>00b Big endian mode 01b Half word big endian mode 10b Little endian mode 11b Reserved</p>
3 D3CD	<p>DAT3 as Card Detection Pin</p> <p>If this bit is set, DAT3 should be pulled down to act as a card detection pin. Be cautious when using this feature, because DAT3 is also a chip-select for the SPI mode. A pulldown on this pin and CMD0 may set the card into the SPI mode, which the SDHC does not support. Note: Keep this bit set if SDIO interrupt is used.</p> <p>0b DAT3 does not monitor card Insertion 1b DAT3 as card detection pin</p>
2–1 DTW	<p>Data Transfer Width</p> <p>This bit selects the data width of the SD bus for a data transfer. The host driver shall set it to match the data width of the card. Possible data transfer width is 1-bit, 4-bits or 8-bits.</p> <p>00b 1-bit mode 01b 4-bit mode 10b 8-bit mode 11b Reserved</p>
0 LCTL	<p>LED Control</p> <p>This bit, fully controlled by the host driver, is used to caution the user not to remove the card while the card is being accessed. If the software is going to issue multiple SD commands, this bit can be set during</p>

Table continues on the next page...

SDHC_PROCTL field descriptions (continued)

Field	Description
	all these transactions. It is not necessary to change for each transaction. When the software issues multiple SD commands, setting the bit once before the first command is sufficient: it is not necessary to reset the bit between commands.
0b	LED off
1b	LED on

48.4.12 System Control Register (SDHC_SYSCTL)

Address: SDHC_SYSCTL is 400B_1000h base + 2Ch offset = 400B_102Ch

Bit	31	30	29	28	27	26	25	24	23	22	21	20	19	18	17	16
R	0				INITA	0	0	0	0				DTCV			
W						RSTD	RSTC	RSTA								
Reset	0	0	0	0	0	0	0	0	0	0	0	0	0	0	0	0
Bit	15	14	13	12	11	10	9	8	7	6	5	4	3	2	1	0
R	SDCLKFS								DVS				SDCLKEN	PEREN	HCKEN	IPGEN
W																
Reset	1	0	0	0	0	0	0	0	0	0	0	0	1	0	0	0

SDHC_SYSCTL field descriptions

Field	Description
31–28 Reserved	This read-only field is reserved and always has the value zero.
27 INITA	<p>Initialization Active</p> <p>When this bit is set, 80 SD-clocks are sent to the card. After the 80 clocks are sent, this bit is self cleared. This bit is very useful during the card power-up period when 74 SD-clocks are needed and the clock auto gating feature is enabled. Writing 1 to this bit when this bit is already 1 has no effect. Writing 0 to this bit at any time has no effect. When either of the PRSSTAT[CIHB] and PRSSTAT[CDIHB] bits are set, writing 1 to this bit is ignored (i.e. when command line or data lines are active, write to this bit is not allowed). On the otherhand, when this bit is set, i.e., during initialization active period, it is allowed to issue command, and the command bit stream will appear on the CMD pad after all 80 clock cycles are done. So when this command ends, the driver can make sure the 80 clock cycles are sent out. This is very useful when the driver needs send 80 cycles to the card and does not want to wait till this bit is self cleared.</p>
26 RSTD	<p>Software Reset For DAT Line</p> <p>Only part of the data circuit is reset. DMA circuit is also reset. The following registers and bits are cleared by this bit:</p> <ul style="list-style-type: none"> • Data port register • Buffer is cleared and initialized.Present State register • Buffer Read Enable

Table continues on the next page...

SDHC_SYSCTL field descriptions (continued)

Field	Description
	<ul style="list-style-type: none"> • Buffer Write Enable • Read Transfer Active • Write Transfer Active • DAT Line Active • Command Inhibit (DAT) Protocol Control register • Continue Request • Stop At Block Gap Request Interrupt Status register • Buffer Read Ready • Buffer Write Ready • DMA Interrupt • Block Gap Event • Transfer Complete <p>0b No reset 1b Reset</p>
25 RSTC	Software Reset For CMD Line Only part of the command circuit is reset. The following registers and bits are cleared by this bit: <ul style="list-style-type: none"> • PRSSTAT[CIHB] • IRQSTAT[CC] <p>0b No reset 1b Reset</p>
24 RSTA	Software Reset For ALL This reset effects the entire host controller except for the card detection circuit. Register bits of type ROC, RW, RW1C, RWAC are cleared. During its initialization, the host driver shall set this bit to 1 to reset the SDHC. The SDHC shall reset this bit to 0 when the capabilities registers are valid and the host driver can read them. Additional use of software reset for all does not affect the value of the capabilities registers. After this bit is set, it is recommended that the host driver reset the external card and re-initialize it. <p>0b No reset 1b Reset</p>
23–20 Reserved	This read-only field is reserved and always has the value zero.
19–16 DTCV	Data Timeout Counter Value This value determines the interval by which DAT line timeouts are detected. Refer to the IRQSTAT[DTOE] for information on factors that dictate time-out generation. Time-out clock frequency will be generated by dividing the base clock SDCLK value by this value. The host driver can clear the IRQSTATEN[DTOESN] to prevent inadvertent time-out events. <p>0000b SDCLK x 2¹³ 0001b SDCLK x 2¹⁴ ... 1110b SDCLK x 2²⁷ 1111b Reserved</p>
15–8 SDCLKFS	SDCLK Frequency Select This register is used to select the frequency of the SDCLK pin. The frequency is not programmed directly, rather this register holds the prescaler (this register) and divisor (next register) of the base clock frequency register.

Table continues on the next page...

SDHC_SYSCTL field descriptions (continued)

Field	Description
	<p>Setting 00h bypasses the frequency prescaler of the SD Clock. Multiple bits must not be set, or the behavior of this prescaler is undefined. The two default divider values can be calculated by the frequency of SDHC clock and the following divisor bits.</p> <p>The frequency of SDCLK is set by the following formula: Clock frequency = (Base clock) / (prescaler x divisor)</p> <p>For example, if the base clock frequency is 96 MHz, and the target frequency is 25 MHz, then choosing the prescaler value of 01h and divisor value of 1h will yield 24 MHz, which is the nearest frequency less than or equal to the target. Similarly, to approach a clock value of 400 kHz, the prescaler value of 08h and divisor value of eh yields the exact clock value of 400 kHz. The reset value of this bit field is 80h, so if the input base clock (SDHC clock) is about 96 MHz, the default SD clock after reset is 375 kHz.</p> <p>According to the SD Physical Specification Version 1.1 and the SDIO Card Specification Version 1.2, the maximum SD clock frequency is 50 MHz and shall never exceed this limit.</p> <p>Only the following settings are allowed:</p> <p>01h Base clock divided by 2 02h Base clock divided by 4 04h Base clock divided by 8 08h Base clock divided by 16 10h Base clock divided by 32 20h Base clock divided by 64 40h Base clock divided by 128 80h Base clock divided by 256</p>
7-4 DVS	<p>Divisor</p> <p>This register is used to provide a more exact divisor to generate the desired SD clock frequency. Note the divider can even support odd divisor without deterioration of duty cycle.</p> <p>The setting are as following:</p> <p>0h Divisor by 1 1h Divisor by 2 ... Eh Divisor by 15 Fh Divisor by 16</p>
3 SDCLKEN	<p>SD Clock Enable</p> <p>The host controller shall stop SDCLK when writing this bit to 0. SDCLK frequency can be changed when this bit is 0. Then, the host controller shall maintain the same clock frequency until SDCLK is stopped (stop at SDCLK = 0). If the IRQSTAT[CINS] is cleared, this bit should be cleared by the host driver to save power.</p>
2 PEREN	<p>Peripheral Clock Enable</p> <p>If this bit is set, SDHC clock will always be active and no automatic gating is applied. Thus the SDCLK is active except for when auto gating-off during buffer danger (buffer about to over-run or under-run). When this bit is cleared, the SDHC clock will be automatically off whenever there is no transaction on the SD bus. Since this bit is only a feature enabling bit, clearing this bit does not stop SDCLK immediately. The SDHC clock will be internally gated off, if none of the following factors are met:</p> <ul style="list-style-type: none"> • The cmd part is reset, or • Data part is reset, or • A soft reset, or • The cmd is about to send, or • Clock divisor is just updated, or

Table continues on the next page...

SDHC_SYSCTL field descriptions (continued)

Field	Description
	<ul style="list-style-type: none"> • Continue request is just set, or • This bit is set, or • Card insertion is detected, or • Card removal is detected, or • Card external interrupt is detected, or • 80 clocks for initialization phase is ongoing <p>0b SDHC clock will be internally gated off 1b SDHC clock will not be automatically gated off</p>
<p>1 HCKEN</p>	<p>System Clock Enable</p> <p>If this bit is set, system clock will always be active and no automatic gating is applied. When this bit is cleared, system clock will be automatically off when no data transfer is on the SD bus.</p> <p>0b System clock will be internally gated off 1b System clock will not be automatically gated off</p>
<p>0 IPGEN</p>	<p>IPG Clock Enable</p> <p>If this bit is set, bus clock will always be active and no automatic gating is applied. The bus clock will be internally gated off, if none of the following factors are met:</p> <ul style="list-style-type: none"> • The cmd part is reset, or • Data part is reset, or • Soft reset, or • The cmd is about to send, or • Clock divisor is just updated, or • Continue request is just set, or • This bit is set, or • Card insertion is detected, or • Card removal is detected, or • Card external interrupt is detected, or • The SDHC clock is not gated off <p>NOTE: The bus clock will not be auto gated off if the SDHC clock is not gated off. So clearing only this bit has no effect unless the PEREN bit is also cleared.</p> <p>0b Bus clock will be internally gated off 1b Bus clock will not be automatically gated off</p>

48.4.13 Interrupt Status Register (SDHC_IRQSTAT)

An interrupt is generated when the Normal Interrupt Signal Enable is enabled and at least one of the status bits is set to 1. For all bits, writing 1 to a bit clears it; writing to 0 keeps the bit unchanged. More than one status can be cleared with a single register write. For Card Interrupt, before writing 1 to clear, it is required that the card stops asserting the interrupt, meaning that when the Card Driver services the interrupt condition, otherwise the CINT bit will be asserted again.

The table below shows the relationship between the CTOE and the CC bits.

Table 48-19. SDHC status for CTOE/CC bit combinations

Command complete	Command timeout error	Meaning of the status
0	0	X
X	1	Response not received within 64 SDCLK cycles
1	0	Response received

The table below shows the relationship between the Transfer Complete and the Data Timeout Error.

Table 48-20. SDHC status for data timeout error/transfer complete bit combinations

Transfer complete	Data timeout error	Meaning of the status
0	0	X
0	1	Timeout occurred during transfer
1	X	Data transfer complete

The table below shows the relationship between the command CRC error (CCE) and command timeout error (CTOE).

Table 48-21. SDHC status for CCE/CTOE Bit Combinations

Command complete	Command timeout error	Meaning of the status
0	0	No error
0	1	Response timeout error
1	0	Response CRC error
1	1	CMD line conflict

Address: SDHC_IRQSTAT is 400B_1000h base + 30h offset = 400B_1030h

Bit	31	30	29	28	27	26	25	24	23	22	21	20	19	18	17	16	
R	0			DMAE	0			AC12E	0	DEBE	DCE	DTOE	CIE	CEBE	CCE	CTOE	
W	w1c			w1c	w1c			w1c	w1c	w1c	w1c	w1c	w1c	w1c	w1c	w1c	
Reset	0	0	0	0	0	0	0	0	0	0	0	0	0	0	0	0	
Bit	15	14	13	12	11	10	9	8	7	6	5	4	3	2	1	0	
R	0							CINT	CRM	CINS	BRR	BWR	DINT	BGE	TC	CC	
W	w1c							w1c	w1c	w1c	w1c	w1c	w1c	w1c	w1c	w1c	w1c
Reset	0	0	0	0	0	0	0	0	0	0	0	0	0	0	0	0	

SDHC_IRQSTAT field descriptions

Field	Description
31–29 Reserved	This read-only field is reserved and always has the value zero.
28 DMAE	<p>DMA Error</p> <p>Occurs when an Internal DMA transfer has failed. This bit is set to 1, when some error occurs in the data transfer. This error can be caused by either Simple DMA or ADMA, depending on which DMA is in use. The value in DMA System Address register is the next fetch address where the error occurs. Since any error corrupts the whole data block, the host driver shall re-start the transfer from the corrupted block boundary. The address of the block boundary can be calculated either from the current DSADDR value or from the remaining number of blocks and the block size.</p> <p>0b No Error 1b Error</p>
27–25 Reserved	This read-only field is reserved and always has the value zero.
24 AC12E	<p>Auto CMD12 Error</p> <p>Occurs when detecting that one of the bits in the Auto CMD12 Error Status register has changed from 0 to 1. This bit is set to 1, not only when the errors in Auto CMD12 occur, but also when the Auto CMD12 is not executed due to the previous command error.</p> <p>0b No Error 1b Error</p>
23 Reserved	This read-only field is reserved and always has the value zero.
22 DEBE	<p>Data End Bit Error</p> <p>Occurs either when detecting 0 at the end bit position of read data, which uses the DAT line, or at the end bit position of the CRC.</p>

Table continues on the next page...

SDHC_IRQSTAT field descriptions (continued)

Field	Description
	0b No Error 1b Error
21 DCE	Data CRC Error Occurs when detecting a CRC error when transferring read data, which uses the DAT line, or when detecting the Write CRC status having a value other than 010. 0b No Error 1b Error
20 DTOE	Data Timeout Error Occurs when detecting one of following time-out conditions. <ul style="list-style-type: none"> • Busy time-out for R1b,R5b type • Busy time-out after Write CRC status • Read Data time-out 0b No Error 1b Time out
19 CIE	Command Index Error Occurs if a Command Index error occurs in the command response. 0b No Error 1b Error
18 CEBE	Command End Bit Error Occurs when detecting that the end bit of a command response is 0. 0b No Error 1b End Bit Error Generated
17 CCE	Command CRC Error Command CRC Error is generated in two cases. <ul style="list-style-type: none"> • If a response is returned and the Command Timeout Error is set to 0 (indicating no time-out), this bit is set when detecting a CRC error in the command response. • The SDHC detects a CMD line conflict by monitoring the CMD line when a command is issued. If the SDHC drives the CMD line to 1, but detects 0 on the CMD line at the next SDCLK edge, then the SDHC shall abort the command (Stop driving CMD line) and set this bit to 1. The Command Timeout Error shall also be set to 1 to distinguish CMD line conflict. 0b No Error 1b CRC Error Generated
16 CTOE	Command Timeout Error Occurs only if no response is returned within 64 SDCLK cycles from the end bit of the command. If the SDHC detects a CMD line conflict, in which case a Command CRC Error shall also be set, this bit shall be set without waiting for 64 SDCLK cycles. This is because the command will be aborted by the SDHC. 0b No Error 1b Time out

Table continues on the next page...

SDHC_IRQSTAT field descriptions (continued)

Field	Description
15–9 Reserved	This read-only field is reserved and always has the value zero.
8 CINT	<p>Card Interrupt</p> <p>This status bit is set when an interrupt signal is detected from the external card. In 1-bit mode, the SDHC will detect the Card Interrupt without the SD Clock to support wakeup. In 4-bit mode, the card interrupt signal is sampled during the interrupt cycle, so the interrupt from card can only be sampled during interrupt cycle, introducing some delay between the interrupt signal from the SDIO card and the interrupt to the host system. Writing this bit to 1 can clear this bit, but as the interrupt factor from the SDIO card does not clear, this bit is set again. In order to clear this bit, it is required to reset the interrupt factor from the external card followed by a writing 1 to this bit.</p> <p>When this status has been set, and the host driver needs to service this interrupt, the Card Interrupt Signal Enable in the Interrupt Signal Enable register should be 0 to stop driving the interrupt signal to the host system. After completion of the card interrupt service (It should reset the interrupt factors in the SDIO card and the interrupt signal may not be asserted), write 1 to clear this bit, set the Card Interrupt Signal Enable to 1, and start sampling the interrupt signal again.</p> <p>0b No Card Interrupt 1b Generate Card Interrupt</p>
7 CRM	<p>Card Removal</p> <p>This status bit is set if the Card Inserted bit in the Present State register changes from 1 to 0. When the host driver writes this bit to 1 to clear this status, the status of the Card Inserted in the Present State register should be confirmed. Because the card state may possibly be changed when the host driver clears this bit and the interrupt event may not be generated. When this bit is cleared, it will be set again if no card is inserted. In order to leave it cleared, clear the Card Removal Status Enable bit in Interrupt Status Enable register.</p> <p>0b Card state unstable or inserted 1b Card removed</p>
6 CINS	<p>Card Insertion</p> <p>This status bit is set if the Card Inserted bit in the Present State register changes from 0 to 1. When the host driver writes this bit to 1 to clear this status, the status of the Card Inserted in the Present State register should be confirmed. Because the card state may possibly be changed when the host driver clears this bit and the interrupt event may not be generated. When this bit is cleared, it will be set again if a card is inserted. In order to leave it cleared, clear the Card Inserted Status Enable bit in Interrupt Status Enable register.</p> <p>0b Card state unstable or removed 1b Card inserted</p>
5 BRR	<p>Buffer Read Ready</p> <p>This status bit is set if the Buffer Read Enable bit, in the Present State register, changes from 0 to 1. Refer to the Buffer Read Enable bit in the Present State register for additional information.</p> <p>0b Not ready to read buffer 1b Ready to read buffer</p>
4 BWR	<p>Buffer Write Ready</p> <p>This status bit is set if the Buffer Write Enable bit, in the Present State register, changes from 0 to 1. Refer to the Buffer Write Enable bit in the Present State register for additional information.</p>

Table continues on the next page...

SDHC_IRQSTAT field descriptions (continued)

Field	Description
	<p>0b Not ready to write buffer 1b Ready to write buffer</p>
3 DINT	<p>DMA Interrupt</p> <p>Occurs only when the internal DMA finishes the data transfer successfully. Whenever errors occur during data transfer, this bit will not be set. Instead, the DMAE bit will be set. Either Simple DMA or ADMA finishes data transferring, this bit will be set.</p> <p>0b No DMA Interrupt 1b DMA Interrupt is generated</p>
2 BGE	<p>Block Gap Event</p> <p>If the PROCTL[SABGREQ] is set, this bit is set when a read or write transaction is stopped at a block gap. If PROCTL[SABGREQ] is not set to 1, this bit is not set to 1.</p> <p>In the case of a read transaction: This bit is set at the falling edge of the DAT line active status (When the transaction is stopped at SD Bus timing). The read wait must be supported in order to use this function.</p> <p>In the case of write transaction: This bit is set at the falling edge of write transfer active status (After getting CRC status at SD bus timing).</p> <p>0b No block gap event 1b Transaction stopped at block gap</p>
1 TC	<p>Transfer Complete</p> <p>This bit is set when a read or write transfer is completed.</p> <p>In the case of a read transaction: This bit is set at the falling edge of the read transfer active status. There are two cases in which this interrupt is generated. The first is when a data transfer is completed as specified by the data length (after the last data has been read to the host system). The second is when data has stopped at the block gap and completed the data transfer by setting the PROCTL[SABGREQ] (after valid data has been read to the host system).</p> <p>In the case of a write transaction: This bit is set at the falling edge of the DAT line active status. There are two cases in which this interrupt is generated. The first is when the last data is written to the SD card as specified by the data length and the busy signal is released. The second is when data transfers are stopped at the block gap, by setting the PROCTL[SABGREQ], and the data transfers are completed. (after valid data is written to the SD card and the busy signal released).</p> <p>0b Transfer not complete 1b Transfer complete</p>
0 CC	<p>Command Complete</p> <p>This bit is set when you receive the end bit of the command response (except Auto CMD12). Refer to the PRSSTAT[CIHB].</p> <p>0b Command not complete 1b Command complete</p>

48.4.14 Interrupt Status Enable Register (SDHC_IRQSTATEN)

Setting the bits in this register to 1 enables the corresponding interrupt status to be set by the specified event. If any bit is cleared, the corresponding interrupt status bit is also cleared (i.e. when the bit in this register is cleared, the corresponding bit in interrupt status register is always 0).

NOTE

- Depending on PROCTL[IABG] bit setting, SDHC may be programmed to sample the card interrupt signal during the interrupt period and hold its value in the flip-flop. There will be some delays on the card interrupt, asserted from the card, to the time the host system is informed.
- To detect a CMD line conflict, the host driver must set both IRQSTATEN[CTOESEN] and IRQSTATEN[CCESSEN] to 1.

Address: SDHC_IRQSTATEN is 400B_1000h base + 34h offset = 400B_1034h

Bit	31	30	29	28	27	26	25	24	23	22	21	20	19	18	17	16
R	0			DMAESEN	0			AC12ESEN	0	DEBESEN	DCESEN	DTOESEN	CIESEN	CEBESEN	CCESSEN	CTOESEN
W	[Masked]			DMAESEN	[Masked]			AC12ESEN	[Masked]	DEBESEN	DCESEN	DTOESEN	CIESEN	CEBESEN	CCESSEN	CTOESEN
Reset	0	0	0	1	0	0	0	1	0	1	1	1	1	1	1	1
Bit	15	14	13	12	11	10	9	8	7	6	5	4	3	2	1	0
R	0							CINTSEN	CRMSSEN	CINSEN	BRRSEN	BWRSEN	DINTSEN	BGESEN	TCSEN	CCSEN
W	[Masked]							CINTSEN	CRMSSEN	CINSEN	BRRSEN	BWRSEN	DINTSEN	BGESEN	TCSEN	CCSEN
Reset	0	0	0	0	0	0	0	1	0	0	1	1	1	1	1	1

SDHC_IRQSTATEN field descriptions

Field	Description
31–29 Reserved	This read-only field is reserved and always has the value zero.
28 DMAESEN	DMA Error Status Enable 0b Masked 1b Enabled
27–25 Reserved	This read-only field is reserved and always has the value zero.

Table continues on the next page...

SDHC_IRQSTATEN field descriptions (continued)

Field	Description
24 AC12ESEN	Auto CMD12 Error Status Enable 0b Masked 1b Enabled
23 Reserved	This read-only field is reserved and always has the value zero.
22 DEBESEN	Data End Bit Error Status Enable 0b Masked 1b Enabled
21 DCESEN	Data CRC Error Status Enable 0b Masked 1b Enabled
20 DTESEN	Data Timeout Error Status Enable 0b Masked 1b Enabled
19 CIESEN	Command Index Error Status Enable 0b Masked 1b Enabled
18 CEBESEN	Command End Bit Error Status Enable 0b Masked 1b Enabled
17 CCESEN	Command CRC Error Status Enable 0b Masked 1b Enabled
16 CTESEN	Command Timeout Error Status Enable 0b Masked 1b Enabled
15–9 Reserved	This read-only field is reserved and always has the value zero.
8 CINTSEN	Card Interrupt Status Enable If this bit is set to 0, the SDHC will clear the interrupt request to the system. The card interrupt detection is stopped when this bit is cleared and restarted when this bit is set to 1. The host driver should clear the this bit before servicing the card interrupt and should set this bit again after all interrupt requests from the card are cleared to prevent inadvertent interrupts. 0b Masked 1b Enabled
7 CRMSEN	Card Removal Status Enable

Table continues on the next page...

SDHC_IRQSTATEN field descriptions (continued)

Field	Description
	0b Masked 1b Enabled
6 CINSEN	Card Insertion Status Enable 0b Masked 1b Enabled
5 BRRSEN	Buffer Read Ready Status Enable 0b Masked 1b Enabled
4 BWRSEN	Buffer Write Ready Status Enable 0b Masked 1b Enabled
3 DINTSEN	DMA Interrupt Status Enable 0b Masked 1b Enabled
2 BGESEN	Block Gap Event Status Enable 0b Masked 1b Enabled
1 TCSEN	Transfer Complete Status Enable 0b Masked 1b Enabled
0 CCSEN	Command Complete Status Enable 0b Masked 1b Enabled

48.4.15 Interrupt Signal Enable Register (SDHC_IRQSIGEN)

This register is used to select which interrupt status is indicated to the host system as the interrupt. These status bits all share the same interrupt line. Setting any of these bits to 1 enables interrupt generation. The corresponding status register bit will generate an interrupt when the corresponding interrupt signal enable bit is set.

Address: SDHC_IRQSIGEN is 400B_1000h base + 38h offset = 400B_1038h

Bit	31	30	29	28	27	26	25	24	23	22	21	20	19	18	17	16
R	0			DMAEIEN	0			AC12EIEN	0	DEBEIEN	DCEIEN	DTOEIEN	CIEIEN	CEBEIEN	CCEIEN	CTOEIEN
W	[Masked]			[Masked]	[Masked]			[Masked]	[Masked]	[Masked]	[Masked]	[Masked]	[Masked]	[Masked]	[Masked]	[Masked]
Reset	0	0	0	0	0	0	0	0	0	0	0	0	0	0	0	0
Bit	15	14	13	12	11	10	9	8	7	6	5	4	3	2	1	0
R	0							CINTIEN	CRMIEN	CINSIEN	BRIIEN	BWRIEN	DINTIEN	BGEIEN	TCIEN	CCIEN
W	[Masked]							[Masked]	[Masked]	[Masked]	[Masked]	[Masked]	[Masked]	[Masked]	[Masked]	[Masked]
Reset	0	0	0	0	0	0	0	0	0	0	0	0	0	0	0	0

SDHC_IRQSIGEN field descriptions

Field	Description
31–29 Reserved	This read-only field is reserved and always has the value zero.
28 DMAEIEN	DMA Error Interrupt Enable 0b Masked 1b Enabled
27–25 Reserved	This read-only field is reserved and always has the value zero.
24 AC12EIEN	Auto CMD12 Error Interrupt Enable 0b Masked 1b Enabled
23 Reserved	This read-only field is reserved and always has the value zero.
22 DEBEIEN	Data End Bit Error Interrupt Enable 0b Masked 1b Enabled
21 DCEIEN	Data CRC Error Interrupt Enable

Table continues on the next page...

SDHC_IRQSIGEN field descriptions (continued)

Field	Description
	0b Masked 1b Enabled
20 DTOEIEIN	Data Timeout Error Interrupt Enable 0b Masked 1b Enabled
19 CIEIEIN	Command Index Error Interrupt Enable 0b Masked 1b Enabled
18 CEBEIEIN	Command End Bit Error Interrupt Enable 0b Masked 1b Enabled
17 CCEIEIN	Command CRC Error Interrupt Enable 0b Masked 1b Enabled
16 CTOEIEIN	Command Timeout Error Interrupt Enable 0b Masked 1b Enabled
15–9 Reserved	This read-only field is reserved and always has the value zero.
8 CINTIEIN	Card Interrupt Enable 0b Masked 1b Enabled
7 CRMIEN	Card Removal Interrupt Enable 0b Masked 1b Enabled
6 CINSIEN	Card Insertion Interrupt Enable 0b Masked 1b Enabled
5 BRRIEN	Buffer Read Ready Interrupt Enable 0b Masked 1b Enabled
4 BWRIEN	Buffer Write Ready Interrupt Enable 0b Masked 1b Enabled
3 DINTIEIN	DMA Interrupt Enable

Table continues on the next page...

SDHC_IRQSIGEN field descriptions (continued)

Field	Description
	0b Masked 1b Enabled
2 BGEIEN	Block Gap Event Interrupt Enable 0b Masked 1b Enabled
1 TCIEN	Transfer Complete Interrupt Enable 0b Masked 1b Enabled
0 CCIEN	Command Complete Interrupt Enable 0b Masked 1b Enabled

48.4.16 Auto CMD12 Error Status Register (SDHC_AC12ERR)

When the AC12ESEN bit in the Status register is set, the host driver shall check this register to identify what kind of error the Auto CMD12 indicated. This register is valid only when the Auto CMD12 Error status bit is set.

The following table shows the relationship between the Auto CMGD12 CRC error and the Auto CMD12 command timeout error.

Table 48-25. Relationship Between Command CRC Error and Command Timeout Error for Auto CMD12

Auto CMD12 CRC error	Auto CMD12 timeout error	Type of error
0	0	No error
0	1	Response timeout error
1	0	Response CRC error
1	1	CMD line conflict

Changes in Auto CMD12 Error Status register can be classified in three scenarios:

1. When the SDHC is going to issue an auto CMD12.
 - Set bit 0 to 1 if the auto CMD12 can't be issued due to an error in the previous command.
 - Set bit 0 to 0 if the auto CMD12 is issued.
2. At the end bit of an auto CMD12 response.

- Check errors correspond to bits 1-4.
 - Set bits 1-4 corresponding to detected errors.
 - Clear bits 1-4 corresponding to detected errors.
3. Before reading the auto CMD12 error status bit 7.
- Set bit 7 to 1 if there is a command that can't be issued.
 - Clear bit 7 if there is no command to issue.

The timing for generating the auto CMD12 error and writing to the command register are asynchronous. After that, bit 7 shall be sampled when the driver is not writing to the command register. So it is suggested to read this register only when the IRQSTAT[AC12E] is set. An Auto CMD12 error interrupt is generated when one of the error bits (0-4) is set to 1. The command not issued by auto CMD12 error does not generate an interrupt.

Address: SDHC_AC12ERR is 400B_1000h base + 3Ch offset = 400B_103Ch

Bit	31	30	29	28	27	26	25	24	23	22	21	20	19	18	17	16
R	0															
W	[Greyed out]															
Reset	0	0	0	0	0	0	0	0	0	0	0	0	0	0	0	0
Bit	15	14	13	12	11	10	9	8	7	6	5	4	3	2	1	0
R	0								CNIBAC12E	0		AC12IE	AC12CE	AC12EBE	AC12TOE	AC12NE
W	[Greyed out]															
Reset	0	0	0	0	0	0	0	0	0	0	0	0	0	0	0	0

SDHC_AC12ERR field descriptions

Field	Description
31–8 Reserved	This read-only field is reserved and always has the value zero.

Table continues on the next page...

SDHC_AC12ERR field descriptions (continued)

Field	Description
7 CNIBAC12E	<p>Command Not Issued By Auto CMD12 Error</p> <p>Setting this bit to 1 means CMD_wo_DAT is not executed due to an auto CMD12 error (D04-D01) in this register.</p> <p>0b No error 1b Not issued</p>
6-5 Reserved	This read-only field is reserved and always has the value zero.
4 AC12IE	<p>Auto CMD12 Index Error</p> <p>Occurs if the command index error occurs in response to a command.</p> <p>0b No error 1b Error, the CMD index in response is not CMD12</p>
3 AC12CE	<p>Auto CMD12 CRC Error</p> <p>Occurs when detecting a CRC error in the command response.</p> <p>0b No CRC error 1b CRC Error met in auto CMD12 Response</p>
2 AC12EBE	<p>Auto CMD12 End Bit Error</p> <p>Occurs when detecting that the end bit of command response is 0 which should be 1.</p> <p>0b No error 1b End bit error generated</p>
1 AC12TOE	<p>Auto CMD12 Timeout Error</p> <p>Occurs if no response is returned within 64 SDCLK cycles from the end bit of the command. If this bit is set to 1, the other error status bits (2-4) have no meaning.</p> <p>0b No error 1b Time out</p>
0 AC12NE	<p>Auto CMD12 Not Executed</p> <p>If memory multiple block data transfer is not started, due to a command error, this bit is not set because it is not necessary to issue an auto CMD12. Setting this bit to 1 means the SDHC cannot issue the auto CMD12 to stop a memory multiple block data transfer due to some error. If this bit is set to 1, other error status bits (1-4) have no meaning.</p> <p>0b Executed 1b Not executed</p>

48.4.17 Host Controller Capabilities (SDHC_HTCAPBLT)

This register provides the host driver with information specific to the SDHC implementation. The value in this register is the power-on-reset value, and does not change with a software reset. Any write to this register is ignored.

Address: SDHC_HTCAPBLT is 400B_1000h base + 40h offset = 400B_1040h

Bit	31	30	29	28	27	26	25	24	23	22	21	20	19	18	17	16
R	0					VS18	VS30	VS33	SRS	DMAS	HSS	ADMAS	0	MBL		
W	[Greyed out]															
Reset	0	0	0	0	0	1	1	1	1	1	1	1	0	0	1	1
Bit	15	14	13	12	11	10	9	8	7	6	5	4	3	2	1	0
R	0															
W	[Greyed out]															
Reset	0	0	0	0	0	0	0	0	0	0	0	0	0	0	0	0

SDHC_HTCAPBLT field descriptions

Field	Description
31–27 Reserved	This read-only field is reserved and always has the value zero.
26 VS18	Voltage Support 1.8 V This bit shall depend on the host system ability. 0b 1.8 V not supported 1b 1.8 V supported
25 VS30	Voltage Support 3.0 V This bit shall depend on the host system ability. 0b 3.0 V not supported 1b 3.0 V supported
24 VS33	Voltage Support 3.3 V This bit shall depend on the host system ability. 0b 3.3 V not supported 1b 3.3 V supported

Table continues on the next page...

SDHC_HTCAPBLT field descriptions (continued)

Field	Description
23 SRS	<p>Suspend/Resume Support</p> <p>This bit indicates whether the SDHC supports suspend / resume functionality. If this bit is 0, the suspend and resume mechanism, as well as the read Wwait, are not supported, and the host driver shall not issue either suspend or resume commands.</p> <p>0b Not supported 1b Supported</p>
22 DMAS	<p>DMA Support</p> <p>This bit indicates whether the SDHC is capable of using the internal DMA to transfer data between system memory and the data buffer directly.</p> <p>0b DMA not supported 1b DMA supported</p>
21 HSS	<p>High Speed Support</p> <p>This bit indicates whether the SDHC supports high speed mode and the host system can supply a SD Clock frequency from 25 MHz to 50 MHz.</p> <p>0b High speed not supported 1b High speed supported</p>
20 ADMAS	<p>ADMA Support</p> <p>This bit indicates whether the SDHC supports the ADMA feature.</p> <p>0b Advanced DMA not supported 1b Advanced DMA supported</p>
19 Reserved	<p>This read-only field is reserved and always has the value zero.</p>
18–16 MBL	<p>Max Block Length</p> <p>This value indicates the maximum block size that the host driver can read and write to the buffer in the SDHC. The buffer shall transfer block size without wait cycles.</p> <p>000b 512 bytes 001b 1024 bytes 010b 2048 bytes 011b 4096 bytes</p>
15–0 Reserved	<p>This read-only field is reserved and always has the value zero.</p>

48.4.18 Watermark Level Register (SDHC_WML)

Both write and read watermark levels (FIFO threshold) are configurable. Their value can range from 1 to 128 words. Both write and read burst lengths are also configurable. Their value can range from 1 to 31 words.

Address: SDHC_WML is 400B_1000h base + 44h offset = 400B_1044h

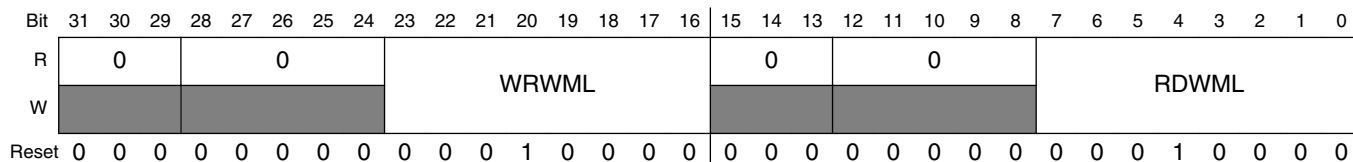

SDHC_WML field descriptions

Field	Description
31–29 Reserved	This read-only field is reserved and always has the value zero.
28–24 Reserved	This read-only field is reserved and always has the value zero.
23–16 WRWML	Write Watermark Level The number of words used as the watermark level (FIFO threshold) in a DMA write operation. Also the number of words as a sequence of write bursts in back-to-back mode. The maximum legal value for the write watermark level is 128.
15–13 Reserved	This read-only field is reserved and always has the value zero.
12–8 Reserved	This read-only field is reserved and always has the value zero.
7–0 RDWML	Read Watermark Level The number of words used as the watermark level (FIFO threshold) in a DMA read operation. Also the number of words as a sequence of read bursts in back-to-back mode. The maximum legal value for the read water mark level is 128.

48.4.19 Force Event Register (SDHC_FEVT)

The force event register is not a physically implemented register. Rather, it is an address at which the interrupt status register can be written if the corresponding bit of the interrupt status enable register is set. This register is a write only register and writing 0 to it has no effect. Writing 1 to this register actually sets the corresponding bit of interrupt status register. A read from this register always results in 0's. In order to change the corresponding status bits in the interrupt status register, make sure to set SYSCCTL[IPGEN] so that bus clock is always active.

memory map and register definition

Forcing a card interrupt will generate a short pulse on the DAT[1] line, and the driver may treat this interrupt as a normal interrupt. The interrupt service routine may skip polling the card interrupt factor as the interrupt is self cleared.

Address: SDHC_FEVT is 400B_1000h base + 50h offset = 400B_1050h

Bit	31	30	29	28	27	26	25	24	23	22	21	20	19	18	17	16
R	0			0				0		0	0	0	0	0	0	0
W	CINT	0		DMAE	0			AC12E	0	DEBE	DCE	DTOE	CIE	CEBE	CCE	CTOE
Reset	0	0	0	0	0	0	0	0	0	0	0	0	0	0	0	0
Bit	15	14	13	12	11	10	9	8	7	6	5	4	3	2	1	0
R									0			0	0	0	0	0
W				0					CNIBAC12E	0		AC12IE	AC12EBE	AC12CE	AC12TOE	AC12NE
Reset	0	0	0	0	0	0	0	0	0	0	0	0	0	0	0	0

SDHC_FEVT field descriptions

Field	Description
31 CINT	Force Event Card Interrupt Writing 1 to this bit generates a short low-level pulse on the internal DAT[1] line, as if a self clearing interrupt was received from the external card. If enabled, the CINT bit will be set and the interrupt service routine may treat this interrupt as a normal interrupt from the external card.
30-29 Reserved	This field is reserved.
28 DMAE	Force Event DMA Error Forces the DMAE bit of Interrupt Status Register to be set.
27-25 Reserved	This field is reserved.
24 AC12E	Force Event Auto Command 12 Error Forces the IRQSTAT[AC12E] to be set.
23 Reserved	This field is reserved.
22 DEBE	Force Event Data End Bit Error

Table continues on the next page...

SDHC_FEVT field descriptions (continued)

Field	Description
	Forces the IRQSTAT[DEBE] bit to be set.
21 DCE	Force Event Data CRC Error Forces the IRQSTAT[DCE] bit to be set.
20 DTOE	Force Event Data Time Out Error Force the IRQSTAT[DTOE] bit to be set.
19 CIE	Force Event Command Index Error Forces the IRQSTAT[CCE] bit to be set.
18 CEBE	Force Event Command End Bit Error Forces the IRQSTAT[CEBE] bit to be set.
17 CCE	Force Event Command CRC Error Forces the IRQSTAT[CCE] bit to be set.
16 CTOE	Force Event Command Time Out Error Forces the IRQSTAT[CTOE] bit to be set.
15–8 Reserved	This field is reserved.
7 CNIBAC12E	Force Event Command Not Executed By Auto Command 12 Error Forces the AC12ERR[CNIBAC12E] bit to be set.
6–5 Reserved	This field is reserved.
4 AC12IE	Force Event Auto Command 12 Index Error Forces the AC12ERR[AC12IE] bit to be set.
3 AC12EBE	Force Event Auto Command 12 End Bit Error Forces the AC12ERR[AC12EBE] bit to be set.
2 AC12CE	Force Event Auto Command 12 CRC Error Forces the AC12ERR[AC12CE] bit to be set.
1 AC12TOE	Force Event Auto Command 12 Time Out Error Forces the AC12ERR[AC12TOE] bit to be set.
0 AC12NE	Force Event Auto Command 12 Not Executed Forces the AC12ERR[AC12NE] bit to be set.

48.4.20 ADMA Error Status Register (SDHC_ADMAES)

When an ADMA error interrupt has occurred, the ADMA error states field in this register holds the ADMA state and the ADMA system address register holds the address around the error descriptor.

For recovering from this error, the host driver requires the ADMA state to identify the error descriptor address as follows:

- **ST_STOP:** Previous location set in the ADMA System Address register is the error descriptor address.
- **ST_FDS:** Current location set in the ADMA System Address register is the error descriptor address.
- **ST_CADR:** This state is never set because it only increments the descriptor pointer and doesn't generate an ADMA error.
- **ST_TFR:** Previous location set in the ADMA System Address register is the error descriptor address.

In case of a write operation, the host driver should use the ACMD22 to get the number of the written block, rather than using this information, since unwritten data may exist in the host controller.

The host controller generates the ADMA error interrupt when it detects invalid descriptor data (valid = 0) in the ST_FDS state. The host driver can distinguish this error by reading the valid bit of the error descriptor.

Table 48-30. ADMA Error State Coding

D01-D00	ADMA error state (when error has occurred)	Contents of ADMA system address register
00	ST_STOP (Stop DMA)	Holds the address of the next executable descriptor command
01	ST_FDS (fetch descriptor)	Holds the valid descriptor address
10	ST_CADR (change address)	No ADMA error is generated
11	ST_TFR (Transfer Data)	Holds the address of the next executable descriptor command

Address: SDHC_ADMAES is 400B_1000h base + 54h offset = 400B_1054h

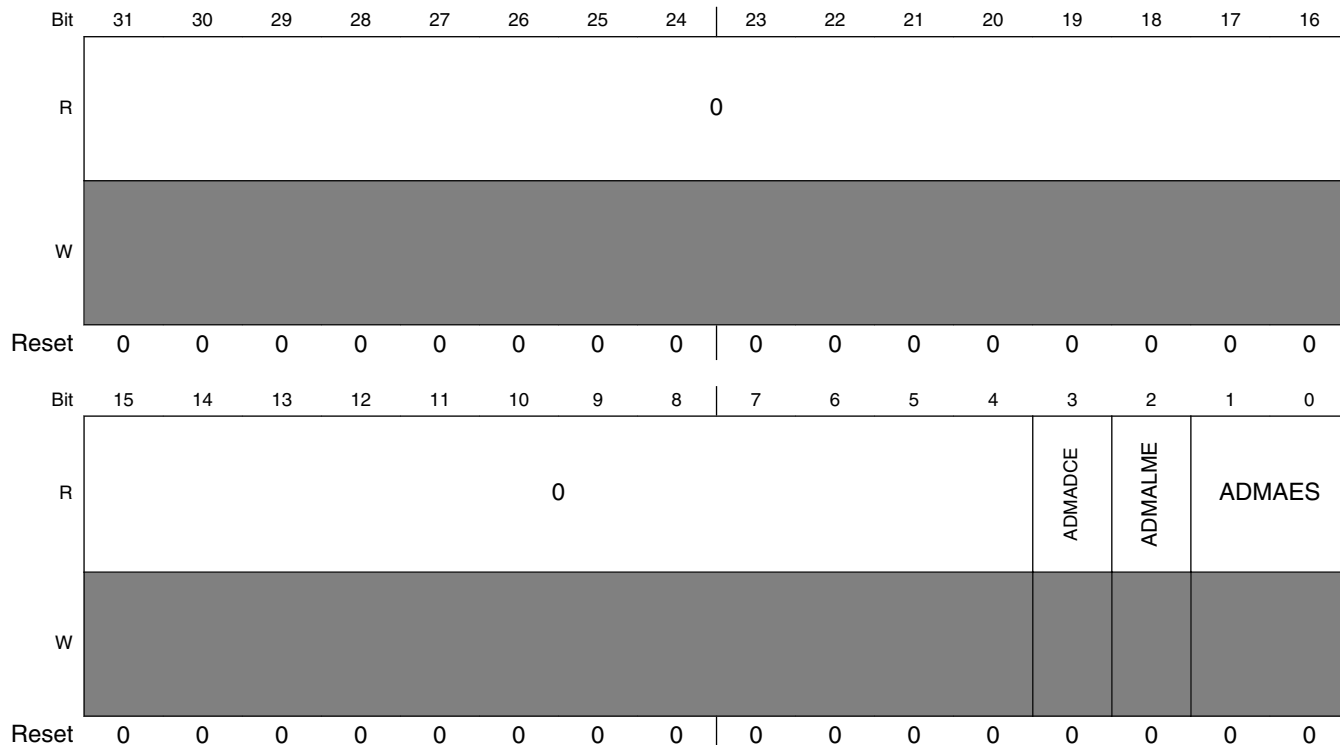

SDHC_ADMAES field descriptions

Field	Description
31–4 Reserved	This read-only field is reserved and always has the value zero.
3 ADMADCE	ADMA Descriptor Error This error occurs when invalid descriptor is fetched by ADMA. 0b No error 1b Error
2 ADMALME	ADMA Length Mismatch Error This error occurs in the following 2 cases: <ul style="list-style-type: none"> While the block count enable is being set, the total data length specified by the descriptor table is different from that specified by the block count and block length. Total data length can not be divided by the block length. 0b No error 1b Error
1–0 ADMAES	ADMA Error State (when ADMA Error is occurred.) This field indicates the state of the ADMA when an error has occurred during an ADMA data transfer.

48.4.21 ADMA System Address Register (SDHC_ADSADDR)

This register contains the physical system memory address used for ADMA transfers.

Address: SDHC_ADSADDR is 400B_1000h base + 58h offset = 400B_1058h

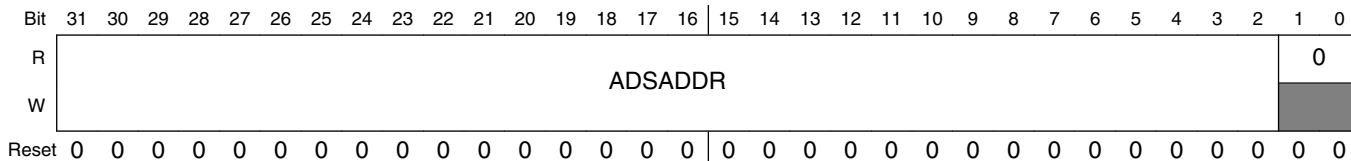

SDHC_ADSADDR field descriptions

Field	Description
31–2 ADSADDR	ADMA System Address This register holds the word address of the executing command in the descriptor table. At the start of ADMA, the host driver shall set the start address of the Descriptor table. The ADMA engine increments this register address whenever fetching a descriptor command. When the ADMA is stopped at the block gap, this register indicates the address of the next executable descriptor command. When the ADMA error interrupt is generated, this register shall hold the valid descriptor address depending on the ADMA state. The lower 2 bits of this register is tied to '0' so the ADMA address is always word aligned. Since this register supports dynamic address reflecting, when TC bit is set, it automatically alters the value of internal address counter, so SW cannot change this register when TC bit is set.
1–0 Reserved	This read-only field is reserved and always has the value zero.

48.4.22 Vendor Specific Register (SDHC_VENDOR)

This register contains the vendor specific control/status register.

Address: SDHC_VENDOR is 400B_1000h base + C0h offset = 400B_10C0h

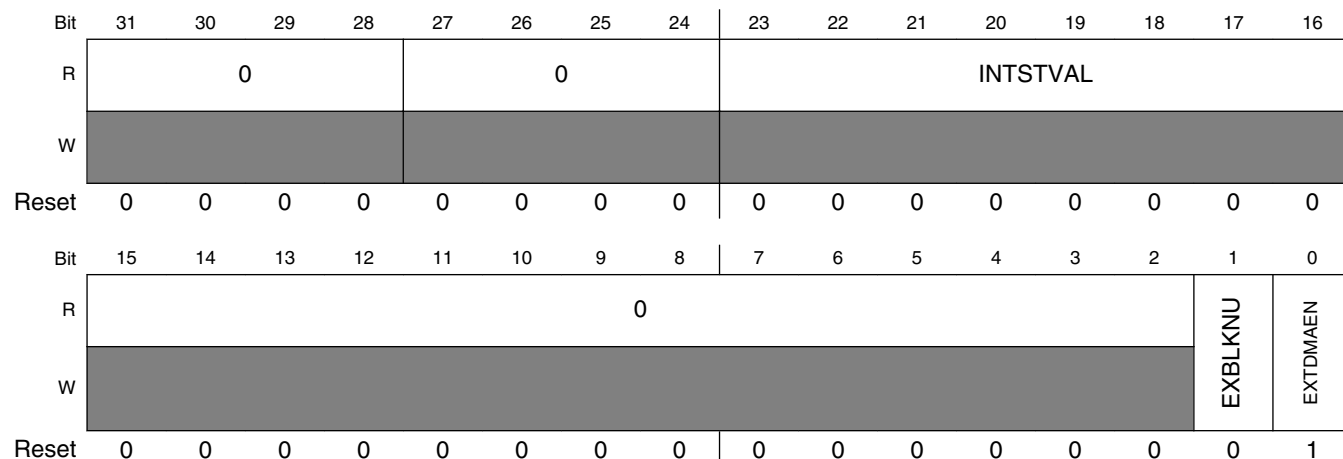

SDHC_VENDOR field descriptions

Field	Description
31–28 Reserved	This read-only field is reserved and always has the value zero.
27–24 Reserved	This read-only field is reserved and always has the value zero.
23–16 INTSTVAL	Internal State Value Internal state value, reflecting the corresponding state value selected by Debug Select field. This field is read-only and write to this field does not have effect.
15–2 Reserved	This read-only field is reserved and always has the value zero.
1 EXBLKNU	Exact block number block read enable for SDIO CMD53 This bit must be set before S/W issues CMD53 multi-block read with exact block number. This bit must not be set if the CMD53 multi-block read is not exact block number. 0 none exact block read. 1 Exact block read for SDIO CMD53.
0 EXTDMAEN	External DMA Request Enable Enable the request to external DMA. When the internal DMA (either simple DMA or advanced DMA) is not in use, and this bit is set, SDHC will send out DMA request when the internal buffer is ready. This bit is particularly useful when transferring data by CPU polling mode, and it is not allowed to send out the external DMA request. By default, this bit is set. 0 In any scenario, SDHC does not send out external DMA request. 1 When internal DMA is not active, the external DMA request will be sent out.

48.4.23 MMC Boot Register (SDHC_MMCBOOT)

This register contains the MMC fast boot control register.

Address: SDHC_MMCBOOT is 400B_1000h base + C4h offset = 400B_10C4h

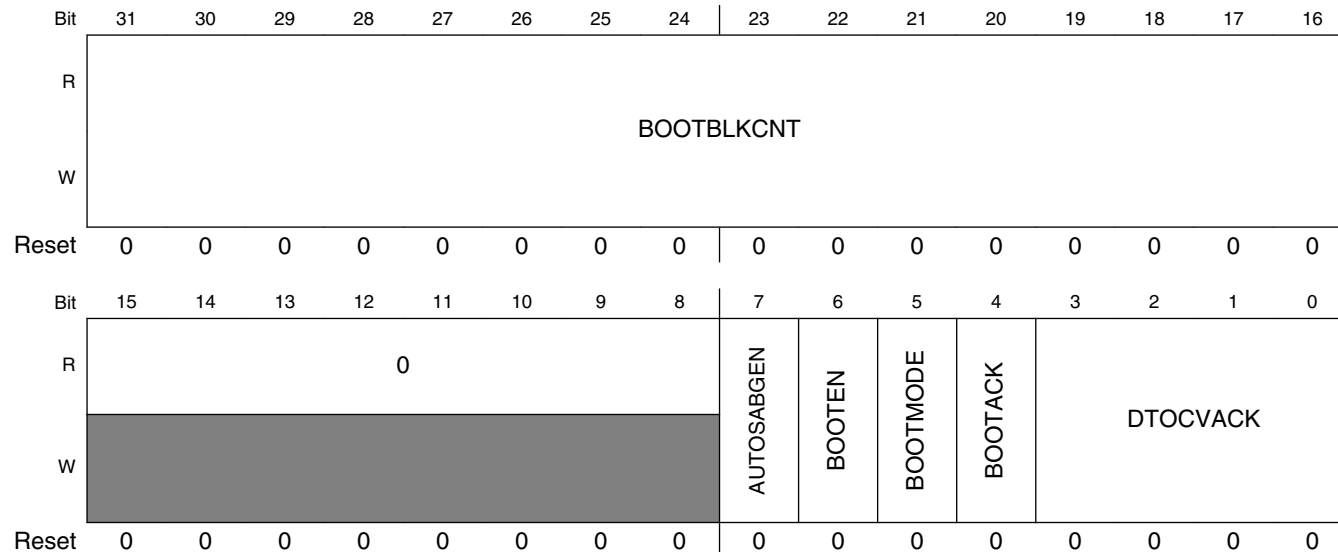

SDHC_MMCBOOT field descriptions

Field	Description
31–16 BOOTBLKCNT	The value defines the stop at block gap value of automatic mode. When received card block cnt is equal to BOOTBLKCNT and AUTOSABGEN is 1, then stop at block gap.
15–8 Reserved	This read-only field is reserved and always has the value zero.
7 AUTOSABGEN	When boot, enable auto stop at block gap function. This function will be triggered, and host will stop at block gap when received card block cnt is equal to BOOTBLKCNT.
6 BOOTEN	Boot mode enable 0 Fast boot disable 1 Fast boot enable
5 BOOTMODE	Boot mode select 0 Normal boot 1 Alternative boot
4 BOOTACK	Boot ack mode select 0 No ack 1 Ack
3–0 DTOCVACK	Boot ACK time out counter value. 0000b SDCLK x 2 ⁸ 0001b SDCLK x 2 ⁹ 0010b SDCLK x 2 ¹⁰

Table continues on the next page...

SDHC_MMBOOT field descriptions (continued)

Field	Description
0011b	SDCLK x 2 ¹¹
0100b	SDCLK x 2 ¹²
0101b	SDCLK x 2 ¹³
0110b	SDCLK x 2 ¹⁴
0111b	SDCLK x 2 ¹⁵
...	
1110b	SDCLK x 2 ²²
1111b	Reserved

48.4.24 Host Controller Version (SDHC_HOSTVER)

This register contains the vendor host controller version information. All bits are read only and will read the same as the power-reset value.

Address: SDHC_HOSTVER is 400B_1000h base + FCh offset = 400B_10FCh

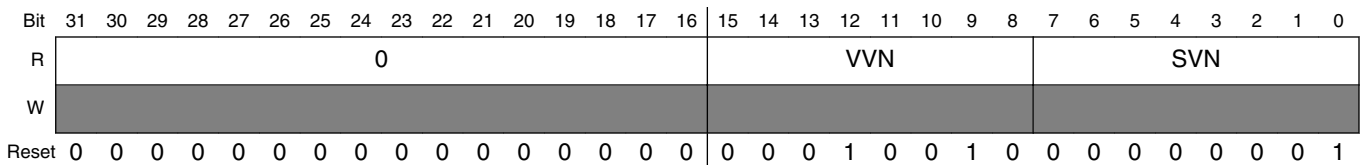

SDHC_HOSTVER field descriptions

Field	Description
31–16 Reserved	This read-only field is reserved and always has the value zero.
15–8 VVN	Vendor Version Number These status bits are reserved for the vendor version number. The host driver shall not use this status. 00h Freescale SDHC version 1.0 10h Freescale SDHC version 2.0 11h Freescale SDHC version 2.1 12h Freescale SDHC version 2.2 All others Reserved
7–0 SVN	Specification Version Number These status bits indicate the host controller specification version. 01h SD host specification version 2.0, supports test event register and ADMA. All others Reserved

48.5 Functional description

The following sections provide a brief functional description of the major system blocks, including the data buffer, DMA crossbar switch interface, dual-port memory wrapper, data/command controller, clock & reset manager and clock generator.

48.5.1 Data buffer

The SDHC uses one configurable data buffer, so that data can be transferred between the system bus and the SD card, with an optimized manner to maximize throughput between the two clock domains (that is, the IP peripheral clock, and the master clock). The following diagram illustrates the buffer scheme. The buffer is used as temporary storage for data being transferred between the host system and the card. The watermark levels for read and write are both configurable, and can be any number from 1 to 128 words. The burst lengths for read and write are also configurable, and can be any number from 1 to 31 words.

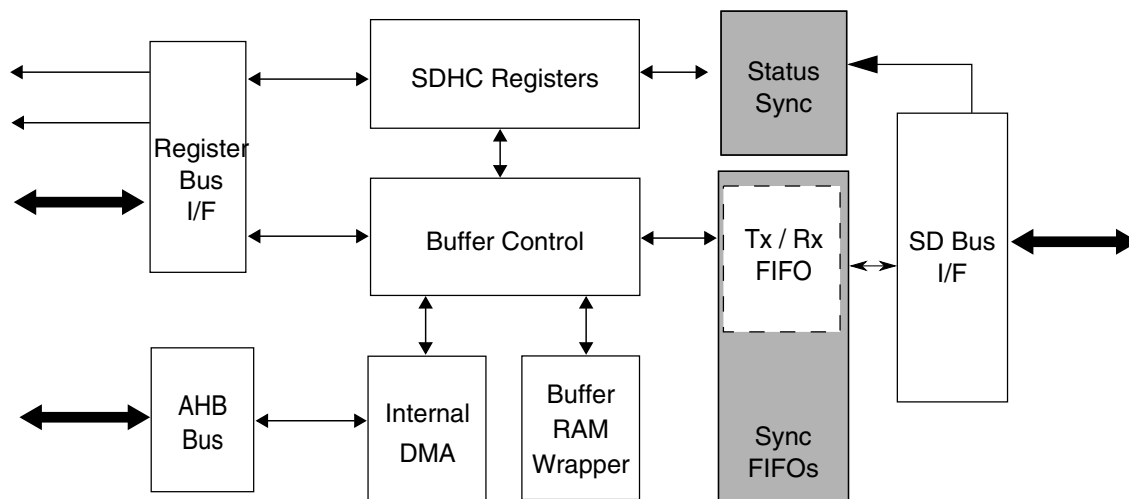

Figure 48-27. SDHC buffer scheme

There are 3 transfer modes to access the data buffer:

- CPU polling mode:
 - For a host read operation, when the number of words received in the buffer meets or exceeds the RDWML watermark value, then by polling the IRQSTAT[BRR] bit the host driver can read the DATPORT register to fetch the amount of words set in the WML register from the buffer. The write operation is similar.

- External DMA mode:
 - For a read operation, when there are more words received in the buffer than the amount set in the RDWML register, a DMA request is sent out to inform the external DMA to fetch the data. The request will be immediately de-asserted when there is an access on the DATPORT register. If the number of words in the buffer after the current burst meets or exceeds RDWML value, then the DMA request is asserted again. So for instance if there are twice as many words in the buffer than the RDWML value, there are two successive DMA requests with only one cycle of de-assertion between. The write operation is similar.

Note the accesses CPU polling mode and external DMA mode both use the IP bus, and if the external DMA is enable, in both modes an external DMA request is sent out whenever the buffer is ready.
- Internal DMA mode (includes simple and advanced DMA access's):
 - The internal DMA access, either by simple or advanced DMA, is over the crossbar switch bus. For internal DMA access mode, the external DMA request will never be sent out.

For a read operation, when there are more words in the buffer than the amount set in the WML register, the internal DMA starts fetching data over the crossbar switch bus. Except INCR4 and INCR8, the burst type is always INCR mode and the burst length depends on the shortest of following factors:

1. Burst length configured in the burst length field of the WML register
2. Watermark level boundary
3. Block size boundary
4. Data boundary configured in the current descriptor (if the ADMA is active)
5. 1 KB address boundary

Write operation is similar.

Sequential and contiguous access is necessary to ensure the pointer address value is correct. Random or skipped access is not possible. The byte order, by reset, is little endian mode. The actually byte order is swapped inside the buffer, according to the endian mode configured by software, as illustrated in the following diagrams. For a host write operation, byte order is swapped after data is fetched from the buffer and ready to send to the SD bus. For a host read operation, byte order is swapped before the data is stored into the buffer.

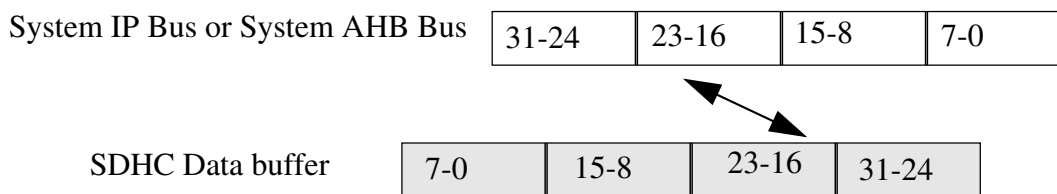

Figure 48-28. Data swap between system bus and SDHC data buffer in byte little endian mode

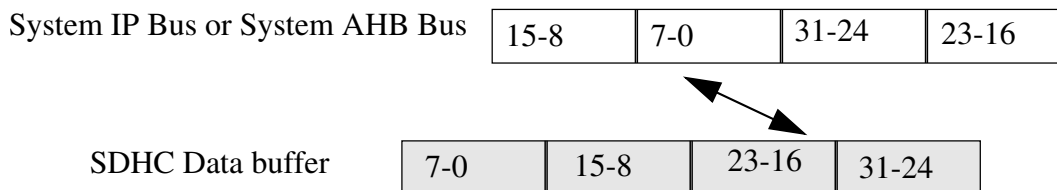

Figure 48-29. Data swap between system bus and SDHC data buffer in half word big endian mode

48.5.1.1 Write operation sequence

There are three ways to write data into the buffer when the user transfers data to the card:

1. By using external DMA through the SDHC DMA request signal.
2. By processor core polling through the IRQSTAT[BWR] bit (interrupt or polling).
3. By using the internal DMA.

When the internal DMA is not used, (i.e. the XFERTYP[DMAEN] bit is not set when the command is sent), the SDHC asserts a DMA request when the amount of buffer space exceeds the value set in the WML register, and is ready for receiving new data. At the same time, the SDHC would set the IRQSTAT[BWR] bit. The buffer write ready interrupt will be generated if it is enabled by software.

When internal DMA is used, the SDHC will not inform the system before all the required number of bytes are transferred (if no error was encountered). When an error occurs during the data transfer, the SDHC will abort the data transfer and abandon the current block. The host driver should read the contents of the DSADDR to get the starting address of the abandoned data block. If the current data transfer is in multi block mode, the SDHC will not automatically send CMD12, even though the XFERTYP[AC12EN] bit is set. The host driver shall send CMD12 in this scenario and re-start the write operation from that address. It is recommended that a software reset for data be applied before the transfer is re-started after error recovery.

The SDHC will not start data transmission until the number of words set in the WML register can be held in the buffer. If the buffer is empty and the host system does not write data in time, the SDHC will stop the SD_CLK to avoid the data buffer under-run situation.

48.5.1.2 Read operation sequence

There are three ways to read data from the buffer when the user transfers data to the card:

1. By using the external DMA through the SDHC DMA request signal
2. By processor core polling through the IRQSTAT[BRR] bit (interrupt or polling)
3. By using the internal DMA

When internal DMA is not used (i.e. XFERTYP[DMAEN] bit is not set when the command is sent), the SDHC asserts a DMA request when the amount of data exceeds the value set in the WML register, that is available and ready for system fetching data. At the same time, the SDHC would set the IRQSTAT[BRR] bit. The buffer read ready interrupt will be generated if it is enabled by software.

When internal DMA is used, the SDHC will not inform the system before all the required number of bytes are transferred (if no error was encountered). When an error occurs during the data transfer, the SDHC will abort the data transfer and abandon the current block. The host driver should read the content of the DMA system address register to get the starting address of the abandoned data block. If the current data transfer is in multi block mode, the SDHC will not automatically send CMD12, even though the XFERTYP[AC12EN] bit is set. The host driver shall send CMD12 in this scenario and re-start the read operation from that address. It is recommended that a software reset for data be applied before the transfer is re-started after error recovery.

For any write transfer mode, the SDHC will not start data transmission until the number of words set in the WML register are in the buffer. If the buffer is full and the Host System does not read data in time, the SDHC will stop the SDHC_DCLK to avoid the data buffer over-run situation.

48.5.1.3 Data buffer and block size

The user needs to know the buffer size, for the buffer operation during a data transfer, to utilize it in the most optimized way. In the SDHC, the only data buffer can hold up to 128 words (32-bit), and the watermark levels for write and read can be configured respectively. For both read and write, the watermark level can be from 1 word to the

maximum of 128 words. For both read and write, the burst length, can be from 1 word to the maximum of 31 words. The host driver may configure the value according to the system situation and requirement.

During a multi-block data transfer, the block length may be set to any value between 1 and 4096 bytes inclusive which satisfies the requirements of the external card. The only restriction is from the external card. It might not support that large of a block or it doesn't support a partial block access (which is not the integer times of 512 bytes).

For block size not times of 4, i.e., not word aligned, SDHC requires stuff bytes at the end of each block, because SDHC treats each block individually. For example, the block size is 7 bytes, there are 12 blocks to write, the system side must write 2 times for each block, and for each block, the ending byte would be abandoned by SDHC since it only sends 7 bytes to the card and picks data from the following system write, so there would be 24 beats of write access in total.

48.5.1.4 Dividing large data transfer

This SDIO command CMD53 definition, limits the maximum data size of data transfers according to the following formula:

Max data size = Block size x Block count

The length of a multiple block transfer needs to be in block size units. If the total data length can't be divided evenly into a multiple of the block size, then there are two ways to transfer the data which depend on the function and the card design. Option 1 is for the host driver to split the transaction. The remainder of the block size data is then transferred by using a single block command at the end. Option 2 is to add dummy data in the last block to fill the block size. For option 2, the card must manage the removal of the dummy data.

The following diagram illustrates the dividing of large data transfers. Assuming a kind of WLAN SDIO card only supports block size up to 64 bytes. Although the SDHC supports a block size of up to 4096 bytes, the SDIO can only accept a block size less than 64 bytes, so the data must be divided (see example below).

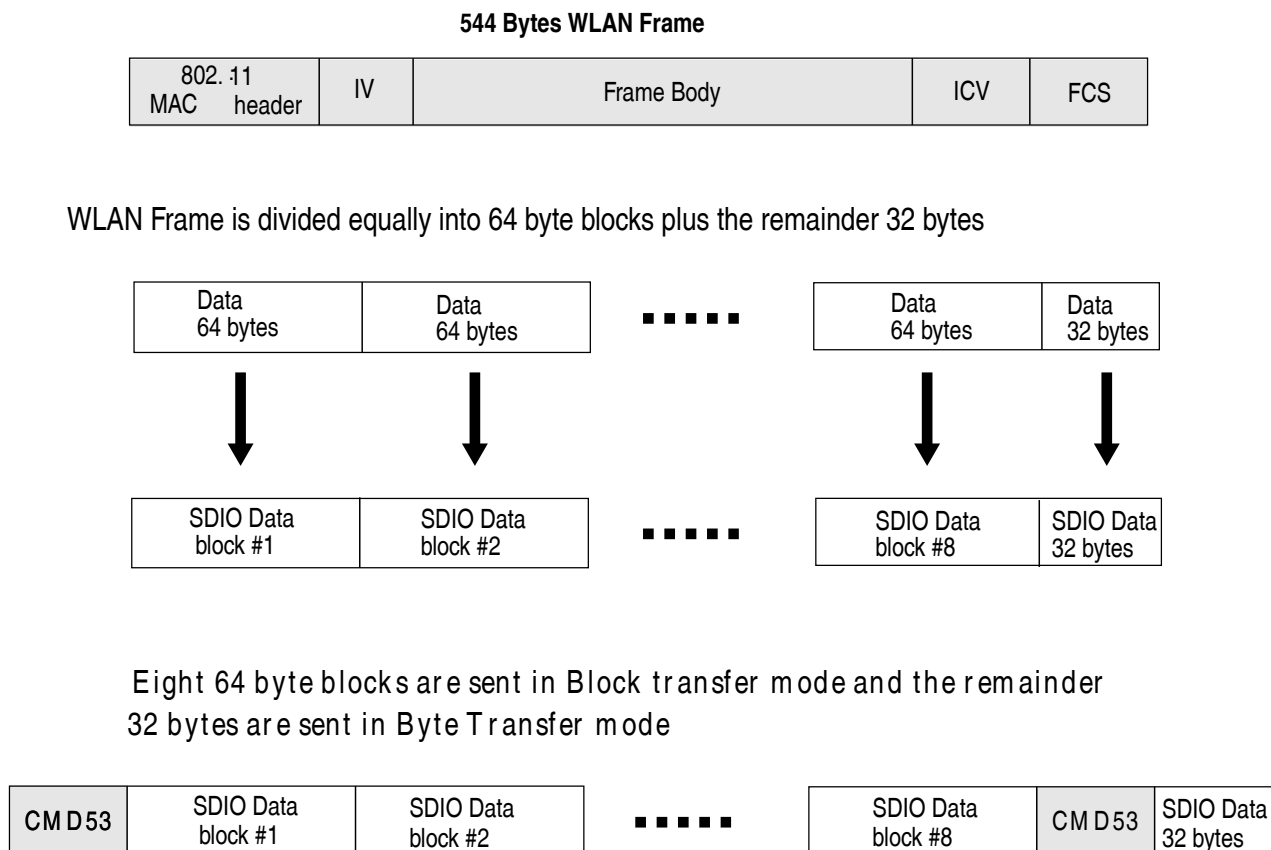

Figure 48-30. Example for dividing large data transfers

48.5.1.5 External DMA request

When the internal DMA is not in use, and external DMA request is enabled, the data buffer will generate a DMA request to the system. During a write operation, when the number of WRWML words can be held in the buffer free space, a DMA request is sent, informing the host system of a DMA write. The IRQSTAT[BWR] bit is also set, as long as the IRQSTATEN[BWRSEN] bit is set. The DMA request is immediately de-asserted when an access to the DATPORT register is made. If the buffer's free space still meets the watermark condition, the DMA request is asserted again after a cycle.

On read operation, when the number of RDWML words are already in the buffer, a DMA request is sent, informing the host system for a DMA read. The IRQSTAT[BRR] bit is also set, as long as the IRQSTATEN[BRRSEN] bit is set. The DMA request is immediately de-asserted when an access to the DATPORT register is made. If the buffer's data still meets the watermark condition, the DMA request is asserted again after a cycle.

Because the DMA burst length can't change during a data transfer for an external DMA transfer, the watermark level (read or write) must be a divisor of the block size. If it is not, transferring of the block may cause buffer under-run (read operation) or over-run (write operation). For example, if the block size is 512 bytes, the watermark level of read (or write) must be a power of two between 1 and 128. For processor core polling access, as the last access in the block transfer can be controlled by software, there is no such issue. The watermark level can be any value, even larger than the block size (but no greater than 128 words). This is because the actual number of bytes transferred by the software can be controlled and does not exceed the block size in each transfer.

The SDHC also supports non-word aligned block size, as long as the card supports that block size. In this case, the watermark level should be set as the number of words. For example, if the block size is 31 bytes, the watermark level can be set to any number of word. For this case, the BLKATTR[BLKSIZE] bits shall be set as 1fh. For the CPU polling access, the burst length can be 1 to 128 words, without restriction. This is because the software will transfer 8 words, and the SDHC will also set the IRQSTAT[BWR] or IRQSTAT[BRR] bits when the remaining data does not violate data buffer. Refer to [DMA burst length](#) for more details about the dynamic watermark level of the data buffer. For the above example, even though 8 words are transferred via the DATPORT register, the SDHC will transfer only 31 bytes over the SD bus, as required by the BLKATTR[BLKSIZE] bits. In this data transfer, with non-word aligned block size, the endian mode should be set cautiously, or invalid data will be transferred to/from the card.

48.5.2 DMA crossbar switch interface

The internal DMA implements a DMA engine and the crossbar switch master. When the internal DMA is enabled (XFERTYP[DMAEN] is set), the interrupt status bits are set if they are enabled. To avoid setting them, clear IRQSTATEN[BWRSEN, BRRSEN]. The following diagram illustrates the DMA crossbar switch interface block.

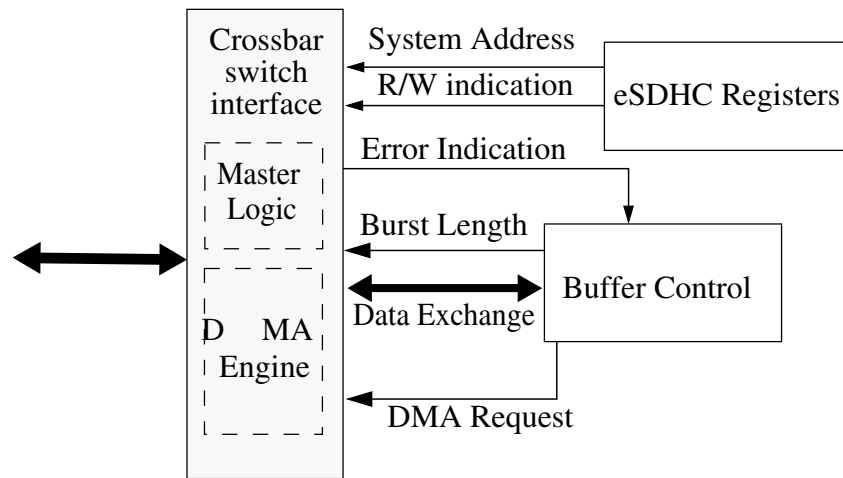

Figure 48-31. DMA crossbar switch interface block

48.5.2.1 Internal DMA request

If the watermark level requirement is met in data transfer, and the internal DMA is enabled, the data buffer block sends a DMA request to the crossbar switch interface. Meanwhile, the external DMA request signal is disabled. The delay in response from the internal DMA engine depends on the system bus loading and the priority assigned to the SDHC. The DMA engine does not respond to the request during its burst transfer, but is ready to serve as soon as the burst is over. The data buffer de-asserts the request once an access to the buffer is made. Upon access to the buffer by internal DMA, the data buffer updates its internal buffer pointer, and when the watermark level is satisfied, another DMA request is sent.

The data transfer is in the block unit, and the subsequent watermark level is always set as the remaining number of words. For instance, for a multi block data read with each block size of 31 bytes, and the burst length set to 6 words. After the first burst transfer, if there are more than 2 words in the buffer (which might contain some data of the next block), another DMA request read is sent. This is because the remaining number of words to send for the current block is $(31 - 6 * 4) / 4 = 2$. The SDHC will read 2 words out of the buffer, with 7 valid bytes and 1 stuff byte.

48.5.2.2 DMA burst length

Just like a CPU polling access, the DMA burst length for the internal DMA engine can be from 1 to 16 words. The actual burst length for the DMA depends on the lesser of the configured burst length or the remaining words of the current block. Take the example in [Internal DMA request](#) again. The following burst length after 6 words are read will be 2 words, and the next burst length will be 6 words again. This is because the next block

starts, which is 31 bytes, more than 6 words. The host driver writer may take this variable burst length into account. It is also acceptable to configure the burst length as the divisor of the block size, so that each time the burst length will be the same.

48.5.2.3 Crossbar switch master interface

It is possible that the internal DMA engine could fail during the data transfer. When this error occurs, the DMA engine stops the transfer and goes to the idle state as well as the internal data buffer stops accepting incoming data. The IRQSTAT[DMAE] is set to inform the driver.

Once the DMAE interrupt is received, the software shall send a CMD12 to abort the current transfer and read the DSADDR[DSADDR] to get the starting address of the corrupted block. After the DMA error is fixed, the software should apply a data reset and re-start the transfer from this address to recover the corrupted block.

48.5.2.4 ADMA engine

In the SD host controller standard, the new DMA transfer algorithm called the ADMA (advanced DMA) is defined. For simple DMA, once the page boundary is reached, a DMA interrupt will be generated and the new system address shall be programmed by the host driver. The ADMA defines the programmable descriptor table in the system memory. The host driver can calculate the system address at the page boundary and program the descriptor table before executing ADMA. It reduces the frequency of interrupts to the host system. Therefore, higher speed DMA transfers could be realized since the host MCU intervention would not be needed during long DMA based data transfers.

There are two types of ADMA: ADMA1 and ADMA2 in host controller. ADMA1 can support data transfer of 4 KB aligned data in system memory. ADMA2 improves the restriction so that data of any location and any size can be transferred in system memory. Their formats of descriptor table are different.

ADMA can recognize all kinds of descriptors define in SD host controller standard, and if 'end' flag is detected in the descriptor, ADMA will stop after this descriptor is processed.

48.5.2.4.1 ADMA concept and descriptor format

For ADMA1, including the following descriptors:

- Valid/Invalid descriptor.
- Nop descriptor.
- Set data length descriptor.
- Set data address descriptor.
- Link descriptor.
- Interrupt flag and end flag in descriptor.

For ADMA2, including the following descriptors:

- Valid/Invalid descriptor.
- Nop descriptor.
- Rsv descriptor.
- Set data length & address descriptor.
- Link descriptor.
- Interrupt flag and end flag in descriptor.

ADMA2 deals with the lower 32-bit first, and then the higher 32-bit. If the 'Valid' flag of descriptor is 0, it will ignore the high 32-bit. Address field shall be set on word aligned(lower 2-bit is always set to 0). Data length is in byte unit.

ADMA will start read/write operation after it reaches the tran state, using the data length and data address analyzed from most recent descriptor(s).

For ADMA1, the valid data length descriptor is the last set type descriptor before tran type descriptor. Every tran type will trigger a transfer, and the transfer data length is extracted from the most recent set type descriptor. If there is no set type descriptor after the previous trans descriptor, the data length will be the value for previous transfer, or 0 if no set descriptor is ever met.

For ADMA2, tran type descriptor contains both data length and transfer data address, so only a tran type descriptor can start a data transfer

Table 48-35. Format of the ADMA1 descriptor table

Address/page field		Address/page field		Attribute field					
31	12	11	6	5	4	3	2	1	0
Address or data length		000000		Act2	Act1	0	Int	End	Valid

Table continues on the next page...

Table 48-35. Format of the ADMA1 descriptor table (continued)

Act2	Act1	Symbol	Comment	31-28	27-12
0	0	nop	No operation	Don't care	
0	1	set	Set data length	0000	Data length
1	0	tran	Transfer data	Data address	
1	1	link	Link descriptor	Descriptor address	
Valid		Valid = 1 indicates this line of descriptor is effective. If Valid = 0 generate ADMA error Interrupt and stop ADMA.			
End		End = 1 indicates current descriptor is the ending one.			
Int		Int = 1 generates DMA interrupt when this descriptor is processed.			

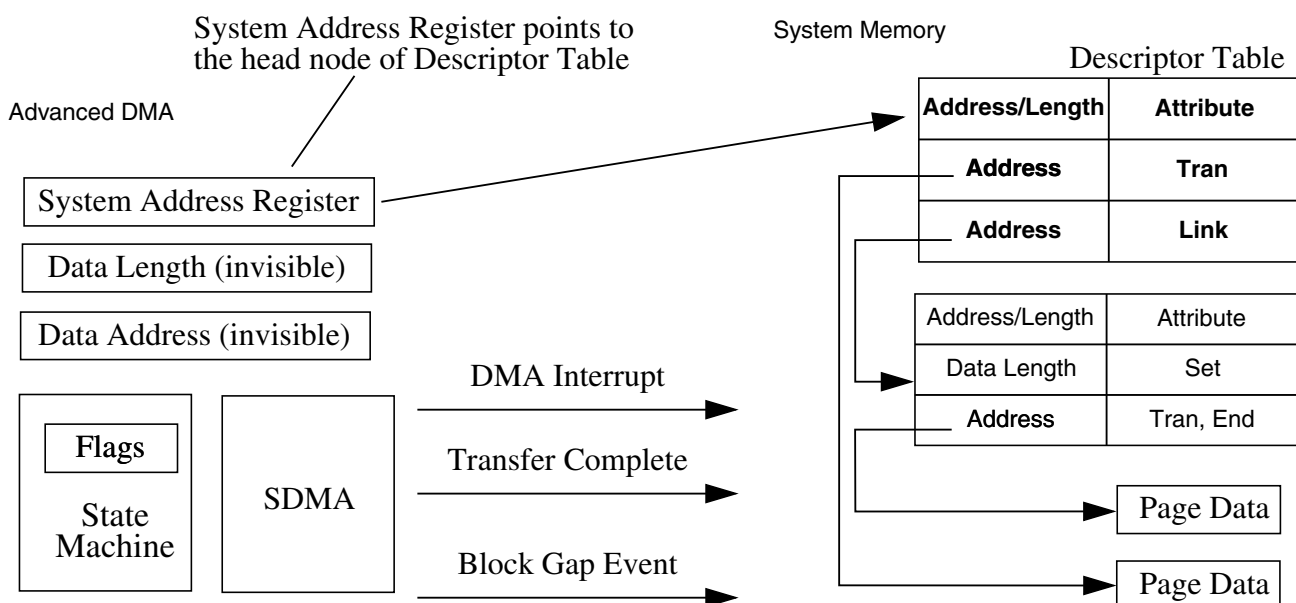

Figure 48-32. Concept and access method of ADMA1 descriptor table

Table 48-36. Format of the ADMA2 descriptor table

Address field		Length		Reserved		Attribute field					
63	32	31	16	15	06	05	04	03	02	01	00
32-bit address		16-bit length		0000000000		Act2	Act1	0	Int	End	Valid
Act2	Act1	Symbol	Comment	Operation							
0	0	nop	No operation	Don't care							
0	1	rsv	Reserved	Same as nop. Read this line and go to next one							
1	0	tran	Transfer data	Transfer data with address and length set in this descriptor line							
1	1	link	Link descriptor	Link to another descriptor							

Table continues on the next page...

Table 48-36. Format of the ADMA2 descriptor table (continued)

Valid	Valid = 1 indicates this line of descriptor is effective. If valid = 0 generate ADMA error interrupt and stop ADMA.
End	End = 1 indicates current descriptor is the ending one.
Int	Int = 1 generates DMA interrupt when this descriptor is done.

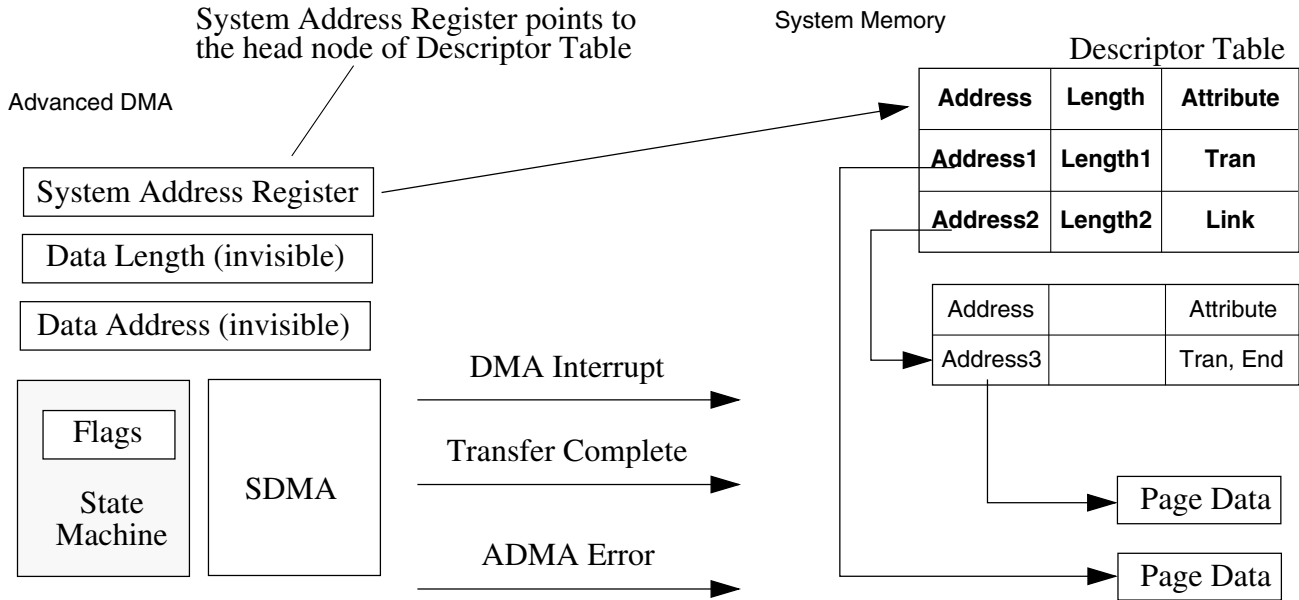

Figure 48-33. Concept and access method of ADMA2 descriptor table

48.5.2.4.2 ADMA interrupt

If the 'interrupt' flag of descriptor is set, ADMA will generate an interrupt according to different type descriptor:

For ADMA1:

- Set type descriptor: interrupt is generated when data length is set.
- Tran type descriptor: interrupt is generated when this transfer is complete.
- Link type descriptor: interrupt is generated when new descriptor address is set.
- Nop type descriptor: interrupt is generated just after this descriptor is fetched.

For ADMA2:

- Tran type descriptor: interrupt is generated when this transfer is complete.
- Link type descriptor: interrupt is generated when new descriptor address is set.
- Nop/Rsv type descriptor: interrupt is generated just after fetch this descriptor.

48.5.2.4.3 ADMA error

The ADMA stops whenever any error is encountered. These errors include:

- Fetching descriptor error
- Transfer error
- Data length mismatch error

ADMA descriptor error will be generated when it fails to detect 'valid' flag in the descriptor. If ADMA descriptor error occurs, the interrupt is not generated even if the 'interrupt' flag of this descriptor is set.

When XFERTYP[BCEN] bit is set, data length set in buffer must equal to the whole data length set in descriptor nodes, otherwise data length mismatch error will be generated.

If XFERTYP[BCEN] bit is not set, the whole data length set in descriptor should be times of block length, otherwise, when all data set in the descriptor nodes are done not at block boundary, the data mismatch error will occur.

48.5.3 SD protocol unit

The SD protocol unit deals with all SD protocol affairs.

The SD Protocol Unit performs the following functions:

- Acts as the bridge between the internal buffer and the SD bus
- Sends the command data as well as its argument serially
- Stores the serial response bit stream into corresponding registers
- Detects the bus state on the DAT[0] line
- Monitors the interrupt from the SDIO card
- Asserts the read wait signal
- Gates off the SD clock when buffer is announcing danger status
- Detects the write protect state

The SD protocol unit consists of four sub modules:

1. SD transceiver.

2. SD clock and monitor.
3. Command agent.
4. Data agent.

48.5.3.1 SD transceiver

In the SD protocol unit, the transceiver is the main control module. It consists of a FSM and control module, from which the control signals for all other three modules are generated.

48.5.3.2 SD clock & monitor

This module monitors the signal level on all 8 data lines, the command lines, and directly routes the level values into the register bank. The driver can use this for debug purposes.

The module also detects the CD (card detection) line as well as the DAT[3] line. The transceiver reports the card insertion state according to the CD state, or the signal level on the DAT[3] line, when the PROCTL[D3CD] bit is set.

The module detects the WP (write protect) line. With the information of the WP state, the register bank will ignore the command, accompanied by a write operation, when the WP switch is on.

If the internal data buffer is in danger, and the SD clock must be gated off to avoid buffer over/under-run, this module will assert the gate of the output SD clock to shut the clock off. After the buffer danger has recovered, and when the system access of the buffer catches up, the clock gate of this module will open and the SD clock will be active again.

This module also drive SDHC_LCTL output signal when the PROCTL[LCTL] bit is set by the driver.

48.5.3.3 Command agent

The command agent deals with the transactions on the CMD line. The following diagram illustrates the structure for the command CRC Shift Register.

functional description

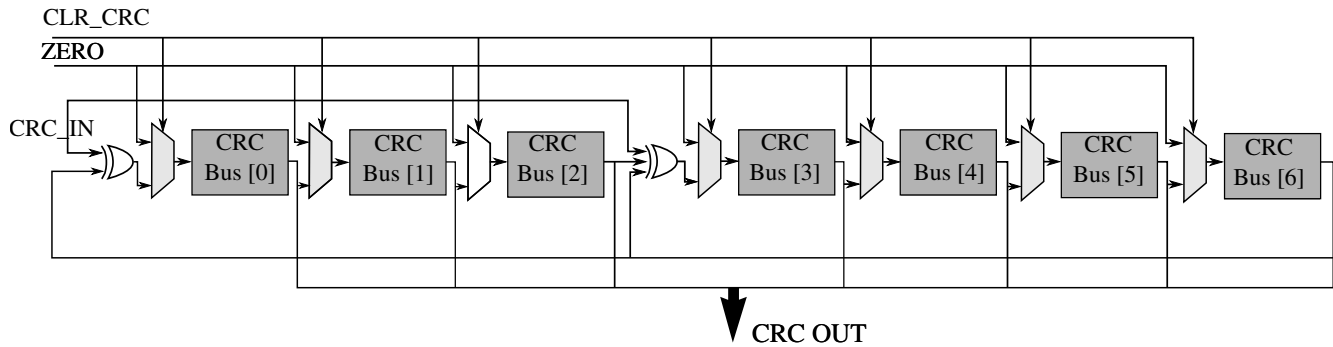

Figure 48-34. Command CRC Shift Register

The CRC polynomials for the CMD are as follows:

Generator polynomial: $G(x) = x^7 + x^3 + 1$
 $M(x) = (\text{first bit}) * x^n + (\text{second bit}) * x^{n-1} + \dots + (\text{last bit}) * x^0$
 $\text{CRC}[6:0] = \text{Remainder} [(M(x) * x^7) / G(x)]$

48.5.3.4 Data agent

The data agent deals with the transactions on the eight data lines. Moreover, this module also detects the busy state on the DAT[0] line, and generate the read wait state by the request from the transceiver. The CRC polynomials for the DAT are as follows:

Generator polynomial: $G(x) = x^{16} + x^{12} + x^5 + 1$
 $M(x) = (\text{first bit}) * x^n + (\text{second bit}) * x^{n-1} + \dots + (\text{last bit}) * x^0$
 $\text{CRC}[15:0] = \text{Remainder} [(M(x) * x^{16}) / G(x)]$

48.5.4 Clock & reset manager

This module controls all the reset signals within the SDHC.

There are four kinds of reset signals within SDHC:

1. Hardware reset.
2. Software reset for all.
3. Software reset for the data part.
4. Software reset for the command part.

All these signals are fed into this module and stable signals are generated inside the module to reset all other modules. The module also gates off all the inside signals.

There are three clocks inside the SDHC:

1. Bus clock.
2. SDHC clock.
3. System clock.

The module monitors the activities of all other modules, supplies the clocks for them, and when enabled, automatically gates off the corresponding clocks.

48.5.5 Clock generator

The clock generator generates the SDHC_CLK by peripheral source clock in two stages. The following diagram illustrates the structure of the divider. The term "base" represents the frequency of peripheral source clock.

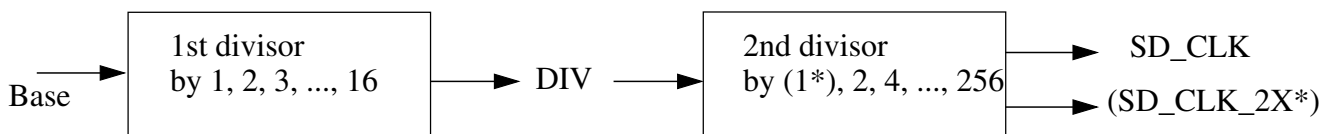

Figure 48-35. Two stages of the clock divider

The first stage outputs an intermediate clock (DIV), which can be base, base/2, base/3, ..., or base/16.

The second stage is a prescaler, and outputs the actual clock (SDHC_CLK). This clock is the driving clock for all sub modules of the SD protocol unit, and the sync FIFOs to synchronize with the data rate from the internal data buffer. The frequency of the clock output from this stage, can be DIV, DIV/2, DIV/4,..., or DIV/256. Thus the highest frequency of the SDHC_CLK is base, and the next highest is base/2, while the lowest frequency is base/4096. If the base clock is of equal duty ratio (usually true), the duty cycle of SDHC_CLK is also 50%, even when the compound divisor is an odd value.

48.5.6 SDIO card interrupt

This section discusses SDIO interrupt handling.

48.5.6.1 Interrupts in 1-bit mode

In this case the DAT[1] pin is dedicated to providing the interrupt function. An interrupt is asserted by pulling the DAT[1] low from the SDIO card, until the interrupt service is finished to clear the interrupt.

48.5.6.2 Interrupt in 4-bit mode

Since the interrupt and data line 1 share Pin 8 in 4-bit mode, an interrupt will only be sent by the card and recognized by the host during a specific time. This is known as the interrupt period. The SDHC will only sample the level on pin 8 during the interrupt period. At all other times, the host will ignore the level on pin 8, and treat it as the data signal. The definition of the interrupt period is different for operations with single block and multiple block data transfers.

In the case of normal single data block transmissions, the interrupt period becomes active two clock cycles after the completion of a data packet. This interrupt period lasts until after the card receives the end bit of the next command that has a data block transfer associated with it.

For multiple block data transfers in 4-bit mode, there is only a limited period of time that the interrupt period can be active due to the limited period of data line availability between the multiple blocks of data. This requires a more strict definition of the interrupt period. For this case, the interrupt period is limited to two clock cycles. This begins two clocks after the end bit of the previous data block. During this 2-clock cycle interrupt period, if an interrupt is pending, the SDHC_D1 line will be held low for one clock cycle with the last clock cycle pulling SDHC_D1 high. On completion of the Interrupt Period, the card releases the SDHC_D1 line into the high Z state. The SDHC samples the SDHC_D1] during the interrupt period when the PROCTL[IABG] bit is set.

Refer to SDIO Card Specification v1.10f for further information about the SDIO card interrupt.

48.5.6.3 Card interrupt handling

When the IRQSIGEN[CINTIEN] bit is set to 0, the SDHC clears the interrupt request to the host system. The host driver should clear this bit before servicing the SDIO Interrupt and should set this bit again after all interrupt requests from the card are cleared to prevent inadvertent interrupts.

The SDIO status bit is cleared by resetting the SDIO interrupt. Writing to this bit would have no effects. In 1-bit mode, the SDHC will detect the SDIO interrupt with or without the SD clock (to support wakeup). In 4-bit mode, the interrupt signal is sampled during the interrupt period, so there are some sample delays between the interrupt signal from the SDIO card and the interrupt to the host system interrupt controller. When the SDIO status has been set, and the host driver needs to service this interrupt, so the SDIO bit in the interrupt control register of SDIO card will be cleared. This is required to clear the

SDIO interrupt status latched in the SDHC and to stop driving the interrupt signal to the system interrupt controller. The host driver must issue a CMD52 to clear the card interrupt. After completion of the card interrupt service, the SDIO Interrupt Enable bit is set to 1, and the SDHC starts sampling the interrupt signal again.

The following diagram illustrates the SDIO card interrupt scheme and for the sequences of software and hardware events that take place during a card interrupt handling procedure.

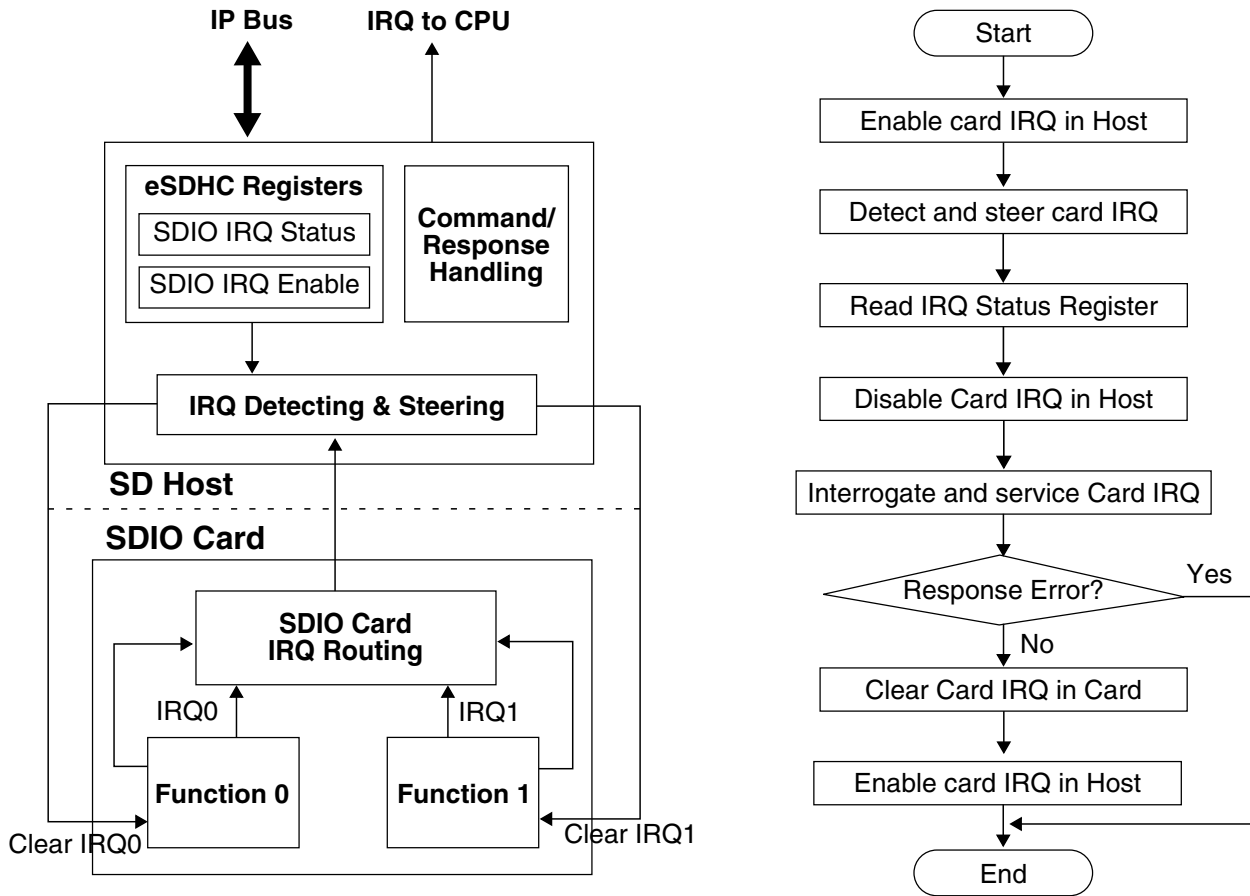

Figure 48-36. Card interrupt scheme and card interrupt detection and handling procedure

48.5.7 Card insertion and removal detection

The SDHC uses either the DAT[3] pin or the CD pin to detect card insertion or removal. When there is no card on the MMC/SD bus, the DAT[3] will be pulled to a low voltage level by default. When any card is inserted to or removed from the socket, the SDHC detects the logic value changes on the DAT[3] pin and generates an interrupt. When the DAT[3] pin is not used for card detection (for example, it is implemented in GPIO), the CD pin must be connected for card detection. Whether DAT[3] is configured for card

detection or not, the CD pin is always a reference for card detection. Whether the DAT[3] pin or the CD pin is used to detect card insertion, the SDHC will send an interrupt (if enabled) to inform the Host system that a card is inserted.

48.5.8 Power management and wakeup events

When there is no operation between the SDHC and the card through the SD bus, the user can completely disable the bus clock and SDHC clock in the chip level clock control module to save power. When the user needs to use the SDHC to communicate with the card, it can enable the clock and start the operation.

In some circumstances, when the clocks to the SDHC are disabled, for instance, when the system is in low power mode, there are some events for which the user needs to enable the clock and handle the event. These events are called wakeup interrupts. The SDHC can generate these interrupt even when there are no clocks enabled. The three interrupts which can be used as wake up events are:

1. Card removal interrupt
2. Card insertion interrupt
3. Interrupt from SDIO card

The SDHC offers a power management feature. By clearing the clock enabled bits in the system control register, the clocks are gated in the low position to the SDHC. For maximum power saving, the user can disable all the clocks to the SDHC when there is no operation in progress.

These three wake up events (or wakeup interrupts) can also be used to wake up the system from low-power modes.

Note

To make the interrupt a wakeup event, when all the clocks to the SDHC are disabled or when the whole system is in low power mode, the corresponding wakeup enabled bit needs to be set. Refer to protocol control register for more information.

48.5.8.1 Setting wakeup events

For the SDHC to respond to a wakeup event, the software must set the respective wakeup enable bit before the CPU enters sleep mode. Before the software disables the host clock, it should ensure that all of the following conditions have been met:

- No read or write transfer is active
- Data and command lines are not active
- No interrupts are pending
- Internal data buffer is empty

48.5.9 MMC fast boot

In Embedded MultiMediaCard(eMMC4.3) spec, add fast boot feature need hardware support.

In boot operation mode, the master (multimediacard host) can read boot data from the slave (MMC device) by keeping CMD line low after power-on, or sending CMD0 with argument + 0xFFFFFFFFFA (optional for slave), before issuing CMD1.

There are two types of fast boot mode, ' boot operation ' and ' Alternative boot operation ' in eMMC4.3 spec. Each type also has with acknowledge and without acknowledge modes.

Note

for the eMMC4.3 card setting, please refer to eMMC4.3 spec

48.5.9.1 Boot operation

Note

in this block guide, this fast boot is called normal fast boot mode

If the CMD line is held low for 74 clock cycles and more after power-up before the first command is issued, the slave recognizes that boot mode is being initiated and starts preparing boot data internally.

Within 1 second after the CMD line goes low, the slave starts to send the first boot data to the master on the DAT line(s). The master must keep the CMD line low to read all of the boot data.

If boot acknowledge is enabled, the slave has to send acknowledge pattern '010' to the master within 50 ms after the CMD line goes low. If boot acknowledge is disabled, the slave will not send out acknowledge pattern '010'.

The master can terminate boot mode with the CMD line high.

Boot operation will be terminated when all contents of the enabled boot data are sent to the master. After boot operation is executed, the slave shall be ready for CMD1 operation and the master needs to start a normal MMC initialization sequence by sending CMD1.

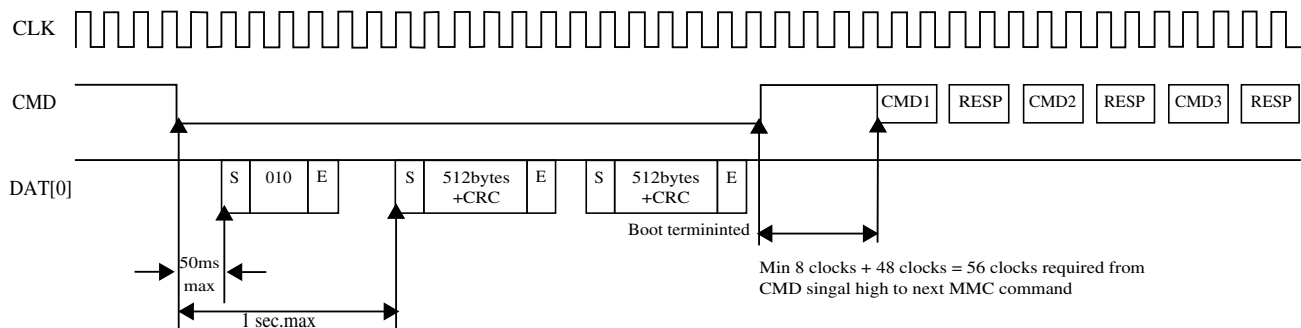

Figure 48-37. Multimediacard state diagram (normal boot mode)

48.5.9.2 Alternative boot operation

This boot function is optional for the device. If bit 0 in the extended CSD byte[228] is set to '1', the device supports the alternative boot operation.

After power-up, if the host issues CMD0 with the argument of 0xFFFFFFFFFA after 74 clock cycles, before CMD1 is issued or the CMD line goes low, the slave recognizes that boot mode is being initiated and starts preparing boot data internally.

Within 1 second after CMD0 with the argument of 0xFFFFFFFFFA is issued, the slave starts to send the first boot data to the master on the DAT line(s).

If boot acknowledge is enabled, the slave has to send the acknowledge pattern '010' to the master within 50ms after the CMD0 with the argument of 0xFFFFFFFFFA is received. If boot acknowledge is disabled, the slave will not send out acknowledge pattern '010'.

The master can terminate boot mode by issuing CMD0 (Reset).

Boot operation will be terminated when all contents of the enabled boot data are sent to the master. After boot operation is executed, the slave shall be ready for CMD1 operation and the master needs to start a normal MMC initialization sequence by sending CMD1.

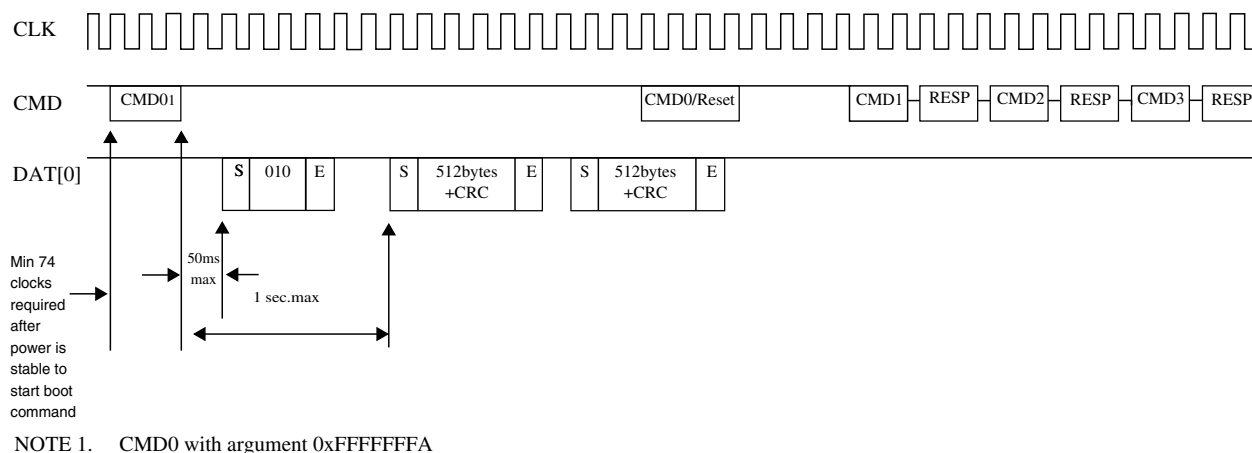

Figure 48-38. MultiMediaCard state diagram (alternative boot mode)

48.6 Initialization/application of SDHC

All communication between system and cards are controlled by the host. The host sends commands of two types: broadcast and addressed (point-to-point).

Broadcast commands are intended for all cards, such as "GO_IDLE_STATE", "SEND_OP_COND", "ALL_SEND_CID" and etc. In broadcast mode, all cards are in the open-drain mode to avoid bus contention. Refer to [Commands for MMC/SD/SDIO/CE-ATA](#) for the commands of bc and bcr categories.

After the broadcast command CMD3 is issued, the cards enter standby mode. Addressed type commands are used from this point. In this mode, the CMD/DAT I/O pads will turn to push-pull mode, to have the driving capability for maximum frequency operation. Refer to [Commands for MMC/SD/SDIO/CE-ATA](#) for the commands of ac and adtc categories.

48.6.1 Command send and response receive basic operation

Assuming the data type WORD is an unsigned 32-bit integer, the below flow is a guideline for sending a command to the card(s):

```
send_command(cmd_index, cmd_arg, other requirements)
{
    WORD wCmd; // 32-bit integer to make up the data to write into Transfer Type register, it is
    recommended to implement in a bit-field manner
    wCmd = (<cmd_index> & 0x3F) >> 24; // set the first 8 bits as '00'+<cmd_index>
    set CMDTYP, DPSEL, CICCEN, CCCEN, RSTTYP, DTDSEL accorind to the command_index;
    if (internal DMA is used) wCmd |= 0x1;
    if (multi-block transfer) {
        set MSBSEL bit;
        if (finite block number) {
```

Initialization/application of SDHC

```

    set BCEN bit;
    if (auto12 command is to use) set AC12EN bit;
}
}
write_reg(CMDARG, <cmd_arg>); // configure the command argument
write_reg(XFERTYP, wCmd); // set Transfer Type register as wCmd value to issue the command
}
wait_for_response(cmd_index)
{
while (CC bit in IRQ Status register is not set); // wait until Command Complete bit is set
read IRQ Status register and check if any error bits about Command are set
if (any error bits are set) report error;
write 1 to clear CC bit and all Command Error bits;
}

```

For the sake of simplicity, the function `wait_for_response` is implemented here by means of polling. For an effective and formal way, the response is usually checked after the command complete interrupt is received. By doing this, make sure the corresponding interrupt status bits are enabled.

For some scenarios, the response time-out is expected. For instance, after all cards respond to CMD3 and go to the standby state, no response to the host when CMD2 is sent. The host driver shall deal with 'fake' errors like this with caution.

48.6.2 Card identification mode

When a card is inserted to the socket or the card was reset by the host, the host needs to validate the operation voltage range, identify the cards, request the cards to publish the relative card address (RCA) or to set the RCA for the MMC cards. For CE-ATA, the device is connected in a point-to-point manner, and no RCA is needed. All data communications in the Card Identification Mode use the command line (CMD) only. Refer to CE-ATA Digital Protocol, Revision 1.1 for more details.

48.6.2.1 Card detect

The following diagram illustrates the detection of MMC, SD and SDIO cards using the SDHC.

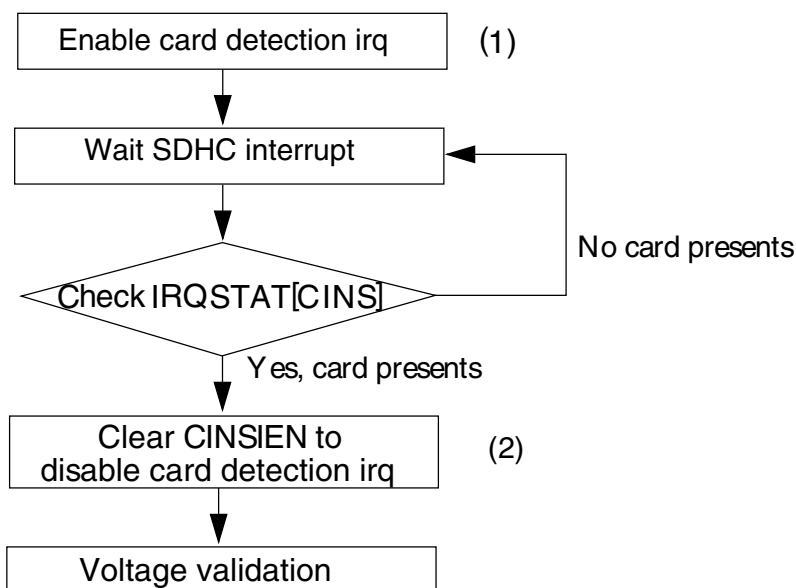

Figure 48-39. Flow diagram for card detection

Here is the card detection sequence:

- Set the CINSIEN bit to enable card detection interrupt
- When an interrupt from the SDHC is received, check the IRQSTAT[CINS] bit in the Interrupt Status register to see if it was caused by card insertion
- Clear the CINSIEN bit to disable the card detection interrupt and ignore all card insertion interrupts afterwards

To detect a CE-ATA device, after completing the normal MMC reset and initialization procedures, the host driver shall issue CMD 60 to check for a CE-ATA signature. If the device responds to the command with the CE-ATA signature, a CE-ATA device has been found. Then the driver should query EXT_CSD register byte 504 (S_CMD_SET) in the MMC register space. If the ATA bit (bit 4) is set, then the MMC device is an ATA device. If the device indicates that it is an ATA device, the Driver should set the ATA bit (bit 4) of the EXT_CSD register byte 191 (CMD_SET) to activate the ATA command set for use. To choose the command set, the driver shall issue CMD6. It is possible that the CE-ATA device does not support the ATA mode, so the driver shall not issue ATA command to the device.

48.6.2.2 Reset

The host consists of three types of resets:

- Hardware reset (card and host) which is driven by POR (power on reset)

- Software reset (host only) is proceed by the write operation on the SYSCTL[RSTD], SYSCTL[RSTC], or SYSCTL[RSTA] bits to reset the data part, command part, or all parts of the host controller, respectively
- Card reset (card only). The command, "Go_Idle_State" (CMD0), is the software reset command for all types of MMC cards, SD Memory cards, and CE-ATA cards. This command sets each card into the idle state regardless of the current card state. For an SD I/O Card, CMD52 is used to write an I/O reset in the CCCR. The cards are initialized with a default relative card address (RCA = 0x0000) and with a default driver stage register setting (lowest speed, highest driving current capability).

After the card is reset, the host needs to validate the voltage range of the card. The following diagram illustrates the software flow to reset both the SDHC and the card.

For CE-ATA device that supports ATA mode, before issuing CMD0 to reset the MMC layer, two CMD39 should be issued back-to-back to the ATA control register. The first CMD39 shall have the SRST bit set to one. The second CMD39 command shall have the SRST bit cleared to zero.

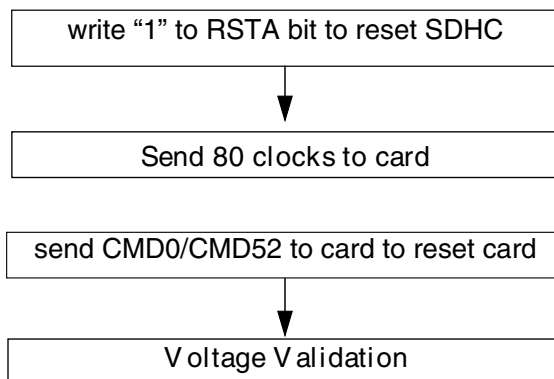

Figure 48-40. Flow chart for reset of the SDHC and SD I/O card

```

software_reset ()
{
set_bit(SYSCTRL, RSTA); // software reset the Host
set DTOCV and SDCLKFS bit fields to get the SD_CLK of frequency around 400kHz
configure IO pad to set the power voltage of external card to around 3.0V
poll bits CIHB and CDIHB bits of PRSSTAT to wait both bits are cleared
set_bit(SYSCTRL, INTIA); // send 80 clock ticks for card to power up
send_command(CMD_GO_IDLE_STATE, <other parameters>); // reset the card with CMD0
or send_command(CMD_IO_RW_DIRECT, <other parameters>);
}
  
```

48.6.2.3 Voltage validation

All cards should be able to establish communication with the host using any operation voltage in the maximum allowed voltage range specified in the card specification. However, the supported minimum and maximum values for V_{DD} are defined in the Operation Conditions Register (OCR) and may not cover the whole range. Cards that store the CID and CSD data in the preload memory are only able to communicate this information under data transfer V_{DD} conditions. This means if the host and card have non-common V_{DD} ranges, the card will not be able to complete the identification cycle, nor will it be able to send CSD data.

Therefore, a special command `Send_Op_Cont` (CMD1 for MMC), `SD_Send_Op_Cont` (ACMD41 for SD Memory) and `IO_Send_Op_Cont` (CMD5 for SD I/O) is used. For a CE-ATA card, the process is the same as that of an MMC card. The voltage validation procedure is designed to provide a mechanism to identify and reject cards which do not match the V_{DD} range(s) desired by the host. This is accomplished by the host sending the desired V_{DD} voltage window as the operand of this command. Cards that can't perform the data transfer in the specified range must discard themselves from further bus operations and go into the Inactive State. By omitting the voltage range in the command, the host can query each card and determine the common voltage range before sending out-of-range cards into the inactive state. This query should be used if the host is able to select a common voltage range or if a notification shall be sent to the system when a non-usable card in the stack is detected.

The following steps show how to perform voltage validation when a card is inserted:

```

voltage_validation(voltage_range_argument)
{
label the card as UNKNOWN;
send_command(IO_SEND_OP_COND, 0x0, <other parameters are omitted>); // CMD5, check SDIO
operation voltage, command argument is zero
if (RESP_TIMEOUT != wait_for_response(IO_SEND_OP_COND)) { // SDIO command is accepted
    if (0 < number of IO functions) {
        label the card as SDIO;
        IORDY = 0;
        while (!(IORDY in IO OCR response)) { // set voltage range for each IO function
            send_command(IO_SEND_OP_COND, <voltage range>, <other parameter>);
            wait_for_response(IO_SEND_OP_COND);
        } // end of while ...
    } // end of if (0 < ...
    if (memory part is present inside SDIO card) Label the card as SDCombo; // this is an
SD-Combo card
} // end of if (RESP_TIMEOUT ...
if (the card is labelled as SDIO card) return; // card type is identified and voltage range
is
set, so exit the function;
send_command(APP_CMD, 0x0, <other parameters are omitted>); // CMD55, Application specific
CMD
prefix
if (no error calling wait_for_response(APP_CMD, <...>) { // CMD55 is accepted
    send_command(SD_APP_OP_COND, <voltage range>, <...>); // ACMD41, to set voltage range
for memory part or SD card
    wait_for_response(SD_APP_OP_COND); // voltage range is set
    if (card type is UNKNOWN) label the card as SD;
}
}

```

```

return; //
} // end of if (no error ...
else if (errors other than time-out occur) { // command/response pair is corrupted
deal with it by program specific manner;
} // of else if (response time-out
else { // CMD55 is refuse, it must be MMC card or CE-ATA card
if (card is already labelled as SDCombo) { // change label
re-label the card as SDIO;
ignore the error or report it;
return; // card is identified as SDIO card
} // of if (card is ...
send_command(SEND_OP_COND, <voltage range>, <...>);
if (RESP_TIMEOUT == wait_for_response(SEND_OP_COND)) { // CMD1 is not accepted, either
label the card as UNKNOWN;
return;
} // of if (RESP_TIMEOUT ...
if (check for CE-ATA signature succeeded) { // the card is CE-ATA
store CE-ATA specific info from the signature;
label the card as CE-ATA;
} // of if (check for CE-ATA ...
else label the card as MMC;
} // of else
}

```

48.6.2.4 Card registry

Card registry for the MMC and SD/SDIO/SD combo cards are different. For CE-ATA, it enters the tran state after reset is completed.

For the SD card, the identification process starts at a clock rate lower than 400 kHz and the power voltage higher than 2.7 V (as defined by the card specification). At this time, the CMD line output drives are push-pull drivers instead of open-drain. After the bus is activated, the host will request the card to send their valid operation conditions. The response to ACMD41 is the operation condition register of the card. The same command shall be send to all of the new cards in the system. Incompatible cards are put into the inactive state. The host then issues the command, All_Send_CID (CMD2), to each card to get its unique card identification (CID) number. Cards that are currently unidentified (in the ready state), send their CID number as the response. After the CID is sent by the card, the card goes into the identification state.

The host then issues Send_Relative_Addr (CMD3), requesting the card to publish a new relative card address (RCA) that is shorter than the CID. This RCA will be used to address the card for future data transfer operations. Once the RCA is received, the card changes its state to the standby state. At this point, if the host wants the card to have an alternative RCA number, it may ask the card to publish a new number by sending another Send_Relative_Addr command to the card. The last published RCA is the actual RCA of the card.

The host repeats the identification process with CMD2 and CMD3 for each card in the system until the last CMD2 gets no response from any of the cards in system.

For MMC operation, the host starts the card identification process in open-drain mode with the identification clock rate lower than 400 kHz and the power voltage higher than 2.7 V. The open drain driver stages on the CMD line allow parallel card operation during card identification. After the bus is activated the host will request the cards to send their valid operation conditions (CMD1). The response to CMD1 is the "wired OR" operation on the condition restrictions of all cards in the system. Incompatible cards are sent into the inactive state. The host then issues the broadcast command All_Send_CID (CMD2), asking all cards for their unique card identification (CID) number. All unidentified cards (the cards in ready state) simultaneously start sending their CID numbers serially, while bit-wise monitoring their outgoing bit stream. Those cards, whose outgoing CID bits do not match the corresponding bits on the command line in any one of the bit periods, stop sending their CID immediately and must wait for the next identification cycle. Since the CID is unique for each card, only one card can be successfully send its full CID to the host. This card then goes into the identification state. Thereafter, the host issues Set_Relative_Addr (CMD3) to assign to the card a relative card address (RCA). Once the RCA is received the card state changes to the standby state, and the card does not react in further identification cycles, and its output driver switches from open-drain to push-pull. The host repeats the process, mainly CMD2 and CMD3, until the host receives a time-out condition to recognize the completion of the identification process.

For CE-ATA operation (same interface as MMC cards):

```
card_registry()
{
do { // decide RCA for each card until response time-out
  if(card is labelled as SDCCombo or SDIO) { // for SDIO card like device
    send_command(SET_RELATIVE_ADDR, 0x00, <...>); // ask SDIO card to publish its
RCA
    retrieve RCA from response;
  } // end if (card is labelled as SDCCombo ...
  else if (card is labelled as SD) { // for SD card
    send_command(ALL_SEND_CID, <...>);
    if (RESP_TIMEOUT == wait_for_response(ALL_SEND_CID)) break;
    send_command(SET_RELATIVE_ADDR, <...>);
    retrieve RCA from response;
  } // else if (card is labelled as SD ...
  else if (card is labelled as MMC or CE-ATA) { // treat CE-ATA as MMC
    send_command(ALL_SEND_CID, <...>);
    rca = 0x1; // arbitrarily set RCA, 1 here for example, this RCA is also the
relative address to access the CE-ATA card
    send_command(SET_RELATIVE_ADDR, 0x1 << 16, <...>); // send RCA at upper 16
bits
  } // end of else if (card is labelled as MMC ...
} while (response is not time-out);
}
```

48.6.3 Card access

This section discusses the various card access methods.

48.6.3.1 Block write

This section discusses the block write access methods.

48.6.3.1.1 Normal write

During a block write (CMD24 - 27, CMD60, CMD61), one or more blocks of data are transferred from the host to the card with a CRC appended to the end of each block by the host. If the CRC fails, the card shall indicate the failure on the DAT line. The transferred data will be discarded and not written, and all further transmitted blocks (in multiple block write mode) will be ignored.

If the host uses partial blocks whose accumulated length is not block aligned and block misalignment is not allowed (CSD parameter WRITE_BLK_MISALIGN is not set, and the CE-ATA card does not support partial block write, either), the card detects the block misalignment error and aborts the programming before the beginning of the first misaligned block. The card sets the ADDRESS_ERROR error bit in the status register, and while ignoring all further data transfer, waits in the Receive-data-State for a stop command. For a CE-ATA card, check the CE-ATA card specification for its behavior in block misalignment. The write operation is also aborted if the host tries to write over a write protected area.

For MMC and SD cards, programming of the CID and CSD registers does not require a previous block length setting. The transferred data is also CRC protected. If a part of the CSD or CID register is stored in ROM, then this unchangeable part must match the corresponding part of the receive buffer. If this match fails, then the card will report an error and not change any register contents.

For all types of cards, some may require long and unpredictable periods of time to write a block of data. After receiving a block of data and completing the CRC check, the card will begin writing and hold the DAT line low if its write buffer is full and unable to accept new data from a new WRITE_BLOCK command. The host may poll the status of the card with a SEND_STATUS command (CMD13) or other means for SDIO and CE-ATA cards at any time, and the card will respond with its status. The responded status indicates whether the card can accept new data or whether the write process is still in progress. The host may deselect the card by issuing a CMD7 (to select a different card) to place the card into the Standby State and release the DAT line without interrupting the write operation. When re-selecting the card, it will reactivate the busy indication by pulling DAT to low if the programming is still in progress and the write buffer is unavailable.

The software flow to write to a card incorporates the internal DMA and the write operation is a multi-block write with the Auto CMD12 enabled. For the other two methods (by means of external DMA or CPU polling status) with different transfer methods, the internal DMA parts should be removed and the alternative steps should be straightforward.

The software flow to write to a card is described below:

1. Check the card status, wait until the card is ready for data.
2. Set the card block length/size:
 - a. For SD/MMC cards, use SET_BLOCKLEN (CMD16)
 - b. For SDIO cards or the I/O portion of SDCombo cards, use IO_RW_DIRECT (CMD52) to set the I/O Block Size bit field in the CCCR register (for function 0) or FBR register (for functions 1~7)
 - c. For CE-ATA cards, configure bits 1~0 in the scrControl register
3. Set the eSDHC block length register to be the same as the block length set for the card in Step 2.
4. Set the eSDHC number block register (NOB), nob is 5 (for instance).
5. Disable the buffer write ready interrupt, configure the DMA settings and enable the eSDHC DMA when sending the command with data transfer. The AC12EN bit should also be set.
6. Wait for the Transfer Complete interrupt.
7. Check the status bit to see if a write CRC error occurred, or some another error, that occurred during the auto12 command sending and response receiving.

48.6.3.1.2 Write with pause

The write operation can be paused during the transfer. Instead of stopping the SD_CLK at any time to pause all the operations, which is also inaccessible to the host driver, the driver can set the PROCTL[SABGREQ] to pause the transfer between the data blocks. As there is no time-out condition in a write operation during the data blocks, a write to all types of cards can be paused in this way, and if the DAT0 line is not required to de-assert to release the busy state, no suspend command is needed.

Like in the flow described in [Normal write](#), the write with pause is shown with the same kind of write operation:

1. Check the card status, wait until card is ready for data.
2. Set the card block length/size:
 - a. For SD/MMC, use SET_BLOCKLEN (CMD16)
 - b. For SDIO cards or the I/O portion of SDCombo cards, use IO_RW_DIRECT(CMD52) to set the I/O Block Size bit field in the CCCR register (for function 0) or FBR register (for functions 1~7)
 - c. For CE-ATA cards, configure bits 1~0 in the scrControl register
3. Set the SDHC block length register to be the same as the block length set for the card in Step 2.
4. Set the SDHC number block register (NOB), nob is 5 (for instance).
5. Disable the buffer write ready interrupt, configure the DMA settings and enable the SDHC DMA when sending the command with data transfer. The XFERTYP[AC12EN] bit should also be set.
6. Set the PROCTL[SABGREQ] bit.
7. Wait for the transfer complete interrupt.
8. Clear the PROCTL[SABGREQ] bit.
9. Check the status bit to see if a write CRC error occurred.
10. Set the PROCTL[CREQ] bit to continue the write operation.
11. Wait for the transfer complete interrupt.
12. Check the status bit to see if a write CRC error occurred, or some another error, that occurred during the auto12 command sending and response receiving.

The number of blocks left during the data transfer is accessible by reading the contents of the BLKATTR[BLKCNT] . As the data transfer and the setting of the PROCTL[SABGREQ] bit are concurrent, and the delay of register read and the register setting, the actual number of blocks left may not be exactly the value read earlier. The driver shall read the value of BLKATTR[BLKCNT] after the transfer is paused and the transfer complete interrupt is received.

It is also possible the last block has begun when the stop at block gap request is sent to the buffer. In this case, the next block gap is actually the end of the transfer. These types of requests are ignored and the Driver should treat this as a non-pause transfer and deal with it as a common write operation.

When the write operation is paused, the data transfer inside the host system is not stopped, and the transfer is active until the data buffer is full. Because of this (if not needed), it is recommended to avoid using the suspend command for the SDIO card. This is because when such a command is sent, the SDHC thinks the system will switch to another function on the SDIO card, and flush the data buffer. The SDHC takes the resume command as a normal command with data transfer, and it is left for the driver to set all the relevant registers before the transfer is resumed. If there is only one block to send when the transfer is resumed, the XFERTYP[MSBSEL] and XFERTYP[BCEN] bits are set as well as the XFERTYP[AC12EN] bit. However, the SDHC will automatically send a CMD12 to mark the end of the multi-block transfer.

48.6.3.2 Block read

This section discusses the block read access methods.

48.6.3.2.1 Normal read

For block reads, the basic unit of data transfer is a block whose maximum size is stored in areas defined by the corresponding card specification. A CRC is appended to the end of each block, ensuring data transfer integrity. The CMD17, CMD18, CMD53, CMD60, CMD61, and so on, can initiate a block read. After completing the transfer, the card returns to the transfer state. For multi blocks read, data blocks will be continuously transferred until a stop command is issued.

The software flow to read from a card incorporates the internal DMA and the read operation is a multi-block read with the Auto CMD12 enabled. For the other two methods (by means of external DMA or CPU polling status) with different transfer methods, the internal DMA parts should be removed and the alternative steps should be straightforward.

The software flow to read from a card is described below:

1. Check the card status, wait until card is ready for data.
2. Set the card block length/size:
 - a. For SD/MMC, use SET_BLOCKLEN (CMD16)
 - b. For SDIO cards or the I/O portion of SDCombo cards, use IO_RW_DIRECT(CMD52) to set the I/O block size bit field in the CCCR register (for function 0) or FBR register (for functions 1~7)
 - c. For CE-ATA cards, configure bits 1~0 in the scrControl register

3. Set the SDHC block length register to be the same as the block length set for the card in Step 2.
4. Set the SDHC number block register (NOB), nob is 5 (for instance).
5. Disable the buffer read ready interrupt, configure the DMA settings and enable the SDHC DMA when sending the command with data transfer. The XFERTYP[AC12EN] bit should also be set:
6. Wait for the transfer complete interrupt.
7. Check the status bit to see if a read CRC error occurred, or some another error, occurred during the auto12 command sending and response receiving.

48.6.3.2.2 Read with pause

The read operation is not generally able to pause. Only the SDIO card (and SDCombo card working under I/O mode) supporting the read and wait feature can pause during the read operation. If the SDIO card support read wait (SRW bit in CCCR register is 1), the Driver can set the SABGREQ bit in the Protocol Control register to pause the transfer between the data blocks. Before setting the SABGREQ bit, make sure the RWCTL bit in the Protocol Control register is set, otherwise the eSDHC will not assert the Read Wait signal during the block gap and data corruption occurs. It is recommended to set the RWCTL bit once the Read Wait capability of the SDIO card is recognized.

Like in the flow described in [Normal read](#), the read with pause is shown with the same kind of read operation:

1. Check the SRW bit in the CCR register on the SDIO card to confirm the card supports Read Wait.
2. Set the RWCTL bit.
3. Check the card status and wait until the card is ready for data.
4. Set the card block length/size:
 - a. For SD/MMC, use SET_BLOCKLEN (CMD16)
 - b. For SDIO cards or the I/O portion of SDCombo cards, use IO_RW_DIRECT(CMD52) to set the I/O Block Size bit field in the CCCR register (for function 0) or FBR register (for functions 1~7)
 - c. For CE-ATA cards, configure bits 1~0 in the scrControl register

5. Set the SDHC block length register to be the same as the block length set for the card in Step 2.
6. Set the SDHC number block register (NOB), nob is 5 (for instance).
7. Disable the buffer read ready interrupt, configure the DMA setting and enable the eSDHC DMA when sending the command with data transfer. The AC12EN bit should also be set
8. Set the SABGREQ bit.
9. Wait for the Transfer Complete interrupt.
10. Clear the SABGREQ bit.
11. Check the status bit to see if read CRC error occurred.
12. Set the CREQ bit to continue the read operation.
13. Wait for the Transfer Complete interrupt.
14. Check the status bit to see if a read CRC error occurred, or some another error, occurred during the auto12 command sending and response receiving.

Like the write operation, it is possible to meet the ending block of the transfer when paused. In this case, the SDHC will ignore the Stop At Block Gap Request and treat it as a command read operation.

Unlike the write operation, there is no remaining data inside the buffer when the transfer is paused. All data received before the pause will be transferred to the Host System. No matter if the Suspend Command is sent or not, the internal data buffer is not flushed.

If the Suspend Command is sent and the transfer is later resumed by means of a Resume Command, the SDHC takes the command as a normal one accompanied with data transfer. It is left for the Driver to set all the relevant registers before the transfer is resumed. If there is only one block to send when the transfer is resumed, the MSBSEL and BCEN bits of the Transfer Type register are set, as well as the AC12EN bit. However, the SDHC will automatically send the CMD12 to mark the end of multi-block transfer.

48.6.3.3 Suspend resume

The SDHC supports the suspend resume operations of SDIO cards, although slightly different than the suggested implementation of Suspend in the SDIO card specification..

48.6.3.3.1 Suspend

After setting the PROCTL[SABGREQ] bit, the host driver may send a suspend command to switch to another function of the SDIO card. The SDHC does not monitor the content of the response, so it doesn't know if the suspend command succeeded or not.

Accordingly, it doesn't de-assert read wait for read pause. To solve this problem, the driver shall not mark the suspend command as a "suspend", (i.e. setting the XFERTYP[CMDTYP] bits to 01). Instead, the driver shall send this command as if it were a normal command, and only when the command succeeds, and the BS bit is set in the response, can the driver send another command marked as "suspend" to inform the SDHC that the current transfer is suspended. As shown in the following sequence for suspend operation:

1. Set the PROCTL[SABGREQ] bit to pause the current data transfer at block gap.
2. After the IRQSTAT[BGE] bit is set, send the suspend command to suspend the active function. The XFERTYP[CMDTYP] bit field must be 2'b00.
3. Check the BS bit of the CCCR in the response. If it is 1, repeat this step until the BS bit is cleared or abandon the suspend operation according to the Driver strategy.
4. Send another normal I/O command to the suspended function. The XFERTYP[CMDTYP] of this command must be 2'b01, so the SDHC can detect this special setting and be informed that the paused operation has successfully suspended. If the paused transfer is a read operation, the SDHC stops driving DAT2 and goes to the idle state.
5. Save the context registers in the system memory for later use, including the DMA system address register (for internal DMA operation), and the block attribute register.
6. Begin operation for another function on the SDIO card.

48.6.3.3.2 Resume

To resume the data transfer, a resume command shall be issued:

1. To resume the suspended function, restore the context register with the saved value in step #5 of the suspend operation above.
2. Send the resume command. In the transfer type register, all bit fields are set to the value as if this were another ordinary data transfer, instead of a transfer resume (except the CMDTYP is set to 2'b10).
3. If the resume command has responded, the data transfer will be resumed.

48.6.3.4 ADMA usage

To use the ADMA in a data transfer, the host driver must prepare the correct descriptor chain prior to sending the read/write command. The steps to accomplish this are:

1. Create a descriptor to set the data length that the current descriptor group is about to transfer. The data length should be even numbers of the block size.
2. Create another descriptor to transfer the data from the address setting in this descriptor. The data address must be at a page boundary (4 KB address aligned).
3. If necessary, create a link descriptor containing the address of the next descriptor. The descriptor group is created in steps 1 ~ 3.
4. Repeat steps 1 ~ 3 until all descriptors are created.
5. In the last descriptor, set the end flag to 1 and make sure the total length of all descriptors match the product of the block size and block number configured in the BLKATTR register.
6. Set the DSADDR register to the address of the first descriptor and set the PROCTL[DMAS] field to 01 to select the ADMA.
7. Issue a write or read command with the XFERTYP[DMAEN] bit set to 1.

Steps 1 ~ 5 are independent of step 6, so step 6 can finish before steps 1 ~ 5. Regarding the descriptor configuration, it is recommended not to use the link descriptor as it requires extra system memory access.

48.6.3.5 Transfer error

This section discusses the handling of transfer errors.

48.6.3.5.1 CRC error

It is possible at the end of a block transfer, that a write CRC status error or read CRC error occurs. For this type of error the latest block received shall be discarded. This is because the integrity of the data block is not guaranteed. It is recommended to discard the following data blocks and re-transfer the block from the corrupted one. For a multi-block transfer, the host driver shall issue a CMD12 to abort the current process and start the transfer by a new data command. In this scenario, even when the XFERTYP[AC12EN] and BCEND bits are set, the SDHC does not automatically send a CMD12 because the

last block is not transferred. On the other hand, if it is within the last block that the CRC error occurs, an auto CMD12 will be sent by the SDHC. In this case, the driver shall re-send or re-obtain the last block with a single block transfer.

48.6.3.5.2 Internal DMA error

During the data transfer with internal simple DMA, if the DMA engine encounters some error on the system bus, the DMA operation is aborted and DMA error interrupt is sent to the host system. When acknowledged by such an interrupt, the driver shall calculate the start address of data block in which the error occurs. The start address can be calculated by either:

1. Read the DMA system address register. The error occurs during the previous burst. Taking the block size, the previous burst length and the start address of the next burst transfer into account, it is straight forward to obtain the start address of the corrupted block.
2. Read the BLKCNT field of the block attribute register. By the number of blocks left, the total number to transfer, the start address of transfer, and the size of each block, the start address of corrupted block can be determined. When the BCEN bit is not set, the contents of the block attribute register does not change, so this method does not work.

When a DMA error occurs, it is recommended to abort the current transfer by means of a CMD12 (for multi block transfer), apply a reset for data, and re-start the transfer from the corrupted block to recover from the error.

48.6.3.5.3 ADMA error

There are three kinds of possible ADMA errors. The transfer, invalid descriptor, and data-length mismatch errors. Whenever these errors occur, the DMA transfer stops and the corresponding error status bit is set. For acknowledging the status, the host driver should recover the error as shown below and re-transfer from the place of interruption.

1. Transfer error: Such errors may occur during data transfer or descriptor fetch. For either scenario, it is recommended to retrieve the transfer context, reset for the data part and re-transfer the block that was corrupted, or the next block if no block is corrupted.

2. Invalid descriptor error: For such errors, it is recommended to retrieve the transfer context, reset for the data part and re-create the descriptor chain from the invalid descriptor and issue a new transfer. As the data to transfer now may be less than the previous setting, the data length configured in the new descriptor chain should match the new value.
3. Data-length mismatch error: It is similar to recover from this error. The host driver polls relating registers to retrieve the transfer context, apply a reset for the data part, configure a new descriptor chain, and make another transfer if there is data left. Like the previous scenario of the invalid descriptor error, the data length must match the new transfer.

48.6.3.5.4 Auto CMD12 error

After the last block of the multi block transfer is sent or received, and the XFERTYP[AC12EN] bit is set when the data transfer is initiated by the data command, the SDHC automatically sends a CMD12 to the card to stop the transfer. When errors with this command occur, it is recommended to the driver to deal with the situations in the following manner:

1. Auto CMD12 response time-out. It is not certain whether the command is accepted by the card or not. The driver should clear the IRQSTAT[AC12E] bits and re-send the CMD12 until it is accepted by the card.
2. Auto CMD12 response CRC error. Since card responds to the CMD12, the card will abort the transfer. The driver may ignore the error and clear the IRQSTAT[AC12E] bit.
3. Auto CMD12 conflict error or not sent. The command is not sent, so the driver shall send a CMD12 manually.

48.6.3.6 Card interrupt

The external cards can inform the host controller by means of some special signals. For the SDIO card, it can be the low level on the DAT[1] line during some special period. For the CE-ATA card, it can be a pulse on the CMD line to inform the host controller that the command and its response is finished, and it is possible that some additional external interrupt behaviors are defined. The SDHC only monitors the DAT[1] line and supports the SDIO interrupt.

When the SDIO interrupt is captured by the SDHC, and the host system is informed by the SDHC asserting the SDHC interrupt line, the interrupt service from the host driver is called.

As the interrupt factor is controlled by the external card, the interrupt from the SDIO card must be served before the IRQSTAT[CINT] bit is cleared by written 1. Refer to [Card interrupt handling](#) for the card interrupt handling flow.

48.6.4 Switch function

MMC cards transferring data at bus widths other than 1-bit is a new feature added to the MMC specifications. The high speed timing mode for all card devices, was also recently defined in various card specifications. To enable these new features, a "switch" command shall be issued by the host driver.

For SDIO cards, the high speed mode is enabled by writing the EHS bit in the CCCR register after the SHS bit is confirmed. For SD cards, the high speed mode is queried and enabled by a CMD6 (with the mnemonic symbol as SWITCH_FUNC). For MMC cards (and CE-ATA over MMC interface), the high speed mode is queried by a CMD8 and enabled by a CMD6 (with the mnemonic symbol as SWITCH).

The 4-bit and 8-bit bus width of the MMC is also enabled by the SWITCH command, but with a different argument.

These new functions can also be disabled by a software reset. For SDIO cards it can be done by setting the RES bit in the CCCR register. For other cards, it can be accomplished by issuing a CMD0. This method of restoring to the normal mode is not recommended because a complete identification process is needed before the card is ready for data transfer.

For the sake of simplicity, the following flowcharts do not show current capability check, which is recommended in the function switch process.

48.6.4.1 Query, enable and disable SDIO high speed mode

```
enable_sdio_high_speed_mode(void)
{
send CMD52 to query bit SHS at address 0x13;
if (SHS bit is '0') report the SDIO card does not support high speed mode and return;
send CMD52 to set bit EHS at address 0x13 and read after write to confirm EHS bit is set;
change clock divisor value or configure the system clock feeding into eSDHC to generate the
card_clk of around 50MHz;
(data transactions like normal peers)
}
disable_sdio_high_speed_mode(void)
{
```

```

send CMD52 to clear bit EHS at address 0x13 and read after write to confirm EHS bit is
cleared;
change clock divisor value or configure the system clock feeding into eSDHC to generate the
card_clk of the desired value below 25MHz;
(data transactions like normal peers)
}

```

48.6.4.2 Query, enable and disable SD high speed mode

```

enable_sd_high_speed_mode(void)
{
set BLKCNT field to 1 (block), set BLKSIZE field to 64 (bytes);
send CMD6, with argument 0xFFFFF1 and read 64 bytes of data accompanying the R1 response;
wait data transfer done bit is set;
check if the bit 401 of received 512 bit is set;
if (bit 401 is '0') report the SD card does not support high speed mode and return;
send CMD6, with argument 0x80FFFFF1 and read 64 bytes of data accompanying the R1 response;
check if the bit field 379~376 is 0xF;
if (the bit field is 0xF) report the function switch failed and return;
change clock divisor value or configure the system clock feeding into eSDHC to generate the
card_clk of around 50MHz;
(data transactions like normal peers)
}
disable_sd_high_speed_mode(void)
{
set BLKCNT field to 1 (block), set BLKSIZE field to 64 (bytes);
send CMD6, with argument 0x80FFFFF0 and read 64 bytes of data accompanying the R1 response;
check if the bit field 379~376 is 0xF;
if (the bit field is 0xF) report the function switch failed and return;
change clock divisor value or configure the system clock feeding into eSDHC to generate the
card_clk of the desired value below 25MHz;
(data transactions like normal peers)
}

```

48.6.4.3 Query, enable and disable MMC high speed mode

```

enable_mmc_high_speed_mode(void)
{
send CMD9 to get CSD value of MMC;
check if the value of SPEC_VER field is 4 or above;
if (SPEC_VER value is less than 4) report the MMC does not support high speed mode and
return;
set BLKCNT field to 1 (block), set BLKSIZE field to 512 (bytes);
send CMD8 to get EXT_CSD value of MMC;
extract the value of CARD_TYPE field to check the 'high speed mode' in this MMC is 26MHz or
52MHz;
send CMD6 with argument 0x1B90100;
send CMD13 to wait card ready (busy line released);
send CMD8 to get EXT_CSD value of MMC;
check if HS_TIMING byte (byte number 185) is 1;
if (HS_TIMING is not 1) report MMC switching to high speed mode failed and return;
change clock divisor value or configure the system clock feeding into eSDHC to generate the
card_clk of around 26MHz or 52MHz according to the CARD_TYPE;
(data transactions like normal peers)
}
disable_mmc_high_speed_mode(void)
{
send CMD6 with argument 0x2B90100;
set BLKCNT field to 1 (block), set BLKSIZE field to 512 (bytes);
send CMD8 to get EXT_CSD value of MMC;
check if HS_TIMING byte (byte number 185) is 0;
}

```

Initialization/application of SDHC

```

if (HS_TIMING is not 0) report the function switch failed and return;
change clock divisor value or configure the system clock feeding into eSDHC to generate the
card_clk of the desired value below 20MHz;
(data transactions like normal peers)
}

```

48.6.4.4 Set MMC bus width

```

change_mmc_bus_width(void)
{
send CMD9 to get CSD value of MMC;
check if the value of SPEC_VER field is 4 or above;
if (SPEC_VER value is less than 4) report the MMC does not support multiple bit width and
return;
send CMD6 with argument 0x3B70x00; (8-bit, x=2; 4-bit, x=1; 1-bit, x=0)
send CMD13 to wait card ready (busy line released);
(data transactions like normal peers)
}

```

48.6.5 ADMA operation

This section presents code examples for ADMA operation.

48.6.5.1 ADMA1 operation

```

Set_adma1_descriptor
{
    if (to start data transfer) {
        // Make sure the address is 4KB align.
        Set 'Set' type descriptor;
        {
            Set Act bits to 01;
            Set [31:12] bits data length (byte unit);
        }
        Set 'Tran' type descriptor;
        {
            Set Act bits to 10;
            Set [31:12] bits address (4KB align);
        }
    }
    else if (to fetch descriptor at non-continuous address) {
        Set Act bits to 11;
        Set [31:12] bits the next descriptor address (4KB align);
    }
    else { // other types of descriptor
        Set Act bits accordingly
    }
    if (this descriptor is the last one) {
        Set End bit to 1;
    }
    if (to generate interrupt for this descriptor) {
        Set Int bit to 1;
    }
    Set Valid bit to 1;
}

```

48.6.5.2 ADMA2 operation

```

Set_adma2_descriptor
{
    if (to start data transfer) {
        // Make sure the address is 32-bit boundary (lower 2-bit are always '00').
        Set higher 32-bit of descriptor for this data transfer initial address;
        Set [31:16] bits data length (byte unit);
        Set Act bits to '10';
    }
    else if (to fetch descriptor at non-continuous address) {
        Set Act bits to '11';
        // Make sure the address is 32-bit boundary (lower 2-bit are always set to '00').
        Set higher 32-bit of descriptor for the next descriptor address;
    }
    else { // other types of descriptor
        Set Act bits accordingly
    }
    if (this descriptor is the last one) {
        Set 'End' bit '1';
    }
    if (to generate interrupt for this descriptor) {
        Set 'Int' bit '1';
    }
    Set the 'Valid' bit to '1';
}

```

48.6.6 Fast boot operation

This section discusses fast boot operations.

48.6.6.1 Normal fast boot flow

1. Software need to configure SYSCTL[INITA] to make sure 74 card clocks are finished.
2. Software need to configure MMCBOOT[BOOTEN] to 1, and MMCBOOT[BOOTMODE] to 0, and MMCBOOT[BOOTACK] to select the ack mode or not. If need to send through DMA mode, need to configure MMCBOOT[AUTOSABGEN] to enable automatically stop at block gap feature. And need to configure MMCBOOT[DTOCVACK] to select the ack timeout value according to the sd clk frequence.
3. Software then need to configure BLKATTR register to set block size/no.
4. Software need to configure PROCTL[DTW].
5. Software need to configure CMDARG to set argument if needed(no need in normal fast boot).

6. Software need to configure XFERTYP register to start the boot process . In normal boot mode, XFERTYP[CMDINX], XFERTYP[CMDTYP], XFERTYP[RSPTYP], XFERTYP[CICEN], XFERTYP[CCEN], XFERTYP[AC12EN], XFERTYP[BCEN] and XFERTYP[DMAEN] are kept default value. XFERTYP[DPSEL] bit is set to 1, XFERTYP[DTDSEL] is set to 1, XFERTYP[MSBSEL] is set to 1. Note XFERTYP[DMAEN] should be configured as 0 in polling mode. And if XFERTYP[BCEN] is configured as 1, better to configure BLKATTR[BLKSIZE] to the max value.
7. When the step 6 is configured, boot process will begin. Software need to poll the data buffer ready status to read the data from buffer in time. If boot time-out happened(ack time out or the first data read time out), Interrupt will be triggered, and software need to configure MMCBOOT[BOOTEN] to 0 to disable boot. Thus will make CMD high, and then after at least 56 clocks, it is ready to begin normal initialization process.
8. If no time out, software need to decide the data read is finished and then configure MMCBOOT[BOOTEN] to 0 to disable boot. This will make CMD line high and command completed asserted. After at least 56 clocks, it is ready to begin normal initialization process.
9. Reset the host and then can begin the normal process.

48.6.6.2 Alternative fast boot flow

1. Software need to configure init_active bit (system control register bit 27) to make sure 74 card clocks are finished.
2. Software need to configure MMCBOOT [BOOTEN] to 1, and MMCBOOT [BOOTMODE] to 1, and MMCBOOT [BOOTACK] to select the ack mode or not. If need to send through DMA mode, need to configure MMCBOOT [AUTOSABGEN] to enable automatically stop at block gap feature. And need to configure MMCBOOT [DTCVACK] to select the ack timeout value according to the sd clk frequency.
3. Software then need to configure BLKATTR register to set block size/no.
4. Software need to configure PROCTL[DTW].
5. Software need to configure CMDARG register to set argument to 0xFFFFFFFFFA.
6. Software need to configure XFERTYP register to start the boot process by CMD0 with 0xFFFFFFFFFA argument . In alternative boot, CMDINX, CMDTYP, RSPTYP, CICEN, CCEN, AC12EN, BCEN and DMAEN are kept default value. DPSEL bit

is set to 1, DTDSEL is set to 1, MSBSEL is set to 1. Note DMAEN should be configured as 0 in polling mode. And if BCEN is configured as 1 in polling mode, better to configure blk no in Block Attributes Register to the max value.

7. When the step 6 is configured, boot process will begin. Software need to poll the data buffer ready status to read the data from buffer in time. If boot time out (ack data time out in 50ms or data time out in 1s), host will send out the interrupt and software need to send CMD0 with reset and then configure boot enable bit to 0 to stop this process. After command completed, configure MMCBOOT[BOOTEN] to 0 to disable boot. After at least 8 clocks from command completed, card is ready for identification step.
8. If no time out, software need to decide when to stop the boot process, and send out the CMD0 with reset and then after command completed, configure MMCBOOT[BOOTEN] to stop the process. After 8 clocks from command completed, slave(card) is ready for identification step.
9. Reset the host and then can begin the normal process.

48.6.6.3 Fast boot application case (in DMA mode)

In the boot application case, because the image destination and the image size are contained in the

beginning of the image, need to switch DMA parameters on the fly during MMC fast boot.

In fast boot, host can use ADMA2(advanced DMA2) with two destinations.

The detail flow:

1. Software need to configure init_active bit (system control register bit 27) to make sure 74 card clocks are finished.
2. Software need to configure MMCBOOT[BOOTEN] to 1; and MMCBOOT[BOOTMODE] to 0 (normal fast boot), to 1(alternative boot); and MMCBOOT[BOOTACK] to select the ack mode or not. In DMA mode, configure MMCBOOT[AUTOSABGEN] to 1 for enable automatically stop at block gap feature. Also configure MMCBOOT[BOOTBLKCNT] to set the VAULE1(value of block count that need to trans first time), that host will stop at block gap when card block counter is equal to this value. And need to configure MMCBOOT[DTOCVACK] to select the ack timeout value according to the sd clk frequency.

3. Software then need to configure BLKATTR register to set block size/no. In DMA mode, it is better to set block number to the max value(16'hffff).
4. Software need to configure PROCTL[DTW].
5. Software enable ADMA2 by configuring PROCTL[DMAS].
6. Software need to set at least three pairs ADMA2 descriptor in boot memory (ie, in IRAM, at least 6 words). The first pair descriptor define the start address (ie, IRAM) and data length(ie,512byte*VALUE1) of first part boot code. Software also need to set the second pair descriptor, the second start address (any value that is writable), data length is suggest to set 1~2word (record as VAULE2). Note: the second couple desc also transfer useful data even at lease 1 word. Because our ADMA2 can't support 0 data_length data transfer descriptor.
7. Software need to configure CMDARG register to set argument to 0xFFFFFFFFFA in alternative fast boot, and don't need set in normal fast boot.
8. Software need to configure XFERTYP register to start the boot process . XFERTYP[CMDINX], XFERTYP[CMDTYP], XFERTYP[RSPTYP], XFERTYP[CICEN], XFERTYP[CCCEN], XFERTYP[AC12EN], XFERTYP[BCEN] and XFERTYP[DMAEN] are kept default value. XFERTYP[DPSEL] bit is set to 1, XFERTYP[DTDSEL] is set to 1, XFERTYP[MSBSEL] is set to 1. XFERTYP[DMAEN] is configured as 1 in DMA mode. And if XFERTYP[BCEN] is configured as 1, better to configure blk no in BLKATTR register to the max value.
9. When the step 8 is configured, boot process will begin, the first VAULE1 block number data has transfer. Software need to polling IRQSTAT[TC] bit to determine first transfer is end. Also software need to polling IRQSTAT[BGE] bit to determine if first transfer stop at block gap.
10. When IRQSTAT[TC] and IRQSTAT[BGE] bits are 1, . SW can analyzes the first code of VAULE1 block, initializes the new memory device, if required, and sets the third pair of descriptors to define the start address and length of the remaining part of boot code (VAULE3 the remain boot code block). Remember set the last descriptor with END.
11. Software need to configure MMCBOOT register (offset 0xc4) again. Set MMCBOOT[BOOTEN] bit to 1; and MMCBOOT[BOOTMODE] bit to 0 (normal fast boot), to 1(alternative boot); and MMCBOOT[BOOTACK] bit to select the ack mode or not. In DMA mode, configure MMCBOOT[AUTOSABGEN] bit to 1 for enable automatically stop at block gap feature. Also configure MMCBOOT[BOOTBLKCNT] bit to set the (VAULE1+1+VAULE3), that host will

stop at block gap when card block counter is equal to this value. And need to configure MMCBOOT[DTOCVACK] bit to select the ack timeout value according to the sd clk frequency.

12. Software need to clear IRQSTAT[TC] and IRQSTAT[BGE] bit. And software need to clear PROCTL[SABGREQ], and set PROCTL[CREQ] to 1 to resume the data transfer. Host will transfer the VALUE2 and VAULE3 data to the destination that is set by descriptor.
13. Software need to polling IRQSTAT[BGE] bit to determine if the fast boot is over.

Note

1. When ADMA boot flow is started, for SDHC, it is like a normal ADMA read operation. So setting ADMA2 descriptor as the normal ADMA2 transfer.
2. Need a few words length memory to keep descriptor.
3. For the 1~2 words data in second descriptor setting, it is the useful data, so software need to deal the data due to the application case.

48.6.7 Commands for MMC/SD/SDIO/CE-ATA

The following table lists the commands for the MMC/SD/SDIO/CE-ATA cards.

Refer to the corresponding specifications for more details about the command information.

There are four kinds of commands defined to control the Multimediacard:

1. broadcast commands (bc), no response.
2. broadcast commands with response (bcr), response from all cards simultaneously.
3. addressed (point-to-point) commands (ac), no data transfer on the DAT.
4. addressed (point-to-point) data transfer commands (adtc).

Table 48-37. Commands for MMC/SD/SDIO/CE-ATA cards

CMD INDEX	Type	Argument	Resp	Abbreviation	Description
CMD0	bc	[31:0] stuff bits	-	GO_IDLE_STATE	Resets all MMC and SD memory cards to idle state.

Table continues on the next page...

Table 48-37. Commands for MMC/SD/SDIO/CE-ATA cards (continued)

CMD INDEX	Type	Argument	Resp	Abbreviation	Description
CMD1	bcr	[31:0] OCR without busy	R3	SEND_OP_COND	Asks all MMC and SD memory cards in idle state to send their operation conditions register contents in the response on the CMD line.
CMD2	bcr	[31:0] stuff bits	R2	ALL_SEND_CID	Asks all cards to send their CID numbers on the CMD line.
CMD3 ¹	ac	[31:6] RCA [15:0] stuff bits	R1 R6 (SDIO)	SET/ SEND_RELATIVE_AD DR	Assigns relative address to the card.
CMD4	bc	[31:0] DSR [15:0] stuff bits	-	SET_DSR	Programs the DSR of all cards.
CMD5	bc	[31:0] OCR without busy	R4	IO_SEND_OP_COND	Asks all SDIO cards in idle state to send their operation conditions register contents in the response on the CMD line.
CMD6 ²	adtc	[31] Mode 0: Check function 1: Switch function [30:8] Reserved for function groups 6 ~ 3 (All 0 or 0xFFFF) [7:4] Function group1 for command system [3:0] Function group2 for access mode	R1	SWITCH_FUNC	Checks switch ability (mode 0) and switch card function (mode 1). Refer to "SD Physical Specification V1.1" for more details.
CMD6 ³	ac	[31:26] Set to 0 [25:24] Access [23:16] Index [15:8] Value [7:3] Set to 0 [2:0] Cmd Set	R1b	SWITCH	Switches the mode of operation of the selected card or modifies the EXT_CSD registers. Refer to "The MultiMediaCard System Specification Version 4.0 Final draft 2" for more details.
CMD7	ac	[31:6] RCA [15:0] stuff bits	R1b	SELECT/ DESELECT_CARD	Toggles a card between the stand-by and transfer states or between the programming and disconnect states. In both cases, the card is selected by its own relative address and gets deselected by any other address. Address 0 deselects all.

Table continues on the next page...

Table 48-37. Commands for MMC/SD/SDIO/CE-ATA cards (continued)

CMD INDEX	Type	Argument	Resp	Abbreviation	Description
CMD8	adtc	[31:0] stuff bits	R1	SEND_EXT_CSD	The card sends its EXT_CSD register as a block of data, with a block size of 512 bytes.
CMD9	ac	[31:6] RCA [15:0] stuff bits	R2	SEND_CSD	Addressed card sends its card-specific data (CSD) on the CMD line.
CMD10	ac	[31:6] RCA [15:0] stuff bits	R2	SEND_CID	Addressed card sends its card-identification (CID) on the CMD line.
CMD11	adtc	[31:0] data address	R1	READ_DAT_UNTIL_S TOP	Reads data stream from the card, starting at the given address, until a STOP_TRANSMISSION follows.
CMD12	ac	[31:0] stuff bits	R1b	STOP_TRANSMISSIO N	Forces the card to stop transmission.
CMD13	ac	[31:6] RCA [15:0] stuff bits	R1	SEND_STATUS	Addressed card sends its status register.
CMD14	Reserved				
CMD15	ac	[31:6] RCA [15:0] stuff bits	-	GO_INACTIVE_STAT E	Sets the card to inactive state in order to protect the card stack against communication breakdowns.
CMD16	ac	[31:0] block length	R1	SET_BLOCKLEN	Sets the block length (in bytes) for all following block commands (read and write). Default block length is specified in the CSD.
CMD17	adtc	[31:0] data address	R1	READ_SINGLE_BLOC K	Reads a block of the size selected by the SET_BLOCKLEN command.
CMD18	adtc	[31:0] data address	R1	READ_MULTIPLE_BL OCK	Continuously transfers data blocks from card to host until interrupted by a stop command.
CMD19	Reserved				
CMD20	adtc	[31:0] data address	R1	WRITE_DAT_UNTIL_S TOP	Writes data stream from the host, starting at the given address, until a STOP_TRANSMISSION follows.
CMD21-23	Reserved				
CMD24	adtc	[31:0] data address	R1	WRITE_BLOCK	Writes a block of the size selected by the SET_BLOCKLEN command.

Table continues on the next page...

Table 48-37. Commands for MMC/SD/SDIO/CE-ATA cards (continued)

CMD INDEX	Type	Argument	Resp	Abbreviation	Description
CMD25	adtc	[31:0] data address	R1	WRITE_MULTIPLE_BLOCK	Continuously writes blocks of data until a STOP_TRANSMISSION follows.
CMD26	adtc	[31:0] stuff bits	R1	PROGRAM_CID	Programming of the card identification register. This command shall be issued only once per card. The card contains hardware to prevent this operation after the first programming. Normally this command is reserved for the manufacturer.
CMD27	adtc	[31:0] stuff bits	R1	PROGRAM_CSD	Programming of the programmable bits of the CSD.
CMD28	ac	[31:0] data address	R1b	SET_WRITE_PROT	If the card has write protection features, this command sets the write protection bit of the addressed group. The properties of write protection are coded in the card specific data (WP_GRP_SIZE).
CMD29	ac	[31:0] data address	R1b	CLR_WRITE_PROT	If the card provides write protection features, this command clears the write protection bit of the addressed group.
CMD30	adtc	[31:0] write protect data address	R1	SEND_WRITE_PROT	If the card provides write protection features, this command asks the card to send the status of the write protection bits.
CMD31	Reserved				
CMD32	ac	[31:0] data address	R1	TAG_SECTOR_START	Sets the address of the first sector of the erase group.
CMD33	ac	[31:0] data address	R1	TAG_SECTOR_END	Sets the address of the last sector in a continuous range within the selection of a single sector to be selected for erase.
CMD34	ac	[31:0] data address	R1	UNTAG_SECTOR	Removes one previously selected sector from the erase selection.
CMD35	ac	[31:0] data address	R1	TAG_ERASE_GROUP_START	Sets the address of the first erase group within a range to be selected for erase.

Table continues on the next page...

Table 48-37. Commands for MMC/SD/SDIO/CE-ATA cards (continued)

CMD INDEX	Type	Argument	Resp	Abbreviation	Description
CMD36	ac	[31:0] data address	R1	TAG_ERASE_GROUP_END	Sets the address of the last erase group within a continuous range to be selected for erase.
CMD37	ac	[31:0] data address	R1	UNTAG_ERASE_GROUP	Removes one previously selected erase group from the erase selection.
CMD38	ac	[31:0] stuff bits	R1b	ERASE	Erase all previously selected sectors.
CMD39	ac	[31:0] RCA [15] register write flag [14:8] register address [7:0] register data	R4	FAST_IO	Used to write and read 8-bit (register) data fields. The command addresses a card, and a register, and provides the data for writing if the write flag is set. The R4 response contains data read from the address register. This command accesses application dependent registers which are not defined in the MMC standard.
CMD40	bcr	[31:0] stuff bits	R5	GO_IRQ_STATE	Sets the system into interrupt mode.
CMD41	Reserved				
CDM42	adtc	[31:0] stuff bits	R1b	LOCK_UNLOCK	Used to set/reset the password or lock/unlock the card. The size of the data block is set by the SET_BLOCK_LEN command.
CMD43~51	Reserved				
CMD52	ac	[31:0] stuff bits	R5	IO_RW_DIRECT	Access a single register within the total 128k of register space in any I/O function.
CMD53	ac	[31:0] stuff bits	R5	IO_RW_EXTENDED	Accesses a multiple I/O register with a single command. Allows the reading or writing of a large number of I/O registers.
CMD54	Reserved				
CMD55	ac	[31:16] RCA [15:0] stuff bits	R1	APP_CMD	Indicates to the card that the next command is an application specific command rather than a standard command.

Table continues on the next page...

Table 48-37. Commands for MMC/SD/SDIO/CE-ATA cards (continued)

CMD INDEX	Type	Argument	Resp	Abbreviation	Description
CMD56	adtc	[31:1] stuff bits [0]: RD/WR	R1b	GEN_CMD	Used either to transfer a data block to the card or to get a data block from the card for general purpose / application specific commands. The size of the data block is set by the SET_BLOCK_LEN command.
CMD57~59	Reserved				
CMD60	adtc	[31] WR [30:24] stuff bits [23:16] address [15:8] stuff bits [7:0] byte count	R1b	RW_MULTIPLE_REGISTER	CE-ATA devices contain a set of Status and Control registers that begin at register offset 80h. These registers are used to control the behavior of the device and to retrieve status information regarding the operation of the device. All Status and Control registers are WORD (32-bit) in size and are WORD aligned. CMD60 shall be used to read and write these registers.
CMD61	adtc	[31] WR [30:16] stuff bits [15:0] data unit count	R1b	RW_MULTIPLE_BLOCK	The host issues a RW_MULTIPLE_BLOCK (CMD61) to begin the data transfer for the ATA command.
CMD62~63	Reserved				
ACMD6 ⁴	ac	[31:2] stuff bits [1:0] bus width	R1	SET_BUS_WIDTH	Defines the data bus width ('00'=1bit or '10'=4bit bus) to be used for data transfer. The allowed data bus widths are given in SCR register.
ACMD13 ⁵	adtc	[31:0] stuff bits	R1	SD_STATUS	Send the SD memory card status.
ACMD22 ⁶	adtc	[31:0] stuff bits	R1	SEND_NUM_WR_SECTORS	Send the number of the written sectors (without errors). Responds with 32-bit plus the CRC data block.
ACMD23 ⁷	ac		R1	SET_WR_BLK_ERASE_COUNT	-
ACMD41 ⁸	bcr	[31:0] OCR	R3	SD_APP_OP_COND	Asks the accessed card to send its operating condition register (OCR) contents in the response on the CMD line.
ACMD42 ⁹	ac		R1	SET_CLR_CARD_DETECT	-

Table continues on the next page...

Table 48-37. Commands for MMC/SD/SDIO/CE-ATA cards (continued)

CMD INDEX	Type	Argument	Resp	Abbreviation	Description
ACMD51 ¹⁰	adtc	[31:0] stuff bits	R1	SEND_SCR	Reads the SD Configuration Register (SCR).

1. CMD3 differs for MMC and SD cards. For MMC cards, it is referred to as SET_RELATIVE_ADDR, with a response type of R1. For SD cards, it is referred to as SEND_RELATIVE_ADDR, with a response type of R6 (with RCA inside).
2. CMD6 differs completely between high speed MMC cards and high speed SD cards. Command SWITCH_FUNC is for high speed SD cards.
3. Command SWITCH is for high speed MMC cards as well as for CE-ATA cards over the MMC interface. The Index field can contain any value from 0-255, but only values 0-191 are valid. If the Index value is in the 192-255 range the card does not perform any modification and the SWITCH_ERROR status bit in the EXT_CSD register is set. The Access Bits are shown in [Table 48-38](#).
4. ACMDs shall be preceded with the APP_CMD command. (Commands listed are used for SD only, other SD commands not listed are not supported on this module).
5. ACMDs shall be preceded with the APP_CMD command. (Commands listed are used for SD only, other SD commands not listed are not supported on this module).
6. ACMDs shall be preceded with the APP_CMD command. (Commands listed are used for SD only, other SD commands not listed are not supported on this module).
7. ACMDs shall be preceded with the APP_CMD command. (Commands listed are used for SD only, other SD commands not listed are not supported on this module).
8. ACMDs shall be preceded with the APP_CMD command. (Commands listed are used for SD only, other SD commands not listed are not supported on this module).
9. ACMDs shall be preceded with the APP_CMD command. (Commands listed are used for SD only, other SD commands not listed are not supported on this module).
10. ACMDs shall be preceded with the APP_CMD command. (Commands listed are used for SD only, other SD commands not listed are not supported on this module).

The Access Bits for the EXT_CSD Access Modes are shown in the following table.

Table 48-38. EXT_CSD Access Modes

Bits	Access Name	Operation
00	Command Set	The command set is changed according to the Cmd Set field of the argument
01	Set Bits	The bits in the pointed byte are set, according to the 1 bits in the Value field.
10	Clear Bits	The bits in the pointed byte are cleared, according to the 1 bits in the Value field.
11	Write Byte	The Value field is written into the pointed byte.

48.7 Software restrictions

Software for the SDHC must observe the following restrictions.

48.7.1 Initialization active

The driver cannot set SYSCTL[INITA] bit when any of the command line or data lines is active, so the driver must ensure both PRSSTAT[CDIHB] and PRSSTAT[CIHB] bits are cleared. And in order to auto clear the SYSCTL[INITA] bit, the SYSCTL[SDCLKEN] bit must be '1', otherwise no clocks can go out to the card and SYSCTL[INITA] will never clear.

48.7.2 Software polling procedure

For polling read or write, once the software begins a buffer read or write, it must access exactly the number of times as the values set in the watermark level register; moreover, if the block size is not the times of the value in watermark level register (read and write respectively), the software must access exactly the remained number of words at the end of each block. For example, for read operation, if the WML[RDWML] is 4, indicating the watermark level is 16 bytes, block size is 40 bytes, and the block number is 2, then the access times for the burst sequence in the whole transfer process must be 4, 4, 2, 4, 4, 2.

48.7.3 Suspend operation

In order to suspend the data transfer, the software must inform SDHC that the suspend command is successfully accepted. To achieve this, after the Suspend command is accepted by the SDIO card, software must send another normal command marked as suspend command (XFERTYP[CMDTYP] bits set as '01') to inform SDHC that the transfer is suspended.

If software needs resume the suspended transfer, it should read the value in BLKATTR[BLKCNT] to save the remained number of blocks before sending the normal command marked as suspend, otherwise on sending such 'suspend' command, SDHC will regard the current transfer is aborted and change BLKATTR[BLKCNT] to its original value, instead of keeping the remained number of blocks.

48.7.4 Data length setting

For either ADMA (ADMA1 or ADMA2) transfer, the data in the data buffer must be word aligned, so the data length set in the descriptor must be times of 4.

48.7.5 (A)DMA address setting

To configure ADMA1/ADMA2/DMA address register, when TC[IRQSTAT] bit is set, the register will always update itself with the internal address value to support dynamic address synchronization, so software must make sure TC[IRQSTAT] bit is cleared prior to configuring ADMA1/ADMA2/DMA address register.

48.7.6 Data port access

Data port does not support parallel access. For example, during an external DMA access, it is not allowed to write any data to the data port by CPU; or during a CPU read operation, it is also prohibited to write any data to the data port, by either CPU or external DMA. Otherwise the data would be corrupted inside the SDHC buffer.

48.7.7 Change clock frequency

SDHC does not automatically gates off the card clock when the host driver changes the clock frequency. To remove possible glitch on the card clock, clear SYSCTL[SDCLKEN] bit when changing clock divisor value and set SYSCTL[SDCLKEN] bit to '1' after PRSSTAT[SDSTB] bit is '1' again.

48.7.8 Multi-block read

For pre-defined multi-block read operation, i.e., the number of blocks to read has been defined by previous CMD23 for MMC, or pre-defined number of blocks in CMD53 for SDIO/SDCombo, or whatever multi-block read without abort command at card side, an abort command, either automatic or manual CMD12/CMD52, is still required by SDHC after the pre-defined number of blocks are done, to drive the internal start response timeout. It is recommended to manually send an abort command with XFERTYP[RSPTYP] both bits cleared.



Chapter 49

Integrated interchip sound (I2S)

49.1 Introduction

NOTE

For the chip-specific implementation details of this module's instances see the chip configuration chapter.

This section discusses the architecture, the programming model, the operating modes, and initialization of integrated interchip sound (I²S) module.

The I²S is a full-duplex, serial port that allows the chip to communicate with a variety of serial devices. Such serial devices are:

- Standard codecs
- Digital signal processors (DSPs)
- Microprocessors
- Peripherals
- Audio codecs that implement the inter-IC sound bus (I²S) and the Intel[®] AC97 standards

The I²S module typically transfers samples in a periodic manner. The I²S consists of independent transmitter and receiver sections with independent clock generation and frame synchronization.

49.1.1 Block diagram

The following figure illustrates the organization of the I²S. It consists of control registers to set up the port, status register, separate transmit and receive circuits with FIFO registers, and separate serial clock and frame sync generation for the transmit and receive sections. The second set of Tx and Rx FIFOs replicates the logic used for the first set of FIFOs.

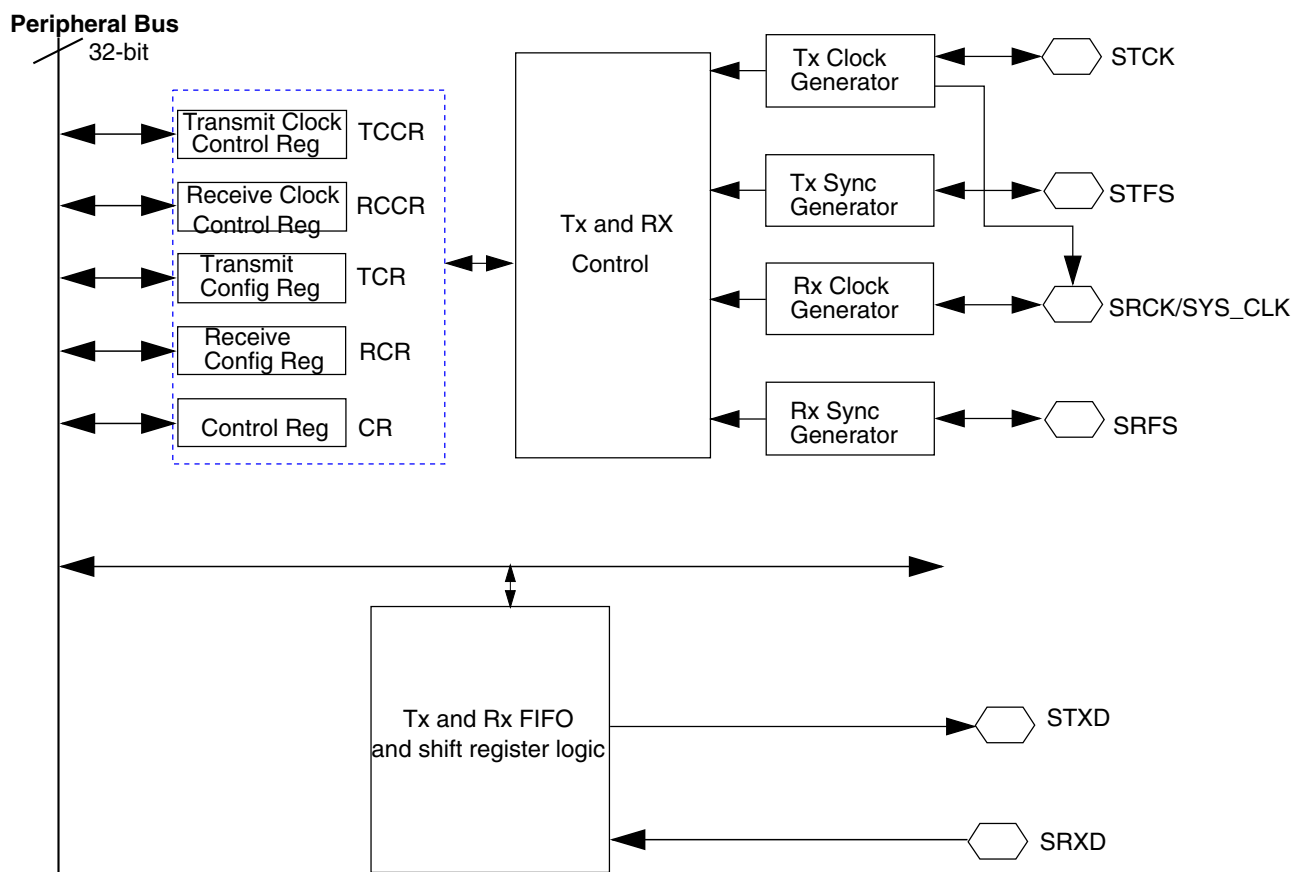

Figure 49-1. Customer-facing I²S block diagram

49.1.2 Features

The I²S includes the following features:

- Independent (asynchronous) or shared (synchronous) transmit and receive sections with separate or shared internal/external clocks and frame syncs, operating in master or slave mode.
- Normal mode operation using frame sync

- Network mode operation allowing multiple devices to share the port with as many as thirty-two time slots
- Gated clock mode operation requiring no frame sync
- 2 sets of transmit and receive FIFOs. Each of the four FIFOs is 15x32 bits. The two sets of Tx/Rx FIFOs can be used in network mode to provide 2 independent channels for transmission and reception
- Programmable data interface modes such as I²S, lsb- and msb-aligned
- Programmable word length (8, 10, 12, 16, 18, 20, 22 or 24 bits)
- Program options for frame sync and clock generation
- Programmable I²S modes (master, slave or normal). Oversampling clock available as output from SRCK in I²S master mode
- AC97 support
- Completely separate clock and frame sync selections for the receive and transmit sections. In the AC97 standard, the clock is taken from an external source and frame sync is generated internally.
- External network clock input for I²S master mode. Programmable oversampling clock of the sampling frequency available as output in master mode at SRCK, when operated in synchronous mode.
- Programmable internal clock divider
- Transmit and receive time slot mask registers for reduced CPU overhead
- I²S power-down feature

49.1.3 Modes of operation

I²S has the following basic operating modes.

- [Normal mode](#)
 - Asynchronous protocol
 - Synchronous protocol
- [Network mode](#)

- Asynchronous protocol
- Synchronous protocol
- Gated clock mode
 - Synchronous protocol only
- I²S mode
- AC97 mode
 - AC97 fixed mode (ACNT[FV] = 0)
 - AC97 variable mode (ACNT[FV] = 1)

These modes can be programmed by several bits in the I²S control registers. The following table lists these operating modes and some of the typical applications in which they can be used:

Table 49-1. I²S Operating Modes

TX, RX Sections	Serial clock	Mode	Typical application
Asynchronous	Continuous	Normal	Multiple synchronous CODECs
Asynchronous	Continuous	Network	TDM codec or DSP networks
Synchronous	Continuous	Normal	Multiple synchronous codecs
Synchronous	Continuous	Network	TDM codec or DSP network
Synchronous	Gated	Normal	SPI-type devices: DSP to MCU

The transmit and receive sections of the I²S can be synchronous or asynchronous. In synchronous mode, the transmitter and the receiver use a common clock and frame synchronization signal. Masking of slots for transmit and receive section can differ in synchronous mode. Also the RCR[RXBIT0, RSHFD] bits can continue affecting shifting-in of received data in synchronous mode. In asynchronous mode, the transmitter and receiver each has its own clock and frame synchronization signals. Continuous or gated clock mode can be selected. In continuous mode, the clock runs continuously. In gated clock mode, the clock is only functioning during transmission.

Normal or network mode can also be selected. In normal mode, the I²S functions with one data word of I/O per frame. In network mode, any number from two to thirty-two data words of I/O per frame can be used. Network mode is typically used in star time-division-multiplex networks with other processors or codecs, allowing interface to time division multiplexed networks without additional logic. Use of gated clock mode is not allowed in network mode. These distinctions result in the basic operating modes that allow the I²S to communicate with a wide variety of devices.

The I²S supports both normal and network modes, and these can be selected independently of whether the transmitter and receiver are synchronous or asynchronous. Typically, these protocols are used in a periodic manner, where data transfers at regular intervals, such as at the sampling rate of an external codec. Both modes use the concept of a frame. The beginning of the frame is marked with a frame sync when programmed with continuous clock. The RCCR[DC] or TCCR[DC] bits determine the length of the frame, depending on whether data is being transmitted or received.

The number of words transferred per frame depends on the mode of the I²S. In normal mode, one data word is transferred per frame. In network mode, the frame divides into two to 32 time slots. In each time slot, one data word is optionally transferred.

Apart from the above basic modes of operation, I²S supports the following modes which require some specific programming.

- I²S mode
- AC97 mode
 - AC97 fixed mode
 - AC97 variable mode

In non-I²S slave modes (external frame sync), the I²S's programmed word length setting should be equal to the word length setting of the master. In I²S slave mode, the I²S's programmed word length setting can be lesser than or equal to the word length setting of the I²S master (external codec).

In slave modes, the I²S's programmed frame length setting (TCCR[DC] or RCCR[DC] bits) can be lesser than or equal to the frame length setting of the master (external codec).

See [Detailed operating mode descriptions](#) for more details on the above modes.

49.2 I²S signal descriptions

Table 49-2. I²S signal descriptions

Signal	Description	I/O
SRCK	Serial receive clock. SRCK can be used as an input or output. <ul style="list-style-type: none"> • In asynchronous mode the receiver uses this clock signal and it is always continuous. • In synchronous mode, the STCK port is used instead for clocking in data. 	I/O

Table continues on the next page...

Table 49-2. I²S signal descriptions (continued)

Signal	Description	I/O
SRFS	Serial receive frame Sync. The SRFS port can be used as an input or output. The frame sync is used by the receiver to synchronize the transfer of data. The frame sync signal can be one bit or one word in length and can occur one bit before the transfer of data or right at the transfer of data. If SRFS is configured as an input, the external device should drive SRFS during the rising edge of STCK or SRCK.	I/O
SRXD	Serial receive data. The SRXD port is an input and is used to bring serial data into the receive data shift register.	I
STCK	Serial transmit clock. The STCK port can be used as an input or output. This clock signal is used by the transmitter and can be continuous or gated. During gated clock mode, data on STCK is valid only during the transmission of data. Otherwise, it is pulled to the inactive state. In synchronous mode, this port is used by the transmit and receive sections.	I/O
STFS	Serial transmit frame sync. The STFS port can be used as an input or output. The frame sync is used by the transmitter to synchronize the transfer of data. The frame sync signal can be one bit or one word in length and can occur one bit before the transfer of data or right at the transfer of data. In synchronous mode, this port is used by both the transmit and receive sections. In gated clock mode, frame sync signals are not used. If STFS is configured as an input, the external device should drive STFS during the rising edge of STCK if TSCKP is positive-edge triggered. The external device should drive STFS during the falling edge of STCK if TSCKP is negative-edge triggered.	I/O
STXD	Serial transmit data. The STXD port is an output and transmits data from the serial transmit shift register. The STXD port is an output port when data is being transmitted and is disabled between data word transmissions and on the trailing edge of the bit clock after the last bit of a word is transmitted.	O

The following figure shows the main I²S configurations. These ports support all transmit and receive functions with continuous or gated clock as shown.

Note

Gated clock implementations do not require the use of the frame sync ports (STFS and SRFS).

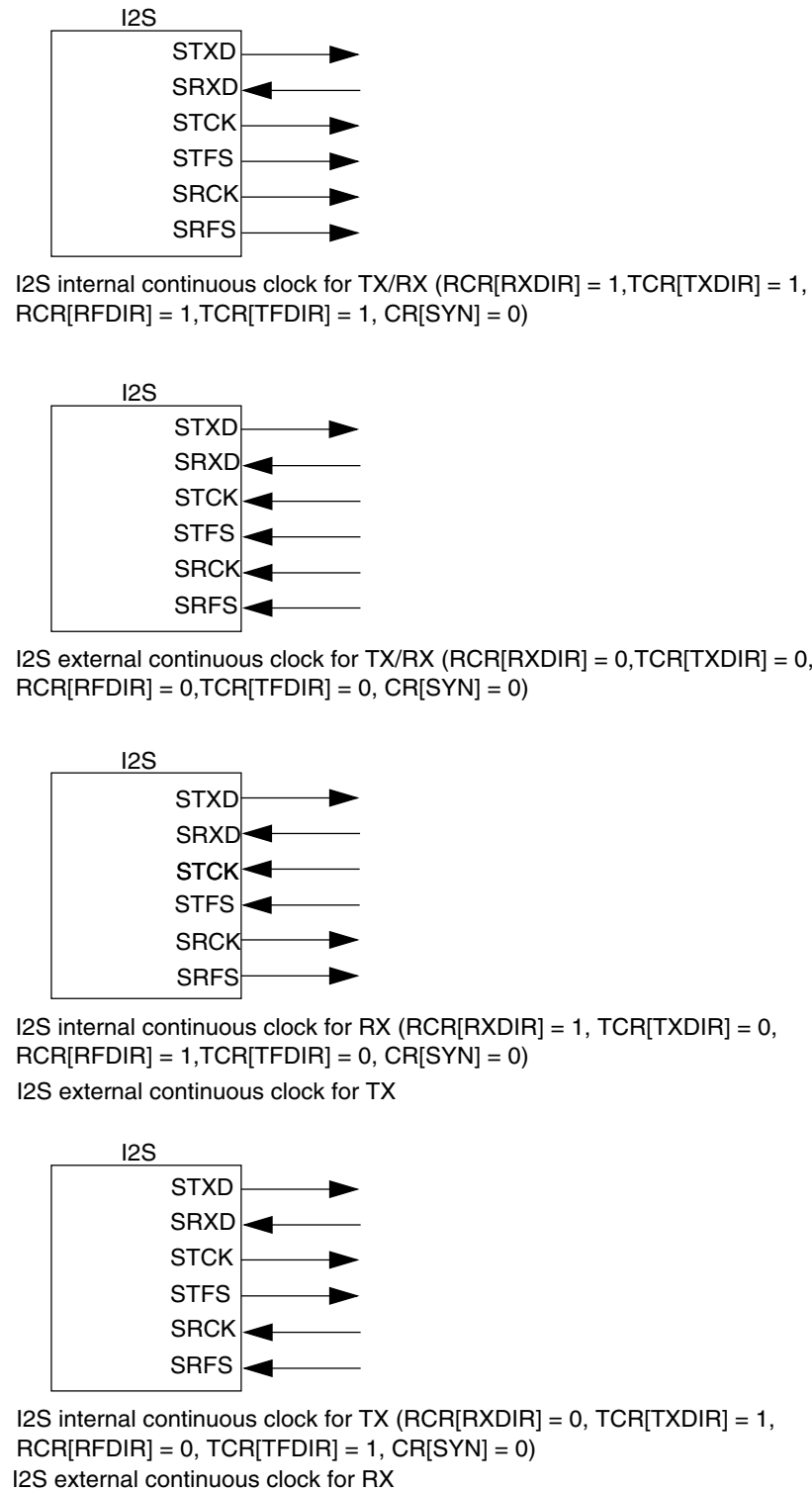

Figure 49-2. Asynchronous (SYN = 0) I²S configurations—continuous clock

The following figure shows an example of the port signals for an 8-bit data transfer. Continuous and gated clock signals are shown, as well as the bit-length frame sync signal and the word-length frame sync signal.

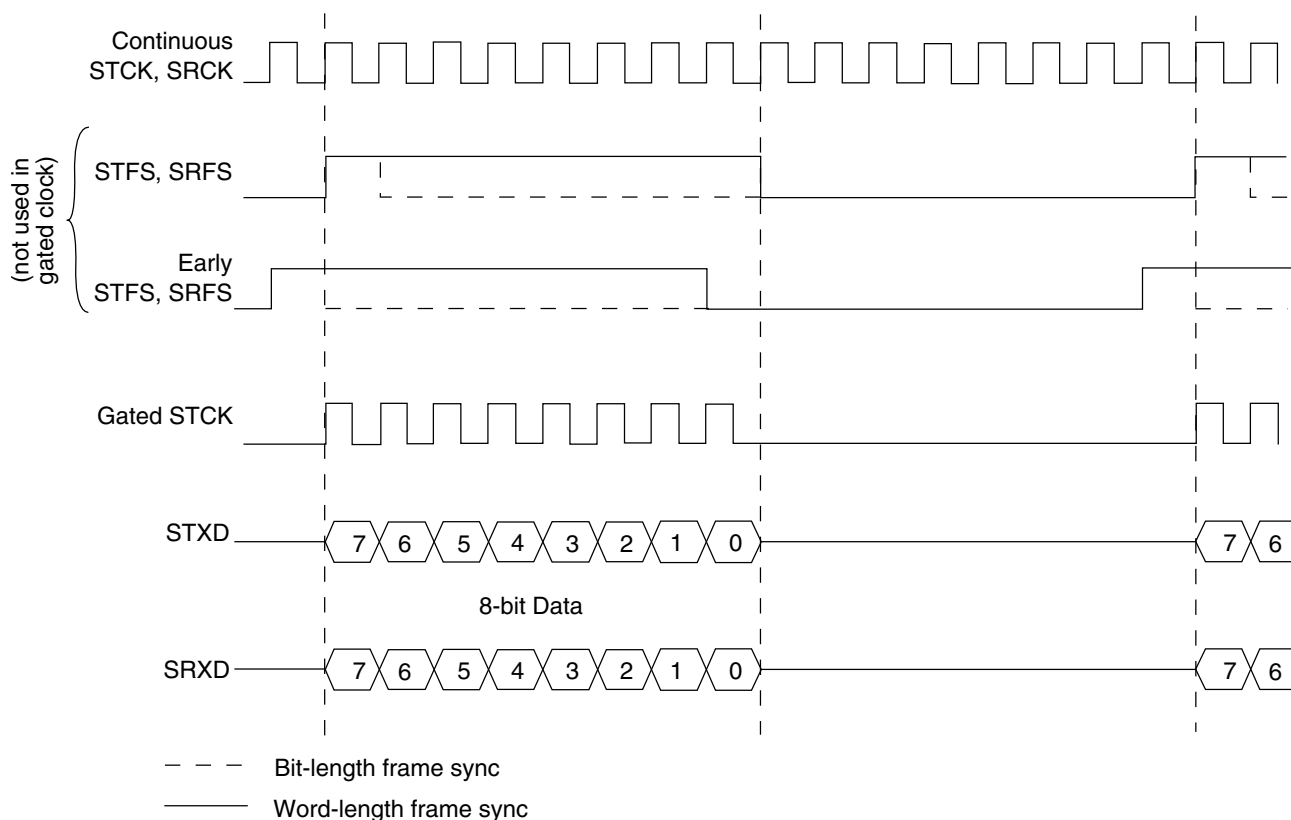

Figure 49-3. Serial clock and frame sync timing

The following table shows a list of clock pin configurations.

Table 49-3. Clock pin configurations

CR [SYN]	RCR		TCR		SRCK	STCK	SRFS	STFS
	RXDIR	RFDIR	TXDIR	TFDIR				
Asynchronous Mode								
0	0	0	0	0	RCK in	TCK in	RFS in	TFS in
0	0	0	0	1	RCK in	TCK in	RFS in	TFS out
0	0	1	0	0	RCK in	TCK in	RFS out	TFS in
0	0	1	0	1	RCK in	TCK in	RFS out	TFS out
0	0	0	1	0	RCK in	TCK out	RFS in	TFS in
0	0	0	1	1	RCK in	TCK out	RFS in	TFS out
0	0	1	1	0	RCK in	TCK out	RFS out	TFS in
0	0	1	1	1	RCK in	TCK out	RFS out	TFS out
0	1	0	0	0	RCK out	TCK in	RFS in	TFS in
0	1	0	0	1	RCK out	TCK in	RFS in	TFS out
0	1	1	0	0	RCK out	TCK in	RFS out	TFS in
0	1	1	0	1	RCK out	TCK in	RFS out	TFS out

Table continues on the next page...

Table 49-3. Clock pin configurations (continued)

CR [SYN]	RCR		TCR			SRCK	STCK	SRFS	STFS
	RXDIR	RFDIR	TXDIR	TFDIR					
0	1	0	1	0		RCK out	TCK out	RFS in	TFS in
0	1	0	1	1		RCK out	TCK out	RFS in	TFS out
0	1	1	1	0		RCK out	TCK out	RFS out	TFS in
0	1	1	1	1		RCK out	TCK out	RFS out	TFS out
Synchronous mode									
1	0	x	0	0		—	CK in	—	FS in
1	0	x	0	1		—	CK in	—	FS out
1	0	x	1	0		—	CK out	—	FS in
1	0	x	1	1		—	CK out	—	FS out
1	1	x	0	x		—	Gated in	—	—
1	1	x	1	x		—	Gated out	—	—

49.3 Memory map/register definition

This section consists of register descriptions in address order. Each description includes a standard register diagram with an associated figure number. Details of register bit and field function follow the register diagrams in bit order.

I2S memory map

Absolute address (hex)	Register name	Width (in bits)	Access	Reset value	Section/page
4002_F000	I2S Transmit Data Registers 0 (I2S0_TX0)	32	R/W	0000_0000h	49.3.1/1447
4002_F004	I2S Transmit Data Registers 1 (I2S0_TX1)	32	R/W	0000_0000h	49.3.2/1447
4002_F008	I2S Receive Data Registers 0 (I2S0_RX0)	32	R	0000_0000h	49.3.3/1448
4002_F00C	I2S Receive Data Registers 1 (I2S0_RX1)	32	R	0000_0000h	49.3.4/1448
4002_F010	I2S Control Register (I2S0_CR)	32	R/W	0000_0000h	49.3.5/1449
4002_F014	I2S Interrupt Status Register (I2S0_ISR)	32	R/W	0000_3003h	49.3.6/1452

Table continues on the next page...

I2S memory map (continued)

Absolute address (hex)	Register name	Width (in bits)	Access	Reset value	Section/page
4002_F018	I2S Interrupt Enable Register (I2S0_IER)	32	R/W	0000_3003h	49.3.7/1457
4002_F01C	I2S Transmit Configuration Register (I2S0_TCR)	32	R/W	0000_0200h	49.3.8/1461
4002_F020	I2S Receive Configuration Register (I2S0_RCR)	32	R/W	0000_0200h	49.3.9/1463
4002_F024	I2S Transmit Clock Control Registers (I2S0_TCCR)	32	R/W	0004_0000h	49.3.10/1465
4002_F028	I2S Receive Clock Control Registers (I2S0_RCCR)	32	R/W	0004_0000h	49.3.11/1467
4002_F02C	I2S FIFO Control/Status Register (I2S0_FCSR)	32	R/W	0081_0081h	49.3.12/1468
4002_F038	I2S AC97 Control Register (I2S0_ACNT)	32	R/W	0000_0000h	49.3.13/1474
4002_F03C	I2S AC97 Command Address Register (I2S0_ACADD)	32	R/W	0000_0000h	49.3.14/1475
4002_F040	I2S AC97 Command Data Register (I2S0_ACDAT)	32	R/W	0000_0000h	49.3.15/1476
4002_F044	I2S AC97 Tag Register (I2S0_ATAG)	32	R/W	0000_0000h	49.3.16/1476
4002_F048	I2S Transmit Time Slot Mask Register (I2S0_TMSK)	32	R/W	0000_0000h	49.3.17/1477
4002_F04C	I2S Receive Time Slot Mask Register (I2S0_RMSK)	32	R/W	0000_0000h	49.3.18/1477
4002_F050	I2S AC97 Channel Status Register (I2S0_ACCST)	32	R	0000_0000h	49.3.19/1478
4002_F054	I2S AC97 Channel Enable Register (I2S0_ACCEN)	32	W (always reads zero)	0000_0000h	49.3.20/1478
4002_F058	I2S AC97 Channel Disable Register (I2S0_ACCDIS)	32	W (always reads zero)	0000_0000h	49.3.21/1479

49.3.1 I²S Transmit Data Registers 0 (I2Sx_TX0)

The TX0 registers store the data to be transmitted by the I2S.

Addresses: I2S0_TX0 is 4002_F000h base + 0h offset = 4002_F000h

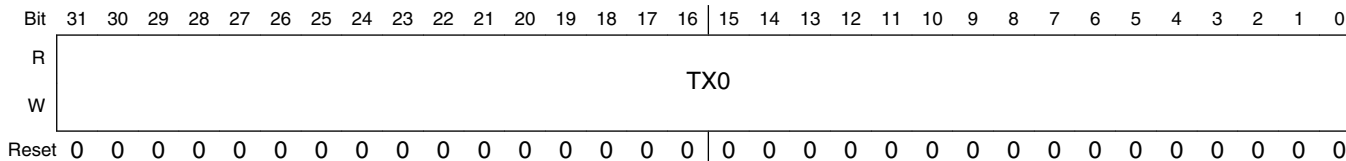

I2Sx_TX0 field descriptions

Field	Description
31–0 TX0	<p>I2S transmit data</p> <p>I²S transmit data. These bits store the data to be transmitted by the I²S. These are implemented as the first word of their respective Tx FIFOs. Data written to these registers transfers to the transmit shift register (TXSR), when shifting of the previous data is complete. If both FIFOs are in use, data alternately transfers from TX0 and TX1 to TXSR. TX1 can only be used in two-channel mode. Multiple writes to the TX registers do not result in the previous data being over-written by the subsequent data. Instead they are ignored. Protection from over-writing is present irrespective of whether the transmitter is enabled or not. Example: If Tx FIFO0 is in use and you write Data1 - 16 to TX0, Data16 does not overwrite Data1. Data1 - 15 are stored in the FIFO while Data16 is discarded. Example: If Tx FIFO0 is not in use and you write Data1, Data2 to TX0, then Data2 does not overwrite Data1 and is discarded.</p> <p>NOTE: Enable I²S (CR[I2SEN]=1) before writing to the I²S transmit data registers.</p>

49.3.2 I²S Transmit Data Registers 1 (I2Sx_TX1)

The TX1 registers store the data to be transmitted by the I2S.

Addresses: I2S0_TX1 is 4002_F000h base + 4h offset = 4002_F004h

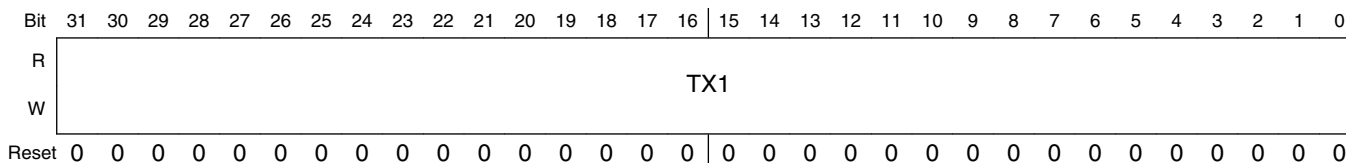

I2Sx_TX1 field descriptions

Field	Description
31–0 TX1	<p>I2S transmit data</p> <p>I²S transmit data. These bits store the data to be transmitted by the I²S. These are implemented as the first word of their respective Tx FIFOs. Data written to these registers transfers to the transmit shift register (TXSR), when shifting of the previous data is complete. If both FIFOs are in use, data alternately transfers from TX0 and TX1 to TXSR. TX1 can only be used in two-channel mode. Multiple writes to the TX registers do not result in the previous data being over-written by the subsequent data. Instead they are ignored. Protection from over-writing is present irrespective of whether the transmitter is enabled or not.</p>

I2Sx_TX1 field descriptions (continued)

Field	Description
	<p>Example: If Tx FIFO0 is in use and you write Data1 - 16 to TX0, Data16 does not overwrite Data1. Data1 - 15 are stored in the FIFO while Data16 is discarded. Example: If Tx FIFO0 is not in use and you write Data1, Data2 to TX0, then Data2 does not overwrite Data1 and is discarded.</p> <p>NOTE: Enable I²S (CR[I2SEN]=1) before writing to the I²S transmit data registers.</p>

49.3.3 I²S Receive Data Registers 0 (I2Sx_RX0)

The RX0 registers store the data received by the I2S.

Addresses: I2S0_RX0 is 4002_F000h base + 8h offset = 4002_F008h

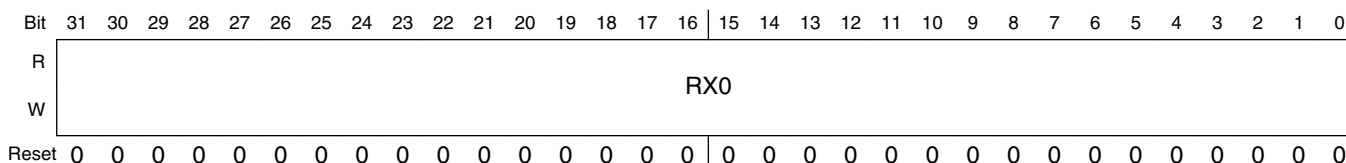

I2Sx_RX0 field descriptions

Field	Description
31–0 RX0	<p>I2S Receive Data</p> <p>These bits store the data received by the I²S. These are implemented as the first word of their respective Rx FIFOs. These bits receive data from the RXSR depending on the mode of operation. In case both FIFOs are in use, data is transferred to each data register alternately. RX1 can only be used in two-channel mode of operation.</p>

49.3.4 I²S Receive Data Registers 1 (I2Sx_RX1)

The RX1 registers store the data received by the I2S.

Addresses: I2S0_RX1 is 4002_F000h base + Ch offset = 4002_F00Ch

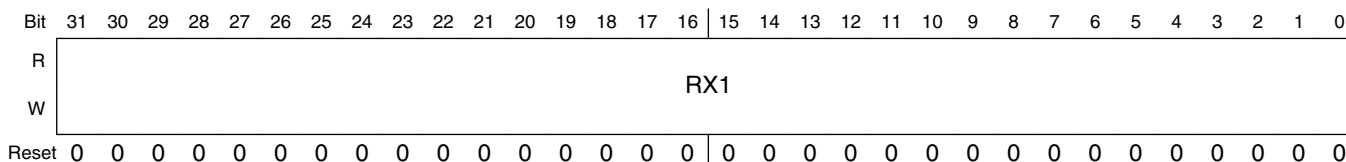

I2Sx_RX1 field descriptions

Field	Description
31–0 RX1	<p>I2S Receive Data</p> <p>These bits store the data received by the I²S. These are implemented as the first word of their respective Rx FIFOs. These bits receive data from the RXSR depending on the mode of operation. In case both</p>

I2Sx_RX1 field descriptions (continued)

Field	Description
	FIFOs are in use, data is transferred to each data register alternately. RX1 can only be used in two-channel mode of operation.

49.3.5 I²S Control Register (I2Sx_CR)

The I2S Control Register (CR) sets up the I2S. I2S reset is controlled by bit 0 in the CR. I2S operating modes are also selected in this register (except AC97 mode which is selected in the ACNT register).

Addresses: I2S0_CR is 4002_F000h base + 10h offset = 4002_F010h

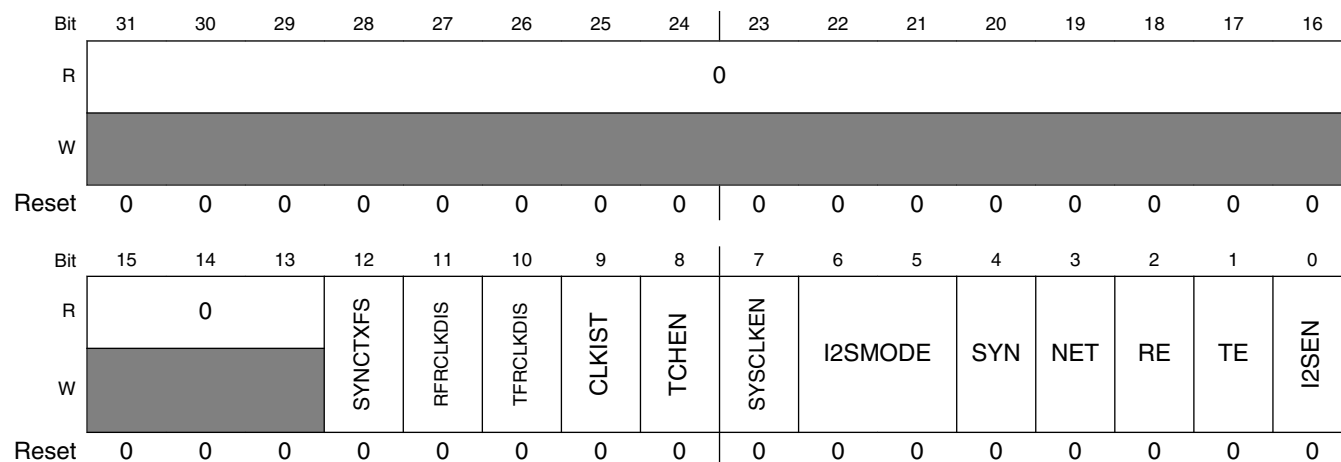

I2Sx_CR field descriptions

Field	Description
31–13 Reserved	This read-only field is reserved and always has the value zero.
12 SYNCTXFS	<p>SYNCTXFS bit provides a safe window for CR[TE] to be visible to the internal circuit which is just after FS occurrence. When SYNCTXFS is set, CR[TE] gets latched on FS occurrence and latched CR[TE] is used to enable/disable I²S transmitter. CR[TE] needs setup of 2 bit-clock cycles before occurrence of FS. If CR[TE] is changed within 2 bit-clock cycles of FS occurrence, there is high probability that CR[TE] will be latched on next FS.</p> <p>NOTE: With TFRCLKDIS feature on, CR[TE] is used directly to enable transmitter in following cases (i) Sync mode and Rx disabled (ii) Async Mode. Latched-TE is used to disable the transmitter.</p> <p>This bit has no relevance in gated mode and AC97 mode.</p> <p>0 CR[TE] not latched with FS occurrence and used directly for transmitter enable/disable. 1 CR[TE] latched with FS occurrence and latched-TE used for transmitter enable/disable.</p>
11 RFRCLKDIS	Receive Frame Clock Disable.

Table continues on the next page...

I2Sx_CR field descriptions (continued)

Field	Description
	<p>This bit provides the option to keep the frame-sync and clock enabled or to disable them after the receive frame in which the receiver is disabled. Writing to this bit has effect only when CR[RE] is disabled. The receiver is disabled by clearing the CR[RE] bit.</p> <p>0 Continue frame-sync/clock generation after current frame during which CR[RE] is cleared. This may be required when Frame-sync and Clocks are required from I²S, even when no data is to be received.</p> <p>1 Stop frame-sync/clock generation at next frame boundary. This will be effective also in case where receiver is already disabled in current or previous frames.</p>
10 TFRCLKDIS	<p>Transmit Frame Clock Disable.</p> <p>This bit provide option to keep the frame-sync and clock enabled or disabled after current transmit frame, in which transmitter is disabled by clearing CR[TE] bit. Writing to this bit has effect only when I²S is enabled CR[TE] is disabled.</p> <p>0 Continue frame-sync/clock generation after current frame during which CR[TE] is cleared. This may be required when frame-sync and clocks are required from I²S, even when no data is to be received.</p> <p>1 Stop frame-sync/clock generation at next frame boundary. This will be effective also in case where transmitter is already disabled in current or previous frames.</p>
9 CLKIST	<p>Clock Idle State.</p> <p>This bit controls the idle state of the transmit clock port during I²S internal gated mode. Note: When Clock idle state is `1' the clock polarity should always be negedge triggered and when clock idle = `0' the clock polarity should always be positive edge triggered.</p> <p>0 Clock idle state is `0'.</p> <p>1 Clock idle state is `1'.</p>
8 TCHEN	<p>Two-Channel Operation Enable.</p> <p>This bit allows I²S to operate in the two-channel mode. In this mode while receiving, the RXSR transfers data to RX0 and RX1 alternately and while transmitting, data is alternately transferred from TX0 and TX1 to TXSR. For an even number of slots, two-channel operation can be enabled to optimize usage of both FIFOs or disabled as in the case of odd number of active slots. This feature is especially useful in I2S mode, where data for left speaker can be placed in Tx-FIFO0 and for right speaker in Tx-FIFO1.</p> <p>0 Two-channel mode disabled.</p> <p>1 Two-channel mode enabled.</p>
7 SYSCLKEN	<p>System Clock (Oversampling Clock) Enable.</p> <p>When set, this bit allows the I²S to output the (network clock) at the SRCK port, provided that synchronous mode, and transmit internal clock mode are set. The relationship between bit clock and network clock is determined by DIV2, PSR, and PM bits. This feature is especially useful in I2S master mode to output oversampling clock on SRCK port.</p> <p>0 Network clock not output on SRCK port.</p> <p>1 Network clock output on SRCK port.</p>
6-5 I2SMODE	<p>I2S Mode Select</p> <p>These bits allow the I²S to operate in normal, I²S master or I²S slave mode.</p> <p>00 Normal mode</p> <p>01 I²S master mode</p>

Table continues on the next page...

I2Sx_CR field descriptions (continued)

Field	Description
	10 I ² S slave mode 11 Normal mode
4 SYN	Synchronous Mode. This bit controls whether I ² S is in synchronous mode or not. In synchronous mode, the transmit and receive sections of I ² S share a common clock port (STCK) and frame sync port (STFS). 0 Asynchronous mode selected. 1 Synchronous mode selected.
3 NET	Network Mode. This bit controls whether I ² S is in network mode or not. 0 Network mode not selected. 1 Network mode selected.
2 RE	Receive Enable. Enables the receive section of the I ² S. When this bit is enabled, data reception starts with the arrival of the next frame sync. If data is being received when this bit is cleared, data reception continues until the end of the current frame and then stops. If this bit is set again before the second to last bit of the last time slot in the current frame, then reception continues without interruption. CR[RE] should not be toggled in the same frame. 0 Receive section disabled. 1 Receive section enabled.
1 TE	Transmit Enable. This control bit enables the transmit section of the I ² S. It enables the transfer of the contents of the TX registers to the TXSR and also enables the internal transmit clock. The transmit section is enabled when this bit is set and a frame boundary is detected. When this bit is cleared, the transmitter continues to send data until the end of the current frame and then stops. Data can be written to the TX registers with the CR[TE] bit cleared (the corresponding TDE bit will be cleared). If the CR[TE] bit is cleared and then set again before the second to last bit of the last time slot in the current frame, data transmission continues without interruption. The normal transmit enable sequence is to write data to the TX register(s) and then set the CR[TE] bit. The normal disable sequence is to clear the CR[TE] and IER[TIE] bits after the TDE bit is set. In gated clock mode, clearing the CR[TE] bit results in the clock stopping after the data currently in TXSR has shifted out. When the CR[TE] bit is set, the clock starts immediately (for internal gated clock mode). CR[TE] should not be toggled in the same frame. After enabling/disabling transmission, I ² S expects 4 setup clock cycles before arrival of frame-sync for frame-sync to be accepted by I ² S. In case of fewer clock cycles, there is high probability of the frame-sync to get missed. NOTE: If continuous clock is not provided, I ² S expects 6 clock cycles before arrival of frame-sync for frame-sync to be accepted by I ² S. 0 Transmit section disabled. 1 Transmit section enabled.
0 I2SEN	I2S Enable.

Table continues on the next page...

I2Sx_CR field descriptions (continued)

Field	Description
	This bit is used to enable/disable the I ² S. When disabled, all I ² S status bits are preset to the same state produced by the power-on reset, all control bits are unaffected, the contents of Tx and Rx FIFOs are cleared. When I ² S is disabled, all internal clocks are disabled (except register access clock).
0	I ² S is disabled.
1	I ² S is enabled.

49.3.6 I²S Interrupt Status Register (I2Sx_ISR)

The I2S interrupt status register (ISR) is used to monitor the I2S. This register is used by the core to interrogate the status of the I2S. In gated mode of operation the TFS, RFS, TLS, RLS, TFRC and RFRC bits of AISR register are not generated. The status bits are described in the following table.

NOTE

- I²S status flags are valid when I²S is enabled.
- All the flags in the ISR are updated after the first bit of the next I²S word has completed transmission or reception. Certain status bits (ROE0/1 and TUE0/1) are cleared by writing 1 to the corresponding interrupt status bit in ISR.

Addresses: I2S0_ISR is 4002_F000h base + 14h offset = 4002_F014h

Bit	31	30	29	28	27	26	25	24	23	22	21	20	19	18	17	16
R	0							RFRC	TRFC	0				CMDAU	CMDDU	RXT
W	-							RFRC	TRFC	-				CMDAU	CMDDU	RXT
Reset	0	0	0	0	0	0	0	0	0	0	0	0	0	0	0	0
Bit	15	14	13	12	11	10	9	8	7	6	5	4	3	2	1	0
R	RDR1	RDR0	TDE1	TDE0	ROE1	ROE0	TUE1	TUE0	TFS	RFS	TLS	RLS	RFF1	RFF0	TFE1	TFE0
W	-	-	-	-	w1c	w1c	w1c	w1c	-	-	-	-	-	-	-	-
Reset	0	0	1	1	0	0	0	0	0	0	0	0	0	0	1	1

I2Sx_ISR field descriptions

Field	Description
31–25 Reserved	This read-only field is reserved and always has the value zero.
24 RFRC	<p>Receive Frame Complete.</p> <p>This flag is set at the end of the frame during which receiver is disabled. If receive frame and clock are not disabled in the same frame, this flag is also set at the end of the frame in which receive frame and clock are disabled. See description of CR[RFRCCLKDIS] bit for more details on how to disable receiver frame and clock or keep them enabled after receiver is disabled.</p> <p>0 End of frame not reached. 1 End of frame reached after disabling CR[RE] or disabling CR[RFRCCLKDIS], when receiver is already disabled.</p>
23 TRFC	<p>Transmit Frame Complete.</p> <p>This flag is set at the end of the frame during which transmitter is disabled. If transmit frame and clock are not disabled in the same frame, this flag is also set at the end of the frame in which transmit frame and clock are disabled. See description of CR[TRFCCLKDIS] bit for more details on how to disable transmit frame and clock or keep them enabled after transmitter is disabled.</p> <p>0 End of frame not reached. 1 End of frame reached after disabling CR[TE] or disabling CR[TRFCCLKDIS], when transmitter is already disabled.</p>
22–19 Reserved	This read-only field is reserved and always has the value zero.
18 CMDAU	<p>Command Address Register Updated.</p> <p>This bit causes the command address Updated interrupt (when IER[CMDAUIEN] bit is set). This status bit is set each time there is a difference in the previous and current value of the received command address. This bit is cleared on reading the ACADD register.</p> <p>0 No change in ACADD register. 1 ACADD register updated with different value.</p>
17 CMDDU	<p>Command Data Register Updated.</p> <p>This bit causes the command data updated interrupt (when IER[CMDDUIEN] bit is set). This status bit is set each time there is a difference in the previous and current value of the received command data. This bit is cleared on reading the ACDAT register.</p> <p>0 No change in ACDAT register. 1 ACDAT register updated with different value.</p>
16 RXT	<p>Receive Tag Updated.</p> <p>This status bit is set each time there is a difference in the previous and current value of the received tag. It causes the receive tag interrupt (if IER[RXTEN] bit is set). This bit is cleared on reading the ATAG register.</p> <p>0 No change in ATAG register. 1 ATAG register updated with different value.</p>
15 RDR1	Receive Data Ready 1.

Table continues on the next page...

I²Sx_ISR field descriptions (continued)

Field	Description
	<p>This flag bit is set when RX1 or Rx FIFO 1 is loaded with a new value and two-channel mode is selected. RDR1 is cleared when the core reads the RX1 register. If Rx FIFO 1 is enabled, RDR1 is cleared when the FIFO is empty. If IER[R1E] and IER[RDR1EN] are set, a receive data 1 interrupt request is issued on setting of RDR1 bit in case Rx FIFO1 is disabled, if the FIFO is enabled, the interrupt is issued on RFF1 assertion. The RDR1 bit is cleared by POR and I²S reset.</p> <p>0 No new data for core to read. 1 New data for core to read.</p>
14 RDR0	<p>Receive Data Ready 0.</p> <p>This flag bit is set when RX0 or Rx FIFO 0 is loaded with a new value. RDR0 is cleared when the core reads the RX0 register. If Rx FIFO 0 is enabled, RDR0 is cleared when the FIFO is empty. If IER[R0E] and IER[RDR0EN] are set, a receive data 0 interrupt request is issued on setting of RDR0 bit in case Rx FIFO0 is disabled, if the FIFO is enabled, the interrupt is issued on RFF0 assertion. The RDR0 bit is cleared by POR and I²S reset.</p> <p>0 No new data for core to read. 1 New data for core to read.</p>
13 TDE1	<p>Transmit Data Register Empty 1.</p> <p>This flag is set whenever data is transferred to TXSR from TX1 register and two-channel mode is selected. If Tx FIFO1 is enabled, this occurs when there is at least one empty slot in TX1 or Tx FIFO1. If Tx FIFO1 is not enabled, this occurs when the contents of TX1 are transferred to TXSR.</p> <p>The TDE1 bit is cleared when the core writes to TX1. If IER[T1E] and IER[TDE1EN] are set, an I²S transmit data 1 interrupt request is issued on setting of TDE1 bit. The TDE1 bit is cleared by POR and I²S reset.</p> <p>0 Data available for transmission. 1 Data needs to be written by the core for transmission.</p>
12 TDE0	<p>Transmit Data Register Empty 0.</p> <p>This flag is set whenever data is transferred to TXSR from TX0 register. If Tx FIFO 0 is enabled, this occurs when there is at least one empty slot in TX0 or Tx FIFO 0. If Tx FIFO 0 is not enabled, this occurs when the contents of TX0 are transferred to TXSR. The TDE0 bit is cleared when the core writes to TX0. If IER[T0E] and IER[TDE0EN] are set, an I²S transmit data 0 interrupt request is issued on setting of TDE0 bit. The TDE0 bit is cleared by POR and I²S reset.</p> <p>0 Data available for transmission. 1 Data needs to be written by the core for transmission.</p>
11 ROE1	<p>Receiver Overrun Error 1.</p> <p>This flag is set when the RXSR is filled and ready to transfer to RX1 register or to Rx FIFO 1 (when enabled) and these are already full and Two-Channel mode is selected. If Rx FIFO 1 is enabled, this is indicated by RFF1 flag, else this is indicated by the RDR1 flag. The RXSR is not transferred in this case. The ROE1 flag causes an interrupt if IER[R1E] and IER[ROE1EN] are set.</p> <p>The ROE1 bit is cleared by POR and I²S reset. It is also cleared by writing '1' to this bit. Clearing the CR[RE] bit does not affect the ROE1 bit.</p> <p>0 No overrun detected 1 Receiver overrun error occurred</p>
10 ROE0	<p>Receiver Overrun Error 0.</p>

Table continues on the next page...

I2Sx_ISR field descriptions (continued)

Field	Description
	<p>This flag is set when the RXSR is filled and ready to transfer to RX0 register or to Rx FIFO 0 (when enabled) and these are already full. If Rx FIFO 0 is enabled, this is indicated by RFF0 flag, else this is indicated by the RDR0 flag. The RXSR is not transferred in this case. The ROE0 flag causes an interrupt if IER[RIE] and IER[ROE0EN] are set.</p> <p>The ROE0 bit is cleared by POR and I²S reset. It is also cleared by writing `1' to this bit. Clearing the CR[RE] bit does not affect the ROE0 bit.</p> <p>0 No overrun detected 1 Receiver overrun error occurred</p>
9 TUE1	<p>Transmitter Underrun Error 1.</p> <p>This flag is set when the TXSR is empty (no data to be transmitted), the TDE1 flag is set, a transmit time slot occurs and the I²S is in two-channel mode. When a transmit underrun error occurs, the previous data is retransmitted. In Network mode, each time slot requires data transmission (unless masked through TMSK register), when the transmitter is enabled (CR[TE] is set).</p> <p>The TUE1 flag causes an interrupt if IER[TIE] and IER[TUE1EN] are set.</p> <p>The TUE1 bit is cleared by POR and I²S reset. It is also cleared by writing `1' to this bit.</p> <p>0 No underrun detected 1 Transmitter underrun error occurred</p>
8 TUE0	<p>Transmitter Underrun Error 1.</p> <p>This flag is set when the TXSR is empty (no data to be transmitted), the TDE0 flag is set and a transmit time slot occurs. When a transmit underrun error occurs, the previous data is retransmitted. In Network mode, each time slot requires data transmission (unless masked through TMSK register), when the transmitter is enabled (CR[TE] is set). The TUE0 flag causes an interrupt if IER[TIE] and IER[TUE0EN] are set.</p> <p>The TUE0 bit is cleared by POR and I²S reset. It is also cleared by writing `1' to this bit.</p> <p>0 No underrun detected 1 Transmitter underrun error occurred</p>
7 TFS	<p>Transmit Frame Sync.</p> <p>This flag indicates the occurrence of transmit frame sync. Data written to the TX registers during the time slot when the TFS flag is set, is sent during the second time slot (in network mode) or in the next first time slot (in normal mode). In network mode, the TFS bit is set during transmission of the first time slot of the frame and is then cleared when starting transmission of the next time slot. In normal mode, this bit is high for the first time slot. This flag causes an interrupt if IER[TIE] and IER[TFSEN] are set. The TFS bit is cleared by POR and I²S reset.</p> <p>0 No occurrence of transmit frame sync. 1 Transmit frame sync occurred during transmission of last word written to TX registers.</p>
6 RFS	<p>Receive Frame Sync.</p> <p>This flag indicates the occurrence of receive frame sync. In network mode, the RFS bit is set when the first slot of the frame is being received. It is cleared when the next slot begins to be received. In normal mode, this bit is always high. This flag causes an interrupt if IER[RIE] and IER[RFSEN] are set. The RFS bit is cleared by POR and I²S reset.</p> <p>0 No occurrence of receive frame sync. 1 Receive frame sync occurred during reception of next word in RX registers.</p>

Table continues on the next page...

I2Sx_ISR field descriptions (continued)

Field	Description
5 TLS	<p>Transmit Last Time Slot.</p> <p>This flag indicates the last time slot in a frame. When set, it indicates that the current time slot is the last time slot of the frame. TLS is set at the start of the last transmit time slot and causes the I²S to issue an interrupt (if IER[TIE] and TLSEN are set). TLS is not generated when frame rate is 1 in normal mode of operation. TLS is cleared when the ISR is read with this bit set. The TLS bit is cleared by POR and I²S reset.</p> <p>0 Current time slot is not last time slot of frame. 1 Current time slot is the last transmit time slot of frame.</p>
4 RLS	<p>Receive Last Time Slot.</p> <p>This flag indicates the last time slot in a frame. When set, it indicates that the current time slot is the last receive time slot of the frame. RLS is set at the end of the last time slot and causes the I²S to issue an interrupt (if IER[RIE] and IER[RLSEN] are set). RLS is cleared when the ISR is read with this bit set. The RLS bit is cleared by POR and I²S reset.</p> <p>0 Current time slot is not last time slot of frame. 1 Current time slot is the last receive time slot of frame.</p>
3 RFF1	<p>Receive FIFO Full 1.</p> <p>This flag is set when Rx FIFO1 is enabled, the data level in Rx FIFO1 reaches the selected Rx FIFO WaterMark 1 (RFWM1) threshold and the I²S is in two-channel mode. The setting of RFF1 only causes an interrupt when IER[RIE] and IER[RFF1EN] are set, Rx FIFO1 is enabled and the two-channel mode is selected. RFF1 is automatically cleared when the amount of data in Rx FIFO1 falls below the threshold. The RFF1 bit is cleared by POR and I²S reset.</p> <p>When Rx FIFO1 contains 15 words, the maximum it can hold, all further data received (for storage in this FIFO) is ignored until the FIFO contents are read.</p> <p>0 Space available in receive FIFO1. 1 Receive FIFO1 is full.</p>
2 RFF0	<p>Receive FIFO Full 0.</p> <p>This flag is set when Rx FIFO0 is enabled and the data level in Rx FIFO0 reaches the selected Rx FIFO WaterMark 0 (RFWM0) threshold. The setting of RFF0 only causes an interrupt when IER[RIE] and IER[RFF0EN] are set and Rx FIFO0 is enabled. RFF0 is automatically cleared when the amount of data in Rx FIFO0 falls below the threshold. The RFF0 bit is cleared by POR and I²S reset.</p> <p>When Rx FIFO0 contains 15 words, the maximum it can hold, all further data received (for storage in this FIFO) is ignored until the FIFO contents are read.</p> <p>0 Space available in receive FIFO0. 1 Receive FIFO0 is full.</p>
1 TFE1	<p>Transmit FIFO Empty 1.</p> <p>This flag is set when the empty slots in Tx FIFO exceed or are equal to the selected Tx FIFO WaterMark 1 (TFWM1) threshold and the two-channel mode is selected. The setting of TFE1 only causes an interrupt when IER[TIE] and IER[TFE1EN] are set, Tx FIFO1 is enabled and two-channel mode is selected. The TFE1 bit is automatically cleared when the data level in Tx FIFO1 becomes more than the amount specified by the watermark bits. The TFE1 bit is set by POR and I²S reset.</p> <p>0 Transmit FIFO1 has data for transmission. 1 Transmit FIFO1 is empty.</p>

Table continues on the next page...

I2Sx_ISR field descriptions (continued)

Field	Description
0 TFE0	<p>Transmit FIFO Empty 0.</p> <p>This flag is set when the empty slots in Tx FIFO exceed or are equal to the selected Tx FIFO WaterMark 0 (TFWM0) threshold. The setting of TFE0 only causes an interrupt when IER[TIE] and IER[TFE0EN] are set and Tx FIFO0 is enabled. The TFE0 bit is automatically cleared when the data level in Tx FIFO0 becomes more than the amount specified by the watermark bits. The TFE0 bit is set by POR and I²S reset.</p> <p>0 Transmit FIFO0 has data for transmission. 1 Transmit FIFO0 is empty.</p>

49.3.7 I²S Interrupt Enable Register (I2Sx_IER)

The I2S interrupt enable register (IER) is a 25-bit register used to set up the I2S interrupts and DMA requests.

Addresses: I2S0_IER is 4002_F000h base + 18h offset = 4002_F018h

Bit	31	30	29	28	27	26	25	24	23	22	21	20	19	18	17	16	
R	0								RFRC_EN	TFRC_EN	RDMAE	RIE	TDMAE	TIE	CMDAEN	CMDDUEN	RXTEN
W	[Shaded]								RFRC_EN	TFRC_EN	RDMAE	RIE	TDMAE	TIE	CMDAEN	CMDDUEN	RXTEN
Reset	0	0	0	0	0	0	0	0	0	0	0	0	0	0	0	0	0
Bit	15	14	13	12	11	10	9	8	7	6	5	4	3	2	1	0	
R	RDR1EN	RDR0EN	TDE1EN	TDE0EN	ROE1EN	ROE0EN	TUE1EN	TUE0EN	TFSEN	RFSEN	TLSEN	RLSEN	RFF1EN	RFF0EN	TFE1EN	TFE0EN	
W	RDR1EN	RDR0EN	TDE1EN	TDE0EN	ROE1EN	ROE0EN	TUE1EN	TUE0EN	TFSEN	RFSEN	TLSEN	RLSEN	RFF1EN	RFF0EN	TFE1EN	TFE0EN	
Reset	0	0	1	1	0	0	0	0	0	0	0	0	0	0	1	1	

I2Sx_IER field descriptions

Field	Description
31–25 Reserved	This read-only field is reserved and always has the value zero.
24 RFRC_EN	<p>Enable Bit.</p> <p>Each bit controls whether the corresponding status bit in ISR can issue an interrupt to the core or not.</p> <p>0 Corresponding status bit cannot issue interrupt. 1 Corresponding status bit can issue interrupt.</p>
23 TFRC_EN	<p>Enable Bit.</p> <p>Each bit controls whether the corresponding status bit in ISR can issue an interrupt to the core or not.</p>

Table continues on the next page...

I2Sx_IER field descriptions (continued)

Field	Description
	<p>0 Corresponding status bit cannot issue interrupt. 1 Corresponding status bit can issue interrupt.</p>
22 RDMAE	<p>Receive DMA Enable.</p> <p>This bit allows I²S to request for DMA transfers. When enabled, DMA requests are generated when any of the RFF0/1 bits in the ISR are set and if the corresponding RFEN bit is also set. If the corresponding FIFO is disabled, a DMA request is generated when the corresponding RDR bit is set.</p> <p>0 I²S receiver DMA requests disabled. 1 I²S receiver DMA requests enabled.</p>
21 RIE	<p>Receive Interrupt Enable.</p> <p>This control bit allows the I²S to issue receiver related interrupts to the core.</p> <p>0 I²S receiver interrupt requests disabled. 1 I²S receiver interrupt requests enabled.</p>
20 TDMAE	<p>Transmit DMA Enable.</p> <p>This bit allows I²S to request for DMA transfers. When enabled, DMA requests are generated when any of the ISR[TFE0/1] bits are set and if the corresponding TCR[TFEN] bit is also set. If the corresponding FIFO is disabled, a DMA request is generated when the corresponding TDE bit is set.</p> <p>0 I²S transmitter DMA requests disabled. 1 I²S transmitter DMA requests enabled.</p>
19 TIE	<p>Transmit Interrupt Enable.</p> <p>This control bit allows the I²S to issue transmitter data related interrupts to the core.</p> <p>0 I²S transmitter interrupt requests disabled. 1 I²S transmitter interrupt requests enabled.</p>
18 CMDAEN	<p>Enable Bit.</p> <p>Each bit controls whether the corresponding status bit in ISR can issue an interrupt to the core or not.</p> <p>0 Corresponding status bit cannot issue interrupt. 1 Corresponding status bit can issue interrupt.</p>
17 CMDDUEN	<p>Enable Bit.</p> <p>Each bit controls whether the corresponding status bit in ISR can issue an interrupt to the core or not.</p> <p>0 Corresponding status bit cannot issue interrupt. 1 Corresponding status bit can issue interrupt.</p>
16 RXTEN	<p>Enable Bit.</p> <p>Each bit controls whether the corresponding status bit in ISR can issue an interrupt to the core or not.</p> <p>0 Corresponding status bit cannot issue interrupt. 1 Corresponding status bit can issue interrupt.</p>
15 RDR1EN	<p>Enable Bit.</p>

Table continues on the next page...

I2Sx_IER field descriptions (continued)

Field	Description
	Each bit controls whether the corresponding status bit in ISR can issue an interrupt to the core or not. 0 Corresponding status bit cannot issue interrupt. 1 Corresponding status bit can issue interrupt.
14 RDR0EN	Enable Bit. Each bit controls whether the corresponding status bit in ISR can issue an interrupt to the core or not. 0 Corresponding status bit cannot issue interrupt. 1 Corresponding status bit can issue interrupt.
13 TDE1EN	Enable Bit. Each bit controls whether the corresponding status bit in ISR can issue an interrupt to the core or not. 0 Corresponding status bit cannot issue interrupt. 1 Corresponding status bit can issue interrupt.
12 TDE0EN	Enable Bit. Each bit controls whether the corresponding status bit in ISR can issue an interrupt to the core or not. 0 Corresponding status bit cannot issue interrupt. 1 Corresponding status bit can issue interrupt.
11 ROE1EN	Enable Bit. Each bit controls whether the corresponding status bit in ISR can issue an interrupt to the core or not. 0 Corresponding status bit cannot issue interrupt. 1 Corresponding status bit can issue interrupt.
10 ROE0EN	Enable Bit. Each bit controls whether the corresponding status bit in ISR can issue an interrupt to the core or not. 0 Corresponding status bit cannot issue interrupt. 1 Corresponding status bit can issue interrupt.
9 TUE1EN	Enable Bit. Each bit controls whether the corresponding status bit in ISR can issue an interrupt to the core or not. 0 Corresponding status bit cannot issue interrupt. 1 Corresponding status bit can issue interrupt.
8 TUE0EN	Enable Bit. Each bit controls whether the corresponding status bit in ISR can issue an interrupt to the core or not. 0 Corresponding status bit cannot issue interrupt. 1 Corresponding status bit can issue interrupt.
7 TFSEN	Enable Bit. Each bit controls whether the corresponding status bit in ISR can issue an interrupt to the core or not.

Table continues on the next page...

I2Sx_IER field descriptions (continued)

Field	Description
	<p>0 Corresponding status bit cannot issue interrupt. 1 Corresponding status bit can issue interrupt.</p>
6 RFSEN	<p>Enable Bit.</p> <p>Each bit controls whether the corresponding status bit in ISR can issue an interrupt to the core or not.</p> <p>0 Corresponding status bit cannot issue interrupt. 1 Corresponding status bit can issue interrupt.</p>
5 TLSEN	<p>Enable Bit.</p> <p>Each bit controls whether the corresponding status bit in ISR can issue an interrupt to the core or not.</p> <p>0 Corresponding status bit cannot issue interrupt. 1 Corresponding status bit can issue interrupt.</p>
4 RLSEN	<p>Enable Bit.</p> <p>Each bit controls whether the corresponding status bit in ISR can issue an interrupt to the core or not.</p> <p>0 Corresponding status bit cannot issue interrupt. 1 Corresponding status bit can issue interrupt.</p>
3 RFF1EN	<p>Enable Bit.</p> <p>Each bit controls whether the corresponding status bit in ISR can issue an interrupt to the core or not.</p> <p>0 Corresponding status bit cannot issue interrupt. 1 Corresponding status bit can issue interrupt.</p>
2 RFF0EN	<p>Enable Bit.</p> <p>Each bit controls whether the corresponding status bit in ISR can issue an interrupt to the core or not.</p> <p>0 Corresponding status bit cannot issue interrupt. 1 Corresponding status bit can issue interrupt.</p>
1 TFE1EN	<p>Enable Bit.</p> <p>Each bit controls whether the corresponding status bit in ISR can issue an interrupt to the core or not.</p> <p>0 Corresponding status bit cannot issue interrupt. 1 Corresponding status bit can issue interrupt.</p>
0 TFE0EN	<p>Enable Bit.</p> <p>Each bit controls whether the corresponding status bit in ISR can issue an interrupt to the core or not.</p> <p>0 Corresponding status bit cannot issue interrupt. 1 Corresponding status bit can issue interrupt.</p>

49.3.8 I²S Transmit Configuration Register (I2Sx_TCR)

The TCR directs the transmit operation of the I2S. A power-on reset clears all TCR bits. However, I2S reset does not affect the TCR bits.

Addresses: I2S0_TCR is 4002_F000h base + 1Ch offset = 4002_F01Ch

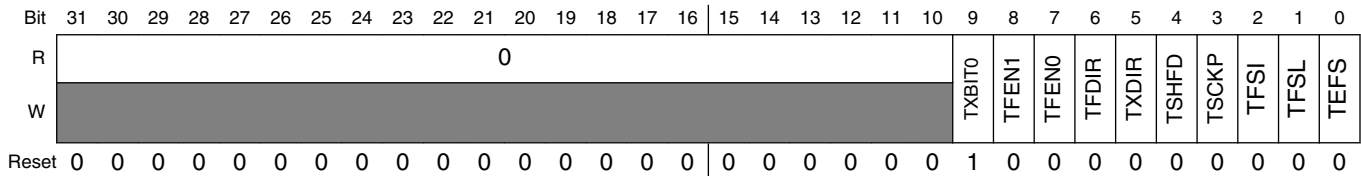

I2Sx_TCR field descriptions

Field	Description
31–10 Reserved	This read-only field is reserved and always has the value zero.
9 TXBIT0	<p>Transmit Bit 0.</p> <p>This control bit allows I²S to transmit the data word from bit position 0 or 15/31 in the transmit shift register. The shifting data direction can be MSB or LSB first, controlled by the TCR[TSHFD] bit.</p> <p>0 Shifting with respect to bit 31 (if word length = 16, 18, 20, 22 or 24) or bit 15 (if word length = 8, 10 or 12) of transmit shift register (MSB aligned).</p> <p>1 Shifting with respect to bit 0 of transmit shift register (LSB aligned).</p>
8 TFEN1	<p>Transmit FIFO Enable 1.</p> <p>This bit enables transmit FIFO 1. When enabled, the FIFO allows 15 samples to be transmitted by the I²S (per channel) (a 9th sample can be shifting out) before TDE1 bit is set. When the FIFO is disabled, an interrupt is generated when a single sample is transferred to the transmit shift register (provided the interrupt is enabled).</p> <p>0 Transmit FIFO 1 disabled.</p> <p>1 Transmit FIFO 1 enabled.</p>
7 TFEN0	<p>Transmit FIFO Enable 0.</p> <p>This bit enables transmit FIFO 0. When enabled, the FIFO allows 15 samples to be transmitted by the I²S per channel (a 9th sample can be shifting out) before TDE0 bit is set. When the FIFO is disabled, an interrupt is generated when a single sample is transferred to the transmit shift register (provided the interrupt is enabled).</p> <p>0 Transmit FIFO 0 disabled.</p> <p>1 Transmit FIFO 0 enabled.</p>
6 TFDIR	<p>Transmit Frame Direction.</p> <p>This bit controls the direction and source of the transmit frame sync signal. Internally generated frame sync signal is sent out through the STFS port and external frame sync is taken from the same port.</p> <p>0 Frame sync is external.</p> <p>1 Frame sync generated internally.</p>

Table continues on the next page...

I2Sx_TCR field descriptions (continued)

Field	Description
5 TXDIR	<p>Transmit clock direction</p> <p>This bit controls the direction and source of the clock signal used to clock the TXSR. Internally generated clock is output through the STCK port. External clock is taken from this port.</p> <p>0 Transmit clock is external. 1 Transmit clock generated internally</p>
4 TSHFD	<p>Transmit Shift Direction.</p> <p>This bit controls whether the MSB or LSB will be transmitted first in a sample.</p> <p>NOTE: The CODEC device labels the MSB as bit 0, whereas the core labels the LSB as bit 0. Therefore, when using a standard CODEC, core MSB (CODEC LSB) is shifted in first (TCR[TSHFD] cleared).</p> <p>0 Data transmitted MSB first. 1 Data transmitted LSB first.</p>
3 TSCKP	<p>Transmit Clock Polarity.</p> <p>This bit controls which bit clock edge is used to clock out data for the transmit section.</p> <p>NOTE: TSCKP is 0 CLKIST = 0; TSCKP is 1 CLKIST = 1</p> <p>0 Data clocked out on rising edge of bit clock. 1 Data clocked out on falling edge of bit clock.</p>
2 TFSI	<p>Transmit Frame Sync Invert.</p> <p>This bit controls the active state of the frame sync I/O signal for the transmit section of I²S.</p> <p>0 Transmit frame sync is active high. 1 Transmit frame sync is active low.</p>
1 TFSL	<p>Transmit Frame Sync Length.</p> <p>This bit controls the length of the frame sync signal to be generated or recognized for the transmit section. The length of a word-long frame sync is same as the length of the data word selected by WL[3:0].</p> <p>0 Transmit frame sync is one-word long. 1 Transmit frame sync is one-clock-bit long.</p>
0 TEFS	<p>Transmit Early Frame Sync.</p> <p>This bit controls when the frame sync is initiated for the transmit section. The frame sync signal is deasserted after one bit-for-bit length frame sync and after one word-for-word length frame sync. In case of synchronous operation, the frame sync can also be initiated on receiving the first bit of data.</p> <p>0 Transmit frame sync initiated as the first bit of data is transmitted. 1 Transmit frame sync is initiated one bit before the data is transmitted.</p>

49.3.9 I²S Receive Configuration Register (I2Sx_RCR)

RCR directs the receive operation of the I2S. A power-on reset clears all RCR bits. However, I2S reset does not affect the RCR bits.

Addresses: I2S0_RCR is 4002_F000h base + 20h offset = 4002_F020h

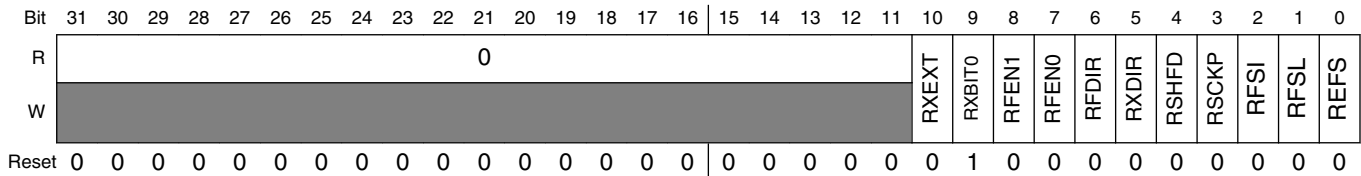

I2Sx_RCR field descriptions

Field	Description
31–11 Reserved	This read-only field is reserved and always has the value zero.
10 RXEXT	Receive Data Extension. This control bit allows I ² S to store the received data word in sign extended form. This bit affects data storage only in case received data is LSB aligned (RCR[9]=1) 0 Sign extension turned off. 1 Sign extension turned on.
9 RXBIT0	Receive Bit 0. This control bit allows I ² S to receive the data word at bit position 0 or 15/31 in the receive shift register. The shifting data direction can be MSB or LSB first, controlled by the RSHFD bit. 0 Shifting with respect to bit 31 (if word length = 16, 18, 20, 22 or 24) or bit 15 (if word length = 8, 10 or 12) of receive shift register (MSB aligned). 1 Shifting with respect to bit 0 of receive shift register (LSB aligned).
8 RFEN1	Receive FIFO Enable 1. This bit enables receive FIFO 1. When enabled, the FIFO allows 15 samples to be received by the I ² S per channel (a 16th sample can be shifting in) before RDR1 bit is set. When the FIFO is disabled, an interrupt is generated when a single sample is received by the I ² S (provided the interrupt is enabled). 0 Receive FIFO 1 disabled. 1 Receive FIFO 1 enabled.
7 RFEN0	Receive FIFO Enable 0. This bit enables receive FIFO 0. When enabled, the FIFO allows 15 samples to be received by the I ² S (per channel) (a 16th sample can be shifting in) before RDR0 bit is set. When the FIFO is disabled, an interrupt is generated when a single sample is received by the I ² S (provided the interrupt is enabled). 0 Receive FIFO 0 disabled. 1 Receive FIFO 0 enabled.
6 RFDIR	Receive Frame Direction.

Table continues on the next page...

I2Sx_RCR field descriptions (continued)

Field	Description
	<p>This bit controls the direction and source of the receive frame sync signal. Internally generated frame sync signal is sent out through the SRFS port and external frame sync is taken from the same port.</p> <p>0 Frame Sync is external. 1 Frame Sync generated internally.</p>
5 RXDIR	<p>Receive Clock Direction.</p> <p>This bit controls the direction and source of the clock signal used to clock the RXSR. Internally generated clock is output through the SRCK port. External clock is taken from this port.</p> <p>0 Receive Clock is external. 1 Receive Clock generated internally.</p>
4 RSHFD	<p>Receive Shift Direction.</p> <p>This bit controls whether the MSB or LSB will be received first in a sample.</p> <p>NOTE: The CODEC device labels the MSB as bit 0, whereas the Core labels the LSB as bit 0. Therefore, when using a standard CODEC, Core MSB (CODEC LSB) is shifted in first (RSHFD cleared).</p> <p>0 Data received MSB first. 1 Data received LSB first.</p>
3 RSCKP	<p>Receive Clock Polarity.</p> <p>This bit controls which bit clock edge is used to latch in data for the receive section.</p> <p>0 Data latched on falling edge of bit clock. 1 Data latched on rising edge of bit clock.</p>
2 RFSI	<p>Receive Frame Sync Invert.</p> <p>This bit controls the active state of the frame sync I/O signal for the receive section of I²S.</p> <p>0 Receive frame sync is active high. 1 Receive frame sync is active low.</p>
1 RFSL	<p>Receive Frame Sync Length.</p> <p>This bit controls the length of the frame sync signal to be generated or recognized for the receive section. The length of a word-long frame sync is same as the length of the data word selected by WL[3:0].</p> <p>0 Receive frame sync is one-word long. 1 Receive frame sync is one-clock-bit long.</p>
0 REFS	<p>Receive Early Frame Sync.</p> <p>This bit controls when the frame sync is initiated for the receive section. The frame sync is disabled after one bit-for-bit length frame sync and after one word-for-word length frame sync.</p> <p>0 Receive frame sync initiated as the first bit of data is received. 1 Receive frame sync is initiated one bit before the data is received.</p>

49.3.10 I²S Transmit Clock Control Registers (I2Sx_TCCR)

The I2S Transmit and Receive Control (TCCR and RCCR) registers are 19-bit, read/write control registers used to direct the operation of the I2S. The Clock and Reset Module (CRM) can source the I2S clock (network clock) from multiple sources and perform fractional division to support commonly used audio bit rates. The CRM can maintain the network clock frequency at a constant rate even in cases where the peripheral clock frequency changes. These registers control the I2S clock generator, bit and frame sync rates, word length, and number of words per frame for the serial data. The TCCR register is dedicated to the transmit section, and the RCCR register is dedicated to the receive section except in Synchronous mode, in which the TCCR register controls both the receive and transmit sections. Power-on reset clears all TCCR and RCCR bits. I2S reset does not affect the TCCR and RCCR bits. The control bits are described in the following paragraphs. Although the bit patterns of the TCCR and RCCR registers are the same, the contents of these two registers can be programmed differently.

Addresses: I2S0_TCCR is 4002_F000h base + 24h offset = 4002_F024h

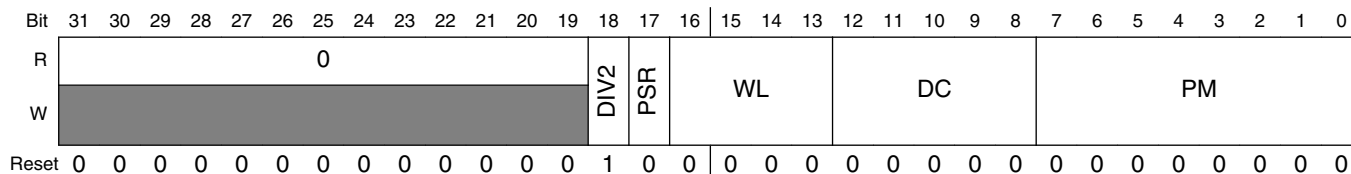

I2Sx_TCCR field descriptions

Field	Description
31–19 Reserved	This read-only field is reserved and always has the value zero.
18 DIV2	Divide By 2. This bit controls a divide-by-two divider in series with the rest of the prescalers. 0 Divider bypassed. 1 Divider used to divide clock by 2.
17 PSR	Prescaler Range. This bit controls a fixed divide-by-eight prescaler in series with the variable prescaler. It extends the range of the prescaler for those cases where a slower bit clock is required. 0 Prescaler bypassed. 1 Prescaler used to divide clock by 8.
16–13 WL	Word Length Control. Specifies the number of bits per data word being transferred by the I ² S. These bits control the Word Length Divider in the Clock Generator. They also control the frame sync pulse length when the FSL bit is cleared. In I2S Master mode, the I ² S works with a fixed word length of 32, and the WL bits are used to

Table continues on the next page...

I2Sx_TCCR field descriptions (continued)

Field	Description
	<p>control the amount of valid data in those 32 bits. In AC97 Mode of operation, if word length is set to any value other than 16 bits, it will result in a word length of 20 bits.</p> <p>0000 Reserved. Do not program this value. 0001 Reserved. Do not program this value. 0010 Reserved. Do not program this value. 0011 8 0100 10 0101 12 0110 Reserved. Do not program this value. 0111 16 1000 18 1001 20 1010 22 1011 24 1100 Reserved. Do not program this value. 1101 Reserved. Do not program this value. 1110 Reserved. Do not program this value. 1111 Reserved. Do not program this value.</p>
<p>12–8 DC</p>	<p>Frame Rate Divider Control.</p> <p>These bits are used to control the divide ratio for the programmable frame rate dividers. The divide ratio works on the word clock. In Normal mode, this ratio determines the word transfer rate. In Network mode, this ratio sets the number of words per frame. The divide ratio ranges from 1 to 32 in Normal mode and from 2 to 32 in Network mode. In Normal mode, a divide ratio of 1 (DC=00000) provides continuous periodic data word transfer. A bit-length frame sync must be used in this case.</p> <p>These bits can be programmed with values ranging from "00000" to "11111" to control the number of words in a frame.</p>
<p>7–0 PM</p>	<p>Prescaler Modulus Select.</p> <p>These bits control the prescale divider in the clock generator. This prescaler is used only in Internal Clock mode to divide the internal clock . The bit clock output is available at the clock port. A divide ratio from 1 to 256 (PM[7:0] = 0x00 to 0xFF) can be selected.</p>

49.3.11 I²S Receive Clock Control Registers (I2Sx_RCCR)

The I2S Transmit and Receive Control (TCCR and RCCR) registers are 19-bit, read/write control registers used to direct the operation of the I2S. The Clock and Reset Module (CRM) can source the I2S clock (network clock) from multiple sources and perform fractional division to support commonly used audio bit rates. The CRM can maintain the network clock frequency at a constant rate even in cases where the peripheral clock frequency changes. These registers control the I2S clock generator, bit and frame sync rates, word length, and number of words per frame for the serial data. The TCCR register is dedicated to the transmit section, and the RCCR register is dedicated to the receive section except in Synchronous mode, in which the TCCR register controls both the receive and transmit sections. Power-on reset clears all TCCR and RCCR bits. I2S reset does not affect the TCCR and RCCR bits. The control bits are described in the following paragraphs. Although the bit patterns of the TCCR and RCCR registers are the same, the contents of these two registers can be programmed differently.

Addresses: I2S0_RCCR is 4002_F000h base + 28h offset = 4002_F028h

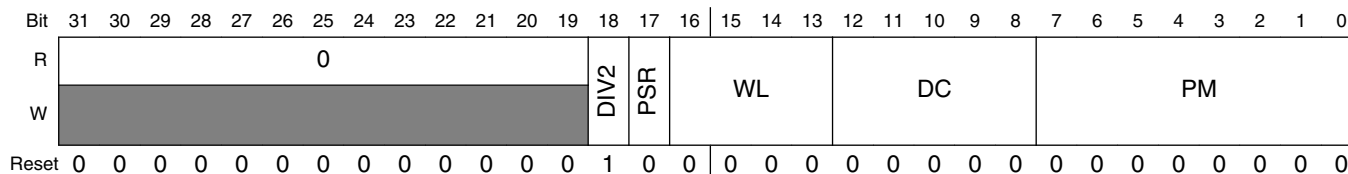

I2Sx_RCCR field descriptions

Field	Description
31–19 Reserved	This read-only field is reserved and always has the value zero.
18 DIV2	Divide By 2. This bit controls a divide-by-two divider in series with the rest of the prescalers. 0 Divider bypassed. 1 Divider used to divide clock by 2.
17 PSR	Prescaler Range. This bit controls a fixed divide-by-eight prescaler in series with the variable prescaler. It extends the range of the prescaler for those cases where a slower bit clock is required. 0 Prescaler bypassed. 1 Prescaler used to divide clock by 8.
16–13 WL	Word Length Control. These bits are used to control the length of the data words being transferred by the I ² S. These bits control the Word Length Divider in the Clock Generator. They also control the frame sync pulse length when the FSL bit is cleared. In I2S Master mode, the I ² S works with a fixed word length of 32, and the WL bits are

Table continues on the next page...

I2Sx_RCCR field descriptions (continued)

Field	Description
	<p>used to control the amount of valid data in those 32 bits. In AC97 Mode of operation, if word length is set to any value other than 16 bits, it will result in a word length of 20 bits.</p> <p>0000 Number of Bits/Word: 2; Supported in Implementation: No. 0001 Number of Bits/Word: 4; Supported in Implementation: No. 0010 Number of Bits/Word: 6; Supported in Implementation: No. 0011 Number of Bits/Word: 8; Supported in Implementation: Yes. 0100 Number of Bits/Word: 10; Supported in Implementation: Yes. 0101 Number of Bits/Word: 12; Supported in Implementation: Yes. 0110 Number of Bits/Word: 14; Supported in Implementation: No. 0111 Number of Bits/Word: 16; Supported in Implementation: Yes. 1000 Number of Bits/Word: 18; Supported in Implementation: Yes. 1001 Number of Bits/Word: 20; Supported in Implementation: Yes. 1010 Number of Bits/Word: 22; Supported in Implementation: Yes. 1011 Number of Bits/Word: 24; Supported in Implementation: Yes. 1100 Number of Bits/Word: 26; Supported in Implementation: No. 1101 Number of Bits/Word: 28; Supported in Implementation: No. 1110 Number of Bits/Word: 30; Supported in Implementation: No. 1111 Number of Bits/Word: 32; Supported in Implementation: No.</p>
12–8 DC	<p>Frame Rate Divider Control.</p> <p>These bits are used to control the divide ratio for the programmable frame rate dividers. The divide ratio works on the word clock. In Normal mode, this ratio determines the word transfer rate. In Network mode, this ratio sets the number of words per frame. The divide ratio ranges from 1 to 32 in Normal mode and from 2 to 32 in Network mode. In Normal mode, a divide ratio of 1 (DC=00000) provides continuous periodic data word transfer. A bit-length frame sync must be used in this case.</p> <p>These bits can be programmed with values ranging from "00000" to "11111" to control the number of words in a frame.</p>
7–0 PM	<p>Prescaler Modulus Select.</p> <p>These bits control the prescale divider in the clock generator. This prescaler is used only in Internal Clock mode to divide the internal clock. The bit clock output is available at the clock port. A divide ratio from 1 to 256 (PM[7:0] = 0x00 to 0xFF) can be selected.</p>

49.3.12 I²S FIFO Control/Status Register (I2Sx_FCSR)

The following table indicates the status of the Transmit FIFO Empty flag, with different settings of the Transmit FIFO WaterMark bits and varying amounts of data in the Tx FIFO.

Table 49-40. Status of Transmit FIFO Empty Flag

Transmit FIFO Watermark (TFWM)	1	2	3	4	5	6	7	8	9	10	11	12	13	14	15
1	1	1	1	1	1	1	1	1	1	1	1	1	1	1	0

Table continues on the next page...

Table 49-40. Status of Transmit FIFO Empty Flag (continued)

Transmit FIFO Watermark (TFWM)	1	2	3	4	5	6	7	8	9	10	11	12	13	14	15
2	1	1	1	1	1	1	1	1	1	1	1	1	1	0	0
3	1	1	1	1	1	1	1	1	1	1	1	1	0	0	0
4	1	1	1	1	1	1	1	1	1	1	1	0	0	0	0
5	1	1	1	1	1	1	1	1	1	1	0	0	0	0	0
6	1	1	1	1	1	1	1	1	1	0	0	0	0	0	0
7	1	1	1	1	1	1	1	1	0	0	0	0	0	0	0
8	1	1	1	1	1	1	1	0	0	0	0	0	0	0	0
9	1	1	1	1	1	1	0	0	0	0	0	0	0	0	0
10	1	1	1	1	1	0	0	0	0	0	0	0	0	0	0
11	1	1	1	1	0	0	0	0	0	0	0	0	0	0	0
12	1	1	1	0	0	0	0	0	0	0	0	0	0	0	0
13	1	1	0	0	0	0	0	0	0	0	0	0	0	0	0
14	1	0	0	0	0	0	0	0	0	0	0	0	0	0	0
15	0	0	0	0	0	0	0	0	0	0	0	0	0	0	0

Addresses: I2S0_FCSR is 4002_F000h base + 2Ch offset = 4002_F02Ch

Bit	31	30	29	28	27	26	25	24	23	22	21	20	19	18	17	16	15	14	13	12	11	10	9	8	7	6	5	4	3	2	1	0				
R	RFCNT1								TFCNT1				RFWM1				TFWM1				RFCNT0				TFCNT0				RFWM0				TFWM0			
W	0								0				1				0				0				0				1							
Reset	0								0				1				0				0				0				1							

I2Sx_FCSR field descriptions

Field	Description
31–28 RFCNT1	<p>Receive FIFO Counter1.</p> <p>These bits indicate the number of data words in Receive FIFO 1.</p> <p>0000 0 data word in receive FIFO. 0001 1 data word in receive FIFO. 0010 2 data word in receive FIFO. 0011 3 data word in receive FIFO. 0100 4 data word in receive FIFO. 0101 5 data word in receive FIFO. 0110 6 data word in receive FIFO. 0111 7 data word in receive FIFO. 1000 8 data word in receive FIFO. 1000 8 data word in receive FIFO. 1001 9 data word in receive FIFO. 1010 10 data word in receive FIFO. 1011 11 data word in receive FIFO.</p>

Table continues on the next page...

I2Sx_FCSR field descriptions (continued)

Field	Description
	1100 12 data word in receive FIFO. 1101 13 data word in receive FIFO. 1110 14 data word in receive FIFO. 1111 15 data word in receive FIFO.
27–24 TFCNT1	Transmit FIFO Counter1. These bits indicate the number of data words in Transmit FIFO. 0000 0 data word in transmit FIFO. 0001 1 data word in transmit FIFO. 0010 2 data word in transmit FIFO. 0011 3 data word in transmit FIFO. 0100 4 data word in transmit FIFO. 0101 5 data word in transmit FIFO. 0110 6 data word in transmit FIFO. 0111 7 data word in transmit FIFO. 1000 8 data word in transmit FIFO. 1001 9 data word in transmit FIFO. 1010 10 data word in transmit FIFO. 1011 11 data word in transmit FIFO. 1100 12 data word in transmit FIFO. 1101 13 data word in transmit FIFO. 1110 14 data word in transmit FIFO. 1111 15 data word in transmit FIFO.
23–20 RFWM1	Receive FIFO Full WaterMark 1. These bits control the threshold at which the RFF1 flag will be set. The RFF1 flag is set whenever the data level in Rx FIFO 1 reaches the selected threshold. 0000 Reserved 0001 RFF set when at least one data word have been written to the Receive FIFO Set when RxFIFO = 1,2.....15 data words 0010 RFF set when more than or equal to 2 data word have been written to the Receive FIFO. Set when RxFIFO = 2,3.....15 data words 0011 RFF set when more than or equal to 3 data word have been written to the Receive FIFO. Set when RxFIFO = 3,4.....15 data words 0100 RFF set when more than or equal to 4 data word have been written to the Receive FIFO. Set when RxFIFO = 4,5.....15 data words 0101 RFF set when more than or equal to 5 data word have been written to the Receive FIFO. Set when RxFIFO = 5,6.....15 data words 0110 RFF set when more than or equal to 6 data word have been written to the Receive. Set when RxFIFO = 6,7.....15 data words 0111 RFF set when more than or equal to 7 data word have been written to the Receive FIFO. Set when RxFIFO = 7,8.....15 data words 1000 RFF set when more than or equal to 8 data word have been written to the Receive FIFO. Set when RxFIFO = 8,9.....15 data words 1001 RFF set when more than or equal to 9 data word have been written to the Receive FIFO. Set when RxFIFO = 9,10.....15 data words

Table continues on the next page...

I2Sx_FCSR field descriptions (continued)

Field	Description
	<p>1010 RFF set when more than or equal to 10 data word have been written to the Receive FIFO. Set when RxFIFO = 10,11.....15 data words</p> <p>1011 RFF set when more than or equal to 11 data word have been written to the Receive FIFO. Set when RxFIFO = 11,12.....15 data words</p> <p>1100 RFF set when more than or equal to 12 data word have been written to the Receive FIFO. Set when RxFIFO = 12,13.....15 data words</p> <p>1101 RFF set when more than or equal to 13 data word have been written to the Receive FIFO. Set when RxFIFO = 13,14,15data words</p> <p>1110 RFF set when more than or equal to 14 data word have been written to the Receive FIFO. Set when RxFIFO = 14,15 data words</p> <p>1111 RFF set when 15 data word have been written to the Receive FIFO (default). Set when RxFIFO = 15 data words</p>
19–16 TFWM1	<p>Transmit FIFO Empty WaterMark 1.</p> <p>These bits control the threshold at which the TFE1 flag will be set. The TFE1 flag is set whenever the empty slots in Tx FIFO exceed or are equal to the selected threshold.</p> <p>0000 Reserved</p> <p>0001 TFE set when there are more than or equal to 1 empty slots in Transmit FIFO. (default) Transmit FIFO empty is set when TxFIFO ≤ 14 data.</p> <p>0010 TFE set when there are more than or equal to 2 empty slots in Transmit FIFO. (default) Transmit FIFO empty is set when TxFIFO ≤ 13 data.</p> <p>0011 TFE set when there are more than or equal to 3 empty slots in Transmit FIFO. (default) Transmit FIFO empty is set when TxFIFO ≤ 12 data.</p> <p>0100 TFE set when there are more than or equal to 4 empty slots in Transmit FIFO. (default) Transmit FIFO empty is set when TxFIFO ≤ 11 data.</p> <p>0101 TFE set when there are more than or equal to 5 empty slots in Transmit FIFO. (default) Transmit FIFO empty is set when TxFIFO ≤ 10 data.</p> <p>0110 TFE set when there are more than or equal to 6 empty slots in Transmit FIFO. (default) Transmit FIFO empty is set when TxFIFO ≤ 9 data.</p> <p>0111 TFE set when there are more than or equal to 7 empty slots in Transmit FIFO. (default) Transmit FIFO empty is set when TxFIFO ≤ 8 data.</p> <p>1000 TFE set when there are more than or equal to 8 empty slots in Transmit FIFO. (default) Transmit FIFO empty is set when TxFIFO ≤ 7 data.</p> <p>1001 TFE set when there are more than or equal to 9 empty slots in Transmit FIFO. (default) Transmit FIFO empty is set when TxFIFO ≤ 6 data.</p> <p>1010 TFE set when there are more than or equal to 10 empty slots in Transmit FIFO. (default) Transmit FIFO empty is set when TxFIFO ≤ 5 data.</p> <p>1011 TFE set when there are more than or equal to 11 empty slots in Transmit FIFO. (default) Transmit FIFO empty is set when TxFIFO ≤ 4 data.</p> <p>1100 TFE set when there are more than or equal to 12 empty slots in Transmit FIFO. (default) Transmit FIFO empty is set when TxFIFO ≤ 3 data.</p> <p>1101 TFE set when there are more than or equal to 13 empty slots in Transmit FIFO. (default) Transmit FIFO empty is set when TxFIFO ≤ 2 data.</p> <p>1110 TFE set when there are more than or equal to 14 empty slots in Transmit FIFO. (default) Transmit FIFO empty is set when TxFIFO ≤ 1 data.</p> <p>1000 TFE set when there are more than or equal to 15 empty slots in Transmit FIFO. (default) Transmit FIFO empty is set when TxFIFO ≤ 0 data.</p>
15–12 RFCNT0	<p>Receive FIFO Counter 0.</p>

Table continues on the next page...

I2Sx_FCSR field descriptions (continued)

Field	Description
	<p>These bits indicate the number of data words in Receive FIFO 0.</p> <p>0000 0 data word in receive FIFO. 0001 1 data word in receive FIFO. 0010 2 data word in receive FIFO. 0011 3 data word in receive FIFO. 0100 4 data word in receive FIFO. 0101 5 data word in receive FIFO. 0110 6 data word in receive FIFO. 0111 7 data word in receive FIFO. 1000 8 data word in receive FIFO. 1000 8 data word in receive FIFO. 1001 9 data word in receive FIFO. 1010 10 data word in receive FIFO. 1011 11 data word in receive FIFO. 1100 12 data word in receive FIFO. 1101 13 data word in receive FIFO. 1110 14 data word in receive FIFO. 1111 15 data word in receive FIFO.</p>
11–8 TFCNT0	<p>Transmit FIFO Counter 0.</p> <p>These bits indicate the number of data words in Transmit FIFO 0.</p> <p>0000 0 data word in transmit FIFO. 0001 1 data word in transmit FIFO. 0010 2 data word in transmit FIFO. 0011 3 data word in transmit FIFO. 0100 4 data word in transmit FIFO. 0101 5 data word in transmit FIFO. 0110 6 data word in transmit FIFO. 0111 7 data word in transmit FIFO. 1000 8 data word in transmit FIFO. 1001 9 data word in transmit FIFO. 1010 10 data word in transmit FIFO. 1011 11 data word in transmit FIFO. 1100 12 data word in transmit FIFO. 1101 13 data word in transmit FIFO. 1110 14 data word in transmit FIFO. 1111 15 data word in transmit FIFO.</p>
7–4 RFWM0	<p>Receive FIFO Full WaterMark 0.</p> <p>These bits control the threshold at which the RFF0 flag will be set. The RFF0 flag is set whenever the data level in Rx FIFO 0 reaches the selected threshold.</p> <p>0000 Reserved 0001 RFF set when at least one data word have been written to the Receive FIFO Set when RxFIFO = 1,2.....15 data words</p>

Table continues on the next page...

I2Sx_FCSR field descriptions (continued)

Field	Description
	<p>0010 RFF set when more than or equal to 2 data word have been written to the Receive FIFO. Set when RxFIFO = 2,3.....15 data words</p> <p>0011 RFF set when more than or equal to 3 data word have been written to the Receive FIFO. Set when RxFIFO = 3,4.....15 data words</p> <p>0100 RFF set when more than or equal to 4 data word have been written to the Receive FIFO. Set when RxFIFO = 4,5.....15 data words</p> <p>0101 RFF set when more than or equal to 5 data word have been written to the Receive FIFO. Set when RxFIFO = 5,6.....15 data words</p> <p>0110 RFF set when more than or equal to 6 data word have been written to the Receive. Set when RxFIFO = 6,7.....15 data words</p> <p>0111 RFF set when more than or equal to 7 data word have been written to the Receive FIFO. Set when RxFIFO = 7,8.....15 data words</p> <p>1000 RFF set when more than or equal to 8 data word have been written to the Receive FIFO. Set when RxFIFO = 8,9.....15 data words</p> <p>1001 RFF set when more than or equal to 9 data word have been written to the Receive FIFO. Set when RxFIFO = 9,10.....15 data words</p> <p>1010 RFF set when more than or equal to 10 data word have been written to the Receive FIFO. Set when RxFIFO = 10,11.....15 data words</p> <p>1011 RFF set when more than or equal to 11 data word have been written to the Receive FIFO. Set when RxFIFO = 11,12.....15 data words</p> <p>1100 RFF set when more than or equal to 12 data word have been written to the Receive FIFO. Set when RxFIFO = 12,13.....15 data words</p> <p>1101 RFF set when more than or equal to 13 data word have been written to the Receive FIFO. Set when RxFIFO = 13,14,15data words</p> <p>1110 RFF set when more than or equal to 14 data word have been written to the Receive FIFO. Set when RxFIFO = 14,15 data words</p> <p>1111 RFF set when 15 data word have been written to the Receive FIFO (default). Set when RxFIFO = 15 data words</p>
<p>3-0 TFWM0</p>	<p>Transmit FIFO Empty WaterMark 0.</p> <p>These bits control the threshold at which the TFE0 flag will be set. The TFE0 flag is set whenever the empty slots in Tx FIFO exceed or are equal to the selected threshold.</p> <p>0000 Reserved</p> <p>0001 TFE set when there are more than or equal to 1 empty slots in Transmit FIFO. (default) Transmit FIFO empty is set when TxFIFO ≤ 14 data.</p> <p>0010 TFE set when there are more than or equal to 2 empty slots in Transmit FIFO. (default) Transmit FIFO empty is set when TxFIFO ≤ 13 data.</p> <p>0011 TFE set when there are more than or equal to 3 empty slots in Transmit FIFO. (default) Transmit FIFO empty is set when TxFIFO ≤ 12 data.</p> <p>0100 TFE set when there are more than or equal to 4 empty slots in Transmit FIFO. (default) Transmit FIFO empty is set when TxFIFO ≤ 11 data.</p> <p>0101 TFE set when there are more than or equal to 5 empty slots in Transmit FIFO. (default) Transmit FIFO empty is set when TxFIFO ≤ 10 data.</p> <p>0110 TFE set when there are more than or equal to 6 empty slots in Transmit FIFO. (default) Transmit FIFO empty is set when TxFIFO ≤ 9 data.</p> <p>0111 TFE set when there are more than or equal to 7 empty slots in Transmit FIFO. (default) Transmit FIFO empty is set when TxFIFO ≤ 8 data.</p> <p>1000 TFE set when there are more than or equal to 8 empty slots in Transmit FIFO. (default) Transmit FIFO empty is set when TxFIFO ≤ 7 data.</p>

Table continues on the next page...

I2Sx_FCSR field descriptions (continued)

Field	Description
1001	TFE set when there are more than or equal to 9 empty slots in Transmit FIFO. (default) Transmit FIFO empty is set when TxFIFO ≤ 6 data.
1010	TFE set when there are more than or equal to 10 empty slots in Transmit FIFO. (default) Transmit FIFO empty is set when TxFIFO ≤ 5 data.
1011	TFE set when there are more than or equal to 11 empty slots in Transmit FIFO. (default) Transmit FIFO empty is set when TxFIFO ≤ 4 data.
1100	TFE set when there are more than or equal to 12 empty slots in Transmit FIFO. (default) Transmit FIFO empty is set when TxFIFO ≤ 3 data.
1101	TFE set when there are more than or equal to 13 empty slots in Transmit FIFO. (default) Transmit FIFO empty is set when TxFIFO ≤ 2 data.
1110	TFE set when there are more than or equal to 14 empty slots in Transmit FIFO. (default) Transmit FIFO empty is set when TxFIFO ≤ 1 data.
1000	TFE set when there are more than or equal to 15 empty slots in Transmit FIFO. (default) Transmit FIFO empty is set when TxFIFO ≤ 0 data.

49.3.13 I²S AC97 Control Register (I2Sx_ACNT)

Addresses: I2S0_ACNT is 4002_F000h base + 38h offset = 4002_F038h

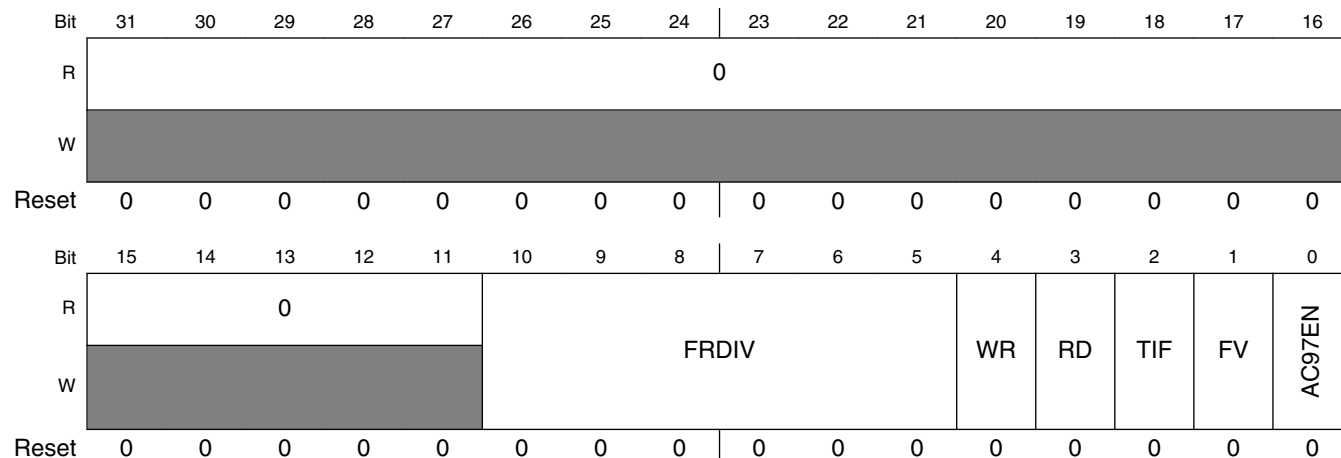

I2Sx_ACNT field descriptions

Field	Description
31–11 Reserved	This read-only field is reserved and always has the value zero.
10–5 FRDIV	Frame Rate Divider. These bits control the frequency of AC97 data transmission/reception. They are programmed with the number of frames for which the I ² S should be idle, after operating in one frame. Through these bits, AC97 frequency of operation, from 48 KHz (000000) to 1 KHz (101111) can be achieved. Sample Value: 001010 (10 Decimal) = I ² S will operate once every 11 frames
4 WR	Write Command.

Table continues on the next page...

I2Sx_ACNT field descriptions (continued)

Field	Description
	<p>This bit specifies whether the next frame will carry an AC97 Write Command or not. The programmer should take care that only one of the bits (WR or RD) is set at a time. When this bit is set, the corresponding tag bits (corresponding to Command Address and Command Data slots of the next Tx frame) are automatically set. This bit is automatically cleared by the I²S after completing transmission of a frame.</p> <p>0 Next frame will not have a Write Command. 1 Next frame will have a Write Command.</p>
3 RD	<p>Read Command.</p> <p>This bit specifies whether the next frame will carry an AC97 Read Command or not. The programmer should take care that only one of the bits (WR or RD) is set at a time. When this bit is set, the corresponding tag bit (corresponding to Command Address slot of the next Tx frame) is automatically set. This bit is automatically cleared by the I²S after completing transmission of a frame.</p> <p>0 Next frame will not have a Read Command. 1 Next frame will have a Read Command.</p>
2 TIF	<p>Tag in FIFO.</p> <p>This bit controls the destination of the information received in AC97 tag slot (Slot #0).</p> <p>0 Tag info stored in ATAG register. 1 Tag info stored in ATAG register and Rx FIFO 0.</p>
1 FV	<p>Fixed/Variable Operation.</p> <p>This bit selects whether the I²S is in AC97 Fixed mode or AC97 Variable mode.</p> <p>0 AC97 Fixed Mode 1 AC97 Variable Mode.</p>
0 AC97EN	<p>AC97 Mode Enable.</p> <p>This bit is used to enable I²S AC97 operation.</p> <p>0 AC97 mode disabled. 1 I²S in AC97 mode.</p>

49.3.14 I²S AC97 Command Address Register (I2Sx_ACADD)

Addresses: I2S0_ACADD is 4002_F000h base + 3Ch offset = 4002_F03Ch

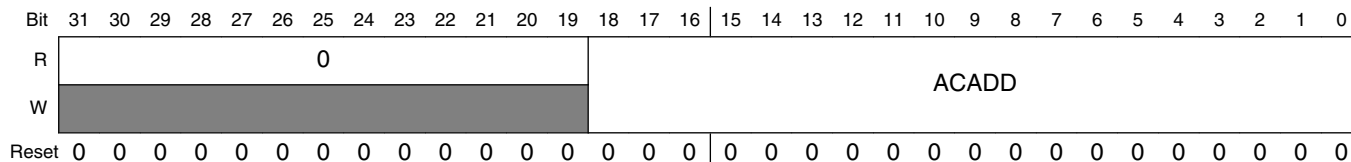

I2Sx_ACADD field descriptions

Field	Description
31–19 Reserved	This read-only field is reserved and always has the value zero.
18–0 ACADD	AC97 Command Address. These bits store the Command Address Slot information (bit 19 of the slot is sent in accordance with the Read and Write Command bits in ACNT register). These bits can be updated by a direct write from the Core. They are also updated with the information received in the incoming Command Address Slot. If the contents of these bits change due to an update, the CMDAU bit in ISR is set.

49.3.15 I²S AC97 Command Data Register (I2Sx_ACDAT)

Addresses: I2S0_ACDAT is 4002_F000h base + 40h offset = 4002_F040h

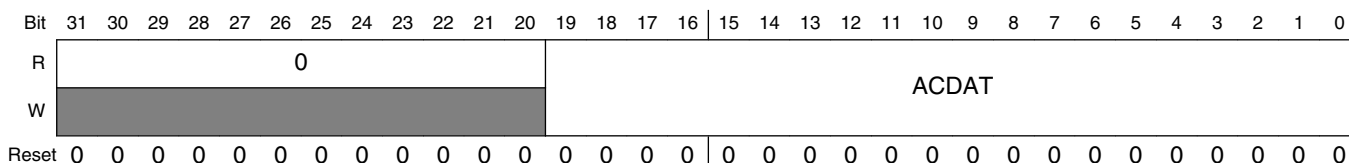

I2Sx_ACDAT field descriptions

Field	Description
31–20 Reserved	This read-only field is reserved and always has the value zero.
19–0 ACDAT	AC97 Command Data. The outgoing Command Data Slot carries the information contained in these bits. These bits can be updated by a direct write from the Core. They are also updated with the information received in the incoming Command Data Slot. If the contents of these bits change due to an update, the CMDDU bit in ISR is set. These bits are transmitted only during AC97 Write Command. During AC97 Read Command, 0x000000 is transmitted in time slot #2.

49.3.16 I²S AC97 Tag Register (I2Sx_ATAG)

Addresses: I2S0_ATAG is 4002_F000h base + 44h offset = 4002_F044h

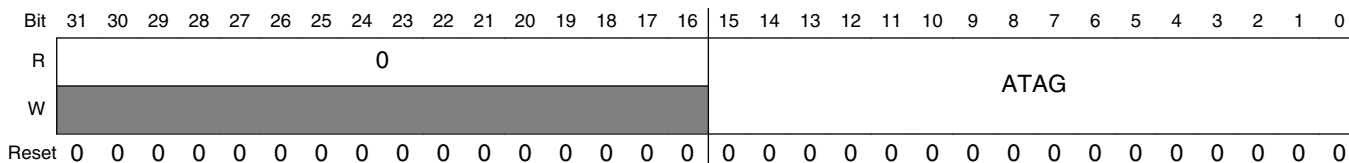

I2Sx_ATAG field descriptions

Field	Description
31–16 Reserved	This read-only field is reserved and always has the value zero.
15–0 ATAG	AC97 Tag Value. Writing to this register (by the Core) sets the value of the Tx-Tag in AC97 fixed mode of operation. On a read, the Core gets the Rx-Tag Value received (in the last frame) from the Codec. If TIF bit in ACNT register is set, the TAG value is also stored in Rx-FIFO in addition to ATAG register. When the received Tag value changes, the RXT bit in ISR register is set. Bits ATAG[1:0] convey the Codec -ID. In current implementation only Primary Codecs are supported. Thus writing value 2'b00 to this field is mandatory.

49.3.17 I²S Transmit Time Slot Mask Register (I2Sx_TMSK)

Addresses: I2S0_TMSK is 4002_F000h base + 48h offset = 4002_F048h

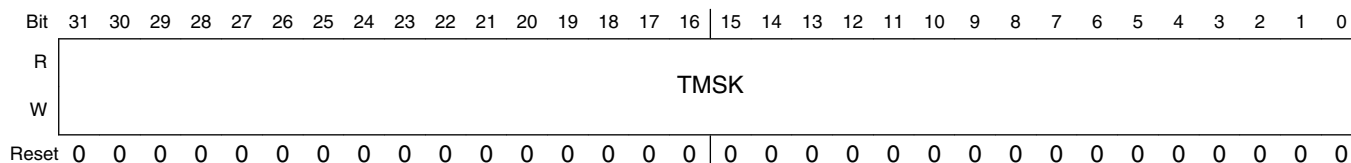

I2Sx_TMSK field descriptions

Field	Description
31–0 TMSK	Transmit Mask. These bits indicate which slot has been masked in the current frame. The Core can write to this register to control the time slots in which the I ² S transmits data. Each bit has info corresponding to the respective time slot in the frame. Transmit mask bits should not be used in I2S Slave mode of operation. TMSK register value must be set before enabling Transmission. 0 Valid Time Slot. 1 Time Slot masked (no data transmitted in this time slot).

49.3.18 I²S Receive Time Slot Mask Register (I2Sx_RMSK)

Addresses: I2S0_RMSK is 4002_F000h base + 4Ch offset = 4002_F04Ch

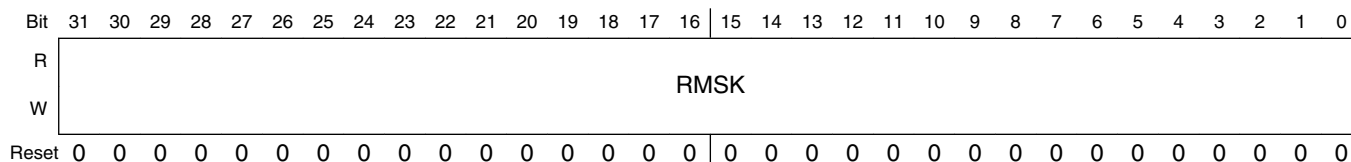

I2Sx_RMSK field descriptions

Field	Description
31–0 RMSK	<p>Receive Mask.</p> <p>These bits indicate which slot has been masked in the current frame. The Core can write to this register to control the time slots in which the I²S receives data. Each bit has info corresponding to the respective time slot in the frame. RMSK register value must be set before enabling Receiver. Receive mask bits should not be used in I2S Slave mode of operation.</p> <p>0 Valid Time Slot. 1 Time Slot masked (no data received in this time slot).</p>

49.3.19 I²S AC97 Channel Status Register (I2Sx_ACCST)

Addresses: I2S0_ACCST is 4002_F000h base + 50h offset = 4002_F050h

Bit	31	30	29	28	27	26	25	24	23	22	21	20	19	18	17	16	15	14	13	12	11	10	9	8	7	6	5	4	3	2	1	0
R	0																ACCST															
W	0																0															
Reset	0	0	0	0	0	0	0	0	0	0	0	0	0	0	0	0	0	0	0	0	0	0	0	0	0	0	0	0	0	0	0	0

I2Sx_ACCST field descriptions

Field	Description
31–10 Reserved	This read-only field is reserved and always has the value zero.
9–0 ACCST	<p>AC97 Channel Status.</p> <p>These bits indicate which data slot has been enabled in AC97 variable mode operation. This register is updated in case the core enables/disables a channel through a write to ACCEN/ACCDIS register or the external codec enables a channel by sending a `1' in the corresponding SLOTREQ bit. Bit [0] corresponds to the first data slot in an AC97 frame (Slot #3) and Bit [9] corresponds to the tenth data slot (slot #12). The contents of this register only have relevance while the I²S is operating in AC97 variable mode. Writes to this register result in an error response on the IP interface.</p> <p>0 Data channel disabled. 1 Data channel enabled.</p>

49.3.20 I²S AC97 Channel Enable Register (I2Sx_ACCEN)

Addresses: I2S0_ACCEN is 4002_F000h base + 54h offset = 4002_F054h

Bit	31	30	29	28	27	26	25	24	23	22	21	20	19	18	17	16	15	14	13	12	11	10	9	8	7	6	5	4	3	2	1	0
R	0																0															
W	0																ACCEN															
Reset	0	0	0	0	0	0	0	0	0	0	0	0	0	0	0	0	0	0	0	0	0	0	0	0	0	0	0	0	0	0	0	0

I2Sx_ACCEN field descriptions

Field	Description
31–10 Reserved	This read-only field is reserved and always has the value zero.
9–0 ACCEN	<p>AC97 Channel Enable.</p> <p>The Core writes a `1' to these bits to enable an AC97 data channel. Writing a `0' has no effect. Bit [0] corresponds to the first data slot in an AC97 frame (Slot #3) and Bit [9] corresponds to the tenth data slot (slot #12). Writes to these bits only have effect in the AC97 Variable mode of operation. These bits are always read as `0' by the Core.</p> <p>0 Write has no effect. 1 Write enables the corresponding data channel.</p>

49.3.21 I²S AC97 Channel Disable Register (I2Sx_ACCDIS)

Addresses: I2S0_ACCDIS is 4002_F000h base + 58h offset = 4002_F058h

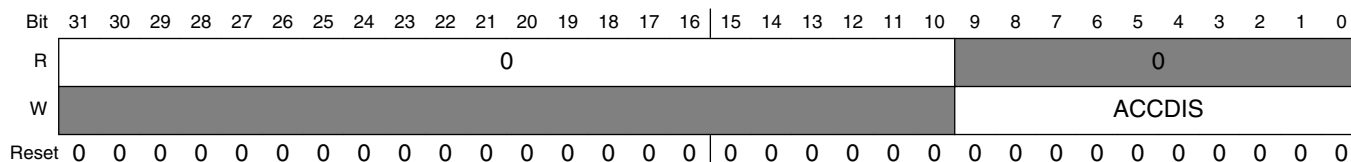

I2Sx_ACCDIS field descriptions

Field	Description
31–10 Reserved	This read-only field is reserved and always has the value zero.
9–0 ACCDIS	<p>AC97 Channel Disable.</p> <p>The Core writes a `1' to these bits to disable an AC97 data channel. Writing a `0' has no effect. Bit [0] corresponds to the first data slot in an AC97 frame (Slot #3) and Bit [9] corresponds to the tenth data slot (slot #12). Writes to these bits only have effect in the AC97 Variable mode of operation. These bits are always read as `0' by the Core.</p> <p>0 Write has no effect. 1 Write disables the corresponding data channel.</p>

49.4 Functional description

This section provides the functional details of the I²S module.

49.4.1 Detailed operating mode descriptions

The following sections provide detailed descriptions of the above modes.

49.4.1.1 Normal mode

Normal mode is the simplest mode of the I²S. It transfers data in one time slot per frame. A time slot is a unit of data and the RCCR[WL] bits define the number of bits in a time slot. In continuous clock mode, a frame sync occurs at the beginning of each frame. The following factors determine the length of the frame:

- Period of the serial bit clock (TCCR[DIV2], TCCR[PSR], TCCR[PM] bits for internal clock or the frequency of the external clock on the STCK port)
- Number of bits per time slot (RCCR[WL] bits)
- Number of time slots per frame (TCCR[DC] bits)

If normal mode is configured with more than one time slot per frame, data transfers only in the first time slot of the frame. No data transfers in subsequent time slots. In normal mode, TCCR[DC] values corresponding to more than a single time slot in a frame only result in lengthening the frame.

49.4.1.1.1 Normal mode transmit

Conditions for data transmission from the I²S in normal mode are:

1. I²S enabled (CR[I2SEN] = 1)
2. Enable FIFO and configure transmit and receive watermark if the FIFO is used
3. Write data to transmit data register (TX)
4. Transmitter enabled (CR[TE] = 1)
5. Frame sync active (for continuous clock case)
6. Bit clock begins (for gated clock case)

When the above conditions occur in normal mode, the next data word transfers into the transmit shift register (TXSR) from the transmit data register 0 (TX0), or from the transmit FIFO 0 register, if enabled.

- In continuous clock mode, the data word is transmitted on arrival of frame-sync preceded by clocks.

- In gated-external mode, the data word is transmitted on the external clock.
- In gated-internal mode, the data word is transmitted whenever data is available in the transmit FIFO.

If transmit FIFO 0 is not enabled and the transmit data register empty enable (IER[TDE0EN]) and transmit interrupt enable (IER[TIE]) bits are set, transmit interrupt 0 occurs when the word in I²S_TX0 is shifted to transmit shift (TXSR) register.

If transmit FIFO 0 is enabled and the transmit FIFO full enable (IER[TFF0EN]) and transmit interrupt enable (IER[TIE]) bits are set, transmit interrupt 0 occurs when the number of empty slots in transmit FIFO 0 are equal to or exceed the selected threshold value (transmit FIFO 0 watermark (FCSR[TFWM0]). If transmit FIFO 0 is enabled and filled with data, 15 data words can be transferred before the core must write new data to the TX0 register.

The STXD port is disabled except during the data transmission period. For a continuous clock, the optional frame sync output and clock outputs are not disabled, even if the receiver and transmitter are disabled.

49.4.1.1.2 Normal mode receive

The conditions for data reception from the I²S are:

1. I²S enabled (CR[I2SEN] = 1)
2. Enable receive FIFO (optional)
3. Receiver enabled (CR[RE] = 1)
4. Frame sync active (for continuous clock case)
5. Bit clock begins (for gated clock case)

With the above conditions in normal mode with a continuous clock, each time the frame sync signal is generated (or detected) a data word is clocked in. With the above conditions and a gated clock, each time the clock begins, a data word is clocked in.

If receive FIFO 0 is not enabled and receive interrupt enable (IER[RIE]) and received data 0 ready enable (IER[RDR0EN]) bits are set, receive interrupt 0 occurs when received data word is transferred from the receive shift register (RXSR) to the receive data register 0 (RX0), thus setting the receive data ready 0 (RDR0) flag.

If receive FIFO 0 is enabled and receive interrupt enable (IER[RXIE]) and received FIFO 0 full enable (IER[RDR0EN]) bits are set, receive interrupt 0 occurs when the received data word is transferred to the receive FIFO 0 and receive FIFO 0 reaches the selected threshold. This results in receive FIFO full 0 (RFF0) flag to set.

The core has to read the data from the receive data register 0 (RX0) (if receive FIFO 0 is disabled) before a new data word is transferred from the receive shift register (RXSR). Otherwise, the receive overrun error 0 (IER[ROE0EN]) bit is set. If receive FIFO 0 is enabled, the receive overrun error 0 (ROE0) bit sets when the receive FIFO 0 data level reaches the selected threshold and a new data word is ready to transfer to the receive FIFO 0.

The following figure shows transmitter and receiver timing for an 8-bit word in the first time slot in normal mode and continuous clock with a late word length frame sync. The transmit data register is loaded with the data to be transmitted. On arrival of the clock, this data is transferred to the transmit shift register which is transmitted on arrival of the frame-sync on the STXD output. Simultaneously, the receive shift register shifts in the received data available on the SRXD input. At the end of the time slot, this data is transferred to the receive data register.

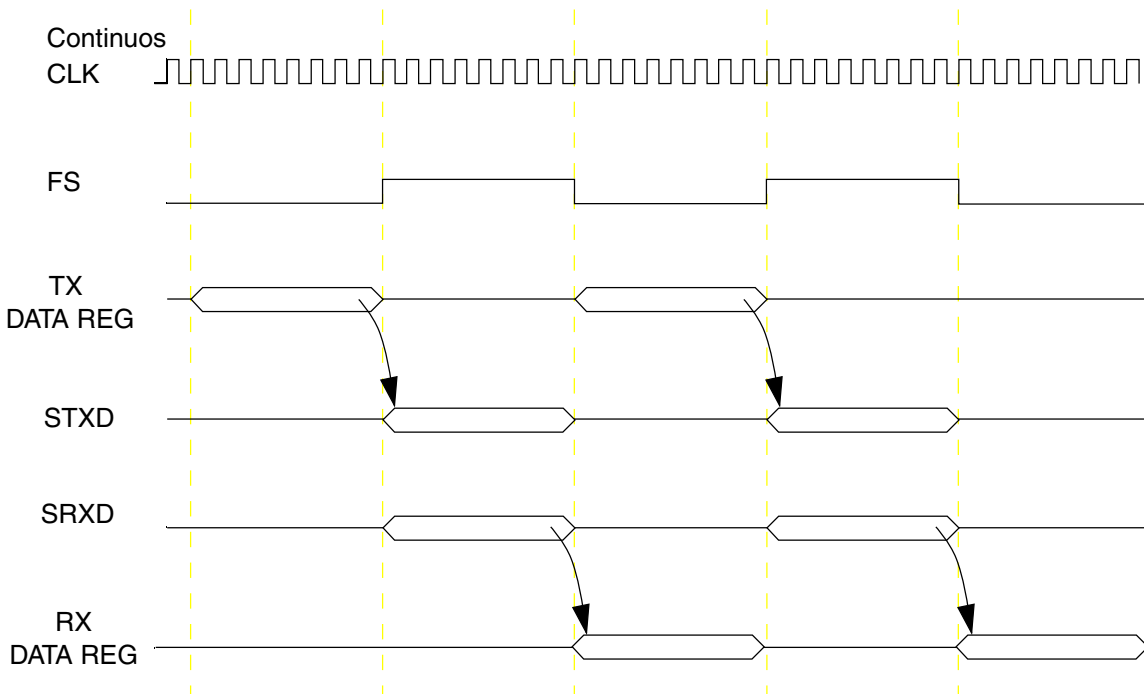

Figure 49-46. Normal mode timing - continuous clock

The following figure shows a similar case for internal (I²S generates clock) gated clock mode.

Note

A pull-down resistor is required in the gated clock mode, because the clock port is disabled between transmissions.

The Tx data register is loaded with the data to be transmitted. On arrival of the clock, this data is transferred to the transmit shift register which gets transmitted on the STXD output. Simultaneously, the receive shift register shifts in the received data available on the SRXD input and at the end of the time slot, this data is transferred to the Rx data register. In internal gated clock mode, the Tx data line and clock output port are put in the high-impedance state at the end of transmission of the last bit (at the completion of the complete clock cycle). Whereas, in external gated clock mode, the Tx data line is tri-stated at the last inactive edge of the incoming bit clock (during the last bit in a data word).

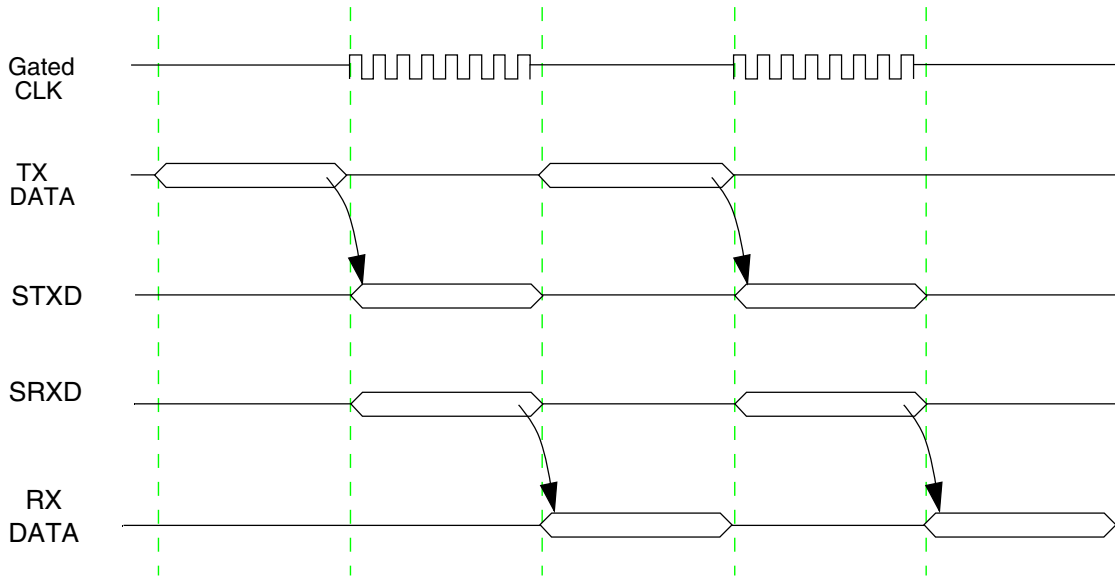

Figure 49-47. Normal mode timing - internal gated clock

The following figure shows a case for external (I²S receives clock) gated clock mode

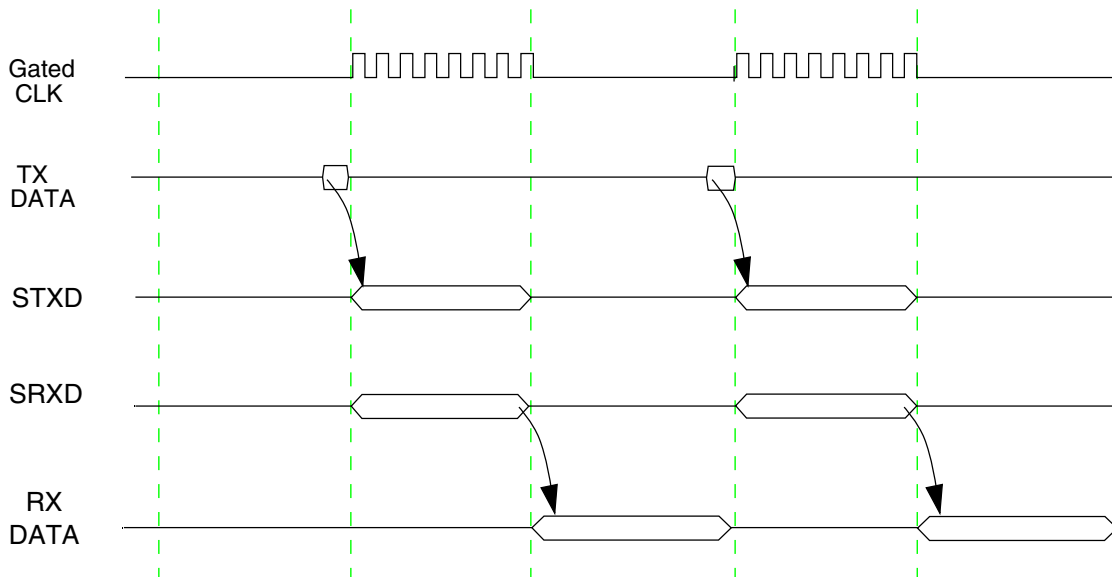

Figure 49-48. Normal mode timing - external gated clock

49.4.1.2 Network mode

Network mode creates a time division multiplexed (TDM) network, such as a TDM CODEC network or a network of DSPs. In continuous clock mode, a frame sync occurs at the beginning of each frame. In this mode, the frame is divided into more than one time slot. During each time slot, one data word can be transferred. Each time slot is then assigned to an appropriate codec or DSP on the network. The processor can be a master device that controls its own private network, or a slave device that is connected to an existing TDM network and occupies a few time slots.

The frame sync signal indicates the beginning of a new data frame. Each data frame is divided into time slots and transmission and/or reception of one data word can occur in each time slot (rather than in just the frame sync time slot as in normal mode).

The frame rate dividers, controlled by the DC bits, select two to thirty-two time slots per frame. The length of the frame is determined by:

- Period of the serial bit clock (PSR, PM bits for internal clock, or the frequency of the external clock on the STCK port)
- Number of bits per sample (WL bits)
- Number of time slots per frame (DC bits)

In network mode, data can be transmitted in any time slot. The distinction of the network mode is that each time slot is identified with respect to the frame sync (data word time). This time slot identification allows the option of transmitting data during the time slot by

writing to the TX registers or ignoring the time slot as determined by TMSK register bits. The receiver is treated in the same manner and received data is only transferred to the receive data register/FIFO if the corresponding time slot is enabled through RMSK.

By using the TMSK and RMSK registers, software only has to service the I²S during valid time slots. This eliminates any overhead associated with unused time slots.

In the two-channel mode, the second set of transmit and receive FIFOs and data registers create two separate channels. These channels are completely independent with their own set of interrupts and DMA requests, which are identical to the ones available for the default channel. In this mode, data is transmitted/received in enabled time slots alternately from/to FIFO 0 and FIFO 1, starting from FIFO 0. The first data word is taken from FIFO 0 and transmitted in the first enabled time slot and subsequently, data is loaded from FIFO 1 and FIFO 0 alternately and transmitted. Similarly, the first received data is sent to FIFO 0 and subsequent data is sent to FIFO 1 and FIFO 0 alternately. Time slots are selected through the transmit and receive time slot mask registers (TMSK and RMSK). For using this mode of operation, the CR[TCHEN] bit must be set.

49.4.1.2.1 Network mode transmit

The transmit portion of I²S is enabled when the CR[I2SEN and TE] bits are set. However, for continuous clock, when the CR[TE] bit is set, the transmitter is enabled only after detection of a new frame sync (transmission starts from the next frame boundary).

Normal start-up sequence for transmission:

1. Enable network mode
2. Enable I²S
3. Write the data to be transmitted to the TX register. This clears the ISR[TDE] flag
4. Set the CR[TE] bit to enable the transmitter on the next frame boundary (for continuous clock)
5. Enable transmit interrupts

Alternatively, the user may decide not to transmit in a time slot by configuring the TMSK[STMSK]. The ISR[TDE] flag is cleared as data is shifted from TX register to TXSR, but the STXD port remains disabled during the time slots. When the next frame sync is detected or generated (continuous clock), the data word in TXSR and is shifted out (transmitted). When the TX register is empty, the ISR[TDE] bit is set, which causes a transmitter interrupt (in case the FIFO is disabled) to be sent if the TIE bit is set. Software can poll the ISR[TDE] bit or use interrupts to reload the TX register with new data for the

next time slot. Failing to reload the TX register before the TXSR is finished shifting (empty) causes a transmitter underrun and the TUE error bit is set. In case the FIFO is enabled, the ISR[TFE] flag is set in accordance with the watermark setting and this flag causes the transmitter interrupt to occur.

Clearing the TE bit disables the transmitter after completion of transmission of the current frame. Setting the TE bit enables transmission from the next frame. During that time the STXD port is disabled. The TE bit should be cleared after the ISR[TDE] bit is set to ensure that all pending data is transmitted.

To summarize, the network mode transmitter generates interrupts every enabled time slot (when FIFO is disabled) and requires the processor to respond to each enabled time slot. These responses may be:

- Write data in data register to enable transmission in the next time slot.
- Configure the time slot register to disable transmission in the next time slot (unless time slot is already masked by TMSK[STMSK] register bit).
- Do nothing—transmit underrun occurs at the beginning of the next time slot and the previous data is re-transmitted.

In two-channel mode, both channels (data registers, FIFOs, interrupts, and DMA requests) operate in the same manner, as described above. The only difference is interrupts related to the second channel are generated only if this mode of operation is selected (ISR[TDE1] is low by default).

49.4.1.2.2 Network mode receive

The receiver portion of the I²S is enabled when the CR[I2SEN and RE] bits are set. However, the receive enable only takes place during that time slot if RE is enabled before the second to last bit of the word. If the RE bit is cleared, the receiver is disabled at the end of the current frame. The I²S module is capable of finding the start of the next frame automatically. When the word is completely received, it is transferred to the RX register, which sets the ISR[RDR] bit. This causes a receive interrupt to occur if the receiver interrupt is enabled (IER[RIE] is set) and receive data ready is enabled (IER[RDR0EN] and IER[RDR1EN] is set). The second data word (second time slot in the frame) begins shifting in immediately after the transfer of the first data word to the RX register. The processor has to read the data from the receive data register (which clears ISR[RDR]) before the second data word is completely received (ready to transfer to RX data register) or a receive overrun error occurs (the ISR[ROE] bit is set).

An interrupt can occur after the reception of each enabled data word or the user can poll the ISR[RDR] flag. The response can be:

- Read RX and use the data.
- Read RX and ignore the data.
- Do nothing—the receiver overrun exception occurs at the end of the current time slot.

Note

For a continuous clock, the optional frame sync output and clock output signals are not affected, even if the transmitter or receiver is disabled. TE and RE do not disable the bit clock or the frame sync generation. To disable the bit clock and the frame sync generation, the CR[I2SEN] bit can be cleared, or CR[TFRCLKDIS]/CR[RFCLKDIS] bits can be set, or the port control logic external to the I²S can be reconfigured.

In two-channel mode, both channels (data registers, FIFOs, interrupts and DMA requests) operate in the same manner, as described above. The only difference is second channel interrupts are generated only in this mode of operation.

The following figure shows the transmitter and receiver timing for an 8-bit word with continuous clock, FIFO disabled, three words per frame sync in network mode.

Note

The transmitter repeats the value 0x5E because of an underrun condition

For the receive section, data received on the SRXD pin is transferred to the Rx Data register at the end of each time slot. If the FIFO is disabled, the ISR[RDR] flag sets and causes a receiver interrupt if the CR[RE], IER[RIE], and IER[RDREN] bits are set. If the FIFO is enabled, then the ISR[RFF] flag generates interrupts (this flag is set in accordance with the watermark settings). In this example all time slots are enabled. The receive data ready flag is set after reception of the first data (0x55). Because the flag is not cleared (Rx data register is not read), the receive overrun error (ROE) flag is set on reception of the next data (0x5E). The ISR[ROE] flag is cleared by writing one to the corresponding interrupt status bit in I²S status register.

functional description

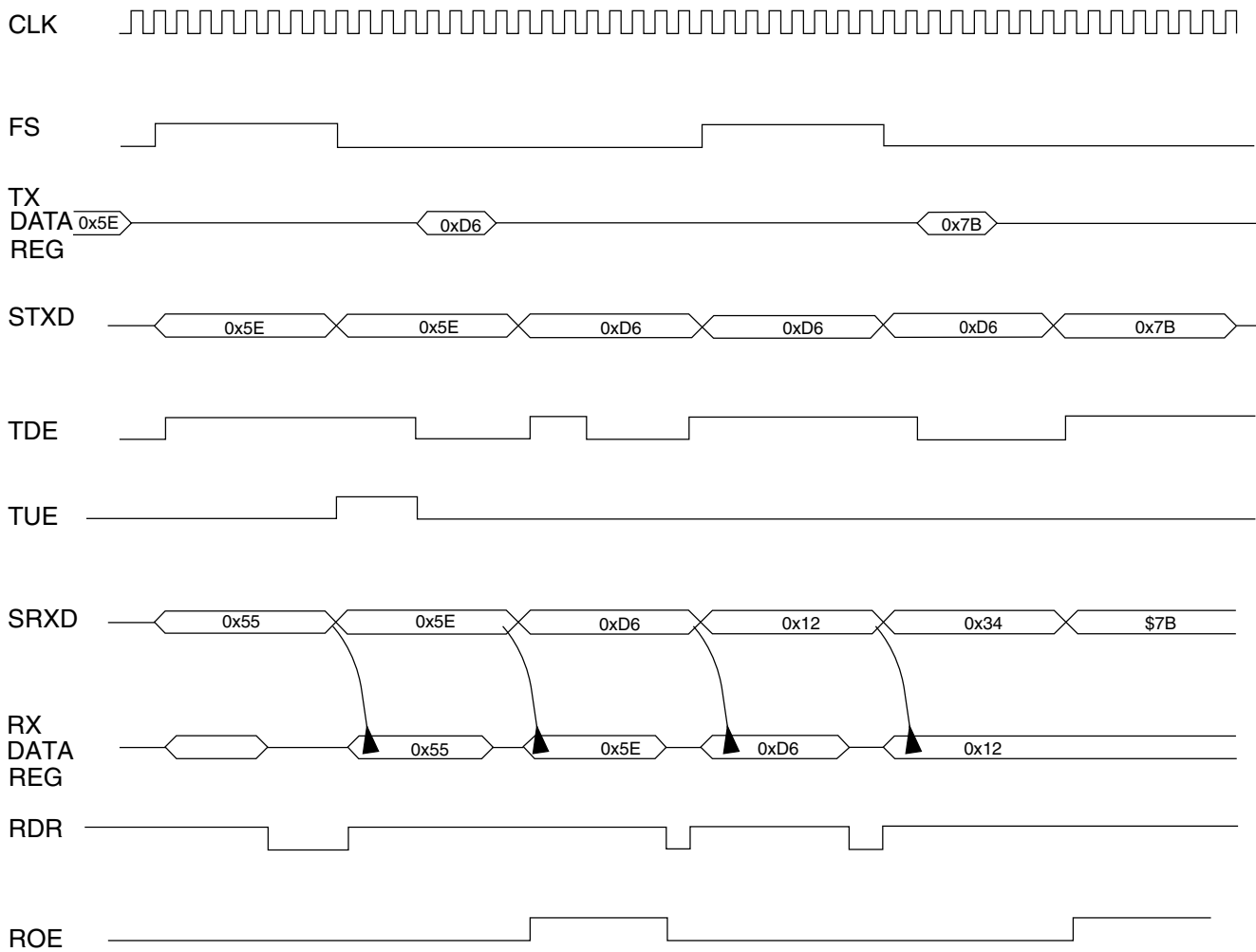

Note: Processor must write '1' to the corresponding TUE/ROE Interrupt status bit in ISR to clear TUE/ROE Interrupt

Figure 49-49. Network mode timing - continuous clock

49.4.1.3 Gated clock mode

Gated clock mode often connects to SPI-type interfaces on microcontroller units (MCUs) or external peripheral devices. In gated clock mode, the presence of the clock indicates that valid data is on the STXD or SRXD signals. For this reason, no frame sync is needed in this mode. After transmission of data completes, the clock is pulled to the inactive state. Gated clocks are allowed for the transmit and receive sections with either internal or external clock in normal mode. Gated clocks are not allowed in network mode. See [Table 49-3](#) for I²S configuration for gated-mode operation.

The clock operates when the CR[TE] bit and/or the CR[RE] bit are appropriately enabled. For the case of internally generated clock, all internal bit clocks, word clocks, and frame clocks continue to operate. When a valid time slot occurs (such as the first time slot in

normal mode), the internal bit clock is enabled onto the appropriate clock port. This allows data to be transferred out in periodic intervals in gated clock mode. With an external clock, the I²S module waits for a clock signal to be received. After the clock begins, valid data is shifted in. Ensure all RCCR[DC] bits are cleared when the module is used in gated mode. In gated mode the ISR[TFS], ISR[RFS], ISR[TLS], ISR[RLS], ISR[TRFC] and ISR[RFRC] bits are not generated.

For gated clock operated in external clock mode, proper clock signalling must apply to the I²S STCK for it to function properly. When TCR[TSCCKP] is cleared, CR[CLKIST] must be set. When TCR[TSCCKP] is set, CR[CLKIST] value must be cleared. If the I²S uses rising edge transition to clock data (TCR[TSCCKP] = 0) and the falling edge transition to latch data (RCR[RSCKP] = 0), the clock must be in an active low state when idle. If the I²S uses falling edge transition to clock data (TCR[TSCCKP] = 1) and the rising edge transition to latch data (RCR[RSCKP] = 1), the clock must be in a active high state when idle. The following diagrams illustrate the different edge clocking/latching.

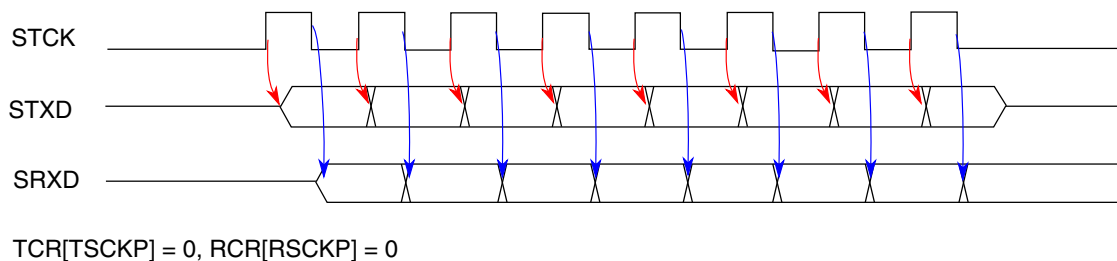

Figure 49-50. Internal gated mode timing - rising edge clocking/falling edge latching

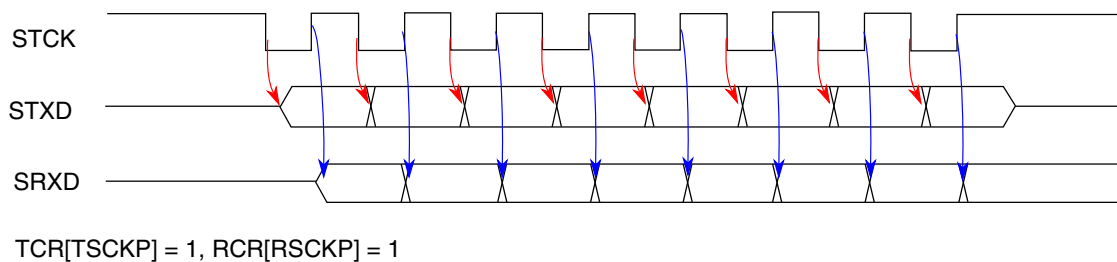

Figure 49-51. Internal gated mode timing - falling edge clocking/rising edge latching

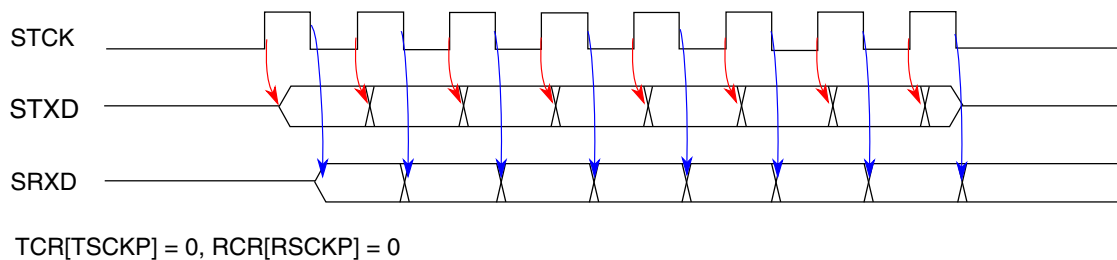
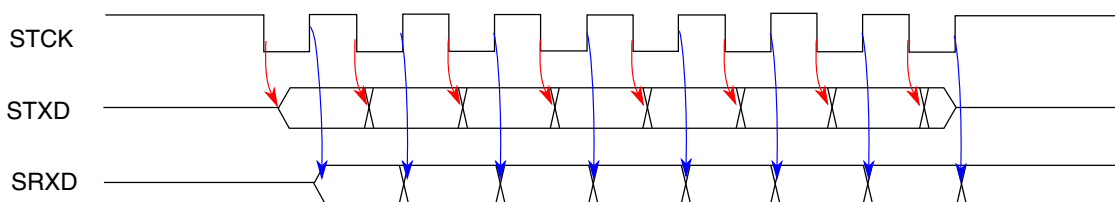

Figure 49-52. External gated mode timing - rising edge clocking/falling edge latching

functional description



TCR[TSCKP] = 1, RCR[RSCKP] = 1

Figure 49-53. External gated mode timing - falling edge clocking/rising edge latching

Note

- The bit clock signals must not have timing glitches. If a single glitch occurs, all ensuing transfers are out of synchronization.
- In external gated mode, even though the transmit data line is tri-stated at the last non-active edge of the bit clock, the round trip delay should sufficiently take care of hold time requirements at the external receiver.

49.4.1.4 I²S mode

The I²S is compliant to the Inter-IC Sound (I²S) bus specification from Philips Semiconductors (February 1986, Revised June 5, 1996). The following figure depicts basic I²S protocol timing.

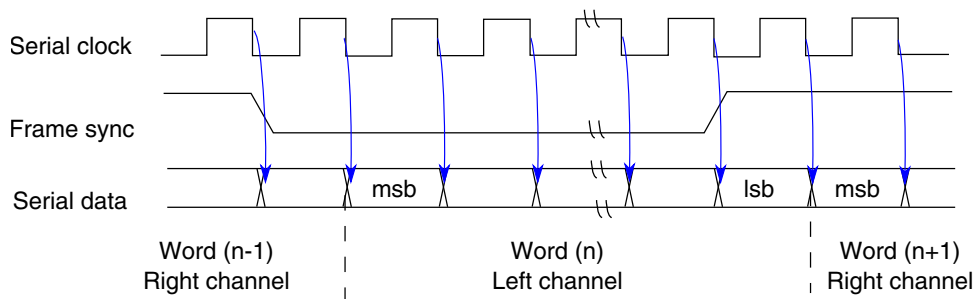

Figure 49-54. I²S mode timing - serial clock, frame sync and serial data

Select I²S mode using the options listed in the following table.

Table 49-50. I²S mode selection

CR[I2SMODE]	Mode type
00	Normal mode
01	I ² S master mode

Table continues on the next page...

Table 49-50. I²S mode selection (continued)

CR[I2SMODE]	Mode type
10	I ² S slave mode
11	Normal mode

In normal (non-I²S) mode operation, no register bits are forced to any particular state internally, and the user can program the I²S to work in any operating condition.

When I²S modes are entered (CR[I2SMODE] = 01 or 10), these settings are recommended:

- Synchronous mode (CR[SYN] = 1)
- Tx shift direction: msb transmitted first (TCR[TSHFD] = 0)
- Rx shift direction: msb received first (RCR[RSHFD] = 0)
- Tx data clocked at falling edge of the clock (TCR[TSCKP] = 1)
- Rx data latched at rising edge of the clock (RCR[RSCKP] = 1)
- Tx frame sync active low (TCR[TFSI] = 1)
- Rx frame sync active low (RCR[RFSI] = 1)
- Tx frame sync initiated one bit before data is transmitted (TCR[TEFS] = 1)
- Rx frame sync initiated one bit before data is received (RCR[REFS] = 1)
- Tx frame rate should be 2 (TCCR[DC] = 1)
- Rx frame rate should be 2 (RCCR[DC] = 1)

49.4.1.4.1 I²S master mode

In I²S master mode (CR[I2SMODE] = 01b), the following additional settings are recommended:

- Internal generated bit clock (TCR[TXDIR] = 1)
- Internal generated frame sync (TCR[TFDIR] = 1)

The processor automatically performs these settings in I²S master mode:

- Network mode is selected (CR[NET] = 1)
- Tx frame sync length set to one-word-long-frame (TCR[TFSL]=0)

functional description

- Rx frame sync length set to one-word-long-frame (RCR[RFSL]=0)
- Tx shifting w.r.t. bit 0 of TXSR (TCR[TXBIT0] = 1)
- Rx shifting w.r.t. bit 0 of RXSR (RCR[RXBIT0] = 1)

Set the TCCR[PM, PSR, DIV2, WL, DC] to configure the bit clock and frame sync.

The word length is fixed to 32 in I²S master mode and the RCCR[WL] bits determine the number of bits that contain valid data (out of the 32 transmitted/received bits in each channel).

49.4.1.4.2 I²S slave mode

In I²S slave mode (CR[I2SMODE] = 10b), the following additional settings are recommended:

- External generated bit clock (TCR[TXDIR] = 0)
- External generated frame sync (TCR[TFDIR] = 0)

The processor automatically performs these settings in I²S slave mode:

- Normal mode is selected (CR[NET] = 0)
- Tx frame sync length set to one-bit-long-frame (TCR[TFSL] = 1)
- Rx frame sync length set to one-bit-long-frame (RCR[RFSL] = 1)
- Tx shifting w.r.t. bit 0 of TXSR (TCR[TXBIT0] = 1)
- Rx shifting w.r.t. bit 0 of RXSR (RCR[RXBIT0] = 1)

Set the TCCR[WL, DC] bits to configure the data transmission.

The word length is variable in I²S slave mode and the RCCR[WL] bits determine the number of bits that contain valid data. The actual word length is determined by the external codec. The external I²S master sends a frame sync according to the I²S protocol (early, word wide, and active low). The I²S internally operates so each frame sync transition is the start of a new frame (the RCCR[WL] bits determine the number of bits to be transmitted/received). After one data word has been transferred, the I²S waits for the next frame sync transition to start operation in the next time slot. Transmit and receive mask bits should not be used in I²S slave mode.

49.4.1.5 AC97 mode

In AC97 mode, the I²S transmits a 16-bit tag slot at the start of a frame and the rest of the slots (in that frame) are all 20-bits wide. The same sequence is followed while receiving data. Refer to the AC97 specification for details regarding transmit and receive sequences and data formats.

Note

The Audio Codec specification released in 1997 [AC '97] defines the architecture and digital Interface, specifically designed for implementing audio and modem I/O functionality in personal computers. Companion specifications include the Modem Codec [MC '97], and the combined Audio/Modem Codec standard [AMC '97]. The current version of AC '97 was produced in 2002. The AC-97 specification defines a recommended 48-pin QFP IC package.

Since the I²S has only one RxDATA pin only one codec is supported. Secondary codecs are not supported.

When AC97 mode is enabled, the hardware internal overrides the following settings. The programmed register values are not changed by entering AC97 mode but they no longer apply to the module's operation. Writing to the programmed register fields updates their values. These updates can be seen by reading back the register fields. However, these settings do not take effect until AC97 mode is turned off.

The register bits within the bracket are equivalent settings:

- Synchronous mode is entered (CR[SYN] = 1)
- Network mode is selected (CR[NET] = 1)
- Tx shift direction is msb transmitted first (TCR[TSHFD] = 0)
- Rx shift direction is msb received first (RCR[RSHFD] = 0)
- Tx data is clocked at rising edge of the clock (TCR[TSCKP] = 0)
- Rx data is latched at falling edge of the clock (RCR[RSCKP] = 0)
- Tx frame sync is active high (TCR[TFSI] = 0)
- Rx frame sync is active high (RCR[RFSI] = 0)
- Tx frame sync length is one-word-long-frame (TCR[TFSL] = 0)
- Rx frame sync length is one-word-long-frame (RCR[RFSL] = 0)

functional description

- Tx frame sync initiated one bit before data is transmitted (TCR[TEFS] = 1)
- Rx frame sync initiated one bit before data is received (RCR[REFS] = 1)
- Tx shifting w.r.t. bit 0 of TXSR (TCR[TXBIT0] = 1)
- Rx shifting w.r.t. bit 0 of RXSR (RCR[RXBIT0] = 1)
- Tx FIFO is enabled (TCR[TFEN0] = 1)
- Rx FIFO is enabled (RCR[RFEN0] = 1)
- Internally-generated frame sync (TCR[TFDIR] = 1)
- Externally-generated bit clock (TCR[TXDIR] = 0)

Any alteration of these bits does not affect the operational conditions of the I²S unless AC97 mode is deselected. Hence, the only control bits that need to be set to configure the data transmission/reception are the TCCR[WL, DC] bits. In AC97 mode, the WL bits can only legally take the values corresponding to 16-bit (truncated data) or 20-bit time slots. If the WL bits are set to select 16-bit time slots while receiving, the I²S pads the transmit data (four least significant bits) with zeros and while receiving, the I²S stores only the 16 most significant bits in the Rx FIFO.

Follow the sequence for programming the I²S to work in AC97 mode:

1. Program the TCCR[WL] bits to a value corresponding to 16 or 20 bits. The WL bit setting is only for the data portion of the AC97 frame (slots #3 through #12). The tag slot (slot #0) is always 16 bits wide and the command address and command data slots (slots #1 and #2) are always 20 bits wide.
2. Select the number of time slots through the TCCR[DC] bits. For AC97 operation, the DC bits should be set to a value of 0xC, resulting in 13 time slots per frame.
3. Write data to be transmitted in Tx FIFO 0 (through Tx data register 0) and Tx FIFO 1 while using two-channel mode (CR[TCHEN] = 1).
4. Program the ACNT[FV, TIF, RD, WR, and FRDIV] bits
5. Update the contents of ACADD, ACDAT, and ATAG (for fixed mode only) registers
6. Enable AC97 mode (ACNT[AC97EN])

After the I²S starts transmitting and receiving data (after being configured in AC97 mode), the processor needs to service the interrupts when they are raised (updates to command address/data or tag registers, reading of received data, and writing more data for transmission). Further details regarding fixed and variable mode implementation appear in the following sections.

While using AC97 in two-channel mode ($CR[TCHEN] = 1$), it is recommended that the received tag is not stored in the Rx FIFO ($ACNT[TIF] = 0$). If you need to update the ATAG register and also issue a RD/WR command (in a single frame), it is recommended that the ATAG register is updated prior to issuing a RD/WR command.

49.4.1.5.1 AC97 fixed mode ($ACNT[FV] = 0$)

In fixed mode, I²S transmits in accordance with the AC97 frame rate divider bits ($ACNT[FRDIV]$) that decide the number of frames for which the I²S should be idle, after operating for one frame. The following shows the slot assignments in a valid transmit frame:

- Slot 0: The tag value (written by the user program)
- Slot 1: If RD/WR command, command address
- Slot 2: If WR command, command data
- Slot 3–12: Transmit FIFO data, depending on the valid slots indicated by the TAG value

While receiving, bit 15 of the tag slot is checked to see if the codec is ready. If this bit is set, the frame is received. The received tag provides the information about slots containing valid data. If the corresponding tag bit is valid, the command address (slot #1) and command data (slot #2) values are stored in the corresponding registers. The received data (slot #3–12) is then stored in the receive FIFO (for valid slots).

49.4.1.5.2 AC97 variable mode ($ACNT[FV] = 1$)

In variable mode, the transmit slots that should contain data in the current frame are determined by the SLOTRREQ bits received in the previous frame. While receiving, if the codec is ready, the frame is received and the SLOTRREQ bits are stored for scheduling transmission in the next frame.

The ACCST, ACCEN and ACCDIS registers helps determine which transmit slots are active. This information is used to ensure that I²S does not transmit data for powered-down/inactive channels.

49.4.2 I²S clocking

The I²S uses the following clocks:

- Bit clock — Serially clocks the data bits in and out of the I²S port. This clock is either generated internally or taken from external clock source (through the Tx/Rx clock ports).
- Word clock — Counts the number of data bits per word (8, 10, 12, 16, 18, 20, 22 or 24 bits). This clock is generated internally from the bit clock.
- Frame clock (frame sync) — Counts the number of words in a frame. This signal can be generated internally from the bit clock, or taken from external source (from the Tx/Rx frame sync ports).
- Master clock — In master mode, this is an integer multiple of frame clock. It is used in cases when I²S has to provide the clock.

Ensure that the bit clock frequency (internally generated by dividing the network clock or sourced from external device through Tx/Rx clock ports) is never greater than 1/5 of the peripheral clock frequency.

In normal mode, the bit clock, used to serially clock the data, is visible on the serial transmit clock (STCK) and serial receive clock (SRCK) ports. The word clock is an internal clock used to determine when transmission of an 8, 10, 12, 16, 18, 20, 22 or 24 bit word has completed. The word clock then clocks the frame clock, which counts the number of words in the frame. The frame clock can be viewed on the STFS and SRFS frame sync ports, because a frame sync generates after the correct number of words in the frame have passed. In master and synchronous mode, the SRCK port is used as serial oversampling clock (network clock) enabled by the CR[SYSCLKEN] bit. This serial system clock is an oversampling clock of the frame sync clock (STFS). In this mode, the word length (WL), prescaler range (PSR), prescaler modulus (PM), and frame rate (DC) selects the ratio of network clock to sampling clock, STFS. In I²S mode, the oversampling clock network clock is available on this port if the CR[SYSCLKEN] bit is set.

The following figure shows the relationship between the clocks and the dividers. The bit clock can be received from an I²S clock port or can be generated from the network clock through a divider, as shown in [Figure 49-56](#).

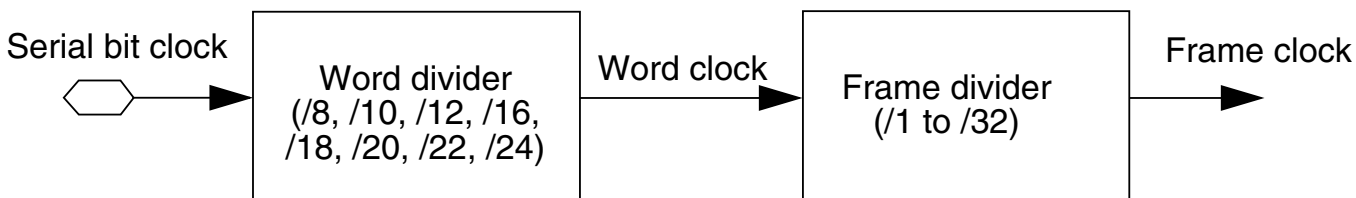

Figure 49-55. I²S clocking

49.4.2.1 I²S clock and frame sync generation

Data clock and frame sync signals can be generated internally, or can be obtained from external sources. If internally generated, the I²S clock generator is used to derive bit clock and frame sync signals from the network clock. The I²S clock generator consists of a selectable, fixed prescaler and a programmable prescaler for bit rate clock generation. In gated clock mode, the data clock is valid only when data is being transmitted. Otherwise the clock port is pulled to the inactive state. A programmable frame rate divider and a word length divider are used for frame rate sync signal generation.

The following figure shows a block diagram of the clock generator for the transmit section. The serial bit clock can be internal or external, depending on the TCR[TXDIR] bit. The receive section contains an equivalent clock generator circuit.

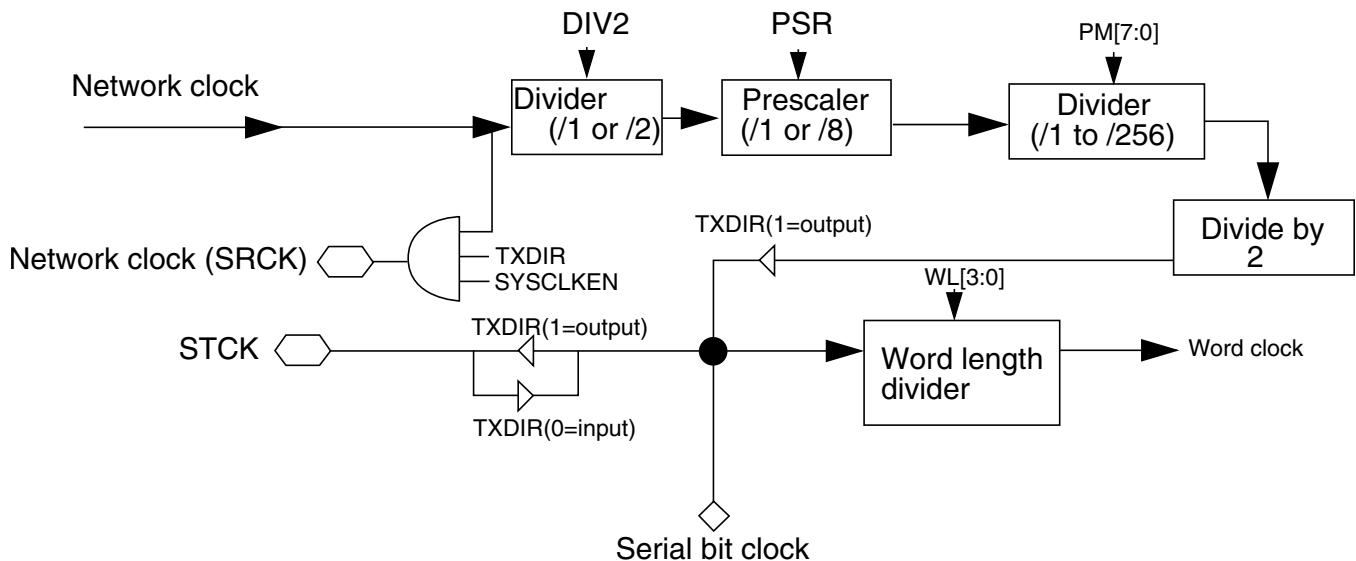

Figure 49-56. I²S transmit clock generator block diagram

The following figure shows the frame sync generator block for the transmit section. When internally generated, both receive and transmit frame sync are generated from the word clock and are defined by the frame rate divider (DC) bits and the word length (WL) bits of the TCCR. The receive section contains an equivalent circuit for the frame sync generator.

functional description

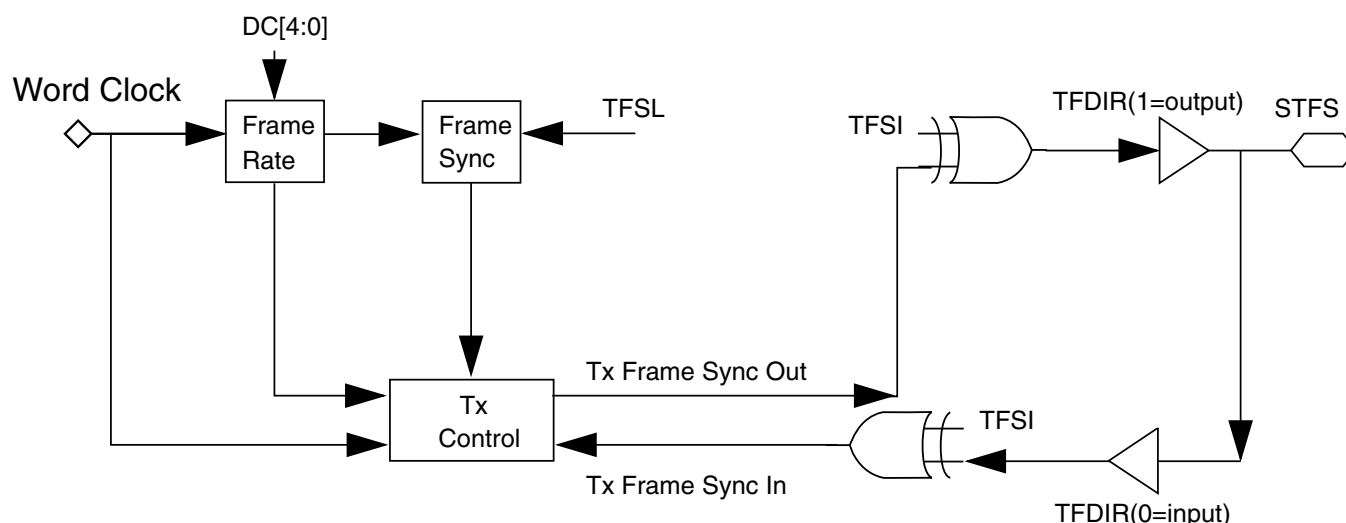

Figure 49-57. I²S transmit frame sync generator block diagram

49.4.2.2 DIV2, PSR and PM bits description

The bit clock frequency can be calculated from the I²S serial system clock using [id-73884](#).

Note

You must ensure that the bit-clock frequency must be 5 times the peripheral clock frequency. The oversampling clock frequency can go up to peripheral clock frequency. Bits DIV2, PSR and PM must not be cleared at the same time.

$$f_{\text{INT_BIT_CLK}} = \frac{\text{I}^2\text{Sserialsystemclock}}{(\text{DIV2}+1) \times (7 \times \text{PSR}+1) \times (\text{PM}+1) \times 2}$$

From this, the frame clock frequency can be calculated:

$$f_{\text{FS_CLK}} = \frac{f_{\text{INT_BIT_CLK}}}{(\text{DC}+1) \times (2 \times (\text{WL}+1))}$$

Figure 49-58. I²S bit clock equation

For example, if the I²S oversampling clock (network clock) is 12.288 MHz, in 8-bit word normal mode with DC = 1, PM = 47, PSR = 0, DIV2 = 1, a bit clock rate of 64 kHz is generated. Since the 8-bit word rate is equal to one (i.e. normal mode), the sampling rate (or frame sync rate) would then be 64/(1×8) = 8 kHz.

In the next example, the oversampling clock (network clock) clock is 11.2896 MHz. A 16-bit word network mode with TCCR[DC] = 1, TCCR[PM] = 3, TCCR[PSR] = 0, TCCR[DIV2] = 0, a bit clock rate of 1.4112 MHz is generated. Since the 16-bit word rate is equal to two, the sampling rate (or frame sync rate) would be $1.4112/(2 \times 16) = 44.1$ kHz.

The following table shows examples of programming the TCCR[PSR] and TCCR[PM] bits to generate various bit clock (STCK) frequencies.

Table 49-51. I²S bit clock and frame rate as a function of PSR, PM, and DIV2

Bits/ word	Words/ frame	MCLK/network clock freq (MHz)	TCCR					Bit clock (kHz) STCK	Frame rate (kHz)
			DIV2	PSR	PM	WL	DC		
16	1	12.288	0	0	47	7	0	128	8
16	2	12.288	0	0	23	7	1	256	8
16	4	12.288	0	0	11	7	3	512	8
16	1	12.288	0	0	31	7	0	192	12
16	2	12.288	0	0	15	7	1	384	12
16	4	12.288	0	0	7	7	3	768	12
16	1	12.288	0	0	23	7	0	256	16
16	2	12.288	0	0	11	7	1	512	16
16	4	12.288	0	0	5	7	3	1024	16
16	1	12.288	0	0	15	7	0	384	24
16	2	12.288	0	0	7	7	1	768	24
16	4	12.288	0	0	3	7	3	1536	24
16	1	12.288	0	0	11	7	0	512	32
16	2	12.288	0	0	5	7	1	1024	32
16	4	12.288	0	0	2	7	3	2048	32
16	1	12.288	0	0	15	7	0	768	48
16	2	12.288	0	0	3	7	1	1536	48
16	4	12.288	0	0	1	7	3	3072	48
16	1	11.2896	0	0	31	7	0	176.4	11.025
16	2	11.2896	0	0	15	7	1	352.8	11.025
16	4	11.2896	0	0	7	7	3	705.6	11.025
16	1	11.2896	0	0	15	7	0	352.8	22.05
16	2	11.2896	0	0	7	7	1	705.6	22.05
16	4	11.2896	0	0	3	7	3	1411.2	22.05

Table continues on the next page...

Table 49-51. I²S bit clock and frame rate as a function of PSR, PM, and DIV2 (continued)

Bits/ word	Words/ frame	MCLK/network clock freq (MHz)	TCCR					Bit clock (kHz) STCK	Frame rate (kHz)
			DIV2	PSR	PM	WL	DC		
16	1	11.2896	0	0	7	7	0	705.6	44.1
16	2	11.2896	0	0	3	7	1	1411.2	44.1
16	4	11.2896	0	0	1	7	3	2822.4	44.1

The table below shows an example of programming clock controller divider ratios to generate the appropriate oversampling clock and peripheral clock frequencies for various sampling rates. In these examples, the master mode is selected either by setting I²S master bit (CR[I2SMODE] = 01b) or individually programming the I²S in network, synchronous, transmit internal mode. (The table specifically illustrates the I²S mode frequencies/sample rates). The oversampling clock is network clock.

I²S master mode requires a 32-bit word length, regardless of the actual data type. Consequently, the fixed I²S frame rate of 64 bits per frame (word length (TCCR[WL]) can be any value) and TCCR[DC] = 1 are assumed.

Table 49-52. I²S system clock, bit clock, frame clock in master mode

Sampling/frame rate (kHz)	Over- sampling rate	MCLK/network clock freq (MHz)	TCCR			Bit clk (kHz) STCK
			DIV2	PS R	PM	
44.10	384	16.934	0	0	2	2822.33
22.05	384	16.934	0	0	5	1411.17
11.025	384	16.934	0	0	11	705.58
48.00	256	12.288	0	0	1	3072

49.4.3 External frame and clock operation

When applying external frame sync and clock signals to I²S, there should be at least four bit-clock cycles between the enabling of the transmit or receive section and the rising edge of the corresponding frame sync signal. The transition of TFS or RFS should be synchronized with the rising edge of external clock signal, STCK or SRCK.

Table 49-53. Data alignment (continued)

24-bit lsb aligned		23:0
24-bit msb aligned	23:0	

In addition, if lsb alignment is selected, the receive data can be zero-extended or sign-extended.

- In zero-extension, all bits above the most significant bit are 0s. This format is useful when data is stored in a pure integer format.
- In sign-extension, all bits above the most significant bit are equal to the most significant bit. This format is useful when data is stored in a fixed-point integer format (which implies fractional values).

The RCR[RXEXT] bit controls receive data extension. Transmit data used with lsb alignment has no concept of sign/zero-extension. Unused bits above the most significant bit are simply ignored.

When configured in I²S or AC97 mode, the I²S forces the selection of lsb alignment. However, RXEXT chooses zero-extension and sign-extension.

49.4.4 Receive interrupt enable bit description

If the receive FIFO is not enabled and the IER[RIE] and CR[RE] bits are set:

- an interrupt occurs when the corresponding I²S receive data ready (ISR[RDR0/1]) bit is set
- one value can be read from the RX register (one each in two-channel mode)

If the receive FIFO is enabled and the IER[RIE] and CR[RE] bits are set:

- an interrupt occurs when either of the I²S receive FIFO full (ISR[RFF0/1]) bits is set
- a maximum of 15 values are available to be read (15 values per channel in two-channel mode)

If the IER[RIE] bit is cleared, these interrupts are disabled. However, the RFF0/1 and RDR0/1 bits indicate the receive data register full condition. Reading the RX registers clears the ISR[RDR] bits, thus clearing the pending interrupt. Two receive data interrupts (two per channel in two-channel mode) are available: receive data with exception status and receive data without exception. The following table shows the conditions under which these interrupts are generated.

Table 49-54. I²S receive data interrupts

Interrupt	RIE	ROEn	RFFn/RDRn
Receive data 0 interrupts (n = 0)			
Receive data 0 (with exception status)	1	1	1
Receive data 0 (without exception)	1	0	1
Receive data 1 interrupts (n = 1)			
Receive data 1 (with exception status)	1	1	1
Receive data 1 (without exception)	1	0	1

49.4.5 Transmit interrupt enable bit description

If the transmit FIFO is not enabled and the IER[TIE] and CR[TE] bits are set:

- an interrupt occurs when the corresponding I²S transmit data register empty (ISR[TDE0/1]) flag is set
- one value can be written to the I²S_TX0 register (one per channel, in two-channel mode using I²S_TX1)

If the transmit FIFO is enabled and the IER[TIE] and CR[TE] bits are set:

- an interrupt occurs when either of the I²S transmit FIFO empty (ISR[TFE0/1]) flags is set
- a maximum of 15 values can be written to the I²S (15 per channel in two-channel mode, using Tx FIFO 1)

When the IER[TIE] bit is cleared, all transmit interrupts are disabled. However, the ISR[TDE0/1] bits always indicate the corresponding TX register empty condition, even when the transmitter is disabled by the transmit enable (CR[TE]) bit. Writing data to the TX clears the corresponding ISR[TDE] bit, thus clearing the interrupt.

Two transmit data interrupts are available (four in two-channel mode, two per channel): transmit data with exception status and transmit data without exceptions. The following table shows the conditions under which these interrupts are generated.

Table 49-55. I²S transmit data interrupts

Interrupt	TIE	TUEn	TFEn/TDEn
Transmit data 0 interrupts (n = 0)			
Transmit data 1 (with exception status)	1	1	1

Table continues on the next page...

Table 49-55. I²S transmit data interrupts (continued)

Interrupt	TIE	TUEn	TFEn/TDEn
Transmit data 1 (without exception)	1	0	1
Transmit data 1 interrupts (n = 1)			
Transmit data 0 (with exception status)	1	1	1
Transmit data 0 (without exception)	1	0	1

49.4.6 Internal frame and clock shutdown

During transmit/receive operation, clearing TE/RE stops data transmission/reception when the current frame ends. If the CR[TFRCLKDIS, RFRCLKDIS] bit is set in the current or previous frames, the I²S stops driving the frame sync and clock signals when the current frame ends. After this, the TCR[TFRC]] and TCR[RFRC] status bits are set to indicate the frame completion state. If TE is cleared four clock cycles before the next frame, an extra invalid frame is generated.

The following figure is an illustration of transmission case where:

- TCR[TXDIR] and TCR[TFDIR] are set
- CR[TE] is cleared
- CR[TFRCLKDIS] is set during the current or previous frame

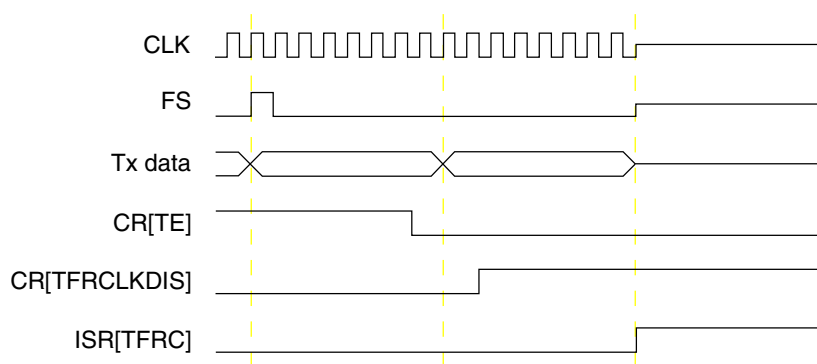

Figure 49-59. CR[TFRCLKDIS] assertion in current or previous frame as CR[TE] is Disabled

If CR[TFRCLKDIS or RFRCLKDIS] bit is not set while CR[TE or RE] is cleared, the I²S continues generating frame sync and clock signals (if direction is from the I²S), Upon setting CR[TFRCLKDIS or RFRCLKDIS], the I²S stops driving these signals at the end of the current frame. Following this, the TFRC/RFRC status bits are set to indicate the frame completion state.

The following figure illustrates a transmission case where:

- TCR[TXDIR] and TCR[TFDIR] are set
- CR[TFRCLKDIS] is set a few frames after clearing CR[TE]
- ISR[TRFC] is set at the frame boundary after CR[TE] is cleared. Once software services this interrupt and later sets CR[TFRCLKDIS] bit, the ISR[TRFC] bit is set again at next frame boundary.

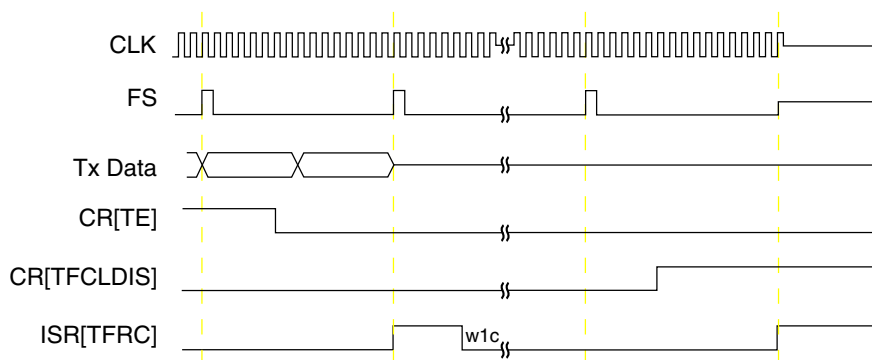

Figure 49-60. CR[TFRCLKDIS] assertion in subsequent frame after disabling CR[TE]

49.4.7 Reset

The I²S is affected by the following types of reset:

- Power-on reset—This reset clears the CR[I2SEN] bit, which disables the I²S. All other status and control bits in the I²S are affected as described in [Memory map/register definition](#).
- I²S reset—The I²S reset is generated when the CR[I2SEN] bit is cleared. The I²S status bits are reset to the same state produced by the power-on reset. The I²S control bits, including those in CR register, are unaffected. The I²S reset is useful for selective reset of the I²S, without changing the present I²S control bits and without affecting other peripherals.

49.5 Initialization/application information

The correct sequence to initialize the I²S is as follows:

1. Issue a power-on or I²S reset (CR[I2SEN] = 0).

2. Set all control bits for configuring the I²S (see the following table).
3. Enable appropriate interrupts/DMA requests through IER.
4. Set the CR[I2SEN] bit to enable the I²S.
5. In AC97 mode, set the ACNT[AC97EN] bit after programming the ATAG register (if needed, for AC97 Fixed mode).
6. In AC97 fixed mode, do not program the slot request bits without programming the frame valid bits in ATAG register.
7. In gated clock mode, refer to [Table 49-3](#).
8. Set CR[TE/RE] bits.

To ensure proper operation of the I²S, use the power-on or I²S reset before changing any of the I²S control bits listed in the following table.

Note

These control bits should not be changed when the I²S module is enabled

Table 49-56. I²S control bits requiring I²S to be disabled before change

Control Register	Bit
CR	[9]=CLKIST
	[8]=TCHEN
	[7]=SYSCLKEN
	[6:5]=I2SMODE
	[4]=SYN
IER	[3]=NET
	[22]=RDMAE
	[20]=TDMAE

Table continues on the next page...

Table 49-56. I²S control bits requiring I²S to be disabled before change (continued)

Control Register	Bit
RCR	[9]=RXBIT0
TCR	[9]=TXBIT0
	[8]=RFEN1
	[8]=TFEN1
	[7]=RFEN0
	[7]=TFEN0
	[6]=RFDIR
	[6]=TFDIR
	[5]=RXDIR
	[5]=TXDIR
	[4]=RSHFD
	[4]=TSHFD
	[3]=RSCKP
	[3]=TSCKP
	[2]=RFSI
	[2]=TFSI
	[1]=RFSL
	[1]=TFSL
	[0]=REFS
	[0]=TEFS
RCCR	[16]=WL3
TCCR	[15]=WL2
	[14]=WL1
	[13]=WL0
ACNT	[1]=FV
	[10:5]=FRDIV
PHCONFIG	[10:7]=CLKSRCSEL
	[0:2]=GAINSEL

Chapter 50

General purpose input/output (GPIO)

50.1 Introduction

NOTE

For the chip-specific implementation details of this module's instances see the chip configuration chapter.

The general purpose input and output (GPIO) module interfaces to the processor core via a zero wait state interface for maximum pin performance. Accesses of any data size are supported to the GPIO registers.

The GPIO data direction and output data registers control the direction and output data of each pin when the pin is configured for the GPIO function. The GPIO input data register displays the logic value on each pin when the pin is configured for any digital function, provided the corresponding port control and interrupt module for that pin is enabled.

Efficient bit banging of the general purpose outputs is supported through the addition of set, clear and toggle write-only registers for each port output data register.

50.1.1 Features

- Rapid general purpose input and output
 - Pin input data register visible in all digital pin-muxing modes
 - Pin output data register with corresponding set/clear/toggle registers
 - Pin data direction register
 - Zero wait state access to GPIO registers

50.1.2 Modes of operation

50.1.2.1 Run mode

In run mode, the GPIO operates normally.

50.1.2.2 Wait mode

In wait mode, the GPIO operates normally.

50.1.2.3 Stop mode

The GPIO is disabled in stop mode, although the pins retain their state.

50.1.2.4 Debug mode

In debug mode, the GPIO operates normally.

50.1.3 GPIO signal descriptions

Table 50-1. GPIO signal descriptions

Signal	Description	I/O
PORTA[31:0]	General purpose input/output	I/O
PORTB[31:0]	General purpose input/output	I/O
PORTC[31:0]	General purpose input/output	I/O
PORTD[31:0]	General purpose input/output	I/O
PORTE[31:0]	General purpose input/output	I/O

NOTE

Not all pins within each port are implemented on each device. Refer to the Signal Multiplexing chapter for the number of GPIO ports available in the device.

50.1.3.1 Detailed signal description

Table 50-2. GPIO interface-detailed signal descriptions

Signal	I/O	Description	
PORTA[31:0] PORTB[31:0] PORTC[31:0] PORTD[31:0] PORTE[31:0]	I/O	General purpose input/output.	
		State meaning	Asserted - pin is logic one. Negated - pin is logic zero.
		Timing	Assertion - when output, occurs on rising edge of the system clock. For input, may occur at any time and input may be asserted asynchronously to the system clock. Negation - when output, occurs on rising edge of the system clock. For input, may occur at any time and input may be asserted asynchronously to the system clock.

50.2 Memory map and register definition

Any read or write access to the GPIO memory space that is outside the valid memory map results in a bus error. All register accesses complete with zero wait states, except error accesses which complete with one wait state.

GPIO memory map

Absolute address (hex)	Register name	Width (in bits)	Access	Reset value	Section/page
400F_F000	Port Data Output Register (GPIOA_PDOR)	32	R/W	0000_0000h	50.2.1/1514
400F_F004	Port Set Output Register (GPIOA_PSOR)	32	W (always reads zero)	0000_0000h	50.2.2/1514
400F_F008	Port Clear Output Register (GPIOA_PCOR)	32	W (always reads zero)	0000_0000h	50.2.3/1515
400F_F00C	Port Toggle Output Register (GPIOA_PTOR)	32	W (always	0000_0000h	50.2.4/1515

Table continues on the next page...

GPIO memory map (continued)

Absolute address (hex)	Register name	Width (in bits)	Access	Reset value	Section/page
			reads zero)		
400F_F010	Port Data Input Register (GPIOA_PDIR)	32	R	0000_0000h	50.2.5/1516
400F_F014	Port Data Direction Register (GPIOA_PDDR)	32	R/W	0000_0000h	50.2.6/1516
400F_F040	Port Data Output Register (GPIOB_PDOR)	32	R/W	0000_0000h	50.2.1/1514
400F_F044	Port Set Output Register (GPIOB_PSOR)	32	W (always reads zero)	0000_0000h	50.2.2/1514
400F_F048	Port Clear Output Register (GPIOB_PCOR)	32	W (always reads zero)	0000_0000h	50.2.3/1515
400F_F04C	Port Toggle Output Register (GPIOB_PTOR)	32	W (always reads zero)	0000_0000h	50.2.4/1515
400F_F050	Port Data Input Register (GPIOB_PDIR)	32	R	0000_0000h	50.2.5/1516
400F_F054	Port Data Direction Register (GPIOB_PDDR)	32	R/W	0000_0000h	50.2.6/1516
400F_F080	Port Data Output Register (GPIOC_PDOR)	32	R/W	0000_0000h	50.2.1/1514
400F_F084	Port Set Output Register (GPIOC_PSOR)	32	W (always reads zero)	0000_0000h	50.2.2/1514
400F_F088	Port Clear Output Register (GPIOC_PCOR)	32	W (always reads zero)	0000_0000h	50.2.3/1515
400F_F08C	Port Toggle Output Register (GPIOC_PTOR)	32	W (always reads zero)	0000_0000h	50.2.4/1515
400F_F090	Port Data Input Register (GPIOC_PDIR)	32	R	0000_0000h	50.2.5/1516
400F_F094	Port Data Direction Register (GPIOC_PDDR)	32	R/W	0000_0000h	50.2.6/1516
400F_F0C0	Port Data Output Register (GPIOD_PDOR)	32	R/W	0000_0000h	50.2.1/1514

Table continues on the next page...

GPIO memory map (continued)

Absolute address (hex)	Register name	Width (in bits)	Access	Reset value	Section/page
400F_F0C4	Port Set Output Register (GPIOD_PSOR)	32	W (always reads zero)	0000_0000h	50.2.2/1514
400F_F0C8	Port Clear Output Register (GPIOD_PCOR)	32	W (always reads zero)	0000_0000h	50.2.3/1515
400F_F0CC	Port Toggle Output Register (GPIOD_PTOR)	32	W (always reads zero)	0000_0000h	50.2.4/1515
400F_F0D0	Port Data Input Register (GPIOD_PDIR)	32	R	0000_0000h	50.2.5/1516
400F_F0D4	Port Data Direction Register (GPIOD_PDDR)	32	R/W	0000_0000h	50.2.6/1516
400F_F100	Port Data Output Register (GPIOE_PDOR)	32	R/W	0000_0000h	50.2.1/1514
400F_F104	Port Set Output Register (GPIOE_PSOR)	32	W (always reads zero)	0000_0000h	50.2.2/1514
400F_F108	Port Clear Output Register (GPIOE_PCOR)	32	W (always reads zero)	0000_0000h	50.2.3/1515
400F_F10C	Port Toggle Output Register (GPIOE_PTOR)	32	W (always reads zero)	0000_0000h	50.2.4/1515
400F_F110	Port Data Input Register (GPIOE_PDIR)	32	R	0000_0000h	50.2.5/1516
400F_F114	Port Data Direction Register (GPIOE_PDDR)	32	R/W	0000_0000h	50.2.6/1516

50.2.1 Port Data Output Register (GPIOx_PDOR)

Addresses: GPIOA_PDOR is 400F_F000h base + 0h offset = 400F_F000h

GPIOB_PDOR is 400F_F040h base + 0h offset = 400F_F040h

GPIOC_PDOR is 400F_F080h base + 0h offset = 400F_F080h

GPIOD_PDOR is 400F_F0C0h base + 0h offset = 400F_F0C0h

GPIOE_PDOR is 400F_F100h base + 0h offset = 400F_F100h

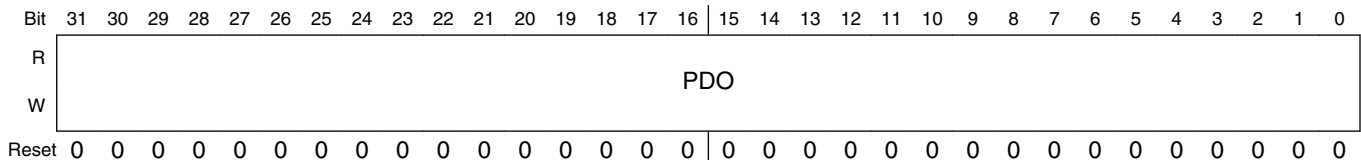

GPIOx_PDOR field descriptions

Field	Description
31–0 PDO	<p>Port Data Output</p> <p>Unimplemented pins for a particular device read as zero.</p> <p>0 Logic level 0 is driven on pin provided pin is configured for General Purpose Output.</p> <p>1 Logic level 1 is driven on pin provided pin is configured for General Purpose Output.</p>

50.2.2 Port Set Output Register (GPIOx_PSOR)

Addresses: GPIOA_PSOR is 400F_F000h base + 4h offset = 400F_F004h

GPIOB_PSOR is 400F_F040h base + 4h offset = 400F_F044h

GPIOC_PSOR is 400F_F080h base + 4h offset = 400F_F084h

GPIOD_PSOR is 400F_F0C0h base + 4h offset = 400F_F0C4h

GPIOE_PSOR is 400F_F100h base + 4h offset = 400F_F104h

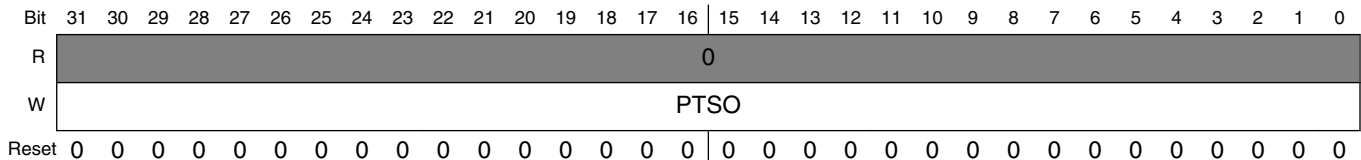

GPIOx_PSOR field descriptions

Field	Description
31–0 PTSO	<p>Port Set Output</p> <p>Writing to this register will update the contents of the corresponding bit in the Port Data Output Register (PDOR) as follows:</p> <p>0 Corresponding bit in PDORn does not change.</p> <p>1 Corresponding bit in PDORn is set to logic one.</p>

50.2.3 Port Clear Output Register (GPIOx_PCOR)

Addresses: GPIOA_PCOR is 400F_F000h base + 8h offset = 400F_F008h
 GPIOB_PCOR is 400F_F040h base + 8h offset = 400F_F048h
 GPIOC_PCOR is 400F_F080h base + 8h offset = 400F_F088h
 GPIOD_PCOR is 400F_F0C0h base + 8h offset = 400F_F0C8h
 GPIOE_PCOR is 400F_F100h base + 8h offset = 400F_F108h

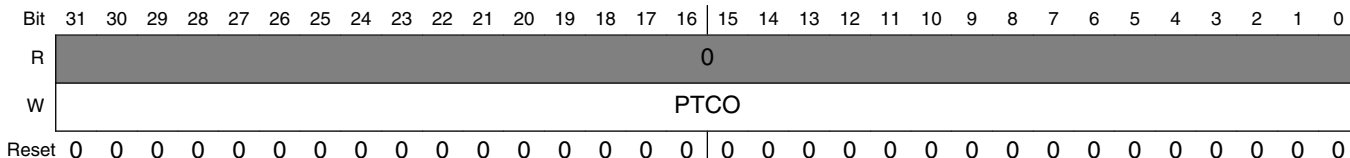

GPIOx_PCOR field descriptions

Field	Description
31–0 PTCO	Port Clear Output Writing to this register will update the contents of the corresponding bit in the Port Data Output Register (PDOR) as follows: 0 Corresponding bit in PDORn does not change. 1 Corresponding bit in PDORn is set to logic zero.

50.2.4 Port Toggle Output Register (GPIOx_PTOR)

Addresses: GPIOA_PTOR is 400F_F000h base + Ch offset = 400F_F00Ch
 GPIOB_PTOR is 400F_F040h base + Ch offset = 400F_F04Ch
 GPIOC_PTOR is 400F_F080h base + Ch offset = 400F_F08Ch
 GPIOD_PTOR is 400F_F0C0h base + Ch offset = 400F_F0CCh
 GPIOE_PTOR is 400F_F100h base + Ch offset = 400F_F10Ch

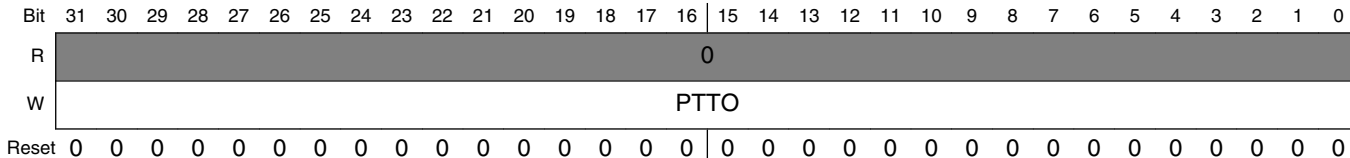

GPIOx_PTOR field descriptions

Field	Description
31–0 PTTO	Port Toggle Output Writing to this register will update the contents of the corresponding bit in the Port Data Output Register (PDOR) as follows:

GPIOx_PTOR field descriptions (continued)

Field	Description
0	Corresponding bit in PDORn does not change.
1	Corresponding bit in PDORn is set to the inverse of its existing logic state.

50.2.5 Port Data Input Register (GPIOx_PDIR)

Addresses: GPIOA_PDIR is 400F_F000h base + 10h offset = 400F_F010h
 GPIOB_PDIR is 400F_F040h base + 10h offset = 400F_F050h
 GPIOC_PDIR is 400F_F080h base + 10h offset = 400F_F090h
 GPIOD_PDIR is 400F_F0C0h base + 10h offset = 400F_F0D0h
 GPIOE_PDIR is 400F_F100h base + 10h offset = 400F_F110h

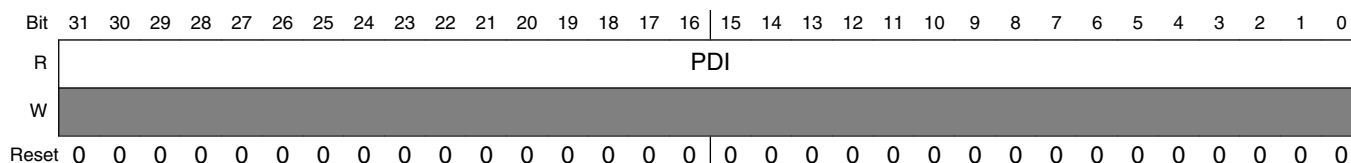

GPIOx_PDIR field descriptions

Field	Description
31–0 PDI	<p>Port Data Input</p> <p>Unimplemented pins for a particular device read as zero. Pins that are not configured for a digital function read as zero. If the corresponding Port Control and Interrupt module is disabled, then that Port Data Input Register does not update.</p> <p>0 Pin logic level is logic zero or is configured for use by digital function. 1 Pin logic level is logic one.</p>

50.2.6 Port Data Direction Register (GPIOx_PDDR)

The PDDR configures the individual port pins for input or output.

Addresses: GPIOA_PDDR is 400F_F000h base + 14h offset = 400F_F014h
 GPIOB_PDDR is 400F_F040h base + 14h offset = 400F_F054h
 GPIOC_PDDR is 400F_F080h base + 14h offset = 400F_F094h
 GPIOD_PDDR is 400F_F0C0h base + 14h offset = 400F_F0D4h
 GPIOE_PDDR is 400F_F100h base + 14h offset = 400F_F114h

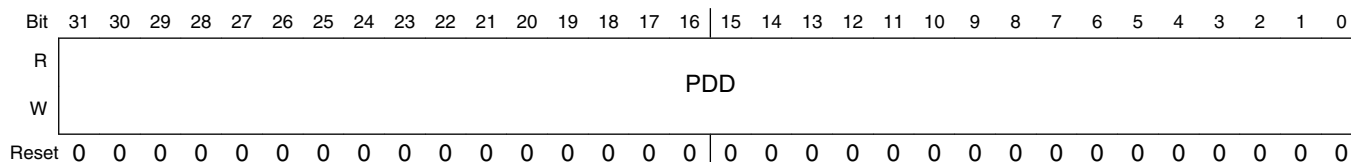

GPIOx_PDDR field descriptions

Field	Description
31–0 PDD	Port data direction 0 Pin is configured as general purpose input, if configured for the GPIO function 1 Pin is configured for general purpose output, if configured for the GPIO function

50.3 Functional description

50.3.1 General purpose input

The logic state of each pin is available via the pin data input registers, provided the pin is configured for a digital function and the corresponding port control and interrupt module is enabled.

The pin data input registers return the synchronized pin state after any enabled digital filter in the port control and interrupt module. The input pin synchronizers are shared with the port control and interrupt module, so that if the corresponding port control and interrupt module is disabled then synchronizers are also disabled. This reduces power consumption when a port is not required for general purpose input functionality.

50.3.2 General purpose output

The logic state of each pin can be controlled via the pin data output registers and pin output enable registers, provided the pin is configured for the GPIO function.

If a pin is configured for the GPIO function and the corresponding data output enable register bit is clear then the pin is configured as an input.

If a pin is configured for the GPIO function and the corresponding pin data output enable register bit is set then the pin is configured as an output and the logic state of the pin is equal to the corresponding pin data output register.

To facilitate efficient bit banging on the general purpose outputs, pin data set, pin data clear and pin data toggle registers exist to allow one or more outputs within the one port to be set, cleared or toggled from a single register write.

The corresponding port control and interrupt module does not need to be enabled to update the state of the pin output enable registers and pin data output registers (including the set/clear/toggle registers).

Chapter 51

Touch sense input (TSI)

51.1 Introduction

NOTE

For the chip-specific implementation details of this module's instances see the chip configuration chapter.

The touch sensing input (TSI) module provides capacitive touch sensing detection with high sensitivity and enhanced robustness. Each TSI pin implements the capacitive measurement of an electrode having individual programmable detection thresholds and result registers. The TSI module can be functional in several low power modes with ultra low current adder and waking up the CPU in a touch event. It provides a solid capacitive measurement module for the implementation of touch keypad, rotaries and sliders.

51.2 Features

- Support as many as 16 input capacitive touch sensing pins with individual result registers
- Automatic detection of electrode capacitance change with programmable upper and lower threshold
- Automatic periodic scan unit with different duty cycles for run and low power modes
- Full support with FSL touch sensing SW library (TSS) for the implementation of keypads, rotaries and sliders
- Operation across all low power modes: Wait, Stop, VLPR, VLPW, VLPS, LLS, VLLS{3,2,1}
- Capability to wake up MCU from low power modes
- Configurable interrupts:
 - End-of-scan or out-of-range interrupt
 - TSI error interrupts: pad short to V_{DD}/V_{SS} or conversion overrun
- Compensate temperature and supply voltage variations
- Stand alone operation not requiring any external crystal even in low power modes

- Configurable integration of each electrode capacitance measurement from 1 to 4096 times
- Programmable electrode oscillator and TSI Reference Oscillator for high sensitivity, small scan time and low power functionality
- Only uses one pin per electrode implementation with no external hardware required

51.3 Overview

This section presents an overview of the TSI module. The following figure presents the simplified TSI module block diagram.

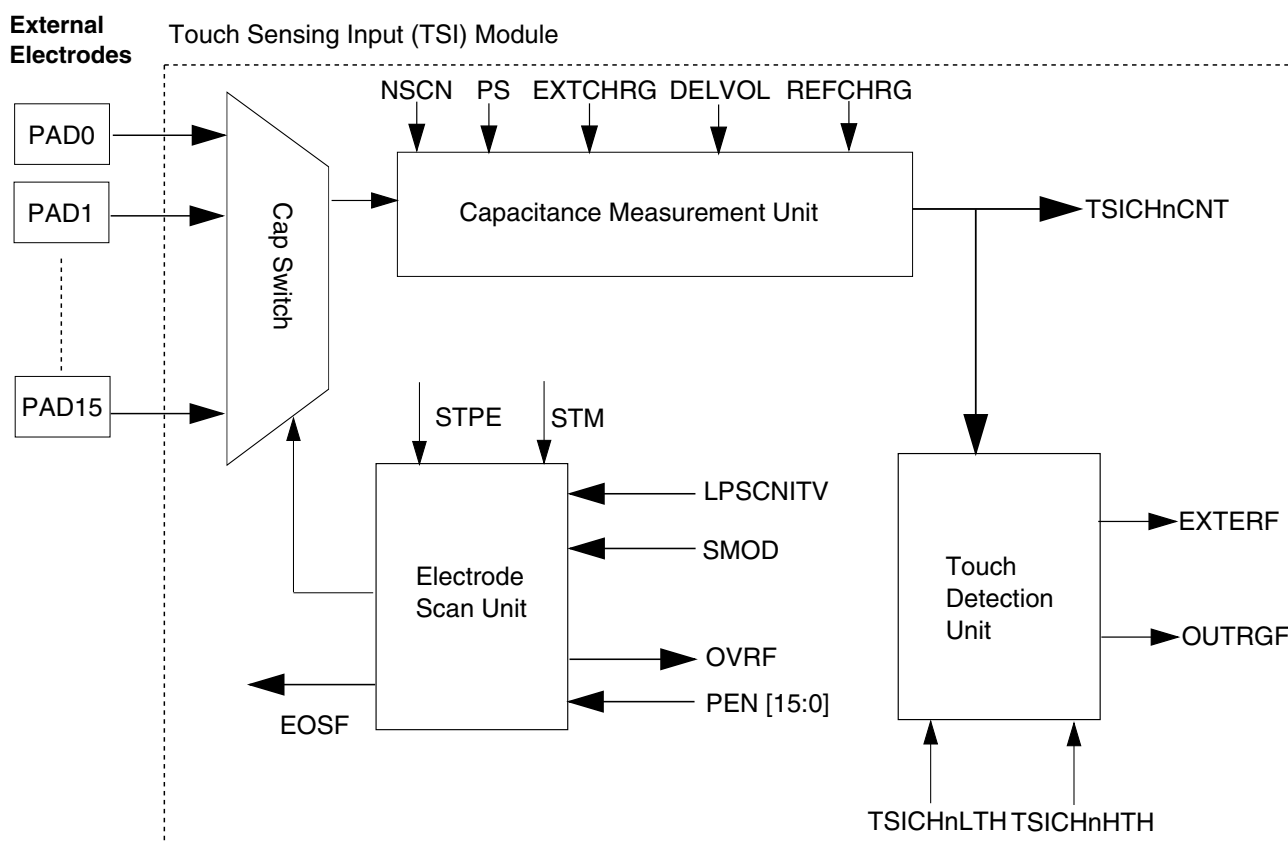

Figure 51-1. Touch sensing input block diagram

51.3.1 Electrode capacitance measurement unit

The electrode capacitance measurement unit senses the capacitance of a TSI pin and outputs a 16-bit result. This module is based in dual oscillator architecture. One oscillator is connected to the external electrode array and oscillates according to the electrode

capacitance, while the other according to an internal reference capacitor. The pin capacitance measurement is given by the counted number of periods of the reference oscillator during a configurable number of oscillations of the external electrode oscillator.

The electrode oscillator charges and discharges the pin capacitance with a programmable 5-bit binary current source in order to accommodate different sizes of electrode capacitance. The electrode oscillator frequency, before being compared to that of the reference oscillator, goes through a prescaler and modulo counter to decrease its frequency and consecutively increase the measurement resolution and noise robustness.

The following figure presents the simplified block diagram of how the electrode capacitance is measured.

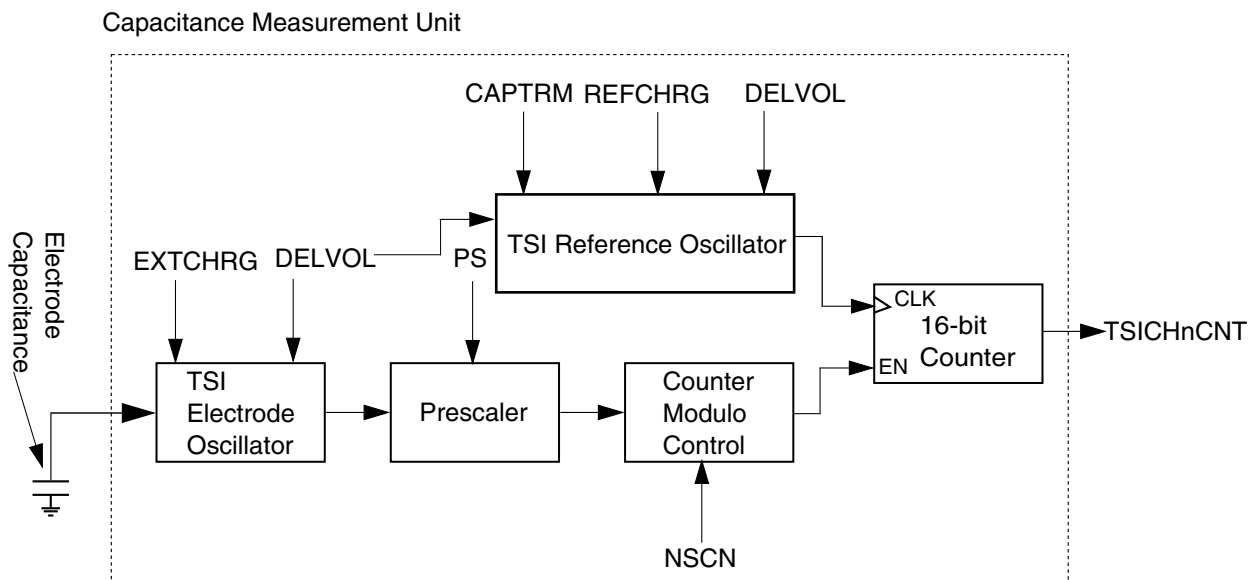

Figure 51-2. TSI capacitance measurement unit block diagram

51.3.2 Electrode scan unit

This section describes the functionality of the electrode scan unit. It is responsible for triggering the start of the active electrode scan.

The touch sense input module needs to periodically scan all active electrodes to determine if a touch event has occurred. The electrode scan unit has two independent scan periods, one for TSI active mode and the other for TSI low power mode. This independent control allows the application to configure longer scan period during low power mode, so contributing to smaller average power consumption. The TSI, in low power mode, has the capability to wake the CPU upon an electrode capacitance change. When the CPU wakes, the TSI enters active mode, and produces a shorter scan period for a faster response and more robust touch detection. Apart from the periodical mode, the

electrode scan unit also allows software triggering of the electrode scans. This feature is very useful for initialization of the touch application to detect the initial electrode capacitances. This module generates configurable end-of-scan interrupt to indicate the application that all electrodes were scanned. If a new electrode scan is started while the previous one is still in progress, an overrun error flag is generated, TSI continues the previous scan sequence and the latest trigger is ignored.

51.3.3 Touch detection unit

The touch detection unit indicates the change in the pin capacitance. This module compares the pin capacitance value in the result register with a pre-configured low and high threshold. If the capacitance result register value is outside the ranges defined by the upper and lower threshold, the touch detection unit generates an out-of-range flag to indicate a pin capacitance change.

The upper and lower threshold values are configurable allowing the application to select the magnitude of the capacitance change to trigger the out-of-range flag. With the threshold values programmed properly the application noise level does not cause frequent CPU interrupts, so minimizes the CPU touch application usage. This feature also allows the TSI to wake up the CPU from low power modes only in a capacitance change event.

51.4 Modes of operation

The TSI module has three operation modes: disabled, active mode and low power mode.

51.4.1 TSI disabled mode

When GENCS[TSIEN] is cleared, the TSI module is disabled.

51.4.2 TSI active mode

In active mode, the TSI module has its full functionality, being able to scan up to 16 electrodes. The TSI can be in active mode with the MCU in Run, Wait, VLPR, and VLPW modes, and the TSI can run in low power mode (only one electrode scanning in Stop, VLPS, LLS, and VLLSx modes).

Three clock sources can be selected for the TSI module in active mode: BUS_CLK, MCGIRCLK and OSCERCLK.

51.4.3 TSI low power mode

The TSI module enters low power mode if the GENCS[STPE] is set to one and the MCU is programmed into one of the following operational modes: LLS, VLLS1, VLLS2 or VLLS3. In low power mode, only one selectable pin is active, being able to perform capacitance measurements. The scan period is defined by GENCS[LPSCNITV]. Two low power clock sources are available in the TSI low power mode, LPOCLK and VLPOSCCLK, being selected by the GENCS[LPCLKS].

In low power mode the TSI interrupt can also be configured as end-of-scan or out-of-range and the GENCS[TSIIEN] must be set in order to generate these interrupts. The TSI interrupt causes the exit of the low power mode, entrance into the active mode, and the MCU wake up.

In low power mode the electrode scan unit is always configured to periodical low power scan.

51.4.4 Block diagram

The following figure shows the block diagram of TSI module.

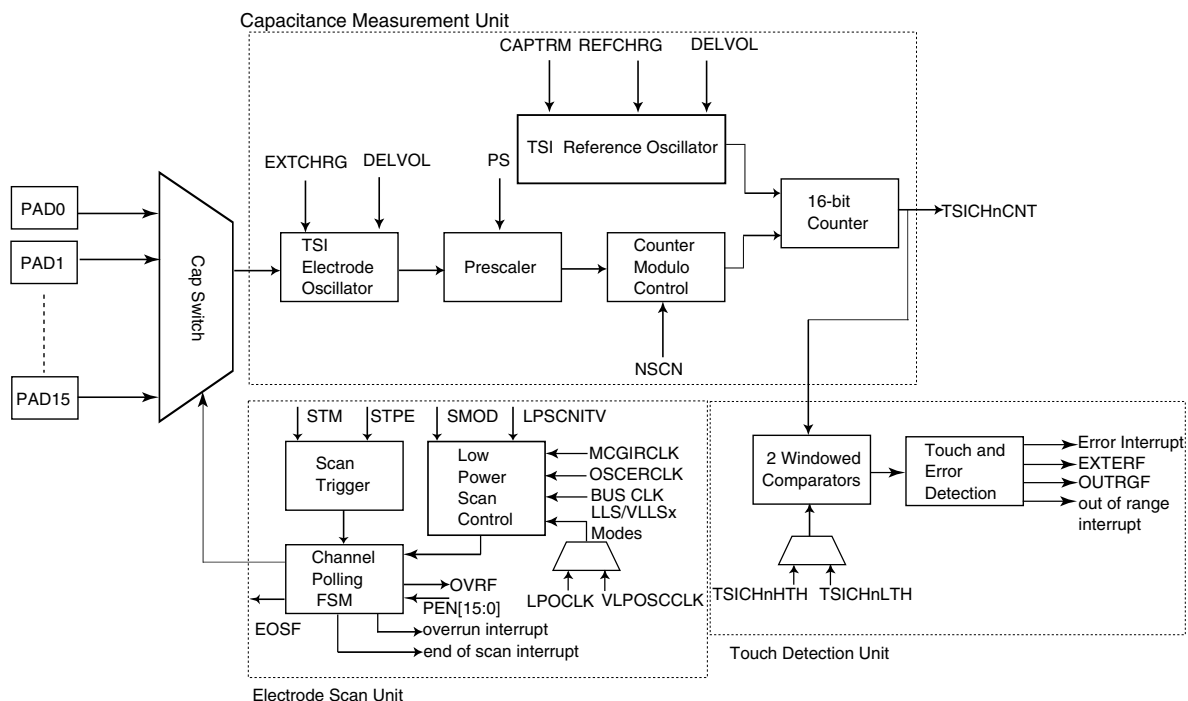

Figure 51-3. TSI block diagram

51.5 TSI signal descriptions

The TSI module has up to 16 external pins for touch sensing. The table below itemizes all the TSI external pins.

Table 51-1. TSI signal descriptions

Signal	Description	I/O
TSI_IN[15:0]	TSI pins. Switchable driver that connects directly to the electrode pins TSI[15:0] can operate as GPIO pins	I/O

51.5.1 TSI_IN[15:0]

When TSI functionality is enabled by the PEN[PEN], the TSI analog portion uses corresponding TSICH_n to connect external on-board touch capacitors. The connection between the pin and the touch pad must be kept as short as possible to reduce distribution capacity on board that will add to the system base capacitance.

51.6 Memory map and register definition

This section presents the touch sensing input module memory map and registers definition.

TSI memory map

Absolute address (hex)	Register name	Width (in bits)	Access	Reset value	Section/page
4004_5000	General Control and Status Register (TSI0_GENCS)	32	R/W	0000_0000h	51.6.1/1526
4004_5004	SCAN control register (TSI0_SCANC)	32	R/W	0000_0000h	51.6.2/1529
4004_5008	Pin enable register (TSI0_PEN)	32	R/W	0000_0000h	51.6.3/1532
4004_500C	Status Register (TSI0_STATUS)	32	w1c	0000_0000h	51.6.4/1535
4004_5100	Counter Register (TSI0_CNTR1)	32	R	0000_0000h	51.6.5/1538

Table continues on the next page...

TSI memory map (continued)

Absolute address (hex)	Register name	Width (in bits)	Access	Reset value	Section/page
4004_5104	Counter Register (TSI0_CNTR3)	32	R	0000_0000h	51.6.5/ 1538
4004_5108	Counter Register (TSI0_CNTR5)	32	R	0000_0000h	51.6.5/ 1538
4004_510C	Counter Register (TSI0_CNTR7)	32	R	0000_0000h	51.6.5/ 1538
4004_5110	Counter Register (TSI0_CNTR9)	32	R	0000_0000h	51.6.5/ 1538
4004_5114	Counter Register (TSI0_CNTR11)	32	R	0000_0000h	51.6.5/ 1538
4004_5118	Counter Register (TSI0_CNTR13)	32	R	0000_0000h	51.6.5/ 1538
4004_511C	Counter Register (TSI0_CNTR15)	32	R	0000_0000h	51.6.5/ 1538
4004_5120	Channel n threshold register (TSI0_THRESHLD0)	32	R/W	0000_0000h	51.6.6/ 1539
4004_5124	Channel n threshold register (TSI0_THRESHLD1)	32	R/W	0000_0000h	51.6.6/ 1539
4004_5128	Channel n threshold register (TSI0_THRESHLD2)	32	R/W	0000_0000h	51.6.6/ 1539
4004_512C	Channel n threshold register (TSI0_THRESHLD3)	32	R/W	0000_0000h	51.6.6/ 1539
4004_5130	Channel n threshold register (TSI0_THRESHLD4)	32	R/W	0000_0000h	51.6.6/ 1539
4004_5134	Channel n threshold register (TSI0_THRESHLD5)	32	R/W	0000_0000h	51.6.6/ 1539
4004_5138	Channel n threshold register (TSI0_THRESHLD6)	32	R/W	0000_0000h	51.6.6/ 1539
4004_513C	Channel n threshold register (TSI0_THRESHLD7)	32	R/W	0000_0000h	51.6.6/ 1539
4004_5140	Channel n threshold register (TSI0_THRESHLD8)	32	R/W	0000_0000h	51.6.6/ 1539
4004_5144	Channel n threshold register (TSI0_THRESHLD9)	32	R/W	0000_0000h	51.6.6/ 1539
4004_5148	Channel n threshold register (TSI0_THRESHLD10)	32	R/W	0000_0000h	51.6.6/ 1539
4004_514C	Channel n threshold register (TSI0_THRESHLD11)	32	R/W	0000_0000h	51.6.6/ 1539
4004_5150	Channel n threshold register (TSI0_THRESHLD12)	32	R/W	0000_0000h	51.6.6/ 1539

Table continues on the next page...

TSI memory map (continued)

Absolute address (hex)	Register name	Width (in bits)	Access	Reset value	Section/page
4004_5154	Channel n threshold register (TSI0_THRESHLD13)	32	R/W	0000_0000h	51.6.6/ 1539
4004_5158	Channel n threshold register (TSI0_THRESHLD14)	32	R/W	0000_0000h	51.6.6/ 1539
4004_515C	Channel n threshold register (TSI0_THRESHLD15)	32	R/W	0000_0000h	51.6.6/ 1539

51.6.1 General Control and Status Register (TSIx_GENCS)

All GENCS bits can be read at any time, but must not be written while GENCS[SCNIP] is set.

Addresses: TSI0_GENCS is 4004_5000h base + 0h offset = 4004_5000h

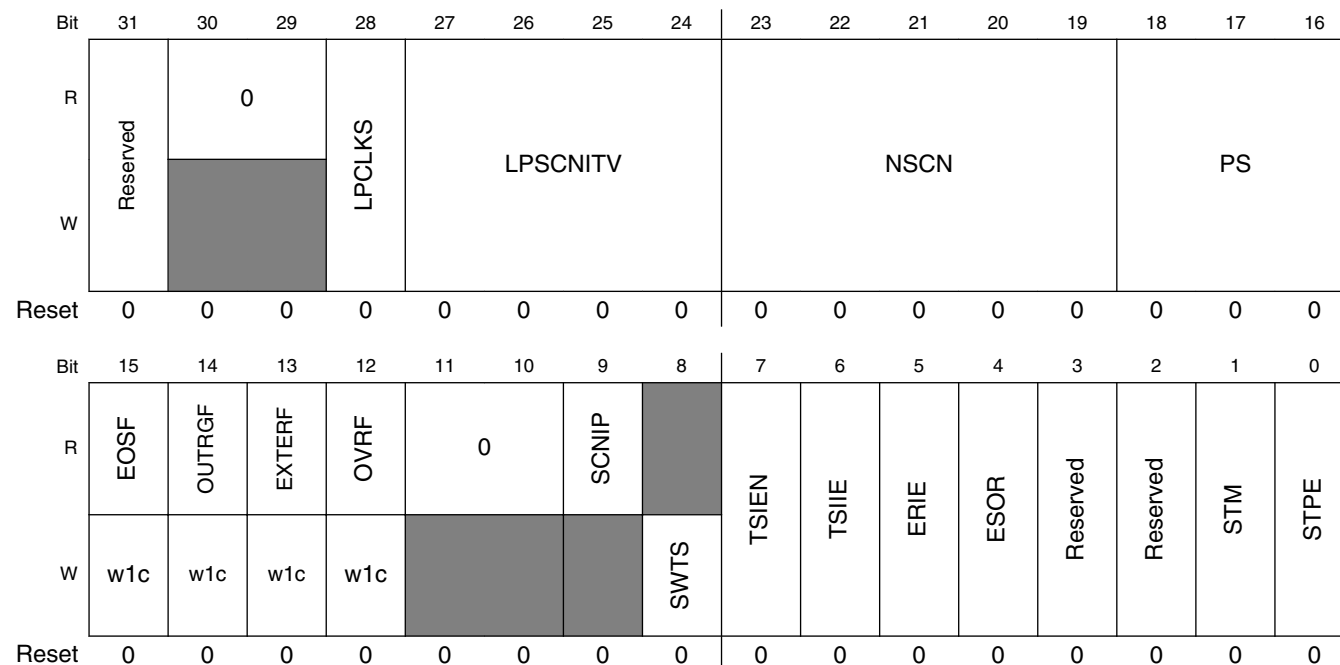

TSIx_GENCS field descriptions

Field	Description
31 Reserved	Reserved This field is reserved.
30–29 Reserved	This read-only field is reserved and always has the value zero.
28 LPCLKS	Low Power Mode Clock Source Selection

Table continues on the next page...

TSIx_GENCS field descriptions (continued)

Field	Description
	0 LPOCLK 1 VLPOSCCLK
27–24 LPSCNITV	TSI Low Power Mode Scan Interval 0000 1 ms scan interval 0001 5 ms scan interval 0010 10 ms scan interval 0011 15 ms scan interval 0100 20 ms scan interval 0101 30 ms scan interval 0110 40 ms scan interval 0111 50 ms scan interval 1000 75 ms scan interval 1001 100 ms scan interval 1010 125 ms scan interval 1011 150 ms scan interval 1100 200 ms scan interval 1101 300 ms scan interval 1110 400 ms scan interval 1111 500 ms scan interval
23–19 NSCN	Number of Consecutive Scans per Electrode 00000 1 time per electrode 00001 2 times per electrode 00010 3 times per electrode 00011 4 times per electrode 00100 5 times per electrode 00101 6 times per electrode 00110 7 times per electrode 00111 8 times per electrode 01000 9 times per electrode 01001 10 times per electrode 01010 11 times per electrode 01011 12 times per electrode 01100 13 times per electrode 01101 14 times per electrode 01110 15 times per electrode 01111 16 times per electrode 10000 17 times per electrode 10001 18 times per electrode 10010 19 times per electrode 10011 20 times per electrode 10100 21 times per electrode 10101 22 times per electrode 10110 23 times per electrode 10111 24 times per electrode 11000 25 times per electrode

Table continues on the next page...

TSIx_GENCS field descriptions (continued)

Field	Description
	11001 26 times per electrode 11010 27 times per electrode 11011 28 times per electrode 11100 29 times per electrode 11101 30 times per electrode 11110 31 times per electrode 11111 32 times per electrode
18–16 PS	Electrode oscillator prescaler 000 Electrode oscillator frequency divided by 1 001 Electrode oscillator frequency divided by 2 010 Electrode oscillator frequency divided by 4 011 Electrode oscillator frequency divided by 8 100 Electrode oscillator frequency divided by 16 101 Electrode oscillator frequency divided by 32 110 Electrode oscillator frequency divided by 64 111 Electrode oscillator frequency divided by 128
15 EOSF	End of scan flag Write 1 to clear the flag.
14 OUTRGF	Out of Range Flag Write 1 to clear the flag.
13 EXTERF	External electrode error occurred 0 No short 1 Short to VDD or VSS occurred on the electrodes
12 OVRF	Overrun error flag 0 No overrun 1 Overrun occurred
11–10 Reserved	This read-only field is reserved and always has the value zero.
9 SCNIP	Scan-in-progress status Indicates if a scanning process is in progress. This bit is read-only and is changed automatically by the TSI module.
8 SWTS	Software trigger start Setting this bit starts a scan sequence. Writing zero to this bit has no effect.
7 TSIEN	TSI module enable 0 TSI disabled 1 TSI enabled
6 TSIIE	TSI interrupt enable

Table continues on the next page...

TSIx_GENCS field descriptions (continued)

Field	Description
	0 Disable 1 Enable
5 ERIE	TSI error interrupt Enable Caused by a short or overrun error. 0 Error interrupt disabled 1 Error interrupt enabled
4 ESOR	End-of-scan or out-of-range interrupt select 0 Out-of-range interrupt selected 1 End-of-scan interrupt selected
3 Reserved	Reserved This field is reserved.
2 Reserved	Reserved This field is reserved.
1 STM	Scan trigger mode 0 Software trigger scan 1 Periodical scan
0 STPE	TSI stop enable while in low-power modes (STOP, VLPS, LLS, and VLLS{3,2,1}) 0 Disable TSI when MCU enters low-power modes 1 Allow TSI to continue running in all low power modes

51.6.2 SCAN control register (TSIx_SCANC)

All SCANC bits can be read at any time, but must not be written while GENCS[SCNIP] is set.

Addresses: TSI0_SCANC is 4004_5000h base + 4h offset = 4004_5004h

Bit	31	30	29	28	27	26	25	24	23	22	21	20	19	18	17	16		
R	REFCHRG								CAPTRM				EXTCHRG				DELVOL	
W	REFCHRG								CAPTRM				EXTCHRG				DELVOL	
Reset	0	0	0	0	0	0	0	0	0	0	0	0	0	0	0	0		
Bit	15	14	13	12	11	10	9	8	7	6	5	4	3	2	1	0		
R	SMOD								0		AMCLKDIV	AMCLKS		AMPSC				
W	SMOD								0		AMCLKDIV	AMCLKS		AMPSC				
Reset	0	0	0	0	0	0	0	0	0	0	0	0	0	0	0	0		

TS1x_SCANC field descriptions

Field	Description
31–27 REFCHRG	Reference oscillator charge current select 00000 1 μ A charge current 00001 2 μ A charge current 00010 3 μ A charge current 00011 4 μ A charge current 00100 5 μ A charge current 00101 6 μ A charge current 00110 7 μ A charge current 00111 8 μ A charge current 01000 9 μ A charge current 01001 10 μ A charge current 01010 11 μ A charge current 01011 12 μ A charge current 01100 13 μ A charge current 01101 14 μ A charge current 01110 15 μ A charge current 01111 16 μ A charge current 10000 17 μ A charge current 10001 18 μ A charge current 10010 19 μ A charge current 10011 20 μ A charge current 10100 21 μ A charge current 10101 22 μ A charge current 10110 23 μ A charge current 10111 24 μ A charge current 11000 25 μ A charge current 11001 26 μ A charge current 11010 27 μ A charge current 11011 28 μ A charge current 11100 29 μ A charge current 11101 30 μ A charge current 11110 31 μ A charge current 11111 32 μ A charge current
26–24 CAPTRM	Internal capacitance trim value 000 0.5 pF internal reference capacitance 001 0.6 pF internal reference capacitance 010 0.7 pF internal reference capacitance 011 0.8 pF internal reference capacitance 100 0.9 pF internal reference capacitance 101 1.0 pF internal reference capacitance 110 1.1 pF internal reference capacitance 111 1.2 pF internal reference capacitance
23–19 EXTCHRG	External oscillator charge current select 00000 1 μ A charge current

Table continues on the next page...

TSIx_SCANC field descriptions (continued)

Field	Description
	00001 2 μ A charge current 00010 3 μ A charge current 00011 4 μ A charge current 00100 5 μ A charge current 00101 6 μ A charge current 00110 7 μ A charge current 00111 8 μ A charge current 01000 9 μ A charge current 01001 10 μ A charge current 01010 11 μ A charge current 01011 12 μ A charge current 01100 13 μ A charge current 01101 14 μ A charge current 01110 15 μ A charge current 01111 16 μ A charge current 10000 17 μ A charge current 10001 18 μ A charge current 10010 19 μ A charge current 10011 20 μ A charge current 10100 21 μ A charge current 10101 22 μ A charge current 10110 23 μ A charge current 10111 24 μ A charge current 11000 25 μ A charge current 11001 26 μ A charge current 11010 27 μ A charge current 11011 28 μ A charge current 11100 29 μ A charge current 11101 30 μ A charge current 11110 31 μ A charge current 11111 32 μ A charge current
18–16 DELVOL	Delta voltage select applied to analog oscillators 000 100 mV delta voltage is applied 001 150 mV delta voltage is applied 010 200 mV delta voltage is applied 011 250 mV delta voltage is applied 100 300 mV delta voltage is applied 101 400 mV delta voltage is applied 110 500 mV delta voltage is applied 111 600 mV delta voltage is applied
15–8 SMOD	Scan modulo 00000000 Continuous scan Others Scan period modulo
7–6 Reserved	This read-only field is reserved and always has the value zero.

Table continues on the next page...

TSIx_SCANC field descriptions (continued)

Field	Description
5 AMCLKDIV	Active mode clock divider 0 Divider set to 1 1 Divider set to 2048
4–3 AMCLKS	Active mode clock source 00 Bus Clock 01 MCGIRCLK 10 OSCERCLK 11 Not valid
2–0 AMPSC	Active mode prescaler 000 Input clock source divided by 1 001 Input clock source divided by 2 010 Input clock source divided by 4 011 Input clock source divided by 8 100 Input clock source divided by 16 101 Input clock source divided by 32 110 Input clock source divided by 64 111 Input clock source divided by 128

51.6.3 Pin enable register (TSIx_PEN)

NOTE

Do not change PEN when GENCS[TSIEN] is set.

NOTE

All PEN bits can be read at any time, but must not be written while GENCS[SCNIP] is set.

Addresses: TSi0_PEN is 4004_5000h base + 8h offset = 4004_5008h

Bit	31	30	29	28	27	26	25	24	23	22	21	20	19	18	17	16	15	14	13	12	11	10	9	8	7	6	5	4	3	2	1	0			
R	0												LPSP				PEN15	PEN14	PEN13	PEN12	PEN11	PEN10	PEN9	PEN8	PEN7	PEN6	PEN5	PEN4	PEN3	PEN2	PEN1	PEN0			
W	0												0				0	0	0	0	0	0	0	0	0	0	0	0	0	0	0	0	0	0	0
Reset	0	0	0	0	0	0	0	0	0	0	0	0	0	0	0	0	0	0	0	0	0	0	0	0	0	0	0	0	0	0	0	0	0		

TSIx_PEN field descriptions

Field	Description
31–20 Reserved	This read-only field is reserved and always has the value zero.
19–16 LPSP	Low-power scan pin

Table continues on the next page...

TSIx_PEN field descriptions (continued)

Field	Description
	Selects which input is active in low-power mode. 0000 TSI_IN[0] is active in low power mode 0001 TSI_IN[1] is active in low power mode 0010 TSI_IN[2] is active in low power mode 0011 TSI_IN[3] is active in low power mode 0100 TSI_IN[4] is active in low power mode 0101 TSI_IN[5] is active in low power mode 0110 TSI_IN[6] is active in low power mode 0111 TSI_IN[7] is active in low power mode 1000 TSI_IN[8] is active in low power mode 1001 TSI_IN[9] is active in low power mode 1010 TSI_IN[10] is active in low power mode 1011 TSI_IN[11] is active in low power mode 1100 TSI_IN[12] is active in low power mode 1101 TSI_IN[13] is active in low power mode 1110 TSI_IN[14] is active in low power mode 1111 TSI_IN[15] is active in low power mode
15 PEN15	TSI pin 15 enable 0 The corresponding pin is not used by TSI 1 The corresponding pin is used by TSI
14 PEN14	TSI pin 14 enable 0 The corresponding pin is not used by TSI 1 The corresponding pin is used by TSI
13 PEN13	TSI pin 13 enable 0 The corresponding pin is not used by TSI 1 The corresponding pin is used by TSI
12 PEN12	TSI pin 12 enable 0 The corresponding pin is not used by TSI 1 The corresponding pin is used by TSI
11 PEN11	TSI pin 11 enable 0 The corresponding pin is not used by TSI 1 The corresponding pin is used by TSI
10 PEN10	TSI pin 10 enable 0 The corresponding pin is not used by TSI 1 The corresponding pin is used by TSI
9 PEN9	TSI pin 9 enable 0 The corresponding pin is not used by TSI 1 The corresponding pin is used by TSI

Table continues on the next page...

TSIx_PEN field descriptions (continued)

Field	Description
8 PEN8	<p>TSI pin 8 enable</p> <p>0 The corresponding pin is not used by TSI 1 The corresponding pin is used by TSI</p>
7 PEN7	<p>TSI pin 7 enable</p> <p>0 The corresponding pin is not used by TSI 1 The corresponding pin is used by TSI</p>
6 PEN6	<p>TSI pin 6 enable</p> <p>0 The corresponding pin is not used by TSI 1 The corresponding pin is used by TSI</p>
5 PEN5	<p>TSI pin 5 enable</p> <p>0 The corresponding pin is not used by TSI 1 The corresponding pin is used by TSI</p>
4 PEN4	<p>TSI pin 4 enable</p> <p>0 The corresponding pin is not used by TSI 1 The corresponding pin is used by TSI</p>
3 PEN3	<p>TSI pin 3 enable</p> <p>0 The corresponding pin is not used by TSI 1 The corresponding pin is used by TSI</p>
2 PEN2	<p>TSI pin 2 enable</p> <p>0 The corresponding pin is not used by TSI 1 The corresponding pin is used by TSI</p>
1 PEN1	<p>TSI pin 1 enable</p> <p>0 The corresponding pin is not used by TSI 1 The corresponding pin is used by TSI</p>
0 PEN0	<p>TSI pin 0 enable</p> <p>0 The corresponding pin is not used by TSI 1 The corresponding pin is used by TSI</p>

51.6.4 Status Register (TSIx_STATUS)

Addresses: TSI0_STATUS is 4004_5000h base + Ch offset = 4004_500Ch

Bit	31	30	29	28	27	26	25	24	23	22	21	20	19	18	17	16
R	ERROF15	ERROF14	ERROF13	ERROF12	ERROF11	ERROF10	ERROF9	ERROF8	ERROF7	ERROF6	ERROF5	ERROF4	ERROF3	ERROF2	ERROF1	ERROF0
W	w1c	w1c	w1c	w1c	w1c	w1c	w1c	w1c	w1c	w1c	w1c	w1c	w1c	w1c	w1c	w1c
Reset	0	0	0	0	0	0	0	0	0	0	0	0	0	0	0	0
Bit	15	14	13	12	11	10	9	8	7	6	5	4	3	2	1	0
R	ORNGF15	ORNGF14	ORNGF13	ORNGF12	ORNGF11	ORNGF10	ORNGF9	ORNGF8	ORNGF7	ORNGF6	ORNGF5	ORNGF4	ORNGF3	ORNGF2	ORNGF1	ORNGF0
W	w1c	w1c	w1c	w1c	w1c	w1c	w1c	w1c	w1c	w1c	w1c	w1c	w1c	w1c	w1c	w1c
Reset	0	0	0	0	0	0	0	0	0	0	0	0	0	0	0	0

TSIx_STATUS field descriptions

Field	Description
31 ERROF15	TouchSensing Error Flag 15 This bit indicates when the corresponding electrode is shorted to VDD or VSS. If the GENCS[ERIE] bit is set, an error interrupt is generated. Write a one to clear this bit.
30 ERROF14	TouchSensing Error Flag 14 This bit indicates when the corresponding electrode is shorted to VDD or VSS. If the GENCS[ERIE] bit is set, an error interrupt is generated. Write a one to clear this bit.
29 ERROF13	TouchSensing Error Flag 13 This bit indicates when the corresponding electrode is shorted to VDD or VSS. If the GENCS[ERIE] bit is set, an error interrupt is generated. Write a one to clear this bit.
28 ERROF12	TouchSensing Error Flag 12 This bit indicates when the corresponding electrode is shorted to VDD or VSS. If the GENCS[ERIE] bit is set, an error interrupt is generated. Write a one to clear this bit.
27 ERROF11	TouchSensing Error Flag 11 This bit indicates when the corresponding electrode is shorted to VDD or VSS. If the GENCS[ERIE] bit is set, an error interrupt is generated. Write a one to clear this bit.
26 ERROF10	TouchSensing Error Flag 10

Table continues on the next page...

TSIx_STATUS field descriptions (continued)

Field	Description
	This bit indicates when the corresponding electrode is shorted to VDD or VSS. If the GENCS[ERIE] bit is set, an error interrupt is generated. Write a one to clear this bit.
25 ERROF9	TouchSensing Error Flag 9 This bit indicates when the corresponding electrode is shorted to VDD or VSS. If the GENCS[ERIE] bit is set, an error interrupt is generated. Write a one to clear this bit.
24 ERROF8	TouchSensing Error Flag 8 This bit indicates when the corresponding electrode is shorted to VDD or VSS. If the GENCS[ERIE] bit is set, an error interrupt is generated. Write a one to clear this bit.
23 ERROF7	TouchSensing Error Flag 7 This bit indicates when the corresponding electrode is shorted to VDD or VSS. If the GENCS[ERIE] bit is set, an error interrupt is generated. Write a one to clear this bit.
22 ERROF6	TouchSensing Error Flag 6 This bit indicates when the corresponding electrode is shorted to VDD or VSS. If the GENCS[ERIE] bit is set, an error interrupt is generated. Write a one to clear this bit.
21 ERROF5	TouchSensing Error Flag 5 This bit indicates when the corresponding electrode is shorted to VDD or VSS. If the GENCS[ERIE] bit is set, an error interrupt is generated. Write a one to clear this bit.
20 ERROF4	TouchSensing Error Flag 4 This bit indicates when the corresponding electrode is shorted to VDD or VSS. If the GENCS[ERIE] bit is set, an error interrupt is generated. Write a one to clear this bit.
19 ERROF3	TouchSensing Error Flag 3 This bit indicates when the corresponding electrode is shorted to VDD or VSS. If the GENCS[ERIE] bit is set, an error interrupt is generated. Write a one to clear this bit.
18 ERROF2	TouchSensing Error Flag 2 This bit indicates when the corresponding electrode is shorted to VDD or VSS. If the GENCS[ERIE] bit is set, an error interrupt is generated. Write a one to clear this bit.
17 ERROF1	TouchSensing Error Flag 1 This bit indicates when the corresponding electrode is shorted to VDD or VSS. If the GENCS[ERIE] bit is set, an error interrupt is generated. Write a one to clear this bit.
16 ERROF0	TouchSensing Error Flag 0 This bit indicates when the corresponding electrode is shorted to VDD or VSS. If the GENCS[ERIE] bit is set, an error interrupt is generated. Write a one to clear this bit.
15 ORNGF15	Touch Sensing Electrode Out-of-Range Flag 15 This bit indicates when the corresponding electrode is out of range. If the GENCS[TSEIE] bit is set and the GENCS[ESOR] bit is cleared, an out-of-range interrupt is generated. Write a one to clear this bit.
14 ORNGF14	Touch Sensing Electrode Out-of-Range Flag 14

Table continues on the next page...

TSIx_STATUS field descriptions (continued)

Field	Description
	This bit indicates when the corresponding electrode is out of range. If the GENCS[TSSIIE] bit is set and the GENCS[ESOR] bit is cleared, an out-of-range interrupt is generated. Write a one to clear this bit.
13 ORNGF13	Touch Sensing Electrode Out-of-Range Flag 13 This bit indicates when the corresponding electrode is out of range. If the GENCS[TSSIIE] bit is set and the GENCS[ESOR] bit is cleared, an out-of-range interrupt is generated. Write a one to clear this bit.
12 ORNGF12	Touch Sensing Electrode Out-of-Range Flag 12 This bit indicates when the corresponding electrode is out of range. If the GENCS[TSSIIE] bit is set and the GENCS[ESOR] bit is cleared, an out-of-range interrupt is generated. Write a one to clear this bit.
11 ORNGF11	Touch Sensing Electrode Out-of-Range Flag 11 This bit indicates when the corresponding electrode is out of range. If the GENCS[TSSIIE] bit is set and the GENCS[ESOR] bit is cleared, an out-of-range interrupt is generated. Write a one to clear this bit.
10 ORNGF10	Touch Sensing Electrode Out-of-Range Flag 10 This bit indicates when the corresponding electrode is out of range. If the GENCS[TSSIIE] bit is set and the GENCS[ESOR] bit is cleared, an out-of-range interrupt is generated. Write a one to clear this bit.
9 ORNGF9	Touch Sensing Electrode Out-of-Range Flag 9 This bit indicates when the corresponding electrode is out of range. If the GENCS[TSSIIE] bit is set and the GENCS[ESOR] bit is cleared, an out-of-range interrupt is generated. Write a one to clear this bit.
8 ORNGF8	Touch Sensing Electrode Out-of-Range Flag 8 This bit indicates when the corresponding electrode is out of range. If the GENCS[TSSIIE] bit is set and the GENCS[ESOR] bit is cleared, an out-of-range interrupt is generated. Write a one to clear this bit.
7 ORNGF7	Touch Sensing Electrode Out-of-Range Flag 7 This bit indicates when the corresponding electrode is out of range. If the GENCS[TSSIIE] bit is set and the GENCS[ESOR] bit is cleared, an out-of-range interrupt is generated. Write a one to clear this bit.
6 ORNGF6	Touch Sensing Electrode Out-of-Range Flag 6 This bit indicates when the corresponding electrode is out of range. If the GENCS[TSSIIE] bit is set and the GENCS[ESOR] bit is cleared, an out-of-range interrupt is generated. Write a one to clear this bit.
5 ORNGF5	Touch Sensing Electrode Out-of-Range Flag 5 This bit indicates when the corresponding electrode is out of range. If the GENCS[TSSIIE] bit is set and the GENCS[ESOR] bit is cleared, an out-of-range interrupt is generated. Write a one to clear this bit.
4 ORNGF4	Touch Sensing Electrode Out-of-Range Flag 4 This bit indicates when the corresponding electrode is out of range. If the GENCS[TSSIIE] bit is set and the GENCS[ESOR] bit is cleared, an out-of-range interrupt is generated. Write a one to clear this bit.
3 ORNGF3	Touch Sensing Electrode Out-of-Range Flag 3 This bit indicates when the corresponding electrode is out of range. If the GENCS[TSSIIE] bit is set and the GENCS[ESOR] bit is cleared, an out-of-range interrupt is generated. Write a one to clear this bit.
2 ORNGF2	Touch Sensing Electrode Out-of-Range Flag 2

Table continues on the next page...

TSIx_STATUS field descriptions (continued)

Field	Description
	This bit indicates when the corresponding electrode is out of range. If the GENCS[TSIIE] bit is set and the GENCS[ESOR] bit is cleared, an out-of-range interrupt is generated. Write a one to clear this bit.
1 ORNGF1	Touch Sensing Electrode Out-of-Range Flag 1
0 ORNGF0	Touch Sensing Electrode Out-of-Range Flag 0 This bit indicates when the corresponding electrode is out of range. If the GENCS[TSIIE] bit is set and the GENCS[ESOR] bit is cleared, an out-of-range interrupt is generated. Write a one to clear this bit.

51.6.5 Counter Register (TSIx_CNTR)

Addresses: TSI0_CNTR1 is 4004_5000h base + 100h offset = 4004_5100h
 TSI0_CNTR3 is 4004_5000h base + 104h offset = 4004_5104h
 TSI0_CNTR5 is 4004_5000h base + 108h offset = 4004_5108h
 TSI0_CNTR7 is 4004_5000h base + 10Ch offset = 4004_510Ch
 TSI0_CNTR9 is 4004_5000h base + 110h offset = 4004_5110h
 TSI0_CNTR11 is 4004_5000h base + 114h offset = 4004_5114h
 TSI0_CNTR13 is 4004_5000h base + 118h offset = 4004_5118h
 TSI0_CNTR15 is 4004_5000h base + 11Ch offset = 4004_511Ch

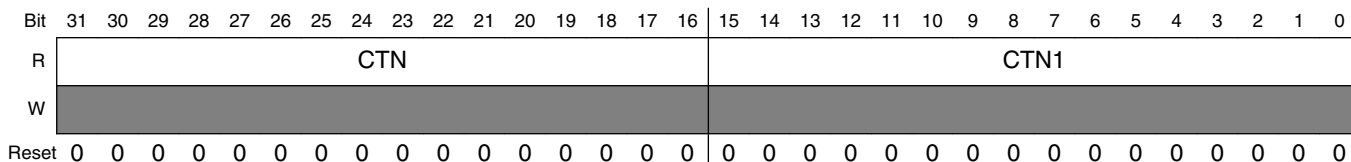

TSIx_CNTRn field descriptions

Field	Description
31–16 CTN	TouchSensing channel <i>n</i> counter value
15–0 CTN1	TouchSensing channel <i>n-1</i> counter value

51.6.6 Channel n threshold register (TSIx_THRESHLD)

All THRESHLD bits can be read at any time, but must not be written while GENCS[SCNIP] is set.

Addresses: 4004_5000h base + 120h offset + (4d × n), where n = 0d to 15d

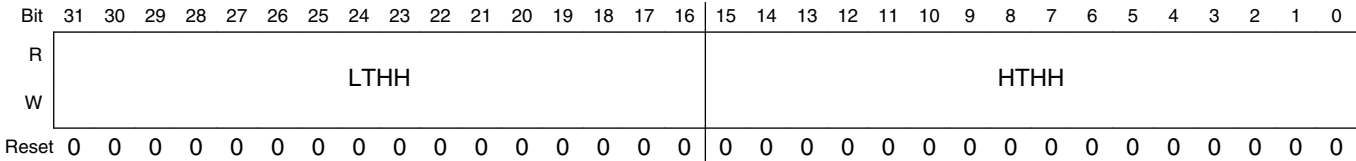

TSIx_THRESHLDn field descriptions

Field	Description
31–16 LTHH	Low threshold value
15–0 HTHH	High threshold value

51.7 Functional descriptions

This section provides functional description of the TSI module.

51.7.1 Capacitance measurement

The electrode pin capacitance measurement uses a dual oscillator approach. The TSI electrode oscillator has its frequency dependable on the external electrode capacitance and the TSI module configuration. After going to a configurable prescaler, the TSI electrode oscillator signal goes to the input of the modulo counter. The time for the external electrode oscillations is measured using the TSI reference oscillator. The measured electrode capacitance is directly proportional to this time.

51.7.1.1 TSI electrode oscillator

The TSI electrode oscillator circuit is illustrated in the following figure. A configurable constant current source is used to charge and discharge the external electrode capacitance. A buffer hysteresis defines the oscillator delta voltage. The delta voltage defines the margin of high and low voltage which are the reference input of the comparator in different time.

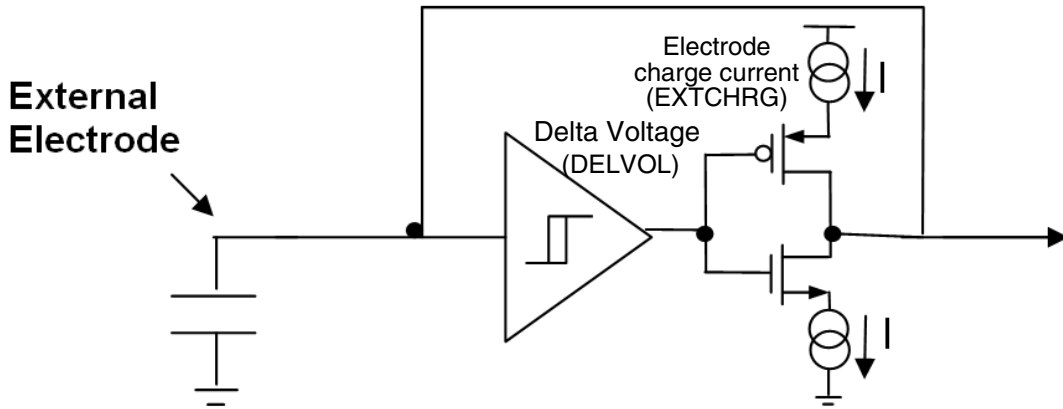

Figure 51-64. TSI electrode oscillator circuit

The current source applied to the pad capacitance is 5-bit binary controlled by the SCANC[EXTCHRG]. The hysteresis delta voltage is also configurable and is 3-bit binary controlled by the SCANC[DELVOL]. The figure below shows the voltage amplitude waveform of the electrode capacitance charging and discharging with a programmable current.

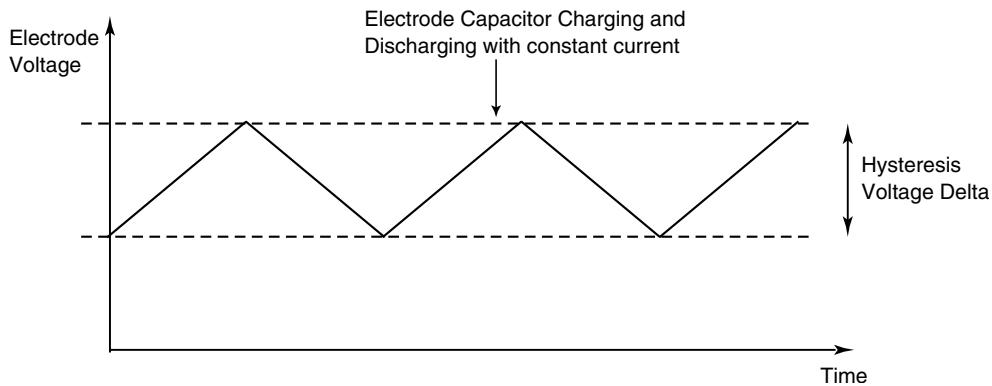

Figure 51-65. TSI electrode oscillator chart

The oscillator frequency is given by the following equation:

$$F_{elec} = \frac{I}{2 * C_{elec} * \Delta V}$$

Figure 51-66. Equation 1: TSI electrode oscillator frequency

Where:

I: constant current

C_{elec}: electrode capacitance

ΔV: Hysteresis delta voltage

So by this equation, for example, an electrode with $C_{elec} = 20 \text{ pF}$, with a current source of $I = 16 \text{ }\mu\text{A}$ and $\Delta V = 600 \text{ mV}$ will have the following oscillation frequency:

$$F_{elec} = \frac{16 \text{ }\mu\text{A}}{2 * 20\text{pF} * 600\text{mV}} = 0.67\text{MHz}$$

Figure 51-67. Equation 2: TSI electrode oscillator frequency

The current source and hysteresis delta voltage are used to accommodate the TSI electrode oscillator frequency with different electrode capacitance sizes.

51.7.1.2 Electrode oscillator and counter control

The TSI oscillator frequency signal goes through a prescaler defined by the GENCS[PS] and then enters a counter. The bit field GENCS[NSCN] defines the number of scans for each external electrode.

The pin capacitance sampling time is given by the time the module counter takes to go from zero to its maximum value, defined by NSCN. The electrode sample time is expressed by the following equation:

$$T_{cap_samp} = \frac{PS * NSCN}{F_{elec}}$$

Using Equation 1.

$$T_{cap_samp} = \frac{2 * PS * NSCN * C_{elec} * \Delta V}{I}$$

Figure 51-68. Equation 3: Electrode sampling time

Where:

PS: prescaler value

NSCN: number of scan

I: constant current

C_{elec} : electrode capacitance

ΔV : Hysteresis delta voltage

By this equation, an electrode with $C = 20 \text{ pF}$, with a current source of $I = 16 \text{ }\mu\text{A}$ and $\Delta V = 600 \text{ mV}$, $PS = 2$ and $NSCN = 16$ will have the following sampling time:

$$T_{cap_samp} = \frac{2 * 2 * 16 * 20pF * 600mV}{16\mu A} = 48\mu s$$

51.7.1.3 TSI reference oscillator

The TSI reference oscillator has the same topology of the TSI electrode oscillator. The TSI reference oscillator instead of using an external capacitor for the electrode oscillator has an internal reference capacitor which can be programmable. The SCANC[CAPTRM] defines the internal reference capacitor trimming value *.

The TSI reference oscillator share the same voltage hysteresis levels defined with the SCANC[DELVOL] and has an independent programmable current source controlled by the SCANC[REFCHRG].

* The reference oscillator frequency is given by the following equation:

$$F_{ref_osc} = \frac{I_{ref}}{2 * C_{ref} * \Delta V}$$

Figure 51-69. Equation 4: TSI reference oscillator frequency

Where:

C_{ref}: Internal reference capacitor

I_{ref}: Reference oscillator current source

ΔV : Hysteresis delta voltage

Considering C_{ref} = 1.0 pF, I_{ref} = 12 μA and ΔV = 600 mV, follows

$$F_{ref_osc} = \frac{12\mu A}{2 * 1.0pF * 600mV} = 10.0MHz$$

51.7.2 TSI measurement result

The capacitance measurement result is defined by the number of TSI reference oscillator periods during the sample time and is stored in the TSICHnCNT register.

$$TSICHnCNT = T_{cap_samp} * F_{ref_osc}$$

Using Equation 2 and Equation 1 follows:

$$\text{TSICHnCNT} = \frac{I_{\text{ref}} * PS * NSCN}{C_{\text{ref}} * I_{\text{ref}}} * C_{\text{elec}}$$

Figure 51-70. Equation 5: Capacitance result value

In the example where $F_{\text{ref_osc}} = 10.0\text{MHz}$ and $T_{\text{cap_samp}} = 48 \mu\text{s}$, $\text{TSICHnCNT} = 480$

51.7.3 Electrode scan unit

This section describes the functionality of the electrode scan unit. It is responsible for triggering the start of the active electrode scan.

The touch sense input module needs to periodically scan all active electrodes to determine if a touch event has occurred. The electrode scan unit has two independent scan periods, one for TSI active mode and the other for TSI low power mode. This independent control allows the application to configure longer scan period during low power mode, so contributing to smaller average power consumption. The TSI, in low power mode, has the capability to wake the CPU upon an electrode capacitance change. When the CPU wakes, the TSI enters active mode, and produces a shorter scan period for a faster response and more robust touch detection. Apart from the periodical mode, the electrode scan unit also allows software triggering of the electrode scans. This feature is very useful for initialization of the touch application to detect the initial electrode capacitances. This module generates configurable end-of-scan interrupt to indicate the application that all electrodes were scanned. If a new electrode scan is started while the previous one is still in progress, an overrun error flag is generated, TSI continues the previous scan sequence and the latest trigger is ignored.

51.7.3.1 Active electrodes

The electrode scan unit starts the capacitance measurement of all active electrodes. Each electrode pin should be activated by writing a 1 to the respective PEN[PEN] 16-bit field.

Once an electrode scan is triggered, the electrode scan unit controls the scanning of all the active electrodes sequentially. It starts the scanning of the electrode pin TSI_IN[0] and goes sequentially scanning until it reaches the electrode pin TSI_IN[15]. The electrode pin that does not have its bit (PEN[PEN]) enabled is not scanned and is skipped.

Only one electrode pin is functional in the low power mode scan and it's defined by the PEN[LPSP]. In low power scan mode, the configuration of PEN[PEN] bits is ignored.

51.7.3.2 Scan trigger

The scan trigger can be set to periodical scan or software trigger. The bit GENCS[STM] determines the TSI scan trigger mode. If STM = 1 the trigger mode is selected as continuous. If STM = 0, the software trigger mode is selected. In periodic mode the scan trigger is generated automatically by the electrode scan unit.

NOTE

It takes some time (less than 40 μ s) for TSI oscillators to be stable in software trigger mode and periodical scan mode. In the first scan process, TSI_GENCS[SCNIP] lags some time before a valid after trigger happens.

51.7.3.3 Software trigger mode

The software trigger scan is started by writing 1 to the bit GENCS[SWTS]. A single scan of all active electrodes is performed. The software trigger scan only can be initiated by the GENCS[SWTS] bit if the STM = 0. If STM = 1, any write in the GENCS[SWTS] bit is ignored.

51.7.3.4 Periodic scan control

The electrode scan unit operates both in TSI active mode and TSI low power mode. It has a separate scan period control for each one of these modes. It allows the application to controls the trade-off of the scan frequency and the average TSI module power consumption.

51.7.3.4.1 Active mode periodic scan

In active mode periodic scan the scan following clocks can be selected: BUS_CLK, MCGIRCLK and OSCERCLK. The bit field SCANC[AMCLKS] selects the TSI clock source for the active mode scan. The scan period is determined by the SCANC[SMOD] value. SMOD is the modulo of the counter that determines the scan period.

The following figure presents the scan sequence performed by the TSI module. Every active electrode is scanned sequentially, starting with the TSI_IN[0] and ending with the TSI_IN[15] pin, if they are active.

When the electrode scan unit starts a scan sequence, all the active electrodes will be scanned sequentially where each electrode has the scanned time defined by GENCS[NSCN]. The counter value is the sum of the total scan times of that electrode.

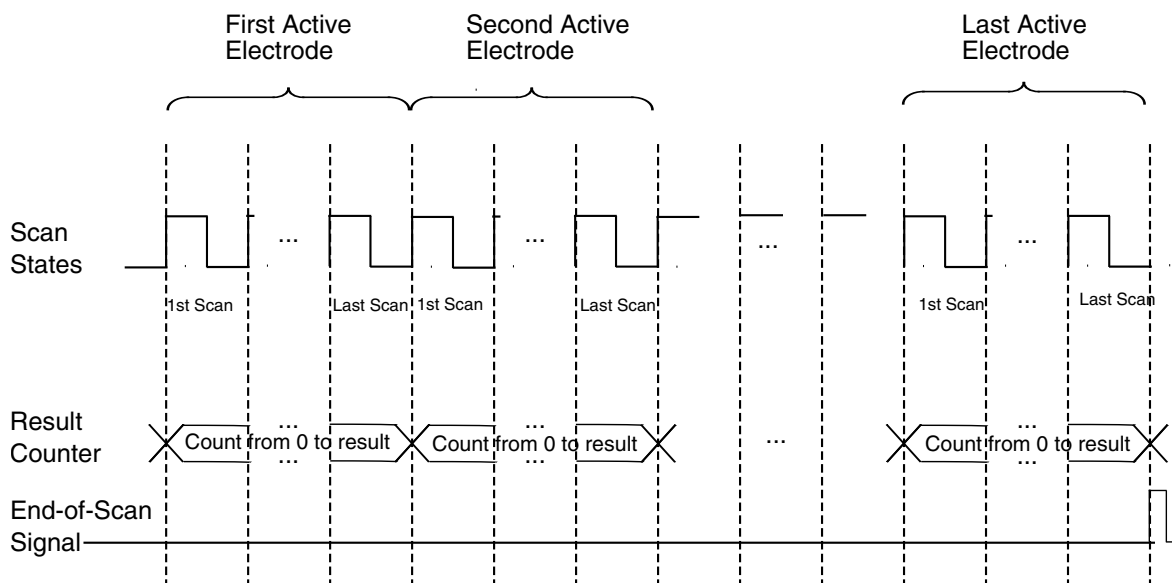

Figure 51-71. Scan sequence

51.7.3.4.2 Low power mode scan

In low power periodic scan, the scan period is defined by the 4-bit binary `GENCS[LPSCNITV]`. The TSI module is enabled in low power modes only if the bit `GENCS[STPE]` is 1.

Only one electrode pin is functional in the low power mode scan and its defined by the bit-field `PEN[LPSP]`.

51.7.3.4.3 End-of-scan interrupt

Once all the active electrodes are scanned, TSI scan unit will assert the end-of-scan flag. Upon the end-of-scan event, each electrode conversion result will be loaded to the corresponding counter register, compared with each threshold to determine if its value is out of range specified by the threshold registers, and if the counter value is stuck at extreme values (0x0000 or 0xFFFF), the corresponding error flag will also assert.

The electrode scan unit sets the EOSF flag in the `GENCS` registers once all the active electrode scan finishes. The EOSF flag generates an end-of-scan interrupt request if it is enabled. The interrupt is asserted if enabled by `GENCS[TSIIE]` and `GENCS[ESOR]` bits.

The `GENCS[EOSF]` indicates that all active electrode scans are finished and the respective capacitance results are in the `TSICHnCNT` registers. The `GENCS[EOSF]` is cleared by writing one to it.

It is worthy to note that, since all the possible flags are asserted upon the end of scan event, in TSI interrupt service routine, the end-of-scan flag will be always set until the software clears it.

51.7.3.4.4 Over-run interrupt

If an electrode scan is in progress and there is a scan trigger, the electrode scan unit generates an over-run error by asserting the GENCS[OVRF]. If the TSI error interrupt is active by setting the GENCS[ERIE] bit a interrupt request is asserted. The OVRF flag is cleared by writing 1 to it.

51.7.4 Touch detection unit

The touch detection unit is responsible to detect electrode capacitance changes. It also detects the occurrence of error with the electrode in case the capacitance result is 0x0000 or 0xFFFF. The errors can be caused by the electrode pin shorted to V_{DD} or V_{SS} or by electrode capacitances out of the configuration range of the TSI module.

51.7.4.1 Capacitance change threshold

Each TSI pin has its result register TSICHnCNT. At the end of each electrode conversion the touch detection unit compares if the TSICHnCNT result value is inside a configurable range. The comparison range is defined individually for each TSI pin by the following registers, TSICHnHTH, the upper threshold value and TSICHnLTH, the lower threshold value. If the TSICHnCNT happens to be out of the range defined by TSICHnLTH and TSICHnHTH the GENCS[OUTRGF] flag is set. Also the corresponding bit STATUS[ORNGFx] is set indicating which electrode pins happened to have their result register out-of- range.

To clear the GENCS[OUTRGF] write 1 to it.

51.7.4.1.1 Out-of-range interrupt

The GENCS[OUTRGF] flag generates a TSI interrupt request if the GENCS[TSIIE] bit is set and the GENCS[ESOR] bit is cleared. With this configuration, after the end-of-electrode scan, the TSI interrupt is only requested if there is a capacitance change. The capacitance change is detected when the result register gets outside the window defined by the TSI_THRESHLD register. If the electrodes capacitance does not vary, the TSI does not interrupt the CPU.

When GENCS[OUTRGF] flag is asserted, it is requested the software to poll which specific electrode is out of range by reading the status from STATUS register, clearing the corresponding electrodes flags will also clear the out-of-range flag in GENCS[OUTRGF].

51.7.4.2 Error interrupt

The GENCS[EXTERF] is set in the case the capacitance result registers, TSICHnCNT, of a TSI pin is either 0 or 0xFFFF, the two possible extreme values. The EXTERF flag generates a TSI Error Interrupt request if the GENCS[ERIE] bit is set.

When the GENCS[EXTERF] is set, the registers STATUS register indicates which TSI pins have the error condition by setting the correspondent STATUS[ERRORx] bit.

Before clearing the error flags, users need to check which channel is problematic and then clear the corresponding flags in STATUS register.

51.8 Application information

After enabling the TSI module for the first time, it is highly recommended to calibrate all the enabled channels by setting proper high and low threshold value for each active channel. All the channel dedicated counter values can be read from each counter value registers. The software suite can then adjust the threshold based on these values.

Follow proper PCB layout guidelines for board design on electrode shapes, sizes, routes, etc. Visit <http://www.freescale.com/touch> for application notes and reference designs.

51.8.1 TSI module sensitivity

The TSI module sensitivity is defined by the increment in the two 16-bit TSICHnCNT result registers caused by a reference capacitor value delta in the electrode pin capacitance.

It is given by the following equation:

$$TSI_{sensitivity} = \frac{I_{ref} * PS * NSCN}{C_{ref} * I}$$

For the example provided, $I_{ref} = 2 \mu A$, $PS = 2$; $NSCN = 16$, $C_{ref} = 1.0 \text{ pF}$ and $I = 1 \mu A$, the $TSI_{sensitivity} = 64 \text{ count/pF}$



Chapter 52

LCD Controller (SLCD)

52.1 Introduction

NOTE

For the chip-specific implementation details of this module's instances see the chip configuration chapter.

The SLCD module is a CMOS charge pump voltage inverter that is designed for low-voltage and low-power operation. The SLCD module is designed to generate the appropriate waveforms to drive multiplexed numeric, alpha-numeric, or custom segment LCD panels. Depending on hardware and software configuration, the LCD panels can be either 3 V or 5 V. The LCD controller also has several timing and control settings that can be software configured depending on the application's requirements. Timing and control consists of registers and control logic for:

- LCD frame frequency
- Duty cycle select
- Frontplane/backplane select and enable
- Blink modes and frequency
- Operation in low-power modes

52.1.1 Features

The LCD controller features include:

- LCD waveforms functional in all low-power modes
- 64 LCD pins with selectable frontplane/backplane configuration

- Generate up to 63 frontplane signals
- Generate up to 8 backplanes signals
- Programmable LCD frame frequency
- Programmable blink modes and frequency
 - All segments blank during blink period
 - Alternate display for each LCD segment in x4 or less mode
 - Blink operation in low-power modes
- Programmable LCD duty cycle from static to 1/8
- Programmable LCD power supply switch, making it an ideal solution for battery-powered and board-level applications
 - Charge pump requires only four external capacitors
 - Internal LCD power using V_{DD}
 - Internal V_{IREG} regulated power supply option for 3 V or 5 V LCD glass
 - External V_{LL3} power supply option
- Internal regulated voltage source with a 4-bit trim register to apply contrast control
- Integrated charge pump for generating LCD bias voltages
 - Hardware configurable to drive 3 V or 5 V LCD panels
 - On-chip generation of bias voltages
- Waveform storage registers (WF)
- Low power consumption in standby modes
- Backplane reassignment to assist in vertical scrolling on dot-matrix displays
- Software configurable LCD frame frequency interrupt
- Support for segment fault detection

52.1.2 Modes of operation

The LCD controller supports the following operating modes:

Table 52-1. LCD controller operation modes

Mode	LCD behavior
Run	The LCD controller can operate an LCD panel. The LCD controller continues displaying the current LCD panel contents based on the WF registers.
Wait	Depending on the configuration, the LCD controller can operate an LCD panel in Wait mode. If LCDWAIT = 1, the LCD controller clock generation is turned off and the LCD controller enters a power-conservation state and is disabled. If LCDWAIT = 0, the LCD controller can operate an LCD panel in Wait mode, and the LCD controller continues displaying the current LCD panel contents based on the WF registers. In Wait mode, the LCD frame interrupt can cause the MCU to exit Wait.
Stop	Depending on the state of the LCDSTP bit, the LCD controller can operate an LCD panel in Stop mode. If LCDSTP = 1, LCD controller clock generation is turned off and the LCD controller enters a power conservation state and is disabled. If LCDSTP = 0, the LCD controller can operate an LCD panel in Stop mode, and the LCD controller continues to display the current LCD panel contents based on the LCD operation prior to the Stop event. If the LCD is enabled in Stop mode, the selected LCD clock source must be enabled to operate in Stop mode. The LCD frame interrupt does not cause the MCU to exit Stop mode.
VLPR	LCD controller behavior is the same as in Run mode.
VLPW	LCD controller behavior is the same as in Wait mode.
VLPS	LCD controller behavior is the same as in Stop mode.
LLS	LCD controller behavior is the same as in Stop mode.
VLLS3	LCD controller behavior is the same as in Stop mode.
VLLS2	LCD controller behavior is the same as in Stop mode.
VLLS1	LCD controller behavior is the same as in Stop mode.

NOTE

LCD End of Frame wakeup is not supported in LLS and VLLSx modes.

NOTE

The clock source and power modes are chip-specific. For the clock source and power-mode assignments, see the chapter that describes how modules are configured.

52.1.3 Block diagram

The following figure shows block diagram of the LCD controller.

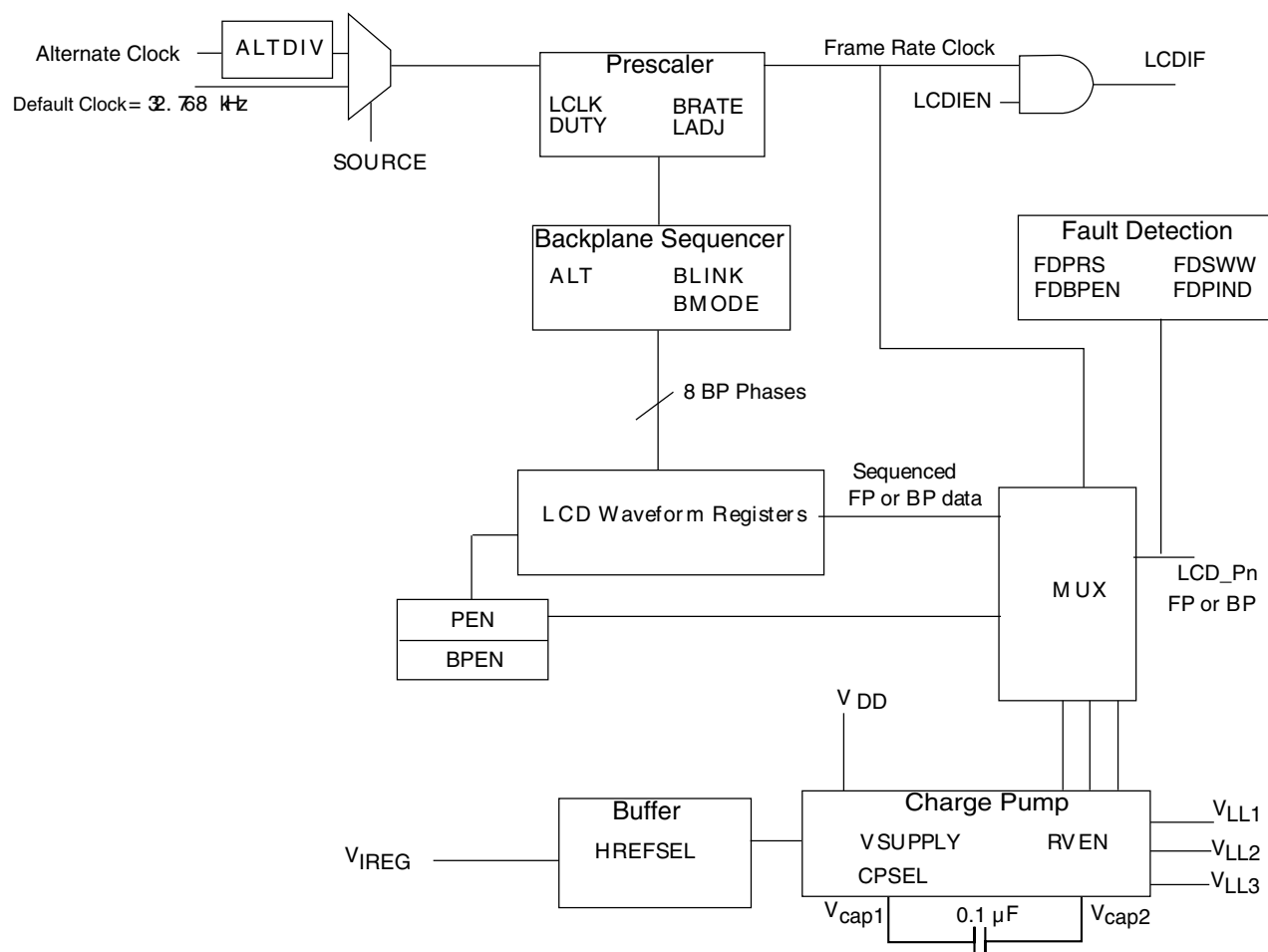

Figure 52-1. LCD controller block diagram

52.2 LCD Signal Descriptions

The LCD controller has several external pins dedicated to power supply and LCD frontplane/backplane signaling. The LCD controller can be configured to support up to eight backplane signals. This table lists and describes the LCD external signals or pins.

Table 52-2. LCD Signal Descriptions

Signal	Description	I/O
LCD_P[63:0] . 64 LCD frontplane/backplane	Configurable frontplane/backplane driver that connects directly to the display LCD_P[63:0] can operate as GPIO pins	O
V _{LL1} , V _{LL2} , V _{LL3} . LCD bias voltages	LCD bias voltages	I/O
V _{cap1} , V _{cap2} . LCD charge pump capacitance	Charge pump capacitor pins	O

52.2.1 LCD_P[63:0]

When LCD functionality is enabled by the PEN[63:0] bits in the PEN registers, the corresponding LCD_P[63:0] pin generates a frontplane or backplane waveform depending on the configuration of the backplane-enable bit field (BPEN[63:0]).

52.2.2 V_{LL1} , V_{LL2} , V_{LL3}

V_{LL1} , V_{LL2} , and V_{LL3} are bias voltages for the LCD controller driver waveforms that can be internally generated using the internal charge pump (when enabled). When using the LCD charge pump, CPSEL = 1, a 0.1 μ F capacitor should be placed from V_{LLx} to ground. The charge pump can also be configured to accept V_{LL3} as an input and generate V_{LL1} and V_{LL2} for 3 V glass operation. V_{LL3} should never be connected to a voltage other than V_{DD} . Refer to VSUPPLY[1:0] bits explanation.

52.2.3 V_{cap1} , V_{cap2}

The charge pump capacitor is used to transfer charge from the input supply to the regulated output. Use a ceramic capacitor. A 0.1 μ F capacitor should be placed between these two pins.

52.3 Memory map and register definition

The total address for each register is the sum of the base address for the LCD controller and the address offset for each register.

This section consists of register descriptions. Each description includes a standard register diagram. Details of register bit and field function follow the register diagrams, in bit order.

LCD memory map

Absolute address (hex)	Register name	Width (in bits)	Access	Reset value	Section/page
400B_E000	LCD general control register (LCD_GCR)	32	R/W	0835_0003h	52.3.1/1555

Table continues on the next page...

LCD memory map (continued)

Absolute address (hex)	Register name	Width (in bits)	Access	Reset value	Section/page
400B_E004	LCD auxiliary register (LCD_AR)	32	R/W	0000_0000h	52.3.2/1559
400B_E008	LCD fault detect control register (LCD_FDCR)	32	R/W	0000_0000h	52.3.3/1561
400B_E00C	LCD fault detect status register (LCD_FDSR)	32	R/W	0000_0000h	52.3.4/1562
400B_E010	LCD pin enable register (LCD_PENL)	32	R/W	0000_0000h	52.3.5/1563
400B_E014	LCD pin enable register (LCD_PENH)	32	R/W	0000_0000h	52.3.5/1563
400B_E018	LCD backplane enable register (LCD_BPENL)	32	R/W	0000_0000h	52.3.6/1564
400B_E01C	LCD backplane enable register (LCD_BPENH)	32	R/W	0000_0000h	52.3.6/1564
400B_E020	LCD waveform register (LCD_WF3TO0)	32	R/W	0000_0000h	52.3.7/1565
400B_E024	LCD waveform register (LCD_WF7TO4)	32	R/W	0000_0000h	52.3.8/1566
400B_E028	LCD waveform register (LCD_WF11TO8)	32	R/W	0000_0000h	52.3.9/1566
400B_E02C	LCD waveform register (LCD_WF15TO12)	32	R/W	0000_0000h	52.3.10/1567
400B_E030	LCD waveform register (LCD_WF19TO16)	32	R/W	0000_0000h	52.3.11/1568
400B_E034	LCD waveform register (LCD_WF23TO20)	32	R/W	0000_0000h	52.3.12/1568
400B_E038	LCD waveform register (LCD_WF27TO24)	32	R/W	0000_0000h	52.3.13/1569
400B_E03C	LCD waveform register (LCD_WF31TO28)	32	R/W	0000_0000h	52.3.14/1570
400B_E040	LCD waveform register (LCD_WF35TO32)	32	R/W	0000_0000h	52.3.15/1570
400B_E044	LCD waveform register (LCD_WF39TO36)	32	R/W	0000_0000h	52.3.16/1571
400B_E048	LCD waveform register (LCD_WF43TO40)	32	R/W	0000_0000h	52.3.17/1572
400B_E04C	LCD waveform register (LCD_WF47TO44)	32	R/W	0000_0000h	52.3.18/1572
400B_E050	LCD waveform register (LCD_WF51TO48)	32	R/W	0000_0000h	52.3.19/1573

Table continues on the next page...

LCD memory map (continued)

Absolute address (hex)	Register name	Width (in bits)	Access	Reset value	Section/page
400B_E054	LCD waveform register (LCD_WF55TO52)	32	R/W	0000_0000h	52.3.20/1573
400B_E058	LCD waveform register (LCD_WF59TO56)	32	R/W	0000_0000h	52.3.21/1574
400B_E05C	LCD waveform register (LCD_WF63TO60)	32	R/W	0000_0000h	52.3.22/1575

52.3.1 LCD general control register (LCD_GCR)

Write: LCDEN anytime. Do not change SOURCE, LCLK, or DUTY while LCDEN = 1. For proper operation, do not modify VSUPPLY[1:0] while the LCDEN bit is asserted. VSUPPLY[1:0] must also be configured according to the external hardware power supply configuration. The regulated voltage can be used to generate a reference signal to the LCD charge pump for 3 V or 5 V LCD operation dependant on the HREFSEL bit.

NOTE

The reset value of this register depends on the reset type:

- POR -- 0x0835_0003

Address: LCD_GCR is 400B_E000h base + 0h offset = 400B_E000h

Bit	31	30	29	28	27	26	25	24	23	22	21	20	19	18	17	16	
R		0												0			
W	RVEN					RVTRIM				CPSEL	HREFSEL	LADJ			0	VSUPPLY	
Reset	0	0	0	0	1	0	0	0	0	0	0	1	1	0	1	0	1
Bit	15	14	13	12	11	10	9	8	7	6	5	4	3	2	1	0	
R					0	0											
W	LCDIEN	FDCIEN	ALTDIV				LCDWAIT	LCDSTP	LCDEN	SOURCE	LCLK			DUTY			
Reset	0	0	0	0	0	0	0	0	0	0	0	0	0	0	1	1	

LCD_GCR field descriptions

Field	Description
31 RVEN	Regulated voltage enable Enables internal voltage regulator. It must have the charge pump enabled.

Table continues on the next page...

LCD_GCR field descriptions (continued)

Field	Description										
	0 Regulated voltage disabled. 1 Regulated voltage enabled.										
30–28 Reserved	Reserved This read-only field is reserved and always has the value zero.										
27–24 RVTRIM	Regulated voltage trim This 4-bit trim register is used to adjust the regulated input. Each bit in the register has equal weight. The regulated input is changed by 1.5% for each count.										
23 CPSEL	Charge pump or resistor bias select Selects the LCD controller charge pump or a resistor network to supply the LCD voltages V_{LL1} , V_{LL2} , and V_{LL3} . 0 LCD charge pump is disabled. Resistor network selected. (The internal 1/3-bias is forced.) 1 LCD charge pump is selected. Resistor network disabled. (The internal 1/3-bias is forced.)										
22 HREFSEL	High reference select When using the V_{IREG} inputs, this bit configures internal circuits to supply V_{LL1} . 0 Divide input, $V_{IREG} = 1.0$ V for 3 V glass. 1 Do not divide the input, $V_{IREG} = 1.67$ V for 5 V glass.										
21–20 LADJ	Load adjust The load adjust bits are used to configure the LCD controller to handle different LCD glass capacitance. <table border="1" style="width: 100%; margin-top: 10px;"> <tr> <td style="width: 50%; vertical-align: top;">For CPSEL = 0</td> <td style="width: 50%; vertical-align: top;">Adjust the resistor bias network for different LCD glass capacitance.</td> </tr> <tr> <td></td> <td>00 — Low Load (LCD glass capacitance 2000 pF or lower).</td> </tr> <tr> <td></td> <td>01 — Low Load (LCD glass capacitance 2000 pF or lower).</td> </tr> <tr> <td></td> <td>10 — High Load (LCD glass capacitance 8000 pF or lower).</td> </tr> <tr> <td></td> <td>11 — High Load (LCD glass capacitance 8000 pF or lower).</td> </tr> </table>	For CPSEL = 0	Adjust the resistor bias network for different LCD glass capacitance.		00 — Low Load (LCD glass capacitance 2000 pF or lower).		01 — Low Load (LCD glass capacitance 2000 pF or lower).		10 — High Load (LCD glass capacitance 8000 pF or lower).		11 — High Load (LCD glass capacitance 8000 pF or lower).
For CPSEL = 0	Adjust the resistor bias network for different LCD glass capacitance.										
	00 — Low Load (LCD glass capacitance 2000 pF or lower).										
	01 — Low Load (LCD glass capacitance 2000 pF or lower).										
	10 — High Load (LCD glass capacitance 8000 pF or lower).										
	11 — High Load (LCD glass capacitance 8000 pF or lower).										

Table continues on the next page...

LCD_GCR field descriptions (continued)

Field	Description
	<p>For CPSEL = 1</p> <ul style="list-style-type: none"> • Adjust the clock source for the charge pump. • Higher loads require higher charge pump clock rates. <p>00 — Fastest clock source for charge pump (LCD glass capacitance 8000 pF or lower).</p> <p>01 — Intermediate clock source for charge pump (LCD glass capacitance 6000 pF or lower).</p> <p>10 — Intermediate clock source for charge pump (LCD glass capacitance 4000 pF or lower).</p> <p>11 — Slowest clock source for charge pump (LCD glass capacitance 2000 pF or lower).</p>
19 Reserved	<p>Reserved</p> <p>This read-only field is reserved and always has the value zero.</p>
18 Reserved	<p>Reserved</p> <p>This field is reserved.</p>
17–16 VSUPPLY	<p>Voltage supply control</p> <p>Configures whether the LCD controller power supply is external or internal. Avoid modifying this bit field while the LCD controller is enabled (for example, LCDEN = 1).</p> <p>00 Drive V_{LL2} internally from V_{DD}.</p> <p>01 Drive V_{LL3} internally from V_{DD}.</p> <p>10 Reserved</p> <p>11 Drive V_{LL3} externally from V_{DD} or drive V_{LL1} internally from V_{IREG}.</p>
15 LCDIEN	<p>LCD frame frequency interrupt enable</p> <p>Enables an LCD interrupt event that coincides with the LCD controller frame frequency.</p> <p>0 No interrupt request is generated by this event.</p> <p>1 When LCDIF bit is set, this event causes an interrupt request.</p>
14 FDCIEN	<p>LCD fault detection complete interrupt enable</p> <p>Enables an LCD interrupt event when fault detection is completed.</p> <p>0 No interrupt request is generated by this event.</p> <p>1 When a fault is detected and FDCF bit is set, this event causes an interrupt request.</p>
13–12 ALTDIV	<p>LCD alternate clock divider</p> <p>This bit is used as a clock divider to divide the alternate clock before it is selected as LCD clock source.</p> <p>0 Divide factor = 1 (No divide)</p> <p>1 Divide factor = 8</p> <p>2 Divide factor = 64</p> <p>3 Divide factor = 512</p>

Table continues on the next page...

LCD_GCR field descriptions (continued)

Field	Description
11 Reserved	Reserved This read-only field is reserved and always has the value zero.
10 Reserved	Reserved This read-only field is reserved and always has the value zero.
9 LCDWAIT	LCD driver, charge pump, resistor bias network, and voltage regulator stop while in Wait mode. 0 Allows the LCD driver, charge pump, resistor bias network, and voltage regulator to continue running during Wait mode. 1 Disables the LCD driver, charge pump, resistor bias network, and voltage regulator when MCU goes into Wait mode.
8 LCDSTP	LCD driver, charge pump, resistor bias network, and voltage regulator while in Stop mode. 0 Allows the LCD driver, charge pump, resistor bias network, and voltage regulator to continue running during Stop mode. 1 Disables the LCD driver, charge pump, resistor bias network, and voltage regulator when MCU goes into Stop mode.
7 LCDEN	LCD driver enable LCDEN starts LCD controller waveform generator. 0 All frontplane and backplane pins are disabled. The LCD controller system is also disabled, and all LCD waveform generation clocks are stopped. V _{LL3} is connected to V _{DD} internally. 1 LCD controller driver system is enabled, and frontplane and backplane waveforms are generated. All LCD pins, LCD_Pn, enabled using the LCD pin enable register, output an LCD driver waveform. The backplane pins output an LCD driver backplane waveform based on the settings of DUTY[2:0]. Charge pump or resistor bias is enabled.
6 SOURCE	LCD clock source select The LCD controller has two possible clock sources. This bit is used to select which clock source is the basis for LCD clock. NOTE: The clock sources are chip-specific. For the clock source assignments, see the chapter that describes how modules are configured. 0 Selects the default clock as the LCD clock source. 1 Selects the alternate clock as the LCD clock source.
5-3 LCLK	LCD clock prescaler Used as a clock divider to generate the LCD controller frame frequency. LCD controller duty-cycle configuration is used to determine the LCD controller frame frequency. LCD controller frame frequency calculations are provided in LCD controller base clock and frame frequency . $\text{LCD controller frame frequency} = \frac{\text{LCD clock}}{(\text{DUTY} + 1) * 8 * (4 + \text{LCLK}[2:0]) * Y}$ <i>where:</i> <ul style="list-style-type: none"> • 30 < LCD clock < 39.063 kHz • Y = 2, 2, 3, 3, 4, 5, 8, 16 chosen by module duty cycle configuration

Table continues on the next page...

LCD_GCR field descriptions (continued)

Field	Description
2-0 DUTY	<p>LCD duty select</p> <p>DUTY bits select the duty cycle of the LCD controller driver.</p> <p>000 Use 1 BP (1/1 duty cycle). 001 Use 2 BP (1/2 duty cycle). 010 Use 3 BP (1/3 duty cycle). 011 Use 4 BP (1/4 duty cycle). (Default) 100 Use 5 BP (1/5 duty cycle). 101 Use 6 BP (1/6 duty cycle). 110 Use 7 BP (1/7 duty cycle). 111 Use 8 BP (1/8 duty cycle).</p>

52.3.2 LCD auxiliary register (LCD_AR)

The reset value of this register depends on the reset type:POR -- 0x0000_0000

Address: LCD_AR is 400B_E000h base + 4h offset = 400B_E004h

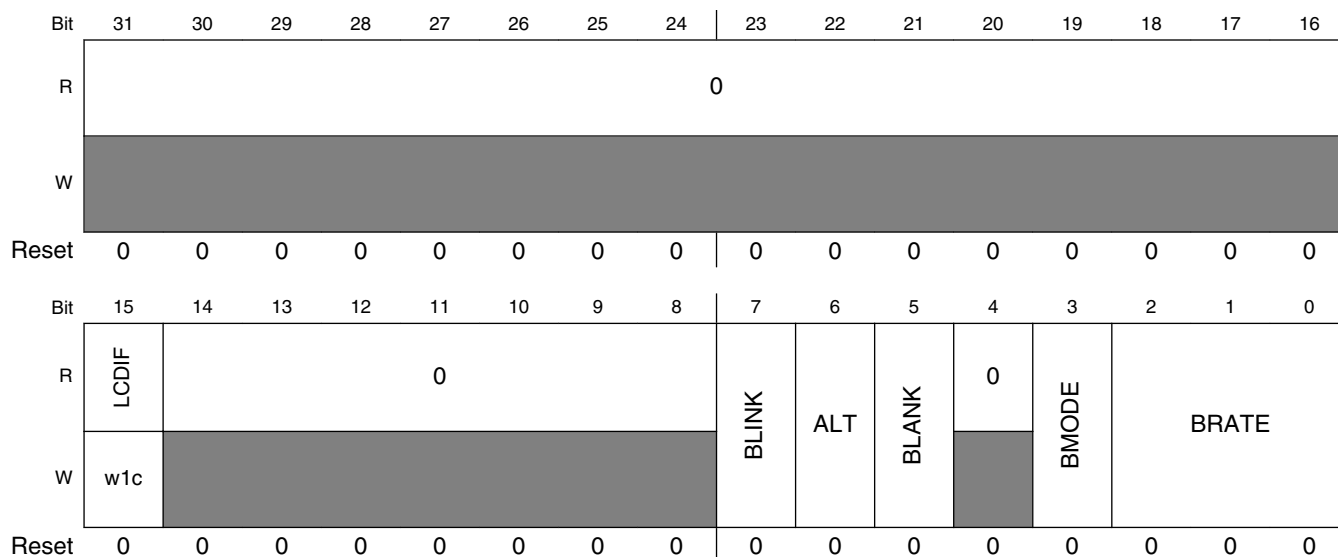

LCD_AR field descriptions

Field	Description
31-16 Reserved	<p>Reserved</p> <p>This read-only field is reserved and always has the value zero.</p>
15 LCDIF	<p>LCD frame frequency interrupt flag</p> <p>LCDIF indicates a frame frequency interrupt condition has occurred. To clear the interrupt, write 1 to LCDIF.</p>

Table continues on the next page...

LCD_AR field descriptions (continued)

Field	Description
	<p>0 Frame frequency interrupt condition has not occurred.</p> <p>1 The start of LCD controller frame has occurred.</p>
14–8 Reserved	<p>Reserved</p> <p>This read-only field is reserved and always has the value zero.</p>
7 BLINK	<p>Blink command</p> <p>Starts or stops LCD controller blinking.</p> <p>0 Disables blinking.</p> <p>1 Starts blinking at blinking frequency specified by LCD blink rate calculation.</p>
6 ALT	<p>Alternate display mode</p> <p>For four backplanes or less, the LCD backplane sequencer changes to output an alternate display. ALT bit is ignored if DUTY[2:0] is 101 or greater.</p> <p>0 Normal display mode.</p> <p>1 Alternate display mode.</p>
5 BLANK	<p>Blank display mode</p> <p>Asserting this bit clears all segments in the LCD display.</p> <p>0 Normal or alternate display mode.</p> <p>1 Blank display mode.</p>
4 Reserved	<p>Reserved</p> <p>This read-only field is reserved and always has the value zero.</p>
3 BMODE	<p>Blink mode</p> <p>Selects the blink mode displayed during the blink period.</p> <p>0 Display blank during the blink period.</p> <p>1 Display alternate display during blink period (Ignored if duty is 5 or greater).</p>
2–0 BRATE	<p>Blink-rate configuration</p> <p>Selects frequency at which the LCD display blinks when the BLINK bit is asserted. The following equation provides an expression for the LCD controller blink rate and shows how BRATE bit field is used in the LCD blink-rate calculation.</p> <p>LCD controller blink rate = LCD clock / $2^{(12 + BRATE)}$</p>

52.3.3 LCD fault detect control register (LCD_FDCR)

The reset value of this register depends on the reset type: POR -- 0x0000_0000

Address: LCD_FDCR is 400B_E000h base + 8h offset = 400B_E008h

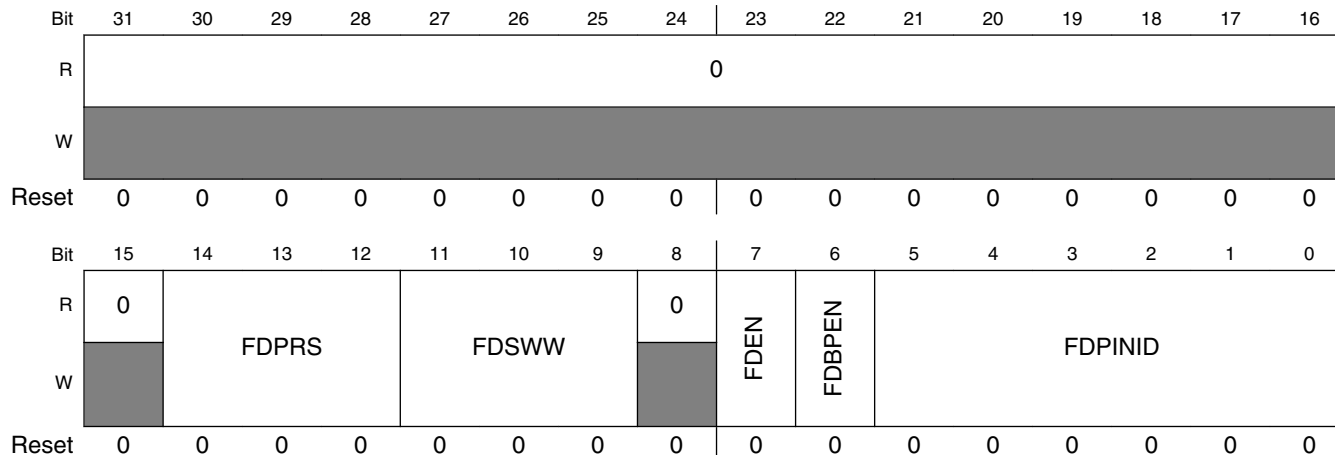

LCD_FDCR field descriptions

Field	Description
31–16 Reserved	Reserved This read-only field is reserved and always has the value zero.
15 Reserved	Reserved This read-only field is reserved and always has the value zero.
14–12 FDPRS	Fault detect clock prescaler Fault detect sample clock frequency is: 0 1/1 bus clock. 1 1/2 bus clock. 2 1/4 bus clock. 3 1/8 bus clock. 4 1/16 bus clock. 5 1/32 bus clock. 6 1/64 bus clock. 7 1/128 bus clock.
11–9 FDSWW	Fault detect sample window width Specifies the sample window width of fault detection, in number of cycles in the range from 4–512 (Sample window = 4*2 ^N). 0 Sample window width is 4 sample clock cycles. 1 Sample window width is 8 sample clock cycles. 2 Sample window width is 16 sample clock cycles. 3 Sample window width is 32 sample clock cycles.

Table continues on the next page...

LCD_FDCR field descriptions (continued)

Field	Description
	4 Sample window width is 64 sample clock cycles. 5 Sample window width is 128 sample clock cycles. 6 Sample window width is 256 sample clock cycles. 7 Sample window width is 512 sample clock cycles.
8 Reserved	Reserved This read-only field is reserved and always has the value zero.
7 FDEN	Fault detect enable If LCDEN is 1, asserting FDEN inserts a test frame after normal LCD refresh frame is completed. After the test frame is done, Fault detection complete flag (FDCF) is set. When the test frame is done, a normal LCD refresh frame starts. FDEN is one-shot register, it clears after FDCF is set. To initiate another fault detection, FDEN must be set again. 0 Disable fault detection. 1 Enable fault detection.
6 FDBPEN	Fault detect backplane enable Enable "backplane" timing for the fault detect circuit. FDBPEN = 0 generates frontplane timing. This bit specifies the type of pin selected under fault detect test. 0 Type of the selected pin under fault detect test is frontplane. 1 Type of the selected pin under fault detect test is backplane.
5-0 FDPINID	Fault detect pin ID Specifies the LCD pin to be checked by pull-up fault detection. 0 Fault detection for LCD_P0 pin. 1 Fault detection for LCD_P1 pin. ... 63 Fault detection for LCD_P63 pin.

52.3.4 LCD fault detect status register (LCD_FDSR)

The reset value of this register depends on the reset type: POR -- 0x0000_0000

Address: LCD_FDSR is 400B_E000h base + Ch offset = 400B_E00Ch

Bit	31	30	29	28	27	26	25	24	23	22	21	20	19	18	17	16
R	0															
W	[Greyed out]															
Reset	0	0	0	0	0	0	0	0	0	0	0	0	0	0	0	0
Bit	15	14	13	12	11	10	9	8	7	6	5	4	3	2	1	0
R	FDCF	0							FDCNT							
W	w1c	[Greyed out]														
Reset	0	0	0	0	0	0	0	0	0	0	0	0	0	0	0	0

LCD_FDSR field descriptions

Field	Description
31–16 Reserved	Reserved This read-only field is reserved and always has the value zero.
15 FDCF	Fault detection complete flag FDCF indicates that the fault detection is completed. Writing 1 to this bit clears this bit to zero. This bit also acts as an interrupt flag when FDCIEN is set. Software can use either interrupt or polling to check if one pin fault detection is completed. 0 Fault detection is not completed. 1 Fault detection is completed.
14–8 Reserved	Reserved This read-only field is reserved and always has the value zero.
7–0 FDCNT	Fault detect counter Contains how many “one/high” are sampled inside the fault detect sample window. 0 No "one" samples. 1 1 "one" samples. 2 2 "one" samples. ... 254 254 "one" samples. 255 255 or more "one" samples. The FDCNT can overflow. Therefore, FDSWW and FDP RS must be reconfigured for proper sampling.

52.3.5 LCD pin enable register (LCD_PENn)

When LCDEN = 1, each PEN bit enables the corresponding LCD pin (LCD_Pn) for LCD operation.

Initialize these registers before enabling the LCD controller.

NOTE

The reset value of this register depends on the reset type:

- POR -- 0x0000_0000

Addresses: LCD_PENL is 400B_E000h base + 10h offset = 400B_E010h

LCD_PENH is 400B_E000h base + 14h offset = 400B_E014h

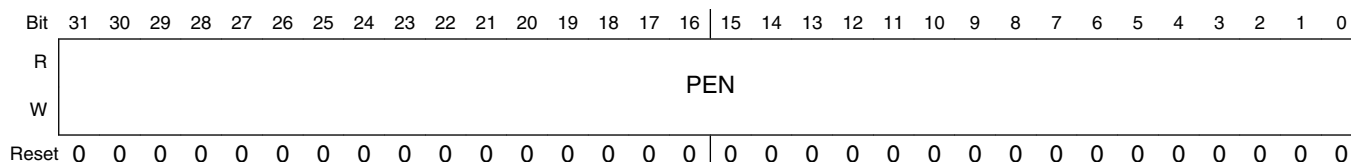

LCD_PEN_n field descriptions

Field	Description
31–0 PEN	<p>LCD pin enable</p> <p>The PEN[63:0] bits enable the LCD_P[63:0] pins for LCD operation. PENL contains PEN[31:0], and PENH contains PEN[63:32].</p> <p>Each LCD_P[63:0] pin can be configured as a backplane or a frontplane based on the corresponding BPEN[<i>n</i>] bit in the backplane enable register (BPEN). If LCDEN = 0, these bits have no effect on the state of the I/O pins. Set PEN[63:0] bits before LCDEN is set.</p> <p>0 LCD operation disabled on LCD_P_n. 1 LCD operation enabled on LCD_P_n.</p>

52.3.6 LCD backplane enable register (LCD_BPEN_n)

When PEN[*n*] = 1, the BPEN[63:0] bits configure the corresponding LCD pin to operate as an LCD backplane or an LCD frontplane. Most applications set a maximum of eight of these bits. Initialize these registers before enabling the LCD controller.

NOTE

The reset value of this register depends on the reset type:

- POR -- 0x0000_0000

Addresses: LCD_BPENL is 400B_E000h base + 18h offset = 400B_E018h

LCD_BPENH is 400B_E000h base + 1Ch offset = 400B_E01Ch

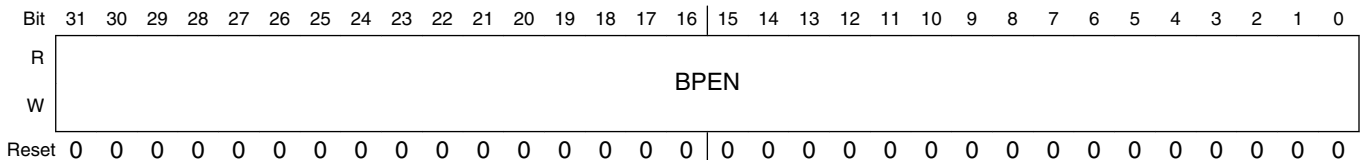

LCD_BPEN_n field descriptions

Field	Description
31–0 BPEN	<p>Backplane enable</p> <p>The BPEN[63:0] bits configure the LCD_P[63:0] pins to operate as an LCD backplane or LCD frontplane. BPENL contains BPEN[31:0], and BPENH contains BPEN[63:32].</p> <p>If LCDEN = 0, these bits have no effect on the state of the I/O pins. It is recommended to set BPEN[63:0] bits before LCDEN is set.</p> <p>0 Frontplane operation enabled on LCD_P_n. 1 Backplane operation enabled on LCD_P_n.</p>

52.3.7 LCD waveform register (LCD_WF3TO0)

The WFn registers each contain four waveform control (WF_n) fields, where x is the n index value of the WF_n field in the least-significant byte (bits 7-0) and y is the n index value of the WF_n field in the most-significant byte (bits 31-24). The bits in each WF_n field control the frontplane segments or backplane phases connected to the LCD_Pn signal.

In an LCD controller, each element consists of a frontplane segment and a backplane phase. These segments and phases are labeled A through H (x8 multiplexing, 1/8 duty cycle). Each LCD_Pn signal can be connected to one or more segments (in frontplane operation) or one or more phases (in backplane operation). An LCD element is turned on when the associated backplane phase is activated and the frontplane segment is on.

If LCD_Pn is configured for frontplane operation, the bits in WF_n turn on or off each of the frontplane segments connected to LCD_Pn: bit 0 controls segment A, bit 1 controls segment B, and so on.

If LCD_Pn is configured for backplane operation, the bits in WF_n activate or deactivate each of the backplane phases connected to LCD_Pn: bit 0 controls phase A, bit 1 controls phase B, and so on.

Software can write to this register with 8-bit, 16-bit, or 32-bit writes. After reset, the WFn register is cleared to 0.

NOTE

The reset value of this register depends on the reset type:

- POR -- 0x0000_0000

Address: LCD_WF3TO0 is 400B_E000h base + 20h offset = 400B_E020h

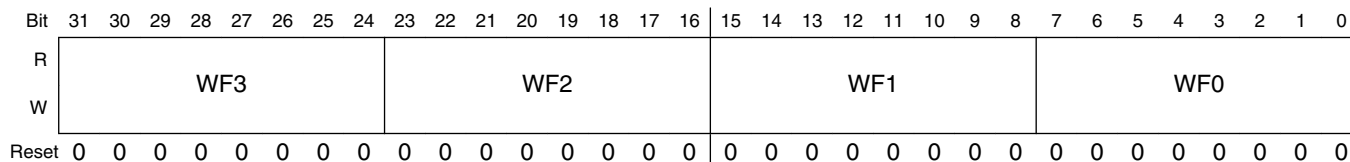

LCD_WF3TO0 field descriptions

Field	Description
31–24 WF3	<p>Segment-on frontplane operation — Each bit turns on or off the segments associated with LCD_P3 in the following pattern: HGFEDCBA (most-significant bit controls segment H and least significant bit controls segment A).</p> <p>Segment-on backplane operation — Each bit activates or deactivates the phases associated with LCD_P3 in the following pattern: HGFEDCBA (most-significant bit controls phase H and least significant bit controls phase A).</p>

Table continues on the next page...

LCD_WF3TO0 field descriptions (continued)

Field	Description
	For each bit: 0 Segment off or phase deactivated 1 Segment on or phase activated
23–16 WF2	Controls segments or phases connected to LCD_P2 as described above for WF3.
15–8 WF1	Controls segments or phases connected to LCD_P1 as described above for WF3.
7–0 WF0	Controls segments or phases connected to LCD_P0 as described above for WF3.

52.3.8 LCD waveform register (LCD_WF7TO4)

See the LCD waveform register (WFC3TO0) for register and field descriptions.

NOTE

The reset value of this register depends on the reset type:

- POR -- 0x0000_0000

Address: LCD_WF7TO4 is 400B_E000h base + 24h offset = 400B_E024h

Bit	31	30	29	28	27	26	25	24	23	22	21	20	19	18	17	16	15	14	13	12	11	10	9	8	7	6	5	4	3	2	1	0
R	WF7								WF6								WF5								WF4							
W																																
Reset	0	0	0	0	0	0	0	0	0	0	0	0	0	0	0	0	0	0	0	0	0	0	0	0	0	0	0	0	0	0	0	0

LCD_WF7TO4 field descriptions

Field	Description
31–24 WF7	Controls segments or phases connected to LCD_P7 as described above for WF3TO0[WF3].
23–16 WF6	Controls segments or phases connected to LCD_P6 as described above for WF3TO0[WF3].
15–8 WF5	Controls segments or phases connected to LCD_P5 as described above for WF3TO0[WF3].
7–0 WF4	Controls segments or phases connected to LCD_P4 as described above for WF3TO0[WF3].

52.3.9 LCD waveform register (LCD_WF11TO8)

See the LCD waveform register (WFC3TO0) for register and field descriptions.

NOTE

The reset value of this register depends on the reset type:

- POR -- 0x0000_0000

Address: LCD_WF11TO8 is 400B_E000h base + 28h offset = 400B_E028h

Bit	31	30	29	28	27	26	25	24	23	22	21	20	19	18	17	16	15	14	13	12	11	10	9	8	7	6	5	4	3	2	1	0
R	WF11								WF10								WF9								WF8							
W																																
Reset	0	0	0	0	0	0	0	0	0	0	0	0	0	0	0	0	0	0	0	0	0	0	0	0	0	0	0	0	0	0	0	0

LCD_WF11TO8 field descriptions

Field	Description
31–24 WF11	Controls segments or phases connected to LCD_P11 as described above for WF3TO0[WF3].
23–16 WF10	Controls segments or phases connected to LCD_P10 as described above for WF3TO0[WF3].
15–8 WF9	Controls segments or phases connected to LCD_P9 as described above for WF3TO0[WF3].
7–0 WF8	Controls segments or phases connected to LCD_P8 as described above for WF3TO0[WF3].

52.3.10 LCD waveform register (LCD_WF15TO12)

See the LCD waveform register (WFC3TO0) for register and field descriptions.

NOTE

The reset value of this register depends on the reset type:

- POR -- 0x0000_0000

Address: LCD_WF15TO12 is 400B_E000h base + 2Ch offset = 400B_E02Ch

Bit	31	30	29	28	27	26	25	24	23	22	21	20	19	18	17	16	15	14	13	12	11	10	9	8	7	6	5	4	3	2	1	0
R	WF15								WF14								WF13								WF12							
W																																
Reset	0	0	0	0	0	0	0	0	0	0	0	0	0	0	0	0	0	0	0	0	0	0	0	0	0	0	0	0	0	0	0	0

LCD_WF15TO12 field descriptions

Field	Description
31–24 WF15	Controls segments or phases connected to LCD_P15 as described above for WF3TO0[WF3].

Table continues on the next page...

LCD_WF15TO12 field descriptions (continued)

Field	Description
23–16 WF14	Controls segments or phases connected to LCD_P14 as described above for WF3TO0[WF3].
15–8 WF13	Controls segments or phases connected to LCD_P13 as described above for WF3TO0[WF3].
7–0 WF12	Controls segments or phases connected to LCD_P12 as described above for WF3TO0[WF3].

52.3.11 LCD waveform register (LCD_WF19TO16)

See the LCD waveform register (WFC3TO0) for register and field descriptions.

NOTE

The reset value of this register depends on the reset type:

- POR -- 0x0000_0000

Address: LCD_WF19TO16 is 400B_E000h base + 30h offset = 400B_E030h

Bit	31	30	29	28	27	26	25	24	23	22	21	20	19	18	17	16	15	14	13	12	11	10	9	8	7	6	5	4	3	2	1	0																
R	WF19								WF18								WF17								WF16																							
W																																																
Reset	0	0	0	0	0	0	0	0	0	0	0	0	0	0	0	0	0	0	0	0	0	0	0	0	0	0	0	0	0	0	0	0	0	0	0	0	0	0	0	0	0	0	0	0	0	0	0	0

LCD_WF19TO16 field descriptions

Field	Description
31–24 WF19	Controls segments or phases connected to LCD_P19 as described above for WF3TO0[WF3].
23–16 WF18	Controls segments or phases connected to LCD_P18 as described above for WF3TO0[WF3].
15–8 WF17	Controls segments or phases connected to LCD_P17 as described above for WF3TO0[WF3].
7–0 WF16	Controls segments or phases connected to LCD_P16 as described above for WF3TO0[WF3].

52.3.12 LCD waveform register (LCD_WF23TO20)

See the LCD waveform register (WFC3TO0) for register and field descriptions.

NOTE

The reset value of this register depends on the reset type:

- POR -- 0x0000_0000

Address: LCD_WF23TO20 is 400B_E000h base + 34h offset = 400B_E034h

Bit	31	30	29	28	27	26	25	24	23	22	21	20	19	18	17	16	15	14	13	12	11	10	9	8	7	6	5	4	3	2	1	0	
R	WF23								WF22								WF21								WF20								
W																																	
Reset	0	0	0	0	0	0	0	0	0	0	0	0	0	0	0	0	0	0	0	0	0	0	0	0	0	0	0	0	0	0	0	0	0

LCD_WF23TO20 field descriptions

Field	Description
31–24 WF23	Controls segments or phases connected to LCD_P23 as described above for WF3TO0[WF3].
23–16 WF22	Controls segments or phases connected to LCD_P22 as described above for WF3TO0[WF3].
15–8 WF21	Controls segments or phases connected to LCD_P21 as described above for WF3TO0[WF3].
7–0 WF20	Controls segments or phases connected to LCD_P20 as described above for WF3TO0[WF3].

52.3.13 LCD waveform register (LCD_WF27TO24)

See the LCD waveform register (WFC3TO0) for register and field descriptions.

NOTE

The reset value of this register depends on the reset type:

- POR -- 0x0000_0000

Address: LCD_WF27TO24 is 400B_E000h base + 38h offset = 400B_E038h

Bit	31	30	29	28	27	26	25	24	23	22	21	20	19	18	17	16	15	14	13	12	11	10	9	8	7	6	5	4	3	2	1	0	
R	WF27								WF26								WF25								WF24								
W																																	
Reset	0	0	0	0	0	0	0	0	0	0	0	0	0	0	0	0	0	0	0	0	0	0	0	0	0	0	0	0	0	0	0	0	0

LCD_WF27TO24 field descriptions

Field	Description
31–24 WF27	Controls segments or phases connected to LCD_P27 as described above for WF3TO0[WF3].
23–16 WF26	Controls segments or phases connected to LCD_P26 as described above for WF3TO0[WF3].
15–8 WF25	Controls segments or phases connected to LCD_P25 as described above for WF3TO0[WF3].

Table continues on the next page...

LCD_WF27TO24 field descriptions (continued)

Field	Description
7–0 WF24	Controls segments or phases connected to LCD_P24 as described above for WF3TO0[WF3].

52.3.14 LCD waveform register (LCD_WF31TO28)

See the LCD waveform register (WFC3TO0) for register and field descriptions.

NOTE

The reset value of this register depends on the reset type:

- POR -- 0x0000_0000

Address: LCD_WF31TO28 is 400B_E000h base + 3Ch offset = 400B_E03Ch

Bit	31	30	29	28	27	26	25	24	23	22	21	20	19	18	17	16	15	14	13	12	11	10	9	8	7	6	5	4	3	2	1	0
R	WF31								WF30								WF29								WF28							
W	WF31								WF30								WF29								WF28							
Reset	0	0	0	0	0	0	0	0	0	0	0	0	0	0	0	0	0	0	0	0	0	0	0	0	0	0	0	0	0	0	0	0

LCD_WF31TO28 field descriptions

Field	Description
31–24 WF31	Controls segments or phases connected to LCD_P31 as described above for WF3TO0[WF3].
23–16 WF30	Controls segments or phases connected to LCD_P30 as described above for WF3TO0[WF3].
15–8 WF29	Controls segments or phases connected to LCD_P29 as described above for WF3TO0[WF3].
7–0 WF28	Controls segments or phases connected to LCD_P28 as described above for WF3TO0[WF3].

52.3.15 LCD waveform register (LCD_WF35TO32)

See the LCD waveform register (WFC3TO0) for register and field descriptions.

NOTE

The reset value of this register depends on the reset type:

- POR -- 0x0000_0000

Address: LCD_WF35TO32 is 400B_E000h base + 40h offset = 400B_E040h

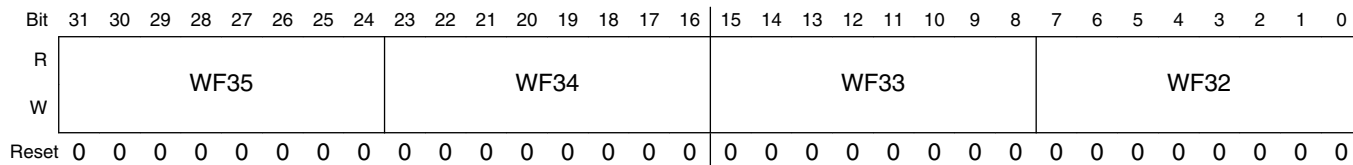

LCD_WF35TO32 field descriptions

Field	Description
31–24 WF35	Controls segments or phases connected to LCD_P35 as described above for WF3TO0[WF3].
23–16 WF34	Controls segments or phases connected to LCD_P34 as described above for WF3TO0[WF3].
15–8 WF33	Controls segments or phases connected to LCD_P33 as described above for WF3TO0[WF3].
7–0 WF32	Controls segments or phases connected to LCD_P32 as described above for WF3TO0[WF3].

52.3.16 LCD waveform register (LCD_WF39TO36)

See the LCD waveform register (WFC3TO0) for register and field descriptions.

NOTE

The reset value of this register depends on the reset type:

- POR -- 0x0000_0000

Address: LCD_WF39TO36 is 400B_E000h base + 44h offset = 400B_E044h

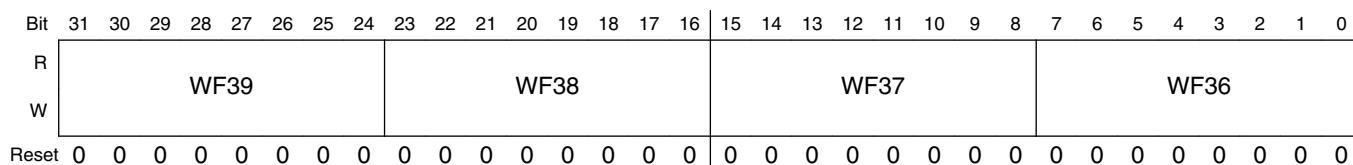

LCD_WF39TO36 field descriptions

Field	Description
31–24 WF39	Controls segments or phases connected to LCD_P39 as described above for WF3TO0[WF3].
23–16 WF38	Controls segments or phases connected to LCD_P38 as described above for WF3TO0[WF3].
15–8 WF37	Controls segments or phases connected to LCD_P37 as described above for WF3TO0[WF3].
7–0 WF36	Controls segments or phases connected to LCD_P36 as described above for WF3TO0[WF3].

52.3.17 LCD waveform register (LCD_WF43TO40)

See the LCD waveform register (WFC3TO0) for register and field descriptions.

NOTE

The reset value of this register depends on the reset type:

- POR -- 0x0000_0000

Address: LCD_WF43TO40 is 400B_E000h base + 48h offset = 400B_E048h

Bit	31	30	29	28	27	26	25	24	23	22	21	20	19	18	17	16	15	14	13	12	11	10	9	8	7	6	5	4	3	2	1	0
R	WF43								WF42								WF41								WF40							
W																																
Reset	0	0	0	0	0	0	0	0	0	0	0	0	0	0	0	0	0	0	0	0	0	0	0	0	0	0	0	0	0	0	0	0

LCD_WF43TO40 field descriptions

Field	Description
31–24 WF43	Controls segments or phases connected to LCD_P43 as described above for WF3TO0[WF3].
23–16 WF42	Controls segments or phases connected to LCD_P42 as described above for WF3TO0[WF3].
15–8 WF41	Controls segments or phases connected to LCD_P41 as described above for WF3TO0[WF3].
7–0 WF40	Controls segments or phases connected to LCD_P40 as described above for WF3TO0[WF3].

52.3.18 LCD waveform register (LCD_WF47TO44)

See the LCD waveform register (WFC3TO0) for register and field descriptions.

NOTE

The reset value of this register depends on the reset type:

- POR -- 0x0000_0000

Address: LCD_WF47TO44 is 400B_E000h base + 4Ch offset = 400B_E04Ch

Bit	31	30	29	28	27	26	25	24	23	22	21	20	19	18	17	16	15	14	13	12	11	10	9	8	7	6	5	4	3	2	1	0
R	WF47								WF46								WF45								WF44							
W																																
Reset	0	0	0	0	0	0	0	0	0	0	0	0	0	0	0	0	0	0	0	0	0	0	0	0	0	0	0	0	0	0	0	0

LCD_WF47TO44 field descriptions

Field	Description
31–24 WF47	Controls segments or phases connected to LCD_P47 as described above for WF3TO0[WF3].
23–16 WF46	Controls segments or phases connected to LCD_P46 as described above for WF3TO0[WF3].
15–8 WF45	Controls segments or phases connected to LCD_P45 as described above for WF3TO0[WF3].
7–0 WF44	Controls segments or phases connected to LCD_P44 as described above for WF3TO0[WF3].

52.3.19 LCD waveform register (LCD_WF51TO48)

See the LCD waveform register (WFC3TO0) for register and field descriptions.

NOTE

The reset value of this register depends on the reset type:

- POR -- 0x0000_0000

Address: LCD_WF51TO48 is 400B_E000h base + 50h offset = 400B_E050h

Bit	31	30	29	28	27	26	25	24	23	22	21	20	19	18	17	16	15	14	13	12	11	10	9	8	7	6	5	4	3	2	1	0																
R	WF51								WF50								WF49								WF48																							
W																																																
Reset	0	0	0	0	0	0	0	0	0	0	0	0	0	0	0	0	0	0	0	0	0	0	0	0	0	0	0	0	0	0	0	0	0	0	0	0	0	0	0	0	0	0	0	0	0	0	0	0

LCD_WF51TO48 field descriptions

Field	Description
31–24 WF51	Controls segments or phases connected to LCD_P51 as described above for WF3TO0[WF3].
23–16 WF50	Controls segments or phases connected to LCD_P50 as described above for WF3TO0[WF3].
15–8 WF49	Controls segments or phases connected to LCD_P49 as described above for WF3TO0[WF3].
7–0 WF48	Controls segments or phases connected to LCD_P48 as described above for WF3TO0[WF3].

52.3.20 LCD waveform register (LCD_WF55TO52)

See the LCD waveform register (WFC3TO0) for register and field descriptions.

NOTE

The reset value of this register depends on the reset type:

- POR -- 0x0000_0000

Address: LCD_WF55TO52 is 400B_E000h base + 54h offset = 400B_E054h

Bit	31	30	29	28	27	26	25	24	23	22	21	20	19	18	17	16	15	14	13	12	11	10	9	8	7	6	5	4	3	2	1	0
R	WF55								WF54								WF53								WF52							
W																																
Reset	0	0	0	0	0	0	0	0	0	0	0	0	0	0	0	0	0	0	0	0	0	0	0	0	0	0	0	0	0	0	0	0

LCD_WF55TO52 field descriptions

Field	Description
31–24 WF55	Controls segments or phases connected to LCD_P55 as described above for WF3TO0[WF3].
23–16 WF54	Controls segments or phases connected to LCD_P54 as described above for WF3TO0[WF3].
15–8 WF53	Controls segments or phases connected to LCD_P53 as described above for WF3TO0[WF3].
7–0 WF52	Controls segments or phases connected to LCD_P52 as described above for WF3TO0[WF3].

52.3.21 LCD waveform register (LCD_WF59TO56)

See the LCD waveform register (WFC3TO0) for register and field descriptions.

NOTE

The reset value of this register depends on the reset type:

- POR -- 0x0000_0000

Address: LCD_WF59TO56 is 400B_E000h base + 58h offset = 400B_E058h

Bit	31	30	29	28	27	26	25	24	23	22	21	20	19	18	17	16	15	14	13	12	11	10	9	8	7	6	5	4	3	2	1	0
R	WF59								WF58								WF57								WF56							
W																																
Reset	0	0	0	0	0	0	0	0	0	0	0	0	0	0	0	0	0	0	0	0	0	0	0	0	0	0	0	0	0	0	0	0

LCD_WF59TO56 field descriptions

Field	Description
31–24 WF59	Controls segments or phases connected to LCD_P59 as described above for WF3TO0[WF3].

Table continues on the next page...

LCD_WF59TO56 field descriptions (continued)

Field	Description
23–16 WF58	Controls segments or phases connected to LCD_P58 as described above for WF3TO0[WF3].
15–8 WF57	Controls segments or phases connected to LCD_P57 as described above for WF3TO0[WF3].
7–0 WF56	Controls segments or phases connected to LCD_P56 as described above for WF3TO0[WF3].

52.3.22 LCD waveform register (LCD_WF63TO60)

See the LCD waveform register (WFC3TO0) for register and field descriptions.

NOTE

The reset value of this register depends on the reset type:

- POR -- 0x0000_0000

Address: LCD_WF63TO60 is 400B_E000h base + 5Ch offset = 400B_E05Ch

Bit	31	30	29	28	27	26	25	24	23	22	21	20	19	18	17	16	15	14	13	12	11	10	9	8	7	6	5	4	3	2	1	0																
R	WF63								WF62								WF61								WF60																							
W																																																
Reset	0	0	0	0	0	0	0	0	0	0	0	0	0	0	0	0	0	0	0	0	0	0	0	0	0	0	0	0	0	0	0	0	0	0	0	0	0	0	0	0	0	0	0	0	0	0	0	0

LCD_WF63TO60 field descriptions

Field	Description
31–24 WF63	Controls segments or phases connected to LCD_P63 as described above for WF3TO0[WF3].
23–16 WF62	Controls segments or phases connected to LCD_P62 as described above for WF3TO0[WF3].
15–8 WF61	Controls segments or phases connected to LCD_P61 as described above for WF3TO0[WF3].
7–0 WF60	Controls segments or phases connected to LCD_P60 as described above for WF3TO0[WF3].

52.4 Functional description

This section provides a complete functional description of the LCD controller.

Before enabling the LCD controller by asserting the LCDEN bit in the GCR, configure the LCD controller based on the end application requirements. Out of reset, the LCD controller is configured with default settings, but these settings are not optimal for every application. The LCD controller provides several versatile configuration settings and options to support varied implementation requirements, including:

- Frame frequency
- Duty cycle (number of backplanes)
- Backplane assignment (which LCD_P[63:0] pins operate as backplanes)
- Frame frequency interrupt enable
- Blinking frequency and options
- Power-supply configurations
- Fault detection configuration

The LCD controller also provides an LCD pin enable control. Setting the LCD pin enable bit in the PENn register for a particular LCD_Pn pin enables the LCD controller functionality of that pin once the LCDEN bit is set. When the backplane enable bit in the BPENn is set, the associated pin operates as a backplane. The WFyTOx registers can then activate (display) the corresponding LCD segments on an LCD panel.

The WFyTOx registers control the on/off state for the segments controlled by the LCD pins defined as front planes and the active phase for the backplanes. Blank display modes do not use the data from the WFyTOx registers. When using the WFyTOx register for frontplane operation, writing a 0 turns the segment off.

For pins enabled as backplane, the bits in WFn fields assign the phases of the backplane (A-H) for the corresponding backplane pin. For a detailed description of LCD controller operation for a basic seven-segment LCD display, see [LCD seven segment example description](#).

52.4.1 LCD controller driver description

The LCD controller driver has 8 modes of operation:

- 1/1 duty (1 backplane) (Phase A), static mode
- 1/2 duty (2 backplanes) (Phase A, B), 1/3 bias (4 voltage levels)
- 1/3 duty (3 backplanes) (Phase A, B, C), 1/3 bias (4 voltage levels)

- 1/4 duty (4 backplanes) (Phase A, B, C, D), 1/3 bias (4 voltage levels)
- 1/5 duty (5 backplanes) (Phase A, B, C, D, E), 1/3 bias (4 voltage levels)
- 1/6 duty (6 backplanes) (Phase A, B, C, D, E, F), 1/3 bias (4 voltage levels)
- 1/7 duty (7 backplanes) (Phase A, B, C, D, E, F, G), 1/3 bias (4 voltage levels)
- 1/8 duty (8 backplanes) (Phase A, B, C, D, E, F, G, H), 1/3 bias (4 voltage levels)

All modes are 1/3 bias. These modes of operation are described in more detail in the following sections.

52.4.1.1 LCD duty cycle

The denominator of the duty cycle indicates the number of LCD panel segments capable of being driven by each individual frontplane output driver. Depending on the duty cycle, the LCD waveform drive can be categorized as static or multiplexed.

In static-driving method, the LCD is driven with two square waveforms. The static-driving method is the most basic method to drive an LCD panel, but because each frontplane driver can drive only one LCD segment, static driving limits the LCD segments that can be driven with a given number of frontplane pins. In static mode, only one backplane is required.

In multiplexed mode, the LCD waveforms are multi-level and depend on the bias mode. Multiplex mode, depending on the number of backplanes, can drive multiple LCD segments with a single frontplane driver. This reduces the number of driver circuits and connections to LCD segments. For multiplex mode operation, at least two backplane drivers are needed. The LCD controller is optimized for multiplex mode.

The numerator of the duty cycle indicates the amount of time the LCD panel segment is energized during each LCD controller frame cycle. The denominator of the duty cycle indicates the number of backplanes that are being used to drive an LCD panel and the number of phase sequences, 1 to 8.

The duty cycle is used by the backplane phase generator to set the phase outputs. The phase outputs A-H are driven according to the sequence shown below. The sequence is repeated at the LCD frame frequency. The duty cycle is configured using the DUTY[2:0] bit field in the GCR, as shown in the following table.

Table 52-30. LCD controller duty cycle modes

Duty	GCR			Number of backplanes	Phase sequence
	DUTY2	DUTY1	DUTY0		
1/1	0	0	0	1	A
1/2	0	0	1	2	A B
1/3	0	1	0	3	A B C
1/4	0	1	1	4	A B C D
1/5	1	0	0	5	A B C D E
1/6	1	0	1	6	A B C D E F
1/7	1	1	0	7	A B C D E F G
1/8	1	1	1	8	A B C D E F G H

52.4.1.2 LCD bias

Because a single frontplane driver is configured to drive more and more individual LCD segments, 3 voltage levels are required to generate the appropriate waveforms to drive the segment. The LCD controller is designed to operate using the 1/3 bias mode.

52.4.1.3 LCD controller base clock and frame frequency

The LCD controller is optimized to operate using a 32.768 kHz clock input. Two clock sources are available to the LCD controller, which are selectable by configuring the SOURCE bit in the GCR. The two clock sources include:

- Default clock (SOURCE = 0)
- Alternate clock (SOURCE = 1)

NOTE

The clock source is chip-specific. For the clock source assignments, see the chapter that describes how modules are configured.

The following figure shows the LCD clock tree. The clock tree shows the two possible clock sources and the LCD frame frequency and blink frequency clock source. The LCD blink frequency is discussed in [Blink frequency](#).

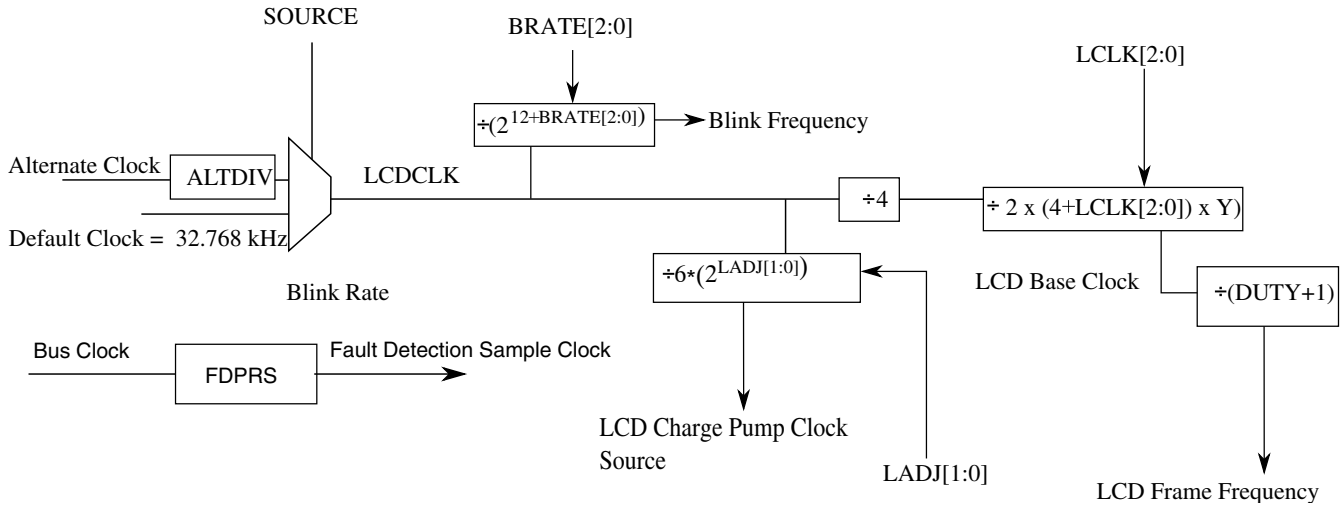

Figure 52-28. LCD clock tree

An external 32.768 kHz clock input is required to achieve lowest power consumption.

The value of LCLK is important because it is used to generate the LCD controller frame frequency.

The following two tables show LCD controller frame frequency calculations that consider several possible LCD controller configurations of LCLK[2:0] and DUTY[2:0].

The LCD controller frame frequency is defined as the number of times the LCD segments are energized per second. The LCD controller frame frequency must be selected to prevent the LCD display from flickering (LCD controller frame frequency is too low) or ghosting (LCD controller frame frequency is too high). To avoid these issues, an LCD controller frame frequency in the range of 28 to 58 Hz is required. LCD controller frame frequencies less than 28 Hz or greater than 58 Hz are out of specification, and so are invalid. Selecting lower values for the LCD base and frame frequency results in lower current consumption for the LCD controller.

The LCD controller base clock frequency is the LCD controller frame frequency multiplied by the number of backplane phases that are being generated. The number of backplane phases is selected using the DUTY[2:0] bits. The LCD controller base clock is used by the backplane sequencer to generate the LCD waveform data for the enabled phases (A-H).

Table 52-31. LCD controller frame frequency calculations for clock input ~ 32.768 kHz

Duty cycle	1/1	1/2	1/3	1/4	1/5	1/6	1/7	1/8
Y	16	8	5	4	3	3	2	2
LCLK[2:0]								
0	64	64	68.3	64	68.3	56.9	73.1	64

Table continues on the next page...

Table 52-31. LCD controller frame frequency calculations for clock input ~ 32.768 kHz (continued)

Duty cycle	1/1	1/2	1/3	1/4	1/5	1/6	1/7	1/8
Y	16	8	5	4	3	3	2	2
LCLK[2:0]								
1	51.2	51.2	54.6	51.2	54.6	45.5	58.5	51.2
2	42.7	42.7	45.5	42.7	45.5	37.9	48.8	42.7
3	36.6	36.6	39	36.6	39	32.5	41.8	36.6
4	32	32	34.1	32	34.1	28.4	36.6	32
5	28.4	28.4	30.3	28.4	30.3	25.3	32.5	28.4
6	25.6	25.6	27.3	25.6	27.3	22.8	29.3	25.6
7	23.3	23.3	24.8	23.3	24.8	20.7	26.6	23.3

Table 52-32. LCD controller frame frequency calculations for clock input ~ 39.063 kHz

Duty cycle	1/1	1/2	1/3	1/4	1/5	1/6	1/7	1/8
Y	16	8	5	4	3	3	2	2
LCLK[2:0]								
0	76.3	76.3	81.4	76.3	81.4	67.8	87.2	76.3
1	61	61	65.1	61	65.1	54.3	69.8	61
2	50.9	50.9	54.3	50.9	54.3	45.2	58.1	50.9
3	43.6	43.6	46.5	43.6	46.5	38.8	49.8	43.6
4	38.1	38.1	40.7	38.1	40.7	33.9	43.6	38.1
5	33.9	33.9	36.2	33.9	36.2	30.1	38.8	33.9
6	30.5	30.5	32.6	30.5	32.6	27.1	34.9	30.5
7	27.7	27.7	29.6	27.7	29.6	24.7	31.7	27.7

NOTE

The shaded entries in above tables are out of specification and invalid.

52.4.1.4 LCD waveform examples

This section shows the timing examples of the LCD output waveforms for the several modes of operation. As shown in the following table, all examples use 1/3 bias mode.

Table 52-33. Configurations for example LCD waveforms

	Bias mode	DUTY[2:0]	Duty cycle
Example 1	1/3	001	1/2
Example 2		011	1/4
Example 3		111	1/8

52.4.1.4.1 1/2 Duty multiplexed with 1/3 bias mode (low-power waveform)

Duty=1/2:DUTY[2:0] = 001

LCD_P[1:0] enabled as backplanes:

BPEN0 =1 and BPEN1 =1 in the BPEN0

LCD_P0 assigned to Phase A: WF0 = 0x01

LCD_P1 assigned to Phase B: WF1 = 0x02, WF1TO0 = 0x00000201

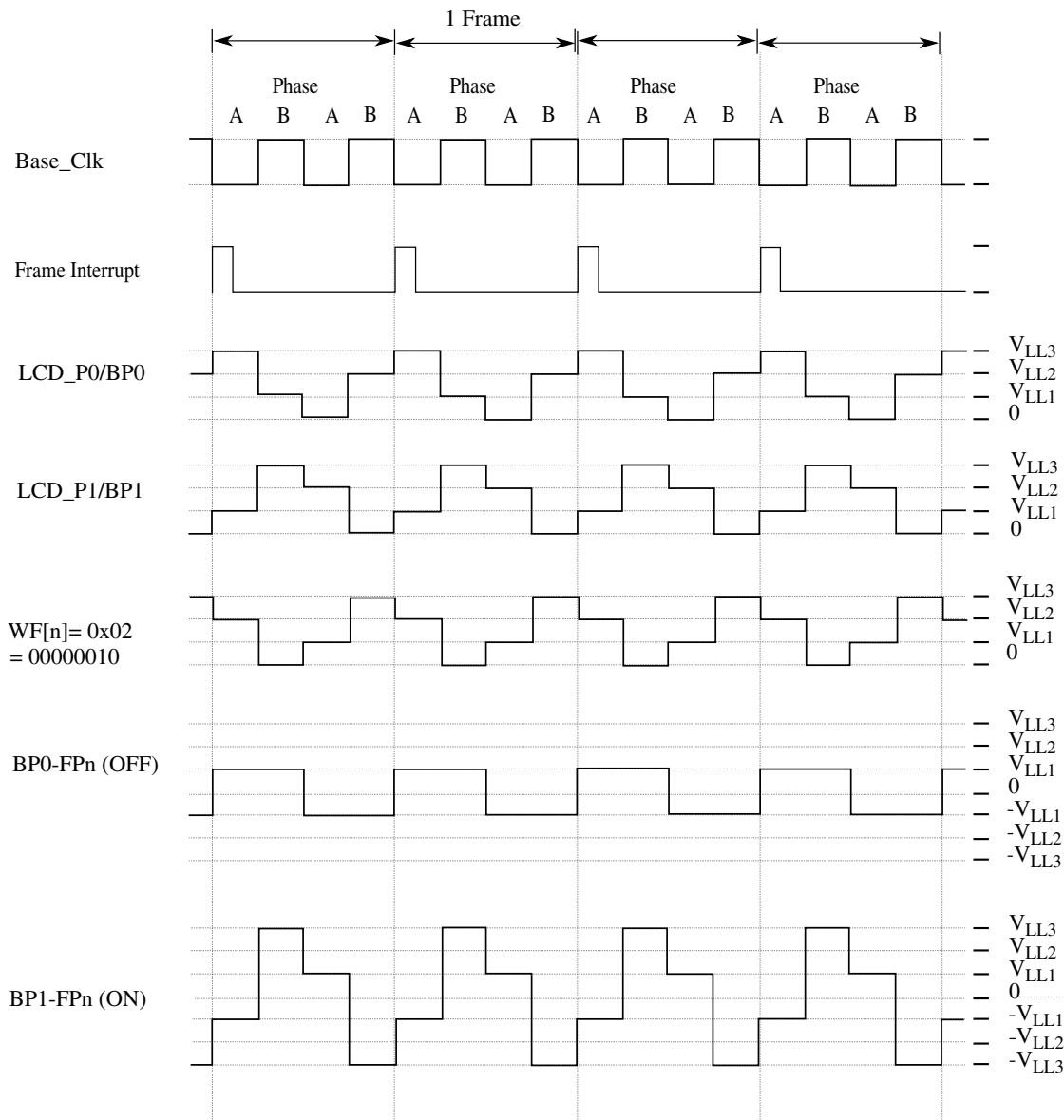

Figure 52-29. 1/2 Duty and 1/3 bias (low-power waveform)

52.4.1.4.2 1/4 Duty multiplexed with 1/3 bias mode (low-power waveform)

Duty = 1/4: DUTY[2:0] = 011

LCD_P[3:0] enabled as backplanes: BPEN0 = 0x0F

LCD_P0 assigned to Phase A: WF0 = 0x01

LCD_P1 assigned to Phase B: WF1 = 0x02

LCD_P2 assigned to Phase C: WF2 = 0x04

LCD_P3 assigned to Phase D: WF3 = 0x08, , WF3TO0 = 0x08040201

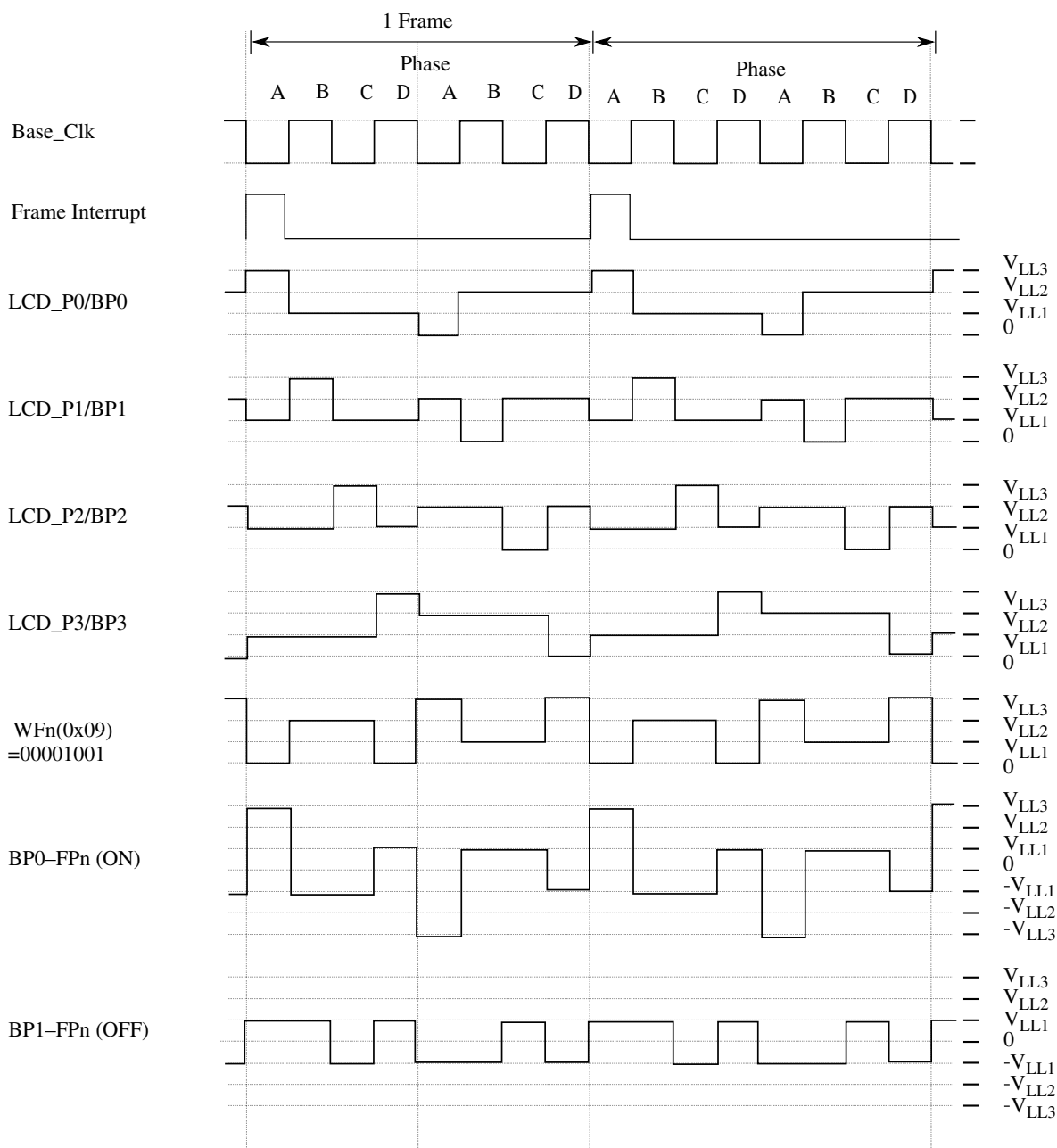

Figure 52-30. 1/4 Duty and 1/3 bias (low-power waveform)

52.4.1.4.3 1/8 Duty multiplexed with 1/3 bias mode (low-power waveform)

Duty = 1/8:DUTY[2:0] = 111

LCD_P[7:0] enabled as backplanes: BPEN0 = 0xFF

LCD_P0 assigned to Phase A: WF0 = 0x01

LCD_P1 assigned to Phase B: WF1 = 0x02

LCD_P2 assigned to Phase C: WF2 = 0x04

functional description

LCD_P3 assigned to Phase D: WF3 = 0x08

LCD_P4 assigned to Phase E: WF4 = 0x10

LCD_P5 assigned to Phase F: WF5 = 0x20

LCD_P6 assigned to Phase G: WF6 = 0x40

LCD_P7 assigned to Phase H: WF7 = 0x80, WF7TO4 = 0x80402010, WF3TO0 = 0x08040201

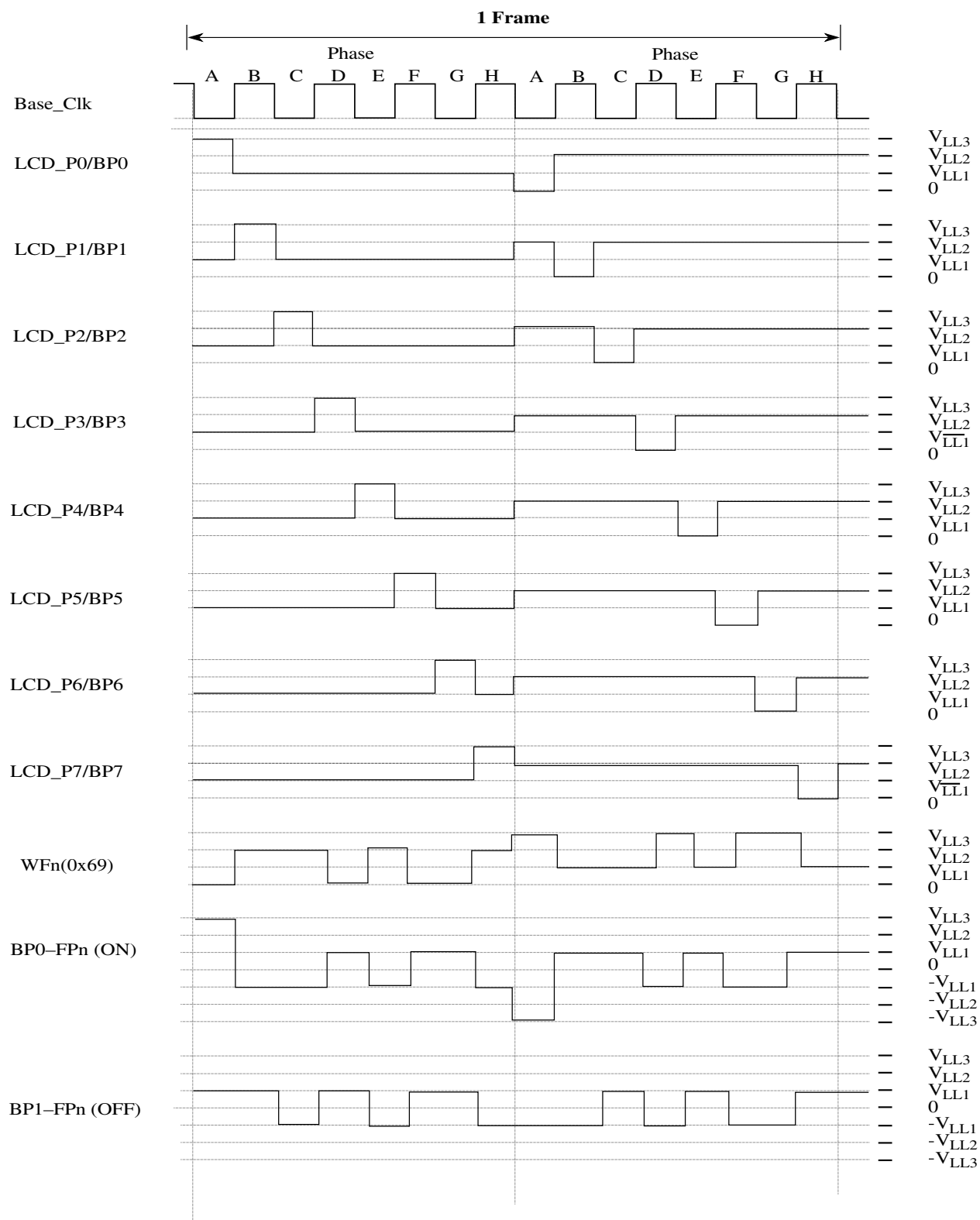

Figure 52-31. 1/8 Duty and 1/3 bias (low-power waveform)

52.4.2 WfYTOx registers

For a segment on the LCD panel to be displayed, data must be written to the WfYTOx registers. For LCD pins enabled as frontplanes, each bit in the WfYTOx registers corresponds to a segment on an LCD panel. The different phases (A-H) represent the different backplanes of the LCD panel. The selected LCD duty cycle controls the number of implemented phases. Refer to the [Table 52-30](#) for normal LCD operation the phases follow the sequence shown.

For LCD pins enabled as a backplane, the WfYTOx register assigns the phase in which the backplane pin is active. This is how backplane assignment is done.

An example of normal operation follows.

To enable LCD_P0 to operate as backplane 0.

1. Enable the LCD_P0 by setting PEN0 bit in the PENL register, PENL = 0x00000001.
2. Configure LCD_P0 as a backplane pin by setting the BPEN0 bit in the BPEN0 register.
3. The WF0 bit in the WF3TO0 register is set to associate LCD_P0 with backplane phase A, WF3to0 = 0x00000001.

This configures LCD_P0 to operate as a backplane that is active in phase A.

For LCD pins enabled as a frontplane:

- Writing 1 to a given WF location results in the corresponding display segment being driven with the differential root mean square (RMS) voltage necessary to turn the segment on during the phase selected.
- Writing 0 to a given location results in the corresponding display segment being driven with the differential RMS voltage necessary to turn the segment off during the phase selected.

52.4.3 LCD display modes

The LCD controller can be configured to implement several different display modes. In the LCD auxiliary register (AR), the bits ALT and BLANK configure the different display modes:

Normal display mode (default)

The LCD segments are controlled by the data placed in the WfYTOx registers, as described in the preceding section.

Blank display mode

The WF data is bypassed and the frontplane and backplane pins are configured to clear all segments.

Alternate display mode

The backplane sequence is modified for duty cycles of 1/4, 1/3, 1/2, and 1/1.

For four backplanes or less, the backplane sequence is modified as shown below. The altered sequence allows two complete displays to be placed in the WFyTOx registers. The first display is placed in phases A-D and the second in phases E-H in the case of four backplanes. If the LCD duty cycle is five backplanes or greater, the ALT bit is ignored and creates a blank display. Refer to [Table 52-35](#) for additional information.

NOTE

For alternate display modes, both the segment data and the backplane configuration must be configured for both the upper and lower nibble. For Example, if LCD_P0 is configured as backplane 0 (phase A) then for proper operation in Alternate Display mode, the WF3TO0 should be set to 0x00000011 to set both BPEWF0 and BPAWF0.

Using the alternate display function an inverse display can be accomplished for x4 mode and less by placing inverse data in the alternate phases of the WFyTOx registers.

Table 52-34. Alternate display backplane sequence

Duty	Backplane sequence	Alt. backplane sequence
1/1	A	E
1/2	A B	E F
1/3	A B C	E F G
1/4	A B C D	E F G H

52.4.3.1 LCD blink modes

The blink mode is used as a means of alternating among different LCD display modes at a defined frequency. The LCD controller can be configured to implement two blink modes. The BMODE bit in the LCD auxiliary register (AR) configures the different blink modes. Blink modes are activated by setting the BLINK bit in the AR. If BLINK = 0, the LCD controller operates normally as described in [LCD display modes](#). If BLINK = 1, BMODE bit configures the blinking operation. During a blink, the display data driven by the LCD controller changes to the mode selected by the BMODE bit. The BMODE bit selects two different blink modes, blank and alternate modes operate in the same way, as defined in [LCD display modes](#). The table below shows the interaction between display modes and blink modes. If the LCD duty cycle is five backplanes or greater, BMODE = 1 is ignored and reverts to create a blank display during the blink period.

Table 52-35. Display mode interaction

BLANK	ALT	BMODE	LCD duty cycle	BLINK = 1	
				Normal period	Blink period
0	0	0	1-4	Normal display	Blank display
0	0	1	1-4	Normal display	Alternate display ¹
0	1	0	1-4	Alternate display ¹	Blank display
0	1	1	1-4	Alternate display ¹	Alternate display ¹
1	x	0	1-4	Blank display	Blank display
1	x	1	1-4	Blank display	Alternate display ¹
0	x	x	5-8	Normal display	Blank display
1	x	x	5-8	Blank display	Blank display

1. For alternate display modes, both the segment data and the backplane configuration must be configured for both the upper and lower nibble. For Example, if LCD_P0 is configured as backplane 0 (phase A) then for proper operation in Alternate Display mode, the WF3to0 should be set to 0x00000011 to set both BPEWF0 and BPAWF0.

52.4.3.2 Blink frequency

The LCD clock is the basis for the calculation of the LCD controller blink frequency. The LCD controller blink frequency is equal to the LCD clock (LCLK) divided by the factor selected by the BRATE[2:0] bits. The following table shows LCD controller blink frequency calculations for all values of BRATE[2:0] at a few common LCLK selections.

Table 52-36. Blink frequency calculations (Blink rate = LCD clock (Hz) ÷ Blink divider)

BRATE[2:0]	0	1	2	3	4	5	6	7
LCD clock	Blink frequency (Hz)							
30 kHz	7.32	3.66	1.831	0.916	0.46	0.23	0.11	0.06
32.768 kHz	8	4	2	1	0.5	0.25	0.13	0.06
39.063 kHz	9.54	4.77	2.38	1.19	0.6	0.30	0.15	0.075

52.4.4 LCD charge pump and power supply operation

This section describes the LCD charge pump and LCD power supply configuration options.

The LCD bias voltages (V_{LL1} , V_{LL2} and V_{LL3}) can be generated by the LCD charge pump or a resistor divider network that is connected using the CPSEL bit. The input source to the LCD charge pump is controlled by the VSUPPLY[1:0] bit field.

VSUPPLY[1:0] indicates the state of internal signals used to configure power switches as shown in the table in the following figure. The block diagram in the following figure illustrates several potential operational modes for the LCD controller including configuration of the LCD controller power supply source using V_{DD} , internal regulated voltage V_{IREG} or an external supply on the V_{LL3} . V_{LL3} should never be externally driven to any level other than V_{DD} .

Upon Reset the VSUPPLY[1:0] bits are configured to connect V_{LL3} to V_{DD} . This configuration should be changed to match the application requirements before the LCD controller is enabled.

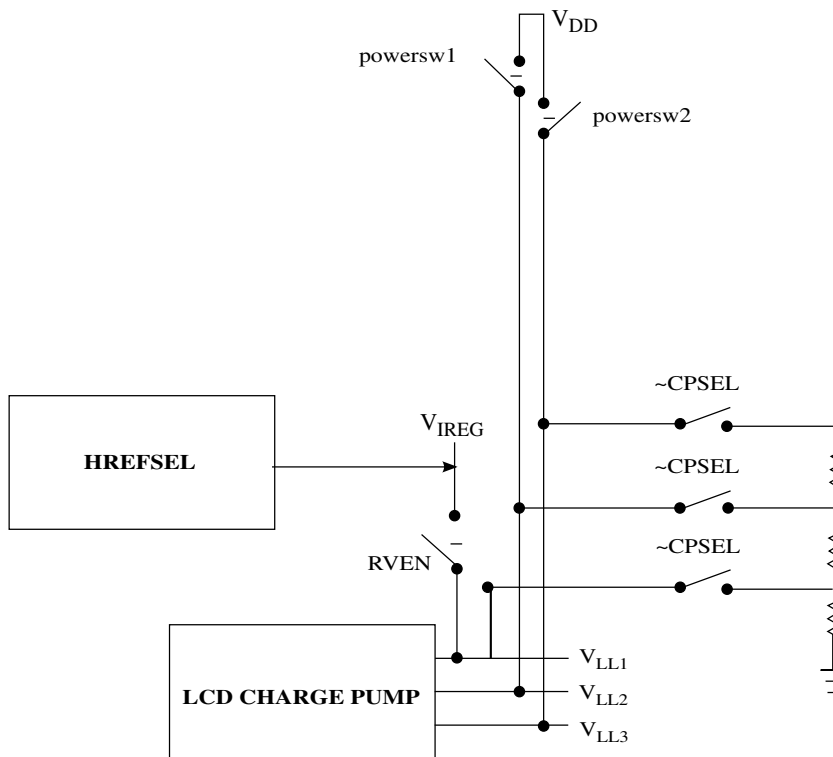

Figure 52-32. LCD charge pump block diagram

Table 52-37. LCD power supply configuration options

VSUPPLY[1:0]	Configuration	powersw1	powersw2
00	Drive V_{LL2} internally from V_{DD}	1	0
01	Drive V_{LL3} internally from V_{DD}	0	1
10	Reserved	0	0

Table continues on the next page...

Table 52-37. LCD power supply configuration options (continued)

VSUPPLY[1:0]	Configuration	powersw1	powersw2
11	Drive V_{LL3} externally from V_{DD} or Drive V_{LL1} internally from V_{IREG}	0	0

Note

The charge pump is optimized for 1/3 bias mode operation only.

The charge pump requires external capacitance for its operation. To provide this external capacitance, the V_{cap1} and V_{cap2} external pins are provided. It is recommended that a ceramic capacitor be used. Proper orientation is imperative when using a polarized capacitor. The recommended value for the external capacitor is 0.1 μ F.

52.4.4.1 LCD power supply configuration

The LCD bias voltages can be internally derived from V_{DD} , internally derived from a voltage source (should never be externally driven to any level other than V_{DD}) connected to V_{LL3} , internally derived from a regulated voltage source that can be configured to supply 1.0 or 1.67 V (V_{IREG}). The following table provides a more detailed description of the power state of the LCD controller that depends on the configuration of the VSUPPLY[1:0], CPSEL and RVEN bits. The table shows all possible configurations of the LCD power supply. All other combinations of the configuration bits above are not permissible LCD power supply modes and should be avoided.

Table 52-38. LCD power supply options

LCD operational state	LCD power supply configuration	VSUPPLY[1:0]	HREFSEL	CPSEL	RVEN
V_{LL2} connected to V_{DD} internally for 3 V or 5 V glass operation.	For 3 V glass operation, V_{DD} must be equal to 2 V. For 5 V glass operation, V_{DD} must be equal to 3.33 V. Charge pump is used to generate V_{LL1} and V_{LL3} .	00	X	1	0

Table continues on the next page...

Table 52-38. LCD power supply options (continued)

LCD operational state	LCD power supply configuration	VSUPPLY[1:0]	HREFSEL	CPSEL	RVEN
V_{LL3} connected to V_{DD} internally for 3 V or 5 V glass operation.	For 3 V glass operation, V_{DD} must be equal to 3 V. For 5 V glass operation, V_{DD} must be equal to 5 V. Charge pump is used to generate V_{LL1} and V_{LL2} .	01	X	1	0
V_{LL3} is driven externally for 3 V LCD glass operation.	For 3 V glass operation, V_{LL3} must be equal to 3 V. Charge pump is used to generate V_{LL1} and V_{LL2} .	11	X	1	0
V_{LL3} is driven externally for 5 V LCD glass operation. V_{LL3} must be equal to V_{DD} . This operation is not allowed for 1.8 V to 3.6 V parts.	For 5 V glass operation, V_{LL3} must be equal to 5 V. Charge pump is used to generate V_{LL1} and V_{LL2} .	11	X	1	0
V_{LL3} is driven externally for 3 V LCD glass operation. Resistor Bias Network enabled.	For 3 V glass operation V_{LL3} must be equal to 3 V. Charge pump is disabled. Resistor Bias network is used to create V_{LL1} and V_{LL2} .	11	X	0	0
V_{LL3} is driven externally for 5 V LCD glass operation. Resistor Bias network enabled. V_{LL3} must be equal to V_{DD} . This operation is not allowed for 1.8 V to 3.6 V parts.	For 5 V glass operation V_{LL3} must be equal to 5 V. Charge pump is disabled. Resistor Bias network is used to create V_{LL1} and V_{LL2} .	11	X	0	0
$V_{I\text{REG}}$ is connected to V_{LL1} for 5 V glass operation. The HREFSEL bit is used to select 1.0 V or 1.67 V range for $V_{I\text{REG}}$.	For 5 V glass operation, HREFSEL = 1, $V_{I\text{REG}} = 1.67$ V. $V_{I\text{REG}}$ is connected to V_{LL1} internally. Charge pump is used to generate V_{LL2} and V_{LL3} .	11	1	1	1

Table continues on the next page...

Table 52-38. LCD power supply options (continued)

LCD operational state	LCD power supply configuration	VSUPPLY[1:0]	HREFSEL	CPSEL	RVEN
<p>V_{IREG} is connected to V_{LL1} for 3 V glass operation.</p> <p>The HREFSEL bit is used to select 1.0 V or 1.67 V range for V_{IREG}</p>	<p>For 3 V glass operation, HREFSEL= 0, $V_{IREG} = 1$ V.</p> <p>V_{IREG} is connected to V_{LL1} internally.</p> <p>Charge pump is used to generate V_{LL2} and V_{LL3}.</p>	11	0	1	1

52.4.4.1.1 LCD external power supply, VSUPPLY[1:0] = 11

When VSUPPLY[1:0] = 11, powersw1, powersw2, are deasserted. V_{DD} is not available to power the LCD controller internally, so the LCD controller requires an external power source for V_{LL1} , V_{LL2} , and V_{LL3} when the charge pump is disabled.

If the charge pump is enabled, external power must be applied to V_{LL3} . With this configuration, the charge pump generates the other LCD bias voltages V_{LL1} and V_{LL2} .

Internal V_{IREG}

If the charge pump is enabled, the internal regulated voltage, V_{IREG} , can be used as an input to generate the LCD bias voltages. In this state, external voltage source should not be connected to V_{LL1} , V_{LL2} , or V_{LL3} . V_{IREG} is controlled by the LCD general control register (GCR). Figure 52-32 shows that V_{IREG} is connected to V_{LL1} when the RVEN bit is set.

V_{LL1} is connected to the internal charge pump. Using the charge pump, the value of V_{LL1} is tripled and output as V_{LL3} . For 3 V LCD glass, V_{LL3} should be approximately 3 V; while for 5 V LCD glass, V_{LL3} should be approximately 5 V.

The HREFSEL bit in the GCR is used to set V_{IREG} to approximately 1.0 V or 1.67 V as shown in the following table. The GCR contains trim bits that can be used to make changes to the regulated voltage. The trim can be used to increase or decrease the regulated voltage by 1.5% for each count. A total of $\pm 12\%$ of change can be done to the regulated voltage.

The following table shows the selected LCD bias voltages V_{LL1} , V_{LL2} , and V_{LL3} values based on the value of V_{IREG} .

Table 52-39. Bias voltage typical values

HREFSEL	V _{IREF}	V _{LL1} = V _{ref}	V _{LL2} = 2 × V _{ref}	V _{LL3} = 3 × V _{ref}
HREFSEL = 0	1.0 V	1.0 V	2.0 V	3.0 V
HREFSEL = 1	1.67 V	1.67 V	3.33 V	5.0 V

52.4.4.1.2 LCD internal power supply, VSUPPLY[1:0] = 00 or 01

V_{DD} is used as the LCD controller power supply when VSUPPLY[1:0] = 00 or 11 (as shown in the following table). When powering the LCD controller using V_{DD}, the charge pump must be enabled (CPSEL = 1). The following table provides recommendations regarding configuration of the VSUPPLY[1:0] bit field when using both 3 V and 5 V LCD panels.

Table 52-40. V_{DD} switch option

VSUPPLY[1:0]	V _{DD} switch option	Recommend use for 3 V LCD panels	Recommend use for 5 V LCD panels
00	V _{LL2} is generated from V _{DD}	Invalid LCD configuration	<ul style="list-style-type: none"> • V_{LL1} = 1.67 V • V_{DD} = V_{LL2} = 3.3 V • V_{LL3} = 5 V
01	V _{LL3} is generated from V _{DD}	<ul style="list-style-type: none"> • V_{LL1} = 1 V • V_{LL2} = 2 V • V_{DD} = V_{LL3} = 3 V 	Invalid LCD configuration

52.4.5 Resets

During a reset, the LCD controller is configured in the default mode. The default mode includes the following settings:

- LCDEN is cleared, thereby forcing all frontplane and backplane driver outputs to the high impedance state.
- 1/4 duty
- 1/3 bias
- LCLK[2:0], VSUPPLY[1:0], CPSEL, RVEN, and BRATE[2:0] revert to their reset values, V_{LL3} is internally connected to V_{DD}

52.4.6 Interrupts

When an LCD controller frame-frequency interrupt event occurs, the LCDIF bit in the AR is asserted. The LCDIF bit remains asserted until software clears the LCD controller frame frequency interrupt. The interrupt can be cleared by software writing a 1 to the LCDIF bit. The LCD controller frame frequency interrupt is not available in all low power modes.

If both the LCDIF bit in the AR and the LCDIEN bit in the GCR are set, an LCD interrupt signal asserts.

When a fault detection complete event occurs, FDCF bit is set. the FDCF bit remains asserted until software writes 1 to clear. if both FDCF and FDCIEN bits are set, an LCD interrupt signal is asserted.

52.4.7 LCD display fault detect circuit

Most failures, where a LCD segment is either unexpectedly on or off, result in an erroneous information that can mislead a user and cause a dangerous situation. The LCD Display Fault Detect circuit's (LFD) function finds faults in the LCD display, display connector, and board connections between the MCU and the display.

The LCD panel could be regarded as a matrix of segments, as shown in the following figures. Any open/short connection changes the capacitive characteristics of the segment matrix . The pullup fault detection checks the capacitive characteristic of an LCD_Pn pin by applying a weak pullup voltage to the display capacitor matrix. The rise time response is sampled and summed within a user defined time frame and stored for postprocessing in the FDSR[FDCNT] bitfield. The summing of the digitized values uses the principle that the response of a capacitor for each charge/discharge is constant for the same loading conditions.

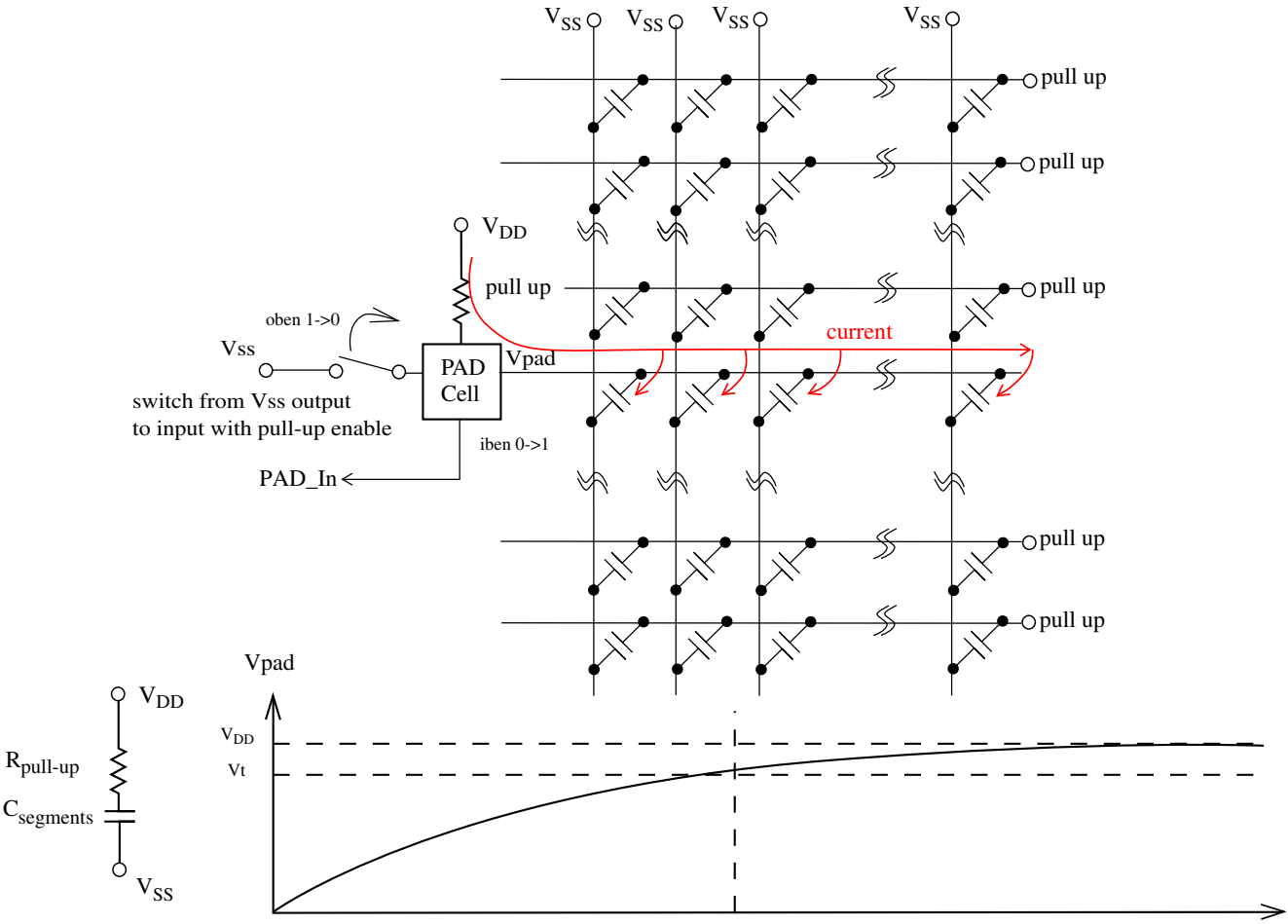
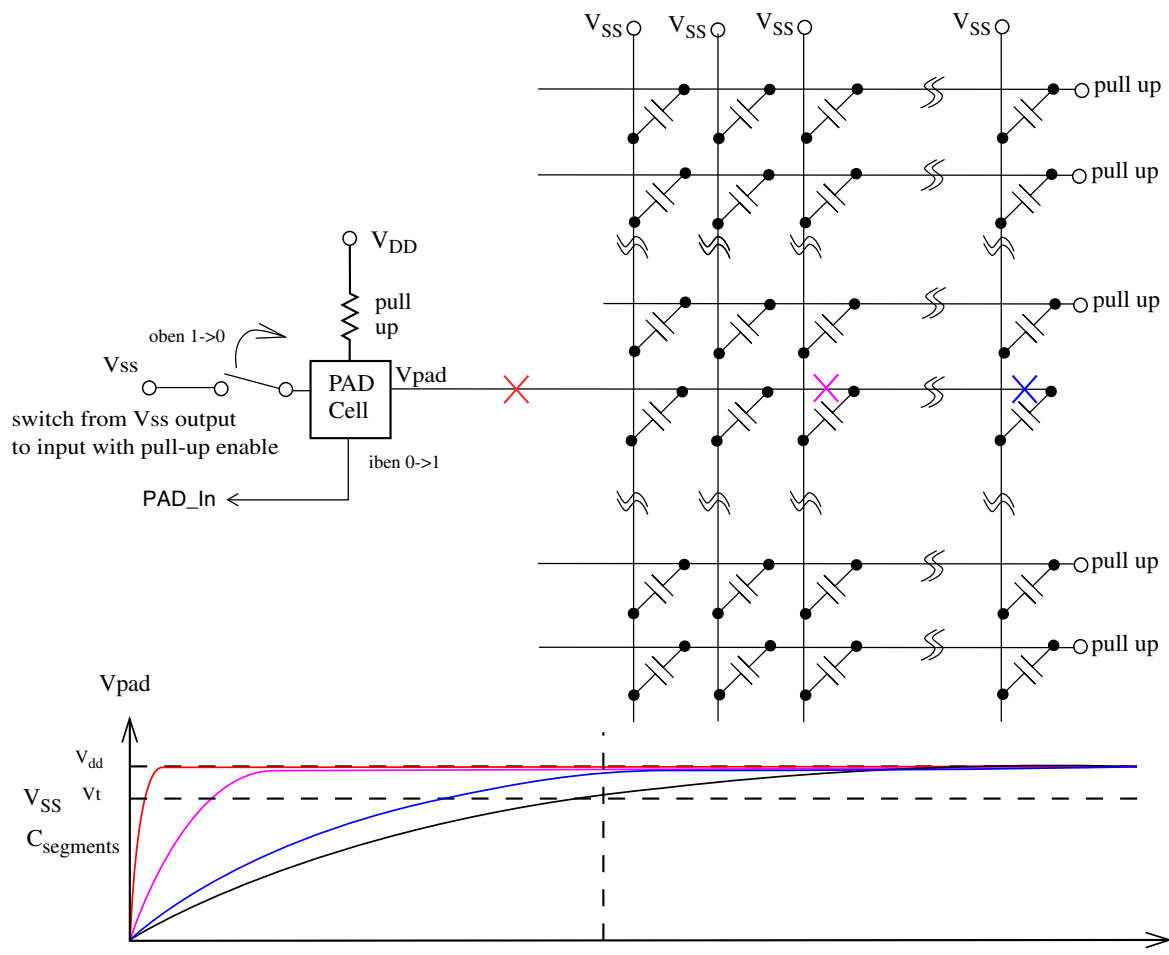
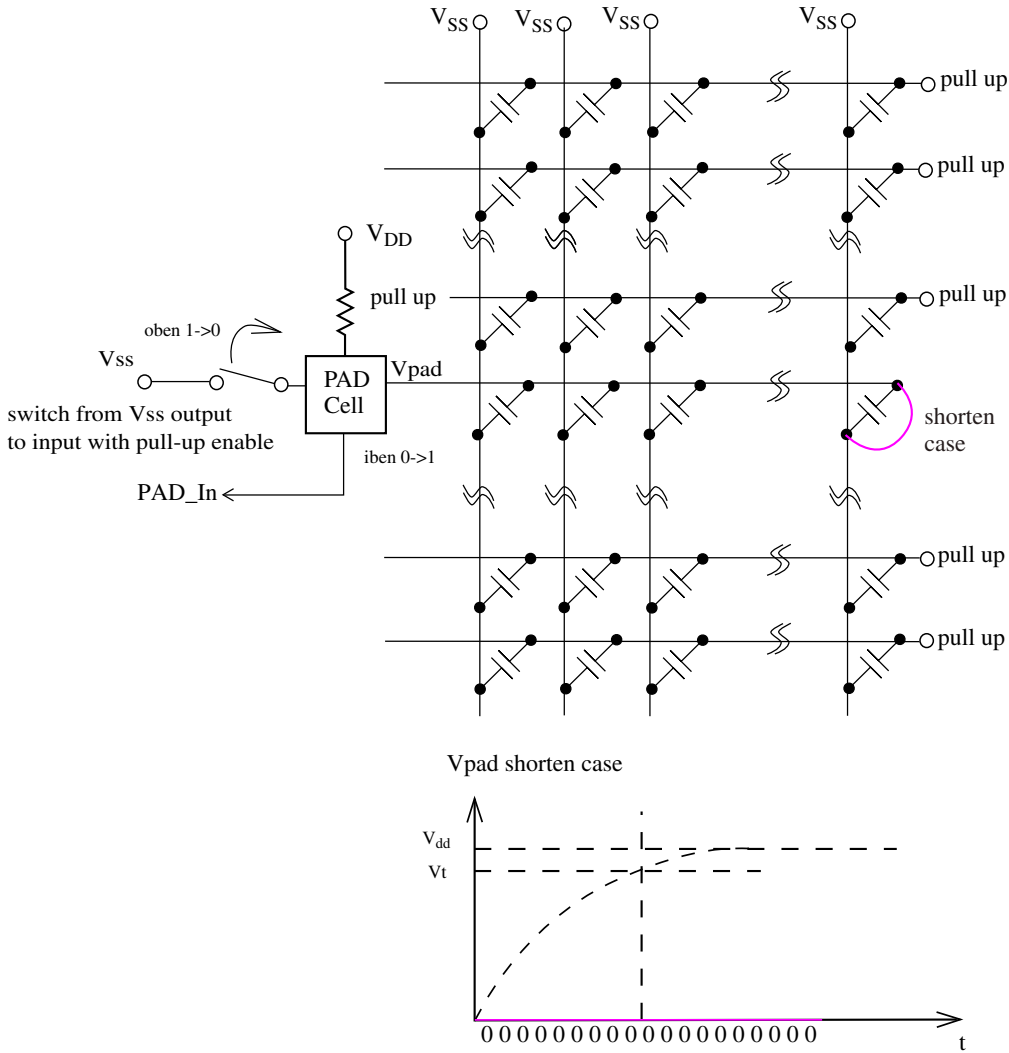

Figure 52-33. Pullup fault detect in connection/segment normal case



If there's any open case in connection or panel, the $C_{segments}$ will become smaller, which makes the pull-up time less

Figure 52-34. Pullup fault detect in connection/segment open case



If there's any short case between BP and FP, V_{pad} will be shorten to V_{SS} and never be pulled up.

Figure 52-35. Pullup fault detect in connection/segment short case

This circuit works by measuring the capacitance of the LCD frontplane (FP) or backplane (BP) connection and comparing it to a reference number. This reference number is usually measured at the user's production facility (by this circuit) and stored for later comparison in the flash. The comparison must account for fluctuations due to temperature, voltage, and other environmental effects. Intelligent software may be able to account for these effects more accurately by using time-dependent algorithms; but the basic comparison to a factory-measured number should be sufficient for most applications.

This circuit can measure the following:

- FP or BP rise time response changes, including pad, pin, board, and all pixels connected to the measured FP or BP.

functional description

- Short circuits in the FP or BP connection (all silicon or board locations), see [Figure 52-35](#).
- Excessive leakage in the FP or BP connection (silicon or board).
- Supply connectivity through the driver for the VSS level.
- Opens in the FP or BP connection (bondwire, package, silicon, or board), see [Figure 52-35](#).

The purpose of this circuit is not to:

- Measure independent pixel capacitances.
- Measure voltage levels or contrast.
- Measure the open connections between the FP/BP and the V_{LL1} , V_{LL2} , and V_{LL3} drivers.
- If there is any open case in connection or panel, the $C_{segments}$ becomes smaller, which changes the rise time response.

Pullup fault detection can be performed while LCDEN is asserted.

1. Set the target pin number by writing FDCR[FDPINID[5:0]].
2. Set FDCR[FDBPEN], if the target pin is working as BP. Or set FDCR[FDBPEN] as 0, if the target pin is working as FP.
3. Select the sample clock frequency by setting FDCR[FDPRS[2:0]].
4. Set the sample window by writing to FDCR[FDSWW[2:0]].
5. Enable the detection by writing 1 to FDCR[FDEN].
6. Waiting until the FDSR[FDCF] bit is asserted (by polling or by interrupt).
7. Read the FDSR[FDCNT].
8. Write 1 to clear FSCR[FDCF].

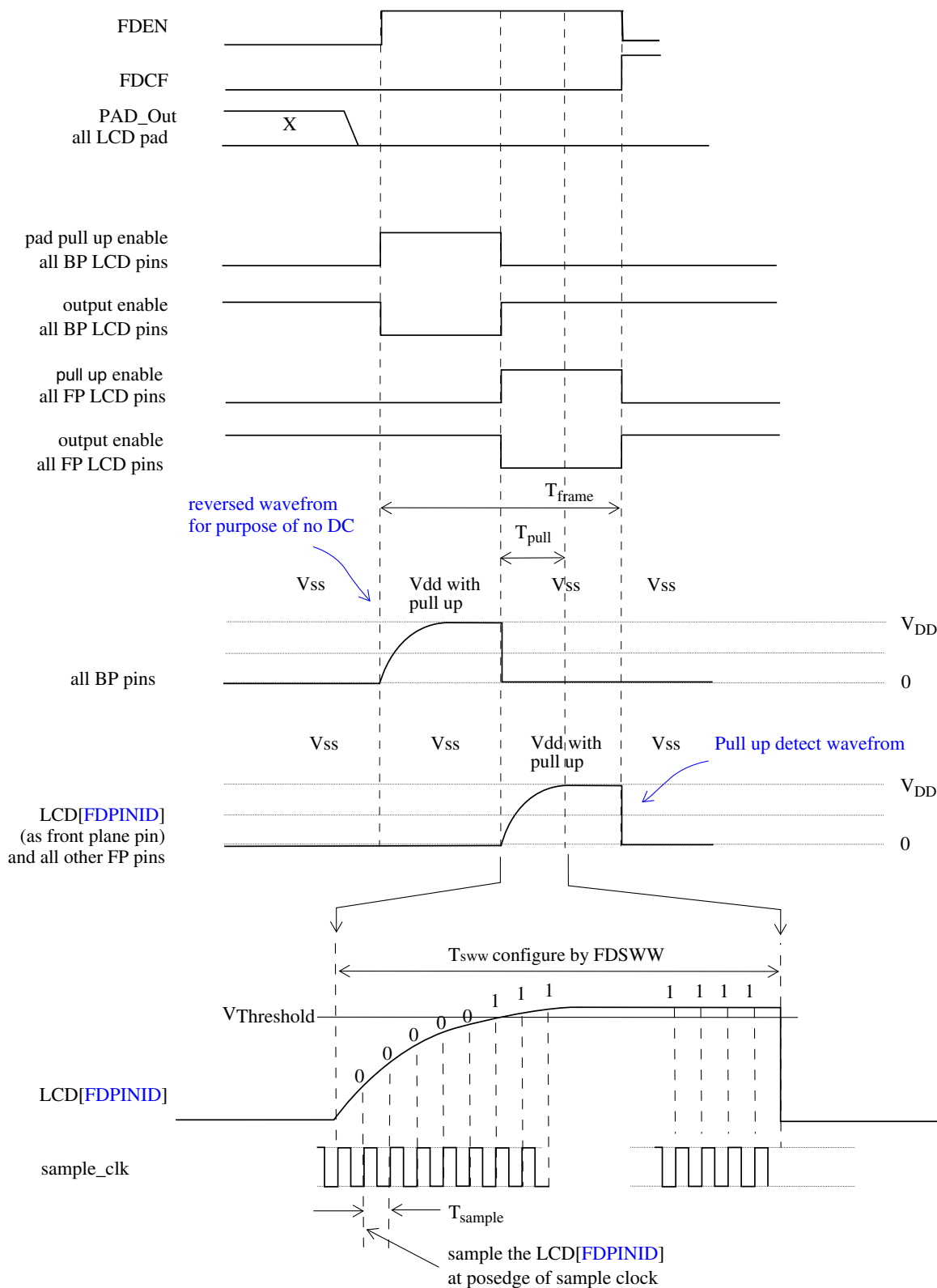

Figure 52-36. Pullup fault detection timing diagram, while FDBPEN is 0

functional description

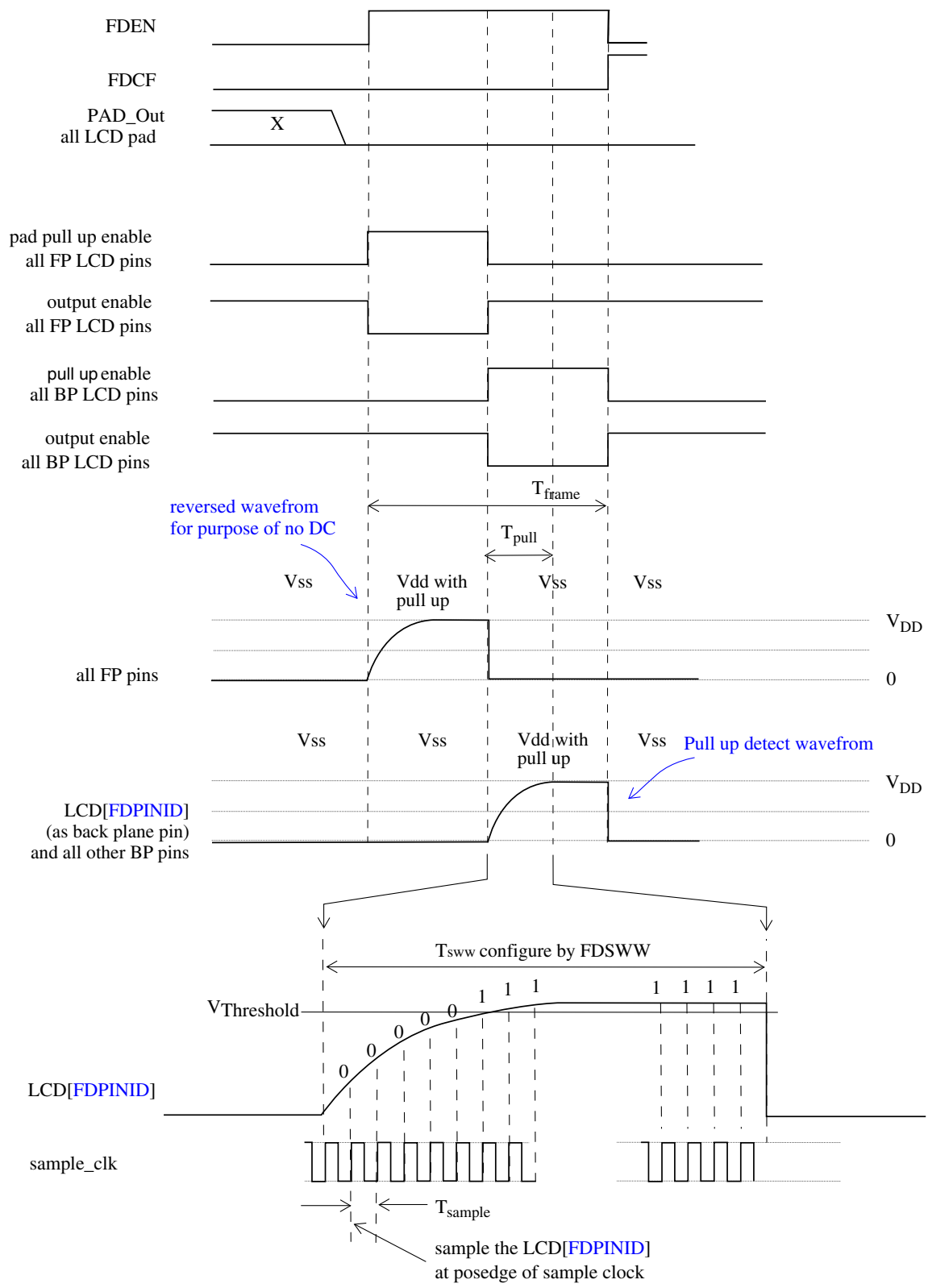

Figure 52-37. Pullup fault detection timing diagram, while FDBPEN is 1

Note

The voltage waveforms applied to the LCD electrodes must have no DC component. Therefore, a reversed pullup voltage waveform should be applied before the pullup detect waveform.

Fault detection occupies one frame and the pullup time is half-frame duration. You must ensure that the fault detection window set by the sample window width is less than half-frame duration.

52.5 Initialization section

This section provides a recommended initialization sequence for the LCD controller and also includes initialization examples for several LCD application scenarios.

52.5.1 Initialization sequence

The below list provides a recommended initialization sequence for the LCD controller.

You must write to all PEN, BPEN, and WFyTOx registers to initialize their values after a reset.

1. GCR
 - a. Configure LCD clock source (SOURCE bit).
 - b. Select 1.0 V or 1.67 V for 3 or 5 V glass (HREFSEL).
 - c. Enable regulated voltage (RVEN).
 - d. Trim the regulated voltage (RVTRIM).
 - e. Enable charge pump (CPSEL bit).
 - f. Configure LCD controller for doubler or tripler mode (HREFSEL bit).
 - g. Configure charge pump clock (LADJ[1:0]).
 - h. Configure LCD power supply (VSUPPLY[1:0]).
 - i. Configure LCD frame frequency interrupt (LCDIEN bit).
 - j. Configure LCD behavior in low power mode (LCDWAIT and LCDSTP bits).
 - k. Configure LCD duty cycle (DUTY[2:0]).

1. Select and configure LCD frame frequency (LCLK[2:0]).
2. AR
 - a. Configure display mode (ALT and BLANK bits).
 - b. Configure blink mode (BMODE).
 - c. Configure blink frequency (BRATE[2:0]).
3. PENn
 - a. Enable LCD controller pins (PEN[63:0] bits).
4. BPENn
 - a. Enable LCD pins to operate as an LCD backplane (BPEN[63:0]).
5. WfYTOx
 - a. Initialize WfYTOx registers with backplane configuration and an initial display screen.
6. GCR
 - a. Enable LCD controller (LCDEN bit).

52.5.2 Initialization Examples

This section provides initialization information for LCD configuration. Each example details the register and bit-field values required to achieve the appropriate LCD configuration for a given LCD application scenario. The table below lists each example and the setup requirements.

Table 52-41. LCD application scenario

Example	Operating Voltage, V _{DD}	LCD Clock Source	LCD Glass Operating Voltage	Required LCD Segments	LCD Frame Rate	Blinking Mode/ Rate	Behavior in Wait/Stop Modes	LCD Power Input
1	2.7 V	External 32.768 kHz	3 V	128	30 Hz	None	Wait: on Stop: on	Power via External Resistor Bias Network
2	3.3 V	Internal 39.063 kHz	5 V	100	50 Hz	Alternate 0.5 Hz	Wait: on Stop: off	Powered via internal connection from V _{DD} to V _{LL2}

These examples illustrate the flexibility of the LCD controller to be configured to meet a wide range of application requirements including:

- Clock inputs/sources
- LCD power supply
- LCD glass operating voltage
- LCD segment count
- Varied blink modes/frequencies
- LCD frame rate

52.5.2.1 Initialization example 1

Table 52-42. LCD setup requirements for example 1

Example	Operating voltage, V _{DD}	LCD clock source	LCD glass operating voltage	Required LCD segments	LCD frame rate	Blinking mode/rate	Behavior in Stop and Wait modes	LCD power input
1	2.7 V	External 32.768 kHz	3 V	128	30 Hz	None	Wait: on Stop: on	Power via External Resistor Bias Network

The table below lists the setup values required to initialize the LCD as specified by example 1:

Table 52-43. Initialization register values for example 1

Register	Bit or bit field	Binary value	Comment
GCR	CPSEL	0	Disable charge pump.
	LADJ[1:0]	XX	Adjust the resistor bias network for different LCD glass capacitance. or Configure LCD charge pump clock source.
	VSUPPLY[1:0]	11	When VSUPPLY[1:0] = 11 and CPSEL = 0, the LCD must be externally powered via V _{LL3} (see Table 52-38).
	LCDIEN	0	LCD frame interrupts disabled.
	LCDWAIT	1	LCD is "on" in Wait mode.
	LCDSTP	1	LCD is "on" in Stop mode.
	LCDEN	0	Initialization is done before initializing the LCD controller,
	SOURCE	0	Selects the external clock reference as the LCD clock input,
	LCLK[2:0]	101	For 1/8 duty cycle, select closest value to the desired 30 Hz LCD frame frequency (see Table 52-31),
	DUTY[2:0]	111	For 128 segments (8x16), select 1/8 duty cycle.
	RVEN	0	V _{I_{REG}} is not used for this configuration.
	RVTRIM[3:0]	XXXX	Trim value is determined by characterization.
AR	BLINK	0	No blinking.
	ALT	X	Alternate bit is configured during LCD operation.
	BLANK	X	Blank bit is configured during LCD operation.
	BMODE	X	N/A; Blink Blank = 0; Blink Alternate = 1
	BRATE[2:0]	XXX	N/A
PEN[3:0]	PEN0	11111111	Only 29 LCD pins need to be enabled. Note: Any of the 63 LCD pins can be used, this allows flexibility in the hardware design.
	PEN1	11111111	
	PEN2	11111111	
	PEN3	00000000	
BPEN[3:0]	BPEN0	11111111	Eight backplane pins needed. Note: Any LCD pin can be enabled to operate as a backplane.
	BPEN1	00000000	
	BPEN2	00000000	
	BPEN3	00000000	

Table continues on the next page...

Table 52-43. Initialization register values for example 1 (continued)

Register	Bit or bit field	Binary value	Comment
WFyTOx	WF0	00000001	Configure which phase the eight backplane pins are active in. This configuration sets LCD_P0 to be active in Phase A, LCD_P1 to be active in Phase B, and so on.
	WF1	00000010	
	WF2	00000100	This configuration sets LCD pins 0-7 to represent backplane 1-8. Note: Any backplane pin can be active in any phase.
	WF3	00001000	
	WF4	00010000	
	WF5	00100000	
	WF6	01000000	
	WF7	10000000	

52.5.2.2 Initialization example 2

Example 2 LCD setup requirements are reiterated in the table below:

Table 52-44. LCD setup requirements for example 2

Example	Operating voltage, V _{DD}	LCD clock source	LCD glass operating voltage	Required LCD segments	LCD frame rate	Blinking mode/rate	Behavior in Stop and Wait modes	LCD power input
2	5.5 V	Internal 39.063 kHz	3 V	100	50 Hz	Alternate 0.5 Hz	Wait: on Stop: off	Power via V _{DD}

The table below lists the required setup values required to initialize the LCD as specified by example 2:

Table 52-45. Initialization register values for example 2

Register	Bit or bit field	Binary value	Comment
GCR	CPSEL	1	Enable charge pump.
	LADJ[1:0]	00	Adjust the resistor bias network for different LCD glass capacitance. or Configure LCD charge pump clock source.
	VSUPPLY[1:0]	01	Generate V_{LL3} from V_{DD} (See Table 52-38).
	LCDIEN	0	LCD Frame Interrupts disabled.
	LCDWAIT	1	LCD is "on" in Wait mode.
	LCDSTP	0	LCD is "off" in Stop mode.
	LCDEN	0	Initialization is done before initializing the LCD controller.
	SOURCE	1	Selects the alternate-clock reference as the LCD clock input. This clock source is configured by the ICS TRIM bits to be 39.063 kHz.
	LCLK[2:0]	010	For 1/4 duty cycle, select closest value to the desired 50 Hz LCD frame frequency (Table 52-32).
	DUTY[2:0]	011	For 100 segments (4x25), select 1/4 duty cycle.
	RVEN	1	Enable VIREG so it can be used to supply the LCD.
	RVTRIM[3:0]	XXXX	Trim value is determined by characterization.
	AR	BLINK	1
ALT		X	Alternate bit is configured during LCD operation.
BLANK		X	Blank bit is configured during LCD operation.
BMODE		1	Blink Alternate = 1
BRATE[2:0]		100	Select 5 Hz blink frequency using Table 52-36 .
PEN[3:0]	PEN0	11111111	29 LCD pins need to be enabled.
	PEN1	11111111	
	PEN2	11111111	
	PEN3	00011111	
BPEN[3:0]	BPEN0	00001111	Four backplane pins needed. Note: Any LCD pin can be enabled to operate as a backplane.
	BPEN1	00000000	
	BPEN2	00000000	
	BPEN3	00000000	
WFyTOx	WF0	00000001	Configure which phase the four backplane pins are active in. This configuration sets LCD_P0 to be active in Phase A, LCD_P1 to be active in Phase B, and so on. This configuration sets LCD pins 0-3 to represent backplane 1-4. Note: Any backplane pin can be active in any of the phases.
	WF1	00000010	
	WF2	00000100	
	WF3	00001000	

52.5.2.3 Initialization example 3

Example 3 LCD setup requirements are reiterated in the table below:

Table 52-46. LCD setup requirements for example 3

Example	Operating voltage, V_{DD}	LCD clock source	LCD glass operating voltage	Required LCD segments	LCD frame rate	Blinking mode/rate	Behavior in Stop and Wait modes	LCD power input
3	5.0 V	External 32.768 kHz	5 V	168	30 Hz	Blank 2.0 Hz	Wait: off Stop: off	Power via V_{LL3}

The table below lists the required setup values required to initialize the LCD as specified by example 3:

Table 52-47. Initialization register values for example 3

Register	Bit or bit field	Binary value	Comment
GCR	CPSEL	1	Enable charge pump.
	LADJ[1:0]	00	Adjust the resistor bias network for different LCD glass capacitance. or Configure LCD charge pump clock source.
	VSUPPLY[1:0]	11	When VSUPPLY[1:0] = 11, the LCD can be powered via V_{LL3} (see Table 52-38).
	LCDIEN	0	LCD Frame Interrupts disabled.
	LCDWAIT	0	LCD is "off" in Wait mode.
	LCDSTP	0	LCD is "off" in Stop mode.
	LCDEN	0	Initialization is done before initializing the LCD controller.
	SOURCE	0	Selects LCD clock source (32.768 kHz crystal).
	LCLK[2:0]	101	For 1/8 duty cycle, select closest value to the desired 30 Hz LCD frame frequency (see Table 52-31).
	DUTY[2:0]	111	For 168 segments (8x21), select 1/8 duty cycle.
	RVEN	1	Enable VIREG so it can be used to supply the LCD.
	RVTRIM[3:0]	XXXX	Trim value is determined by characterization.
AR	BLINK	X	Blinking is turned on or off during LCD operation.
	ALT	X	Alternate bit is configured during LCD operation.
	BLANK	X	Blank bit is configured during LCD operation.
	BMODE	0	Blink to a blank mode.
	BRATE[2:0]	010	Select 2 Hz blink frequency using Table 52-36 .

Table continues on the next page...

Table 52-47. Initialization register values for example 3 (continued)

Register	Bit or bit field	Binary value	Comment
PEN[3:0]	PEN0	11111111	29 LCD pins need to be enabled.
	PEN1	11111111	
	PEN2	11111111	
	PEN3	00011111	
BPEN[3:0]	BPEN0	11111111	Eight backplane pins needed. Note: Any LCD pin can be enabled to operate as a backplane.
	BPEN1	00000000	
	BPEN2	00000000	
	BPEN3	00000000	
WFyTOx	WF0	00000001	Configure which phase the eight backplane pins are active in. This configuration sets LCD_P0 to be active in Phase A, LCD_P1 to be active in Phase B, and so on. This configuration sets LCD pins 0-7 to represent backplane 1-8. Note: Any backplane pin can be active in any phase.
	WF1	00000010	
	WF2	00000100	
	WF3	00001000	
	WF4	00010000	
	WF5	00100000	
	WF6	01000000	
	WF7	10000000	

52.6 Application information

The following figure is a programmer's model of the LCD controller. The programmer's model groups the LCD controller register bit and bit field into functional groups. The model is a high-level illustration of the LCD controller showing the module's functional hierarchy including initialization and runtime control.

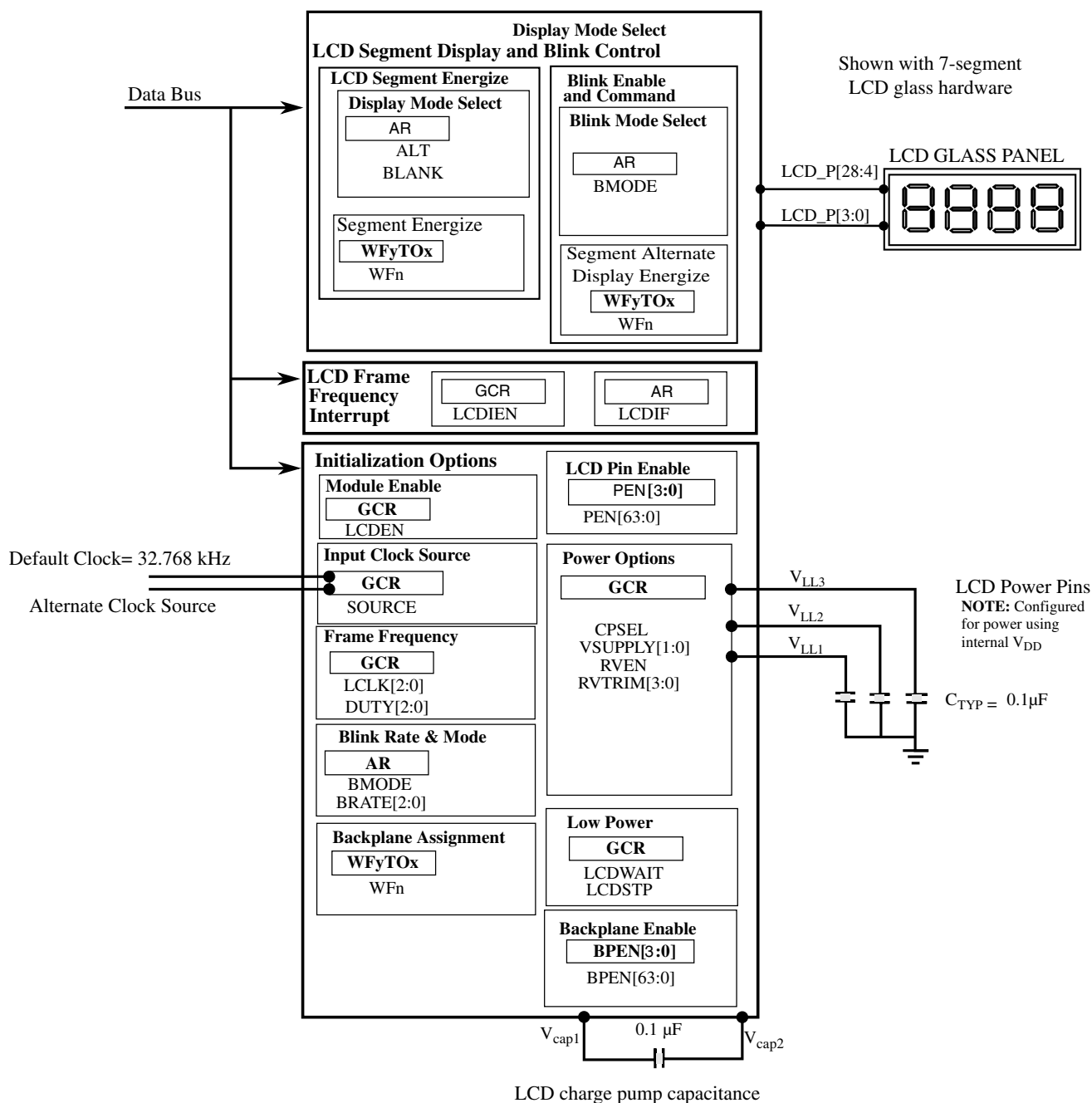
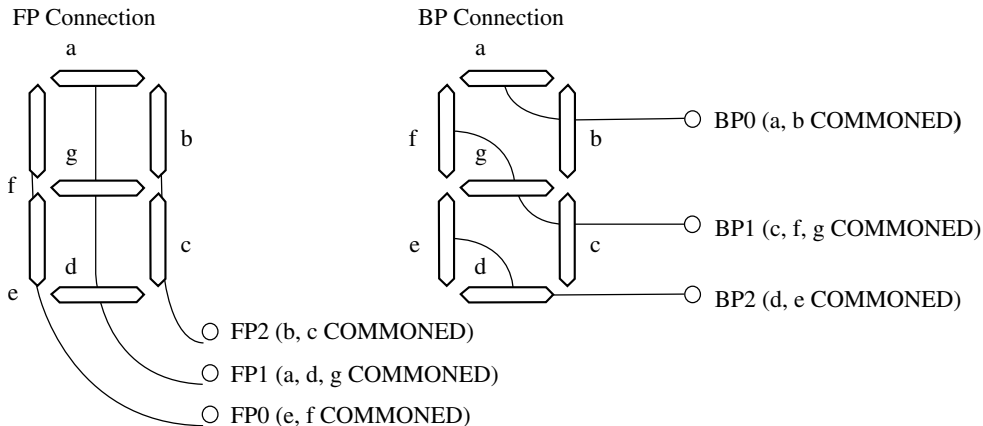

Figure 52-38. LCD programmer's model diagram

52.6.1 LCD seven segment example description

A description of the connection between the LCD controller and a seven segment LCD character is illustrated below to provide a basic example for a 1/3 duty cycle LCD implementation. The example uses three backplane pins (LCD_P3, LCD_P4 and

LCD_P5 and 3 frontplane pins (LCD_P0, LCD_P1, and LCD_P2) WFyTOx registers contents and output waveforms are also shown. Output waveforms are illustrated in the following two figures.



The above segment assignments are provided by the specification for the LCD glass for this example. For this LCD controller any of the LCD pins can be configured to be Frontplane 0-2 or Backplane 0-2. For this example, set LCD_P0 as FP0, LCD_P1 as FP1, and LCD_P2 as FP2. For this example, set LCD_P3 as BP0, LCD_P4 as BP1 and LCD_P5 as BP2.

Backplane assignment is done in the LCD waveform registers as shown below:

WF3	0	0	0	0	0	0	0	1
WF4	0	0	0	0	0	0	1	0
WF5	0	0	0	0	0	1	0	0

With the above conditions the segment assignment is shown below:

WF0	-	-	-	-	-	e	f	-
WF1	-	-	-	-	-	d	g	a
WF2	-	-	-	-	-	-	c	b

To display the character "4": WF0 = XXXXX01X, WF1 = XXXXX010, WF2 = XXXXXX11

WF0	X	X	X	X	X	0	1	X
WF1	X	X	X	X	X	0	1	0
WF2	X	X	X	X	X	X	1	1

X = don't care

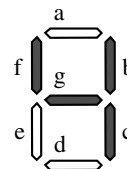

Figure 52-39. Waveform output from WFyTOx registers

52.6.1.1 LCD controller waveforms

DUTY = 1/3

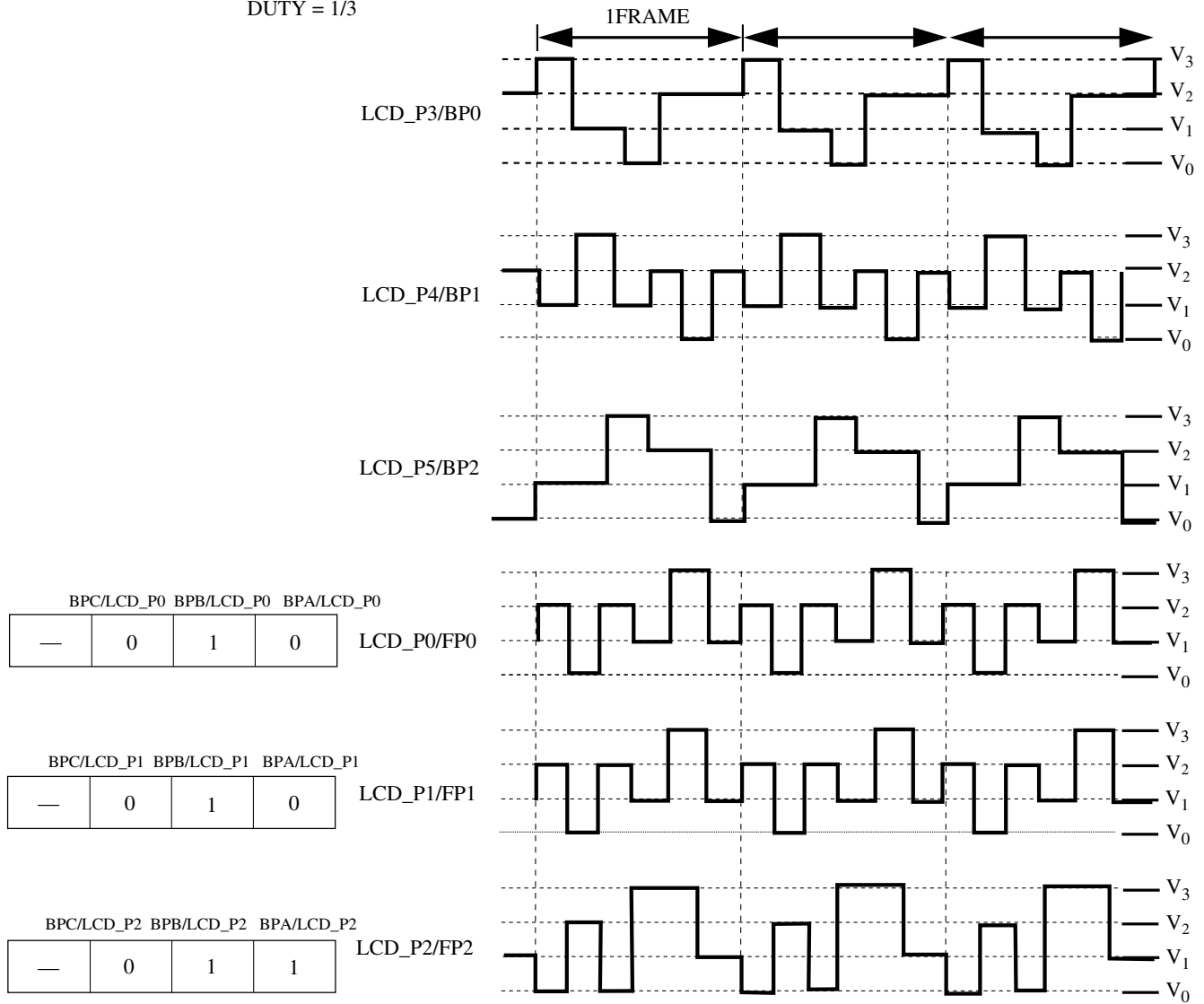

Figure 52-40. LCD waveforms

52.6.1.2 Segment on driving waveform

The voltage waveform across the "f" segment of the LCD (between LCD_P4/BP1 and LCD_P0/FP0) is illustrated in the following figure. As shown in the waveform, the voltage level reaches the value V_3 therefore, the segment will be on.

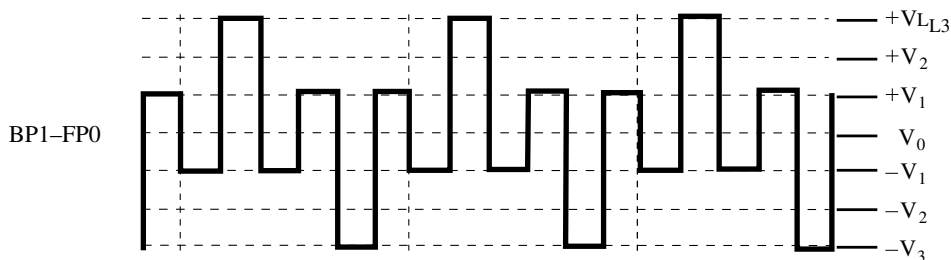

Figure 52-41. "f" segment voltage waveform

52.6.1.3 Segment off driving waveform

The voltage waveform across the "e" segment of the LCD (between LCD_P5/BP2 and LCD_P0/FP0) is illustrated in the following figure. As shown in the waveform, the voltage does not reach the voltage V_3 threshold therefore, the segment will be off.

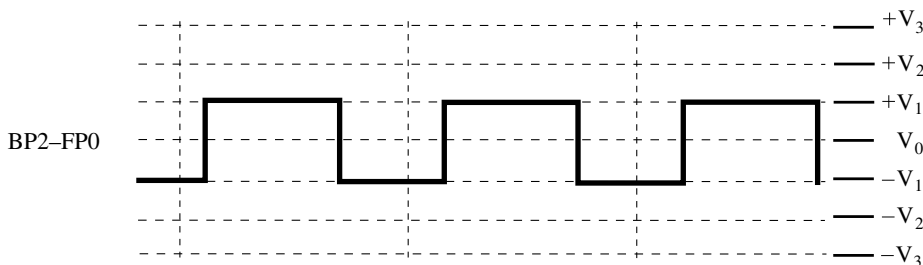

Figure 52-42. "e" segment voltage waveform

52.6.2 LCD contrast control

Contrast control for the LCD controller is achieved when the LCD power supply is adjusted above and below the LCD threshold voltage. The LCD threshold voltage is the nominal voltage required to energize the LCD segments. For 3 V LCD glass, the LCD threshold voltage is 3 V; while for 5 V LCD glass it is 5 V. By increasing the value of the LCD voltage, the energized segments on the LCD glass become more opaque. Decreasing the value of the LCD voltage makes the energized segments on the LCD glass become more transparent. The LCD power supply can be adjusted to facilitate contrast control by using external components like a variable resistor.

NOTE:
 Contrast control configuration
 when LCD is powered using
 internal V_{DD}
 V_{DD} is specified between 2.7 and
 5.5 V.

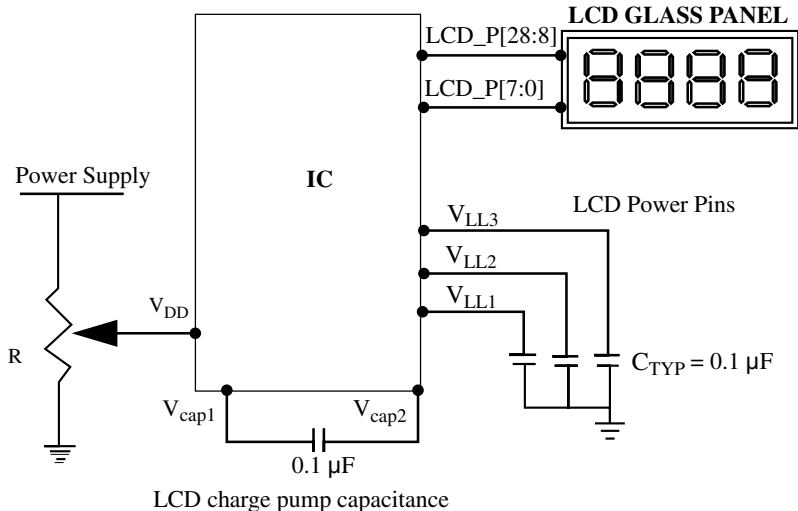

Figure 52-43. Power connections for contrast control



Chapter 53

JTAG Controller (JTAGC)

53.1 Introduction

NOTE

For the chip-specific implementation details of this module's instances see the chip configuration chapter.

The JTAGC block provides the means to test chip functionality and connectivity while remaining transparent to system logic when not in test mode. Testing is performed via a boundary scan technique, as defined in the IEEE 1149.1-2001 standard. All data input to and output from the JTAGC block is communicated in serial format.

53.1.1 Block diagram

The following is a block diagram of the JTAG Controller (JTAGC) block.

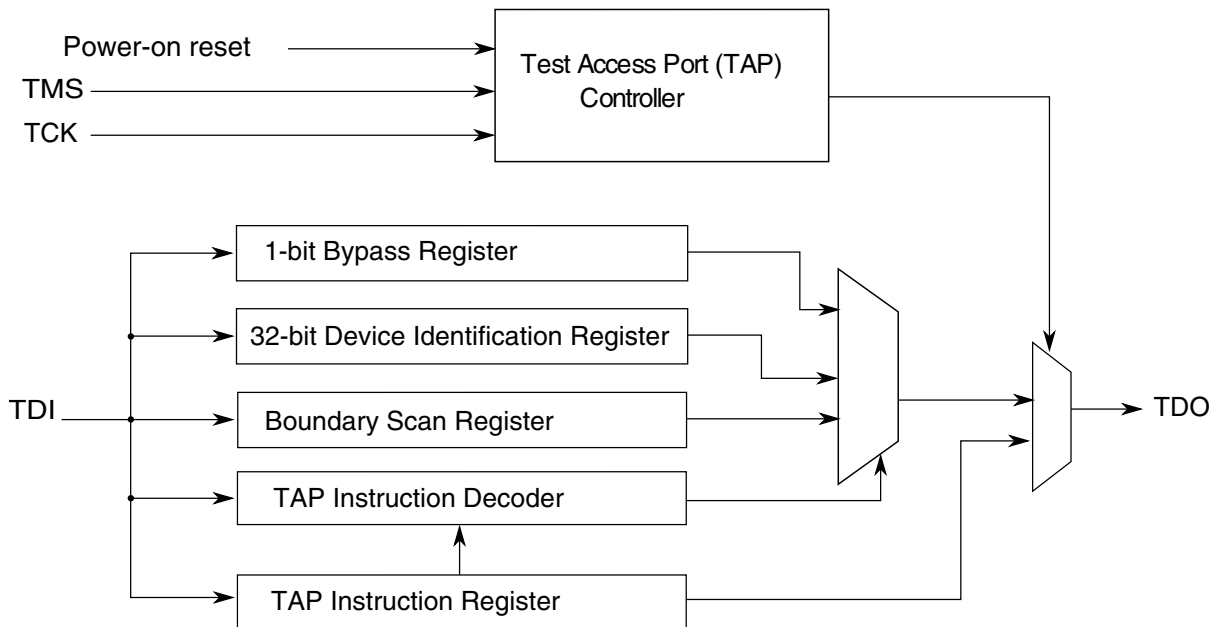

Figure 53-1. JTAG (IEEE 1149.1) block diagram

53.1.2 Features

The JTAGC block is compliant with the IEEE 1149.1-2001 standard and supports the following features:

- IEEE 1149.1-2001 Test Access Port (TAP) interface
 - 4 pins (TDI, TMS, TCK, and TDO)
- Instruction register that supports several IEEE 1149.1-2001 defined instructions as well as several public and private device-specific instructions. Refer to [Table 53-3](#) for a list of supported instructions.
- Data registers, bypass register, boundary scan register, and device identification register.
- TAP controller state machine that controls the operation of the data registers, instruction register and associated circuitry.

53.1.3 Modes of operation

The JTAGC block uses a power-on reset indication as its primary reset signals. Several IEEE 1149.1-2001 defined test modes are supported, as well as a bypass mode.

53.1.3.1 Reset

The JTAGC block is placed in reset when either power-on reset is asserted, or the TMS input is held high for enough consecutive rising edges of TCK to sequence the TAP controller state machine into the Test-Logic-Reset state. Holding TMS high for five consecutive rising edges of TCK guarantees entry into the Test-Logic-Reset state regardless of the current TAP controller state. Asserting power-on reset results in asynchronous entry into the reset state. While in reset, the following actions occur:

- The TAP controller is forced into the Test-Logic-Reset state, thereby disabling the test logic and allowing normal operation of the on-chip system logic to continue unhindered
- The instruction register is loaded with the IDCODE instruction

53.1.3.2 IEEE 1149.1-2001 defined test modes

The JTAGC block supports several IEEE 1149.1-2001 defined test modes. A test mode is selected by loading the appropriate instruction into the instruction register while the JTAGC is enabled. Supported test instructions include EXTEST, HIGHZ, CLAMP, SAMPLE and SAMPLE/PRELOAD. Each instruction defines the set of data register(s) that may operate and interact with the on-chip system logic while the instruction is current. Only one test data register path is enabled to shift data between TDI and TDO for each instruction.

The boundary scan register is enabled for serial access between TDI and TDO when the EXTEST, SAMPLE or SAMPLE/PRELOAD instructions are active. The single-bit bypass register shift stage is enabled for serial access between TDI and TDO when the BYPASS, HIGHZ, CLAMP or reserved instructions are active. The functionality of each test mode is explained in more detail in [JTAGC block instructions](#).

53.1.3.3 Bypass mode

When no test operation is required, the BYPASS instruction can be loaded to place the JTAGC block into bypass mode. While in bypass mode, the single-bit bypass shift register is used to provide a minimum-length serial path to shift data between TDI and TDO.

53.2 External signal description

The JTAGC consists of a set of signals that connect to off chip development tools and allow access to test support functions. The JTAGC signals are outlined in the following table and described in the following sections.

Table 53-1. JTAG signal properties

Name	I/O	Function	Reset State	Pull
TCK	Input	Test Clock	—	Down
TDI	Input	Test Data In	—	Up
TDO	Output	Test Data Out	High Z ¹	—
TMS	Input	Test Mode Select	—	Up

1. TDO output buffer enable is negated when the JTAGC is not in the Shift-IR or Shift-DR states. A weak pull may be implemented at the TDO pad for use when JTAGC is inactive.

53.2.1 TCK—Test clock input

Test Clock Input (TCK) is an input pin used to synchronize the test logic and control register access through the TAP.

53.2.2 TDI—Test data input

Test Data Input (TDI) is an input pin that receives serial test instructions and data. TDI is sampled on the rising edge of TCK.

53.2.3 TDO—Test data output

Test Data Output (TDO) is an output pin that transmits serial output for test instructions and data. TDO is three-stateable and is actively driven only in the Shift-IR and Shift-DR states of the TAP controller state machine, which is described in [TAP controller state machine](#).

53.2.4 TMS—Test mode select

Test Mode Select (TMS) is an input pin used to sequence the IEEE 1149.1-2001 test control state machine. TMS is sampled on the rising edge of TCK.

53.3 Register description

This section provides a detailed description of the JTAGC block registers accessible through the TAP interface, including data registers and the instruction register. Individual bit-level descriptions and reset states of each register are included. These registers are not memory-mapped and can only be accessed through the TAP.

53.3.1 Instruction register

The JTAGC block uses a 4-bit instruction register as shown in the following figure. The instruction register allows instructions to be loaded into the block to select the test to be performed or the test data register to be accessed or both. Instructions are shifted in through TDI while the TAP controller is in the Shift-IR state, and latched on the falling edge of TCK in the Update-IR state. The latched instruction value can only be changed in the Update-IR and Test-Logic-Reset TAP controller states. Synchronous entry into the Test-Logic-Reset state results in the IDCODE instruction being loaded on the falling edge of TCK. Asynchronous entry into the Test-Logic-Reset state results in asynchronous loading of the IDCODE instruction. During the Capture-IR TAP controller state, the instruction shift register is loaded with the value 0001b, making this value the register's read value when the TAP controller is sequenced into the Shift-IR state.

	3	2	1	0
R	0	0	0	1
W	Instruction Code			
Reset:	0	0	0	1

Figure 53-2. Instruction register

53.3.2 Bypass register

The bypass register is a single-bit shift register path selected for serial data transfer between TDI and TDO when the BYPASS, CLAMP, HIGHZ or reserve instructions are active. After entry into the Capture-DR state, the single-bit shift register is set to a logic 0. Therefore, the first bit shifted out after selecting the bypass register is always a logic 0.

53.3.3 Device identification register

The device identification (JTAG ID) register, shown in the following figure, allows the revision number, part number, manufacturer, and design center responsible for the design of the part to be determined through the TAP. The device identification register is selected for serial data transfer between TDI and TDO when the IDCODE instruction is active. Entry into the Capture-DR state while the device identification register is selected loads the IDCODE into the shift register to be shifted out on TDO in the Shift-DR state. No action occurs in the Update-DR state.

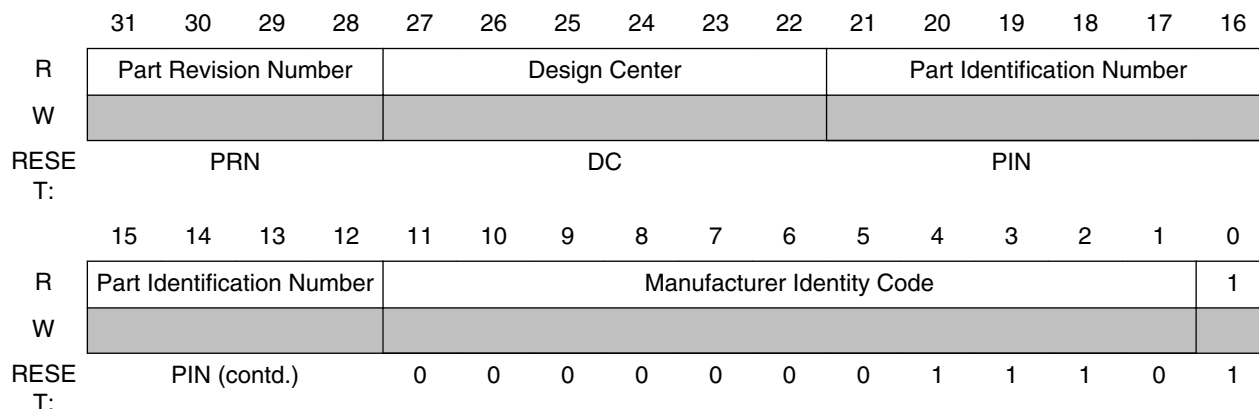

The following table describes the device identification register functions.

Table 53-2. Device identification register field descriptions

Field	Description
PRN	Part Revision Number. Contains the revision number of the part. Value is 0x0.
DC	Design Center. Indicates the design center. Value is 0x2C.
PIN	Part Identification Number. Contains the part number of the device. Value is TBD.
MIC	Manufacturer Identity Code. Contains the reduced Joint Electron Device Engineering Council (JEDEC) ID. Value is 0x00E .
IDCODE ID	IDCODE Register ID. Identifies this register as the device identification register and not the bypass register. Always set to 1.

53.3.4 Boundary scan register

The boundary scan register is connected between TDI and TDO when the EXTEST, SAMPLE or SAMPLE/PRELOAD instructions are active. It is used to capture input pin data, force fixed values on output pins, and select a logic value and direction for bidirectional pins. Each bit of the boundary scan register represents a separate boundary

scan register cell, as described in the IEEE 1149.1-2001 standard and discussed in [Boundary scan](#). The size of the boundary scan register and bit ordering is device-dependent and can be found in the device BSDL file.

53.4 Functional description

This section explains the JTAGC functional description.

53.4.1 JTAGC reset configuration

While in reset, the TAP controller is forced into the Test-Logic-Reset state, thus disabling the test logic and allowing normal operation of the on-chip system logic. In addition, the instruction register is loaded with the IDCODE instruction.

53.4.2 IEEE 1149.1-2001 (JTAG) Test Access Port

The JTAGC block uses the IEEE 1149.1-2001 TAP for accessing registers. This port can be shared with other TAP controllers on the MCU. Ownership of the port is determined by the value of the currently loaded instruction.

Data is shifted between TDI and TDO through the selected register starting with the least significant bit, as illustrated in the following figure. This applies for the instruction register, test data registers, and the bypass register.



Figure 53-3. Shifting data through a register

53.4.3 TAP controller state machine

The TAP controller is a synchronous state machine that interprets the sequence of logical values on the TMS pin. The following figure shows the machine's states. The value shown next to each state is the value of the TMS signal sampled on the rising edge of the TCK signal. As the following figure shows, holding TMS at logic 1 while clocking TCK through a sufficient number of rising edges also causes the state machine to enter the Test-Logic-Reset state.

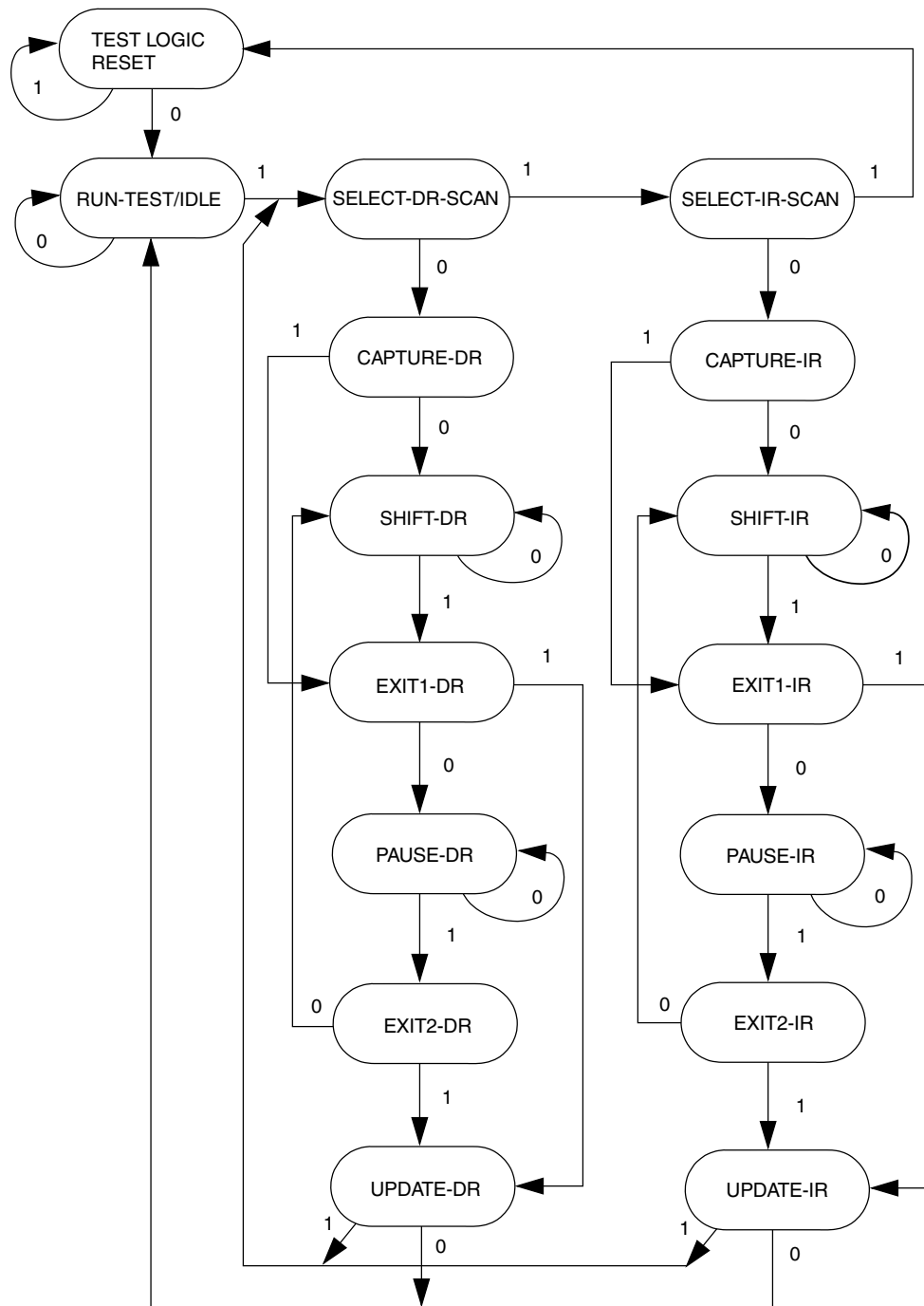

The value shown adjacent to each state transition in this figure represents the value of TMS at the time of a rising edge of TCK.

Figure 53-4. IEEE 1149.1-2001 TAP controller finite state machine

53.4.3.1 Enabling the TAP controller

The JTAGC TAP controller is enabled by setting the JTAGC enable to a logic 1 value.

53.4.3.2 Selecting an IEEE 1149.1-2001 register

Access to the JTAGC data registers is achieved by loading the instruction register with any of the JTAGC block instructions while the JTAGC is enabled. Instructions are shifted in via the Select-IR-Scan path and loaded in the Update-IR state. At this point, all data register access is performed via the Select-DR-Scan path.

The Select-DR-Scan path is used to read or write the register data by shifting in the data (LSB first) during the Shift-DR state. When reading a register, the register value is loaded into the IEEE 1149.1-2001 shifter during the Capture-DR state. When writing a register, the value is loaded from the IEEE 1149.1-2001 shifter to the register during the Update-DR state. When reading a register, there is no requirement to shift out the entire register contents. Shifting may be terminated once the required number of bits have been acquired.

53.4.4 JTAGC block instructions

The JTAGC block implements the IEEE 1149.1-2001 defined instructions listed in the following table. This section gives an overview of each instruction; refer to the IEEE 1149.1-2001 standard for more details. All undefined opcodes are reserved.

Table 53-3. 4-bit JTAG instructions

Instruction	Code[3:0]	Instruction Summary
IDCODE	0000	Selects device identification register for shift
EZPORT	0001	Enables the EZPORT function for the SoC
SAMPLE/PRELOAD	0010	Selects boundary scan register for shifting, sampling, and preloading without disturbing functional operation
SAMPLE	0011	Selects boundary scan register for shifting and sampling without disturbing functional operation
EXTEST	0100	Selects boundary scan register while applying preloaded values to output pins and asserting functional reset
Factory debug reserved	0101	Intended for factory debug only
Factory debug reserved	0110	Intended for factory debug only
Factory debug reserved	0111	Intended for factory debug only
ARM JTAG-DP Reserved	1000	This instruction goes the ARM JTAG-DP controller. See the ARM JTAG-DP documentation for more information.
HIGHZ	1001	Selects bypass register while three-stating all output pins and asserting functional reset
ARM JTAG-DP Reserved	1010	This instruction goes the ARM JTAG-DP controller. See the ARM JTAG-DP documentation for more information.

Table continues on the next page...

Table 53-3. 4-bit JTAG instructions (continued)

Instruction	Code[3:0]	Instruction Summary
ARM JTAG-DP Reserved	1011	This instruction goes the ARM JTAG-DP controller. See the ARM JTAG-DP documentation for more information.
CLAMP	1100	Selects bypass register while applying preloaded values to output pins and asserting functional reset
ARM JTAG-DP Reserved	1110	This instruction goes the ARM JTAG-DP controller. See the ARM JTAG-DP documentation for more information.
BYPASS	1111	Selects bypass register for data operations

53.4.4.1 IDCODE instruction

IDCODE selects the 32-bit device identification register as the shift path between TDI and TDO. This instruction allows interrogation of the MCU to determine its version number and other part identification data. IDCODE is the instruction placed into the instruction register when the JTAGC block is reset.

53.4.4.2 EZPORT instruction

The EZPORT instruction allows for the EZPORT module to program the on-chip flash from a simple 4-pin interface. The JTAGC forces the core into a reset state and forces the EZPORT mode select/chip select low. In this mode, the flash can be programmed through the JTAG test port pins, which are connected to the EZPORT module.

53.4.4.3 SAMPLE/PRELOAD instruction

The SAMPLE/PRELOAD instruction has two functions:

- The SAMPLE portion of the instruction obtains a sample of the system data and control signals present at the MCU input pins and just before the boundary scan register cells at the output pins. This sampling occurs on the rising edge of TCK in the Capture-DR state when the SAMPLE/PRELOAD instruction is active. The sampled data is viewed by shifting it through the boundary scan register to the TDO output during the Shift-DR state. Both the data capture and the shift operation are transparent to system operation.
- The PRELOAD portion of the instruction initializes the boundary scan register cells before selecting the EXTEST or CLAMP instructions to perform boundary scan tests. This is achieved by shifting in initialization data to the boundary scan register during the Shift-DR state. The initialization data is transferred to the parallel outputs

of the boundary scan register cells on the falling edge of TCK in the Update-DR state. The data is applied to the external output pins by the EXTEST or CLAMP instruction. System operation is not affected.

53.4.4.4 SAMPLE instruction

The SAMPLE instruction obtains a sample of the system data and control signals present at the MCU input pins and just before the boundary scan register cells at the output pins. This sampling occurs on the rising edge of TCK in the Capture-DR state when the SAMPLE instruction is active. The sampled data is viewed by shifting it through the boundary scan register to the TDO output during the Shift-DR state. There is no defined action in the Update-DR state. Both the data capture and the shift operation are transparent to system operation.

53.4.4.5 EXTEST External test instruction

EXTEST selects the boundary scan register as the shift path between TDI and TDO. It allows testing of off-chip circuitry and board-level interconnections by driving preloaded data contained in the boundary scan register onto the system output pins. Typically, the preloaded data is loaded into the boundary scan register using the SAMPLE/PRELOAD instruction before the selection of EXTEST. EXTEST asserts the internal system reset for the MCU to force a predictable internal state while performing external boundary scan operations.

53.4.4.6 HIGHZ instruction

HIGHZ selects the bypass register as the shift path between TDI and TDO. While HIGHZ is active all output drivers are placed in an inactive drive state (e.g., high impedance). HIGHZ also asserts the internal system reset for the MCU to force a predictable internal state.

53.4.4.7 CLAMP instruction

CLAMP allows the state of signals driven from MCU pins to be determined from the boundary scan register while the bypass register is selected as the serial path between TDI and TDO. CLAMP enhances test efficiency by reducing the overall shift path to a

single bit (the bypass register) while conducting an EXTEST type of instruction through the boundary scan register. CLAMP also asserts the internal system reset for the MCU to force a predictable internal state.

53.4.4.8 BYPASS instruction

BYPASS selects the bypass register, creating a single-bit shift register path between TDI and TDO. BYPASS enhances test efficiency by reducing the overall shift path when no test operation of the MCU is required. This allows more rapid movement of test data to and from other components on a board that are required to perform test functions. While the BYPASS instruction is active the system logic operates normally.

53.4.5 Boundary scan

The boundary scan technique allows signals at component boundaries to be controlled and observed through the shift-register stage associated with each pad. Each stage is part of a larger boundary scan register cell, and cells for each pad are interconnected serially to form a shift-register chain around the border of the design. The boundary scan register consists of this shift-register chain, and is connected between TDI and TDO when the EXTEST, SAMPLE, or SAMPLE/PRELOAD instructions are loaded. The shift-register chain contains a serial input and serial output, as well as clock and control signals.

53.5 Initialization/Application information

The test logic is a static logic design, and TCK can be stopped in either a high or low state without loss of data. However, the system clock is not synchronized to TCK internally. Any mixed operation using both the test logic and the system functional logic requires external synchronization.

To initialize the JTAGC block and enable access to registers, the following sequence is required:

1. Place the JTAGC in reset through TAP controller state machine transitions controlled by TMS
2. Load the appropriate instruction for the test or action to be performed

Appendix A

Release Notes for Revision 6

A.1 General changes throughout document

- No substantial content changes

A.2 About This Document chapter changes

- No substantial content changes

A.3 Introduction chapter changes

- Updated 'Kinetis MCU portfolio' diagram for K6x family.

A.4 Chip Configuration chapter changes

- Clarified 'PDB Module Interconnections' section.
- In 'UART interrupts' section, updated LON and ISO7816 interrupt sources.
- Clarified 'I2S/SAI clock generation' section.
- Added note to 'VREF Overview' section.
- Added notes to USB controller and USB voltage regulator configurations.
- Clarified the "Wake-up Sources" section within the "Low-Leakage Wake-up Unit (LLWU) Configuration" section. Renamed the "LLWU inputs" table to "Wakeup sources for LLWU inputs", removed the multiplexed signals and provided the pin name only. Added a reference to the signal multiplexing table for the individual signal options.
- In ADCx Channel Assignment, updated AD27 and AD29 input signal description.
- Clarified ADC and PGA Reference Options section.
- In LPTMR pulse counter input options section, clarified LPTMR_CSR[TPS]=11 chip input.
- Added notes to VREF Overview and DAC External Trigger Input Connections sections.
- Updated ADC and PGA Reference Options section.

A.5 Memory Map chapter changes

- Added Alternate non-volatile IRC user trim description topic.

A.6 Clock Distribution chapter changes

- Added 'SAI clock generation' diagram.
- Updated Clock Diagram for standard XTAL, EXTAL, and MCG clock names.
- In Device Clock Summary table, updated bus clock, external reference clock, USB FS clock, and TRACE clock.
- Updated Clocking diagram for IRC clock and updated MCGFFCLK definition.
- Added note to Debug trace clock section.
- In Clock Summary table, added RTC_CLKOUT clock.
- Updated Debug trace clock diagram.

A.7 Reset and Boot chapter changes

- In System resets section, updated associated input pins for JTAG.

A.8 Power Management chapter changes

- In 'Module Operation in Low Power Modes' section, changed LPT to LPTMR.
- In 'Entering and exiting power modes' section, updated wake-up flow from VLLSx.

A.9 Security chapter changes

- No substantial content changes

A.10 Debug chapter changes

- Updated the section "Debug Resets".

A.11 Signal Multiplexing and Signal Descriptions chapter changes

<ul style="list-style-type: none"> Updated pinout diagrams and tables
<ul style="list-style-type: none"> In 'Port control and interrupt module features' section, updated digital filter clock cycles from 1 to 32. Updated CMPx_IN signals to 5:0.
<ul style="list-style-type: none"> In 'System Signal Descriptions' table, modified RESET_b pin to I/O.
<ul style="list-style-type: none"> For the "Signal Multiplexing and Pin Assignments" table, added the LLWU inputs to the appropriate pin names.
<ul style="list-style-type: none">

A.12 PORT changes

<ul style="list-style-type: none"> No substantial content changes
--

A.13 SIM changes

<ul style="list-style-type: none"> Updated ADCxTRGSEL, PFSIZE, and EESIZE field descriptions.
--

A.14 Mode Controller changes

<ul style="list-style-type: none"> In Modes of Operation section, updated VLPR mode description in Power modes table. Clarified Very Low Power Run (VLPR) Mode section.

A.15 PMC changes

<ul style="list-style-type: none"> No substantial content changes
--

A.16 LLWU changes

<ul style="list-style-type: none"> No substantial content changes
--

A.17 MCM changes

<ul style="list-style-type: none"> No substantial content changes
--

A.18 Crossbar switch chapter changes

- No substantial content changes

A.19 MPU changes

- No substantial content changes

A.20 AIPS-Lite changes

- No substantial content changes

A.21 DMAMUX changes

- No substantial content changes

A.22 DMA changes

- No substantial content changes

A.23 EWM changes

- No substantial content changes

A.24 WDOG changes

Clarification added for no reset due to unlock sequence when ALLOW_UPDATE is cleared in Section "Unlocking and Updating the Watchdog".

A.25 MCG changes

- Updated CME, VDIV, PRDIV, PLLCLKEN bit field descriptions

Support of PLL loss of lock resets

A.26 OSC changes

- No substantial content changes

A.27 RTC Oscillator changes

- No substantial content changes

A.28 FMC changes

- Terminology update: changed "Directory" to "Tag" in the names of tag cache registers.

A.29 FTFL changes

- Erase All pin executes even if swap system has been initialized
- Clarify that certain erase commands allowed in UPDATE or UPDATE-ERASED swap states
- Swap system initializes to UPDATE-ERASED state
- Read Resource command accesses program flash 1 IFR using flash address [17]
- Swap indicator address not implicitly protected during Erase All Blocks command
- Erase All Blocks command erases program flash 1 IFR to uninitialized the swap system
- Modify swap command error handling
- Add sector size to feature list
- Correct address range for reserved field in program flash IFR
- Add protection check to list of command processing steps
- Remove references to NVM Normal and Special modes related to command protection checks

A.30 EzPort changes

- No substantial content changes

A.31 CRC changes

No substantial content changes

A.32 ADC changes

- Removed CLPD from generating gain calibration values procedure.
- Updated Pseudo-code example section for CFG1 and SC2 register bits.
- Removed band gap voltages, BGH and BGL.

A.33 CMP changes

- Updated CMPx_CR1[PMODE] field description.

A.34 DAC changes

- Updated DACx_C0[LPEN] field description.

A.35 VREF changes

- No substantial content changes

A.36 PDB changes

Added Debug mode and updated PDBEN encodings.

A.37 FTM changes

- No substantial content changes

A.38 PIT changes

- No substantial content changes

A.39 LPTMR changes

- Added note in LPTMR clocking section.

A.40 CMT changes

- No substantial content changes

A.41 RTC changes

Updated RTC_CR[14] bit field access.

Updated Time Alarm section with IER[TAIE].

A.42 USB changes

- No substantial content changes

A.43 USBDCD changes

- No substantial content changes

A.44 USB VREG changes

- No substantial content changes

A.45 FlexCAN changes

- No substantial content changes

A.46 DSPI chapter changes

- In 'Transmit FIFO Fill Interrupt or DMA Request' section, added note on using TFFF flag.

I2C changes

- Added links to corresponding functional description in the Delay fields in CTAR register.
- Renamed DSICR to DSICR0.
- Updated EOQ interrupt request description.
- Added SPITCF and DSITCF interrupt request descriptions and updated corresponding bit fields in SR register.
- Updated DIS_TXF and DIS_RXF bit field descriptions in MCR register.
- Updated 'Sample MSC downstream transmission using ITSB mode' diagram.

A.47 I2C changes

- In the "Address Matching Wakeup" section, expanded the note to clarify the feature's purpose.

A.48 UART changes

- Changed TWFIFO[TXWATER] in RDRF register to RWFIFO[RXWATER].

A.49 SDHC changes

- Removed the feature of "Support voltage selection by configuring vendor specific register bit"

A.50 I2S changes

- Updated 1111 encoding for TFWM0 and TFWM1 bit fields.

A.51 GPIO changes

- No substantial content changes

A.52 TSI changes

- No substantial content changes

A.53 SLCD changes

- No substantial content changes

A.54 JTAG Controller changes

- No substantial content changes

How to Reach Us:

Home Page:

www.freescale.com

Web Support:

<http://www.freescale.com/support>

USA/Europe or Locations Not Listed:

Freescale Semiconductor
 Technical Information Center, EL516
 2100 East Elliot Road
 Tempe, Arizona 85284
 +1-800-521-6274 or +1-480-768-2130
www.freescale.com/support

Europe, Middle East, and Africa:

Freescale Halbleiter Deutschland GmbH
 Technical Information Center
 Schatzbogen 7
 81829 Muenchen, Germany
 +44 1296 380 456 (English)
 +46 8 52200080 (English)
 +49 89 92103 559 (German)
 +33 1 69 35 48 48 (French)
www.freescale.com/support

Japan:

Freescale Semiconductor Japan Ltd.
 Headquarters
 ARCO Tower 15F
 1-8-1, Shimo-Meguro, Meguro-ku,
 Tokyo 153-0064
 Japan
 0120 191014 or +81 3 5437 9125
support.japan@freescale.com

Asia/Pacific:

Freescale Semiconductor China Ltd.
 Exchange Building 23F
 No. 118 Jianguo Road
 Chaoyang District
 Beijing 100022
 China
 +86 10 5879 8000
support.asia@freescale.com

For Literature Requests Only:

Freescale Semiconductor Literature Distribution Center
 1-800-441-2447 or +1-303-675-2140
 Fax: +1-303-675-2150
LDCForFreescaleSemiconductor@hibbertgroup.com

Information in this document is provided solely to enable system and software implementers to use Freescale Semiconductors products. There are no express or implied copyright licenses granted hereunder to design or fabricate any integrated circuits or integrated circuits based on the information in this document.

Freescale Semiconductor reserves the right to make changes without further notice to any products herein. Freescale Semiconductor makes no warranty, representation, or guarantee regarding the suitability of its products for any particular purpose, nor does Freescale Semiconductor assume any liability arising out of the application or use of any product or circuit, and specifically disclaims any liability, including without limitation consequential or incidental damages. "Typical" parameters that may be provided in Freescale Semiconductor data sheets and/or specifications can and do vary in different applications and actual performance may vary over time. All operating parameters, including "Typicals", must be validated for each customer application by customer's technical experts. Freescale Semiconductor does not convey any license under its patent rights nor the rights of others. Freescale Semiconductor products are not designed, intended, or authorized for use as components in systems intended for surgical implant into the body, or other applications intended to support or sustain life, or for any other application in which failure of the Freescale Semiconductor product could create a situation where personal injury or death may occur. Should Buyer purchase or use Freescale Semiconductor products for any such unintended or unauthorized application, Buyer shall indemnify Freescale Semiconductor and its officers, employees, subsidiaries, affiliates, and distributors harmless against all claims, costs, damages, and expenses, and reasonable attorney fees arising out of, directly or indirectly, any claim of personal injury or death associated with such unintended or unauthorized use, even if such claims alleges that Freescale Semiconductor was negligent regarding the design or manufacture of the part.

RoHS-compliant and/or Pb-free versions of Freescale products have the functionality and electrical characteristics as their non-RoHS-compliant and/or non-Pb-free counterparts. For further information, see <http://www.freescale.com> or contact your Freescale sales representative.

For information on Freescale's Environmental Products program, go to <http://www.freescale.com/epp>.

Freescale™ and the Freescale logo are trademarks of Freescale Semiconductor, Inc. All other product or service names are the property of their respective owners.

© 2011–2012 Freescale Semiconductor, Inc.

